



Power Clear® 518 Snowthrower Souffleuse à neige Power Clear® 518

Quick Start Guide/Guide de Démarrage Rapide

*

<p align="center">Register your product. Enregistrer votre produit.</p>	<p align="center">▲ WARNING</p> <p align="center">CALIFORNIA Proposition 65 Warning</p> <p>The engine exhaust from this product contains chemicals known to the State of California to cause cancer, birth defects, or other reproductive harm.</p> <p>Use of this product may cause exposure to chemicals known to the State of California to cause cancer, birth defects, or other reproductive harm.</p>
--	--

For the *Operator's Manual*, the complete warranty details, or to register your product, use the QR code, or visit www.Toro.com.
 Pour vous procurer le *Manuel de l'utilisateur*, des détails complets sur la garantie ou pour enregistrer votre produit, utilisez le code QR ou rendez-vous sur www.Toro.com.

<p>Read the <i>Operator's Manual</i>.</p> <p>Lisez le <i>Manuel de l'utilisateur</i>.</p>	<p>Cutting/dismemberment hazards of hand or foot, impeller and auger.</p> <p>Risque de coupure/mutilation des mains et des pieds par la turbine et la vis sans fin</p>	<p>Do not place your hand in the chute; shut off the engine before leaving the operator's position and use a tool to clear the chute.</p> <p>Ne placez pas la main dans la goulotte ; coupez le moteur avant de quitter la position d'utilisation et dégagez la goulotte avec un outil.</p>	<p>Remove the ignition key and read the instructions before servicing or performing maintenance.</p> <p>Retirez la clé de contact et lisez les instructions avant de procéder à l'entretien ou à des révisions.</p>	<p>Fuel spill hazard—do not tip the machine backward.</p> <p>Risque de déversement de carburant – n'inclinez pas la machine en arrière.</p>
<p>Thrown object hazard</p> <p>Risque de projections d'objet</p>	<p>Keep bystanders away.</p> <p>N'autorisez personne à s'approcher.</p>	<p>Shut off the engine and wait for the auger to stop before leaving the machine.</p> <p>Coupez le moteur et attendez l'arrêt complet de la vis sans fin avant de quitter la machine.</p>	<p>Stay away from moving parts; keep all guards and shields in place.</p> <p>Ne vous approchez pas des pièces mobiles, et laissez toutes les protections et tous les capots en place.</p>	

You may also mail us a written request for a printed copy of the product warranty.
 Vous pouvez également nous envoyer une demande écrite pour obtenir une copie imprimée de la garantie du produit.

1

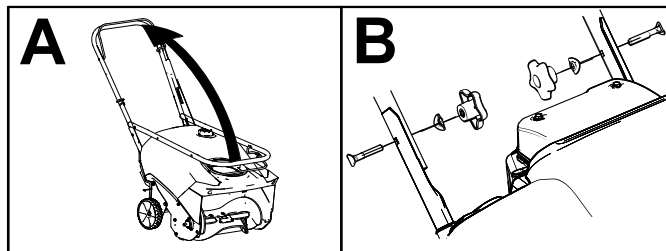
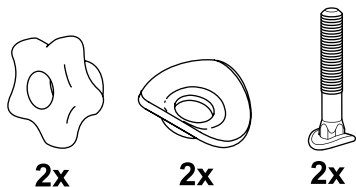

g385513



2

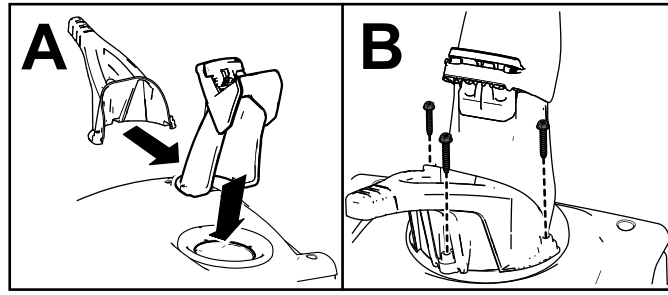
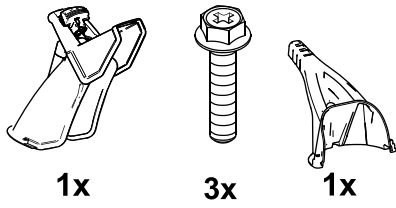

g385514

3

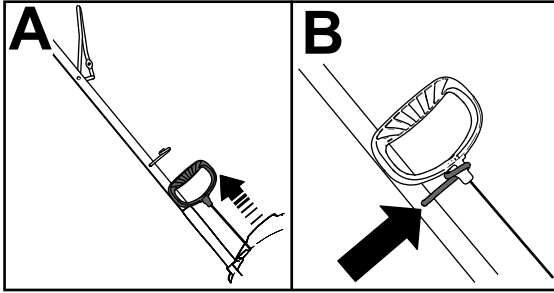

g253609

4

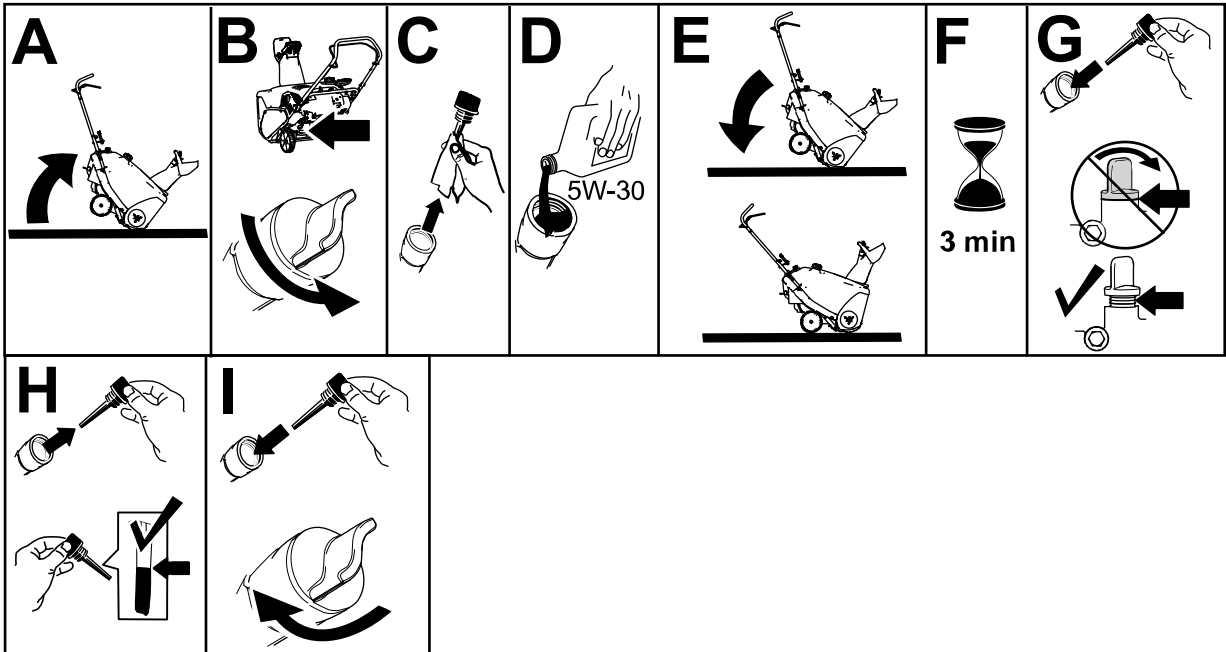

g253610

5

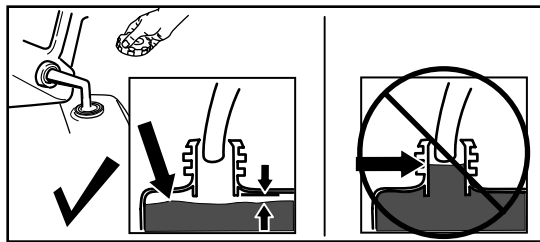

g252397

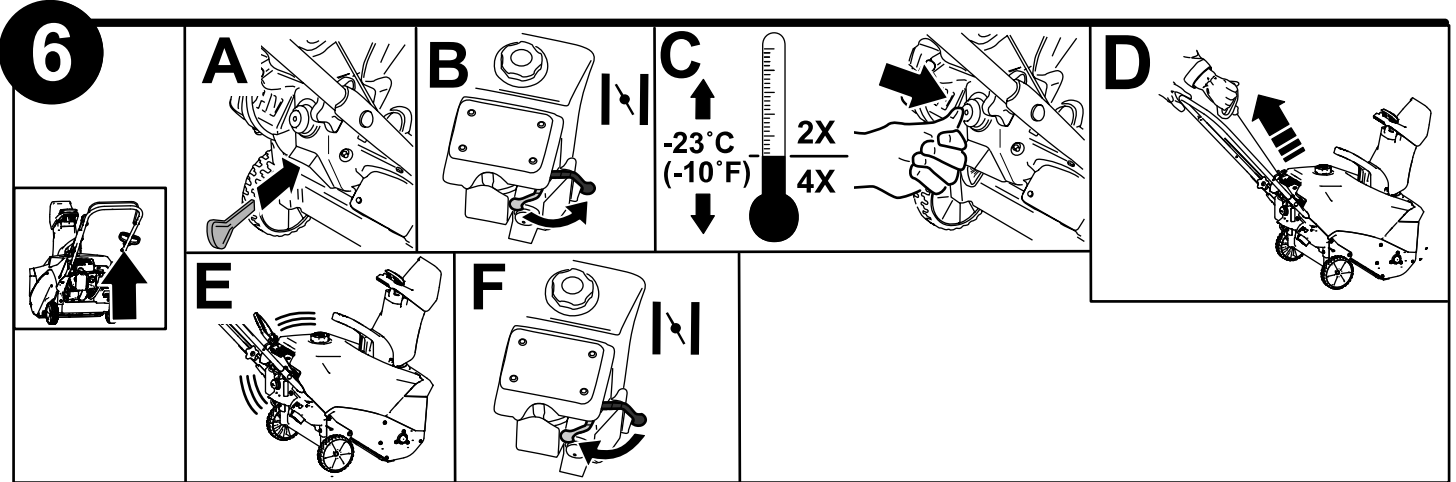
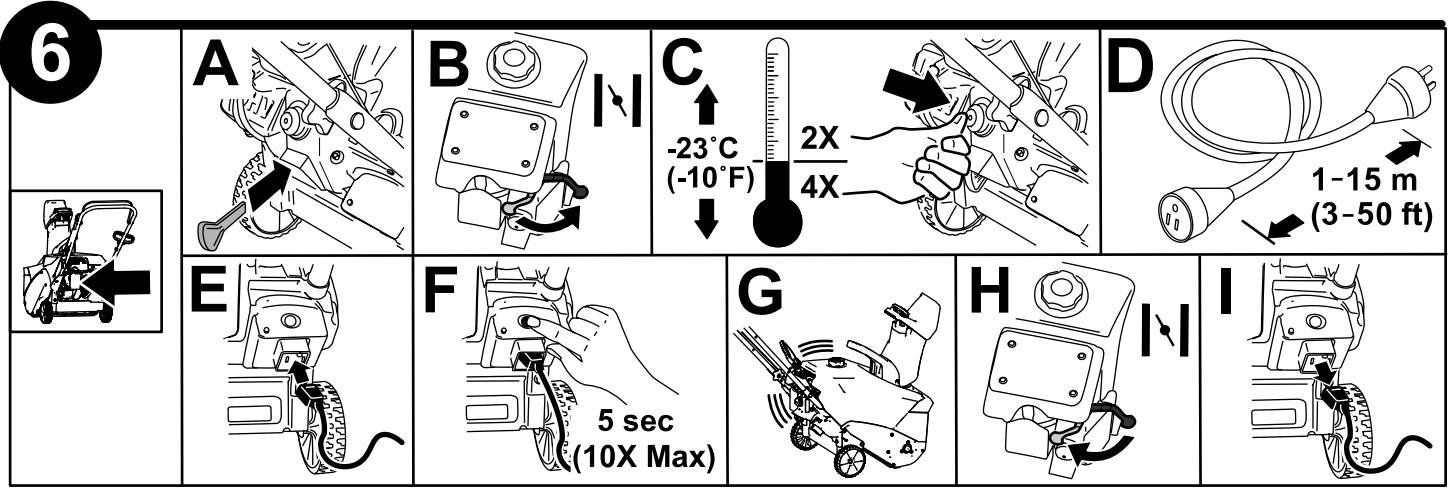

g385515

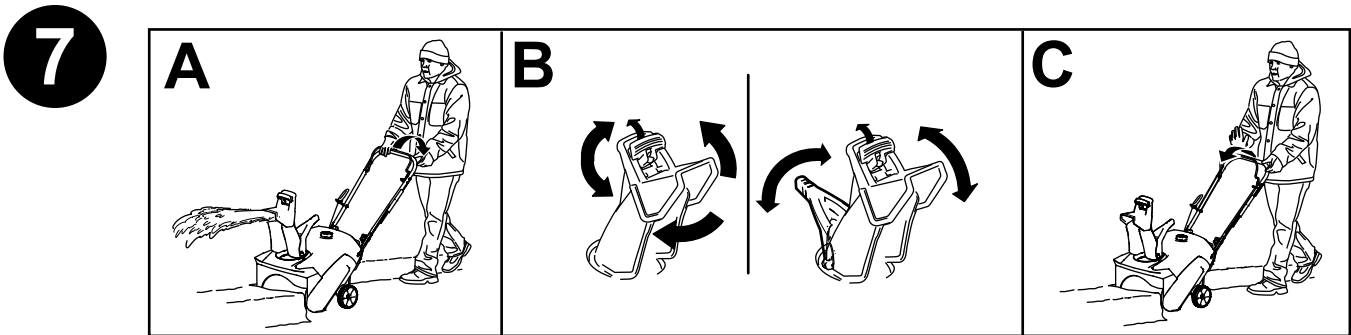

g385516

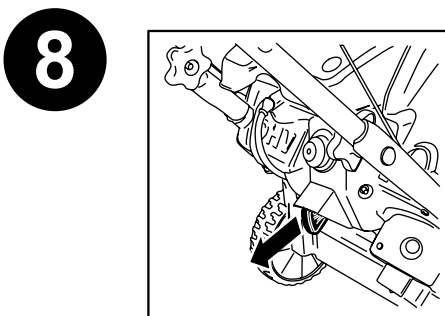

g253612

