



**Count on it.**

**Parts Catalog**

**Flex-Force Power System™**  
**60V Stick Edger**

Model No. 51833—Serial No. 321000001 and Up



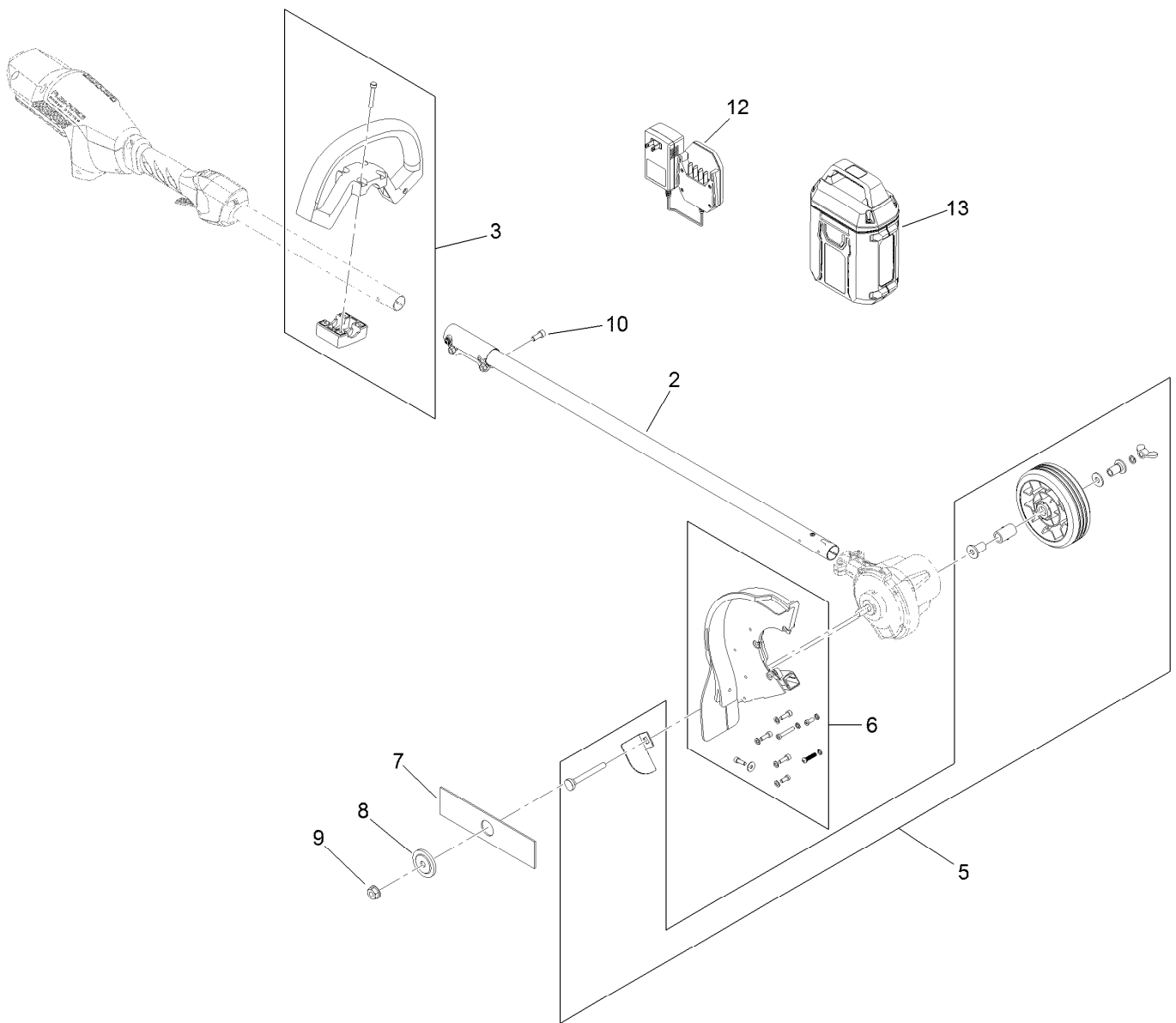

## Cordless 60V Stick Edger Assembly

<i>Ref.</i>	<i>Part Number</i>	<i>Qty.</i>	<i>Description</i>
2	139-5381	1	Shaft ASM
3	139-8255	1	Handle-Trimmer
5	139-5383	1	Wheel ASM
6	139-5384	1	Guard ASM
7	139-5385	1	Blade
8	139-5386	1	Washer
9	139-5387	1	Nut
10	139-5388	1	Screw-Rod
12	88610	1	Charger-Battery, 60V 1 Amp
13	88620	1	Battery-60V 2.0Ah

# Attachments and Accessories

## For 51833 Flex-Force Power System 60V Stick Edger

<b>Product Name</b>	<b>Model/Part</b>
60V Battery Charger 1 AMP .....	88610
60V Battery Charger 2 AMP .....	88602
60V Rapid Battery Charger 5.4 AMP .....	88605
60V 2.0 AH Battery .....	88620
60V LI-ION Battery 2.5 AH.....	88625
60V LI-ION, Battery 4.0 AH .....	88640
60V LI-ION Battery 5.0 AH.....	88650
60V LI-ION Battery 6.0 AH.....	88660
60V LI-ION Battery 7.5 AH.....	88675



**Count on it.**