



**Dingo<sup>®</sup> 420 TX**  
**Compact Utility Loader**  
Model No. 22306—220000001 and Up

## Parts Catalog

### Ordering Replacement Parts

To order replacement parts, please supply: the part number, the quantity, and the description of each part desired.

### Understanding Reference Numbers

Each identified part in an illustration has a reference number. The reference number for a part also appears in the parts list, along with other information about the part.

This catalog uses two special reference number formats, one to indicate parts in a service assembly and another to indicate the quantity of a given part in an illustration.

### Service Assembly Reference Numbers

Parts in service assemblies have reference numbers in the form **a:b**. The **a** represents the reference number of the entire service assembly and the **b** represents a sequential number unique to each part within the service assembly.

For example, a wheel assembly might be identified by reference number **6**, the tire by **6:1**, the valve by **6:2**, and the wheel by **6:3**. When you order the assembly identified by reference number **6**, you receive all parts identified by reference numbers **6:1**, **6:2**, and **6:3**. However, you may also order any part individually.

Reference numbers of this type appear in illustrations and in part lists.

### Reference Numbers Indicating Quantity

In an illustration, if a reference number indicates more than one part, the reference number has the form **nX y**. The **n** represents the quantity of the part, the **X** is the multiplication symbol, and the **y** represents the reference number.

For example, in an illustration, the reference number **2X 37** means that two of the parts identified by reference number **37** are indicated.

## Contents

Description	Page	Description	Page
Main Frame and Fuel Tank Assembly .....	3	Quick Attach Assembly .....	27
Track and Traction Assembly .....	4	Electrical Assembly .....	28
Brake Assembly .....	5	Grill Assembly .....	29
Loader Tower and Drive Assembly .....	6	Hydraulic Cooler Assembly .....	30
Traction Hydraulic Assembly .....	7	Hood Assembly .....	31
Hydraulic Wheel Motor Assembly No. 98-2767	9	Rear Access Panel Assembly .....	32
Hydraulic Pump		Electrical Schematic .....	33
Assembly No. 98-8432 and 98-8431 .....	10	Hydraulic Schematic .....	34
Engine Assembly .....	11	Crankshaft (CH20S 64656 Kohler) .....	35
Hydraulic Pump Assembly .....	12	Crankcase (CH20S 64656 Kohler) .....	36
Hydraulic Gear Pump Assembly No. 98-2752 .	14	Oil Pan/Lubrication (CH20S 64656 Kohler) ....	37
Control Panel Assembly .....	15	Head/Valve/Breather (CH20S 64656 Kohler) ..	38
Traction Control Assembly .....	17	Ignition/Electrical (CH20S 64656 Kohler) ....	39
Principal Hydraulic Assembly .....	18	Blower Housing and Baffles	
Two Spool Valve Assembly No. 95-3536 .....	20	(CH20S 64656 Kohler) .....	40
One Spool Valve Assembly No. 104-2831 ....	21	Starting System (CH20S 64656 Kohler) .....	41
Loader Arm Assembly .....	22	Fuel System (CH20S 64656 Kohler) .....	42
Loader Arm Hydraulic Assembly .....	23	Engine Control (CH20S 64656 Kohler) .....	43
Hydraulic Cylinder Assembly No. 99-6162 ....	25	Air Intake/Filtration (CH20S 64656 Kohler) ....	44
Hydraulic Cylinder Assembly No. 95-3578 ....	26	Exhaust (CH20S 64656 Kohler) .....	45

## Accessories

Description	Model / Part No.	Description	Model / Part No.
Dingo TX Heat Shield Kit .....	104-9997	Dingo TX CE Kit .....	22350

## Part Description Abbreviations

Part descriptions in this catalog may include the following abbreviations.

Abbreviation	Meaning	Abbreviation	Meaning
AR .....	as required	HYD .....	hydraulic
ASM .....	assembly	INC .....	incorporated
CARR .....	carriage	LH .....	left hand
DEG .....	degrees	NI .....	nylon insert
FH .....	flat head	PPH .....	Phillips pan head
GA .....	gauge	PTH .....	Phillips truss head
HF .....	hex flange	PTO .....	power take off
HH .....	hex head	RH .....	right hand
HHF .....	hex head flange	SFH .....	slotted fillister head
HLH .....	hex lag head	SHH .....	slotted hex head
HJ .....	hex jam	SQH .....	square head
HOC .....	height-of-cut	SHWH .....	slotted hex washer head
HS .....	hex socket	SPH .....	slotted pan head
HSBH .....	hex socket button head	SRH .....	slotted round head
HSFH .....	hex socket flat head	STD .....	standard
HSH .....	hex socket head	TAP .....	self tapping
HWH .....	hex washer head	TTH .....	Torx truss head
HWHTF .....	hex washer head thread forming	WH .....	wing head

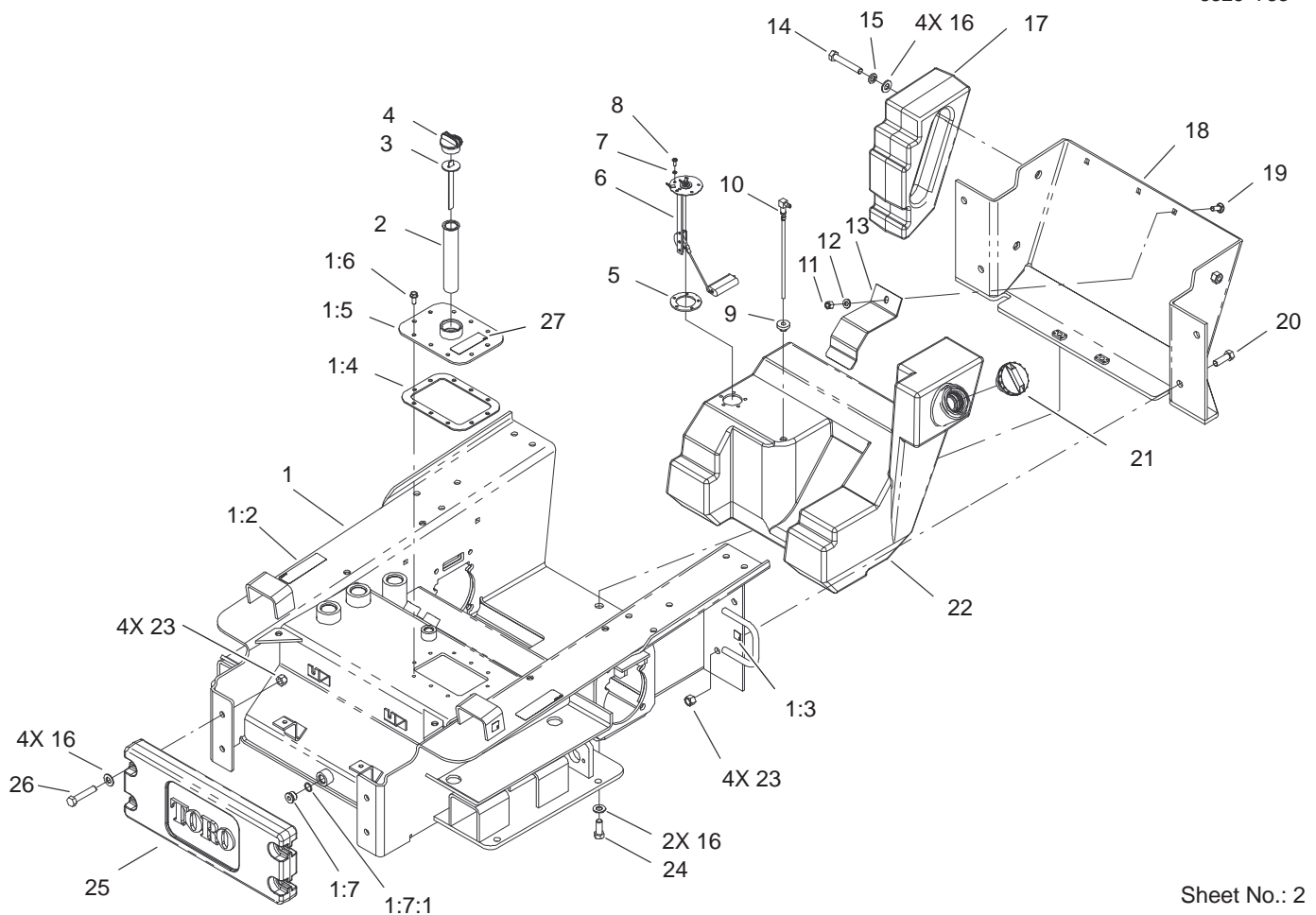

Sheet No.: 2

## Main Frame and Fuel Tank Assembly

Ref. No.	Part No.	Qty.	Description
1	105-0233	1	Main Chassis ASM
1:2	100-6141	2	Decal-Pinch
1:3	93-9084	4	Decal-Point, Lift
1:4	100-1253	1	Gasket-Cover, Access
1:5	104-8389-01	1	Tank Cover ASM
1:6	98-9940	10	Screw
1:7	353-988	1	Plug-Hex, Hollow
1:7:1	237-79	1	O-Ring
2	61-2790	1	Filter-Screen
3	100-2097	1	Dipstick-Oil
4	93-7498	1	Plug-Plastic
5	113372	1	Gasket-Sender, Fuel
6	100-1298	1	Sender-Fuel
7	3253-17	5	Washer-Lock/Sp
8	3250-31	5	Screw-PPH
9	46-6560	1	Bushing
10	98-0185	1	Pipe Stand ASM
11	3296-39	1	Nut-Lock, NI
12	3256-38	1	Washer-Flat
13	100-1257-03	1	Clamp-Tank, Fuel
14	325-12	4	Screw-HH
15	3253-7	4	Washer-Lock
16	3256-26	10	Washer-Flat
17	99-6165-01	2	Counterweight-Rear
18	98-0094-01	1	Rear Frame Cover ASM

Ref. No.	Part No.	Qty.	Description
19	3231-22	1	Screw-CARR
20	325-6	4	Screw-HH
21	93-3101	1	Cap-Fuel
22	95-3619	1	Tank-Fuel
23	3296-23	8	Nut-Lock, NI
24	325-5	2	Screw-HH
25	99-6166-01	1	Counterweight-Front
26	325-10	4	Screw-HH
27	105-6236	1	Decal-Oil, 10w30

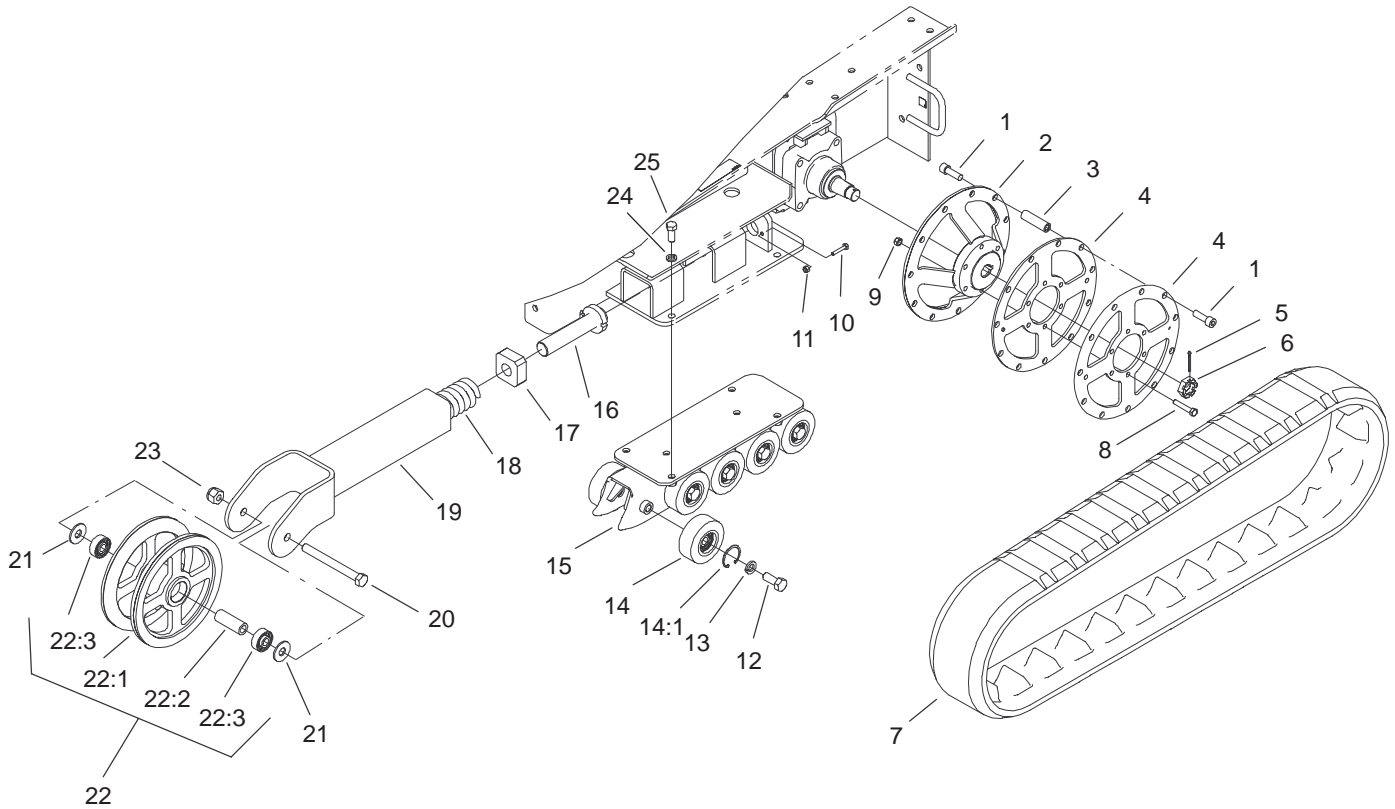

Sheet No.: 3

## Track and Traction Assembly

Ref. No.	Part No.	Qty.	Description
1	3274-4	44	Screw-HSH
2	99-6180-03	2	Drive Wheel ASM
3	100-1286	22	Spacer-Wheel, Drive
4	99-6159-03	4	Plate-Wheel, Drive
5	3272-12	2	Pin-Cotter
6	99-3139	2	Nut-Wheel, Motor
7	98-9800	2	Track-Soucy
8	323-10	12	Screw-HH
9	32153-2	12	Nut-Lock
10	321-13	2	Screw-HH
11	3296-42	2	Nut-Lock, NI
12	327-4	20	Screw-HH
13	3253-8	20	Washer-Lock
14	99-6154	20	Boggy Wheel ASM
14:1	32120-62	1	Ring-Retaining
15	105-5803-03	2	Track Guide ASM
16	98-9846	2	Bolt-Tensioner
17	95-3626	2	Block-Tensioning
18	95-3624	2	Spring-Compression
19	98-9801-03	2	Tensioner Arm ASM
20	327-17	2	Screw-HH
21	3256-7	4	Washer-Flat
22	100-6104	2	Tensioner Wheel ASM
22:1	99-6184-03	1	Tensioner Wheel ASM
22:2	98-9835	1	Spacer-Wheel, Tensioner

Ref. No.	Part No.	Qty.	Description
22:3	93-4237	2	Bearing
23	3296-24	2	Nut-Lock NI
24	3253-7	8	Washer-Lock
25	325-5	8	Screw-HH

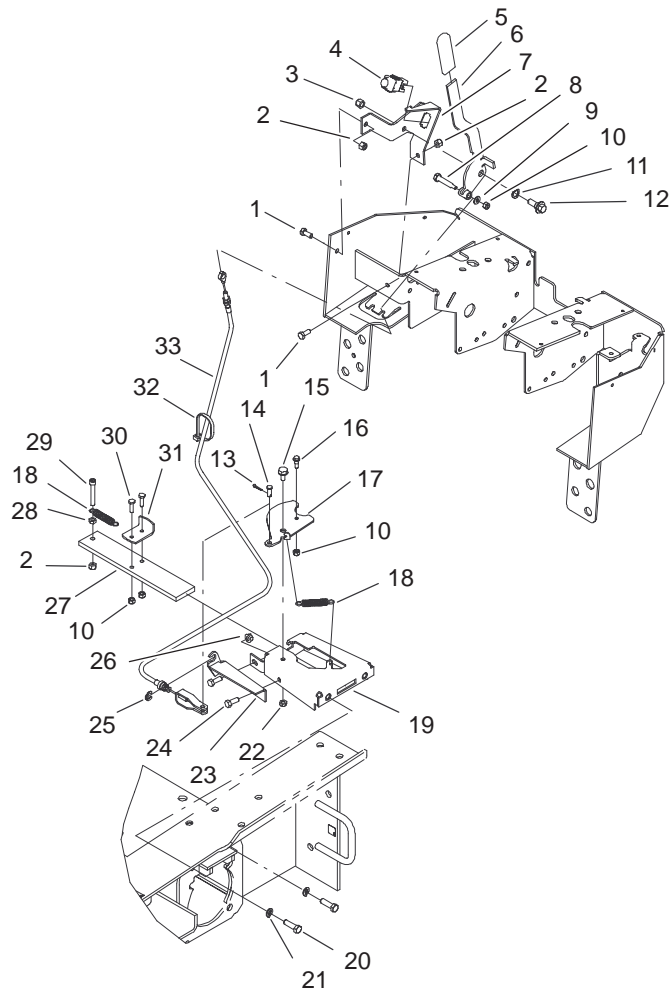

Sheet No.: 5

## Brake Assembly

Ref. No.	Part No.	Qty.	Description	Ref. No.	Part No.	Qty.	Description
1	322-3	2	Screw-HH	26	32128-20	4	Nut-HF
2	3296-29	4	Nut-Lock, NI	27	98-8444-03	2	Plate-Brake
3	3296-6	1	Nut-Lock, NI	28	3218-2	2	Nut-Jam
4	100-1268	1	Switch-Plunger, Snap Mount	29	3274-86	2	Screw-HSH
5	62-9130	1	Grip-Handle	30	321-5	4	Screw-HH
6	99-6151-03	1	Brake Lever ASM	31	98-8448	2	Stop-Brake
7	99-6153-03	1	Bracket-Switch	32	3290-378	2	Tie-Cable
8	611792	1	Bolt-Shoulder	33	100-1283	2	Cable-Brake
9	3256-22	1	Washer-Flat				
10	3296-42	7	Nut-Lock, NI				
11	3290-221	1	Washer-Spring				
12	93-2364	1	Bolt - Shoulder				
13	3272-9	2	Pin-Cotter				
14	283-62	2	Pin-Clevis				
15	37-8771	2	Bolt-Shoulder				
16	42-3560	2	Bolt-Shoulder				
17	98-8443	2	Lever-Brake				
18	87-4020	4	Spring - Extension				
19	100-4200-03	2	Brake Housing ASM				
20	323-7	4	Screw-HH				
21	3253-5	4	Washer-Lock				
22	3296-47	2	Nut-Lock, NI				
23	98-8446-03	2	Bracket-Cable, Brake				
24	322-4	4	Screw-HH				
25	32151-43	2	Klipring				

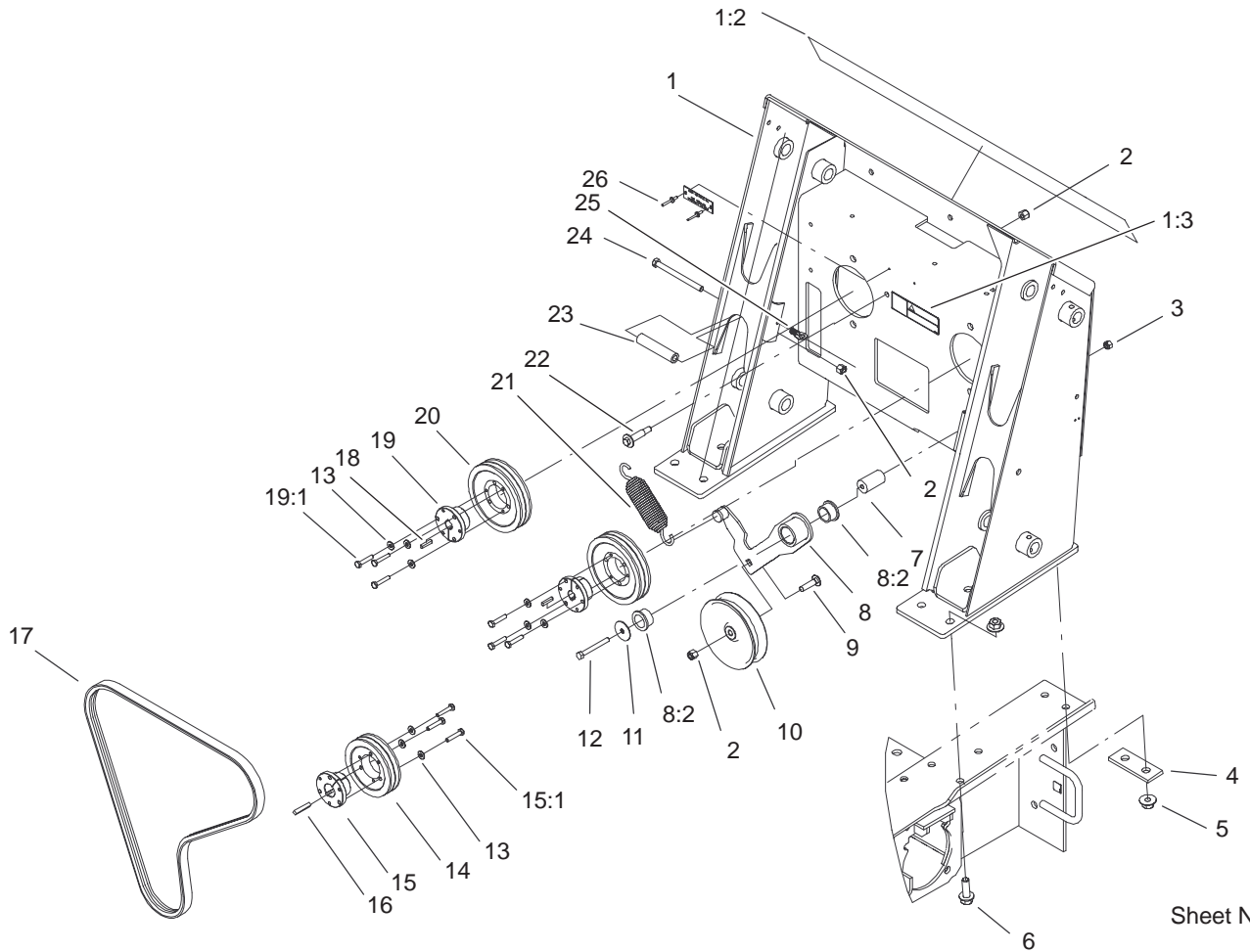

Sheet No.: 6

## Loader Tower and Drive Assembly

Ref. No.	Part No.	Qty.	Description
1	104-2843	1	Loader Tower ASM
1:2	104-2842	1	Decal-Panel
1:3	80-8040	1	Decal-Warning
2	3296-39	4	Nut-Lock, NI
3	3296-29	1	Nut-Lock, NI
4	100-6123-01	2	Plate-Stiffener
5	32128-52	10	Locknut-Flange
6	100-6116	10	Screw-HHF
7	104-5739	1	Spacer-Mounting
8	99-6167	1	Idler Arm ASM
8:2	256-132	2	Bushing-Flange
9	3231-26	1	Screw-CARR
10	95-3707	1	Pulley-Idler
11	3256-68	1	Washer-Flat
12	322-13	1	Screw-HH
13	3256-22	9	Washer-Flat
14	61-3330	1	Pulley
15	61-3340	1	Bushing
15:1	100-4208	3	Screw-HH
16	67-7490	1	Key
17	95-3611	1	V-Belt
18	80-6090	2	Key-Pump
19	100-4206	2	Bushing
19:1	100-4208	3	Screw-HH
20	100-4207	2	Sheave
21	105-0383	1	Spring-Extension

Ref. No.	Part No.	Qty.	Description
22	56-6590	1	Bolt-Wheel
23	100-1271	2	Tube-Spacer
24	323-23	2	Screw-HH
25	95-4013	2	Latch ASM
26	3269-13	2	Rivet-Pop

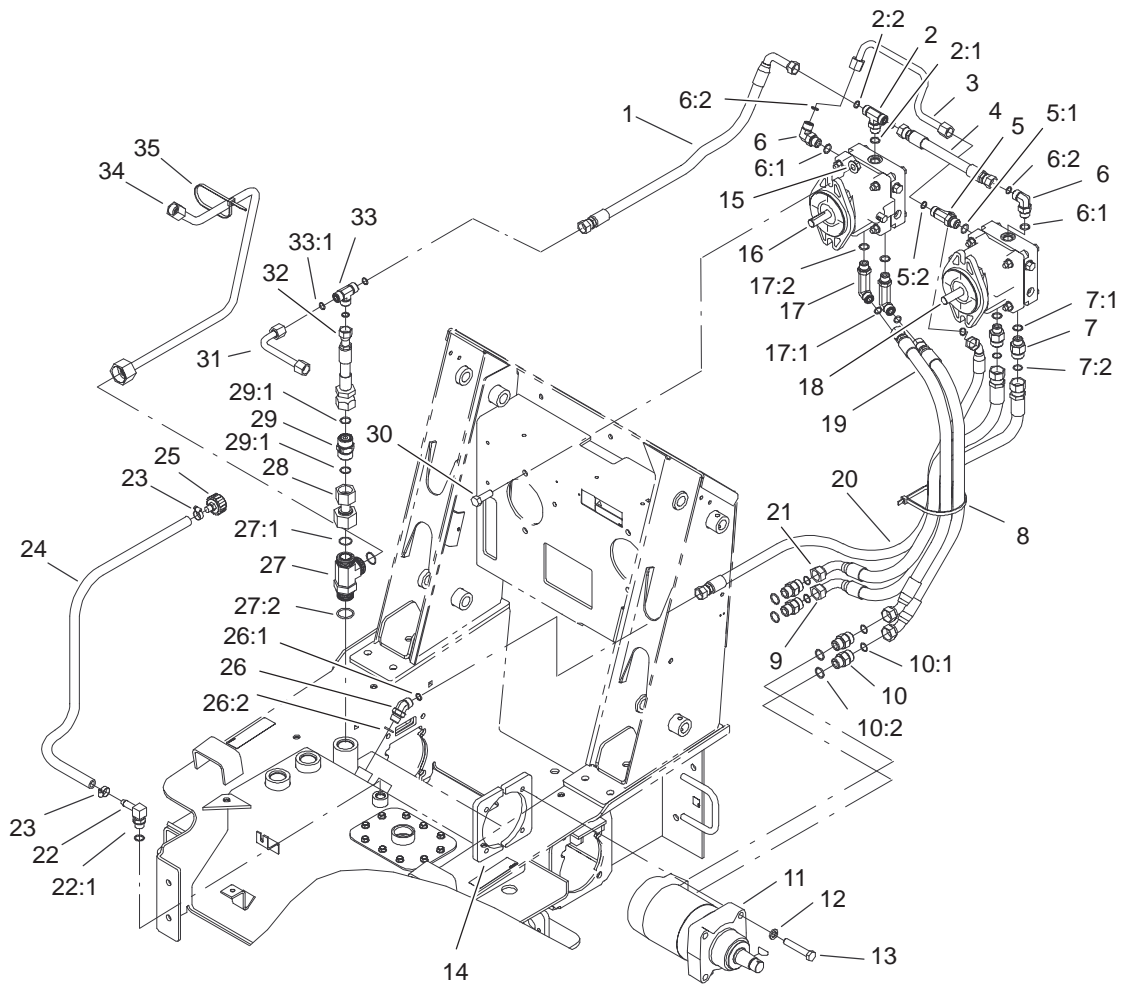

Sheet No.: 7

## Traction Hydraulic Assembly

Ref. No.	Part No.	Qty.	Description
1	100-6130	1	HYD Hose ASM
2	340-157	1	Fitting-HYD
2:1	237-79	1	O-Ring
2:2	237-30	2	O-Ring
3	98-0200	1	HYD Tube ASM
4	95-3664	1	HYD Hose ASM
5	340-109	1	Fitting-HYD
5:1	237-79	1	O-Ring
5:2	237-30	2	O-Ring
6	340-98	2	Fitting-HYD, 90°
6:1	237-79	1	O-Ring
6:2	237-30	1	O-Ring
7	340-155	2	Fitting-HYD
7:1	237-79	1	O-Ring
7:2	237-151	1	O-Ring
8	3334-945	1	Tie-Cable
9	98-0235	1	HYD Hose ASM
10	340-7	4	Adapter
10:1	237-65	1	O-Ring
10:2	237-80	1	O-Ring
11	98-2767	2	Motor-Wheel, HYD
12	3253-7	8	Washer-Lock
13	325-11	8	Screw-HH
14	98-2763-03	4	Plate-Mounting, Wheelmotor
15	32128-23	4	Nut-HF

Ref. No.	Part No.	Qty.	Description
16	98-8431	1	Pump-HYD, RH
17	99-6160	2	Fitting-Elbow, 90°
17:1	237-30	1	O-Ring
17:2	237-79	1	O-Ring
18	98-8432	1	Pump-HYD, LH
19	98-0233	2	HYD Hose ASM
20	98-0201	1	HYD Hose ASM
21	98-0177	1	HYD Hose ASM
22	354-120	1	Fitting-HYD, 90°
22:1	237-79	1	O-Ring
23	2412-36	2	Clamp-Hose
24	98-2708	1	Hose-Vent
25	68-6150	1	Breather-Air
26	340-101	1	Fitting-HYD, 90°
26:1	237-30	1	O-Ring
26:2	237-79	1	O-Ring
27	104-3795	1	Fitting-Tee, HYD
27:1	340-65	2	O-Ring
27:2	237-146	1	O-Ring
28	105-0226	1	HYD Tube ASM
29	99-6161	1	Valve-Check, HYD
29:1	237-58	2	O-Ring
30	325-6	4	Screw-HH
31	95-3517	1	HYD Tube ASM
32	105-0225	1	HYD Hose ASM
33	340-102	1	Adapter





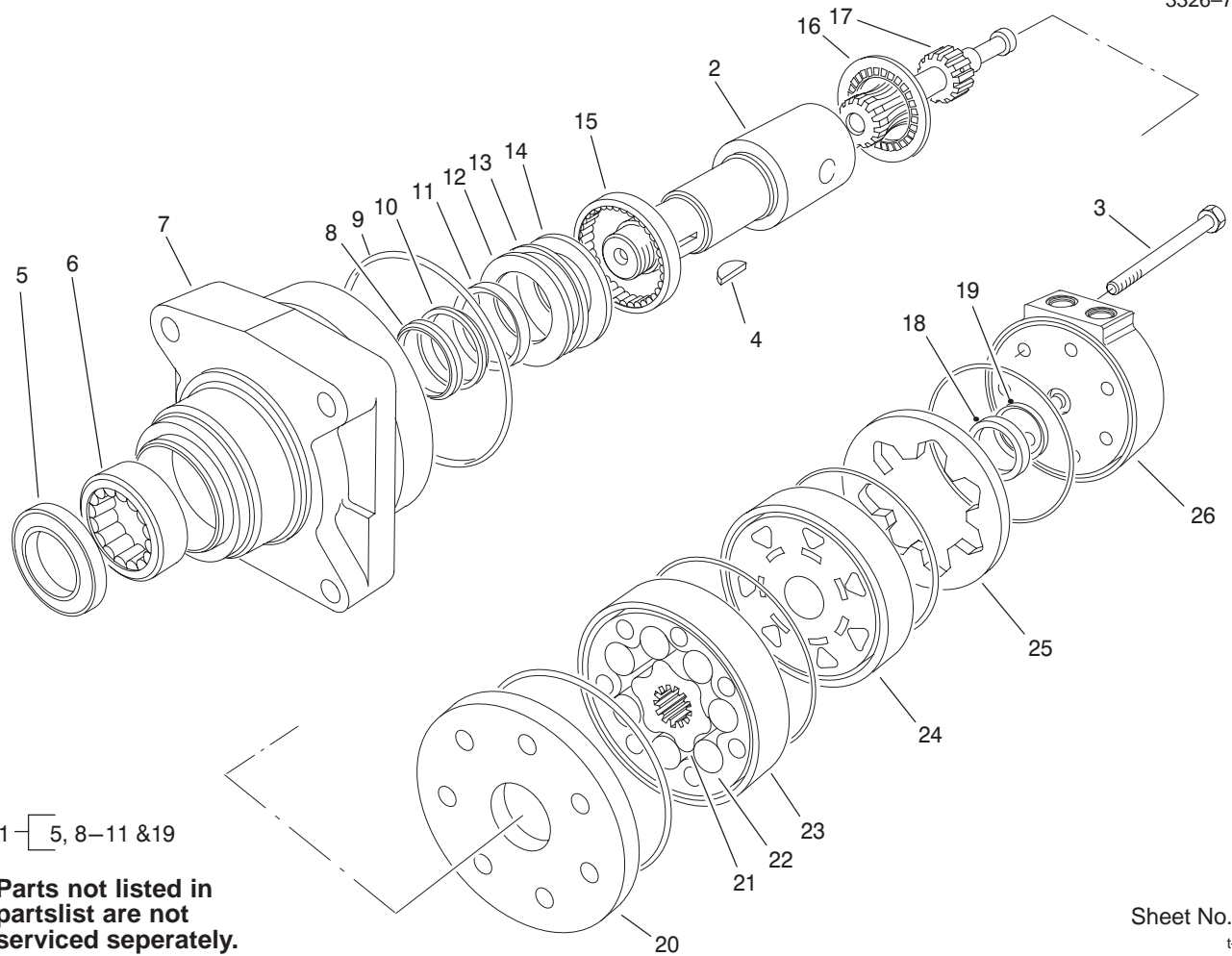

1 — 5, 8-11 & 19

Parts not listed in partslist are not serviced seperately.

Sheet No.: A1  
t-3620

## Hydraulic Wheel Motor Assembly No. 98-2767

Ref. No.	Part No.	Qty.	Description
*1	100-6131	1	Kit-Seal
2	99-3090	1	Coupling-Shaft
3	100-4241	7	Screw-HH
4	3257-42	1	Key-Woodruff

Ref. No.	Part No.	Qty.	Description

\* Not illustrated



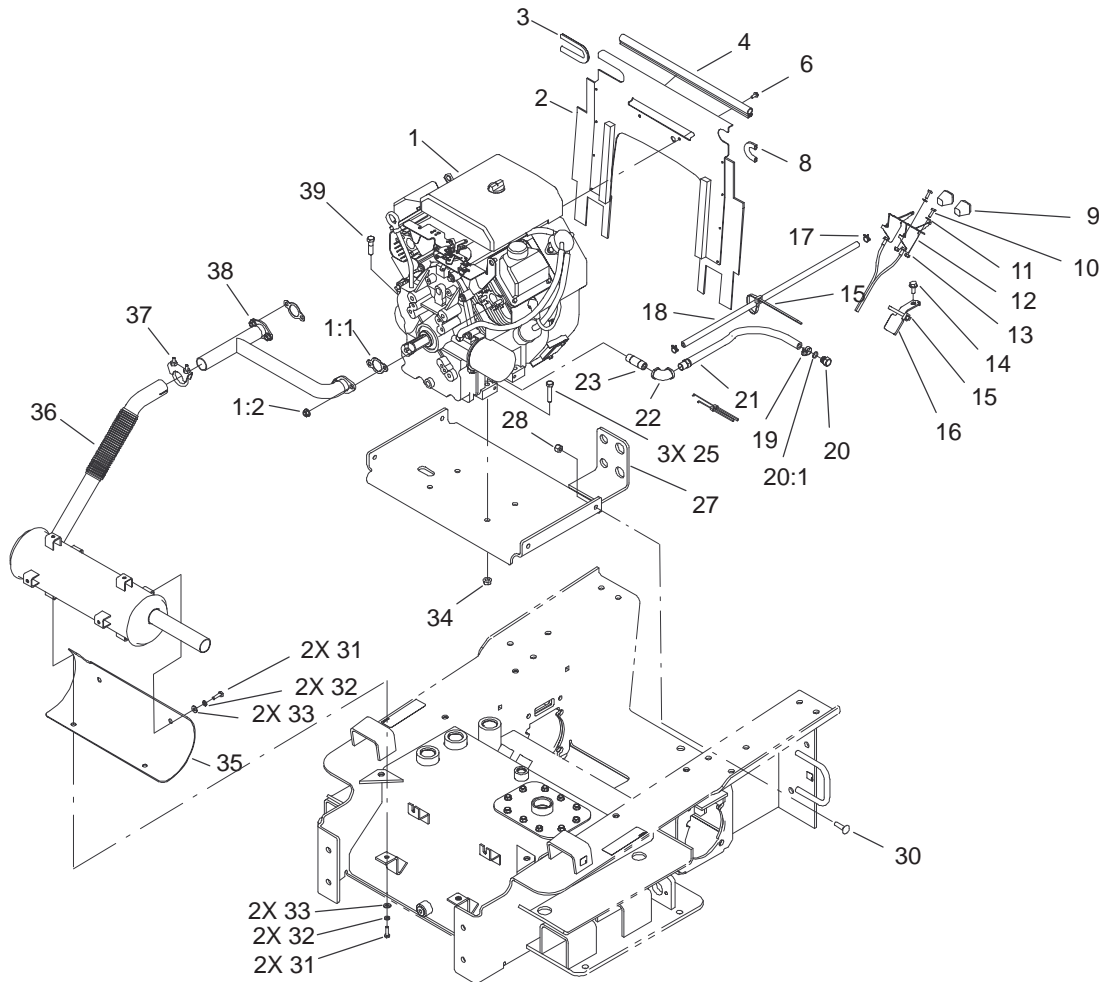

Sheet No.: 8

## Engine Assembly

Ref. No.	Part No.	Qty.	Description
☆1		1	Engine-Kohler, Ch20s-64656
1:1	93-0350	2	Gasket-Exhaust
1:2	92-6780	4	Nut-HF
2	105-5800	1	Baffle-Engine
3	105-0378	1	Seal-Strip, 6.5"
4	105-5801	1	Seal-Strip
6	32144-112	2	Screw-HWHTF
8	105-0377	1	Seal-Strip, 3"
9	66-0120	2	Knob
10	3290-134	4	Screw
11	3256-21	4	Washer-Flat
12	99-6173	2	Cable-Throttle
13	3296-2	4	Nut-Lock
14	32144-70	1	Screw-HH
15	3290-378	2	Tie-Cable
16	100-1299-03	1	Guide-Cable
17	2412-98	2	Clamp
18	105-0376	1	Hose-Fuel
19	2412-119	1	Clamp-Worm
20	353-508	1	Plug
20:1	237-42	1	O-Ring
21	100-1256	1	Oil Hose ASM
22	94-9650	1	Elbow-90°
23	289-42	1	Nipple
25	323-9	3	Screw-HH

Ref. No.	Part No.	Qty.	Description
27	99-6175-03	1	Engine Mounting Plate ASM
28	3296-39	4	Nut-Lock, NI
30	3231-28	4	Screw-CARR
31	321-5	4	Screw-HH
32	3253-3	4	Washer-Lock
33	3256-22	4	Washer-Flat
34	32128-21	4	Nut-HF
35	98-2762	1	Shield-Heat, Muffler
36	98-2759	1	Muffler
37	2112-11	1	Clamp-Muffler
38	98-2761	1	Manifold-Crossover
39	323-8	1	Screw-HH

☆ Not serviced

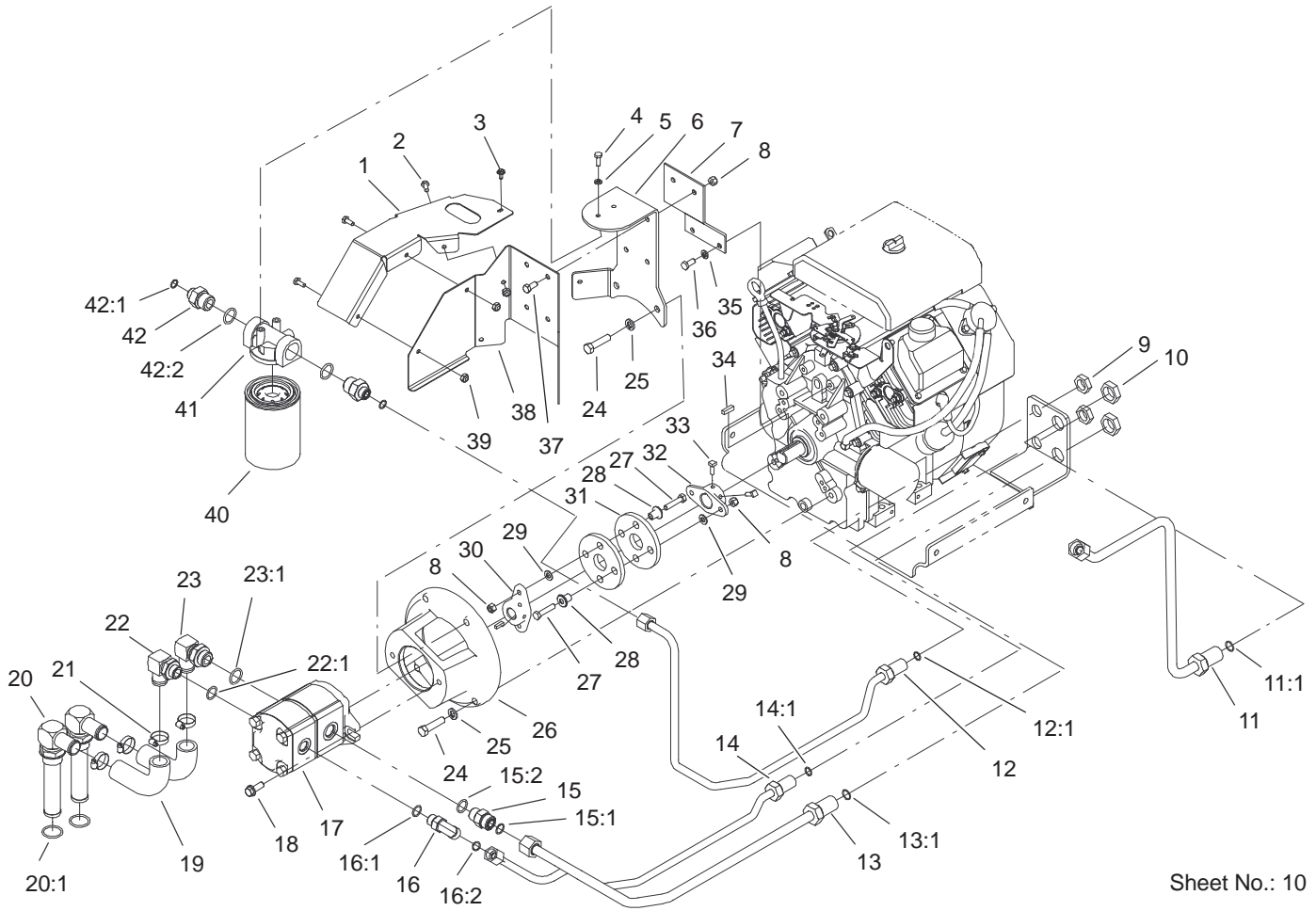

Sheet No.: 10

## Hydraulic Pump Assembly

Ref. No.	Part No.	Qty.	Description
1	104-9960	1	Shield-Heat
2	321-39	4	Screw-HH
3	12-5450	1	Screw
4	321-4	2	Screw-HH
5	3253-3	2	Washer-Lock
6	99-6172-03	1	Bracket-Support, Oil Filter
7	99-6171-03	1	Bracket-Support, Oil Filter
8	3296-29	8	Nut-Lock, NI
9	340-127	2	Nut-Bulkhead
10	340-74	2	Locknut-Bulkhead
11	104-5705	1	HYD Tube ASM
11:1	237-65	1	O-Ring
12	98-2780	1	HYD Tube ASM
12:1	237-30	1	O-Ring
13	98-2783	1	HYD Tube ASM
13:1	237-65	1	O-Ring
14	98-2781	1	HYD Tube ASM
14:1	237-30	1	O-Ring
15	340-7	1	Adapter
15:1	237-65	1	O-Ring
15:2	237-80	1	O-Ring
16	340-98	1	Fitting-HYD, 90°
16:1	237-79	1	O-Ring
16:2	237-30	1	O-Ring

Ref. No.	Part No.	Qty.	Description
17	98-2752	1	Pump-Gear, HYD
18	66-9300	2	Screw-HF
19	105-0201	2	Hose-Suction, Formed
20	105-0204	2	Strainer Fitting ASM
20:1	237-146	1	O-Ring
21	2412-34	4	Clamp-Hose
22	61-2710	1	Stem-Hose, 90°
22:1	237-117	1	O-Ring
23	100-4202	1	Fitting-90°
23:1	237-81	1	O-Ring
24	324-7	4	Screw-HH
25	3253-6	4	Washer-Lock
26	98-2751	1	Mount - Pump
27	322-7	4	Screw-HH
28	71-4411	4	Spacer
29	3256-23	4	Washer-Flat
30	49-9600	1	Hub-Pump
31	44-2230	2	Coupling-Rubber
32	27-1960	1	Hub-Engine
33	3241-6	4	Screw-SQH
34	10-7070	1	Key-Square
35	3253-4	2	Washer-Lock
36	33114-020	2	Screw-HH
37	322-3	4	Screw-HH
38	100-6114	1	Shield-Heat, Filter





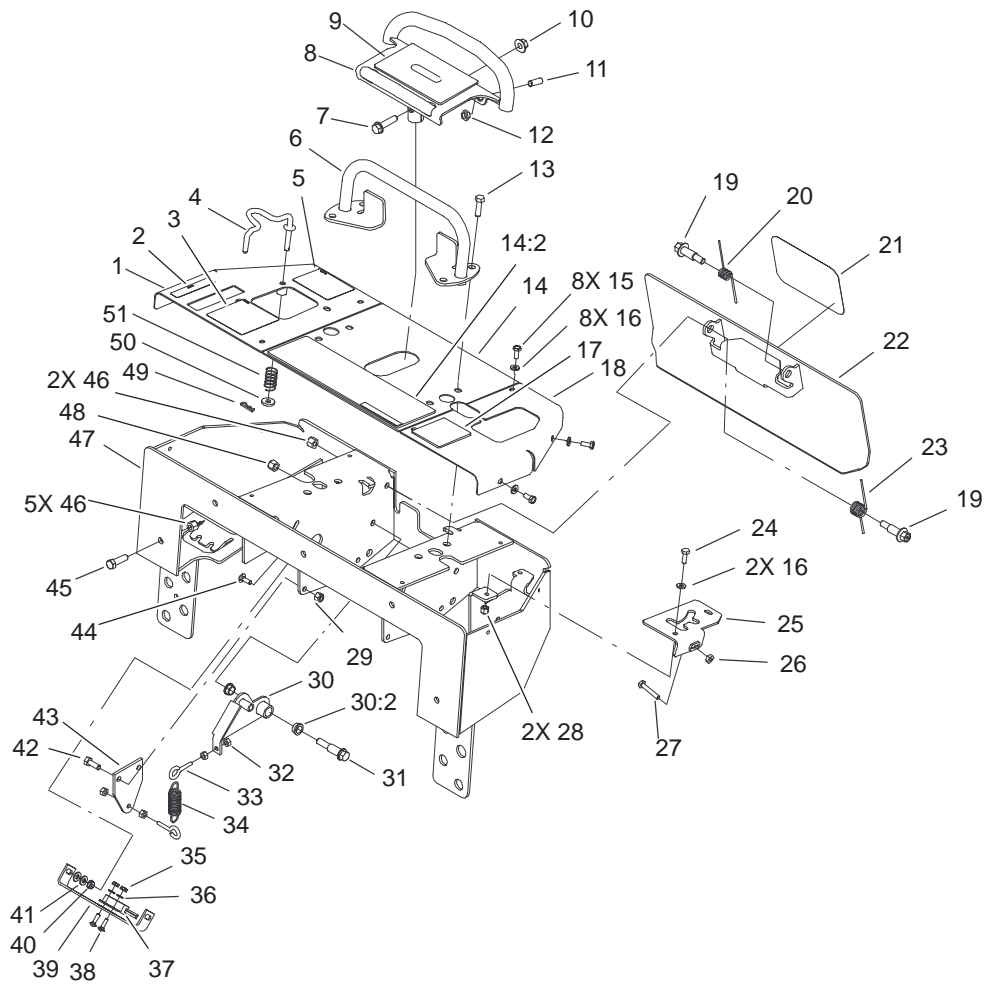

Sheet No.: 11

## Control Panel Assembly

Ref. No.	Part No.	Qty.	Description	Ref. No.	Part No.	Qty.	Description
1	104-2836-01	1	RH Panel ASM	26	3218-1	1	Nut-Jam
2	104-2838	1	Decal-Brake	27	321-9	1	Screw-HH
3	104-2837	1	Decal-Loader	28	3296-8	2	Nut-Lock NI
4	104-2833	1	Rod-Interlock	29	3296-29	2	Nut-Lock, NI
5	104-2844	1	Decal-Interlock	30	100-4203	1	Neutral Centering Lever ASM
6	98-8400-03	1	Reference Bar ASM	30:2	256-156	2	Bushing-Flange
7	3234-18	1	Screw-HHF	31	66-0560	1	Bolt-Shoulder
8	104-9970-03	1	Control Handle ASM	32	3217-5	4	Nut-Hex
9	100-6138	1	Decal-Traction	33	71-2870	2	Bolt-Eye
10	32128-43	1	Nut-Flange	34	105-1210	1	Spring - Extension
11	3247-6	2	Screw-Set	35	32149-7	2	Nut-Keps
12	3218-3	2	Nut-Jam	36	3256-51	2	Washer-Flat
13	322-16	4	Screw-HH	37	100-1270	1	Switch-Proximity
14	100-6144	1	Center Panel ASM	38	3229-20	2	Screw-CARR
14:2	100-6140	1	Decal-Danger	39	100-1263	1	Plate-Switch
15	32144-44	8	Screw-HWH	40	32149-2	2	Nut
16	3256-16	10	Washer-Flat	41	3256-22	4	Washer-Flat
17	100-6136	1	Decal-Auxiliary	42	322-4	2	Screw-HH
18	98-8428-01	1	Panel-LH	43	100-1261-03	1	Bracket-Spring
19	62-1330	2	Bolt-Shoulder	44	3229-1	2	Screw-CARR
20	98-8424	1	Spring-Torsion, RH	45	323-7	5	Screw-HH
21	105-1217	1	Decal - Toro	46	3296-39	7	Nut-Lock, NI
22	98-8417-03	1	Reverse Plate ASM	47	95-3540-01	1	Control Panel ASM
23	98-8425	1	Spring-Torsion, LH	48	3296-6	1	Nut-Lock, NI
24	321-4	2	Screw-HH	49	3290-307	1	Pin-Hair
25	100-6126-01	1	Auxiliary Stop ASM				

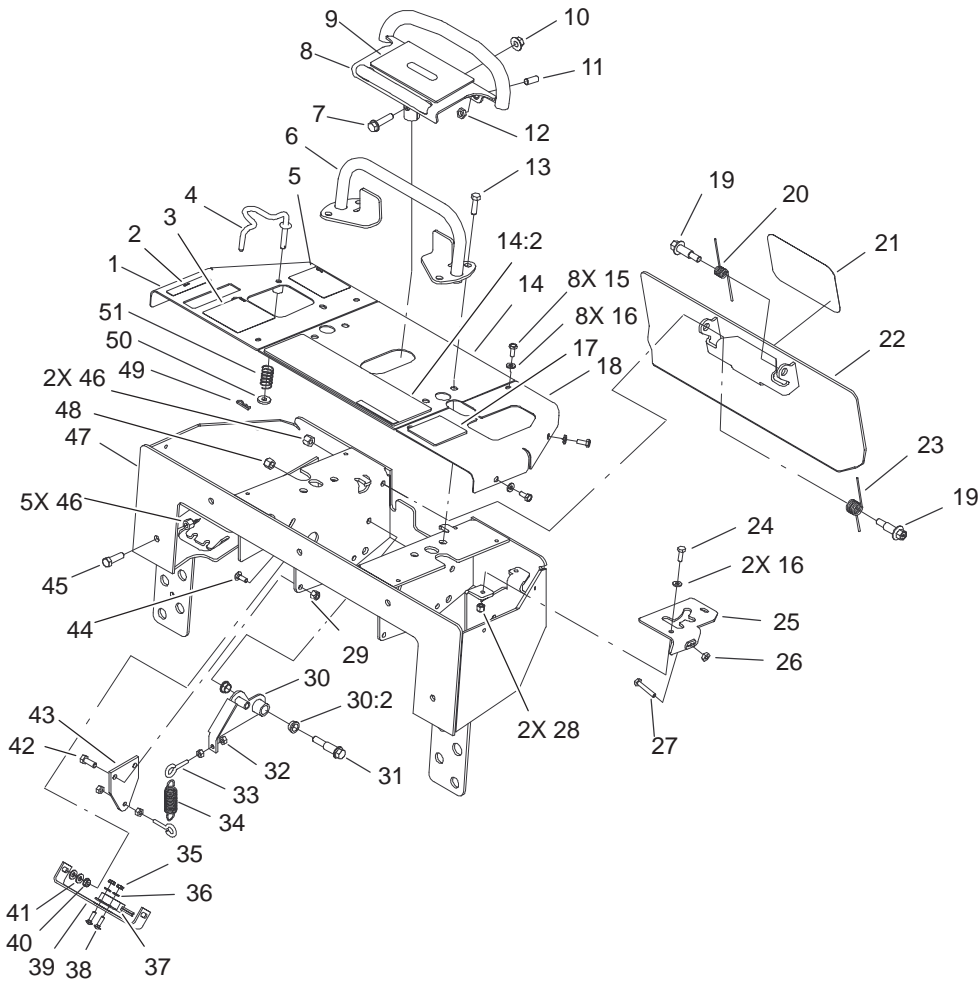

Sheet No.: 11

## Control Panel Assembly

Ref. No.	Part No.	Qty.	Description
50	88-7200	1	Washer-Flat
51	85-6750	1	Spring-Control

Ref. No.	Part No.	Qty.	Description
----------	----------	------	-------------



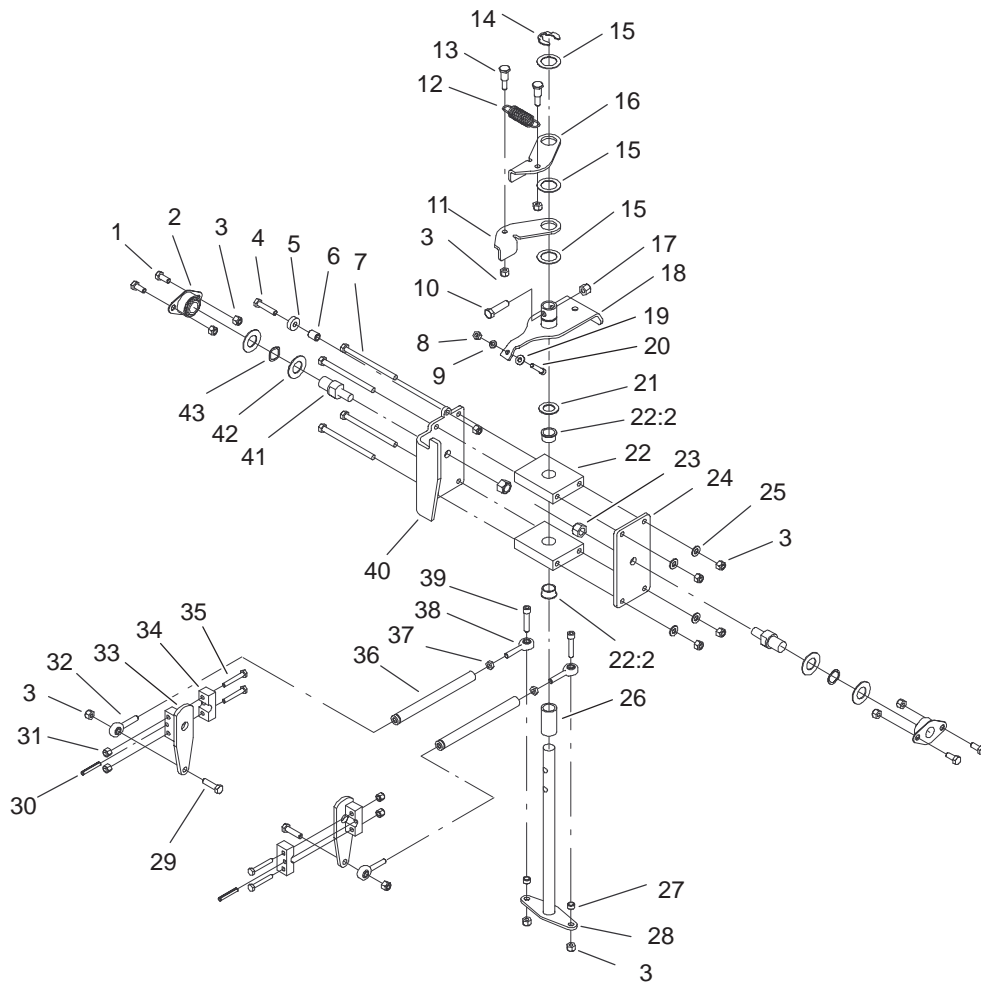

Sheet No.: 12

## Traction Control Assembly

Ref. No.	Part No.	Qty.	Description	Ref. No.	Part No.	Qty.	Description
1	322-3	4	Screw-HH	25	3256-23	4	Washer-Flat
2	68-2970	2	Bushing	26	104-9974	1	Spacer-Pivot, Rod
3	3296-29	15	Nut-Lock, NI	27	92-3133	2	Spacer-Lever, Traction
4	322-7	1	Screw-HH	28	98-8411	1	Drive Rod ASM
5	251-259	1	Bearing	29	322-6	2	Screw-HH
6	88-7450	1	Spacer-Lever, Control	30	100-6148	2	Pin-Spring, Metric
7	322-38	4	Screw-HH	31	3296-8	4	Nut-Lock NI
8	3217-5	1	Nut-Hex	32	2411-53	2	Bearing-Rod End, LH
9	3253-3	1	Washer-Lock	33	98-8433	2	Pump Lever ASM
10	323-8	1	Screw-HH	34	98-8434	2	Clamp-Traction
11	98-8407	1	Lever-Return, RH	35	321-10	4	Screw-HH
12	105-1210	1	Spring - Extension	36	95-3711	2	Rod-Linkage
13	63-2650	2	Screw-Shoulder	37	3220-2	2	Nut
14	32151-91	1	Ring-Retaining	38	2411-52	2	Bearing-Rod End, RH
15	3256-42	3	Washer-Flat	39	3274-83	2	Screw-HSH
16	98-8408	1	Lever-Return, LH	40	104-9976-03	1	Bracket-Pivot, RH
17	3296-39	1	Nut-Lock, NI	41	95-3684	2	Shaft-Arm, Pivot
18	104-9968	1	Pivot Lever ASM	42	3256-39	6	Washer-Flat
19	3256-22	1	Washer-Flat	43	95-3703	2	Washer-Spring, Wave
20	3274-51	1	Screw-HSH				
21	257-8	1	Washer-Thrust				
22	104-9972	2	Bearing Support Block ASM				
22:2	256-252	1	Bearing-Flange				
23	3296-23	2	Nut-Lock, NI				
24	104-9975-03	1	Bracket-Pivot, LH				

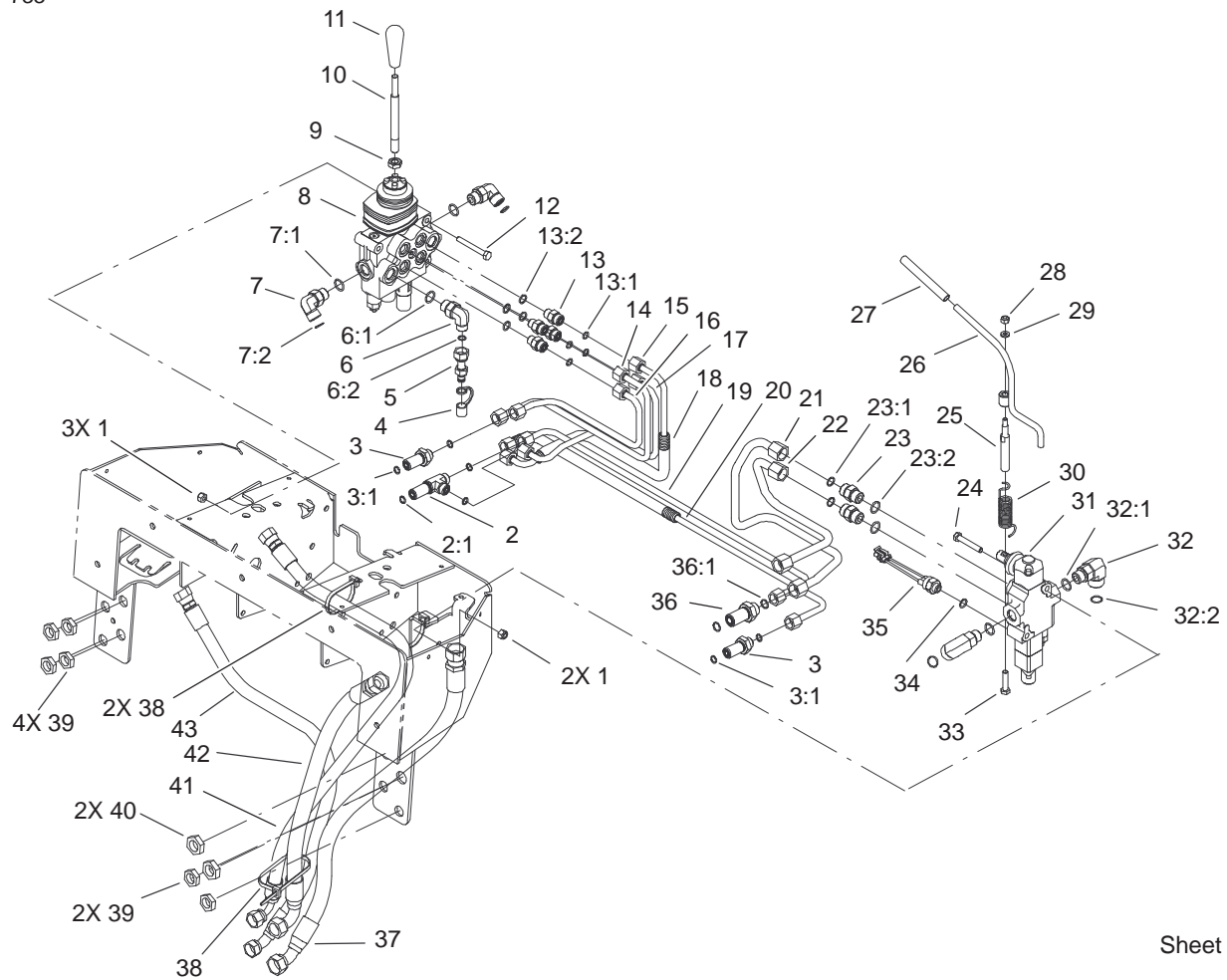

Sheet No.: 13

## Principal Hydraulic Assembly

Ref. No.	Part No.	Qty.	Description
1	3296-29	5	Nut-Lock, NI
2	340-68	2	Fitting-Tee, Bulkhead
2:1	237-22	3	O-Ring
3	340-71	4	Fitting-Straight, Bulkhead
3:1	237-22	2	O-Ring
4	354-79	1	Cap-Dust, Yellow
5	86-5480	1	Nipple-Test
6	340-18	1	Fitting-HYD, 90°
6:1	237-79	1	O-Ring
6:2	237-22	1	O-Ring
7	340-98	2	Fitting-HYD, 90°
7:1	237-79	1	O-Ring
7:2	237-30	1	O-Ring
8	95-3536	1	Valve-2 Spool
9	51-2070	1	Nut
10	95-3569	1	Shaft-Handle, Lift/Tilt
11	98-0152	1	Knob-Tapered
12	322-12	3	Screw-HH
13	340-2	4	Fitting-HYD, Straight
13:1	237-22	1	O-Ring
13:2	237-42	1	O-Ring
14	98-2788	1	HYD Tube ASM
15	98-2784	1	HYD Tube ASM
16	98-2789	1	HYD Tube ASM
17	98-2785	1	HYD Tube ASM

Ref. No.	Part No.	Qty.	Description
18	100-1287	2	Conduit-Convolutd
19	98-2787	1	HYD Tube ASM
20	98-2786	1	HYD Tube ASM
21	98-2790	1	HYD Tube ASM
22	98-2791	1	HYD Tube ASM
23	340-4	2	Adapter
23:1	237-30	1	O-Ring
23:2	237-79	1	O-Ring
24	322-11	2	Screw-HH
25	104-2827	1	Spacer-Hiflo
26	100-4246	1	Auxiliary Lever ASM
27	92-6798	1	Cap-Rod, Tilt
28	3296-42	1	Nut-Lock, NI
29	3256-16	1	Washer-Flat
30	100-6129	1	Spring-Torsion
31	104-2831	1	Valve-1 Spool
32	340-153	2	Fitting-HYD
32:1	237-79	1	O-Ring
32:2	237-151	1	O-Ring
33	48-7740	1	Screw
34	237-42	1	O-Ring
35	72-4310	1	Switch
36	340-161	2	Fitting-Bulkhead
36:1	237-30	2	O-Ring
37	98-0203	1	HYD Hose ASM
38	3290-378	3	Tie-Cable



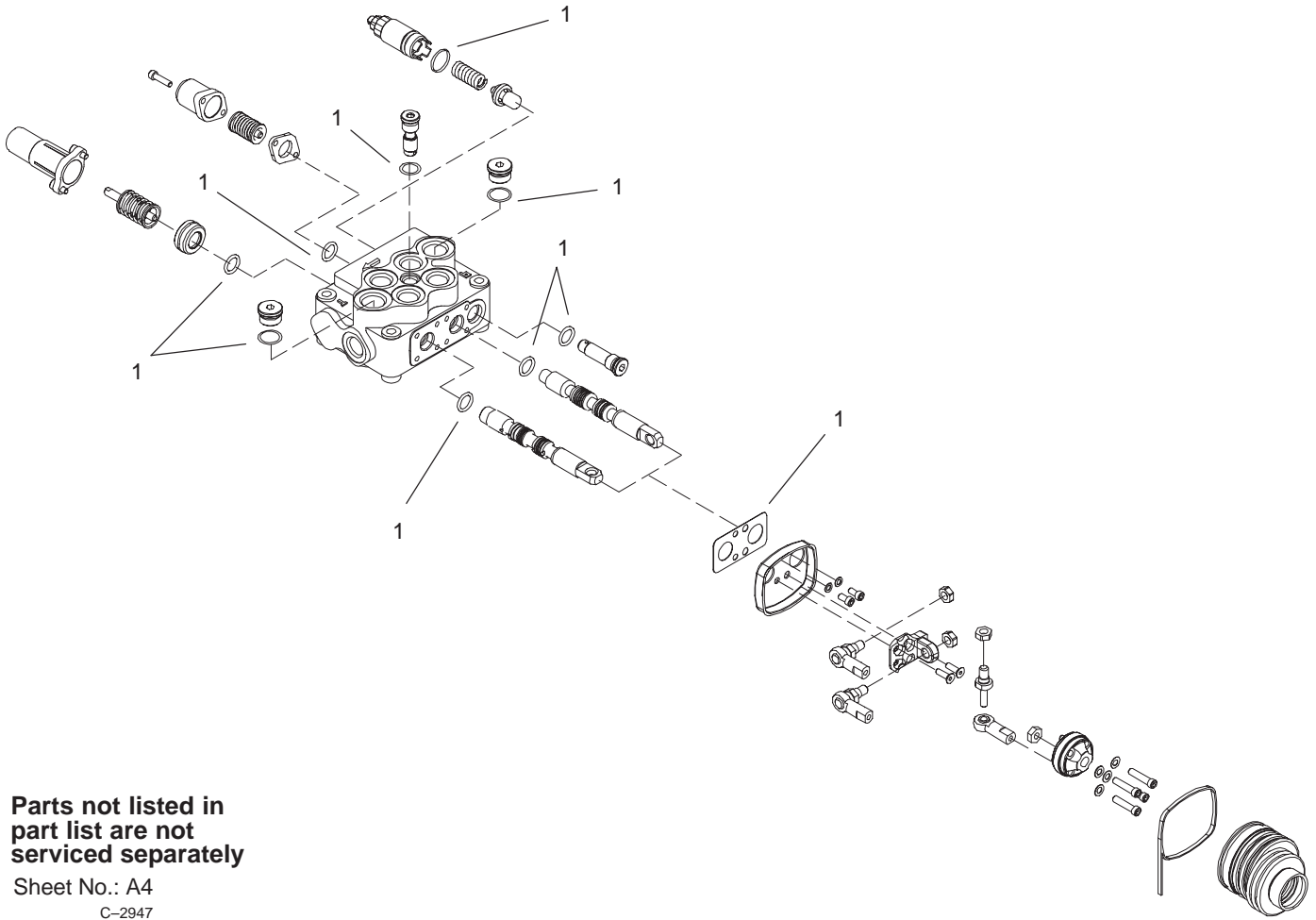

Parts not listed in  
part list are not  
serviced separately

Sheet No.: A4  
C-2947

## Two Spool Valve Assembly No. 95-3536

Ref. No.	Part No.	Qty.	Description
1	100-4249	1	Kit-Seal

Ref. No.	Part No.	Qty.	Description
----------	----------	------	-------------





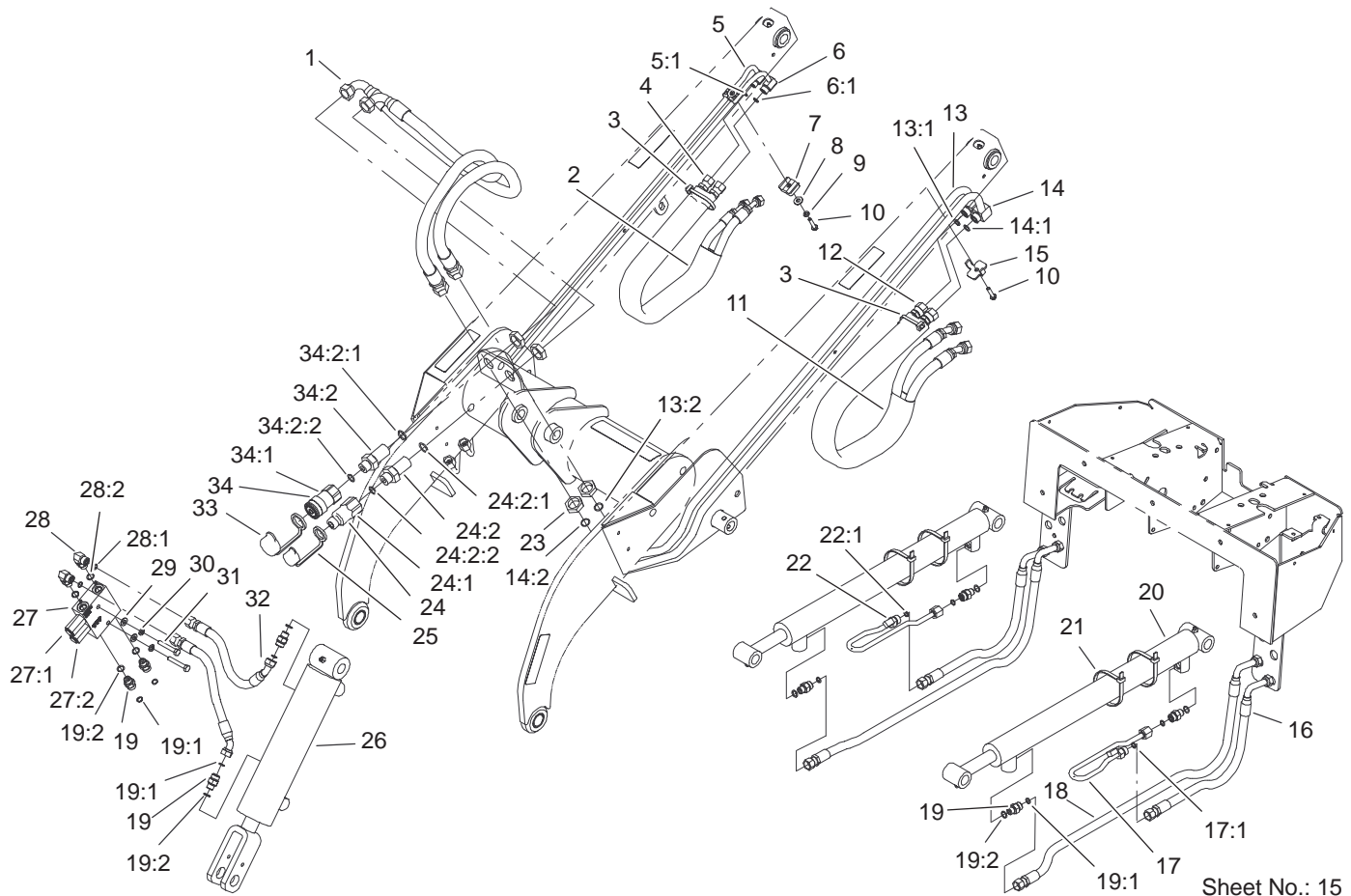

Sheet No.: 15

## Loader Arm Hydraulic Assembly

Ref. No.	Part No.	Qty.	Description
1	99-6193	2	HYD Hose ASM
2	100-6127	1	Sleeve-Protective
3	3290-378	2	Tie-Cable
4	98-0213	2	HYD Hose ASM
5	104-9965	1	HYD Tube ASM
5:1	237-22	1	O-Ring
6	104-9964	1	HYD Tube ASM
6:1	237-22	1	O-Ring
7	56-7973	2	Clamp-Tube
8	3256-2	1	Washer-Flat
9	3253-3	1	Washer-Lock
10	32144-110	2	Screw-HWH
11	100-6128	1	Sleeve-Protective
12	98-0242	2	HYD Hose ASM
13	104-9962	1	HYD Tube ASM
13:1	237-30	1	O-Ring
13:2	237-65	1	O-Ring
14	104-9963	1	HYD Tube ASM
14:1	237-30	1	O-Ring
14:2	237-65	1	O-Ring
15	98-0237	1	Plate-Clamp,Tube
16	98-0216	2	HYD Hose ASM
17	100-1259	1	HYD Tube ASM
17:1	237-22	1	O-Ring
18	98-0217	2	HYD Hose ASM
19	340-2	8	Fitting-HYD, Straight

Ref. No.	Part No.	Qty.	Description
19:1	237-22	2	O-Ring
19:2	237-42	2	O-Ring
20	99-6162	2	Cylinder-Lift
21	3334-945	4	Tie-Cable
22	100-1258	1	HYD Tube ASM
22:1	237-22	1	O-Ring
23	340-74	4	Locknut-Bulkhead
24	100-4748	1	Bulkhead Nipple ASM
24:1	96-1276	1	Nipple-Face, Flush
24:2	100-4236	1	Fitting-Adapter, Bulkhead
24:2:1	237-65	1	O-Ring
24:2:2	237-80	1	O-Ring
25	100-8815	1	Cap-Dust, Nipple
26	95-3578	1	Cylinder-Tilt
27	100-4205	1	Valve-Relief, Crossover
*27:1	100-4219	2	Kit-Seal
27:2	100-4220	1	Cartridge-Relief
27:3	100-4221	1	Cartridge-Relief
28	340-77	2	Fitting-HYD, 90°
28:1	237-22	1	O-Ring
28:2	237-42	1	O-Ring
29	3256-23	2	Washer-Flat
30	3253-4	2	Washer-Lock
31	322-10	2	Screw-HH

\* Not illustrated





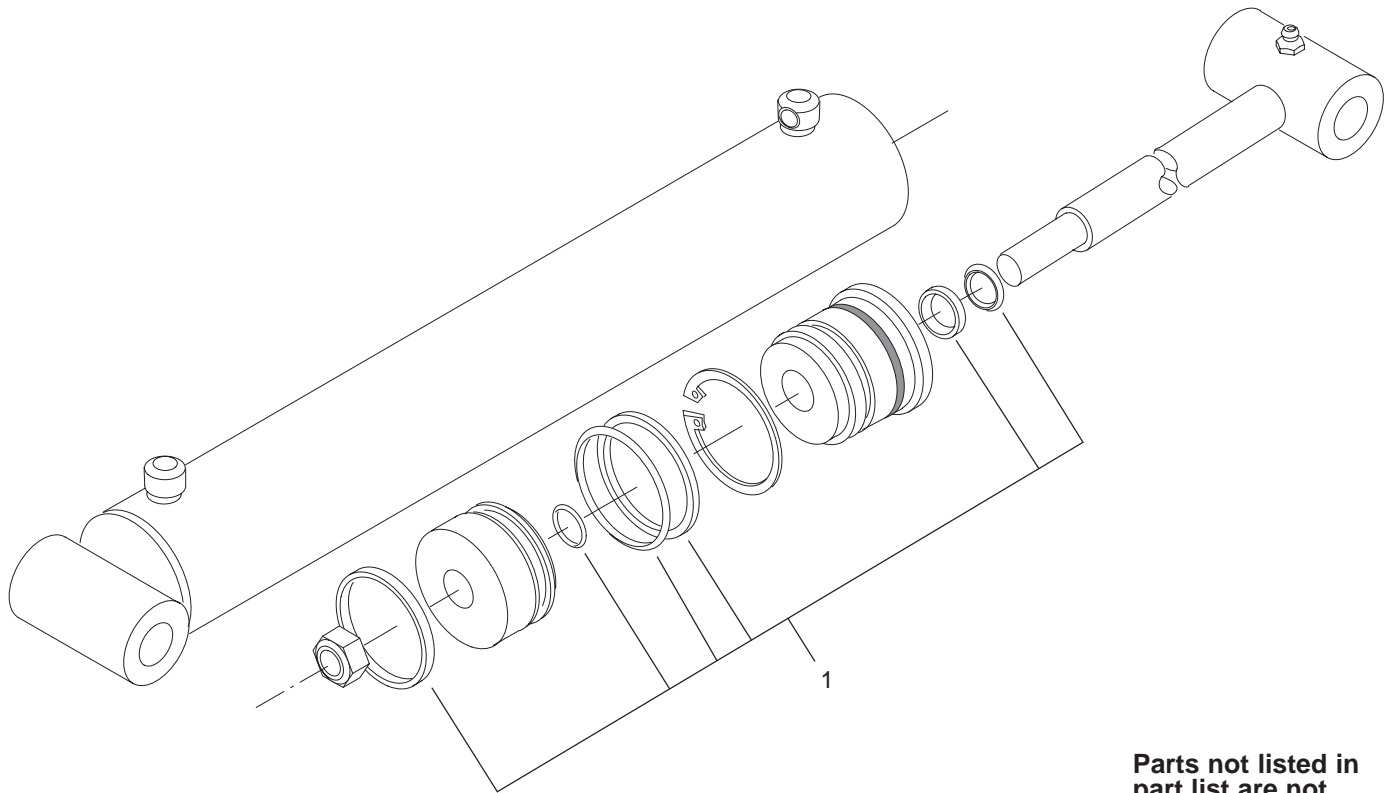

**Parts not listed in  
part list are not  
serviced separately**

Sheet No.: A6  
C-3619

## Hydraulic Cylinder Assembly No. 99-6162

Ref. No.	Part No.	Qty.	Description
1	100-6107	1	Kit-Seal

Ref. No.	Part No.	Qty.	Description

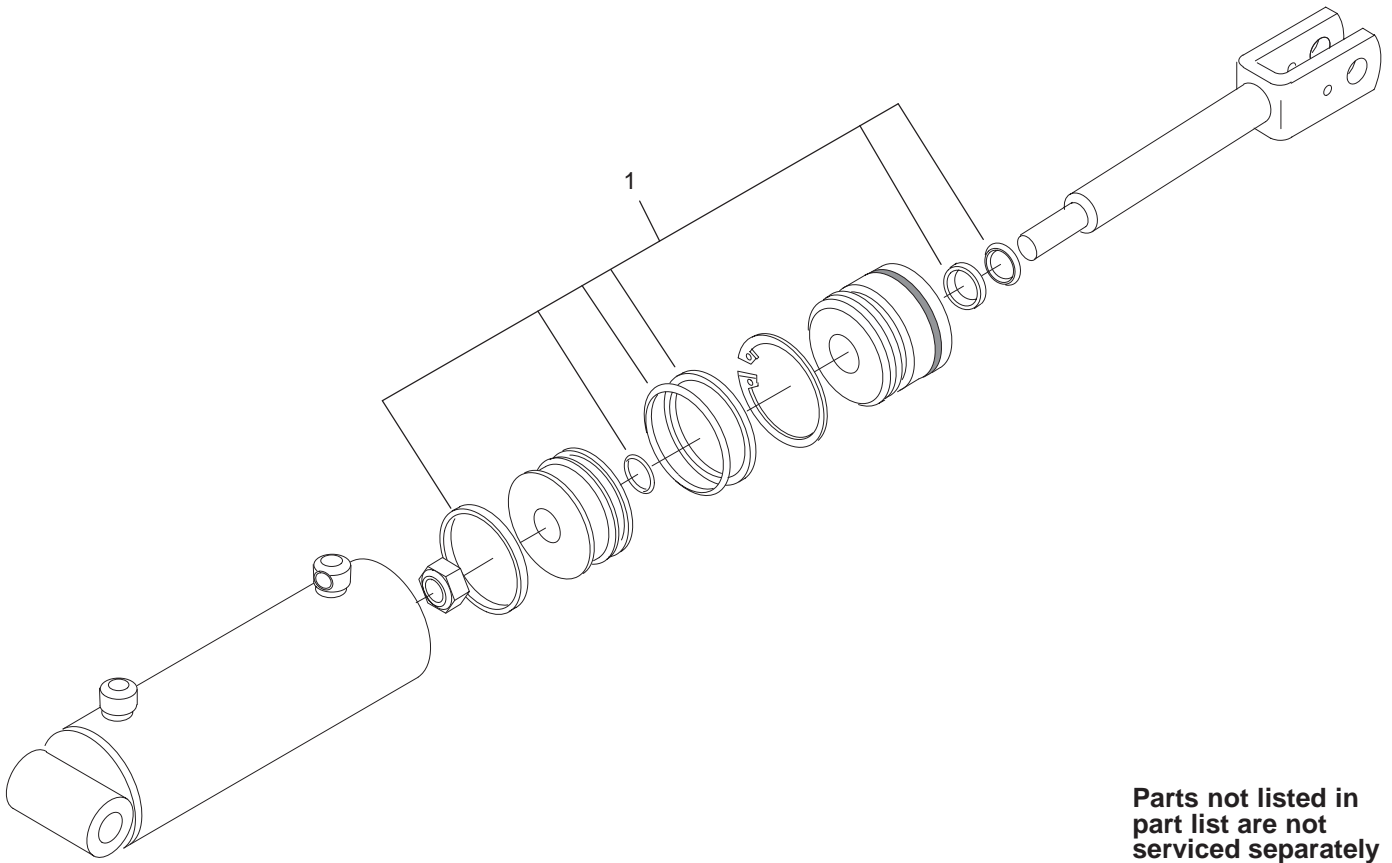

**Parts not listed in  
part list are not  
serviced separately**

Sheet No.: A7  
C-3618

## Hydraulic Cylinder Assembly No. 95-3578

Ref. No.	Part No.	Qty.	Description
1	100-6108	1	Kit-Seal

Ref. No.	Part No.	Qty.	Description
----------	----------	------	-------------

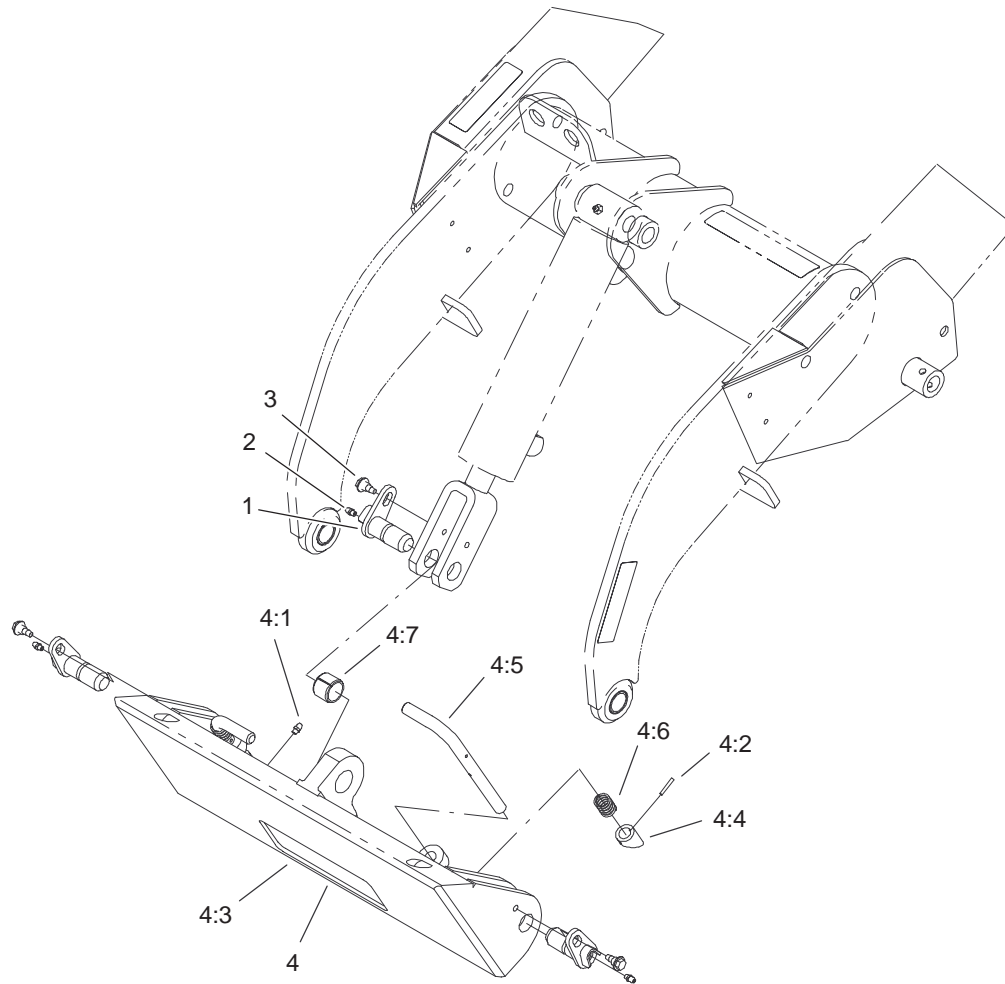

Sheet No.: 16

## Quick Attach Assembly

Ref. No.	Part No.	Qty.	Description
1	99-1414	3	Pin-Pivot
2	302-5	3	Fitting-Grease
3	99-5105	3	Bolt-Shoulder
4	98-4690	1	Quick Attach ASM
4:1	302-5	2	Fitting-Grease
4:2	32121-94	2	Pin-Special
4:3	98-4691-03	1	Mount-Attach, Quick
4:4	98-4692	2	Cam-Attach, Quick
4:5	100-3373	2	Pin
4:6	98-4694	2	Spring-Compression
4:7	98-4871	1	Bushing-Tension

Ref. No.	Part No.	Qty.	Description

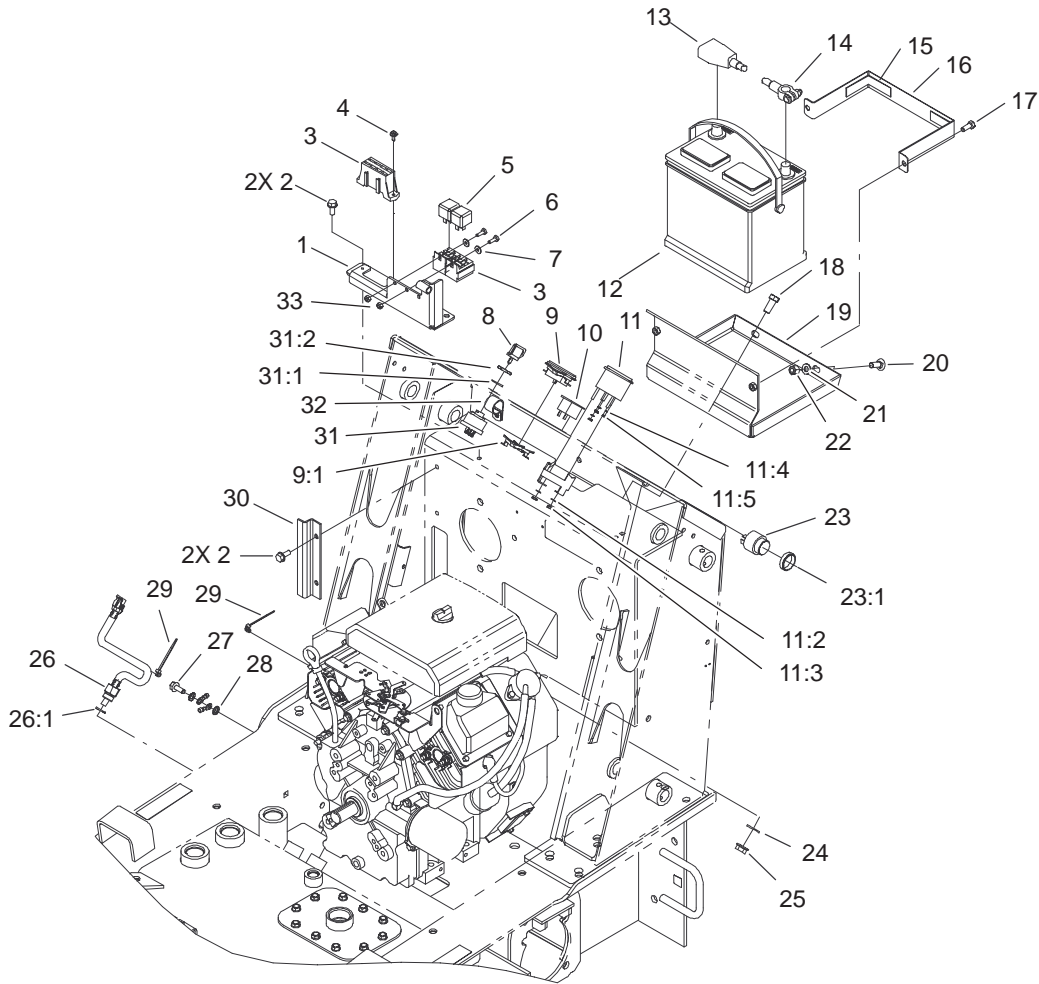

Sheet No.: 17

## Electrical Assembly

Ref. No.	Part No.	Qty.	Description
1	100-1291-03	1	Bracket-Fuse/Relay
2	32144-70	4	Screw-HH
3	104-7412	1	Harness-Wire
*3:1	114594	1	Fuse-10 Amp
*3:2	109102	1	Fuse-25 Amp
*3:3	NN10277	1	Fuse-30 Amp
*3:4	109355	1	Fuse-15 Amp
4	12-5450	2	Screw
5	98-7249	2	Relay
6	3290-134	2	Screw
7	3256-49	2	Washer-Flat
8	63-8360	1	Key-Ignition
9	104-7427	1	Hourmeter-Inductive
9:1	104-4234	1	Clip-Mounting
10	104-2839	1	Light-Temp, Oil
11	66-2940	1	Gauge-Fuel
11:2	3254-1	2	Washer-Lock, Internal
11:3	3217-27	2	Nut-Hex
11:4	3255-24	3	Washer-Lock/Ext
11:5	3217-16	3	Nut-Hex
12	104-9979	1	Battery (Dry)
13	99-6185	1	Cable-Battery, Positive
14	99-6186	1	Cable-Battery, Negative
15	94-9566	2	Pad-Footrest

Ref. No.	Part No.	Qty.	Description
16	98-2795-03	1	Bracket-Clamp, Battery
17	322-4	2	Screw-HH
18	324-4	2	Screw-HH
19	98-2793-03	1	Battery Tray ASM
20	3231-22	2	Screw-CARR
21	3256-38	2	Washer-Flat
22	3296-39	2	Nut-Lock, NI
23	80-9330	1	Alarm-Audio
23:1	104-5107	1	Nut-Plastic, Knurled
24	3256-4	2	Washer-Flat
25	32128-42	2	Nut-HF
26	98-2765	1	Sensor-Temperature
26:1	237-79	1	O-Ring
27	33104-020	1	Screw-HHF
28	3255-8	2	Washer-Lock/Ext
29	3290-381	2	Tie - Cable
30	100-6117-01	1	Shield-Wiring
31	88-9830	1	Key Switch ASM
31:1	3254-5	1	Washer-Lock, Internal
31:2	218-461	1	Nut-HH
32	2412-39	1	R-Clamp
33	3296-2	2	Nut-Lock

\* Not illustrated

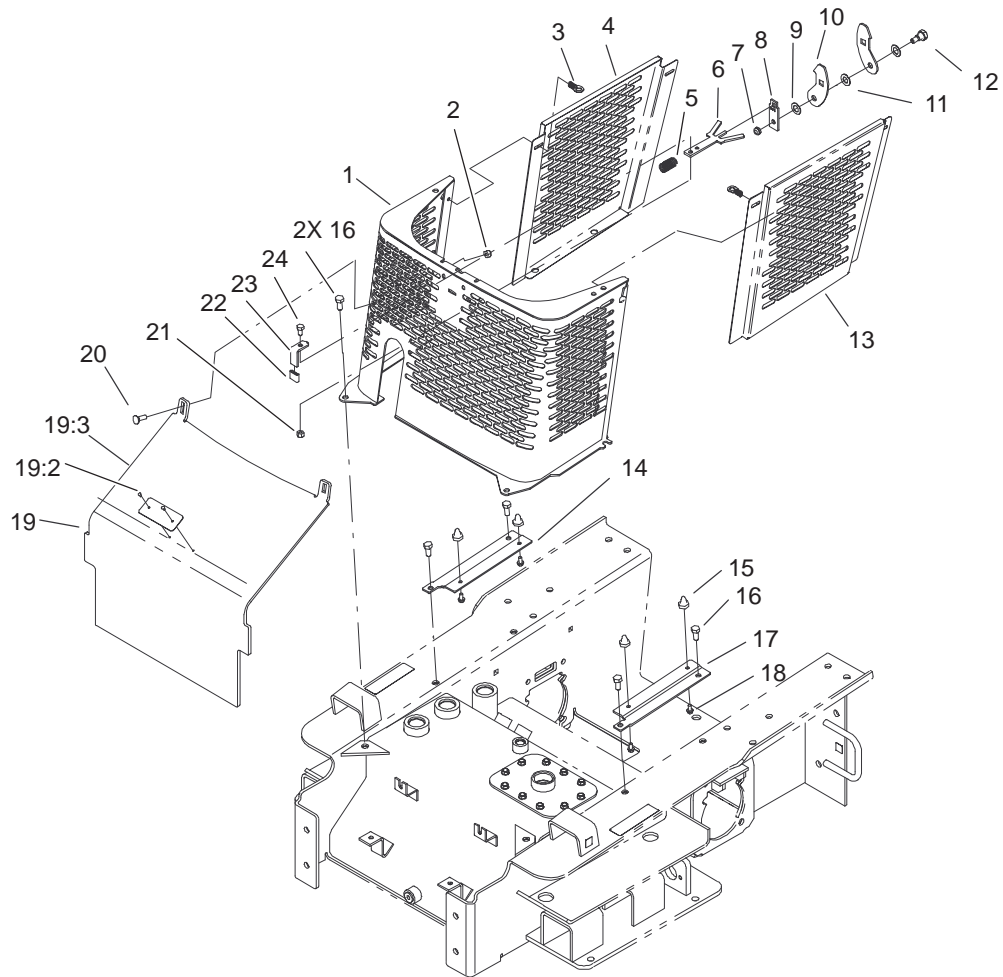

Sheet No.: 18

## Grill Assembly

Ref. No.	Part No.	Qty.	Description	Ref. No.	Part No.	Qty.	Description
1	100-1282-03	1	Grill ASM	23	100-4223	1	Handle-Latch
2	3296-29	2	Nut-Lock, NI	24	322-2	1	Screw-HH
3	95-4013	2	Latch ASM				
4	105-0380-03	1	Panel-Side, RH				
5	100-6102	1	Spring-Compression				
6	100-4226	1	Lever-Latch				
7	3296-59	1	Nut-Lock NI				
8	100-4225	1	Spacer-Latch				
9	47-2910	1	Washer-Thrust				
10	100-4224	2	Latch-Hood				
11	257-10	2	Washer-Thrust				
12	27-5240	1	Bolt-Shoulder				
13	105-0379-03	1	Panel-Side, LH				
14	100-1280-03	1	Support-Side Panel, RH				
15	95-3989	4	Mount-Sidepanel				
16	323-5	6	Screw-HH				
17	100-1281-03	1	Support-Side Panel, LH				
18	46-8093	4	Screw-Plastite				
19	104-9985	1	Heat Shield ASM				
19:2	80-8290	1	Plate-Surface, Hot				
19:3	3269-31	2	Rivet-Pop				
20	3230-28	2	Screw-CARR				
21	3296-29	1	Nut-Lock, NI				
22	100-1655	1	Grip-Handle				



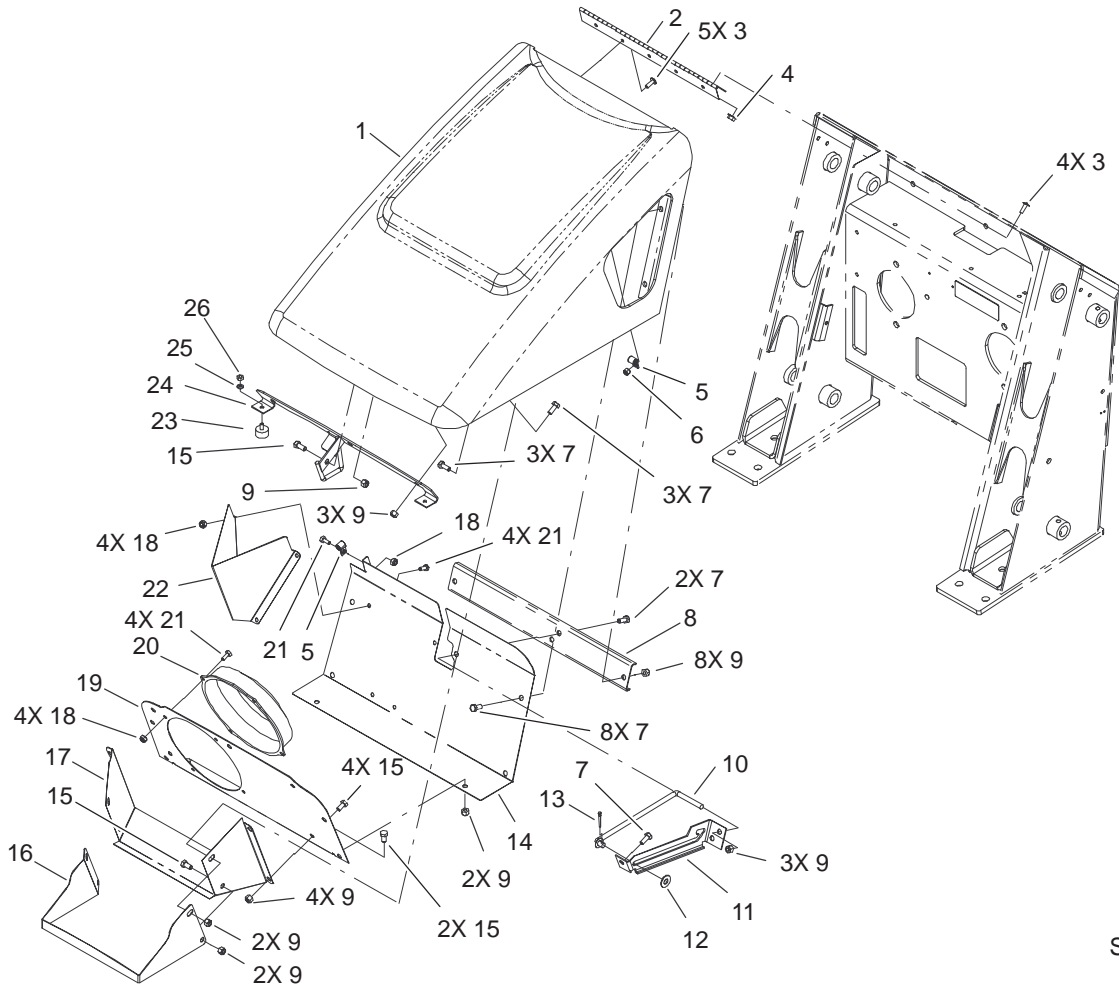

Sheet No.: 20

## Hood Assembly

Ref. No.	Part No.	Qty.	Description
1	100-4222	1	Engine Hood ASM
2	100-1284	1	Hinge-Hood
3	9114604	9	Screw-Head, Truss
4	32128-33	4	Nut-HF
5	2412-91	2	Clamp
6	3296-42	5	Nut-Lock, NI
7	322-3	17	Screw-HH
8	100-4212-03	1	Support-Bracket, Rod/Hood
9	3296-29	25	Nut-Lock, NI
10	100-4229	1	Rod-Support, Hood
11	100-1292-03	1	Bracket-Rod/Hood
12	3256-4	1	Washer-Flat
13	3272-11	1	Pin-Cotter
14	104-2815-03	1	Panel-Rack, Fan
15	322-2	8	Screw-HH
16	104-2813-03	1	Shroud-Fan, Front
17	104-2812-03	1	Shroud-Fan
18	3296-16	9	Nut-Lock, NI
19	104-2814-03	1	Plate-Baffle, Fan
20	104-2809	1	Fan-12v
21	321-3	9	Screw-HH
22	104-2811-03	1	Baffle-Fan
23	240-14	2	Bumper-Rubber
24	100-1297-03	1	Rod Latch ASM

Ref. No.	Part No.	Qty.	Description
25	3253-3	2	Washer-Lock
26	3217-5	2	Nut-Hex





# Electrical Schematic

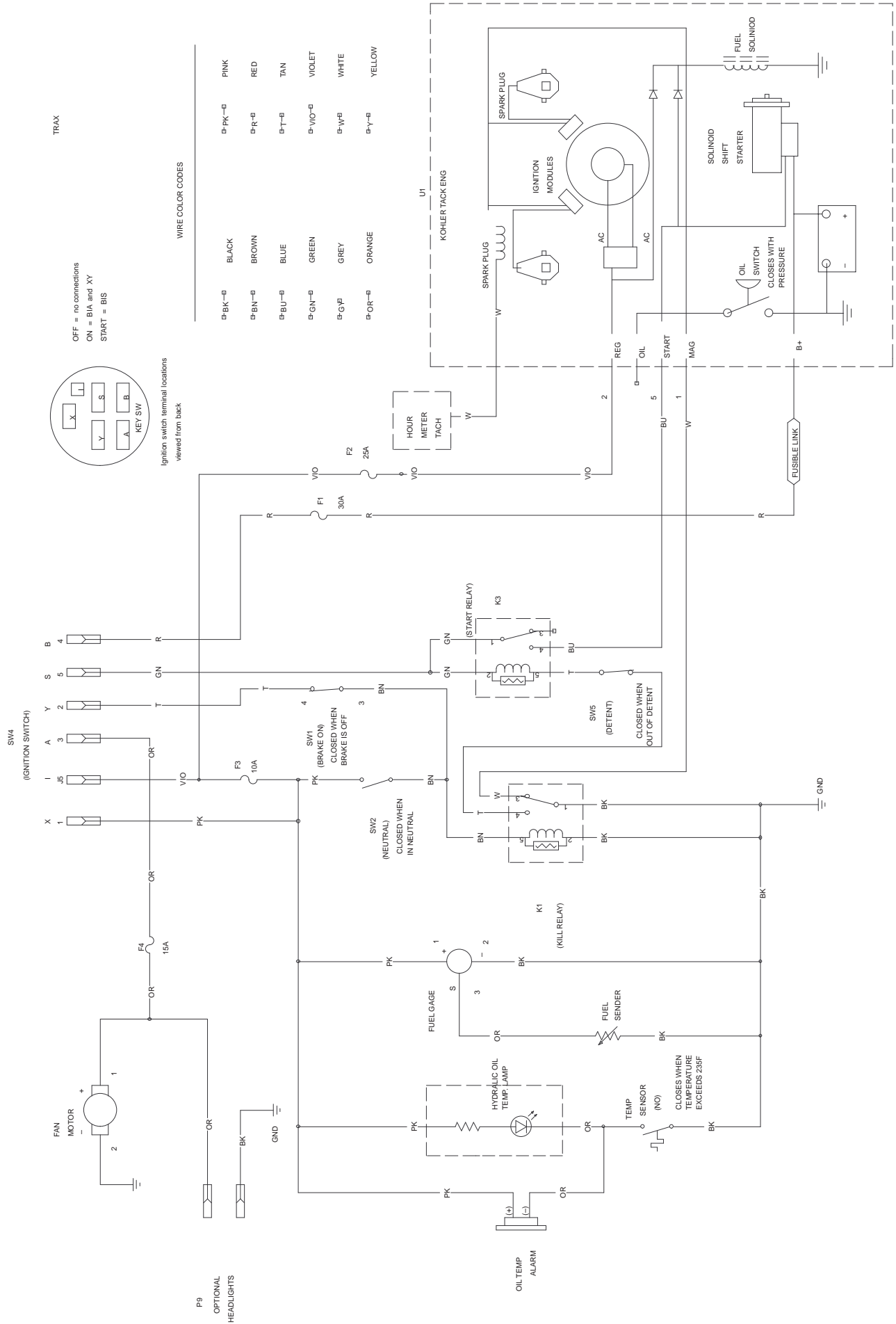

# Hydraulic Schematic

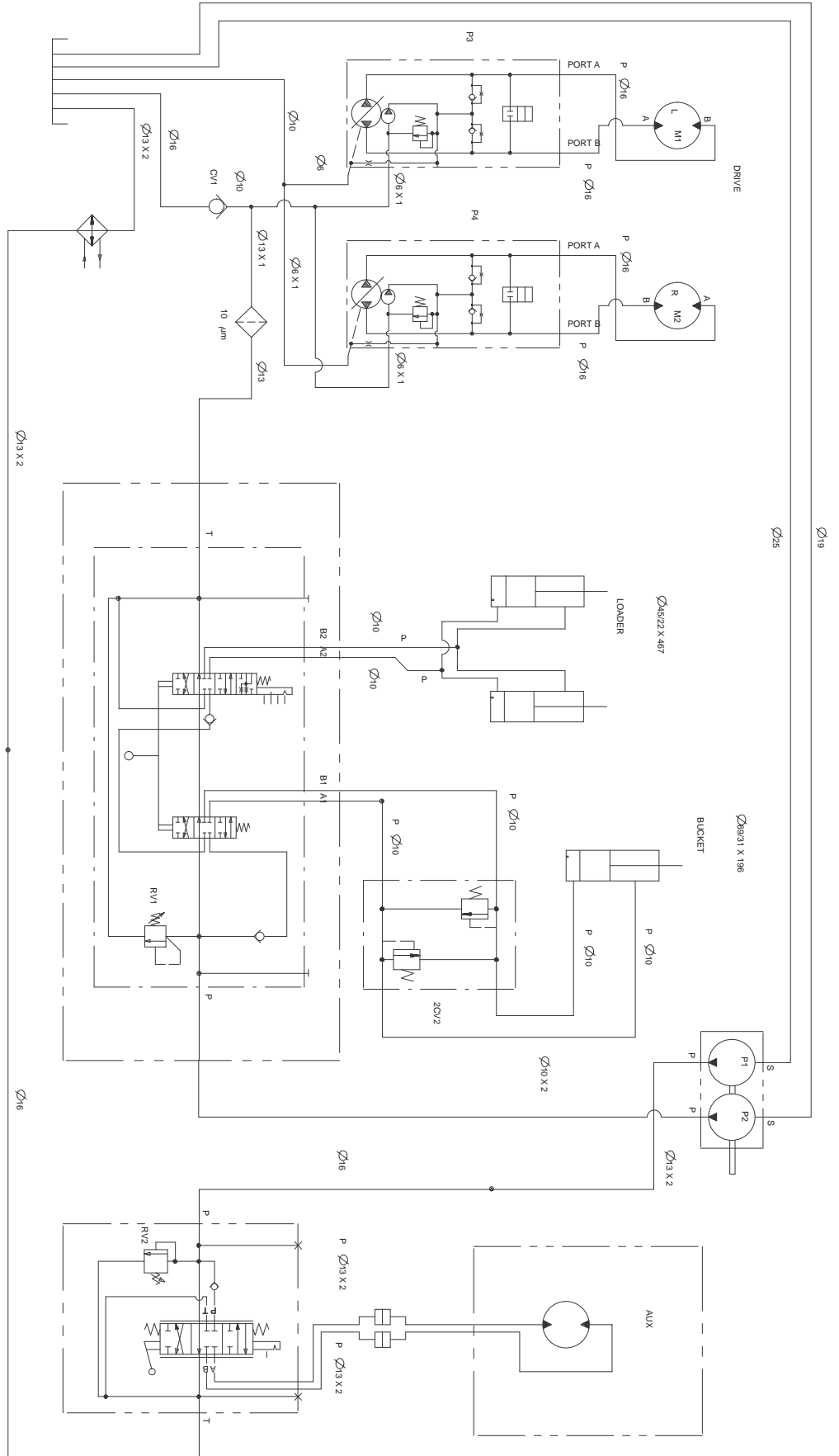

DISPLACEMENT A ND PRESSURE CHART

COMPONENT	DISPLACEMENT	DISPLACEMENT	PSI	BAR	FLOWRATE*	FLOWRATE*
COMPONENT	CU IN/REV	CU CM/REV	PSI	BAR	GPM	LPM
P1	0.73 CU IN	12 CC			11.2	42.4
P2	0.36 CU IN	6 CC			5.5	21.0
M1, M2	32.3 CU IN	528 CC				
P3, P4	0-1.28 CU IN	21 CC			17	64
RV1			2400 PSI	166 BAR		
RV2			3000 PSI	207 BAR		
CV1			5 PSI	35 BAR		
20VZ			3000 PSI	207 BAR		

\* FLOWRATE CALCULATED AT 3600 RPM A  
 \*\* FLOWRATE CALCULATED AT 3100 RPM A

ND 98% EFFICIENCY  
 ND 98% EFFICIENCY



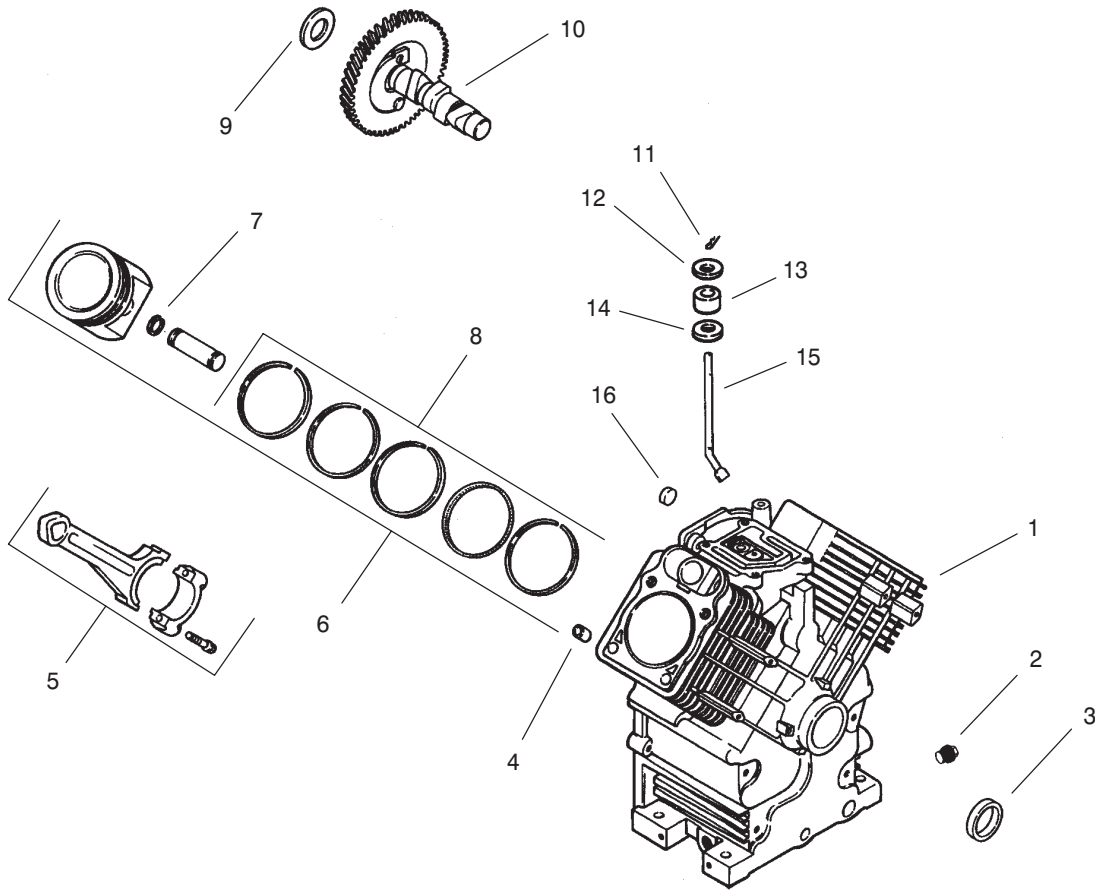

### Crankcase (CH20S 64656 Kohler)

Ref. No.	Part No.	Qty.	Description
1		1	Crankcase (Use Miniblock 24 782 15)
2	52 139 02-S	2	Plug, pipe
3	24 032 01-S	1	Seal, oil front
4	12 380 13-S	6	Pin, dowel locating
5	24 067 13-S	2	Connecting Rod (Std.)
	24 067 14-S	2	Connecting Rod (.25)
6	24 874 01-S	2	Piston w/Ring Set (Std.)
	24 874 02-S	2	Piston w/Ring Set (.25)
	24 874 03-S	2	Piston w/Ring Set (.50)
	24 874 14-S	2	Piston w/Ring Set (.08)
7	24 018 01-S	4	Retainer, piston pin
8	24 108 01-S	2	Ring Set (Std.)
	24 108 02-S	2	Ring Set (.25)
	24 108 03-S	2	Ring Set (.50)
9	12 422 09-S	A/R	Shim, camshaft - red
	12 422 13-S	A/R	Shim, camshaft - black
	12 422 07-S	A/R	Shim, camshaft - white
	12 422 08-S	A/R	Shim, camshaft - blue
	12 422 10-S	A/R	Shim, camshaft - yellow
	12 422 11-S	A/R	Shim, camshaft - green
	12 422 12-S	A/R	Shim, camshaft - gray
10	24 012 10-S	1	Camshaft

Ref. No.	Part No.	Qty.	Description
11	24 018 09-S	1	Retaining, Ring
12	M-931010-S	1	Washer, Nylon
13	28 032 09-S	1	Seal, governor cross shaft
14	24 468 15-S	1	Washer
15	24 144 33-S	1	Shaft, governor cross
16	52 139 09-S	1	Plug, cup

Obtain Parts From Kohler

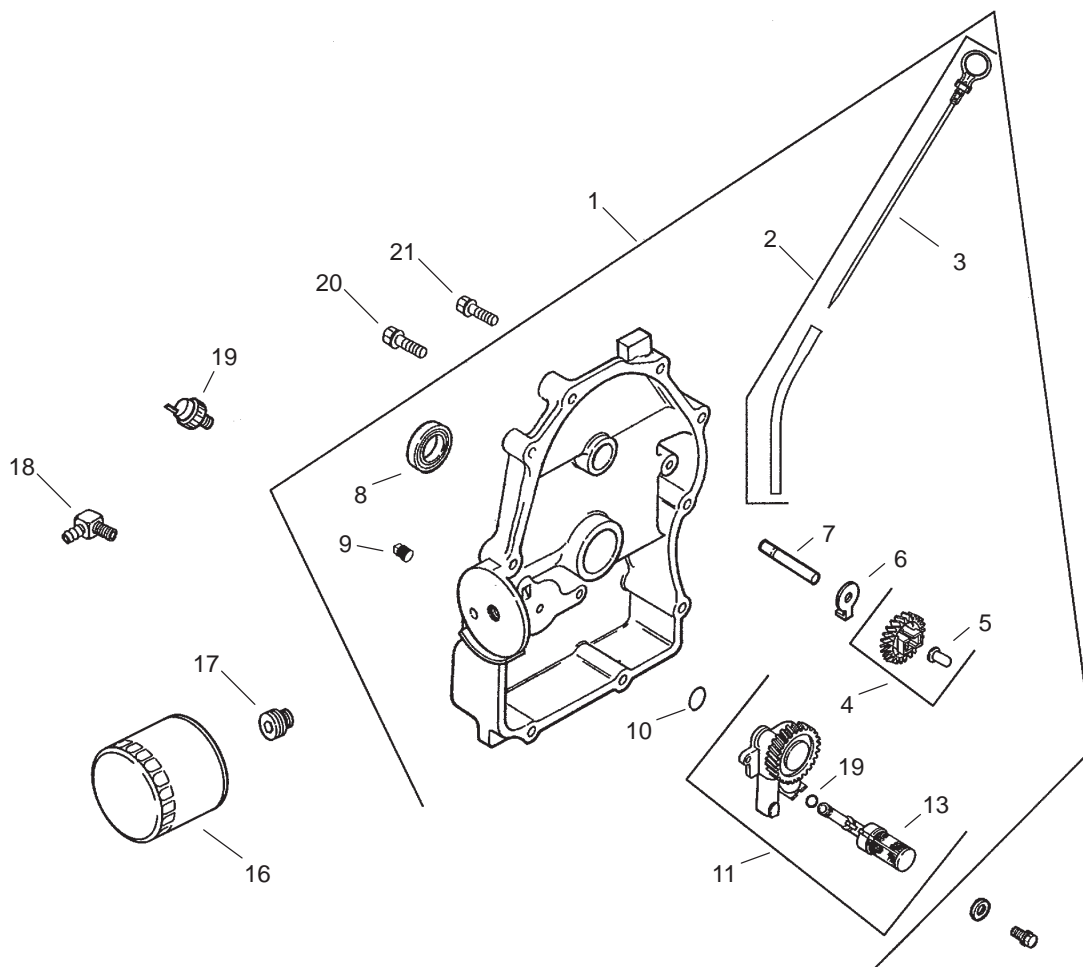

## Oil Pan/Lubrication (CH20S 64656 Kohler)

Ref. No.	Part No.	Qty.	Description	Ref. No.	Part No.	Qty.	Description
1	24 009 92-S	1	Plate, Closure ASM (Includes 2-13)				
2	24 755 121-S	1	Dipstick & Tube Kit (Includes 3)				
3	24 038 10-S	1	Dipstick				
4	24 043 12-S	1	Kit, governor gear (Includes 5)				
5	12 380 01-S	1	Pin, governor regulating				
6	52 448 02-S	1	Tab, locking				
7	12 144 02-S	1	Shaft, governor gear				
8	52 032 08-S	1	Seal, oil (PTO end)				
9	X-75-23-S	2	Plug, pipe 1/8"				
10	24 153 08-S	1	O-Ring				
11	24 393 10-S	1	Oil pump assembly (Includes 12,13)				
12	24 153 01-S	1	O-Ring, oil pick-up				
13	24 381 04-S	1	Pick-up, oil				
14	M-631005-S	2	Washer, plain 6 mm				
15	M-645025-S	2	Screw, hex flange				
16	52 050 02-S	1	Filter, oil				
17	24 136 01-S	1	Nipple, oil filter				
18	25 155 02-S	1	Connector				
19	24 099 03-S	1	Switch, pressure				
20	24 086 16-S	9	Screw, hex flange				
21	24 086 17-S	1	Screw, hex flange				

Obtain Parts From Kohler

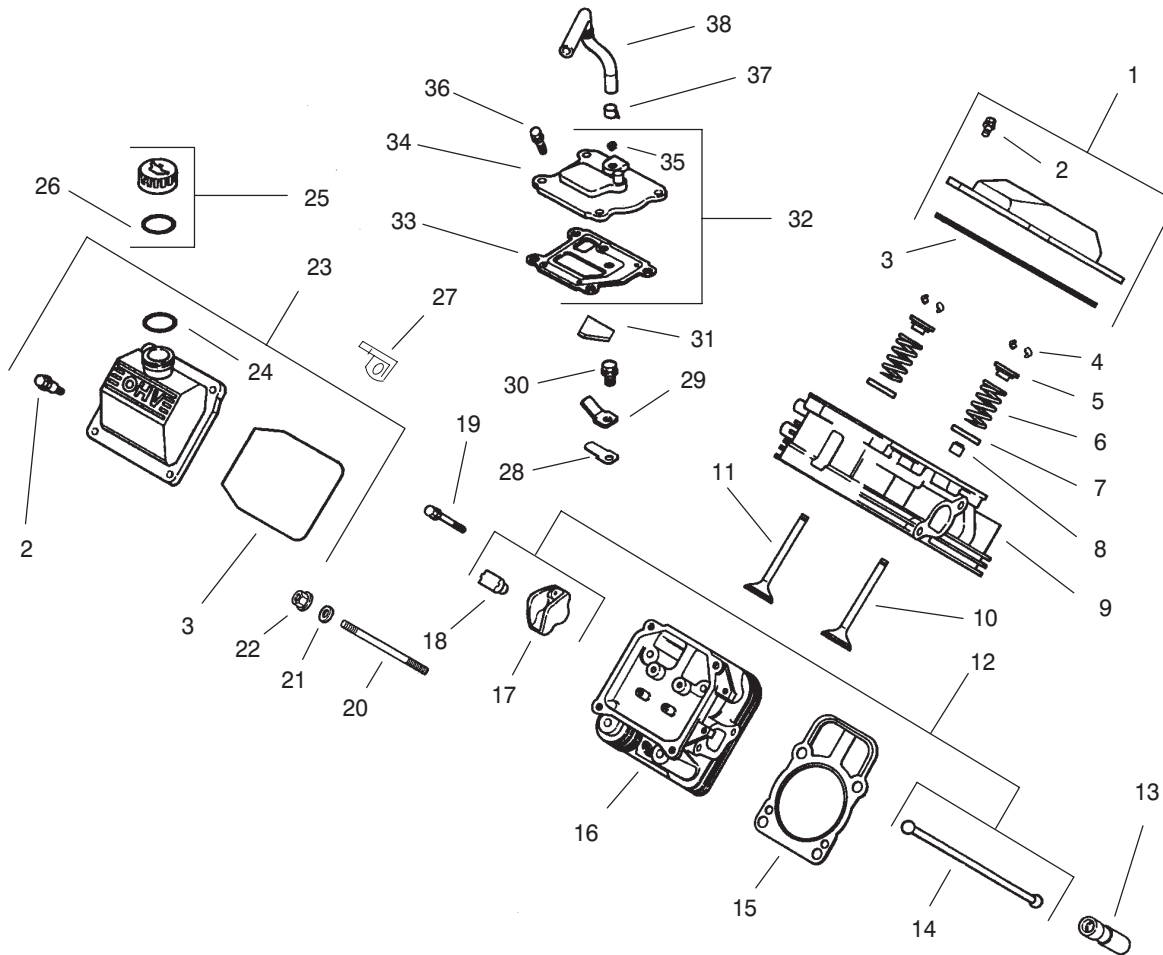

## Head/Valve/Breather (CH20S 64656 Kohler)

Ref. No.	Part No.	Qty.	Description
1	24 755 74-S	1	Kit, valve cover – plain (Includes 2-3)
2	24 086 32-S	4	Screw, shoulder
3	24 153 16-S	1	O-Ring, valve cover
4	12 755 03-S	4	Kit, retainer
5	12 173 01-S	4	Cap, valve spring
6	24 089 02-S	4	Spring, valve
7	235011-S	4	Retainer, spring
8	24 032 05-S	2	Seal, valve stem
9	24 318 68-S	1	Head assembly, #1 cylinder
10	24 017 01-S	2	Valve, intake ( Std.)
	24 017 02-S	2	Valve, intake (.25)
11	24 016 01-S	2	Valve, exhaust (Std.)
	24 016 02-S	2	Valve, exhaust (.25)
12	24 755 66-S	1	Kit, valve train (Includes 15,18,19)
13	12 351 01-S	4	Lifter, valve
14	24 411 05-S	4	Rod, push
15	24 041 08-S	2	Gasket, cylinder head
16	24 318 71-S	1	Head assembly, #2 cylinder
17	25 186 01-S	4	Arm, rocker
18	24 599 01-S	4	Pivot, rocker arm
19	M-640034-S	4	Screw, hex. flange
20	24 072 09-S	1	Stud, Cyl. Head

Ref. No.	Part No.	Qty.	Description
21	24 468 16-S	1	Washer, Flat
22	24 100 10-S	1	Nut-HF
23	24 755 75-S	1	Kit, valve cover – oil fill (Includes 2,3,23)
24	24 153 09-S	1	O-Ring
25	24 755 46-S	1	Kit, oil fill cap (Includes 24)
26	12 153 03-S	1	O-Ring, oil fill cap
27	24 445 01-S	1	Strap, Lifting
28	24 402 03-S	1	Reed, breather
29	12 018 01-S	1	Retainer, breather reed
30	M-545010-S	1	Screw, hex. flange
31	24 050 01-S	1	Filter, breather
32	24 033 01-S	1	Kit, breather (Includes 33-35)
33	24 041 23-S	1	Gasket, breather
34	24 096 58-S	1	Cover, breather
35	X-75-23-S	1	Plug, allen head pipe
36	M-645020-S	4	Screw, hex. flange
37	X-426-9-S	1	Clamp, breather
38	24 326 26-S	1	Hose, breather

Obtain Parts From Kohler

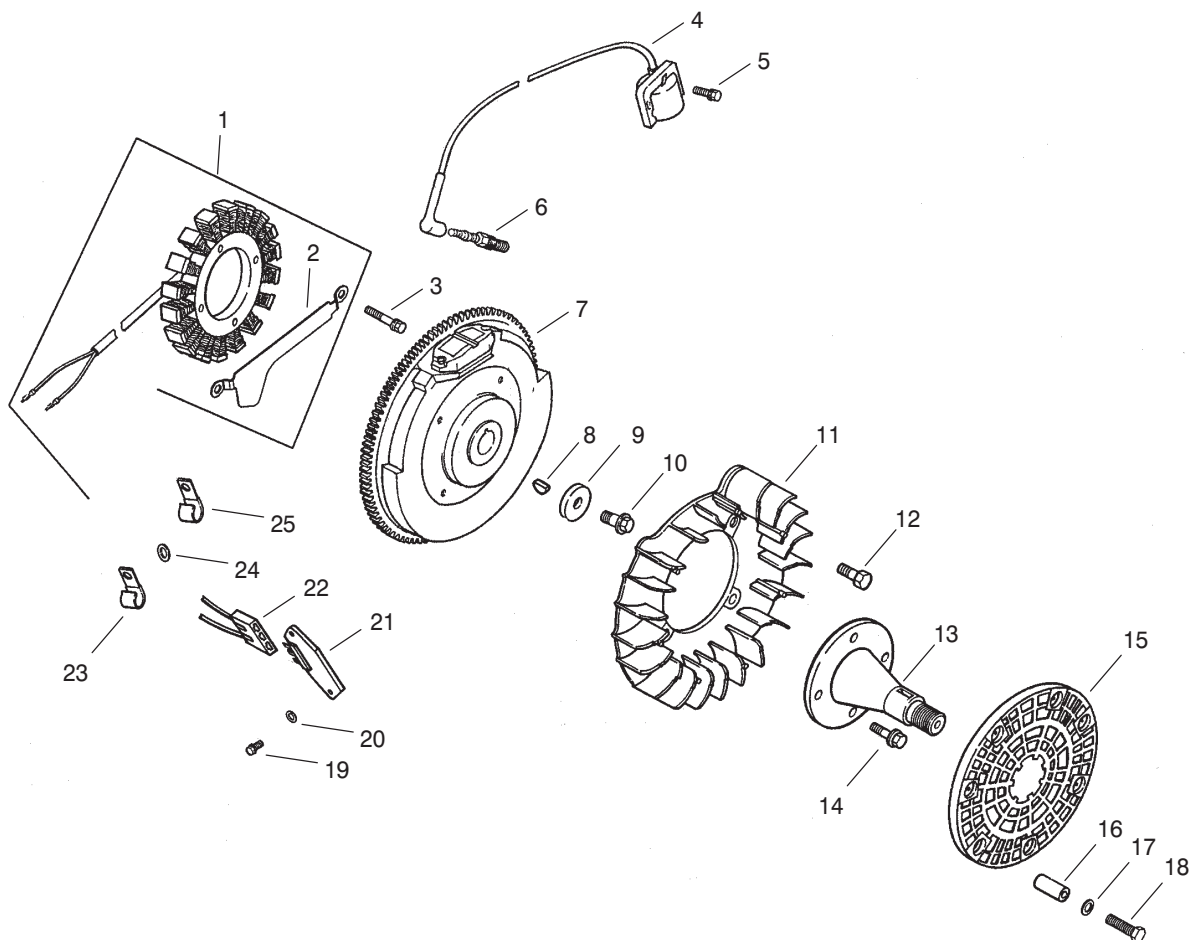

## Ignition/Electrical (CH20S 64656 Kohler)

Ref. No.	Part No.	Qty.	Description	Ref. No.	Part No.	Qty.	Description
1	54 755 09-S	1	Kit, 15 amp stator (Includes 2)	25	48 154 02-S	1	Clip, cable
2	24 126 71-S	1	Bracket, stator wire				<b>Not Illustrated</b>
3	M-548025-S	2	Screw, hex. cap	25 518 12-S	1	Lead, black, (4" - 18 gauge - insulated grip barrel eyelet terminals)	
4	24 584 01-S	2	Module, ignition	25 086 91-S	1	Screw, sems hex cap (used to mount terminal on wiring harness to baffle	
5	M-545020-S	4	Screw, hex. flange	24 176 08-S	1	Harness, wiring	
6	12 132 06-S	2	Spark Plug	X-22-11-S	1	Washer, lock	
7	24 025 01-S	1	Flywheel	25 454 03-S	2	Tie, cable	
8	X-42-15-S	1	Key				
9	12 468 03-S	1	Washer, plain 3/8"				
10	12 086 14-S	1	Screw, hex flange				
11	24 157 03-S	1	Fan				
12	25 086 47-S	4	Bolt, shoulder				
13	24 144 13-S	1	Shaft, front drive				
14	M-839025-S	4	Screw, hex flange				
15	24 162 18-S	1	Screen, grass				
16	24 122 04-S	4	Spacer				
17	X-25-92-S	2	Washer, plain 3/16				
18	M-403025-S	4	Screw				
19	24 086 18-S	2	Screw, phillips hd.				
20	X-25-92-S	2	Washer				
21	25 403 03-S	1	Rectifier-regulator 15 amp				
22	236602-S	1	Connector				
23	235173-S	1	Clip, cable				
24	X-25-63-S	1	Washer, plain 1/4"				

Obtain Parts From Kohler







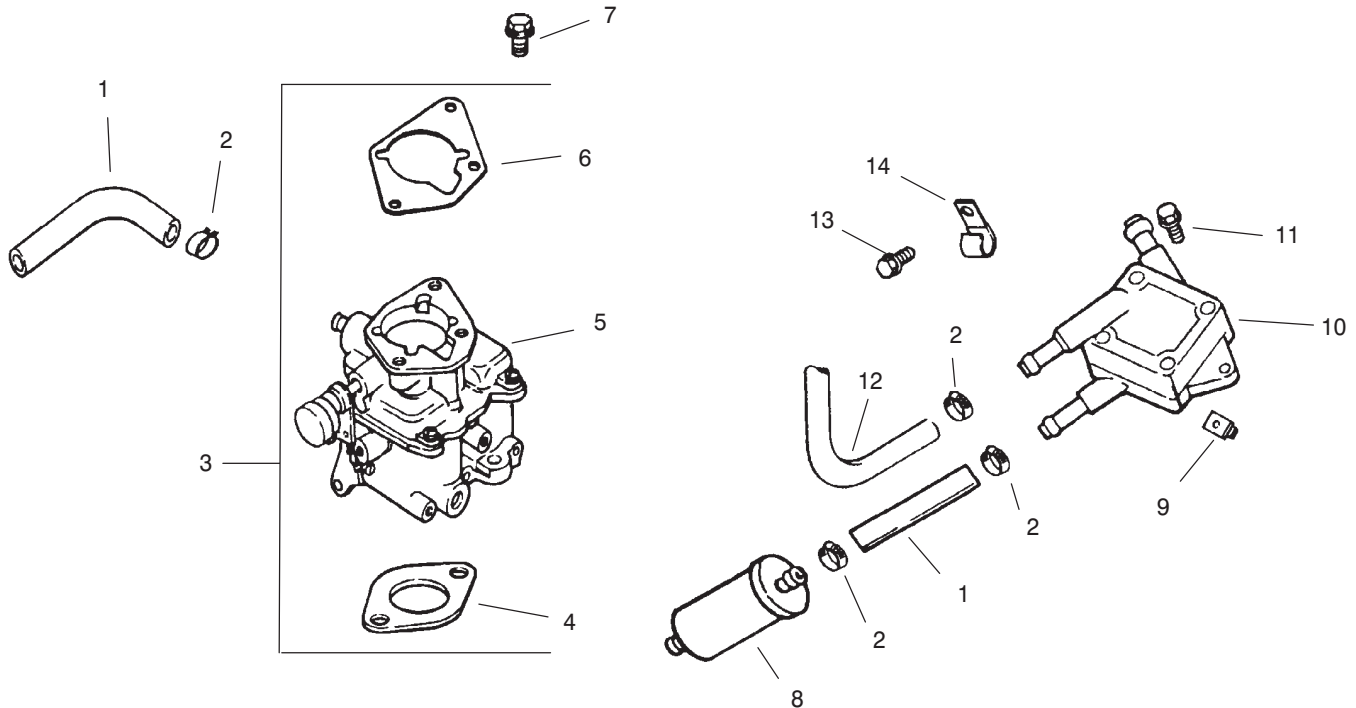

### Fuel System (CH20S 64656 Kohler)

Ref. No.	Part No.	Qty.	Description
1	25 353 32-S	2	Line, fuel - 9"
2	25 237 14-S	6	Clamp, hose
3	24 853 32-S	1	Kit, carburetor w/gasket (Incl. 4-6)
4	24 041 06-S	1	Gasket, air cleaner
5	24 053 32-S	1	Carburetor assembly (For information only not available separate Includes 24 757 01-S, 24 757 02-S, 24 757 03S & 24 757 07-S)
6	24 041 17-S	1	Gasket, carburetor
7	M-651030-S	2	Screw, hex. flange
8	24 050 02-S	1	Filter, fuel
9	24 100 01-S	2	Nut, plastic
10	24 393 16-S	1	Pump, fuel-pulse
11	24 086 12-S	2	Screw, hex cap
12	24 353 02-S	1	Line, fuel 15-1/2"
13	M-650012-S	1	Screw, hex flange
14	47 154 01-S	1	Clip, cable
	24 757 01-S	1	<b>Not Illustrated</b> Kit, solenoid (Includes solenoid 24 521 01-S, O-Ring 24 153 04-S, O-Ring 24 153 05-S, O-Ring 24 153 06-S,

Ref. No.	Part No.	Qty.	Description
			Solenoid screw 24 086 07-S, & Solenoid 24 435 01-S)
	24 757 02-S	1	Kit-Float
	24 757 07-S	1	Kit, choke (Includes choke lever cap 24 173 02-S)
	24 757 03-S	1	Kit, carburetor repair (Includes inlet needle valve clip 24 154 01-S, inlet needle valve 24 462 01-S, carburetor body screw 24 086 09-S, carburetor body gasket 24 041 09-S, slow O-Ring 24 153 02-S, O-Ring 24 13 04-S, O-Ring 24 153 05-S, O-Ring 24 153 06-S, idle needle 24 368 01-S, & idle needle spring 24 089 11-S)

Obtain Parts From Kohler

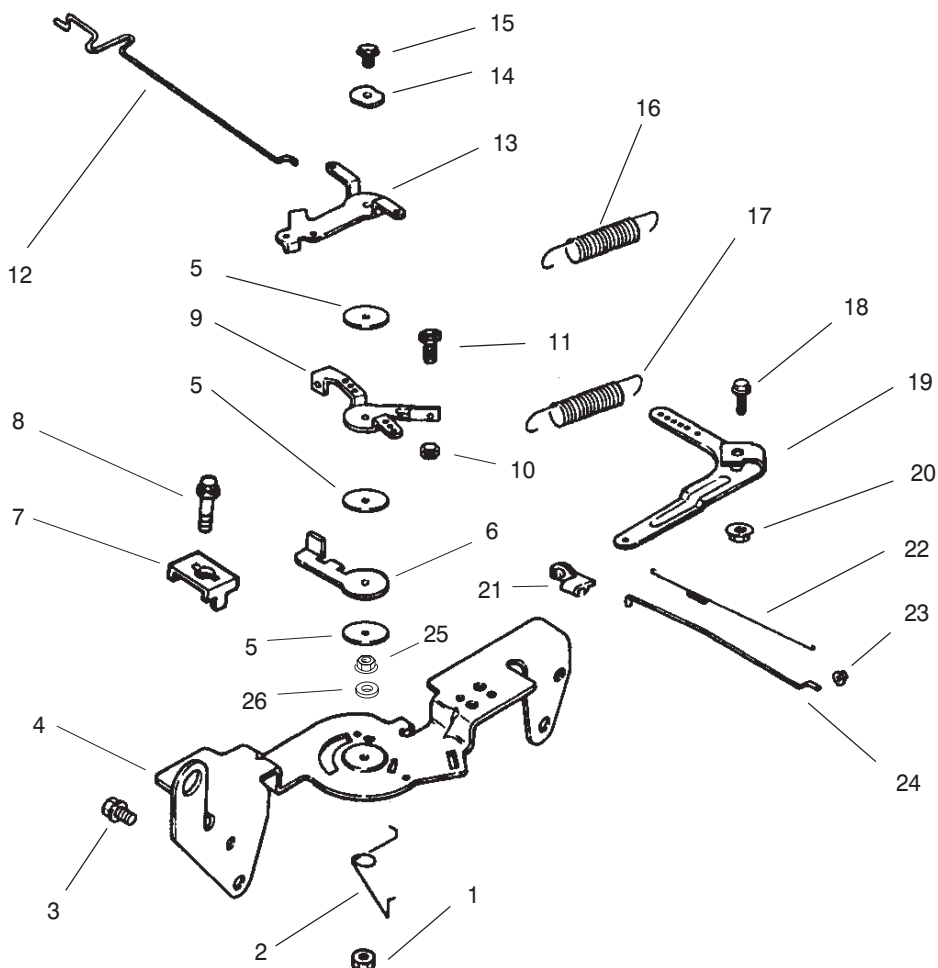

## Engine Control (CH20S 64656 Kohler)

Ref. No.	Part No.	Qty.	Description
1	M-547050-S	1	Nut, hex. lock
2	24 089 03-S	1	Spring, choke return
3	M-645016-S	4	Screw, hex. flange
4	24 126 56-S	1	Bracket, control
5	24 468 01-S	3	Washer, plain
6	24 090 07-S	1	Lever, throttle actuator
7	12 237 01-S	2	Clamp, cable
8	M-545016-S	2	Screw, hex. flange
9	24 090 03-S	1	Lever, throttle control
10	M-446030-S	1	Nut, hex
11	M-401030-S	1	Screw, hex. cap
12	24 079 02-S	1	Linkage, choke
13	24 090 05-S	1	Lever, choke
14	41 468 03-S	1	Washer, spring
15	M-545020-S	1	Screw, hex. flange
16	24 089 51-S	1	Spring, throttle limiter
17	24 089 46-S	1	Spring, governor
18	24 211 03-S	1	Screw, hex. flange
19	24 090 33-S	1	Lever, governor
20	M-641060-S	1	Nut, hex. flange
21	25 158 11-S	1	Bushing, linkage retaining
22	24 089 01-S	1	Spring, linkage
23	25 158 08-S	1	Bushing, linkage retaining
24	24 079 01-S	1	Linkage, throttle

Ref. No.	Part No.	Qty.	Description
25	M-545010-S	1	Nut-HF
26	X-20-1-S	1	Washer, Lock

Obtain Parts From Kohler



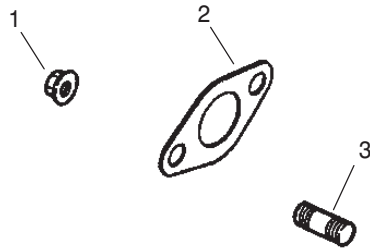

### Exhaust (CH20S 64656 Kohler)

Ref. No.	Part No.	Qty.	Description
1	M-841080-S	4	Nut, hex flange
2	24 041 02-S	2	Gasket, exhaust
3	25 072 04-S	4	Stud
			<b>Not Illustrated</b>
	24 782 15	1	Miniblock
	24 755 107-S	1	Gasket Set

Ref. No.	Part No.	Qty.	Description

Obtain Parts From Kohler





