



Count on it.

Operator's Manual

Greensmaster® Flex™ 1018 or 1021 Traction Unit

Model No. 04850—Serial No. 408000000 and Up

Model No. 04860—Serial No. 408000000 and Up

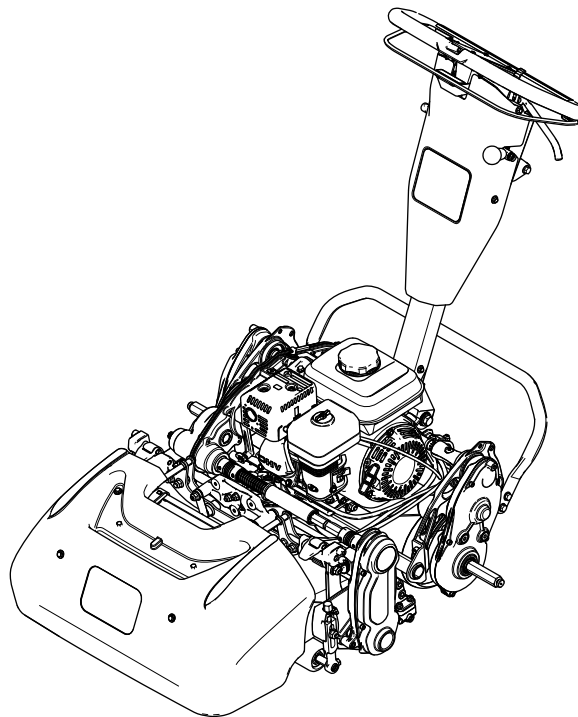

information and **Note** emphasizes general information worthy of special attention.

Contents

Safety	4	Servicing the Spark Plug.....	25
General Safety.....	4	Controls System Maintenance	26
Safety and Instructional Decals	4	Adjusting the Traction Cable	26
Setup	6	Adjusting the Service/Parking Brake.....	27
1 Adjusting and Installing the Cutting		Adjusting the Reel-Control Cable.....	28
Unit	6	Adjusting the Throttle Cable.....	28
2 Installing the Transport Wheels.....	6	Tightening the Handle-Isolation	
3 Installing the Grass Basket	7	Hardware	30
4 Adjusting the Engine Speed	7	Cutting Unit Maintenance	30
5 Acknowledging the Traction-Drum		Blade Safety	30
Position.....	8	Installing the Cutting Unit.....	30
Product Overview	9	Removing the Cutting Unit.....	31
Controls	10	Backlapping the Cutting Unit.....	32
Specifications	12	Storage	32
Attachments/Accessories.....	12	Storage Safety.....	32
Before Operation	13	Storing the Machine.....	32
Before Operation Safety	13		
Performing Daily Maintenance.....	13		
Checking the Engine-Oil Level.....	13		
Fuel Specifications	13		
Filling the Fuel Tank.....	14		
Adjusting the Clip Rate	14		
Adjusting the Reel Speed	14		
Adjusting the Handle Height	15		
Transporting the Machine to a Job			
Site.....	15		
Removing the Transport Wheels.....	15		
Using the Choke Lever	16		
Opening and Closing the Fuel-Shutoff			
Valve	16		
During Operation	17		
During Operation Safety	17		
Starting the Engine	18		
Operating Tips	18		
Shutting Off the Engine.....	19		
After Operation	19		
After Operation Safety	19		
Operating the Controls after Mowing.....	19		
Transporting the Machine	19		
Installing the Transport Wheels.....	20		
Engaging or Disengaging the			
Transmission	20		
Maintenance	21		
Maintenance Safety.....	21		
Recommended Maintenance Schedule(s)	21		
Daily Maintenance Checklist.....	22		
Pre-Maintenance Procedures	23		
Preparing the Machine for Maintenance.....	23		
Engine Maintenance	23		
Engine Safety	23		
Servicing the Engine Oil.....	23		
Servicing the Air Cleaner	24		

Safety

This machine has been designed in accordance with EN ISO 5395 and ANSI B71.4-2017.

General Safety

This product is capable of amputating hands and feet and of throwing objects.

- Read and understand the contents of this *Operator's Manual* before starting the machine.
- Use your full attention while operating the machine. Do not engage in any activity that causes distractions; otherwise, injury or property damage may occur.
- Do not put your hands or feet near moving components of the machine.

- Do not operate the machine without all guards and other safety protective devices in place and functioning properly on the machine.
- Keep bystanders and children out of the operating area. Never allow children to operate the machine.
- Shut off the engine, remove the key (if equipped), and wait for all movement to stop before you leave the operator's position. Allow the machine to cool before adjusting, servicing, cleaning, or storing it.

Improperly using or maintaining this machine can result in injury. To reduce the potential for injury, comply with these safety instructions and always pay attention to the safety-alert symbol **▲**, which means Caution, Warning, or Danger—personal safety instruction. Failure to comply with these instructions may result in personal injury or death.

Safety and Instructional Decals



Safety decals and instructions are easily visible to the operator and are located near any area of potential danger. Replace any decal that is damaged or missing.



120-9570

decal120-9570

1. Warning—stay away from moving parts, keep all guards and shields in place.



133-8062

decal133-8062

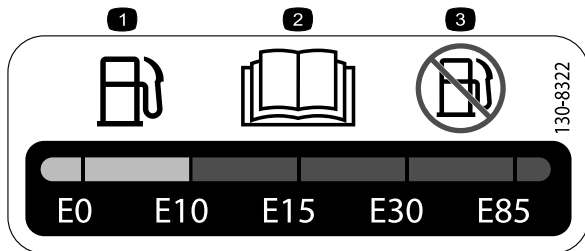

130-8322

decal130-8322

1. Use only fuel with an alcohol content by volume under 10%.
2. Read the *Operator's Manual* for more information on fuel.
3. Do not use fuel with an alcohol content by volume greater than 10%.

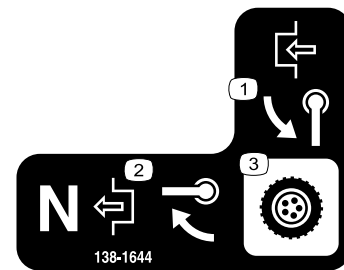

138-1644

decal138-1644

1. Rotate the handle to engage.
2. With the machine in the Neutral position, rotate the handle to disengage.
3. Transmission control



138-1589

decal138-1589

1. Engage the reels.
2. Disengage the reels.

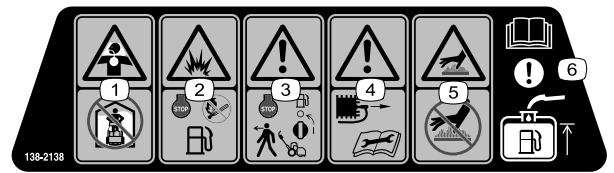

138-2138

decal138-2138

1. Poisonous fumes or toxic gases, asphyxiation hazard—do not run the engine in an enclosed space.
2. Explosion hazard—shut off the engine before adding fuel; no fire, open flames, or smoking when adding fuel.
3. Warning—shut off the engine and close the fuel shutoff valve before leaving the machine.
4. Warning—disconnect the spark plug wire before performing maintenance.
5. Hot surface hazard—do not touch the hot surface.
6. Attention—read the *Operator's Manual* for information about filling the fuel tank.

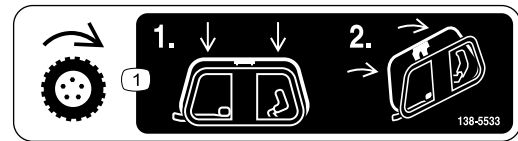

138-5533

decal138-5533

1. Traction control—press the traction control down then pull it to the handle.

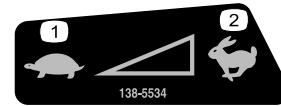

138-5534

decal138-5534

1. Slow
2. Fast



138-5532

decal138-5532

1. Pull up to release the brake.
2. Pull down to apply the brake.
3. Parking brake—locked
4. Parking brake—unlocked
5. Warning—read the *Operator's Manual*.
6. Warning—do not operate this machine unless you are trained.
7. Warning—wear hearing protection.
8. Thrown object hazard—keep bystanders away.
9. Warning—stay away from moving parts; keep all guards and shields in place.
10. Do not tow the machine.

Setup

Loose Parts

Use the chart below to verify that all parts have been shipped.

Procedure	Description	Qty.	Use
1	Cutting unit (order separately; contact your authorized Toro distributor)	1	Adjust and install the cutting unit to the machine.
	Hex tube	1	
	Spring	1	
	Collar	1	
2	Transport Wheel Kit (order separately; contact your authorized Toro distributor)	1	Install the transport wheels (optional).
3	Grass basket	1	Install the grass basket.
4	CE decal	1	Adjust the engine speed (for use in CE-compliant countries only).
5	No parts required	–	Acknowledge the traction-drum position.

Media and Additional Parts

Description	Qty.	Use
Operator's Manual	1	Read or view the items before operating the machine.
Engine Owner's Manual	1	
Certificate of Compliance	1	

Note: Determine the left and right sides of the machine from the normal operating position.

1

Adjusting and Installing the Cutting Unit

Parts needed for this procedure:

1	Cutting unit (order separately; contact your authorized Toro distributor)
1	Hex tube
1	Spring
1	Collar

Procedure

- Adjust the cutting unit to your desired settings; refer to the cutting unit *Operator's Manual*.
- Install the spring, collar, and hex tube to the transmission coupler shaft ([Figure 3](#)).
- Install the cutting unit to the machine; refer to [Installing the Cutting Unit \(page 30\)](#).

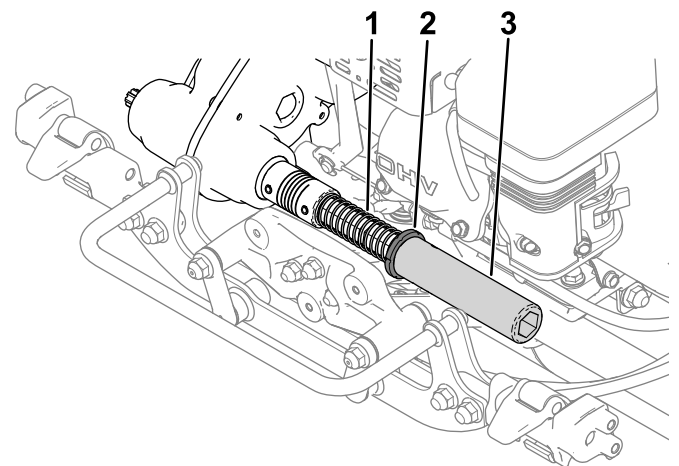

Figure 3

- Spring
- Collar
- Hex tube

g307641

2

Installing the Transport Wheels

Optional

Parts needed for this procedure:

1	Transport Wheel Kit (order separately; contact your authorized Toro distributor)
---	--

Procedure

To install the transport wheels, you must first acquire the Transport Wheel Kit (Model 04123). Contact your authorized Toro distributor for this kit.

1. Install the transport wheels; refer to [Installing the Transport Wheels \(page 20\)](#).
2. Ensure that the tires are inflated to 83 to 103 kPa (12 to 15 psi).

3

Installing the Grass Basket

Parts needed for this procedure:

1	Grass basket
---	--------------

Procedure

1. Grasp the basket by the handle.
2. Guide the basket lip between the cutting unit side plates and over the front roller ([Figure 4](#)).

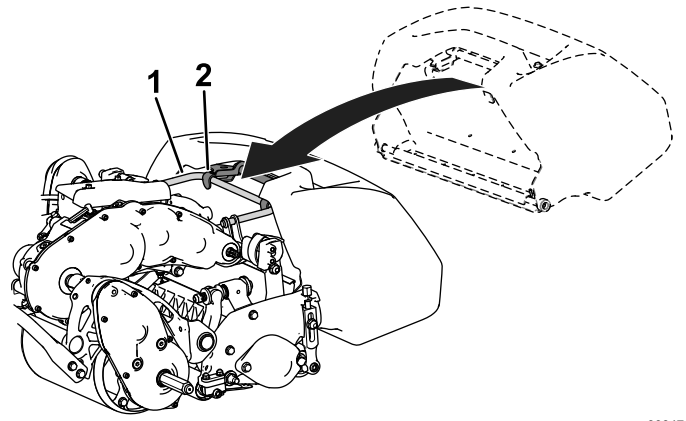

g308471

Figure 4

1. Frame loop
2. Basket hooks

3. Install the basket hooks over the frame loop ([Figure 4](#)).

Important: If you drop the basket, examine the pitch-arm contact points near the lower lip of the basket for damage ([Figure 5](#)). Straighten them before using the basket.

Using the basket with bent pitch-arm contact points may cause contact between the basket and cutting unit, causing undesired noise and/or damage to the basket and cutting unit.

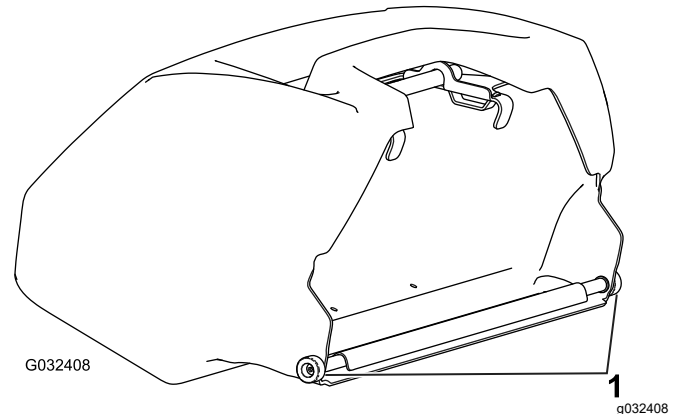

G032408

g032408

Figure 5

1. Pitch-arm contact point

4

Adjusting the Engine Speed For CE-Compliant Countries Only

Parts needed for this procedure:

1	CE decal
---	----------

Procedure

If you use your machine in a country that complies to CE standards, meet noise regulations by adjusting the high-idle engine speed and installing the CE decal:

- Adjust the high-idle engine speed to the following specifications:
 - 1018 machines: **3,000 rpm**
 - 1021 and 1026 machines: **3,150 rpm**

Refer to [Adjusting the High-Idle Engine Speed \(page 29\)](#).

- Install the CE decal below the serial plate ([Figure 6](#)).

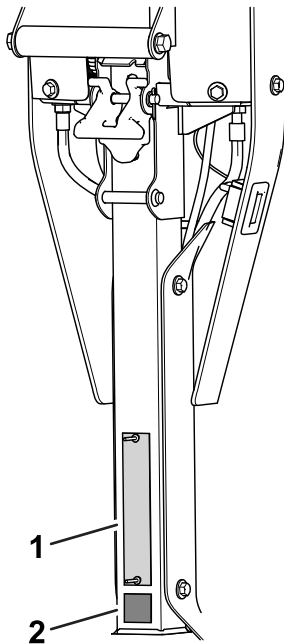

Figure 6

g372646

1. Serial plate

2. CE decal

5

Acknowledging the Traction-Drum Position

No Parts Required

Procedure

The traction-drum position can be adjusted to a Low or HIGH height-of-cut position.

The traction-drum default position is Low ([Figure 7](#)). Do not adjust the drum to the HIGH position; this position negatively affects the quality of cut.

Product Overview

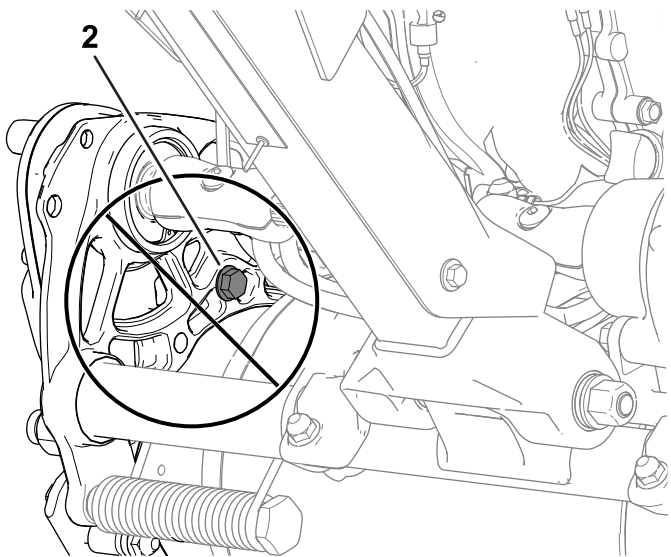
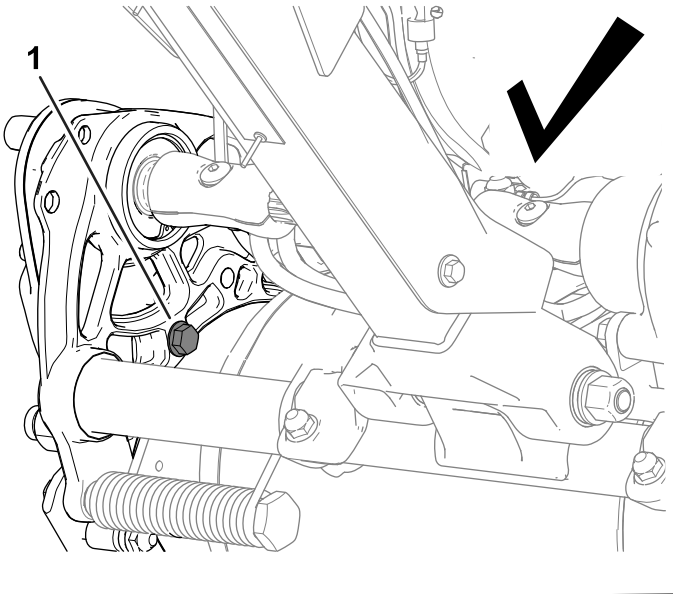

Figure 7

- 1. Low position
- 2. HIGH position

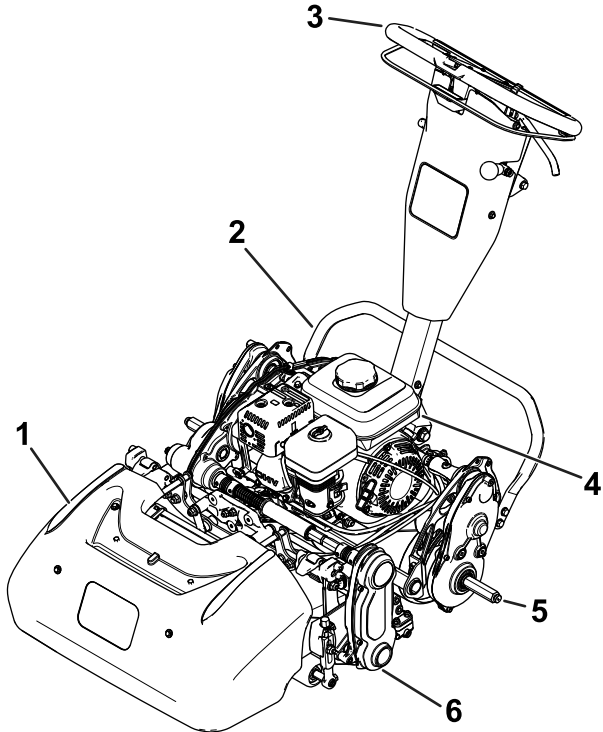

Figure 8

- 1. Grass basket
- 2. Kickstand
- 3. Handle
- 4. Fuel tank
- 5. Transport-wheel axle
- 6. Cutting unit

g310034

g316029

Controls

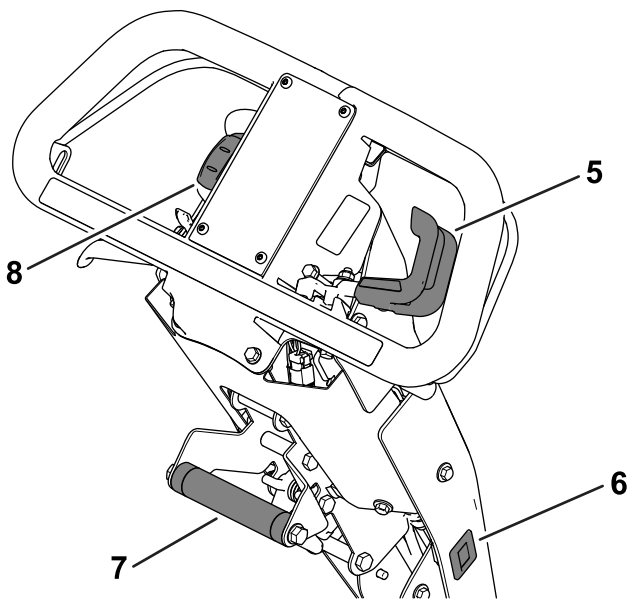
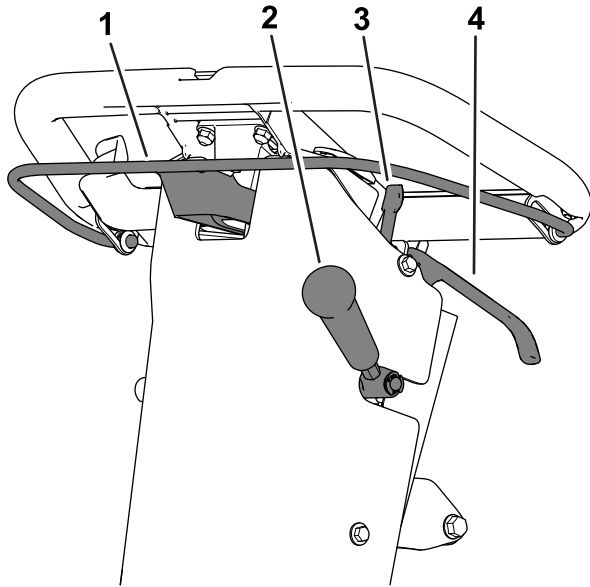

Figure 9

g271082

- | | |
|-----------------------------|-----------------------|
| 1. Clutch bail | 5. Throttle control |
| 2. Cutting-unit-drive lever | 6. Hour meter |
| 3. Parking-brake latch | 7. Lift-assist handle |
| 4. Service-brake lever | 8. On/Off switch |

Clutch Bail

Use the clutch bail (Figure 9) to engage or disengage the traction drive.

- **Engage the traction drive:** Pull up and hold the bar to the handle.
- **Disengage the traction drive:** Release the bar.

Throttle Control

Use the throttle control (Figure 9) to adjust the engine speed.

- **Increase the engine speed:** Rotate the lever down.
- **Decrease the engine speed:** Rotate the lever up.

On/Off Switch

The switch (Figure 9) allows you to start or shut off the engine.

- **Start the engine:** Push down on the upper part of the switch.
- **Shut off the engine:** Push down on the lower part of the switch.

Service-Brake Lever

Use the service brake (Figure 9) to slow or stop the machine. Pull the lever toward the handle to engage the service brake.

Parking-Brake Latch

Use the parking-brake latch (Figure 9) to engage the parking brake while you are away from the machine.

- **Engage the parking brake:** Engage and hold the service-brake lever and rotate the parking-brake latch toward you.
- **Disengage the parking brake:** Pull the service-brake lever toward the handle.

Cutting-Unit-Drive Lever

Use the cutting-unit-drive lever (Figure 9) to engage or disengage the cutting unit while the clutch bail is engaged.

- **Engage the cutting unit:** Move the lever down.
- **Disengage the cutting unit:** Move the lever up.

Hour Meter

The hour meter (Figure 9) records the total number of hours that the engine has been running. Refer to the meter for scheduling regular maintenance.

Lift-Assist Handle

Use the lift-assist handle (Figure 9) to help with adjusting the handle height or raise and lower the kickstand.

Handle-Height Adjuster

Use the handle-height adjuster (Figure 10) to move the handle height to a comfortable operating position. Pull up on the adjuster and use the lift-assist handle to raise or lower the handle height.

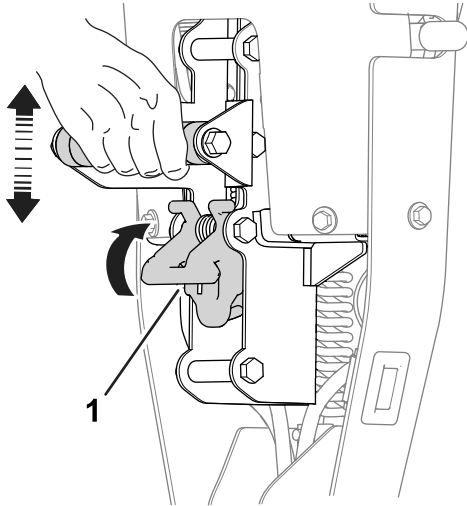

Figure 10

g271081

1. Handle-height adjuster

Choke Lever

The choke lever (Figure 11) is located on the left front of the engine. Use the lever to aid in starting a cold engine; refer to Using the Choke Lever (page 16).

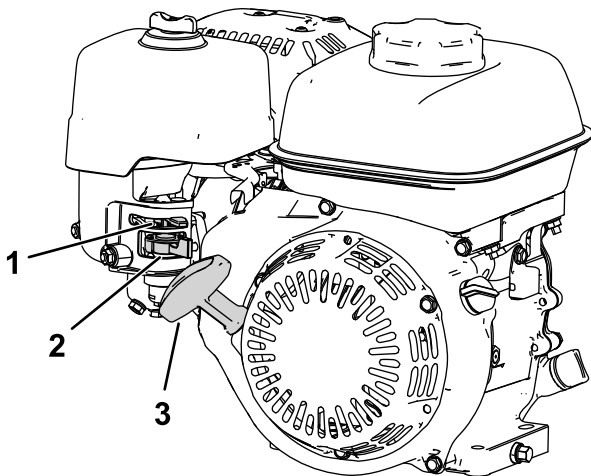

Figure 11

g265059

1. Choke lever
2. Fuel-shutoff valve
3. Recoil-starter handle

Fuel-Shutoff Valve

The fuel-shut-off valve is located on the side of the engine below the choke control (Figure 11).

Note: Close the fuel-shutoff valve when the machine is not used for a few days, during transport to and from the job site, or when the machine is parked inside a building; refer to [Opening and Closing the Fuel-Shutoff Valve](#) (page 16).

Recoil-Starter Handle

Pull the recoil-starter handle (Figure 11) to start the engine.

Kickstand

The kickstand (Figure 12) is mounted to the rear of the machine. Use the kickstand when you install or remove the transport wheels or the cutting unit.

• TRANSPORT-WHEEL-SERVICE position:

To use the kickstand to install the transport wheels, put your foot on the kickstand while pulling up and back on the lift-assist handle (Figure 12).

⚠ CAUTION

The machine is heavy and can cause back strain if lifted improperly.

Put your foot pressure down on the kickstand and use only the lift-assist handle to raise the machine. Attempting to raise the machine onto the kickstand any other way can cause injury.

• CUTTING-UNIT-SERVICE position:

To prevent the machine from tipping backward when removing the cutting unit, lower the kickstand and push out the spring pin so that it keeps the kickstand in the position shown in Figure 13.

• Retracting the kickstand to the STORAGE position:

1. Keep your foot on the kickstand while lowering the traction drum to the ground.
2. Remove your foot from the kickstand and allow space for the kickstand to retract to the STORAGE position.

Specifications

	Model 04850	Model 04860
Width	84 cm (33 inches)	91 cm (36 inches)
Dry weight*	84 kg (185 lb)	86 kg (190 lb)
Width of cut	46 cm (18 inches)	53 cm (21 inches)
Height of cut	Refer to your cutting unit <i>Operator's Manual</i> .	
Clip	Dependent on reel speed and reel-drive-pulley position; refer to Adjusting the Clip Rate (page 14) .	
Engine speed	Low idle: 1,900 ± 100 rpm; High idle: 3,450 ± 100 rpm	
Mowing speed	3.2 km/h (2 mph) to 5.6 km/h (3.5 mph)	
Transport speed	8.5 km/h (5.3 mph)	
*Traction unit only. Refer to the cutting unit <i>Operator's Manual</i> for the weight of each cutting unit.		

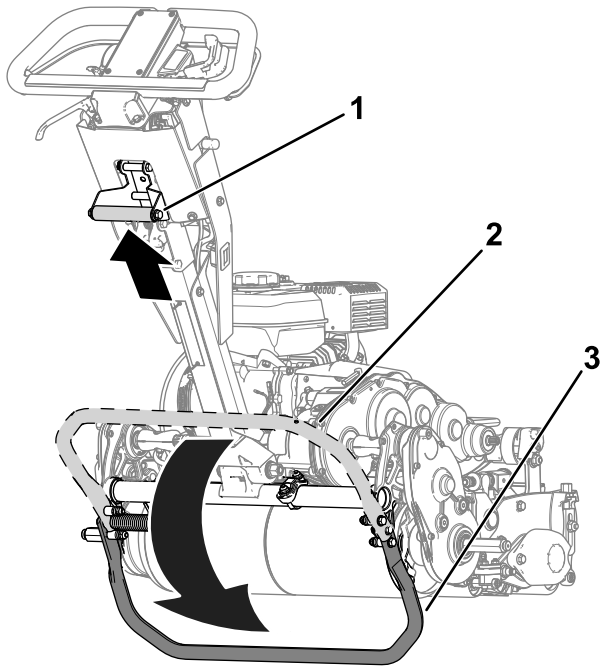

g310163

Figure 12

- 1. Lift-assist handle
- 2. Kickstand—STORAGE position
- 3. Kickstand—TRANSPORT-WHEEL SERVICE position

Attachments/Accessories

A selection of Toro approved attachments and accessories is available for use with the machine to enhance and expand its capabilities. Contact your Authorized Service Dealer or authorized Toro distributor or go to www.Toro.com for a list of all approved attachments and accessories.

To ensure optimum performance and continued safety certification of the machine, use only genuine Toro replacement parts and accessories. Replacement parts and accessories made by other manufacturers could be dangerous, and such use could void the product warranty.

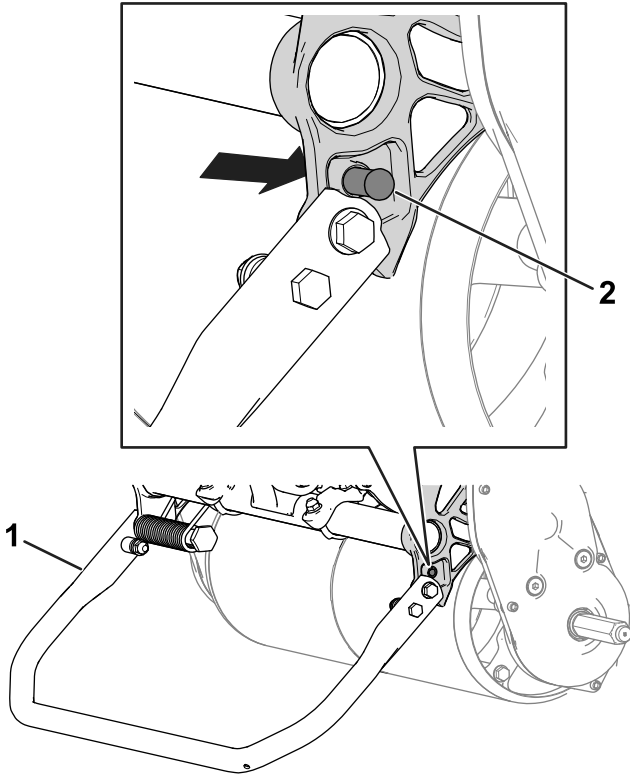

g341757

Figure 13

- 1. Kickstand—CUTTING-UNIT SERVICE position
- 2. Spring pin

Operation

Note: Determine the left and right sides of the machine from the normal operating position.

Before Operation

Before Operation Safety

General Safety

- Never allow children or untrained people to operate or service the machine. Local regulations may restrict the age of the operator. The owner is responsible for training all operators and mechanics.
- Become familiar with the safe operation of the equipment, operator controls, and safety signs.
- Shut off the machine, remove the key (if equipped), and wait for all movement to stop before you leave the operator's position. Allow the machine to cool before adjusting, servicing, cleaning, or storing it.
- Know how to stop the machine and shut off the machine quickly.
- Check that operator-presence controls, safety switches, and safety protective devices are attached and functioning properly. Do not operate the machine unless they are functioning properly.
- Inspect the area where you will use the machine and remove all objects that the machine could throw.

Fuel Safety

- Use extreme care in handling fuel. It is flammable and its vapors are explosive.
- Extinguish all cigarettes, cigars, pipes, and other sources of ignition.
- Use only an approved fuel container.
- Do not remove the fuel cap or add fuel to the tank while the engine is running or hot.
- Do not add or drain fuel in an enclosed space.
- Do not store the machine or fuel container where there is an open flame, spark, or pilot light, such as on a water heater or other appliance.
- If you spill fuel, do not attempt to start the engine; avoid creating a source of ignition until the fuel vapors have dissipated.
- Do not fill containers inside a vehicle or on a truck or trailer bed with a plastic liner. Always place

containers on the ground, away from the vehicle before filling.

- Remove equipment from the truck or trailer and refuel it on the ground. If this is not possible, refuel such equipment with a portable container rather than from a fuel-dispenser nozzle.
- Keep the nozzle in contact with the rim of the fuel tank or container operating at all times until fueling is complete.

Performing Daily Maintenance

Perform the daily maintenance procedures; refer to [Daily Maintenance Checklist \(page 22\)](#).

Checking the Engine-Oil Level

Check the engine-oil level before each use or every 8 operating hours, refer to [Checking the Engine-Oil Level \(page 23\)](#).

Fuel Specifications

Fuel tank capacity: 2.0 L (0.59 US gallons)

Recommended fuel: Unleaded gasoline with an octane rating of 87 or higher ((R+M)/2 rating method)

Ethanol: Gasoline with up to 10% ethanol (gasohol) or 15% MTBE (methyl tertiary butyl ether) by volume is acceptable. Ethanol and MTBE are not the same. Gasoline with 15% ethanol (E15) by volume is not approved for use.

- **Never use gasoline that contains more than 10% ethanol by volume**, such as E15 (contains 15% ethanol), E20 (contains 20% ethanol), or E85 (contains up to 85% ethanol).
- **Do not** use gasoline containing methanol.
- **Do not** store fuel either in the fuel tank or fuel containers over the winter unless you use a fuel stabilizer.
- **Do not** add oil to gasoline.
- For best results, use only clean, fresh (less than 30 days old) fuel.
- Using unapproved gasoline may cause performance problems and/or engine damage, which may not be covered under the warranty.

Filling the Fuel Tank

1. Clean around the fuel-tank cap and remove the cap from the tank (Figure 14). Fill the fuel tank to the bottom of the tank-neck opening; refer to your engine *Operator's Manual*.

Important: Do not overfill the tank with fuel.

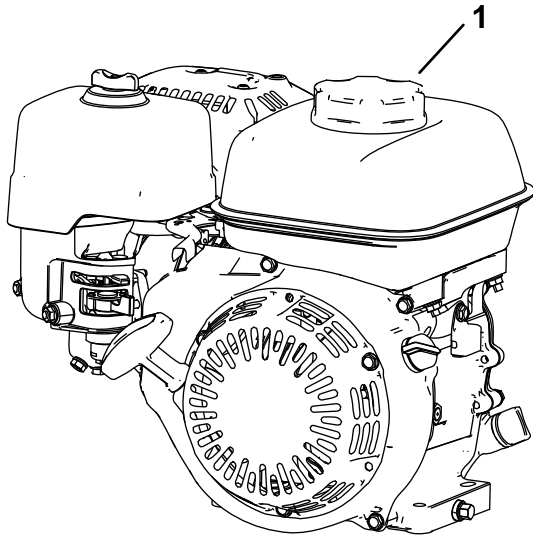

Figure 14

g265976

1. Fuel-tank cap

2. Install the fuel-tank cap and wipe up any spilled fuel.

Adjusting the Clip Rate

The clip rate is determined by the following machine settings:

- **Reel speed:** You can adjust the reel speed to a high or low setting; refer to [Adjusting the Reel Speed](#) (page 14).
- **Reel-drive-pulley position:** You can set the reel-drive pulleys in 2 positions; refer to your cutting unit *Operator's Manual*.

To determine the reel speed and reel-drive-pulley position for the appropriate clip, refer to the following table:

Clip Rate

Reel Speed	Belt Position	Cutting Unit		
		8-blade	11-blade	14-blade
Low	Low	7.3 mm (0.286 inch)	5.3 mm (0.208 inch)	4.2 mm (0.164 inch)
Low	High	8.7 mm (0.241 inch)	4.4 mm (0.175 inch)	3.5 mm (0.137 inch)
High	Low	5.9 mm (0.233 inch)	4.3 mm (0.169 inch)	3.4 mm (0.133 inch)
High	High	5.0 mm (0.196 inch)	3.6 mm (0.142 inch)	2.8 mm (0.112 inch)

Adjusting the Reel Speed

Use the reel-speed-control knob (Figure 15) to adjust the reel speed.

- **High reel speed:** Rotate the knob so that the “H” on the knob is directed toward the front of the machine.
- **Low reel speed:** Rotate the knob so that the “L” on the knob is directed toward the front of the machine.

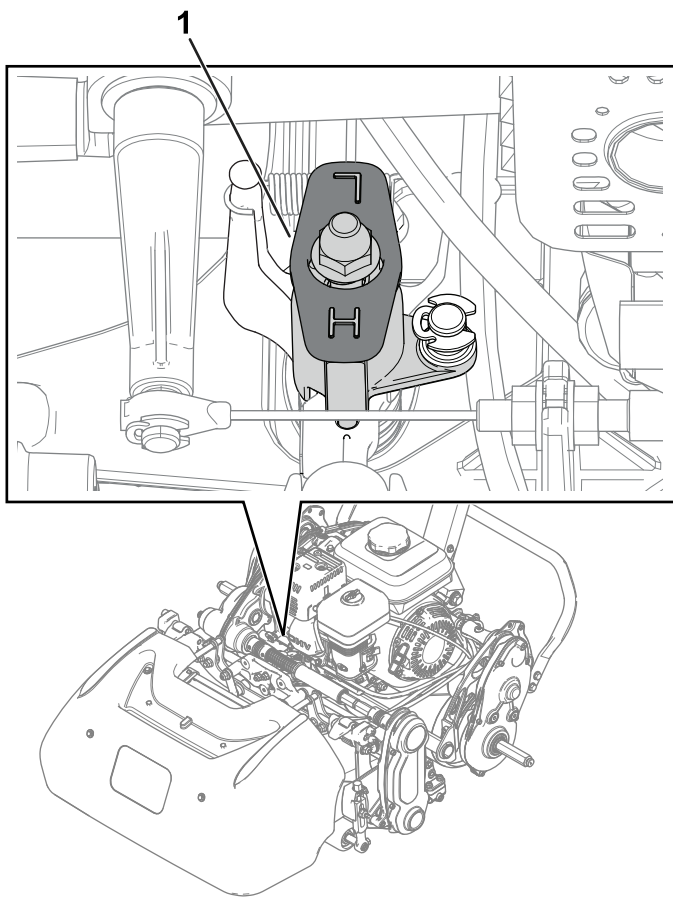

Figure 15

g307646

1. Reel-speed-control knob (shown in the high-reel-speed position)

Adjusting the Handle Height

Use the handle-height adjuster to adjust the handle height to a comfortable operating position; refer to [Handle-Height Adjuster \(page 11\)](#).

Transporting the Machine to a Job Site

Transporting the Machine Using Transport Wheels

Use the transport wheels to transport the machine a shorter distance.

1. Install the transport wheels; refer to [Installing the Transport Wheels \(page 20\)](#).
2. Ensure that the traction and reel-drive controls are in the NEUTRAL position.
3. Start the engine; refer to [Starting the Engine \(page 18\)](#).

4. Set the throttle control to SLOW, tip the front of the machine up, gradually engage the traction drive, and slowly increase the engine speed.
5. Adjust the throttle to operate the mower at the desired ground speed and transport the machine to the desired destination.

Transporting the Machine Using a Trailer

Use a trailer to transport the machine a considerable distance. Use caution while loading and unloading the machine onto the trailer.

1. Carefully drive the machine onto the trailer.
2. Shut off the engine, engage the parking brake, and turn the fuel valve to the OFF position.
3. Use a full-width ramp for loading the machine into a trailer or truck.
4. Securely fasten the machine to the trailer.

Note: You can use the Toro Trans Pro trailer to transport the machine. For instructions on loading the trailer, refer to your trailer *Operator's Manual*.

Important: Do not run the engine while transporting it on a trailer because damage can occur to the machine.

Removing the Transport Wheels

1. Release the clutch bail, use the throttle control to lower the engine speed, and shut off the engine.
2. Move the kickstand to the TRANSPORT-WHEEL-SERVICE position; refer to [Kickstand \(page 11\)](#).
3. Remove the transport wheels by pushing the wheel-locking clips out of the axles ([Figure 16](#)).

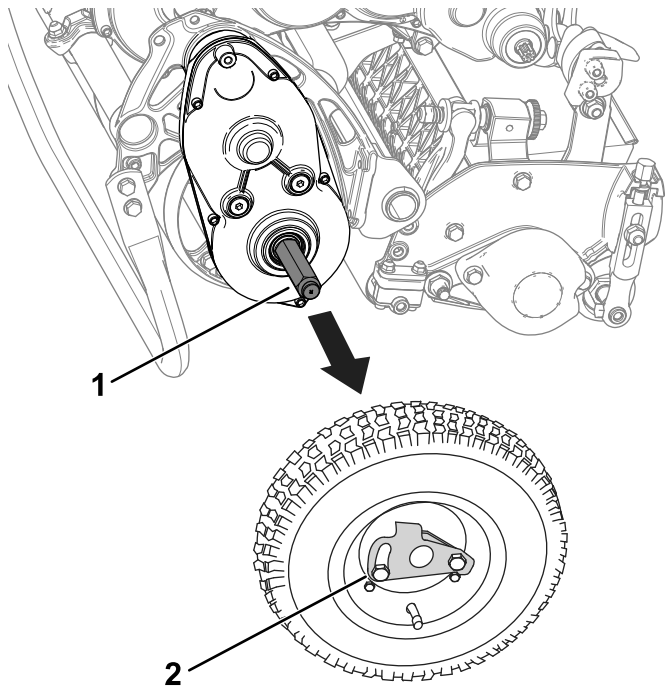

Figure 16

g307660

1. Axle
2. Wheel-locking clip

4. Carefully lower the machine off of the kickstand by pushing forward slowly or by lifting the lower handle support, allowing the kickstand to spring back to the STORAGE position; refer to [Kickstand \(page 11\)](#).

Using the Choke Lever

Use the choke lever to aid in starting a cold engine. Move the lever to the CHOKE position when starting a cold engine. After the engine starts, move the lever to the RUN position.

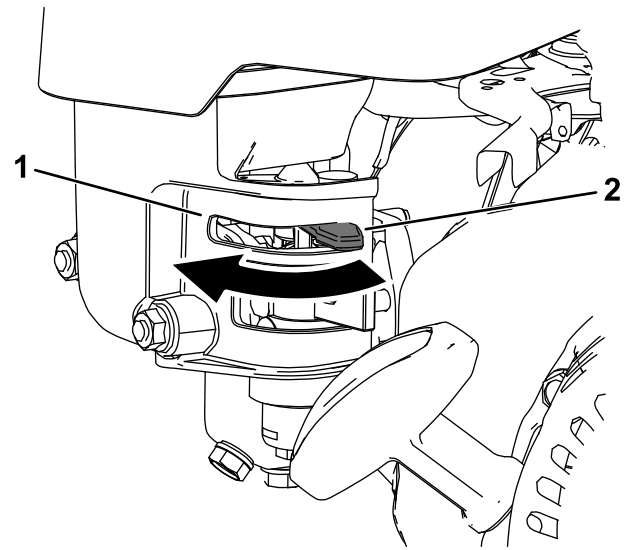

Figure 17

g273508

1. Choke lever—CHOKE position
2. Choke lever—RUN position

Opening and Closing the Fuel-Shutoff Valve

Control fuel flow to the engine with the fuel-shutoff valve as follows:

- To open the fuel valve, turn the fuel-shutoff lever toward the recoil starter handle ([Figure 18](#)).
- To shut the fuel valve, turn the fuel-shutoff lever away from the recoil starter handle ([Figure 18](#)).

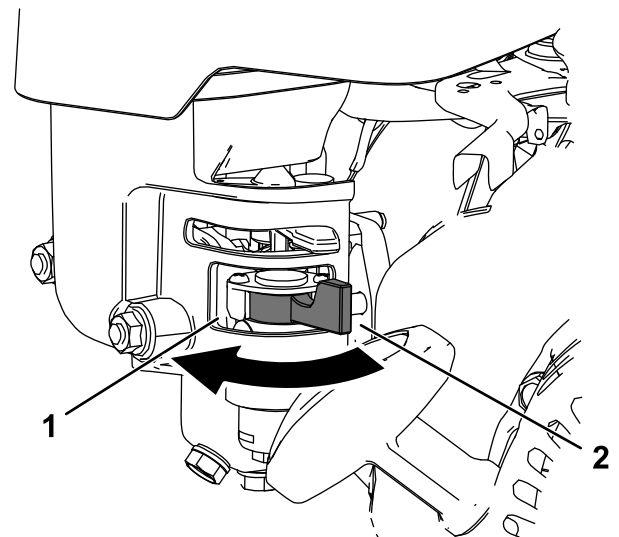

Figure 18

g273576

1. Fuel-shutoff lever—CLOSED position
2. Fuel-shutoff lever—OPEN position

During Operation

During Operation Safety

General Safety

- The owner/operator can prevent and is responsible for accidents that may cause personal injury or property damage.
- Wear appropriate clothing, including eye protection; long pants; substantial, slip-resistant footwear; and hearing protection. Tie back long hair and do not wear loose clothing or loose jewelry.
- Do not operate the machine while ill, tired, or under the influence of alcohol or drugs.
- Use your full attention while operating the machine. Do not engage in any activity that causes distractions; otherwise, injury or property damage may occur.
- Before you start the machine, ensure that all drives are in neutral, the parking brake is engaged, and you are in the operating position.
- Keep bystanders and children out of the operating area. If co-workers must be present, use caution and ensure that the grass basket is installed on the machine.
- Operate the machine only in good visibility to avoid holes or hidden hazards.
- Do not operate the machine when there is the risk of lightning.
- Use care when mowing on wet grass. Poor footing could cause a slip-and-fall accident.
- Keep your hands and feet away from the cutting unit.
- Look behind and down before backing up to be sure of a clear path.
- Use care when approaching blind corners, shrubs, trees, or other objects that may obscure your vision.
- Stop the cutting unit whenever you are not mowing.
- Disengage the drive to the cutting unit and shut off the machine before adjusting the height of cut.
- Never run an engine in an area where exhaust gasses are enclosed.
- Never leave a running machine unattended.
- Before you leave the operator's position, do the following:
 - Park the machine on a level surface.
 - Disengage the cutting unit(s).
 - Engage the parking brake.
 - Shut off the machine and remove the key (if equipped).
 - Wait for all movement to stop.
- Shut off the machine before emptying the basket.
- Do not touch the engine, muffler, or exhaust pipe while the engine is running or soon after it has shut off because these areas could be hot enough to cause burns.
- Shut off the machine and disengage the drive to the cutting unit in the following situations:
 - Before fueling
 - Before clearing blockages
 - Before removing the grass basket
 - Before checking, cleaning, or maintaining the cutting unit
 - After striking a foreign object or if an abnormal vibration occurs. Inspect the cutting unit for damage and make repairs before starting and operating the machine
 - Before leaving the operating position
- Use only accessories and attachments approved by The Toro® Company.

Slope Safety

- Slopes are a major factor related to loss of control and rollover accidents, which can result in severe injury or death. You are responsible for safe slope operation. Operating the machine on any slope requires extra caution. Before using the machine on a slope, do the following:
 - Review and understand the slope instructions in the manual and on the machine.
 - Evaluate the site conditions of the day to determine if the slope is safe for machine operation. Use common sense and good judgment when performing this evaluation. Changes in the terrain, such as moisture, can quickly affect the operation of the machine on a slope.
- Operate across slopes, never up and down. Avoid operation on excessively steep or wet slopes. Poor footing could cause a slip-and-fall accident.
- Identify hazards at the base of the slope. Do not operate the machine near drop-offs, ditches, embankments, water, or other hazards. The machine could suddenly roll over if a wheel goes over the edge or the edge collapses. Keep a safe distance between the machine and any hazard. Use a handheld tool to operate in these areas.
- Avoid starting, stopping, or turning the machine on slopes. Avoid making sudden changes in speed or direction; turn slowly and gradually.

- Do not operate a machine under any conditions where traction, steering, or stability is in question. Be aware that operating the machine on wet grass, across slopes, or downhill may cause the machine to lose traction. Loss of traction to the drive may result in sliding and a loss of braking and steering. The machine can slide even if you stop the drive.
- Remove or mark obstacles such as ditches, holes, ruts, bumps, rocks, or other hidden hazards. Tall grass can hide obstacles. Uneven terrain could overturn the machine.
- If you lose control of the machine, step away from the direction of travel of the machine.
- Always keep the machine in gear when going down slopes. Do not coast downhill (applicable only to gear-drive units).

Starting the Engine

Note: For illustrations and descriptions of the controls referenced in this section, refer to [Controls \(page 10\)](#).

Note: Ensure that the spark-plug wire is installed on the spark plug.

1. Ensure that the traction-drive lever is in the neutral position.
2. Ensure that the fuel-shutoff valve is open; refer to [Opening and Closing the Fuel-Shutoff Valve \(page 16\)](#)
3. Move the On/Off switch to the ON position.
4. Use the throttle control to increase the engine speed.
5. Move the choke lever halfway between the CHOKE and RUN positions when starting a cold engine; refer to [Using the Choke Lever \(page 16\)](#)

Note: The choke may not be required when starting a warm engine.

6. Pull the recoil-start handle out until positive engagement results, then pull it vigorously to start the engine.

Important: Do not pull the recoil rope to its limit or let go of the starter handle when the rope is pulled out; the rope may break or the recoil assembly may be damaged.

7. Move the choke lever to the RUN position as the engine warms up.

Operating Tips

Important: Grass clippings act as a lubricant when mowing. Operating the cutting unit excessively without grass clippings can damage the cutting unit.

- Mow the greens in a straight back-and-forth direction across the green.
- Avoid circular mowing or turning the machine on the greens areas to prevent scuffing.
- Turn the machine off the green by raising the cutting reel (pushing the handle down) and performing a tear-shaped turn on the traction drum ([Figure 19](#)).

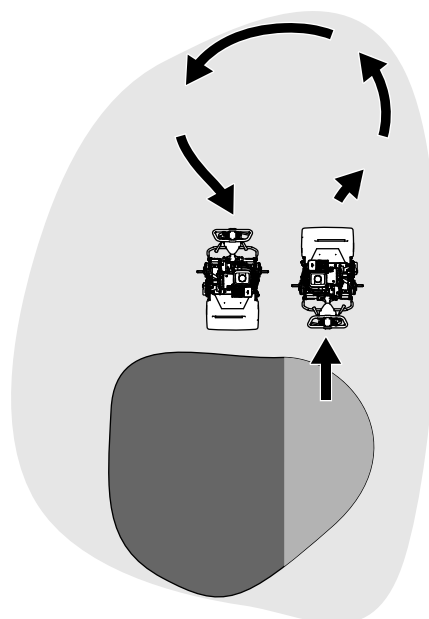

Figure 19

g271799

- Mow at a normal walking pace. Fast speeds saves little time and results in an inferior mowing job.
- To assist in maintaining a straight line across the green and to keep the machine an equal distance from the edge of the previous cut, use the alignment stripes on the basket ([Figure 20](#)).

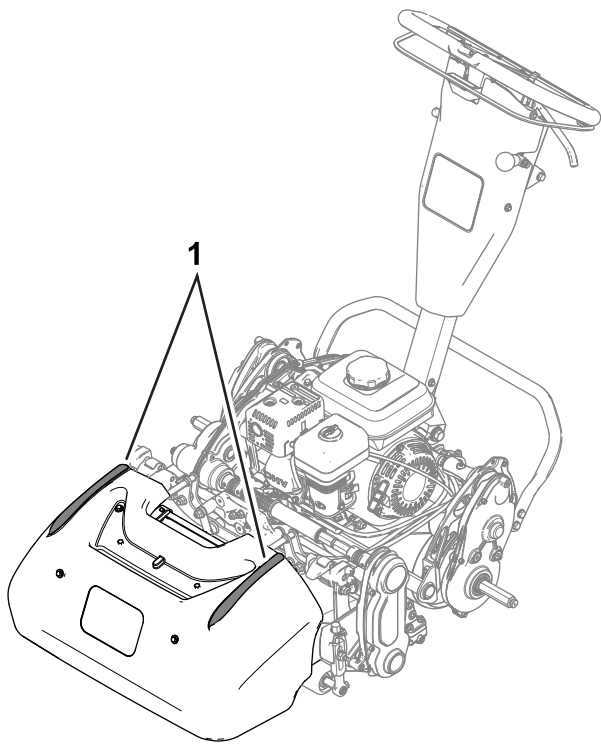

Figure 20

g309985

1. Alignment stripes

Operating the Machine in Low Light Conditions

Use the LED Light Kit when you operate the machine in low light conditions. Contact your authorized Toro distributor for this kit.

Important: Do not use other light systems with this machine, as they will not operate properly with the engine AC output.

Operating the Controls while Mowing

1. Start the engine, set the throttle to a reduced speed, push down on the handle to raise the cutting unit, and engage the traction drive to transport the machine onto the collar or approach of the green.
2. Stop the machine on the collar or the approach.
3. Increase the throttle speed, engage the cutting unit, engage the traction drive to move the machine onto the green, lower the cutting unit to the ground, and begin mowing.

Shutting Off the Engine

1. Release the clutch bail.
2. Move the throttle control to the SLOW position.
3. Move the On/Off switch to the OFF position.
4. Close the fuel-shutoff valve before you store or transport the machine

After Operation

After Operation Safety

General Safety

- Shut off the machine, remove the key (if equipped), and wait for all movement to stop before you leave the operator's position. Allow the machine to cool before adjusting, servicing, cleaning, or storing it.
- Clean grass and debris from the machine to help prevent fires. Clean up oil or fuel spills.
- Allow the machine to cool before storing the machine in any enclosure.
- Do not store the machine or fuel container where there is an open flame, spark, or pilot light, such as on a water heater or on other appliances.
- Reduce the throttle setting before shutting off the engine and turn off the fuel-shutoff valve (if equipped) after mowing.

Operating the Controls after Mowing

1. Drive the machine off of the green, push down on the handle to raise the cutting unit, release the clutch bail, disengage the cutting unit, and shut off the engine.
2. Remove the grass basket and empty the basket of clippings.
3. Install the grass basket on the machine and transport the machine to storage.

Transporting the Machine

After mowing, transport the machine away from the job site; refer to [Transporting the Machine Using Transport Wheels \(page 15\)](#) or [Transporting the Machine Using a Trailer \(page 15\)](#).

Installing the Transport Wheels

1. Move the kickstand to the TRANSPORT-WHEEL-SERVICE position; refer to [Kickstand \(page 11\)](#)
2. Slide a wheel onto an axle ([Figure 21](#)).

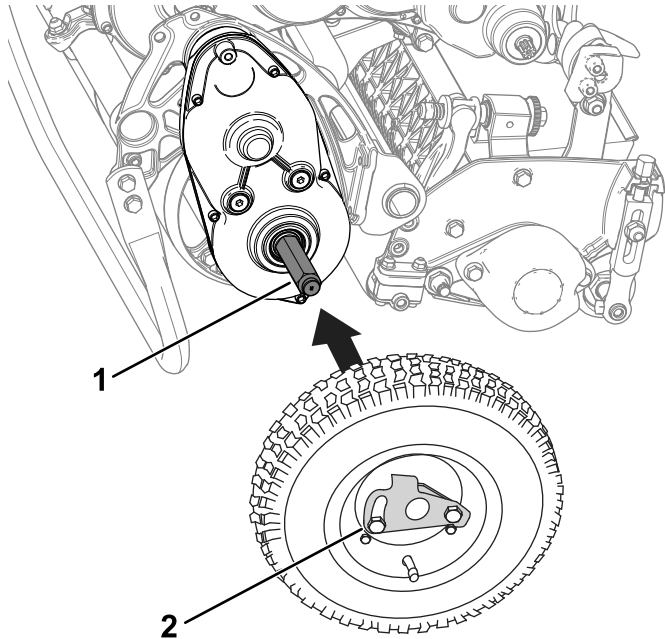

Figure 21

g307661

1. Axle
2. Wheel-locking clip

3. Pivot the wheel-locking clip ([Figure 21](#)) away from center of the wheel, allowing it to slide farther onto the axle.
4. Rotate the wheel back and forth until it slides completely onto the axle and the locking clip is secured in the groove on the axle shaft.
5. Repeat the procedure on the opposite side of the machine.
6. Carefully lower the machine off the kickstand.

Engaging or Disengaging the Transmission

You can disengage the drum from the transmission to allow the machine to be maneuvered. Disengage the transmission when you need to move the machine without starting the engine (e.g., performing maintenance in an enclosed area).

Before you operate the machine, ensure that you engage the transmission.

1. Locate the traction-engagement lever on the transmission gearbox ([Figure 19](#)).

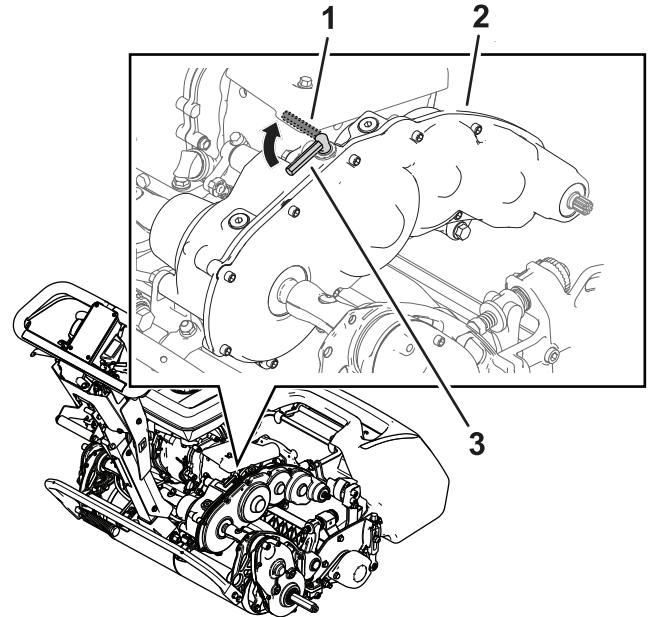

Figure 22

g345112

1. Traction-engagement lever—DISENGAGED position
2. Transmission gearbox
3. Traction-engagement lever—ENGAGED position

2. Perform the following step to engage or disengage the transmission:
 - **Disengage the transmission:** Rotate the lever to the DISENGAGED position.
 - **Engage the transmission:** Rotate the lever to the ENGAGED position.

Maintenance

▲ WARNING

Failure to properly maintain the machine could result in premature failure of machine systems, causing possible harm to you or bystanders.

Keep the machine well maintained and in good working order as indicated in these instructions.

Note: Determine the left and right sides of the machine from the normal operating position.

Important: Do not tip the machine at an angle greater than 25°. Tipping the machine beyond 25° leads to oil leaking into the combustion chamber and/or fuel leaking out of the fuel-tank cap.

Important: Refer to your engine owner's manual for additional maintenance procedures.

Maintenance Safety

- Before you leave the operator's position, do the following:
 - Park the machine on a level surface.
 - Move the throttle to the low-idle position.
 - Disengage the cutting unit(s).
 - Ensure that the traction is in neutral.
 - Engage the parking brake.
 - Shut off the machine and remove the key (if equipped).
 - Wait for all movement to stop.
- Allow machine components to cool before performing maintenance.
- If possible, do not perform maintenance while the machine is running. Keep away from moving parts.
- If the engine must be running to perform a maintenance adjustment, keep your hands, feet, clothing, and any parts of the body away from the cutting unit, attachments, and any moving parts. Keep bystanders away.
- Clean grass and debris from the cutting unit, drive, muffler, cooling screen, and the engine to help prevent fires. Clean up oil or fuel spills.
- Keep all parts in good working condition. Replace all worn, damaged, or missing parts and decals. Keep all hardware tight to ensure that the machine is in safe working condition.
- Check the grass catcher components frequently and replace them when necessary.
- To ensure safe, optimal performance of the machine, use only genuine Toro replacement parts. Replacement parts made by other manufacturers could be dangerous, and such use could void the product warranty.
- If major repairs are ever needed or if assistance is desired, contact an authorized Toro distributor.

Recommended Maintenance Schedule(s)

Maintenance Service Interval	Maintenance Procedure
After the first 20 hours	<ul style="list-style-type: none">• Change the engine oil.• Tighten the handle-isolation hardware.
Before each use or daily	<ul style="list-style-type: none">• Check the engine-oil level.• Inspect the air-filter elements.
Every 50 hours	<ul style="list-style-type: none">• Clean the air-filter elements.
Every 100 hours	<ul style="list-style-type: none">• Change the engine oil.• Inspect and adjust the spark plug; replace it if necessary.
Every 300 hours	<ul style="list-style-type: none">• Replace the paper filter element (More frequently in dusty operating conditions).• Replace the spark plug.

Daily Maintenance Checklist

Important: Duplicate this page for routine use.

Maintenance Check Item	For the week of:						
	Mon.	Tues.	Wed.	Thurs.	Fri.	Sat.	Sun.
Check the brake-lock-lever operation.							
Check the fuel level.							
Check the engine-oil level.							
Check the air filter.							
Clean the engine cooling fins.							
Check for unusual engine noises.							
Check for unusual operating noises.							
Check the reel-to-bedknife adjustment.							
Check the height-of-cut adjustment.							
Touch up damaged paint.							
Clean the machine.							

Notation for Areas of Concern

Inspection performed by:		
Item	Date	Information

Pre-Maintenance Procedures

Preparing the Machine for Maintenance

⚠ WARNING

While you are maintaining or adjusting the machine, someone could start the engine. Accidentally starting the engine could seriously injure you or other bystanders.

Release the clutch bail, engage the parking brake, and pull the wire off the spark plug before you do any maintenance. Also push the wire aside so it does not accidentally contact the spark plug.

Perform the following before servicing, cleaning, or making any adjustments to the machine.

1. Park the machine on a level surface.
2. Shut off the engine.
3. Engage the parking brake.
4. Wait for all moving parts to stop and allow the engine to cool before servicing, storing, or making repairs.
5. Disconnect the spark-plug wire (Figure 23).

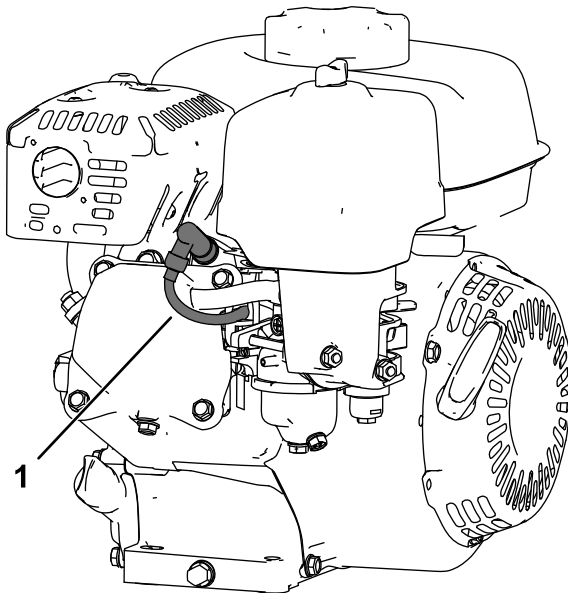

Figure 23

g265998

1. Spark-plug wire

Engine Maintenance

Engine Safety

- Do not change the governor speed or overspeed the engine.
- Run the engine dry or remove the fuel with a hand pump; never siphon the fuel. If you must drain the fuel tank, do it outdoors.

Servicing the Engine Oil

Fill the crankcase with approximately 0.56 L (19 fl oz) of the proper viscosity oil before starting. The engine uses a high-quality oil that has the American Petroleum Institute (API) service classification of SJ or higher. Select the proper oil viscosity (weight) based on the ambient temperature. Figure 24 illustrates the temperature/viscosity recommendations.

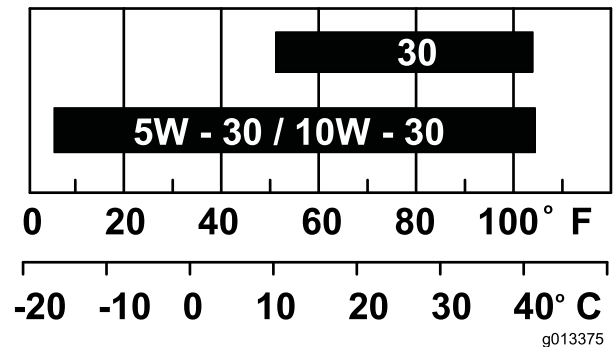

g013375

g013375

Figure 24

Note: Multi-grade oils (5W-20, 10W-30 and 10W-40) increase oil consumption. Check the engine-oil level more frequently when you use these oils.

Checking the Engine-Oil Level

Service Interval: Before each use or daily

The ideal time to check the engine-oil level is when the engine is cool or before you have started the engine for the day. If you have already ran the engine, allow the oil to drain back down to the sump for at least 10 minutes before you check the engine-oil level.

1. Shut off the engine and wait for all moving parts to stop; refer to [Shutting Off the Engine \(page 19\)](#).
2. Position the machine so that the engine is level, and clean the area around the oil-fill tube (Figure 25).

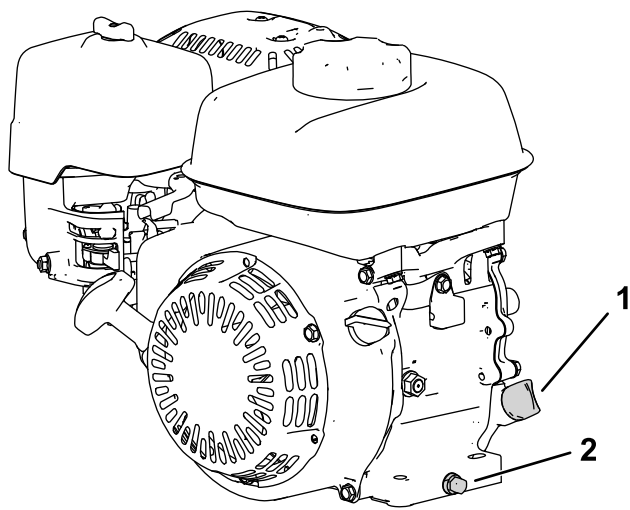

Figure 25

g266053

1. Dipstick 2. Drain plug and washer

3. Remove the dipstick by rotating it counterclockwise.
4. Remove the dipstick and wipe the end clean.
5. Insert the dipstick fully into the oil-fill tube, **but do not thread it in.**
6. Remove the dipstick and check the engine-oil level (Figure 26).

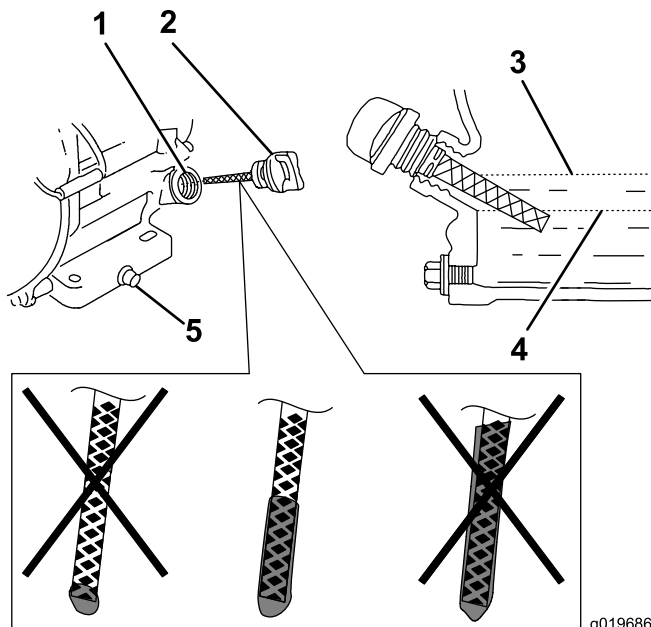

Figure 26

g019686
g019686

1. Filler tube 4. Lower limit
2. Dipstick 5. Drain plug
3. Upper limit

7. If the engine-oil level is incorrect, add or drain oil to correct the level; refer to [Checking the Engine-Oil Level \(page 23\)](#).

Changing the Engine Oil

Service Interval: After the first 20 hours/After the first month (whichever comes first)

Every 100 hours/Every 6 months (whichever comes first)

⚠ WARNING

Oil may be hot after the engine has been run, and contact with hot oil can cause severe personal injury.

Avoid contacting the hot engine oil when you drain it.

1. Shut off the engine and wait for all moving parts to stop; refer to [Shutting Off the Engine \(page 19\)](#).
 2. Place a pan under the drain plug to catch the oil.
 3. Remove the drain plug, washer, and dipstick (Figure 25).
 4. Position the engine so that the oil drains from the engine.
 5. When the oil has drained completely, move the engine to a level position and install the drain plug and a new washer.
- Note:** Dispose of the used oil at a certified recycling center.
6. Slowly pour oil into the oil-fill hole until the oil is at the correct level.
 7. Ensure that the oil is at the correct level on the dipstick; refer to [Checking the Engine-Oil Level \(page 23\)](#).
 8. Thread the dipstick into the oil-fill hole.
 9. Wipe up any spilled oil.
 10. Connect the wire to the spark plug.

Servicing the Air Cleaner

Service Interval: Before each use or daily

Every 50 hours/Every 3 months (whichever comes first)

Every 300 hours/Yearly (whichever comes first)

Important: Do not operate the engine without the air filter assembly; extreme engine damage will occur.

1. Shut off the engine and wait for all moving parts to stop; refer to [Shutting Off the Engine \(page 19\)](#).
2. Remove the wingnut securing the air-cleaner cover (Figure 27).
3. Remove the air-cleaner cover.

Note: Ensure that no dirt or debris from the air-cleaner cover fall into the base.

4. Remove the foam and paper elements from the base.
5. Remove the foam element from the paper element.
6. Inspect the foam and paper elements; replace them if they are damaged or excessively dirty.

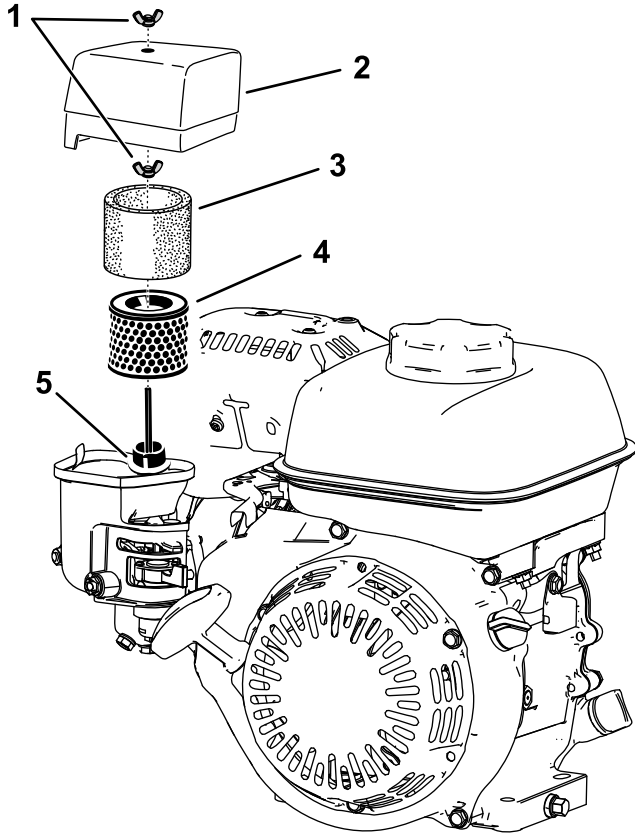

Figure 27

g265999

- | | |
|----------------------|-------------------------|
| 1. Wing nut | 4. Paper filter element |
| 2. Air-cleaner cover | 5. Gasket and air duct |
| 3. Foam element | |

7. Clean the paper element by tapping it gently to remove the dirt.

Note: Do not try to brush dirt off the paper element; brushing forces the dirt into the fibers. Replace the element if tapping it fails to remove the dirt.

8. Clean the foam element in warm, soapy water or in a nonflammable solvent.

Note: Do not use gasoline to clean the foam element because it could create a risk of fire or explosion.

9. Rinse and dry the foam element thoroughly.
10. Wipe dirt from the base and the cover with a moist rag.

Note: Ensure that dirt and debris do not enter the air duct leading to the carburetor.

11. Install the air-cleaner elements and ensure that they are properly positioned. Install the lower wing nut.
12. Install the cover and install the upper wing nut to secure it.

Servicing the Spark Plug

Service Interval: Every 100 hours/Every 6 months (whichever comes first)

Every 300 hours/Yearly (whichever comes first)

Use an NGK BPR6ES spark plug or equivalent.

1. Shut off the engine and wait for all moving parts to stop; refer to [Shutting Off the Engine \(page 19\)](#).
2. Clean around the spark plug.
3. Remove the spark plug from the cylinder head.

Important: Replace a cracked, fouled, or dirty spark plug. Do not sand blast, scrape, or clean the electrodes because engine damage could result from grit entering the cylinder.

4. Set the gap on the plug to 0.7 to 0.8 mm (0.028 to 0.031 inch)

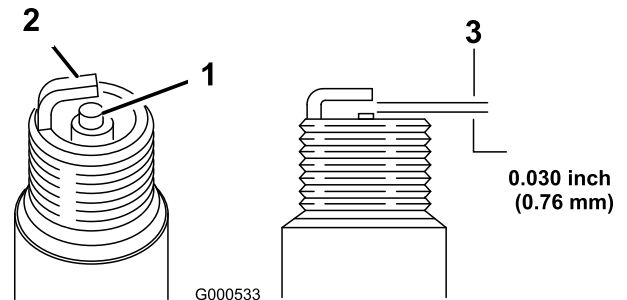

G000533

g000533

Figure 28

- | | |
|-------------------------------|------------|
| 1. Center-electrode insulator | 3. Air gap |
| 2. Side electrode | |

5. Carefully install the spark plug by hand (to avoid cross threading) until it is hand tight.
6. Tighten the spark plug an additional 1/2 turn if it is new; otherwise, tighten it an additional 1/8 to 1/4 turn.

Important: A loose spark plug can become very hot and can damage the engine; overtightening a spark plug may damage the threads in the cylinder head.

7. Connect the wire to the spark plug.

Controls System Maintenance

Adjusting the Traction Cable

Adjust the traction cable to achieve a gap of 1.1 mm (0.045 inch) between the friction disc and the pressure plate.

1. Access the friction disc and pressure plate by removing the clutch cover (Figure 29).

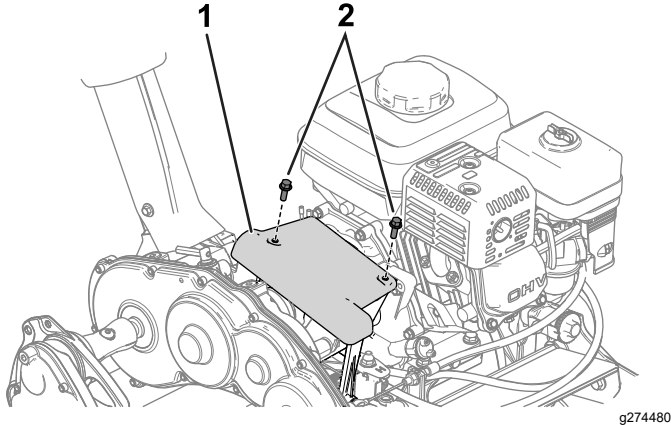

Figure 29

1. Clutch cover
2. Bolt

2. Loosen the jam nuts and adjust the traction cable so that a 1.1 mm (0.045 inch) gap is between the friction disc and the pressure plate (Figure 30 and Figure 31).

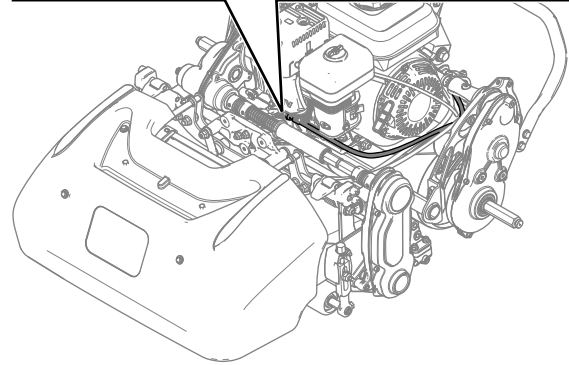
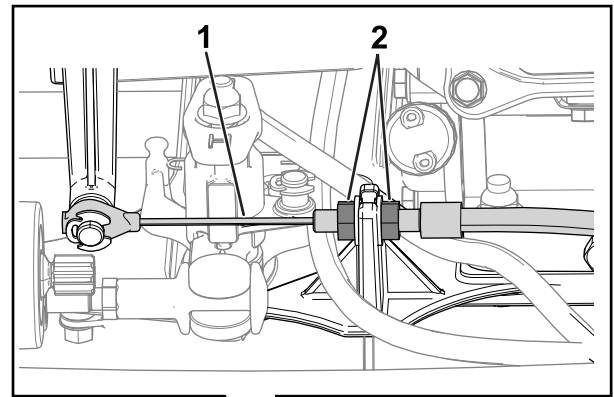

Figure 30

g309987

1. Traction cable
2. Jam nut

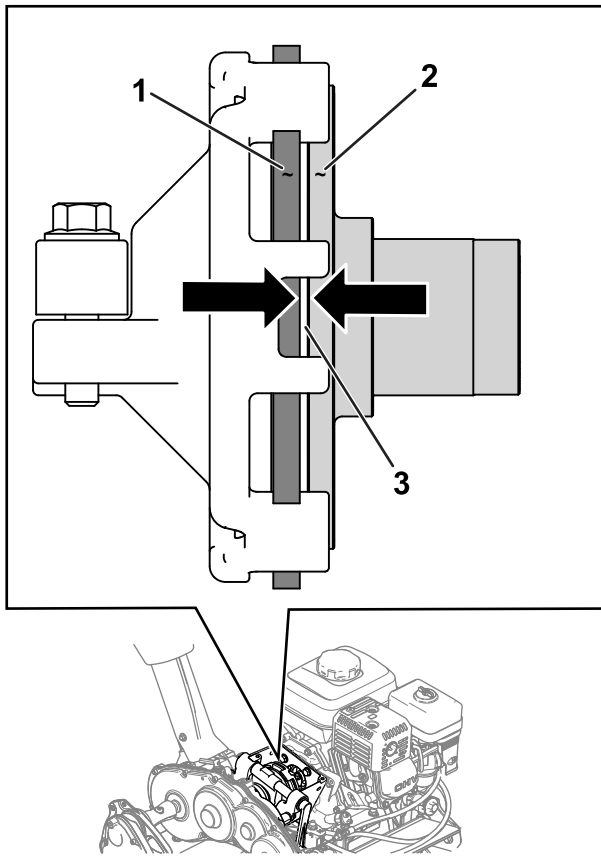

Figure 31

g274479

1. Friction disc
2. Pressure plate
3. Gap—1.1 mm (0.045 inch)

Adjusting the Service/Parking Brake

Adjust the service/parking brake if it slips during operation.

1. Disengage the parking brake.
2. Measure the free play at the end of the parking-brake handle ([Figure 32](#)).

The handle free play should be between 12.7 to 25.4 mm (0.50 to 1 inch). If the free play is not within this amount, proceed to [step 3](#) to adjust the brake cable.

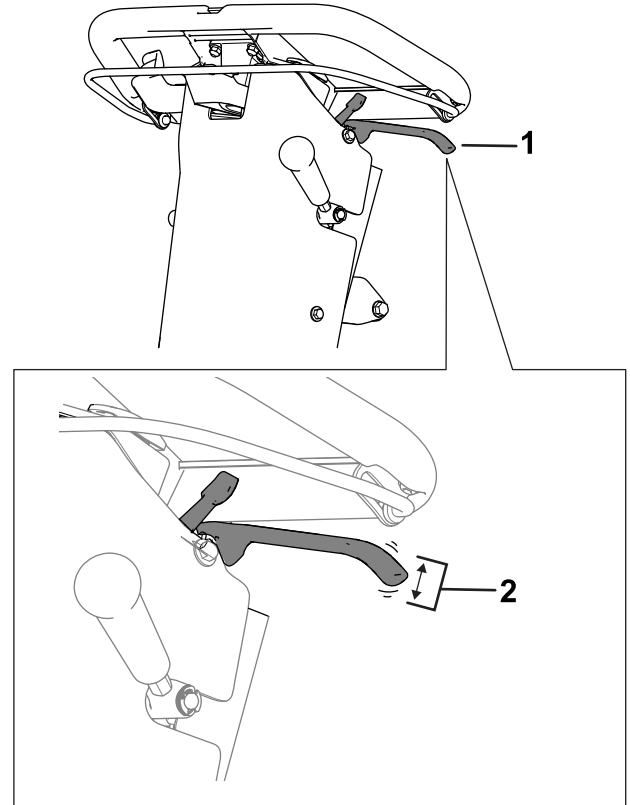

g373542

Figure 32

1. Parking-brake handle
2. Appropriate free play of 12.7 to 25.4 mm (0.50 to 1 inch).

3. Perform the following steps to adjust the brake-cable tension:
 - To increase the cable tension, loosen the front-cable jam nut and tighten the rear jam nut ([Figure 33](#)). Repeat [step 2](#) and adjust the tension if necessary.
 - To decrease the cable tension, loosen the rear jam nut and tighten the front-cable jam nut ([Figure 33](#)). Repeat [step 2](#) and adjust the tension if necessary.

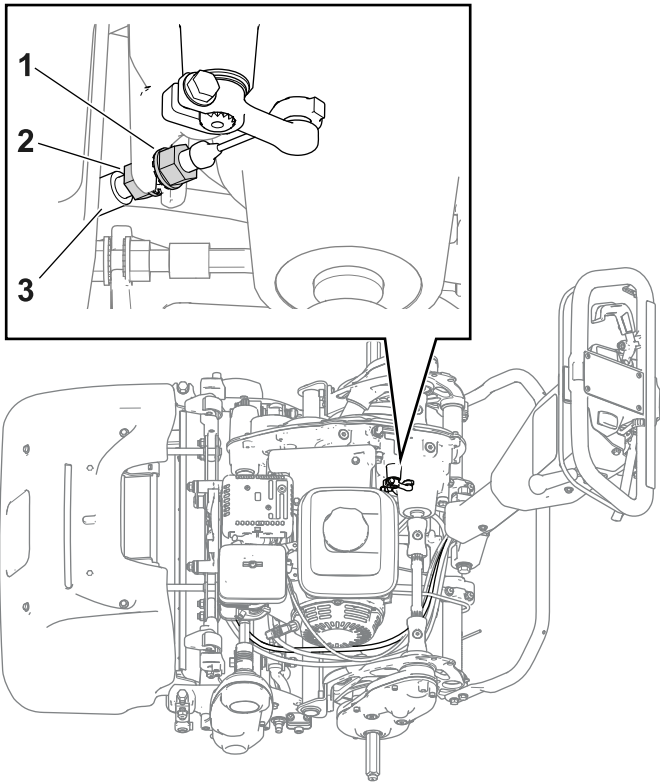

Figure 33

g344197

1. Front-cable jam nut
2. Rear jam nut
3. Brake cable

Adjusting the Reel-Control Cable

To remove slack from the reel-control cable, perform the following steps:

1. Move the reel-speed-control knob to the high-reel-speed position; refer to [Adjusting the Reel Speed \(page 14\)](#).
2. Loosen the rear jam nut and tighten the front jam nut ([Figure 34](#)).

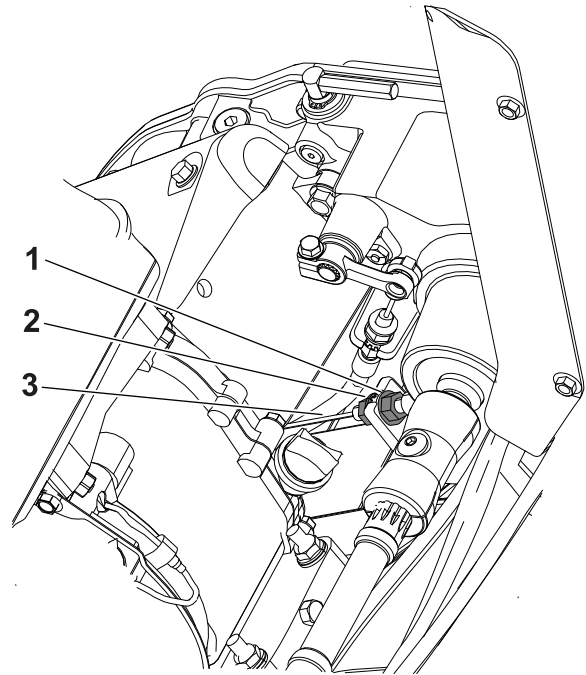

Figure 34

g311125

1. Rear jam nut
2. Front jam nut
3. Reel-control cable

Adjusting the Throttle Cable

To adjust the low- and high-idle engine speed, adjust the cable conduit and the throttle-control stop; refer to [Adjusting the Low-Idle Engine Speed \(page 28\)](#) and [Adjusting the High-Idle Engine Speed \(page 29\)](#).

Adjusting the Low-Idle Engine Speed

Note: Use a tachometer to observe the engine speed.

1. Park the machine on a level surface and engage the parking brake.

Note: Ensure that the engine is at a normal operating temperature before you adjust the throttle cable.

2. Start the engine and use the throttle control to decrease the engine speed to low idle.
3. Observe the low-idle engine speed on your tachometer.

The ideal range for low idle is **1,800 to 2,000 rpm**.

4. Loosen the screw on the cable-conduit clamp (Figure 35).

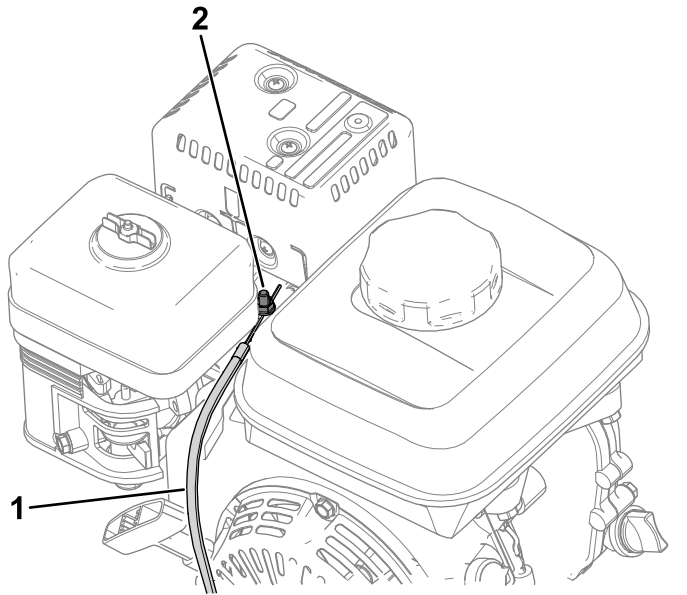

Figure 35

g315295

1. Throttle cable
2. Cable-conduit-clamp screw

5. Move the cable conduit until you observe 1,900 rpm on the tachometer.
6. Tighten the screw on the cable-conduit clamp.

Adjusting the High-Idle Engine Speed

Note: Use a tachometer to observe the engine speed.

1. Park the machine on a level surface and engage the parking brake.

Note: Ensure that the engine is at a normal operating temperature before you adjust the throttle cable.

2. Start the engine and use the throttle control to increase the engine speed to high idle.
3. Observe the high-idle engine speed on your tachometer.

The ideal range for high idle (for use in non-CE-compliant countries) is **3,350 to 3,550 rpm**. If the tachometer shows a speed below 3,350 or above 3,550 rpm, perform steps 4 through 6 until a speed between 3,350 to 3,550 rpm is attained.

If you use the machine in a country that complies to CE standards, adjust the high idle speed to the following specifications:

- Flex 1018 machines: **3,000 rpm**
- Flex 1021 machines: **3,150 rpm**

4. Shut off the engine.
5. Adjust the throttle-control stop per the high-idle reading on your tachometer.
 - To **increase** the high-idle-speed threshold, move the throttle-control stop **up**.
 - To **decrease** the high-idle-speed threshold, move the throttle-control stop **down**.

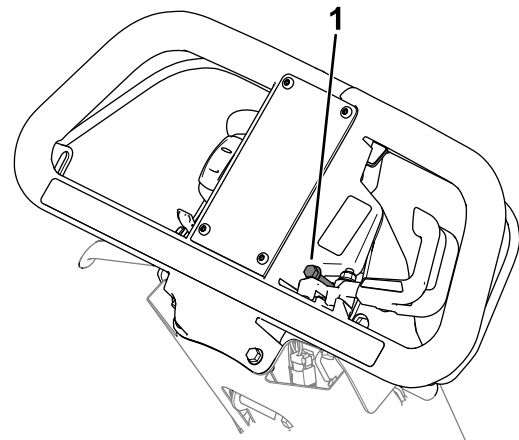

Figure 36

g315976

1. Throttle-control stop
6. Start the engine and observe the new high-idle reading.

If the tachometer shows the appropriate speed as detailed in step 3, the adjustment is completed.

Tightening the Handle-Isolation Hardware

Service Interval: After the first 20 hours

1. Position the machine on a level surface.
2. Loosen the bolt and nut as shown in [Figure 37](#).

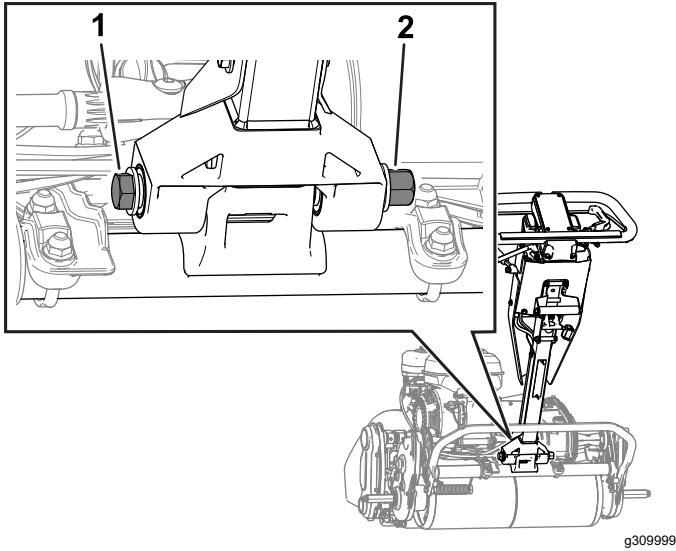

Figure 37

1. Bolt
2. Nut

3. Push the handle as far forward as possible.
4. While supporting the handle, torque the bolt and nut that you loosened in step 2 to 68 to 75 N·m (50 to 55 ft-lb).

Note: Have an assistant help you to support the handle or torque the hardware.

5. Release the handle.

Cutting Unit Maintenance

Blade Safety

Use care when checking the reel cutting-unit. Wear gloves and use caution when servicing the reel.

A worn or damaged blade or bedknife can break, and a piece could be thrown toward you or bystanders, resulting in serious personal injury or death.

- Inspect the blades and bedknives periodically for excessive wear or damage.
- Use care when checking the blades. Wear gloves and use caution when servicing them. Only replace or backlap the blades and bedknives; never straighten or weld them.

Installing the Cutting Unit

1. Move the kickstand to the CUTTING-UNIT-SERVICE position; refer to [Kickstand \(page 11\)](#).
2. Align the cutting unit to the frame.
3. Move the suspension latches down to secure the cutting unit to the machine ([Figure 38](#)).

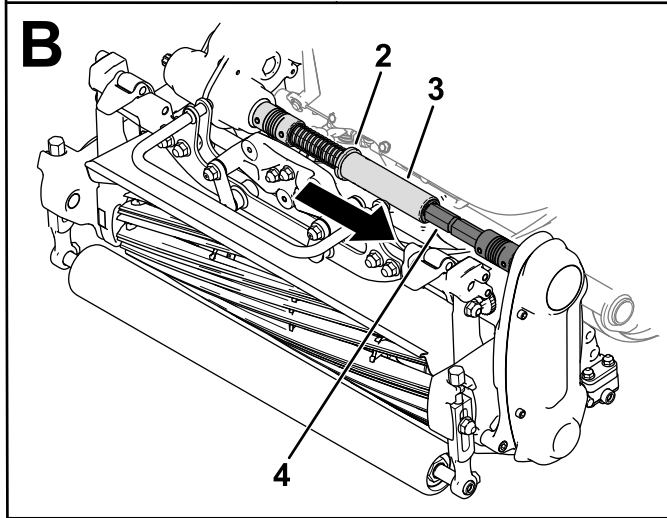
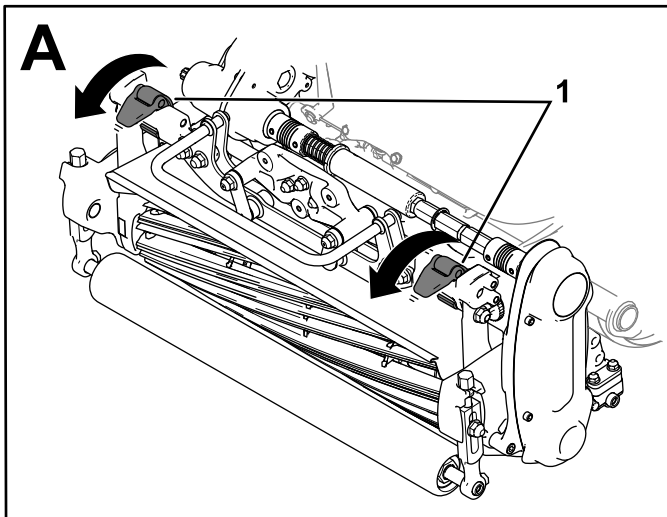

Figure 38

g307906

- | | |
|------------|------------------|
| 1. Latches | 3. Hex tube |
| 2. Collar | 4. Coupler shaft |

4. Move the collar out of the transmission-coupler-shaft groove and insert the hex tube into the cutting-unit coupler shaft (Figure 38).
5. Install the grass basket.

Removing the Cutting Unit

Note: The hex tube disengages if you engage the reel drive when the cutting unit is removed.

1. Move the kickstand to the CUTTING-UNIT-SERVICE position; refer to [Kickstand \(page 11\)](#).
2. Remove the grass basket (if equipped).
3. Move the collar (Figure 39) into the transmission-shaft groove.

Note: This releases tension from the spring.

4. Slide the hex tube off of the cutting-unit coupler shaft (Figure 39).

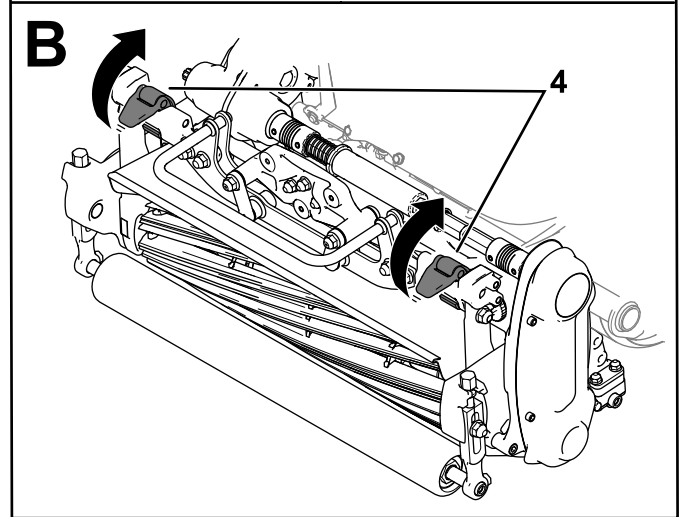
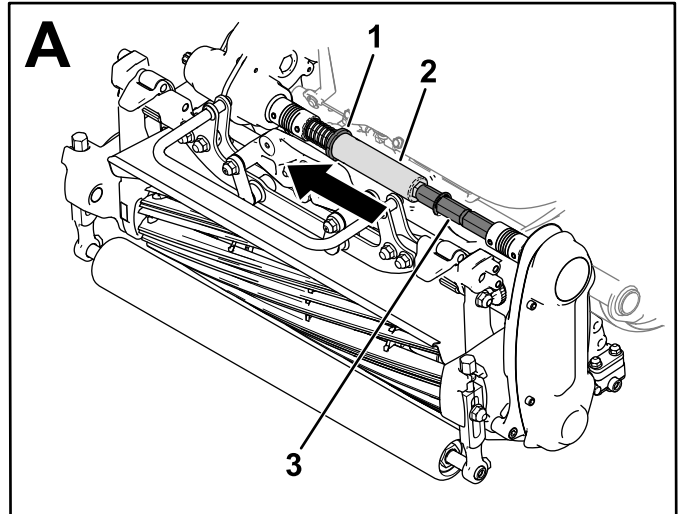

Figure 39

g307907

- | | |
|-------------|------------------|
| 1. Collar | 3. Coupler shaft |
| 2. Hex tube | 4. Latches |

5. Move the suspension latches up to release the cutting unit from the machine (Figure 39).
6. Remove the cutting unit from the frame.

Backlapping the Cutting Unit

To backlap the cutting unit, use the Access Backlap Kit (Model 139-4342); refer to the operating instructions in the kit *Installation Instructions*. Contact your authorized Toro distributor to acquire this kit.

Storage

Storage Safety

- Shut off the engine, remove the key (if equipped), and wait for all movement to stop before you leave the operator's position. Allow the machine to cool before adjusting, servicing, cleaning, or storing it.
- Do not store the machine or fuel container where there is an open flame, spark, or pilot light, such as on a water heater or other appliance.

Storing the Machine

1. Remove any grass clippings, dirt, and grime from the external parts of the entire machine, especially the engine. Clean the dirt and chaff from the outside of the engine cylinder-head fins and the blower housing.

Important: You can wash the machine with mild detergent and water. Do not pressure-wash the machine. Avoid excessive use of water, especially near the shift-lever plate and the engine.

2. For long-term storage (more than 30 days) add stabilizer/conditioner additive to the fuel in the tank.
 - A. Run the engine to distribute conditioned fuel through the fuel system for 5 minutes.
 - B. Either shut off the engine, allow it to cool, and drain the fuel tank, or operate the engine until it shuts off.
 - C. Start the engine and run it until it shuts off. Start the engine again, with the choke closed, until the engine does not start.
 - D. Disconnect the spark-plug wire from the spark plug.
 - E. Dispose of the fuel properly. Recycle it according to local codes.

Note: Do not store fuel containing stabilizer/conditioner longer than the duration recommended by the fuel-stabilizer manufacturer.

3. Check and tighten all bolts, nuts, and screws. Repair or replace any part that is worn or damaged.
4. Paint all scratched or bare metal surfaces. Paint is available from your authorized Toro distributor.
5. Store the machine in a clean, dry garage or storage area. Cover the machine to protect it and keep it clean.

Notes:

EEA/UK Privacy Notice

Toro's Use of Your Personal Information

The Toro Company ("Toro") respects your privacy. When you purchase our products, we may collect certain personal information about you, either directly from you or through your local Toro company or dealer. Toro uses this information to fulfil contractual obligations - such as to register your warranty, process your warranty claim or to contact you in the event of a product recall - and for legitimate business purposes - such as to gauge customer satisfaction, improve our products or provide you with product information which may be of interest. Toro may share your information with our subsidiaries, affiliates, dealers or other business partners in connection these activities. We may also disclose personal information when required by law or in connection with the sale, purchase or merger of a business. We will never sell your personal information to any other company for marketing purposes.

Retention of your Personal Information

Toro will keep your personal information as long as it is relevant for the above purposes and in accordance with legal requirements. For more information about applicable retention periods please contact legal@toro.com.

Toro's Commitment to Security

Your personal information may be processed in the US or another country which may have less strict data protection laws than your country of residence. Whenever we transfer your information outside of your country of residence, we will take legally required steps to ensure that appropriate safeguards are in place to protect your information and to make sure it is treated securely.

Access and Correction

You may have the right to correct or review your personal data, or object to or restrict the processing of your data. To do so, please contact us by email at legal@toro.com. If you have concerns about the way in which Toro has handled your information, we encourage you to raise this directly with us. Please note that European residents have the right to complain to your Data Protection Authority.



The Toro Warranty

Two-Year or 1,500 Hours Limited Warranty

Conditions and Products Covered

The Toro Company warrants your Toro Commercial product ("Product") to be free from defects in materials or workmanship for 2 years or 1,500 operational hours*, whichever occurs first. This warranty is applicable to all products with the exception of Aerators (refer to separate warranty statements for these products). Where a warrantable condition exists, we will repair the Product at no cost to you including diagnostics, labor, parts, and transportation. This warranty begins on the date the Product is delivered to the original retail purchaser.

* Product equipped with an hour meter.

Instructions for Obtaining Warranty Service

You are responsible for notifying the Commercial Products Distributor or Authorized Commercial Products Dealer from whom you purchased the Product as soon as you believe a warrantable condition exists. If you need help locating a Commercial Products Distributor or Authorized Dealer, or if you have questions regarding your warranty rights or responsibilities, you may contact us at:

Toro Commercial Products Service Department
8111 Lyndale Avenue South
Bloomington, MN 55420-1196

952-888-8801 or 800-952-2740
E-mail: commercial.warranty@toro.com

Owner Responsibilities

As the product owner, you are responsible for required maintenance and adjustments stated in your *Operator's Manual*. Repairs for product issues caused by failure to perform required maintenance and adjustments are not covered under this warranty.

Items and Conditions Not Covered

Not all product failures or malfunctions that occur during the warranty period are defects in materials or workmanship. This warranty does not cover the following:

- Product failures which result from the use of non-Toro replacement parts, or from installation and use of add-on, or modified non-Toro branded accessories and products.
- Product failures which result from failure to perform recommended maintenance and/or adjustments.
- Product failures which result from operating the Product in an abusive, negligent, or reckless manner.
- Parts consumed through use that are not defective. Examples of parts which are consumed, or used up, during normal Product operation include, but are not limited to, brake pads and linings, clutch linings, blades, reels, rollers and bearings (sealed or greasable), bed knives, spark plugs, castor wheels and bearings, tires, filters, belts, and certain sprayer components such as diaphragms, nozzles, flow meters, and check valves.
- Failures caused by outside influence, including, but not limited to, weather, storage practices, contamination, use of unapproved fuels, coolants, lubricants, additives, fertilizers, water, or chemicals.
- Failure or performance issues due to the use of fuels (e.g. gasoline, diesel, or biodiesel) that do not conform to their respective industry standards.
- Normal noise, vibration, wear and tear, and deterioration. Normal "wear and tear" includes, but is not limited to, damage to seats due to wear or abrasion, worn painted surfaces, scratched decals or windows.

Countries Other than the United States or Canada

Customers who have purchased Toro products exported from the United States or Canada should contact their Toro Distributor (Dealer) to obtain guarantee policies for your country, province, or state. If for any reason you are dissatisfied with your Distributor's service or have difficulty obtaining guarantee information, contact your Authorized Toro Service Center.

Parts

Parts scheduled for replacement as required maintenance are warranted for the period of time up to the scheduled replacement time for that part. Parts replaced under this warranty are covered for the duration of the original product warranty and become the property of Toro. Toro will make the final decision whether to repair any existing part or assembly or replace it. Toro may use remanufactured parts for warranty repairs.

Deep Cycle and Lithium-Ion Battery Warranty

Deep cycle and Lithium-Ion batteries have a specified total number of kilowatt-hours they can deliver during their lifetime. Operating, recharging, and maintenance techniques can extend or reduce total battery life. As the batteries in this product are consumed, the amount of useful work between charging intervals will slowly decrease until the battery is completely worn out. Replacement of worn out batteries, due to normal consumption, is the responsibility of the product owner. Note: (Lithium-Ion battery only): Refer to the battery warranty for additional information.

Lifetime Crankshaft Warranty (ProStripe 02657 Model Only)

The ProStripe which is fitted with a genuine Toro Friction Disc and Crank-Safe Blade Brake Clutch (integrated Blade Brake Clutch (BBC) + Friction Disc assembly) as original equipment and used by the original purchaser in accordance with recommended operating and maintenance procedures, are covered by a Lifetime Warranty against engine crankshaft bending. Machines fitted with friction washers, Blade Brake Clutch (BBC) units and other such devices are not covered by the Lifetime Crankshaft Warranty.

Maintenance is at Owner's Expense

Engine tune-up, lubrication, cleaning and polishing, replacement of filters, coolant, and completing recommended maintenance are some of the normal services Toro products require that are at the owner's expense.

General Conditions

Repair by an Authorized Toro Distributor or Dealer is your sole remedy under this warranty.

The Toro Company is not liable for indirect, incidental or consequential damages in connection with the use of the Toro Products covered by this warranty, including any cost or expense of providing substitute equipment or service during reasonable periods of malfunction or non-use pending completion of repairs under this warranty. Except for the Emissions warranty referenced below, if applicable, there is no other express warranty. All implied warranties of merchantability and fitness for use are limited to the duration of this express warranty.

Some states do not allow exclusions of incidental or consequential damages, or limitations on how long an implied warranty lasts, so the above exclusions and limitations may not apply to you. This warranty gives you specific legal rights, and you may also have other rights which vary from state to state.

Note Regarding Emissions Warranty

The Emissions Control System on your Product may be covered by a separate warranty meeting requirements established by the U.S. Environmental Protection Agency (EPA) and/or the California Air Resources Board (CARB). The hour limitations set forth above do not apply to the Emissions Control System Warranty. Refer to the Engine Emission Control Warranty Statement supplied with your product or contained in the engine manufacturer's documentation.

California Proposition 65 Warning Information

What is this warning?

You may see a product for sale that has a warning label like the following:



WARNING: Cancer and Reproductive Harm—www.p65Warnings.ca.gov.

What is Prop 65?

Prop 65 applies to any company operating in California, selling products in California, or manufacturing products that may be sold in or brought into California. It mandates that the Governor of California maintain and publish a list of chemicals known to cause cancer, birth defects, and/or other reproductive harm. The list, which is updated annually, includes hundreds of chemicals found in many everyday items. The purpose of Prop 65 is to inform the public about exposure to these chemicals.

Prop 65 does not ban the sale of products containing these chemicals but instead requires warnings on any product, product packaging, or literature with the product. Moreover, a Prop 65 warning does not mean that a product is in violation of any product safety standards or requirements. In fact, the California government has clarified that a Prop 65 warning "is not the same as a regulatory decision that a product is 'safe' or 'unsafe.'" Many of these chemicals have been used in everyday products for years without documented harm. For more information, go to <https://oag.ca.gov/prop65/faqs-view-all>.

A Prop 65 warning means that a company has either (1) evaluated the exposure and has concluded that it exceeds the "no significant risk level"; or (2) has chosen to provide a warning based on its understanding about the presence of a listed chemical without attempting to evaluate the exposure.

Does this law apply everywhere?

Prop 65 warnings are required under California law only. These warnings are seen throughout California in a wide range of settings, including but not limited to restaurants, grocery stores, hotels, schools, and hospitals, and on a wide variety of products. Additionally, some online and mail order retailers provide Prop 65 warnings on their websites or in catalogs.

How do the California warnings compare to federal limits?

Prop 65 standards are often more stringent than federal and international standards. There are various substances that require a Prop 65 warning at levels that are far lower than federal action limits. For example, the Prop 65 standard for warnings for lead is 0.5 µg/day, which is well below the federal and international standards.

Why don't all similar products carry the warning?

- Products sold in California require Prop 65 labelling while similar products sold elsewhere do not.
- A company involved in a Prop 65 lawsuit reaching a settlement may be required to use Prop 65 warnings for its products, but other companies making similar products may have no such requirement.
- The enforcement of Prop 65 is inconsistent.
- Companies may elect not to provide warnings because they conclude that they are not required to do so under Prop 65; a lack of warnings for a product does not mean that the product is free of listed chemicals at similar levels.

Why does Toro include this warning?

Toro has chosen to provide consumers with as much information as possible so that they can make informed decisions about the products they buy and use. Toro provides warnings in certain cases based on its knowledge of the presence of one or more listed chemicals without evaluating the level of exposure, as not all the listed chemicals provide exposure limit requirements. While the exposure from Toro products may be negligible or well within the "no significant risk" range, out of an abundance of caution, Toro has elected to provide the Prop 65 warnings. Moreover, if Toro does not provide these warnings, it could be sued by the State of California or by private parties seeking to enforce Prop 65 and subject to substantial penalties.