



**Count on it.**

**Parts Catalog**

**91cm (36in) Mid-Size Flail  
Attachment**

Model No. 02720—Serial No. 410300000 and Up



# Ordering Replacement Parts

To order replacement parts, please supply the part number, the quantity, and the description of each part desired.

## Understanding Reference Numbers

Each identified part in an illustration has a reference number. The reference number for a part also appears in the parts list, along with other information about the part.

This catalog uses two special reference number formats, one to indicate parts in a service assembly and another to indicate the quantity of a given part in an illustration.

## Service Assembly Reference Numbers

Parts in service assemblies have reference numbers in the form a:b. The a represents the reference number of the entire service assembly and the b represents a sequential number unique to each part within the service assembly.

For example, a wheel assembly might be identified by reference number 6, the tire by 6:1, the valve by 6:2, and the wheel by 6:3. When you order the assembly identified by reference number 6, you receive all parts identified by reference numbers 6:1, 6:2, and 6:3. However, you may also order any part individually. Reference numbers of this type appear in illustration and in parts lists.

## Reference Numbers Indicating Quantity

In an illustration, if a reference number indicates more than one part, the reference number has the form nX y. The n represents the quantity of the part, the X is the multiplication symbol, and the y represents the reference number.

For example, in an illustration, the reference number 2X 37 means that two of the parts identified by reference number 37 are indicated.

# Contents

Chassis, Cover and Guard Assembly 36 Inch Flail Attachment .....	4
Caster Wheel and Carrier Assembly 36 Inch Flail Attachment .....	6
Rotor Assembly 36 Inch Flail Attachment .....	8
Rotary Drive Assembly .....	10
Top Guard and Side Belt Cover Assembly .....	12
Caster Wheel Assembly .....	14
Guard and Drag Shield Assembly .....	16
Idler Clutch Assembly .....	18
Brake Assembly .....	20

# Chassis, Cover and Guard Assembly 36 Inch Flail Attachment

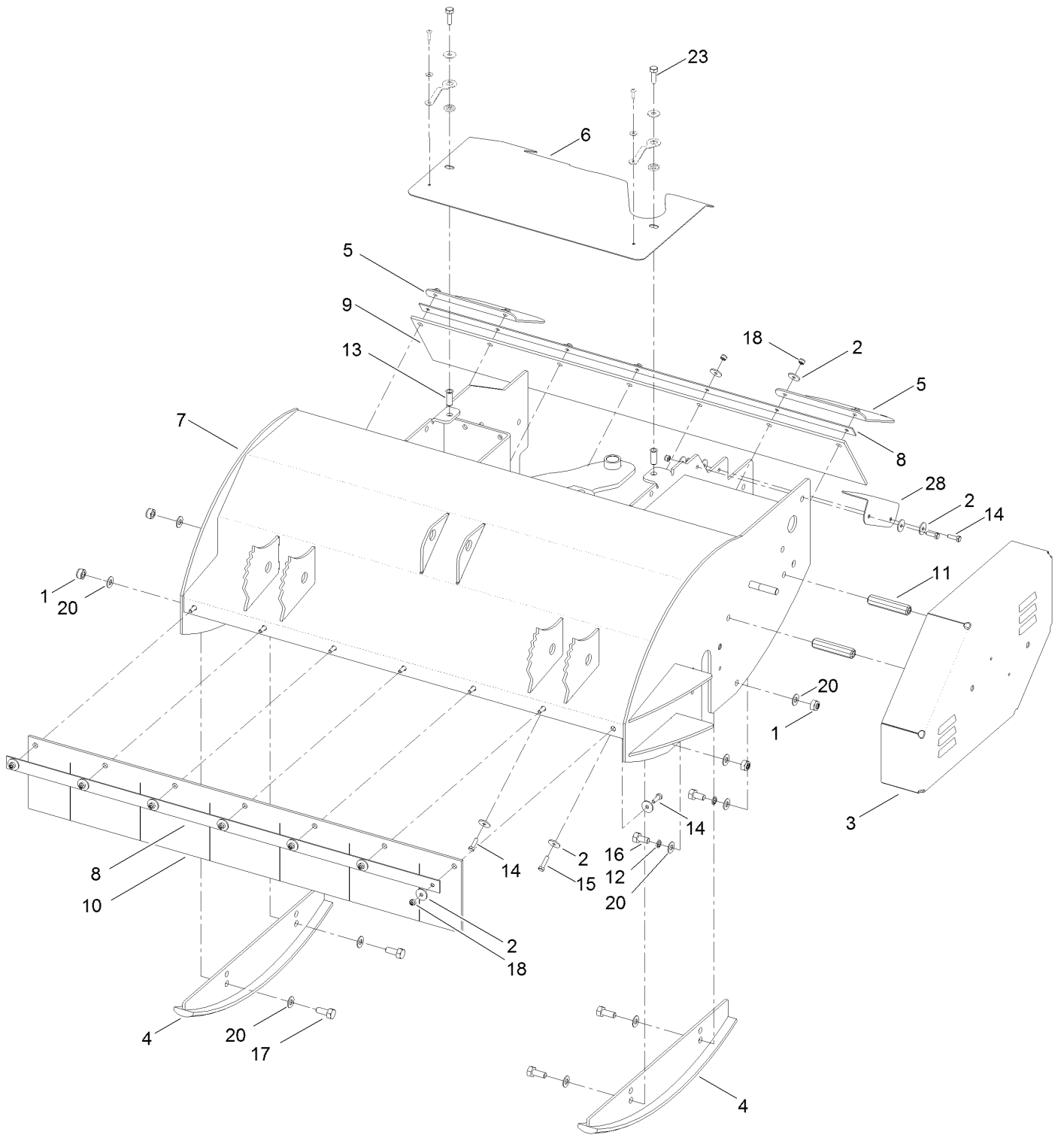

## Chassis, Cover and Guard Assembly 36 Inch Flail Attachment (continued)

<i>Ref.</i>	<i>Part Number</i>	<i>Qty.</i>	<i>Description</i>	<i>Ref.</i>	<i>Part Number</i>	<i>Qty.</i>	<i>Description</i>
1	ZNN1J000U	4	Nut-Hex, NI	12	09480	2	Washer-Lock
2	09263	32	Washer	13	924423	2	Rivet-Blind Bushing
3	111-2382-01	1	Cover-Belt Drive	14	09363	12	Screw-HH
4	111-2385-01	2	Skid-Side	15	09364	4	Screw-HH
5	111-2400-01	2	Guard-Foot	16	09391	4	Screw-HH
6	111-4930-01	1	Guard-Drive, Gearbox	17	09395	4	Screw-HH
7	111-2415-01	1	Frame-Main	18	09438	16	Nut-Nyloc
8	111-2503	2	Bracket-Deflector	20	09479	10	Washer-Plain
9	111-2504	1	Rubber-Deflector	23	03162	2	Screw-HH
10	111-2505	1	Rubber-Deflector Slitted	28	111-4937-01	1	Bracket-Adaptor
11	111-2514	2	Nut-Adjuster				

# Caster Wheel and Carrier Assembly 36 Inch Flail Attachment

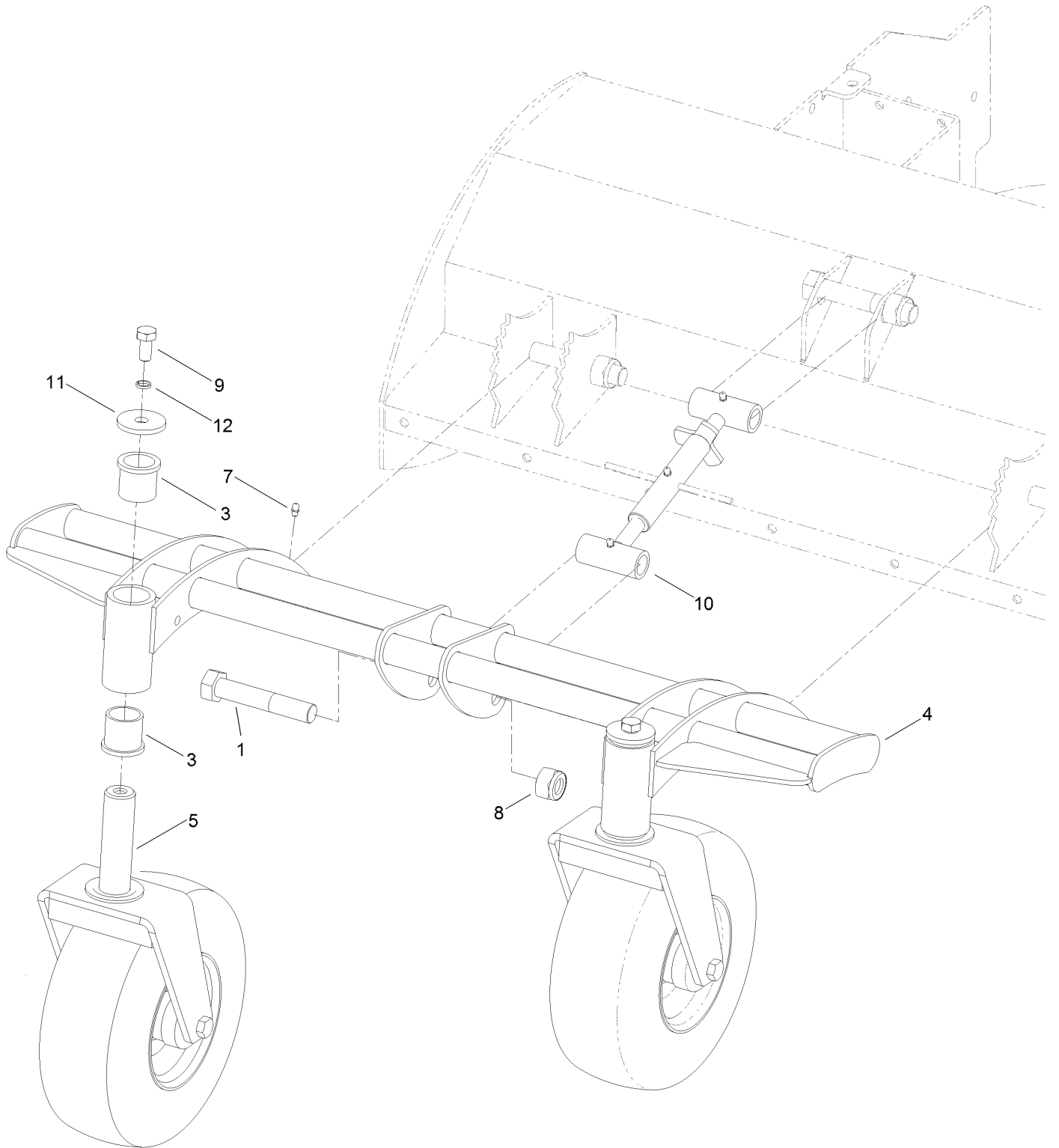

# Caster Wheel and Carrier Assembly 36 Inch Flail Attachment (continued)

<i>Ref.</i>	<i>Part Number</i>	<i>Qty.</i>	<i>Description</i>	<i>Ref.</i>	<i>Part Number</i>	<i>Qty.</i>	<i>Description</i>
1	111-2383	4	Bolt	8	111-2384	4	Nut-Nyloc
3	111-2570	4	Bushing-Caster Wheel	9	09571	2	Screw-HH
4	111-2393-01	1	Carrier-Caster	10	111-2381	1	Turn Buckle ASM
5	111-3370-01	2	Fork-Caster	11	111-2571	2	Washer
7	111-2561	4	Fitting-Grease	12	09599	2	Washer-Lock

# Rotor Assembly 36 Inch Flail Attachment

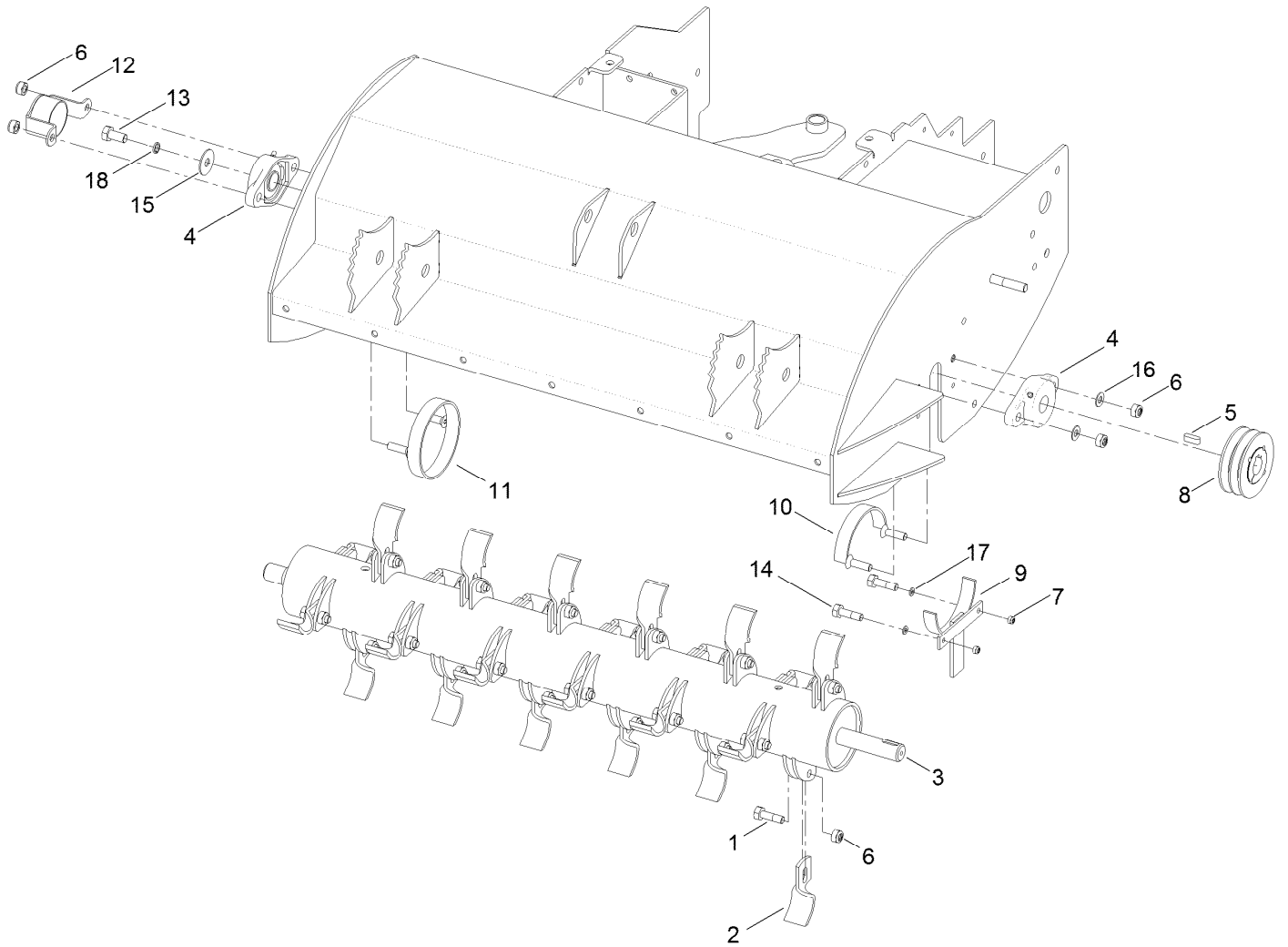



# Rotor Assembly

## 36 Inch Flail Attachment (continued)

<i>Ref.</i>	<i>Part Number</i>	<i>Qty.</i>	<i>Description</i>	<i>Ref.</i>	<i>Part Number</i>	<i>Qty.</i>	<i>Description</i>
1	111-7096	24	Screw-HH	10	111-2445	1	Collar-Rotor End, LH Upper
2	111-9287	24	Knife-Flail	11	111-2416	1	Collar-Rotor End, RH Collar
3	111-2429-03	1	Flail Rotor ASM	12	111-2419	1	Cover-End, Rotor
4	111-2444	2	Bearing-Flange	13	09571	1	Screw-HH
5	111-2480	1	Key	14	09363	2	Screw-HH
6	ZNN1J000U	28	Nut-Hex, NI	15	09283	1	Washer
7	09438	2	Nut-Nyloc	16	09479	2	Washer-Plain
8	111-2412	1	Pulley-V	17	09472	2	Washer-Plain
9	111-2447	1	Collar-Rotor End, LH Lower	18	09599	1	Washer-Lock

# Rotary Drive Assembly

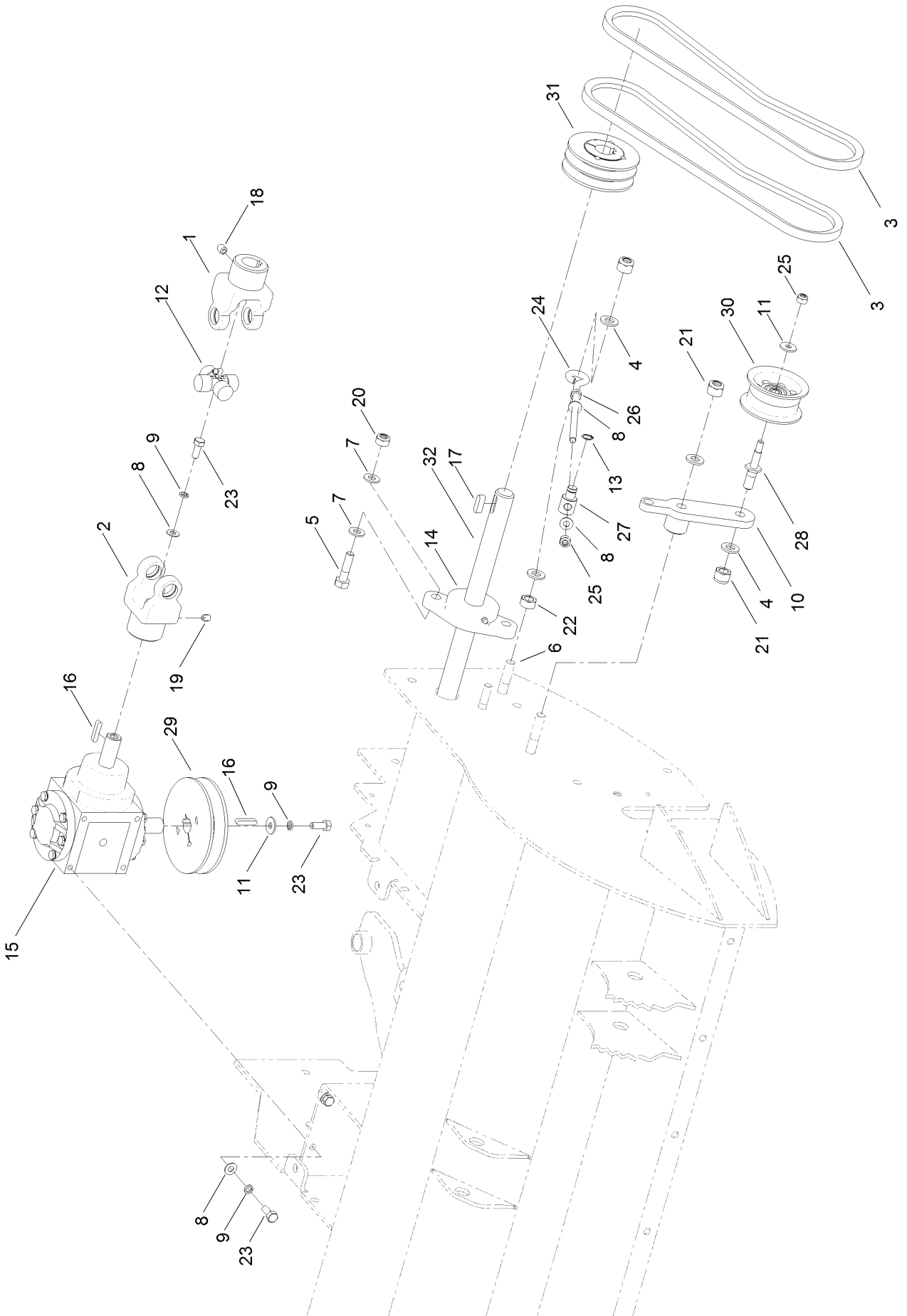

## Rotary Drive Assembly (continued)

<i>Ref.</i>	<i>Part Number</i>	<i>Qty.</i>	<i>Description</i>	<i>Ref.</i>	<i>Part Number</i>	<i>Qty.</i>	<i>Description</i>
1	111-2433	1	Yoke-PTO	17	111-2480	2	Key
2	111-2432	1	Yoke-PTO	18	111-3085	1	Screw-Grub, Cup Point
3	111-2476	2	Belt	19	111-3084	1	Screw-Grub, Cup Point
4	HY09485	4	Washer-Plain	20	ZNN1J000U	2	Nut-Hex, NI
5	09611	2	Bolt-HH	21	ZNN1L000U	3	Nut-Nyloc
6	09552	1	Screw-HH	22	09454	1	Nut-Hex
7	ZWQ1J000U	4	Washer-Plain	23	09368	6	Screw-HH
8	09475	7	Washer	24	111-2469	1	Rod-Eye, Threaded
9	03469	6	Washer-Spring	25	09441	2	Nut-Hex, NI
10	111-2456	1	Bracket-Pulley, Idler	26	ZNH1H000U	1	Nut-Hex
11	09267	2	Washer-Plain	27	111-2460	1	Pivot-Boss
12	111-2431	1	Joint-Universal, PTO	28	111-2459	1	Pivot-Bracket, Idler
13	950940	1	Circlip-External	29	111-2473	1	Pulley-Gearbox
14	111-2444	1	Bearing-Flange	30	111-2455	1	Pulley-Idler
15	111-2411	1	Gearbox	31	111-2412	1	Pulley-V
15:99	134-3781	1	Kit-Seal ●	32	111-2501-03	1	Rod-Drive Shaft
16	111-2481	2	Key				

● Not illustrated

# Top Guard and Side Belt Cover Assembly

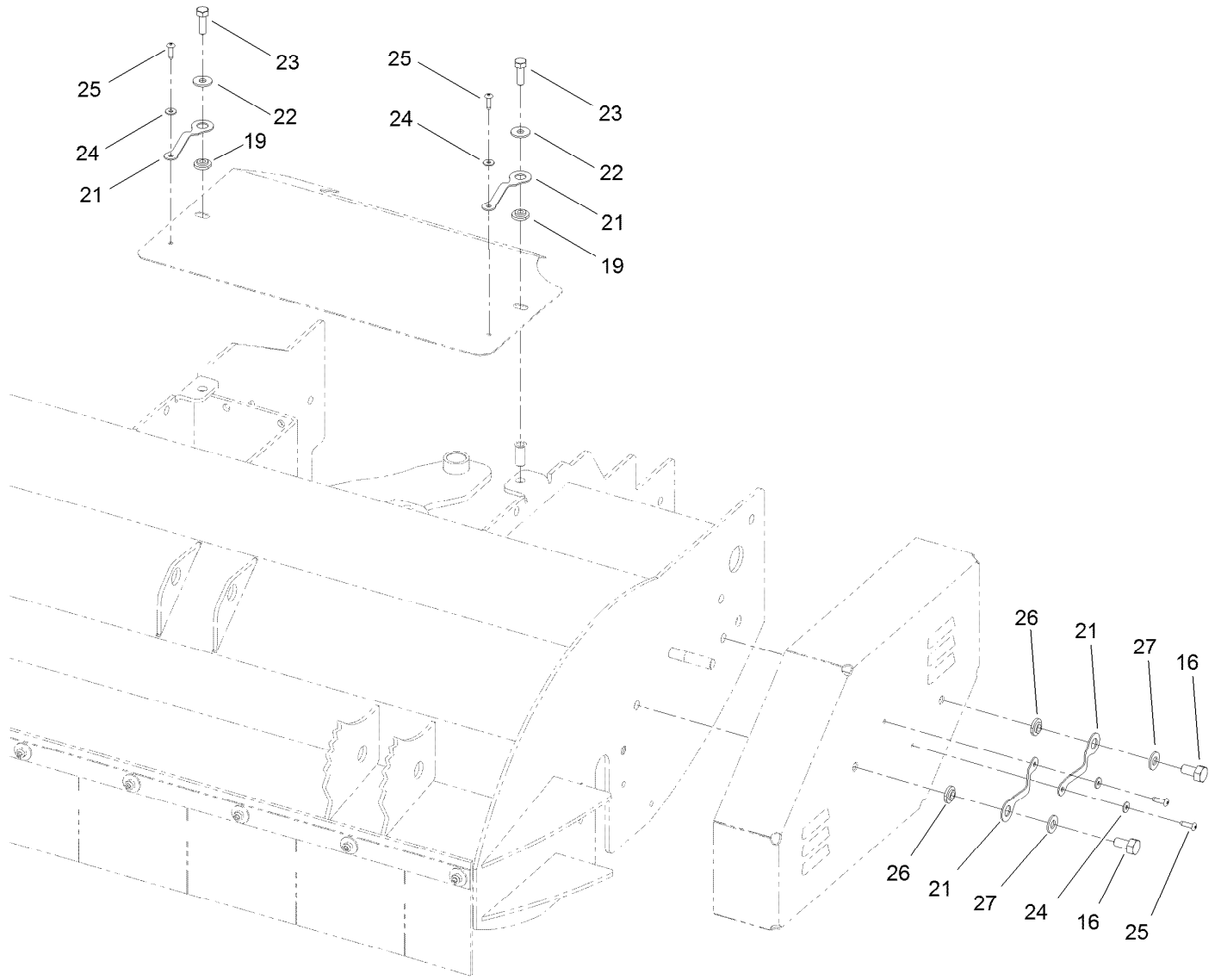

# Top Guard and Side Belt Cover Assembly (continued)

<i>Ref.</i>	<i>Part Number</i>	<i>Qty.</i>	<i>Description</i>	<i>Ref.</i>	<i>Part Number</i>	<i>Qty.</i>	<i>Description</i>
16	09391	2	Screw-HH	24	09257	4	Washer
19	111-3697	2	Nut-Retainer	25	09320	4	Rivet
21	117-8339	4	Lanyard-3 Inch	26	111-3720	2	Nut-Retainer
22	09267	2	Washer-Plain	27	ZWQ1J000U	2	Washer-Plain
23	03162	2	Screw-HH				

# Caster Wheel Assembly

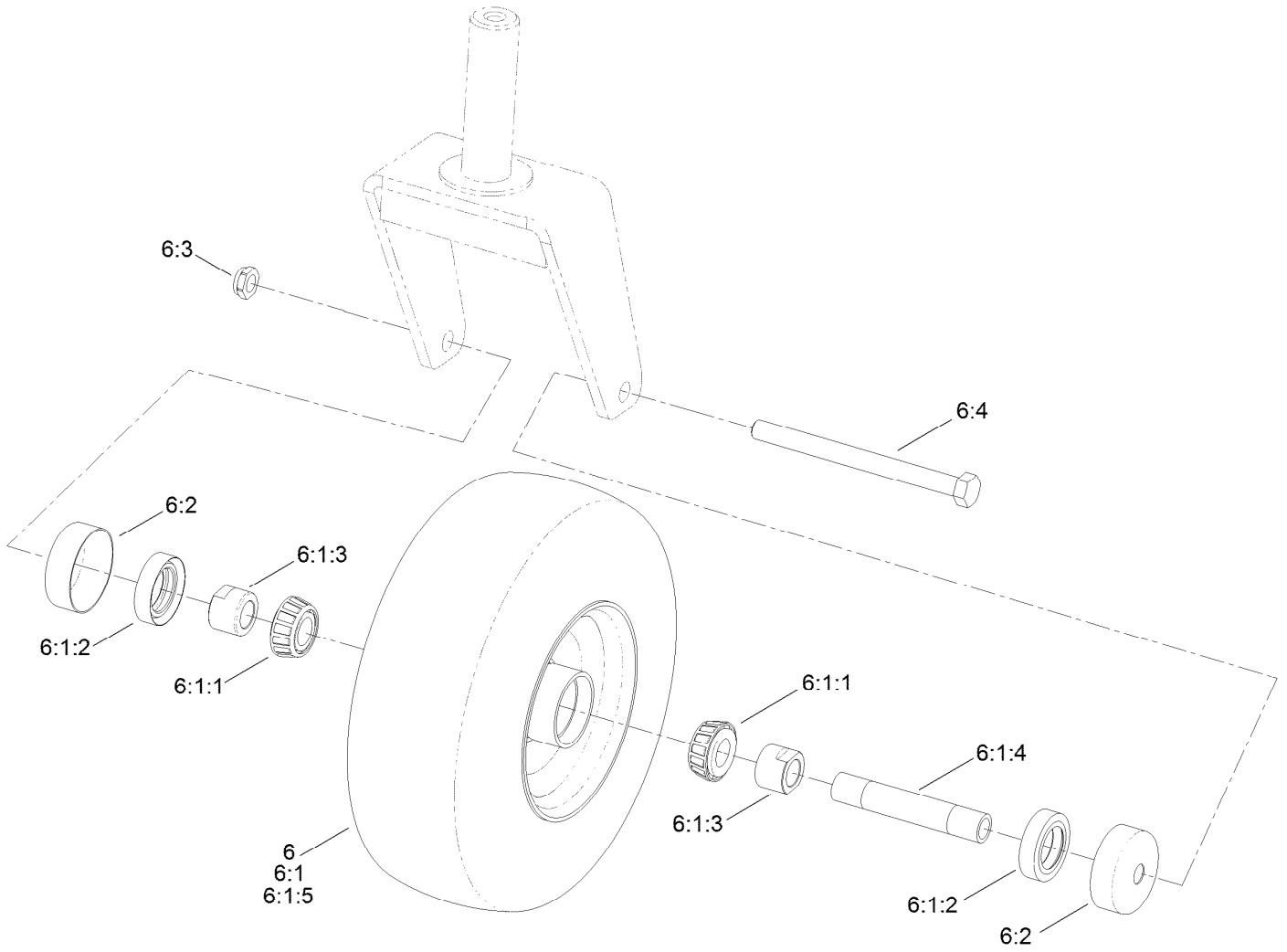

## Caster Wheel Assembly (continued)

<i>Ref.</i>	<i>Part Number</i>	<i>Qty.</i>	<i>Description</i>	<i>Ref.</i>	<i>Part Number</i>	<i>Qty.</i>	<i>Description</i>
6	112-3810	2	Wheel/Tire And Bearing ASM	6:1:4	126-5359	1	Caster Axle ASM
6:1		1	Wheel And Bearing ASM ●	6:1:5	110-9965	1	Wheel And Tire ASM
6:1:1	1-633585	2	Bearing-Cone, Taper	6:2	103-2768	2	Guard-Seal
6:1:2	103-0063	2	Seal-Caster	6:3	3296-45	1	Nut-Hex
6:1:3	103-3051	1	Spacer-Nut ■	6:4	325-20	1	Screw-HH

● Not serviced separately

■ Use Pro-Lock, Nut Type (P/N 1-840022, .5ml tube) on spacer nut

# Guard and Drag Shield Assembly

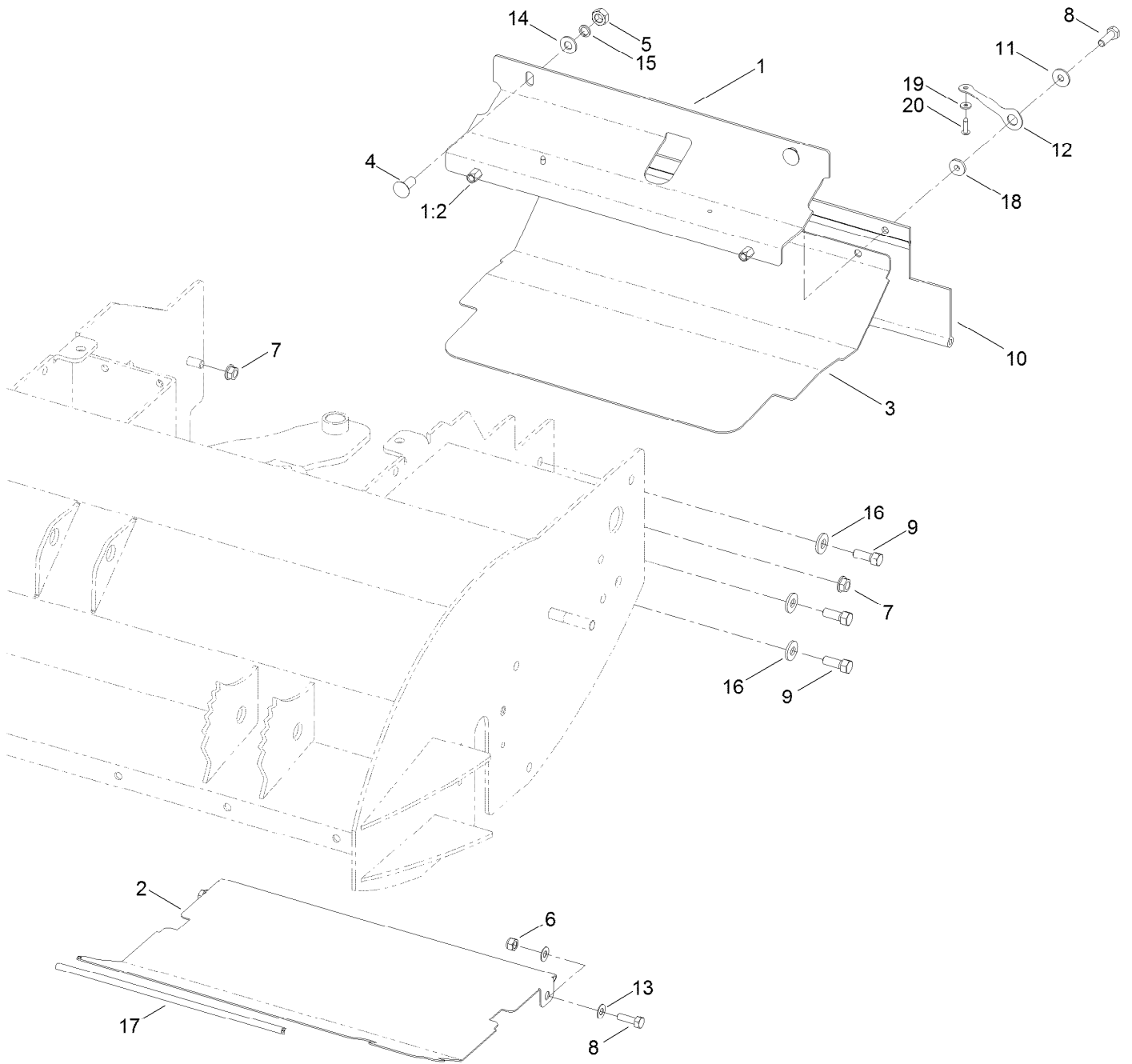



## Guard and Drag Shield Assembly (continued)

<i>Ref.</i>	<i>Part Number</i>	<i>Qty.</i>	<i>Description</i>	<i>Ref.</i>	<i>Part Number</i>	<i>Qty.</i>	<i>Description</i>
1	111-1986	1	Guard-Drive	10	103-2056	1	Shield-Drag
1:2	111-7683	2	Nut-Rivet	11	09267	2	Washer-Plain
2	111-2525-01	1	Guard-Center Discharge Flail	12	117-8339	2	Lanyard-3 Inch
3	111-1655-01	1	Guard-Underside	13	09475	4	Washer
4	15-11-003	2	Bolt-CARR	14	ZWQ1J000U	2	Washer-Plain
5	09449	2	Nut	15	09480	2	Washer-Lock
6	09441	2	Nut-Hex, NI	16	98-5975	8	Washer-Belleville
7	3290-357	8	Nut-HSF	17	305128	1	Strip-Protection
8	03162	4	Screw-HH	18	111-3697	2	Nut-Retainer
9	HY103653	8	Screw-HH	19	09257	2	Washer
				20	09320	2	Rivet

# Idler Clutch Assembly

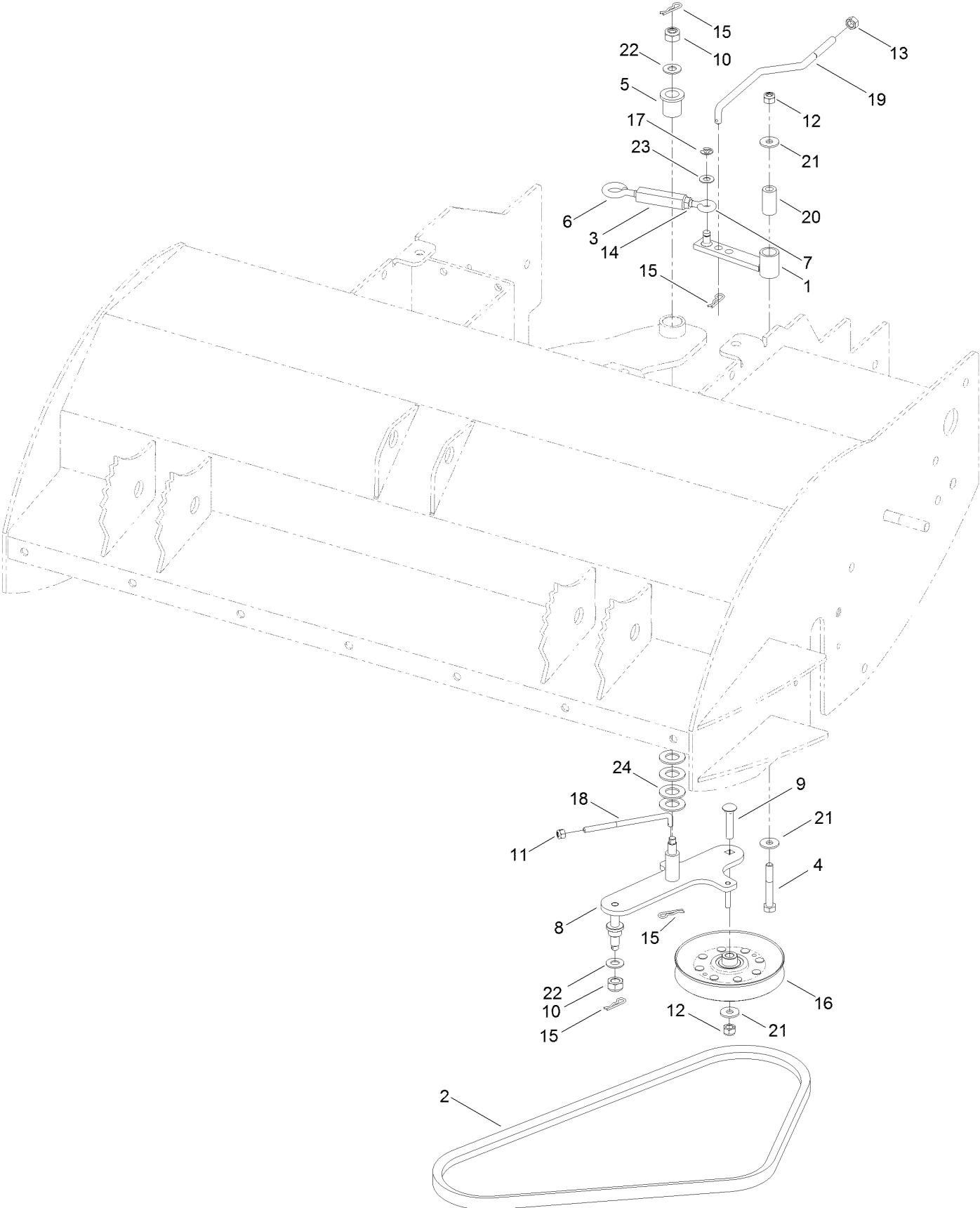

## Idler Clutch Assembly (continued)

<i>Ref.</i>	<i>Part Number</i>	<i>Qty.</i>	<i>Description</i>	<i>Ref.</i>	<i>Part Number</i>	<i>Qty.</i>	<i>Description</i>
1	111-2990	1	Arm-Assist	13	09207	1	Nut
2	111-2655	1	Belt-V	14	32128-20	1	Nut-HF
3	1-303236	1	Body-Turnbuckle	15	1-806003	4	Pin-Cotter
4	09565	1	Screw-HH	16	111-2464	1	Pulley-Idler Clutch
5	953868	1	Bushing-Flange, Oilite	17	32120-35	1	Ring-Retaining, EXT
6	1-303348	1	Eyebolt-Thread, LH	18	111-2977	1	Rod-Brake
7	1-303238	1	Eyebolt-Thread, RH	19	111-2474	1	Rod-Linkage, Drive
8	111-2657	1	Idler-Clutch	20	1-403179	1	Tube-Pivot
9	09379	1	Bolt-Coach	21	09267	3	Washer-Plain
10	ZNN1J000U	2	Nut-Hex, NI	22	09479	2	Washer-Plain
11	09544	1	Nut-Nyloc	23	09475	1	Washer
12	09441	2	Nut-Hex, NI	24	ZWP1P000U	4	Washer-Plain

# Brake Assembly

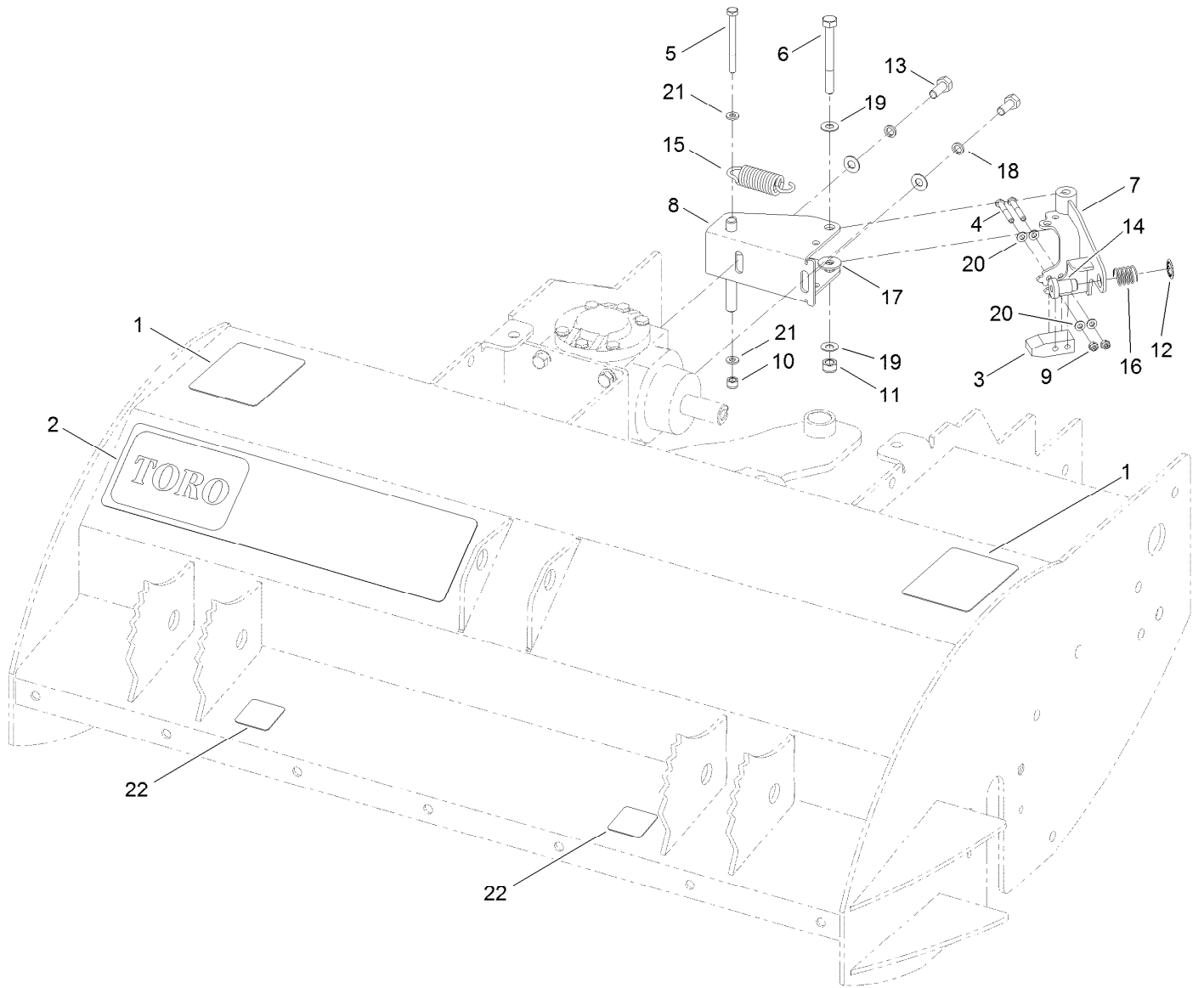

## Brake Assembly (continued)

<i>Ref.</i>	<i>Part Number</i>	<i>Qty.</i>	<i>Description</i>	<i>Ref.</i>	<i>Part Number</i>	<i>Qty.</i>	<i>Description</i>
1	139-5557	2	Decal-Danger, CE	12	1-323748	1	Ring-Push On
2	111-2992	1	Decal	13	09368	2	Screw-HH
3	212226	1	Block-Brake	14	1-323746	1	Spacer-Flanged
4	ZBH1E035U	2	Bolt	15	212227	1	Spring-Tension
5	09703	1	Bolt-HH	16	1-323747	1	Spring-Compression
6	ZBH1H075U	1	Bolt	17	09267	1	Washer-Plain
7	111-2980	1	Brake-Arm	18	03469	2	Washer-Spring
8	111-2985	1	Bracket-Mount, Brake	19	09475	4	Washer
9	09430	2	Nut-Nyloc	20	09470	4	Washer
10	09544	1	Nut-Nyloc	21	09472	2	Washer-Plain
11	09441	1	Nut-Hex, NI	22	320006	2	Decal-HOC

**Notes:**

**Notes:**



**Count on it.**