



Count on it.

Operator's Manual

**Greensmaster® eTriFlex 3370
Traction Unit**

Model No. 04590—Serial No. 408000000 and Up

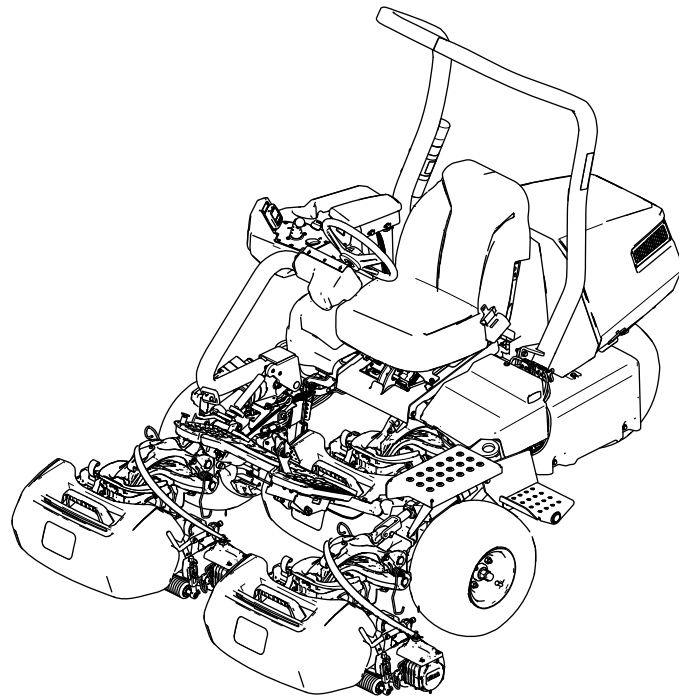

This product complies with all relevant European directives; for details, please see the separate product specific Declaration of Conformity (DOC) sheet.

⚠ WARNING

**CALIFORNIA
Proposition 65 Warning**

The power cord on this product contains lead, a chemical known to the State of California to cause birth defects or other reproductive harm. Wash hands after handling.

Battery posts, terminals, and related accessories contain lead and lead compounds, chemicals known to the State of California to cause cancer and reproductive harm. Wash hands after handling.

Use of this product may cause exposure to chemicals known to the State of California to cause cancer, birth defects, or other reproductive harm.

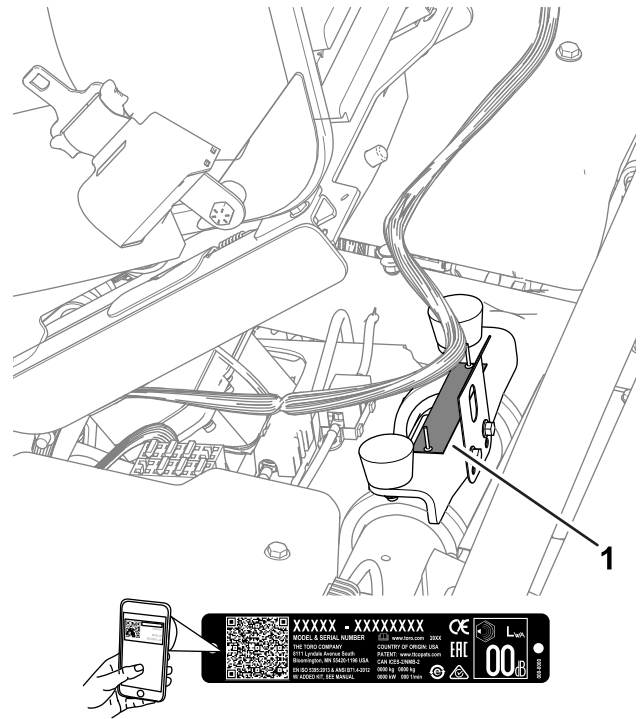

Figure 1

g279286

1. Model and serial number location

Model No. _____

Serial No. _____

Introduction

This machine is a ride-on, reel-blade greens mower intended to be used by professional, hired operators in commercial applications. It is primarily designed for cutting grass on well-maintained turf. Using this product for purposes other than its intended use could prove dangerous to you and bystanders.

Read this information carefully to learn how to operate and maintain your product properly and to avoid injury and product damage. You are responsible for operating the product properly and safely.

Visit www.Toro.com for more information, including safety tips, training materials, accessory information, help finding a dealer, or to register your product.

Whenever you need service, genuine Toro parts, or additional information, contact an authorized Toro distributor and have the model and serial numbers of your product ready. [Figure 1](#) identifies the location of the model and serial numbers on the product. Write the numbers in the space provided.

Important: With your mobile device, you can scan the QR code on the serial number decal (if equipped) to access warranty, parts, and other product information.

This manual identifies potential hazards and has safety messages identified by the safety-alert symbol ([Figure 2](#)), which signals a hazard that may cause serious injury or death if you do not follow the recommended precautions.



Figure 2

Safety-alert symbol

g000502

This manual uses 2 words to highlight information. **Important** calls attention to special mechanical information and **Note** emphasizes general information worthy of special attention.

Contents

Safety	4	Recommended Maintenance Schedule(s)	37
General Safety	4	Daily Maintenance Checklist	38
Safety and Instructional Decals	4	Pre-Maintenance Procedures	38
Setup	8	Raising the Machine	38
1 Installing the Roll Bar	9	Raising the Hood	40
2 Installing the Seat	9	Electrical System Maintenance	40
3 Installing the Service Decal	9	Electrical System Safety	40
4 Installing the Steering Wheel	10	Disconnecting or Connecting Power to the	
5 Installing the Grass-Basket Hooks	10	Machine	40
6 Installing the Cutting Units	10	Locating the Fuses	41
7 Connecting the Main-Power		Servicing the Batteries	43
Connectors	11	Maintaining the Battery Charger	43
8 Adjusting the Machine Settings	12	Drive System Maintenance	44
9 Installing the CE Decals	12	Checking the Tire Pressure	44
10 Reducing the Tire Pressure	13	Checking the Torque of the Wheel	
11 Mounting the Battery Charger on a		Nuts	44
Wall	13	Changing the Traction-Motor-Gearbox	
12 Charging the Batteries	13	Fluid	44
Product Overview	14	Brake Maintenance	46
Controls	14	Adjusting the Brakes	46
InfoCenter	16	Cutting Unit Maintenance	46
Specifications	20	Blade Safety	46
Attachments/Accessories	21	Installing and Removing the Cutting	
Before Operation	22	Units	46
Before Operation Safety	22	Checking the Reel-to-Bedknife Contact	49
Identifying the Cutting Units	22	Backlapping the Cutting Units	49
Using the InfoCenter to Adjust the Machine		Storage	50
Settings	22	Storage Safety	50
Understanding the InfoCenter Dialog		Preparing the Machine for Storage	50
Messages	25	Battery Storage Requirements	50
Tilting the Steering Wheel	25	Storing the Charger	51
Performing Daily Maintenance	26	Troubleshooting	52
During Operation	26		
During Operation Safety	26		
Breaking in the Machine	27		
Turning On the Machine	27		
Checking the Machine after Turning On the			
Machine	27		
Understanding the Safety-Interlock			
System	27		
Driving the Machine without Mowing	28		
Mowing the Green	28		
Monitoring the Battery-System Charge			
Level	30		
Shutting Off the Machine	30		
After Operation	30		
After Operation Safety	30		
Inspecting and Cleaning after Mowing	32		
Hauling the Machine	32		
Towing the Machine	33		
Maintaining the Lithium-Ion Batteries	34		
Transporting the Lithium-Ion Batteries	34		
Understanding the Lithium-Ion Battery			
Charger	35		
Maintenance	37		
Maintenance Safety	37		

Safety

This machine has been designed in accordance with EN ISO 5395 (when you complete the setup procedures) and ANSI B71.4-2017.

General Safety

This product is capable of amputating hands and feet and of throwing objects.

- Read and understand the contents of this *Operator's Manual* before turning on the machine.
- Use your full attention while operating the machine. Do not engage in any activity that causes distractions; otherwise, injury or property damage may occur.
- Do not put your hands or feet near moving components of the machine.
- Do not operate the machine without all guards and other safety protective devices in place and functioning properly on the machine.
- Keep bystanders and children out of the operating area. Never allow children to operate the machine.
- Shut off the machine, remove the key, and wait for all movement to stop before you leave the operator's position. Allow the machine to cool before adjusting, servicing, cleaning, or storing it.

Improperly using or maintaining this machine can result in injury. To reduce the potential for injury, comply with these safety instructions and always pay attention to the safety-alert symbol , which means Caution, Warning, or Danger—personal safety instruction. Failure to comply with these instructions may result in personal injury or death.

Safety and Instructional Decals



Safety decals and instructions are easily visible to the operator and are located near any area of potential danger. Replace any decal that is damaged or missing.

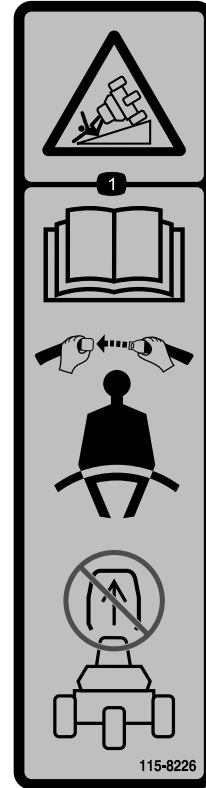

115-8226

decal115-8226

1. Tipping hazard—read the *Operator's Manual*; wear a seatbelt; do not remove the roll bar.

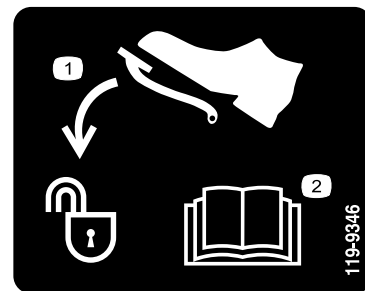

119-9346

decal119-9346

1. Press the pedal to unlock.
2. Read the *Operator's Manual* for more information.

WARNING: Cancer and Reproductive Harm - www.P65Warnings.ca.gov.
For more information, please visit www.ttcocaprop65.com

133-8061

133-8061

decal133-8061

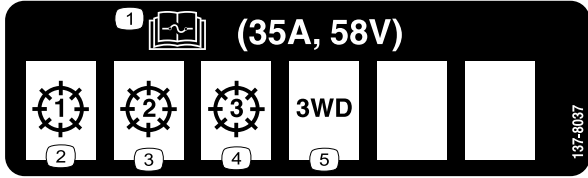

137-8037

decal137-8037

1. Read the *Operator's Manual* for fuse information.
2. Cutting unit—1
3. Cutting unit—2
4. Cutting unit—3
5. 3-wheel-drive kit

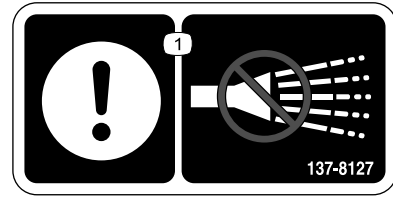

137-8127

decal137-8127

1. Attention—do not spray with high-pressure water.

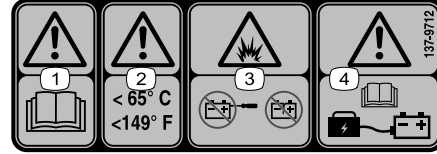

137-9712

decal137-9712

1. Warning—read the *Operator's Manual*.
2. Warning—keep at temperatures below 65° C (149° F).
3. Explosion hazard—do not open the battery; do not use a damaged battery.
4. Warning—read the *Operator's Manual* for battery charging information.

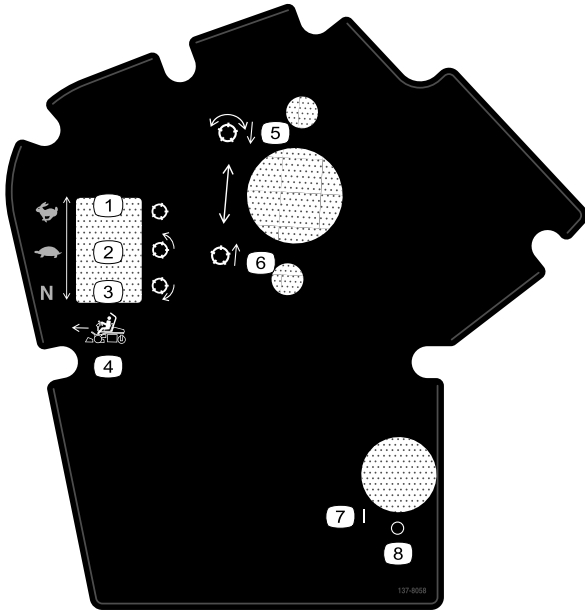

137-8058

decal137-8058

1. Traction speed—fast; reel—transport
2. Traction speed—slow; reel—mow
3. Traction speed—neutral; reel—backlap
4. Forward function controls
5. Lower and engage the reels.
6. Raise and disengage the reels.
7. On
8. Off

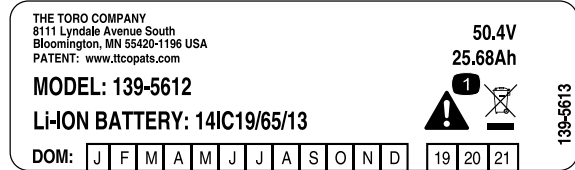

139-5613

decal139-5613

1. Warning—do not discard.

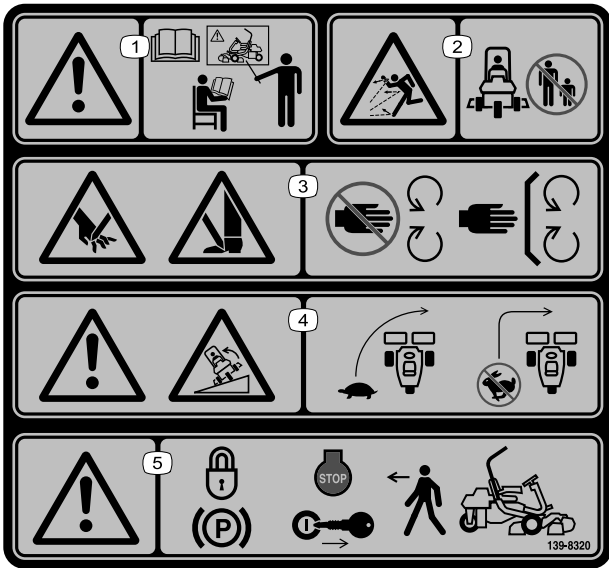

139-8320

decal139-8320

1. Warning—all operators should read the *Operator's Manual* and be trained before operating the machine.
2. Thrown object hazard—keep bystanders away.
3. Cutting/dismemberment hazard of hand; cutting/dismemberment hazard of foot—stay away from moving parts; keep all guards and shields in place.
4. Warning; tipping hazard—drive slowly when turning; do not turn sharply while traveling fast.
5. Warning—engage the parking brake, shut off the engine, and remove the key before leaving the machine.

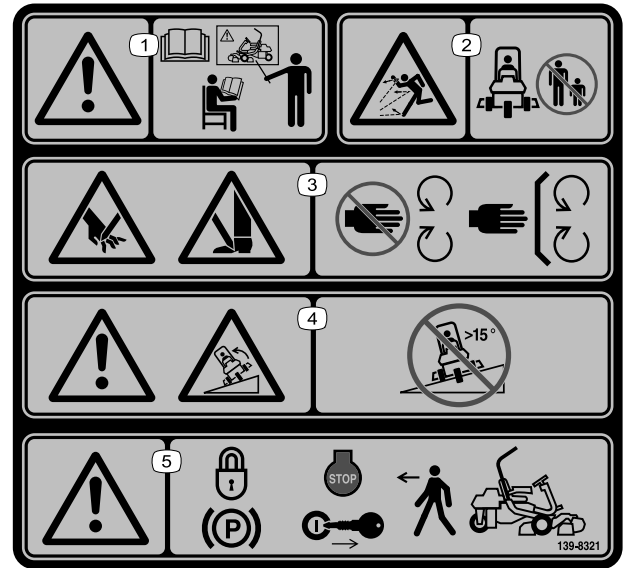

139-8321

decal139-8321

Note: This machine complies with the industry standard stability test in the static lateral and longitudinal tests with the maximum recommended slope indicated on the decal. Review the instructions for operating the machine on slopes in the *Operator's Manual* as well as the conditions in which you would operate the machine to determine whether you can operate the machine in the conditions on that day and at that site. Changes in the terrain can result in a change in slope operation for the machine.

1. Warning—all operators should read the *Operator's Manual* and be trained before operating the machine.
2. Thrown object hazard—keep bystanders away.
3. Cutting/dismemberment hazard of hand; cutting/dismemberment hazard of foot—stay away from moving parts; keep all guards and shields in place.
4. Warning; tipping hazard—do not use on slopes greater than 15°.
5. Warning—engage the parking brake, shut off the engine, and remove the key before leaving the machine.

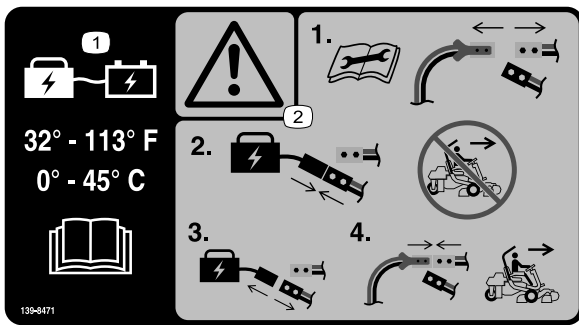

139-8471

decal139-8471

1. Keep the battery at temperatures between 0° to 45° C (32° to 113° F) when charging; read the *Operator's Manual*.
2. Warning—read the *Operator's Manual* before performing maintenance, disconnect the main power connectors, connect the battery to the charging connector and do not operate the machine, disconnect the battery from the charging connector, and connect the main power connectors to operate the machine.



139-8554

decal139-8554

1. Warning—Use Toro 04012, Delta-Q 951-0002, or equivalent charger only; Store machine indoors.

GREENSMMASTER 3370 eTriFlex **QUICK REFERENCE AID**  **SEE OPERATOR'S MANUAL**

CHECK/SERVICE (daily)

1. INTERLOCK SYSTEM:

- 1a. SEAT INTERLOCK
- 1b. PARKING BRAKE INTERLOCK
- 1c. NEUTRAL SWITCH
- 1d. MOW SENSOR

2. TIRE PRESSURE (12 - 16 psi)

3. WHEEL NUT TORQUE (70-90 FT LBS)

FLUID SPECIFICATIONS / CHANGE INTERVALS

See operator's manual for initial change	FLUID TYPE	CAPACITY		CHANGE INTERVALS	
		L	QTS.	FLUID	FILTER
A. TRACTION MOTORS	SAE 80W90	0.8	0.8	800 HRS.	—

137-8052

decal137-8052



137-9713

decal137-9713

1. Warning—read the *Operator's Manual*.
2. Warning—keep out of the rain and other wet conditions.
3. Warning—do not touch the hot surface.
4. Warning—do not open the battery; do not use a damaged battery.
5. Explosion hazard—avoid sparks; no fire, open flames, or smoking.
6. Asphyxiation hazard, poisonous fumes or toxic gases—do not charge the battery in an enclosed space.
7. Electric shock hazard—do not perform maintenance on the battery.

Setup

Loose Parts

Use the chart below to verify that all parts have been shipped.

Procedure	Description	Qty.	Use
1	Roll bar assembly	1	Install the roll bar.
	Hex-head bolt (3/8 x 1-1/2 inch)	8	
	Nut (3/8 inch)	8	
2	Seat Kit (order separately; contact your authorized Toro distributor)	1	Install the seat.
3	Service decal (Part Number 137-8052)	1	Install the service decal.
4	Steering wheel	1	Install the steering wheel.
	Cap	1	
	Washer	1	
	Locknut	1	
5	Grass-basket hook	6	Install the grass-basket hooks.
	Flange bolts	12	
6	Cutting unit (order separately; contact your authorized Toro distributor)	3	Install the cutting units.
	Grass basket	3	
	Electric counterweight	3	
	Capscrew	6	
	O-ring	3	
7	No parts required	–	Connect the main-power connectors.
8	No parts required	–	Adjust the machine settings.
9	Production year decal	1	Install the CE decals (if required).
	CE warning decal (Part Number 139-8321)	1	
	CE mark decal (Part Number 93-7252)	1	
10	No parts required	–	Reduce the tire pressure.
11	No parts required	–	Mount the battery charger on a wall (optional).
12	No parts required	–	Charge the batteries.

1

Installing the Roll Bar

Parts needed for this procedure:

1	Roll bar assembly
8	Hex-head bolt (3/8 x 1-1/2 inch)
8	Nut (3/8 inch)

Procedure

1. Remove the top crate support from the crate.
2. Remove the roll bar from the crate.
3. Use 8 hex-head bolts (3/8 x 1-1/2 inch) and 8 nuts (3/8 inch) to secure the roll bar to the roll-bar brackets on each side of the machine (Figure 3).

Note: Have an assistant help you to position and secure the roll bar to the machine.

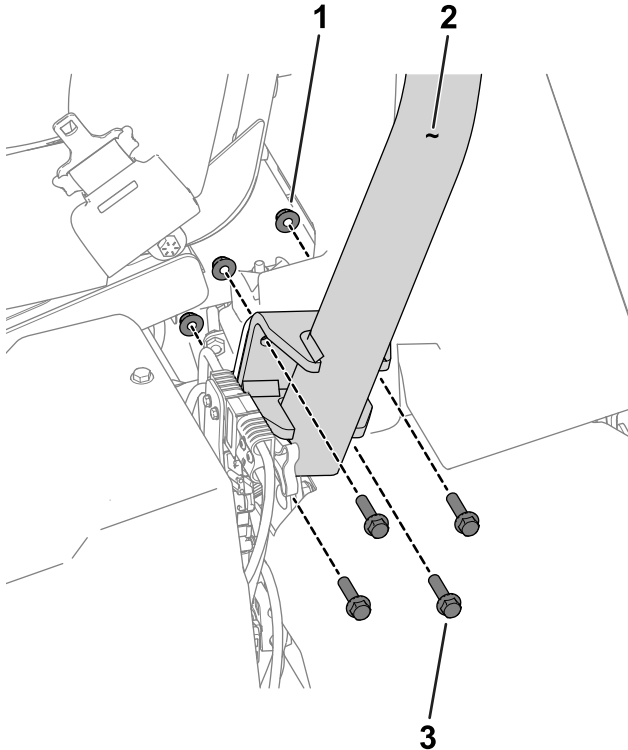

Figure 3

Left side of the machine shown

g277676

- | | |
|-------------------|-------------------------------------|
| 1. Nut (3/8 inch) | 3. Hex-head bolt (3/8 x 1-1/2 inch) |
| 2. Roll bar | |
-
4. Torque the fasteners to 51 to 65 N·m (38 to 48 ft-lb).

2

Installing the Seat

Parts needed for this procedure:

1	Seat Kit (order separately; contact your authorized Toro distributor)
---	---

Procedure

Acquire the Seat Kit (contact your authorized Toro distributor) and refer to the kit *Installation Instructions* to install the seat.

3

Installing the Service Decal

Parts needed for this procedure:

1	Service decal (Part Number 137-8052)
---	--------------------------------------

Procedure

Install the service decal (Part Number 137-8052) to the seat; refer to Figure 4 for the premium seat (Model 04729) or Figure 5 for the standard seat (Model 04508).

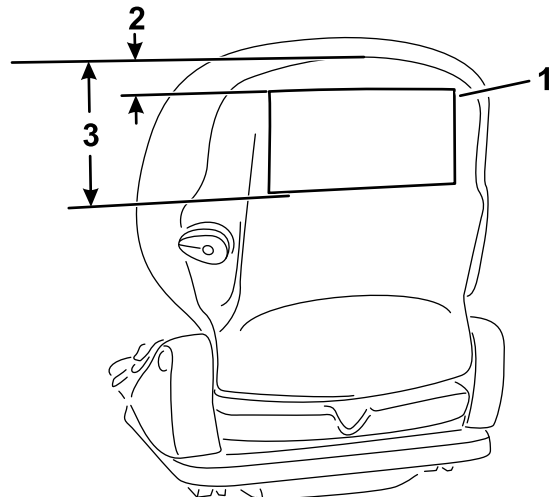

Figure 4

Premium Seat (Model 04729)

g277096

- | | |
|--------------------|-------------------------|
| 1. Service decal | 3. 18.5 cm (6.5 inches) |
| 2. 2.5 cm (1 inch) | |

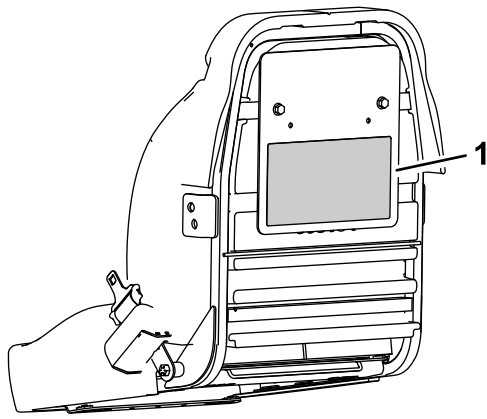

Figure 5
Standard Seat (Model 04508)

g277097

1. Service decal

2. Install the wheel to the steering shaft using the washer and locknut (Figure 6).
3. Torque the locknut to 27 to 35 N·m (20 to 26 ft-lb).
4. Install the cap to the wheel (Figure 6).

5

Installing the Grass-Basket Hooks

Parts needed for this procedure:

6	Grass-basket hook
12	Flange bolts

Procedure

Use 12 flange bolts to install 6 grass-basket hooks onto the ends of the suspension-arm bars (Figure 7).

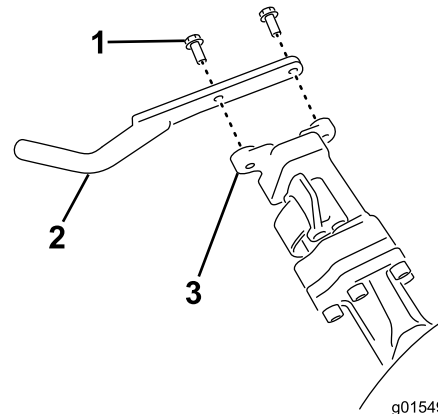

g015492

g015492

Figure 7

1. Flange bolt
2. Grass-basket hook
3. Suspension-arm bar

4

Installing the Steering Wheel

Parts needed for this procedure:

1	Steering wheel
1	Cap
1	Washer
1	Locknut

Procedure

1. Apply anti-seize compound to the steering shaft (shown in Figure 6).

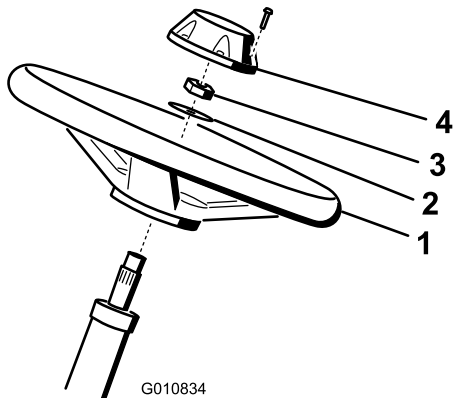

G010834

g010834

Figure 6

1. Steering shaft
2. Steering wheel
3. Washer
4. Locknut
5. Cap

6

Installing the Cutting Units

Parts needed for this procedure:

3	Cutting unit (order separately; contact your authorized Toro distributor)
3	Grass basket
3	Electric counterweight
6	Capscrew
3	O-ring

Procedure

1. Prepare the cutting units for installation; refer to your cutting unit *Operator's Manual*.
2. Apply grease to the inside spline of the drive coupler.
3. Install an O-ring to each reel motor as shown in [Figure 8](#).

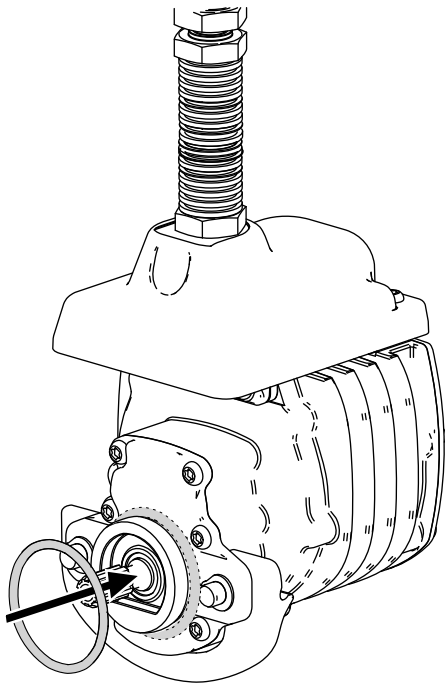

Figure 8

g256064

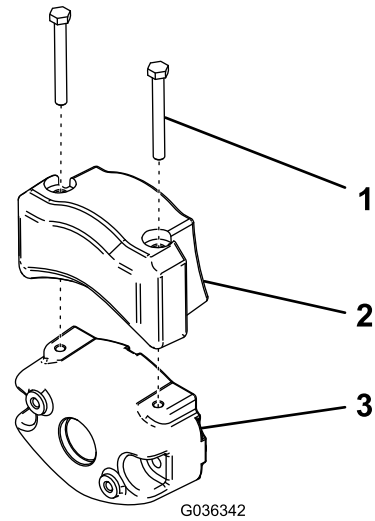

Figure 9

G036342

g036342

1. Capscrew
2. Electrical counterweight
3. Existing counterweight

5. Install the cutting units; refer to [Installing the Cutting Units \(page 47\)](#).
6. Install each grass basket onto the grass-basket hooks.

7

Connecting the Main-Power Connectors

No Parts Required

Procedure

Plug in the main-power connectors located near the base of the roll bar on the left side of the machine ([Figure 10](#)).

4. Secure the electrical counterweight to the existing counterweight with 2 capscrews as shown in [Figure 9](#).

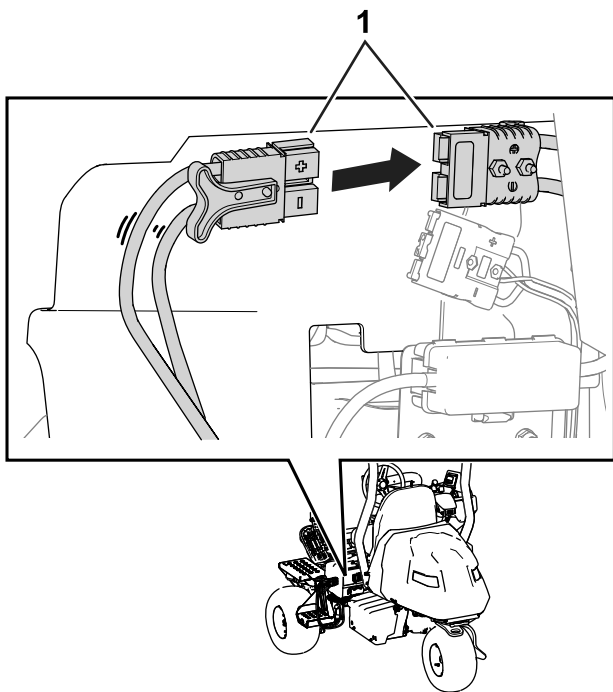

Figure 10

g293202

1. Main-power connectors

9

Installing the CE Decals

If Required (CE-Compliant Countries)

Parts needed for this procedure:

1	Production year decal
1	CE warning decal (Part Number 139-8321)
1	CE mark decal (Part Number 93-7252)

Procedure

If you use this machine in a country that complies to CE standards, install the following decals:

- **Production year decal** and **CE mark decal**: apply the decals on the frame tube below the seat and serial plate; refer to [Figure 11](#).

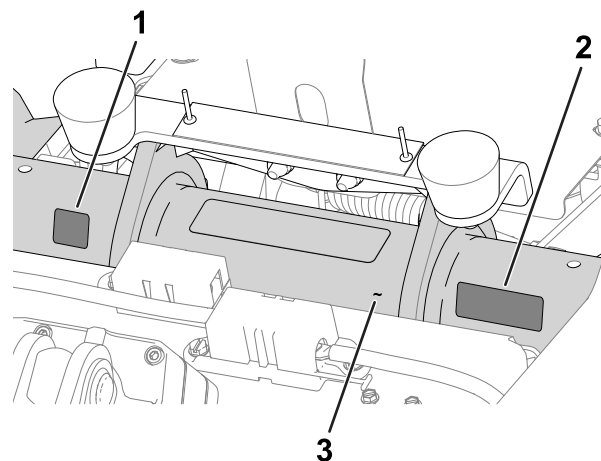

Figure 11

g280284

1. CE mark decal
2. Production year decal
3. Frame tube

- **CE warning decal**: Apply the CE warning decal (Part Number 139-8321) over the existing warning decal (Part Number 139-8320) on the steering-wheel cover; refer to [Figure 12](#).

8

Adjusting the Machine Settings

No Parts Required

Procedure

Use the InfoCenter to adjust the machine settings; refer to [Using the InfoCenter to Adjust the Machine Settings \(page 22\)](#).

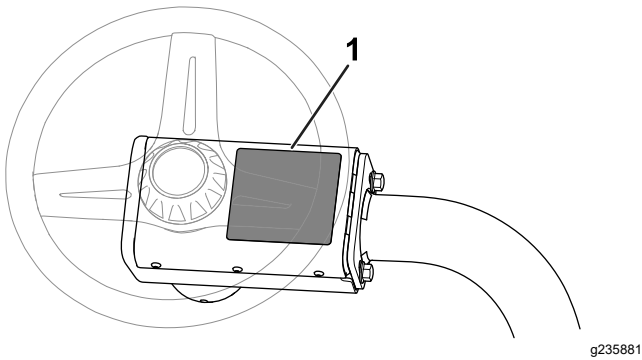

Figure 12

1. CE warning decal

12

Charging the Batteries

No Parts Required

Procedure

Charge the batteries; refer to [Charging the Lithium-Ion Batteries \(page 35\)](#).

10

Reducing the Tire Pressure

No Parts Required

Procedure

The tires are overinflated at the factory for shipping purposes. Reduce the pressure to the proper levels before turning on the machine; refer to [Checking the Tire Pressure \(page 44\)](#).

11

Mounting the Battery Charger on a Wall

Optional

No Parts Required

Procedure

You can mount the charger on a wall using the wall-mount key holes cut into the back of the unit. Use screws that have a 6 mm (1/4 inch) diameter shaft and a head diameter of 11 mm (0.45 inch).

Important: Survey your work area and determine a location that best meets the criteria for safe and effective operation of the charger.

Product Overview

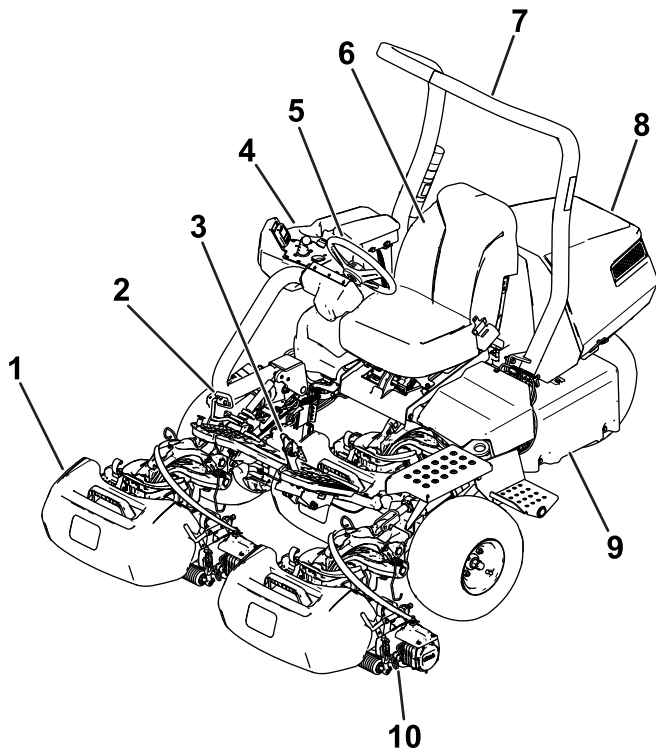

Figure 13

g289915

- | | |
|-------------------|--------------------|
| 1. Grass basket | 6. Operator's seat |
| 2. Traction pedal | 7. Roll bar |
| 3. Brake pedal | 8. Hood |
| 4. Console | 9. Battery tray |
| 5. Steering wheel | 10. Cutting unit |

Controls

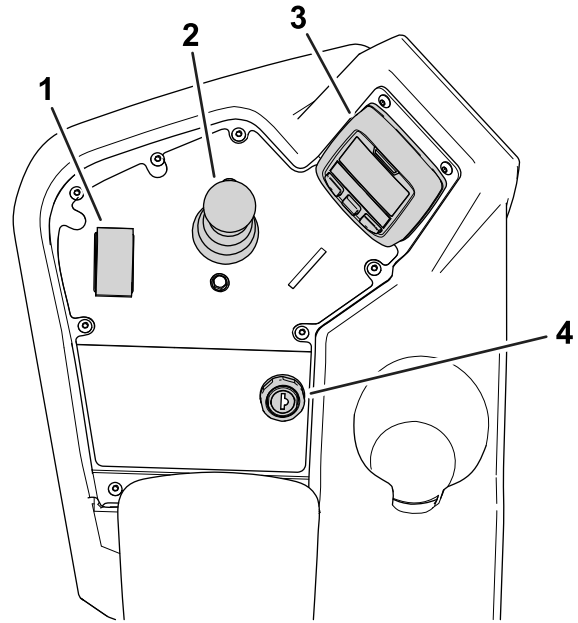

Figure 14

g267033

- | | |
|----------------------------|---------------|
| 1. Function-control switch | 3. InfoCenter |
| 2. Lift/lower joystick | 4. Key switch |

Key Switch

The key switch has 2 positions: ON and OFF ([Figure 15](#)).

Use the key switch to turn on or shut off the machine; refer to [Turning On the Machine \(page 27\)](#) and [Shutting Off the Machine \(page 30\)](#).

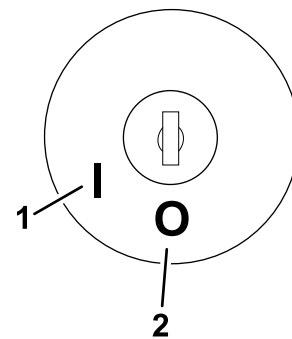

Figure 15

g292048

- | | |
|-------|--------|
| 1. ON | 2. OFF |
|-------|--------|

Function-Control Switch

The function-control switch ([Figure 14](#)) provides 2 traction selections plus a NEUTRAL position.

- NEUTRAL position—neutral and backlapping
- MOW position—used for mowing operation
- TRANSPORT position—used for transport operation

You can shift from MOW to TRANSPORT or TRANSPORT to MOW (not to NEUTRAL) while the machine is in motion; no damage will result

You can move the switch from TRANSPORT or MOW to NEUTRAL and the machine will come to a stop. If you try to switch from NEUTRAL to MOW or TRANSPORT while the pedal is not in the NEUTRAL position, an advisory occurs.

Lift/Lower Joystick

The lift/lower joystick (Figure 14) raises or lowers the cutting units. The joystick can engage or disengage the cutting-unit reels, depending on the function-control-switch position:

- **Function-control switch in the NEUTRAL position:** The cutting units will raise or lower as long as you move the joystick forward or backward, but the reels will not engage unless the machine is in Backlap Mode.
- **Function-control switch in the Mow position:** Move the joystick forward during your cutting operation to lower the cutting units and start the reels. Pull back on the joystick to stop the reels and raise the cutting units.

To stop the reels without raising the cutting units, pull back on the joystick momentarily and release it. Moving the joystick forward again will start the reels or pulling back again will lift the cutting units. You must engage this feature in the InfoCenter; refer to [Adjusting the Tap-Off Delay \(page 23\)](#).
- **Function-control switch in the TRANSPORT position:** The cutting units can be raised, but the reels will not engage. An advisory appears in the InfoCenter if you attempt to lower the cutting units.

Traction Pedal

The traction pedal (Figure 16) has 3 functions: to make the machine move forward, to move it backward, and to stop the machine. Press the top of the pedal to move forward; press the bottom to move backward or to assist in stopping when moving forward.

To stop the machine, allow the pedal to move to the NEUTRAL position. Do not rest the heel of your foot on the traction pedal in the REVERSE position while the machine is moving forward (Figure 17).

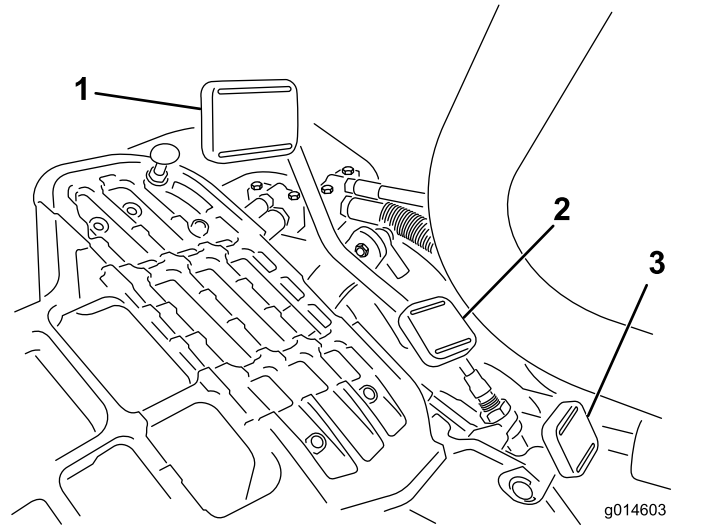

Figure 16

1. Traction pedal—forward
2. Traction pedal—reverse
3. Steering-arm-locking pedal



Figure 17

You can configure the maximum ground speed as follows:

- 3.2 to 8 km/h (3 to 5 mph) forward mowing speed
- 8 to 16 km/h (5 to 10 mph) transport speed
- 3.2 to 4.8 km/h (2 to 3 mph) reverse speed

Steering-Arm-Locking Pedal

Press the pedal (Figure 16) and raise or lower the steering arm for operator comfort, then, release the pedal to lock the arm in place.

Brake Pedal

Press the brake pedal (Figure 18) to stop the machine.

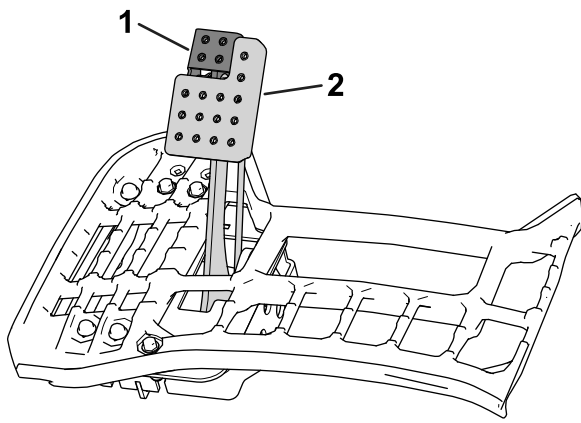

Figure 18

1. Parking brake
2. Brake pedal

g236365

Parking Brake

Use the parking brake (Figure 18) to prevent the machine from moving. To engage the parking brake, push down on the brake pedal and press the top forward to latch. To release the parking brake, press the brake pedal until the parking-brake latch retracts.

InfoCenter

Using the InfoCenter LCD Display

The InfoCenter LCD display shows information about your machine, such as the operating status, various diagnostics, and other information about the machine (Figure 22). There is a splash screen, main information screen, cutting unit (CU) motor information screen, and traction information screen.

- **Splash screen:** shows current machine information for a few seconds after you move the key to the ON position.
- **Main information screen (Figure 19):** shows current machine information while the key is in the ON position. This screen shows the battery-system charge level and the amperage.

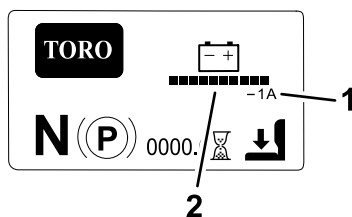

Figure 19

1. Battery-system amperage
2. Battery-system charge level

g292768

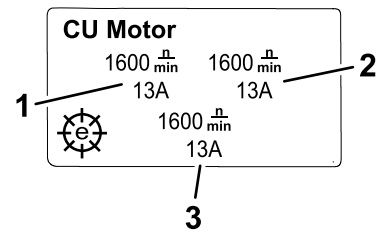

Figure 20

1. Front left cutting motor
2. Front right cutting-unit motor
3. Center cutting-unit motor

g292767

- **Traction information screen (Figure 21):** shows the current steering angle and the amperage allotted to each traction motor.

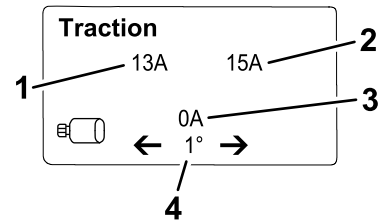

Figure 21

1. Amperage—Front, left traction motor
2. Amperage—Front, right traction motor
3. Amperage—Center traction motor
4. Steering angle

g292769

- **Main menu:** refer to [Understanding the InfoCenter Menu Items \(page 18\)](#).

Note: Protected under Protected Menus—accessible only by entering PIN; refer to [Accessing Protected Menus \(page 19\)](#).

You can switch between the main, CU motor, and traction information screens by pressing the right button and then selecting the appropriate directional arrow.

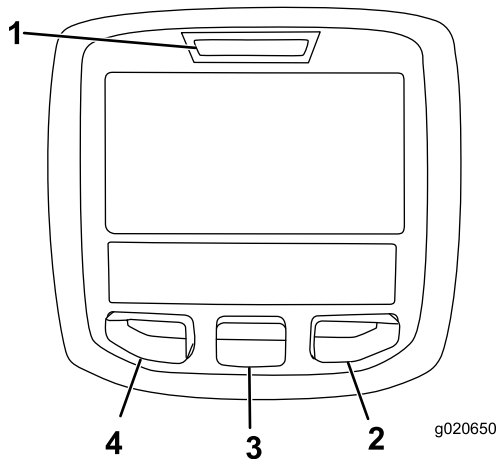

Figure 22

- 1. Indicator light
- 2. Right button
- 3. Middle button
- 4. Left button

- **Left Button, Menu Access/Back Button**—Press this button to access the InfoCenter menus. You can use it to back out of any menu you are currently using.
- **Middle Button**—Use this button to scroll down menus.
- **Right Button**—Use this button to open a menu where a right arrow indicates additional content, or to select an option.

Note: The purpose of each button may change depending on what is required at the time. Each button will be labeled with an icon displaying its current function.

InfoCenter Icon Description

SERVICE DUE	Indicates when scheduled service should be performed
	Hour meter
	Info icon
	Function-control switch is in the TRANSPORT position.
	Function-control switch is in the MOW position.
	Indicates when the cutting units are being raised.
	Indicates when the cutting units are being lowered.
	Operator must sit in seat

InfoCenter Icon Description (cont'd.)

	Parking-brake indicator—indicates when the parking brake is engaged
N	Function-control switch is in the NEUTRAL position.
	PTO is engaged
	Stop or shutdown
	Key switch
PIN	PIN code
CAN	CAN bus
	InfoCenter
	Switch
	Operator must release switch
	Operator should change to indicated state
	Traction motor
	Return to previous screen
<input type="checkbox"/>	Item not selected/active
<input checked="" type="checkbox"/>	Item selected/active
	Reel
	Electric-parking-brake indicator—indicates when the electric parking brake is engaged
Symbols are often combined to form sentences. Some examples are shown below:	
	Operator should put the machine in neutral
	Sit down or engage the parking brake

Understanding the InfoCenter Menu Items

To access the main menu, press any button while at the main, CU motor, or traction information screen, then press the button that corresponds with the  symbol. This brings you to the MAIN MENU.

Refer to the following tables for a description of the options available from the menus:

Main Menu

Menu Item	Description
FAULTS	The FAULTS menu contains a list of the recent machine faults. Refer to the <i>Service Manual</i> or your authorized Toro distributor for more information on the FAULTS menu.
SERVICE	The SERVICE menu contains information on the machine such as hours of use, counts, and calibration. You can also enable the cutting-unit backlap procedure. Refer to the Service (page 18) table.
DIAGNOSTICS	The DIAGNOSTICS menu lists various states and data that the machine currently has. You can use this information to troubleshoot certain issues, as it quickly tells you which machine controls are on/off and lists control levels (e.g., sensor values).
SETTINGS	The SETTINGS menu allows you to customize and modify configuration variables on the InfoCenter display. Refer to the Settings (page 18) table.
ABOUT	The ABOUT menu lists the model number, serial number, and software version of your machine. Refer to the About (page 19) table.









Faults

Menu Item	Description
CURRENT	Lists the total number of key-on hours (i.e., hours that the key has been in the ON position).
LAST	Indicates the last key-on hour that the fault occurred on.
FIRST	Indicates the first key-on hour that the fault occurred on.
OCCURRENCES	Indicates the number of fault occurrences.

Service

Menu Item	Description
HOURS	Lists the total number of hours that the key, reels, and backlap have been on.
COUNTS	Lists the number of mows, tap-offs, and backlaps.
BACKLAP	Engages/disengages the cutting-unit backlap procedure (when you engage this procedure, you can disengage the mode with this setting or by moving the key to the OFF position).
CALIBRATION 	Allows you to calibrate the steering system, traction system, and lift actuators. Refer to the <i>Service Manual</i> for more information on calibration.

Settings

Menu Item	Description
UNITS	Controls the units used on the InfoCenter. The menu choices are English or metric.
LANGUAGE	Controls the language used on the InfoCenter.
BACKLIGHT	Controls the brightness of the LCD display.
CONTRAST	Controls the contrast of the LCD display.
PROTECTED MENU	Allows you to access protected menus by inputting a passcode.
PROTECT SETTINGS 	Controls the protected menus.
RESET DEFAULTS 	Resets the InfoCenter to default settings.
TAPOFF TIME 	Controls the tap-off delay.
REEL SPEED 	Controls the reel speed.
LOWER SPEED 	Sets the speed that the cutting units lower to the ground for mowing.
BACKLAP RPM 	Controls the backlap rpm speed.
CLIP CONTROL 	Turns the automatic clip-control feature ON/OFF.
BLADE COUNT 	Set the number of blades in each reel. This setting is only necessary if CLIP CONTROL is set to ON.
HEIGHT OF CUT (HOC) 	Sets the desired height of cut. This setting is only necessary if CLIP CONTROL is set to ON.

Settings (cont'd.)

MAX MOW	Sets the maximum machine speed while mowing.
MAX TRANSPORT	Sets the maximum machine speed while transporting.
MAX REVERSE	Sets the maximum machine speed while moving the machine in reverse.
SLOW & TURN	Enables or disables the slow and turn function.
3WD KIT	Enables or disables the 3-Wheel Drive Kit.
BATT. RESERVE	Sets the distance that is needed to transport the machine back to the shop when the battery level becomes low.

About

Menu Item	Description
MODEL	Lists the model number of the machine.
SN	Lists the serial number of the machine.
S/W Rev	Lists the software revision of the master controller.
INFOCENTER	Lists the software revision of the InfoCenter.
CU1	Lists the software revision of the center cutting unit motor .
CU2	Lists the software revision of the front, left cutting unit motor.
CU3	List the software revision of the front, right cutting unit motor.
LL1	Lists the software part number and the revision version for the center cutting unit.
LL2	Lists the software part number and the revision version for the front left cutting unit.
LL3	Lists the software part number and the revision version for the front right cutting unit.
TRACTION1	Lists the software part number and the revision version for the front right traction motor.
TRACTION2	Lists the software part number and the revision version for the front left traction motor.
STEERING	Lists the software part number and the revision version for the rear steering motor.

About (cont'd.)

PRECHARGE	Lists the software part number and the revision version for the precharge controller.
BATTERY	Lists the software part number and the revision version for the battery.
CAN BUS	Lists the machine communication bus status.
TRACTION3	Lists the software part number and the revision version for the 3-Wheel Drive Kit (if equipped).

Note: Protected under Protected Menus—accessible only by entering PIN; refer to [Accessing Protected Menus \(page 19\)](#).

Accessing Protected Menus

Note: The factory default PIN code for you machine is either 0000 or 1234.

If you changed the PIN code and forgot the code, contact your authorized Toro distributor for assistance.

1. From the MAIN MENU, use the center button to scroll down to the SETTINGS MENU and press the right button.
2. In the SETTINGS MENU, use the center button to scroll down to the PROTECTED MENU and press the right button.
3. To enter the PIN code, press the center button until the correct first digit appears, then press the right button to move on to the next digit. Repeat this step until the last digit is entered and press the right button once more.
4. Press the middle button to enter the PIN code.

Wait until the red indicator light of the InfoCenter illuminates.

Note: If the InfoCenter accepts the PIN code and the protected menu is unlocked, the word “PIN” displays in the upper right corner of the screen.

You have the ability to view and change the settings in the Protected Menu. Once you access the Protected Menu, scroll down to the Protect Settings option. Use the right button to change the setting.

- Setting the Protect Settings to OFF allows you to view and change the settings in the Protected Menu and view the CU motor and traction information screens without entering the PIN code.
- Setting the Protect Settings to ON hides the protected options and requires you to enter the PIN code to change the setting in the Protected Menu.

After you set the PIN code, rotate the key switch to the OFF position and back to the ON position to enable and save this feature.

Note: Rotate the key switch to the OFF position and then to the ON position to lock the protected menu.

Setting the Machine Configuration Passcode

You can set a passcode on the InfoCenter so that an operator cannot access specific InfoCenter screens without it. Refer to [Understanding the InfoCenter Menu Items \(page 18\)](#) for the InfoCenter screens that are passcode-protected.

1. From the SETTINGS menu, select PROTECT SETTINGS.
2. Set PROTECT SETTINGS to ON.
3. When prompted, enter a 4-digit passcode.
4. Turn the ignition key to the OFF position to save the code.

Note: If you forget the user defined passcode, you can obtain a temporary passcode from your authorized Toro distributor.

Understanding the Fault-Log Indicator

If a fault occurs, a fault code appears on the InfoCenter screen and a red flashing light appears above the screen.

The fault is stored in a log entry located in the FAULTS menu, which you or your distributor can use to identify the issue that prompted the fault.

For a list of faults, refer to the *Service Manual* or your authorized Toro distributor.

Main-Power Connectors

Before you charge the machine, work on the machine, or install, remove, or work on the cutting units, disconnect the machine from the power supply by separating the main-power connectors ([Figure 23](#)), located at the base of the roll bar on the left side of the traction unit. Plug the connectors together before operating the machine.

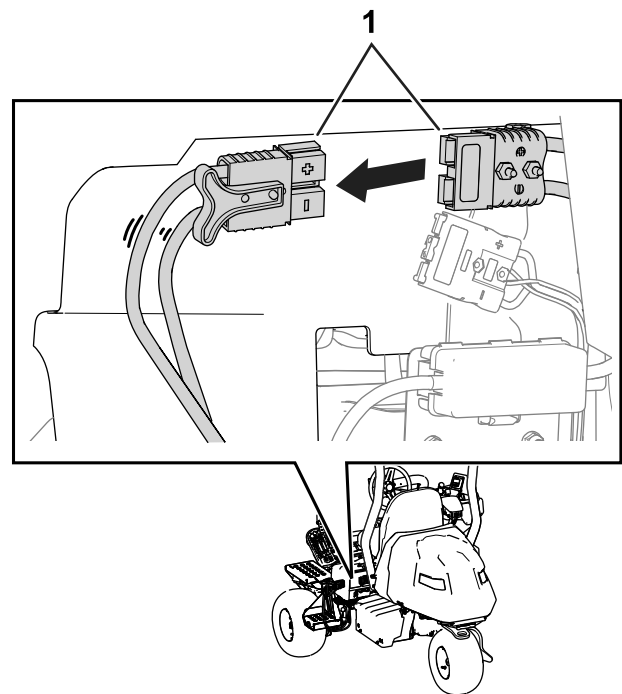

Figure 23

g293203

1. Main-power connectors

⚠ CAUTION

If you do not disconnect the power to the machine, someone could accidentally turn on the machine, causing serious bodily injury.

Always separate the connectors before working on the machine.

Specifications

Refer to [Figure 24](#) and the [Traction-Unit Specifications Table \(page 21\)](#) for traction-unit dimensions and weight.

Note: Specifications and design are subject to change without notice.

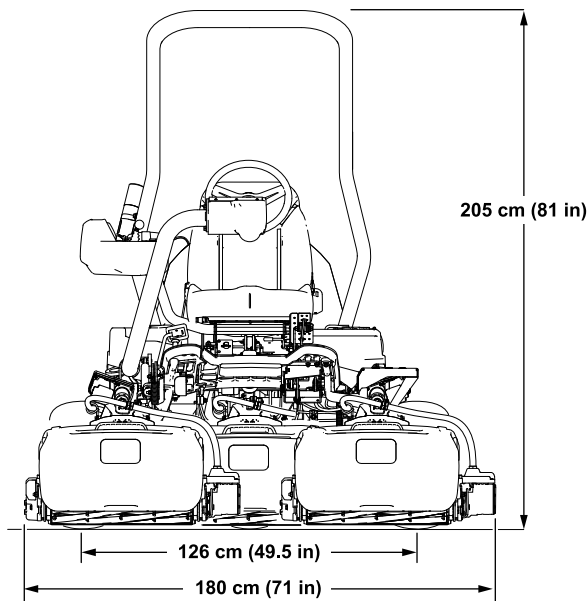

Electrical Specifications Table

Voltage	48V
Current	DC (===)
Amp Hours	213.6 AH
IP Rating	IP 65

Attachments/Accessories

A selection of Toro approved attachments and accessories is available for use with the machine to enhance and expand its capabilities. Contact your Authorized Service Dealer or authorized Toro distributor or go to www.Toro.com or a list of all approved attachments and accessories.

To ensure optimum performance and continued safety certification of the machine, use only genuine Toro replacement parts and accessories. Replacement parts and accessories made by other manufacturers could be dangerous, and such use could void the product warranty.

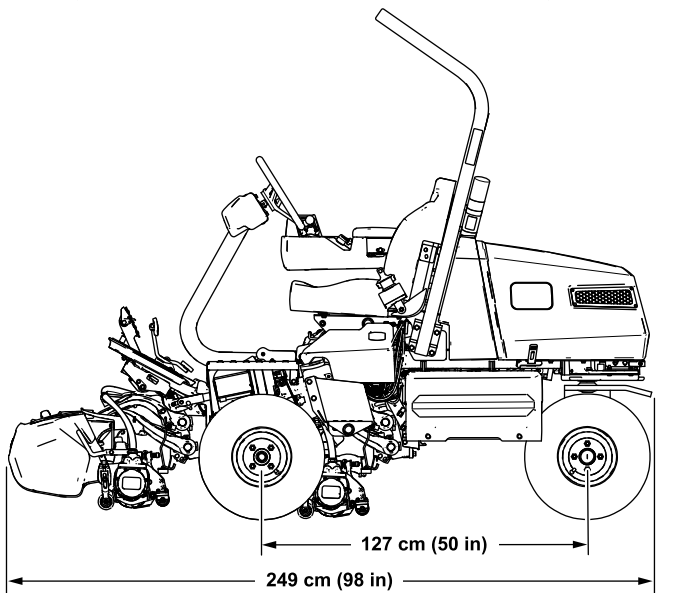

g289936

Figure 24

Traction-Unit Specifications Table

Width of cut	151 cm (59.5 inches)
Wheel track	126 cm (49.5 inches)
Wheel base	127 cm (50 inches)
Overall length (w/baskets)	249 cm (98 inches)
Overall width	180 cm (71 inches)
Overall height	205 cm (81 inches)
Weight*	738 kg (1,628 lb)

*Traction unit equipped with 11-blade cutting units, no operator, and with the Standard Seat equipped.

Operation

Before Operation

Before Operation Safety

General Safety

- Never allow children or untrained people to operate or service the machine. Local regulations may restrict the age of the operator. The owner is responsible for training all operators and mechanics.
- Become familiar with the safe operation of the equipment, operator controls, and safety signs.
- Engage the parking brake, shut off the machine, remove the key, and wait for all movement to stop before you leave the operator's position. Allow the machine to cool before adjusting, servicing, cleaning, or storing it.
- Know how to stop the machine and shut off the machine quickly.
- Check that operator-presence controls, safety switches, and safety protective devices are attached and functioning properly. Do not operate the machine unless they are functioning properly.
- Before mowing, always inspect the machine to ensure that the cutting units are in good working condition.
- Inspect the area where you will use the machine and remove all objects that the machine could throw.

Identifying the Cutting Units

The InfoCenter uses the numbers 1, 2, and 3 to identify each cutting unit (e.g., CU1, CU2, and CU3 in the ABOUT menu).

- **1** refers to the center cutting unit ([Figure 25](#))
- **2** refers to the front left cutting unit ([Figure 25](#))
- **3** refers to the front right cutting unit ([Figure 25](#))

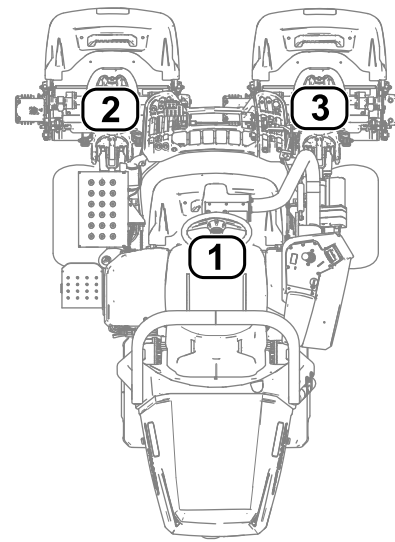

Figure 25

g289940

1. Center cutting unit
2. Front left cutting unit
3. Front right cutting unit

Using the InfoCenter to Adjust the Machine Settings

You can use the InfoCenter to adjust the following machine settings:

- **Tap-off delay**; refer to [Adjusting the Tap-Off Delay \(page 23\)](#).
- **Reel speed while mowing**; refer to [Adjusting the Mowing Reel Speed \(page 23\)](#).
- **Cutting-unit lower speed**; refer to [Setting the Cutting-Unit Lower Speed \(page 23\)](#).
- **Reel speed while backlapping the cutting units**; refer to [Adjusting the Backlap Reel Speed \(page 23\)](#).
- **Clip control**; refer to [Setting the Clip-Control Feature \(page 24\)](#).
- **Height of cut (HOC)**; refer to [Adjusting the Height of Cut \(HOC\) \(page 24\)](#).
- **Number of cutting-unit blades**; refer to [Adjusting the Number of Cutting-Unit Blades \(page 24\)](#).
- **Maximum mowing speed**; refer to [Adjusting the Maximum Mowing Speed \(page 24\)](#).
- **Maximum transport speed**; refer to [Adjusting the Maximum Transport Speed \(page 24\)](#).
- **Maximum reverse speed**; refer to [Adjusting the Maximum Reverse Speed \(page 24\)](#).
- **Slow and turn**; refer to [Setting the Slow and Turn Function \(page 24\)](#).

- **Disabling an equipped 3-Wheel-Drive Kit**; refer to [Disabling an Equipped 3-Wheel-Drive Kit \(page 24\)](#).
- **Battery-reserve capacity**; refer to [Setting the Battery-Reserve Capacity \(page 25\)](#).

Note: Each setting is passcode-protected. You may need to enter a passcode to edit the settings.

Adjusting the Tap-Off Delay

Navigate to the TAPOFF TIME option to adjust the tap-off delay. The tap-off delay feature allows the cutting units to turn off without raising. The delay setting represents the maximum time for the lift/lower joystick to remain in the rearward position to activate this feature.

Refer to the following table for the delay time options and their corresponding increment numbers:

Tap-Off Delay Options

Increment Number	Delay Time (Seconds)
1	Off
2	0.050
3	0.100
4	0.150
5	0.200
6	0.250
7	0.300
8	0.350
9	0.400
10	0.450

Note: The factory default setting is 1, which disables this feature.

Adjusting the Mowing Reel Speed

Navigate to the REEL SPEED option to adjust the reel speed while mowing. This setting can be adjusted when the clip control setting is OFF; refer to [Setting the Clip-Control Feature \(page 24\)](#).

Refer to the following table for the reel speed options and their corresponding increment numbers:

Mowing Reel Speed Options

Increment Number	Reel Speed (RPM)
1	800
2	950
3	1100
4	1250
5	1400

Mowing Reel Speed Options (cont'd.)

6	1550
7	1700
8	1850
9	2000

Note: The factory default setting is 2000 rpm (increment number 9).

Setting the Cutting-Unit Lower Speed

Navigate to the LOWER SPEED option to set the speed that the cutting units lower to the ground for mowing. You can toggle between 1 (slowest speed) and 9 (quickest speed).

Test the lower speed before you mow. Adjust the speed as desired.

Note: The factory default setting is 5.

Adjusting the Backlap Reel Speed

Navigate to the BACKLAP RPM option to adjust the reel speed while performing a backlap operation.

Refer to the following table for the reel speed options and their corresponding increment numbers:

Backlap Reel Speed Options

Increment Number	Reel Speed (RPM)
1	200
2	240
3	280
4	320
5	360
6	400
7	440
8	480
9	520

Note: The factory default setting is 200 rpm (increment number 1).

Adjusting the Clip-Control Feature

Understanding the Radius-Dependent-Speed (RDS) System

To achieve a consistent, high quality-of-cut and a uniform after cut appearance, the machine is equipped

with the patent-pending Radius Dependent Speed™ (RDS) system. The RDS system is a clip-control and independent wheel-speed feature that varies the speeds of each reel motor and each traction motor to maintain a constant clip and reduce turf scrubbing in turns while cutting.

When the machine is turning while cutting (e.g., during the clean-up pass), the reel on the inside of the turn will rotate at a slower rpm than the reel on the outside of the turn. The center reel splits the difference of the inside and outside reel speeds so that all three cutting units have the same clip. The sharper the turn, the greater the difference in reel speeds. Additionally, if the machine speed changes while you are cutting, the RDS system adjusts the reel speed to maintain a constant clip. This feature reduces turf thinning on the inside reel (in comparison to other riding greens mowers), which can reduce triplex ring.

The RDS system also adjusts each wheel-motor speed during a turn, similar to the reel-motor speeds changing in a turn. The inside wheel motor will turn at a slower rpm than the outside wheel motor. This minimizes wheel scrubbing in the turn and can reduce triplex ring.

Setting the Clip-Control Feature

Navigate to the CLIP CONTROL option to set the RDS system feature.

- Clip control set to ON: The machine uses your settings from the HEIGHT OF CUT (HOC) and BLADE COUNT options and the left and right wheel speeds to determine the speed of each reel.
- Clip control set to OFF: The machine uses your setting from the REEL SPEED option. The reels rotate at a constant rate.

Note: The factory default setting is ON.

Adjusting the Height of Cut (HOC)

Navigate to the HEIGHT OF CUT (HOC) option to adjust the height of cut. The clip control feature must be set to ON to use this feature; refer to [Setting the Clip-Control Feature \(page 24\)](#).

Note: The factory default setting is 3.2 mm (0.125 inch).

Adjusting the Number of Cutting-Unit Blades

Navigate to the BLADE COUNT option to adjust the number of cutting-unit blades. Determine the number of blades in your equipped cutting units, and select the appropriate value (5, 8, 11, or 14).

Note: The factory default setting is 11.

Adjusting the Maximum Mowing Speed

Navigate to the MAX MOW option to adjust the maximum mowing speed. You can adjust the speed from 4.8 km/h (3.0 mph) to 8.0 km/h (5.0 mph) in increments of 0.3 km/h (0.2 mph).

Note: The factory default setting is 6.1 km/h (3.8 mph).

Adjusting the Maximum Transport Speed

Navigate to the MAX TRANSPORT option to adjust the maximum transport speed. You can adjust the speed from 8.0 km/h (5.0 mph) to 16.0 km/h (10.0 mph) in increments of 0.8 km/h (0.5 mph).

Note: The factory default setting is 16.0 km/h (10.0 mph).

Adjusting the Maximum Reverse Speed

Navigate to the MAX REVERSE option to adjust the maximum reverse speed. You can adjust the speed from 3.2 km/h (2.0 mph) to 8.0 km/h (5.0 mph) in increments of 0.8 km/h (0.5 mph).

Note: The factory default setting is 4.0 km/h (2.5 mph).

Note: For machine-software versions A through D, the maximum speed is 4.8 km/h (3.0 mph). Update the machine software for the capability to set the maximum speed to 8.0 km/h (5.0 mph).

Setting the Slow and Turn Function

Navigate to the SLOW & TURN option to set the slow and turn function. The slow and turn function slows the machine speed while you turn the machine for another cutting pass on a green.

Note: The factory default setting is OFF.

Disabling an Equipped 3-Wheel-Drive Kit

Navigate to the 3WD KIT option to disable an equipped 3-Wheel-Drive Kit.

If you choose to disable this option, the kit will be enabled again if you cycle the key switch (i.e., turn off, then turn on the machine) with an equipped 3-Wheel-Drive Kit.

Note: When you install the 3-Wheel-Drive Kit, the kit is automatically enabled.

Setting the Battery-Reserve Capacity

Navigate to the BATT. RESERVE option to set the amount of distance needed to transport the machine to the shop. This allows you to have enough battery power (when the battery level becomes too low) to transport the machine to the shop for recharging; refer to [Monitoring the Battery-System Charge Level \(page 30\)](#).

Note: You can adjust the distance from 0.8 km (0.5 mi) to 8 km (5 mi) in 0.8 km (0.5 mi) increments.

Understanding the InfoCenter Dialog Messages

When the machine is being calibrated, dialog messages appear in the InfoCenter. These messages are intended to instruct you through the calibration process.

Refer to the following table for a list of each dialog message:

Dialog Messages

Message Number	InfoCenter Message Text
1	Return pedal to neutral
4	Move pedal to max forward and hold
5	Max forward calibration passed
9	Max forward calibration failed. Voltage out of spec
13	Move pedal to max reverse and hold
14	Max reverse calibration passed
16	Max reverse calibration failed. Voltage out of spec
17	Calibration failed. Pedal position unknown
18	Return pedal to neutral. Continue?
100	Calibration is engaged
101	Calibration is complete
102	Cycle the key switch
110	Inhibit calibration. Component not responding
111	Inhibit calibration. Component not ready
112	Inhibit calibration. Fault active
113	Inhibit calibration. Not in seat
114	Inhibit calibration. Not in neutral
115	Inhibit calibration. In neutral

Dialog Messages (cont'd.)

116	Inhibit calibration. Parking brake is engaged
300	Return pedal to neutral
301	Center steering wheel. Continue?
302	Manually center rear wheel. Continue?
303	Steer rear wheel max left. Continue?
304	Steer rear wheel max right. Continue?
305	Rear wheel center out of range
306	Rear wheel angle out of range
400	Caution: Machine must be on jack stands. Continue?
401	Inhibit calibration. Contactor open
402	Inhibit calibration. Pedal in Neutral
403	Return pedal to neutral
404	Wait for wheels to stop
405	Move pedal to max forward and hold
406	Calibration active. Hold pedal
500	Lift/Lower extend active
501	Lift/Lower retract active
502	Move joystick to lower position
503	Move joystick to raise position
504	Is the cutting unit installed? Continue?
1100	Traction diagnostic messages enabled
1101	Steering diagnostic messages enabled

Tilting the Steering Wheel

You can tilt the steering wheel to a comfortable operating position.

1. Loosen the bolts ([Figure 26](#)) that secure the steering-wheel assembly to the steering arm.

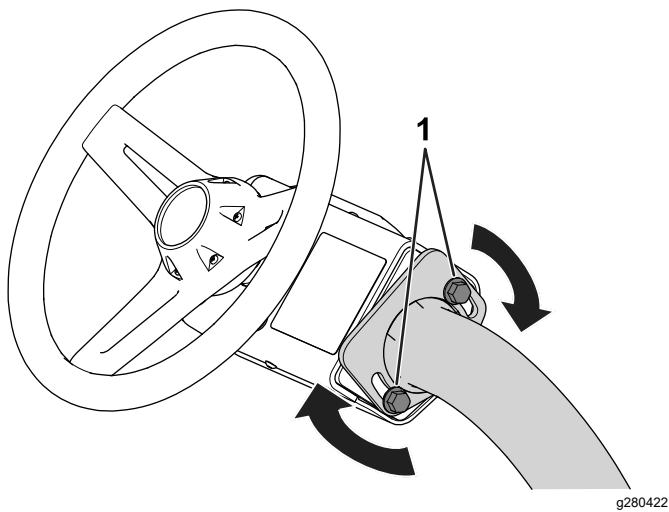

Figure 26

1. Bolt

2. Tilt the steering wheel to a comfortable position.
3. Tighten the bolts (Figure 26) to secure the steering-wheel assembly in your adjusted position.

Performing Daily Maintenance

Service Interval: Before each use or daily

Before turning on the machine each day, perform the following procedures:

- Check the reel-to-bedknife contact; refer to [Checking the Reel-to-Bedknife Contact \(page 49\)](#).
- Check the tire pressure; refer to [Checking the Tire Pressure \(page 44\)](#).
- Check the safety-interlock system; refer to [Checking the Safety-Interlock System \(page 28\)](#).
- Check the parking brake function by actuating the parking brake and ensuring that it engages; refer to [Parking Brake \(page 16\)](#).

During Operation

During Operation Safety

General Safety

- The owner/operator can prevent and is responsible for accidents that may cause personal injury or property damage.
- Wear appropriate clothing, including eye protection; long pants; substantial, slip-resistant footwear, and hearing protection. Tie back long

hair and do not wear loose clothing or loose jewelry.

- Do not operate the machine while ill, tired, or under the influence of alcohol or drugs.
- Use your full attention while operating the machine. Do not engage in any activity that causes distractions; otherwise, injury or property damage may occur.
- Before you turn on the machine, ensure that all drives are in neutral, the parking brake is engaged, and you are in the operating position.
- Do not carry passengers on the machine.
- Keep bystanders and children out of the operating area. If co-workers must be present, use caution and ensure that the grass baskets are installed on the machine.
- Operate the machine only in good visibility to avoid holes or hidden hazards.
- Avoid mowing on wet grass. Reduced traction could cause the machine to slide.
- Keep your hands and feet away from the cutting units.
- Look behind and down before backing up to be sure of a clear path.
- Use care when approaching blind corners, shrubs, trees, or other objects that may obscure your vision.
- Stop the cutting units whenever you are not mowing.
- Slow down and use caution when making turns and crossing roads and sidewalks with the machine. Always yield the right-of-way.
- Do not leave an activated machine unattended.
- Before you leave the operating position, do the following:
 - Park the machine on a level surface.
 - Lower the cutting units to the ground and ensure that they are disengaged.
 - Engage the parking brake.
 - Shut off the machine and remove the key.
 - Wait for all movement to stop.
- Operate the machine only in good visibility and appropriate weather conditions. Do not operate the machine when there is the risk of lightning.

Rollover Protection System (ROPS) Safety

- Do not remove any of the ROPS components from the machine.

- Ensure that the seat belt is attached and that you can release it quickly in an emergency.
- Always wear your seat belt.
- Check carefully for overhead obstructions and do not contact them.
- Keep the ROPS in safe operating condition by thoroughly inspecting it periodically for damage and keeping all the mounting fasteners tight.
- Replace all damaged ROPS components. Do not repair or alter them.

Slope Safety

- Slopes are a major factor related to loss of control and rollover accidents, which can result in severe injury or death. You are responsible for safe slope operation. Operating the machine on any slope requires extra caution.
- Evaluate the site conditions to determine if the slope is safe for machine operation, including surveying the site. Always use common sense and good judgment when performing this survey.
- Review the slope instructions, listed below, for operating the machine on slopes. Before you operate the machine, review the site conditions to determine whether you can operate the machine in the conditions on that day and at that site. Changes in the terrain can result in a change in slope operation for the machine.
- Avoid starting, stopping, or turning the machine on slopes. Avoid making sudden changes in speed or direction. Make turns slowly and gradually.
- Do not operate a machine under any conditions where traction, steering, or stability is in question.
- Remove or mark obstructions such as ditches, holes, ruts, bumps, rocks, or other hidden hazards. Tall grass can hide obstructions. Uneven terrain could overturn the machine.
- Be aware that operating the machine on wet grass, across slopes, or downhill may cause the machine to lose traction. Loss of traction to the drive wheels may result in sliding and a loss of braking and steering.
- Use extreme caution when operating the machine near drop-offs, ditches, embankments, water hazards, or other hazards. The machine could suddenly roll over if a wheel goes over the edge or the edge caves in. Establish a safety area between the machine and any hazard.
- Identify hazards at the base of the slope. If there are hazards, mow the slope with a pedestrian-controlled machine.
- If possible, keep the cutting units lowered to the ground while operating on slopes. Raising the

cutting units while operating on slopes can cause the machine to become unstable.

- Use extreme caution with grass-collection systems or other attachments. These can change the stability of the machine and cause a loss of control.

Breaking in the Machine

8 hours of operation is required for the break-in period.

Since the first hours of operation are critical to future dependability of the machine, monitor its functions and performance closely so that minor difficulties, which could lead to major problems, are noted and can be corrected. Inspect the machine frequently during break-in for signs of loose fasteners or any other malfunction.

Turning On the Machine

Note: Inspect the areas beneath the cutting units to ensure that they are clear of debris.

1. Sit in the operator's seat and fasten the seatbelt.
2. Insert the key into the switch and move it to the ON position.

Checking the Machine after Turning On the Machine

1. Move the function-control switch to the Mow position.
2. Disengage the parking brake.
3. Move the lift/lower joystick forward momentarily.
4. Move the lift/lower joystick rearward.

The cutting units should lower and all the reels should rotate.

The cutting reels should stop rotating and the cutting units should raise to the full transport position.

Understanding the Safety-Interlock System

Service Interval: Before each use or daily

▲ CAUTION

If the safety interlock switches are disconnected or damaged the machine could operate unexpectedly, causing personal injury.

- Do not tamper with the interlock switches.
- Check the operation of the interlock switches daily and replace any damaged switches before operating the machine.

The purpose of the safety-interlock system is to prevent operation of the machine where there is possible injury to you or damage to the machine.

The safety-interlock system prevents the machine from moving unless:

- The parking brake is disengaged.
- You are seated in the operator's seat.
- The function-control switch is in the MOW position or the TRANSPORT position.

Additionally, the safety-interlock system prevents the reels from operating unless the function-control switch is in the MOW position (except when the machine is in Backlap Mode).

Checking the Safety-Interlock System

Perform the following steps to check the interlock system:

- Rise from the seat, turn on the machine, disengage the parking brake, move the function-control switch to the MOW or TRANSPORT position, and engage the traction pedal.

The machine should not move, as you are not in the seat. This indicates that the interlock system is operating correctly. Correct the problem if it is not operating properly.

- Sit in the seat, turn on the machine, engage the parking brake, move the function-control switch to the MOW or TRANSPORT position, and engage the traction pedal.

The machine should not move, as the parking brake is engaged. This indicates that the interlock system is operating correctly. Correct the problem if it is not operating properly.

- Sit in the seat, turn on the machine, disengage the parking brake, move the function-control switch to the NEUTRAL position, and engage the traction pedal.

The machine should not move, as the function-control switch is in the NEUTRAL position. This indicates that the interlock system is operating

correctly. Correct the problem if it is not operating properly.

- Sit on the seat, move the traction pedal to the NEUTRAL position, move the function-control switch to the NEUTRAL position, engage the parking brake, turn on the machine, and move the lift/lower joystick forward to lower the cutting units.

The cutting units should lower but not start rotating. If they start rotating, the interlock system is not operating correctly; correct the problem before operating the machine.

Driving the Machine without Mowing

- Ensure that the cutting units are fully raised.
- Sit in the seat, fasten the seat belt, disengage the parking brake, and move the function-control switch to the TRANSPORT position to drive the machine without mowing.
- Always approach irregular areas at a reduced speed and cross severe undulations carefully.
- Familiarize yourself with the width of the machine. Do not attempt to pass between objects that are close together to prevent costly damage and downtime.

Mowing the Green

Before mowing greens, find a clear area and practice performing basic machine functions (e.g., turning on and stopping the machine, raising and lowering the cutting units, and turning).

Inspect the green for debris, remove anything that may damage the cutting units while mowing, remove the flag from the cup, and determine the best direction to mow. Base the direction to mow on the previous mowing direction. Always mow in an alternate pattern from the previous mowing so that the grass blades are less apt to lay down and will have a greater chance of being cut.

Cutting the Green

1. Start on 1 edge of the green so that you can use the ribbon procedure of cutting.
Note: This holds compaction to a minimum and leaves a neat, attractive pattern on the greens.
2. Move the function-control switch to the MOW position.
3. Push forward the lift/lower mow lever as the front edges of the grass baskets cross the outer edge of the green.

Note: This procedure drops the cutting units to the turf and starts the reels.

Important: The center cutting unit lifts or lowers slightly after the front cutting units do; therefore, you should practice gaining the required timing necessary to minimize the cleanup mowing operation and prevent scalping of the fringe.

The center cutting unit lift and lower is based on ground speed. A slower ground speed increases the lift or lower delay; a faster speed decreases the lift or lower delay. The machine monitors the ground speed and updates this delay so that all three cutting units drop in a line.

4. Overlap a minimal amount with the previous cut on return passes.

Note: To assist in maintaining a straight line across the green and keeping the machine an equal distance from the edge of the previous cut, imagine a sight line approximately 1.8 to 3 m (6 to 10 ft) ahead of the machine to the edge of the uncut portion of the green (Figure 28). Include the outer edge of the steering wheel as part of the sight line; i.e., keep the steering wheel edge aligned with a point that is always kept the same distance away from the front of the machine.

5. As the front edges of the baskets cross the edge of the green, pull back the lift/lower joystick rearward and hold it until all the cutting units have risen. This stops the reels and lifts the cutting units.

Important: Time this step correctly so that you do not cut into the fringe area, yet cut as much of the green as possible to minimize the amount of grass left to mow around the outer periphery.

6. To cut down on operating time and to ease the lineup for the next pass, momentarily turn the machine in the opposite direction, then turn it in the direction of the uncut portion. This movement is a tear-shaped turn (Figure 27), which quickly lines the machine up for your next pass.

Note: If the Slow and Turn function is engaged, the machine slows down during the turn without requiring you to release pressure on the traction pedal.

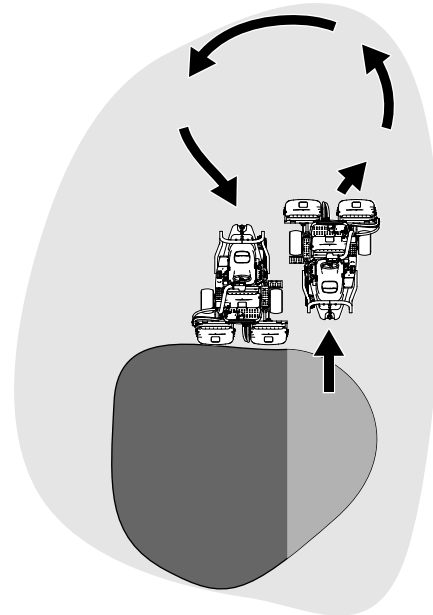

Figure 27

g229671

Note: Try to make as short of a turn as possible, except during warmer weather—a wider arc minimizes the turf bruising.

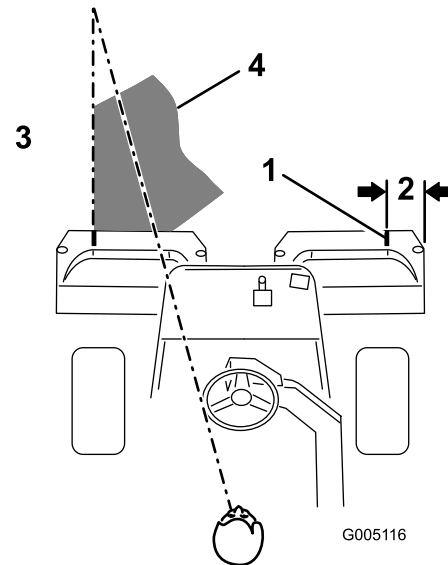

Figure 28

g005116

1. Alignment strip
2. Approximately 12.7 cm (5 inches)
3. Cut grass on the left.
4. Keep a focal spot 2 to 3 m (6 to 10 ft) ahead of the machine.

Important: Never stop the machine on a green, especially while the cutting units are engaged; damage to the turf may result. Stopping the machine on a green may leave marks or indentations from the wheels.

Cutting the Periphery and Finishing the Job

1. Finish cutting the green by mowing the outer periphery. Change the direction of cutting from the previous mowing.

Refer to [Understanding the Radius-Dependent-Speed \(RDS\) System \(page 23\)](#) to improve the after-cut appearance and reduce triplex ring.

Note: Always keep weather and turf conditions in mind and be sure to change the direction of mowing from the previous cutting.

2. When you finish mowing the outer periphery, tap the lift/lower joystick rearward to stop the reels (if the tap-off delay feature is engaged), then drive off the green. When all the cutting units are off the green, move the lift/lower joystick rearward to raise the cutting units.

Note: This step minimizes grass clumps left on the green.

3. Replace the flag.
4. Empty the grass baskets of all clippings before you transport the machine to the next green.

Note: Heavy wet clippings cause strain on the baskets, suspensions, and actuators. This adds unnecessary weight to the machine, which decreases energy efficiency.

Monitoring the Battery-System Charge Level

Refer to the main information screen in the InfoCenter to determine the battery-system charge level; refer to [Using the InfoCenter LCD Display \(page 16\)](#).

Understanding the Low Battery-Level Advisories

- When the battery level reaches a low percentage, an low-battery advisory appears on the InfoCenter. When you are operating at this battery percentage, finish cutting the current green, then transport the machine to a designated battery-charging area and charge the batteries; refer to [Charging the Lithium-Ion Batteries \(page 35\)](#).
- If the battery level becomes too low (i.e., below 10%) while you are operating the machine, an advisory appears on the InfoCenter. While you are operating at this battery percentage, you can only transport the machine at a slower speed; the cutting units cannot be engaged. Transport your

machine to a designated battery-charging area and charge the batteries; refer to [Charging the Lithium-Ion Batteries \(page 35\)](#).

Shutting Off the Machine

1. Transport the machine to a level surface.
2. Move the function-control switch to the NEUTRAL position.
3. Engage the parking brake.
4. Rotate the key to the OFF position to shut off the machine.
5. Remove the key.

After Operation

After Operation Safety

General Safety

- Engage the parking brake, shut off the machine, remove the key, and wait for all movement to stop before you leave the operator's position. Allow the machine to cool before adjusting, servicing, cleaning, or storing it.
- Clean grass and debris from the machine, especially the cutting units and drives, to help prevent fires.
- Disconnect the main-power connectors while storing or hauling the machine.
- Disengage the drive to the attachment whenever you are hauling or not using the machine.
- Allow the machine to cool before storing the machine in any enclosure.
- Maintain and clean the seat belt(s) as necessary.
- Do not store the machine where there is an open flame, spark, or pilot light, such as on a water heater or on other appliances.

Towing Safety

- Tow only with a machine that has a hitch designed for towing. Do not attach towed equipment except at the hitch point.
- Follow the manufacturer's recommendation for weight limits for towed equipment and towing on slopes. On slopes, the weight of the towed equipment may cause loss of traction and loss of control.
- Never allow children or others in or on towed equipment.
- Travel slowly and allow extra distance to stop when towing.

Battery and Charger Safety

General

- Improperly using or maintaining the battery charger could result in injury. To reduce this potential, comply with the all safety instructions.
- Use only the supplied charger for battery charging.
- Confirm the voltage that is available in your country before using the charger.
- For connection to a supply not in the US, use an attachment plug adapter of the proper configuration for the power outlet, if needed.
- Do not charge the machine in rain or wet conditions.
- Do not get the charger wet; keep it protected from rain and snow.
- A risk of fire, electric shock, or injury may result from using an accessory not recommended or sold by Toro.
- To reduce risk of a battery explosion, follow these instructions and the instructions for any equipment that you intend to use near the charger.
- Batteries could emit explosive gasses if they are significantly overcharged.
- Do not open batteries.
- In the event that a battery leaks, avoid contact with the liquid. If you accidentally come into contact with the liquid, flush with water and seek medical help. Liquid ejected from the battery may cause irritation or burns.
- Refer to an authorized Toro distributor to service or replace a battery.

Training

- Never allow children or untrained people to operate or service the charger. Local regulations may restrict the age of the operator. The owner is responsible for training all operators and mechanics.
- Read, understand, and follow all instructions on the charger and in the manual before operating the charger. Be familiar with the proper use of the charger.

Preparation

- Keep bystanders and children away while charging.
- Wear appropriate clothing while charging, including eye protection; long pants; and substantial, slip-resistant footwear.
- Shut off the machine and wait 5 seconds until the machine has completely powered down before charging. Failure to do this may cause arcing.

- Ensure that the area is well ventilated while charging.
- Read and follow all precautions for charging.
- The charger is for use only on nominal 120 and 240 VAC circuits, and is equipped with a grounding plug for 120 VAC operation. For use with 240 V circuits, contact your authorized Toro distributor for the correct power cord.

Operation

- Do not abuse the cord. Do not carry the charger by the cord or yank on the power supply cord to disconnect the charger from the receptacle. Keep the cord from heat, oil, and sharp edges.
- Connect the charger directly to a grounding (3-prong) receptacle. Do not use the charger on an ungrounded outlet, even with an adaptor.
- Do not alter the provided power cord or plug.
- Avoid dropping a metal tool near or onto a battery; it might cause a spark or short-circuit an electrical part that could lead to an explosion.
- Remove metal items such as rings, bracelets, necklaces, and watches when working with a lithium-ion battery. A lithium-ion battery can produce enough current to cause a severe burn.
- Never operate the charger without good visibility or light.
- Use an appropriate extension cord.
- If the power supply cord is damaged while it is plugged in, disconnect the cord from the wall receptacle and contact an authorized Toro distributor for a replacement.
- Unplug the charger from the electrical outlet when not in use, before moving it to another location, or prior to servicing it.

Maintenance and Storage

- Store the charger indoors in a dry, secure place that is out of the reach of unauthorized users.
- Do not disassemble the charger. Take the charger to an authorized Toro distributor when service or repair is required.
- Unplug the power cord from the outlet before starting any maintenance or cleaning to reduce risk of electric shock.
- Maintain or replace safety and instruction labels as needed.
- Do not operate the charger with a damaged cord or plug. Replace a damaged cord or plug immediately.
- If the charger has received an impact, been dropped, or otherwise damaged, do not use it; take it to an authorized Toro distributor.

Inspecting and Cleaning after Mowing

After mowing, thoroughly wash the machine with a garden hose without a nozzle so that excessive water pressure does not contaminate and damage the seals, bearings, and electronics. **Do not wash the electrical connections with water.**

Important: Do not use brackish or reclaimed water to clean the machine.

Important: Do not use power-washing equipment to wash the machine. Power-washing equipment may damage the electrical system, loosen important decals, or wash away necessary grease at friction points. It may force water under seals, contaminating oil or grease contained housings. Avoid excessive use of water near the control panel and batteries.

Inspect the cutting units for sharpness after you clean the machine.

Hauling the Machine

- Use care when loading or unloading the machine into a trailer or a truck.
- Use a full-width ramp for loading the machine into a trailer or a truck.
- Tie the machine down securely using straps, chains, cable, or ropes. Both front and rear straps should be directed down and outward from the machine (Figure 29).

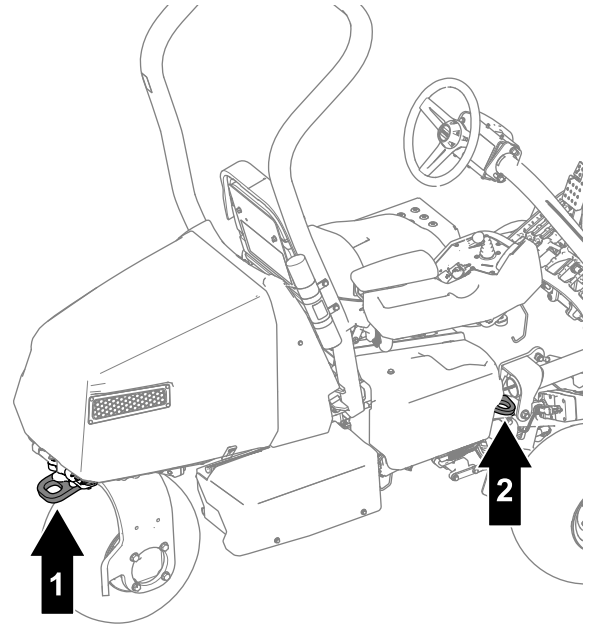

g292693

Figure 29

1. Rear tie-down loop
2. Tie-down loop (each side of the machine)

Towing the Machine

Note: Refer to [Figure 30](#) for this procedure.

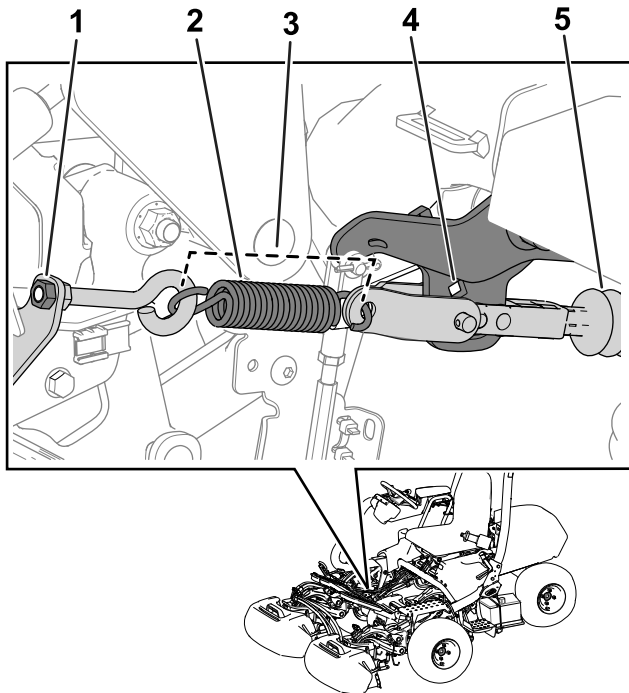

Figure 30

g267401

- | | |
|---------------------------------------|---------------------|
| 1. Nut | 4. Arm-bracket hole |
| 2. Spring | 5. Actuator shaft |
| 3. Spring length—11.4 cm (4.5 inches) | |

To tow the machine, you must perform the following procedure to release the brake actuator:

1. Engage the parking brake.
2. Remove the key and disconnect the main-power connectors.

Important: If the main-power connectors are connected while towing, electrical damage may result.

3. If the 3-Wheel Drive Kit is installed, disconnect the kit-wire-harness connectors from the main wire harness.

Important: If the kit and machine wire harnesses are connected while towing, electrical damage may result.

4. Chock both sides of the front tires.
5. Release tension on the spring by loosening the nut that secures the eyebolt to the spring bracket ([Figure 30](#)).
6. Remove the spring.
7. Insert a ratchet (3/8 inch) through the hole of the arm bracket and push in the actuator shaft.

▲ DANGER

When the actuator is released from the brake, the machine is able to free wheel. A free-wheeling machine can cause serious injury to bystanders.

If the machine is not being towed, engage the parking brake.

8. Have an assistant sit in the seat, fasten the seatbelt, and use the brake while you tow the machine.

Note: This ensures that the machine is under control when you tow the machine.

9. Remove the chocks from the tires.
10. When the machine is ready to be towed, disengage the parking brake.
11. Use the rear castor fork to tow the machine ([Figure 31](#)).

Important: Do not exceed 5 km/h (3 mph) while towing the machine. Damage to the electrical components may result.

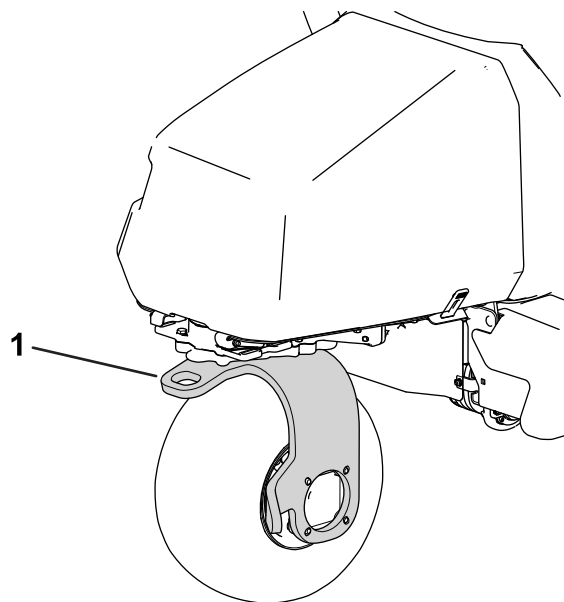

Figure 31

g270135

1. Rear castor fork

After you have towed the machine to your intended destination, perform the following steps:

1. Engage the parking brake.
2. Remove the tow strap from the castor fork.
3. Install the spring as shown in [Figure 30](#).
4. Tighten the eyebolt nut so that the spring length is 11.4 cm (4.5 inches) when installed ([Figure 30](#)).

Maintaining the Lithium-Ion Batteries

▲ WARNING

The batteries contain high voltage, which could burn or electrocute you.

- Do not attempt to open the batteries.
- Use extreme care when handling a battery with a cracked case.
- Use only the charger designed for the batteries (Model 04012).

The lithium-ion batteries hold a sufficient charge to perform intended work during its life span. During the first 4 years of operation, the total area that you can cut per a single full charge is 13,006 m² (140,000 ft²). This performance is based on the following conditions:

- Your reel blades and bedknives are sharp.
- The bedknife and reel contact is adjusted per the *Operator's Manual*.
- The groomer is set at half of the height of cut or higher.
- The rear roller brushes are set to the lightest contact.
- 8 miles of transport distance is needed.
- The golf course that you perform work on is lightly undulated.

As time goes by, the total amount of work that the batteries are able to complete on a single charge gradually diminishes.

Note: Your results may vary depending on the distance that you need to transport the machine, the undulations that you travel across, the contact setting and sharpness of the bedknife and reel, and other factors as discussed in this section.

To achieve maximum life and use from your batteries, follow these guidelines:

- Do not open the battery. There are no user serviceable parts inside. If you open the pack, you will void your warranty. The batteries are protected by tamper-alerting devices.
- Store/park the machine in a clean, dry garage or storage area, **away from direct sunlight, heat sources, rain, and wet conditions**. Do not store it in a location where the temperature drops below -30°C (-22°F) or rises above 60°C (140°F). **Temperatures outside of this range will damage your batteries**. High temperatures during storage, especially at a high state of charge, reduces the life of the batteries.

- When storing the machine for more than 10 days, ensure that the machine is in a cool and dry location, out of sunlight, rain, and wet conditions, and at least 50% charged.
- If you are mowing in hot conditions or in sunlight, the battery may overheat. If this happens, a high-temperature alert will appear on the InfoCenter. In this condition, the cutting units are disengaged and the machine slows down.

Immediately drive the machine to a cool location out of the sun, turn off the machine, and allow the batteries to cool fully before resuming operation.

- Adjust the reel-to-bedknife contact to be as light as possible. This reduces the power that is needed to run the cutting units, and increases the amount of work the machine performs on each charge. Refer to [Checking the Reel-to-Bedknife Contact \(page 49\)](#).
- Ensure that the sharpness of the bedknives and reels are maintained. A dull blade increases power consumption and reduces the amount of work that the machine performs on each charge.
- If you are using groomers, the groomer height should not exceed more than half of the height of cut. If the height of cut is over 1/2 inch, the groomer height should not exceed 1/4 inch.
- Adjust the rear-roller-brush contact to be as light as possible. This reduces the power that is needed to run the cutting units, and increases the amount of work the machine performs on each charge.
- Use lights (if your machine is equipped with the Light Kit) only when it is necessary.

Transporting the Lithium-Ion Batteries

The US Department of Transportation and international transportation authorities require that lithium-ion batteries be transported using special packaging and only be transported by carriers certified to haul them. In the US, you are allowed to transport a battery when it is installed on the machine as battery powered equipment, with some regulatory requirements. Contact the US Department of Transportation or the appropriate government body in your country for detailed regulations on transportation of your batteries or the machine with the batteries equipped.

For detailed information on shipping a battery, contact your authorized Toro distributor.

Understanding the Lithium-Ion Battery Charger

Refer to [Figure 32](#) for an overview of the battery-charger displays and cords.

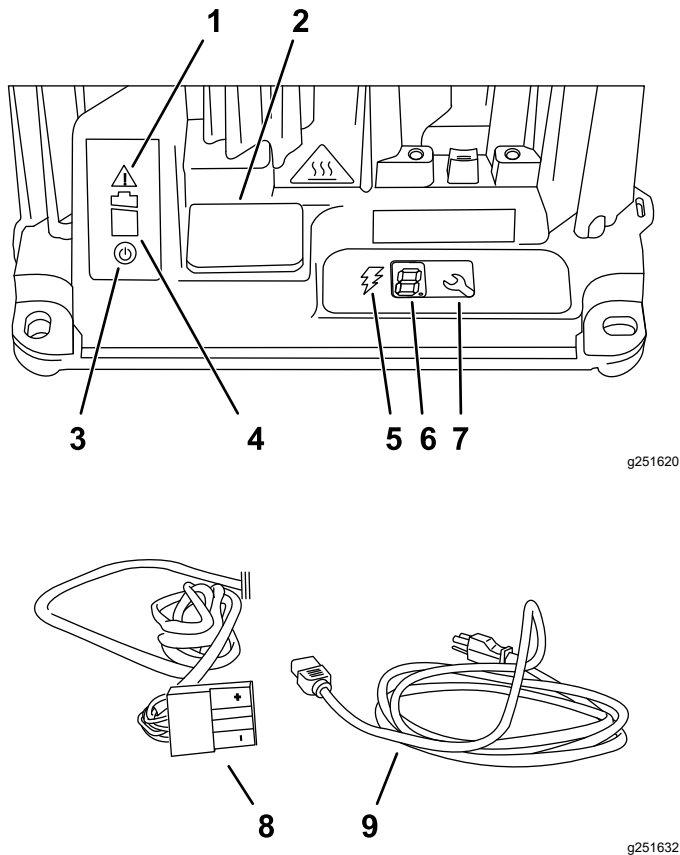

Figure 32

- | | |
|-------------------------------------|------------------------------|
| 1. Error indicator light | 6. LCD display |
| 2. USB port cover | 7. Select button |
| 3. AC Power indicator light | 8. Output connector and cord |
| 4. Battery-charging indicator light | 9. Power-supply cord |
| 5. Charging-output indicator light | |

Connecting to a Power Source

To reduce the risk of electric shock, this charger has a 3-prong grounded plug (type B). If the plug does not fit into the wall receptacle, other grounded plug types are available; contact an authorized Toro distributor.

Do not change the charger or the power-supply-cord plug in any way.

⚠ DANGER

Contact with water while charging the machine could cause electric shock, causing injury or death.

- Do not handle the plug or the charger with wet hands or while standing in water.
- Do not charge the batteries in the rain or in wet conditions.

Important: Check the power supply cord periodically for holes or cracks in the insulation. Do not use a damaged cord. Do not run the cord through standing water or wet grass.

1. Insert the charger plug on the power-supply cord into the matching input power socket on the charger.

⚠ WARNING

A damaged charger cord can cause an electrical shock or a fire.

Thoroughly inspect the power supply cord before using the charger. If the cord is damaged, do not operate the charger until you obtain a replacement.

2. Insert the wall plug end of the power supply cord into a grounded electrical outlet.

Charging the Lithium-Ion Batteries

⚠ CAUTION

Attempting to charge the batteries with a charger not provided by Toro can result in excessive heat and other related product malfunctions, which can lead to property damage and/or injury.

Use the charger (Model 04012) to charge the batteries.

Important: Charge the batteries only in temperatures that are within the recommended range; refer to the following table for the recommended range:

Note: The charger will not function in temperatures exceeding the minimum or maximum temperatures shown in the following table.

Recommended Temperature Range for Charging

Charging range	0° to 45°C (32° to 113°F)
Low-temperature charging range (Reduced Current)	-5° to 0°C (23° to 32°F)
High-temperature charging range (Reduced Current)	45° to 60°C (113° to 140°F)

1. Park the machine in the designated location for charging.
2. Engage the parking brake and move the function-control switch to the NEUTRAL position.
3. Ensure that the cutting units are disengaged and lower them to the ground.
4. Shut off the machine and remove the key.
5. Disconnect the power from the machine by separating the main-power connectors; refer to [Main-Power Connectors \(page 20\)](#).
6. Ensure that the connectors are free of dust and debris.
7. Slide the charger-output connector into the charger connector on the machine ([Figure 33](#)).

Note: The machine connector is located below the main-power connector that is secured to the machine.

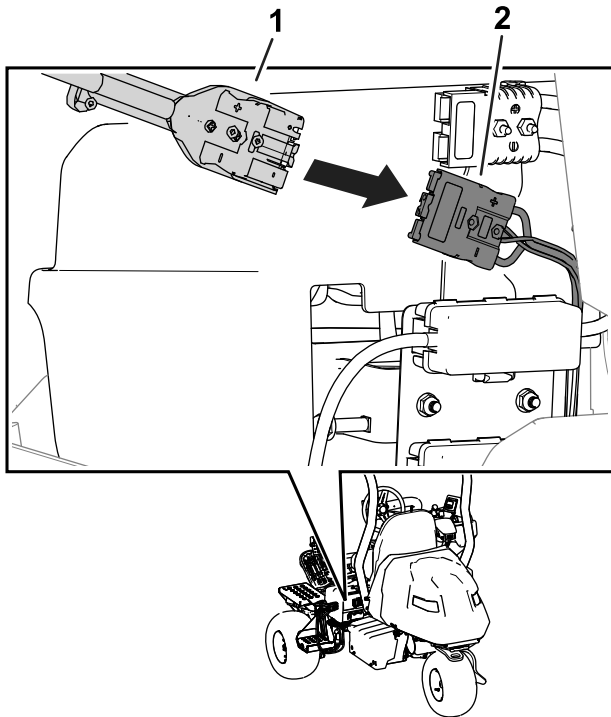

Figure 33

g292546

1. Charger connector
2. Machine connector

8. Connect the charger power cord to a power source; refer to [Connecting to a Power Source \(page 35\)](#).

9. Observe the charger to ensure that the batteries are charging.

Note: The battery-charging indicator light should be flashing and the charging-output indicator light should illuminate.

10. Disconnect the charger when the machine reaches a sufficient level; refer to [Completing the Charging Process \(page 36\)](#).

Monitoring the Charging Process and Troubleshooting

Note: The LCD status display displays messages during the course of charging. Most are routine.

If there is a fault, the error indicator light will flash amber or a solid, light red. An error message will appear in the InfoCenter 1 digit at a time, starting with the letter E or F (e.g., E-0-1-1).

To correct an error, refer to [Troubleshooting \(page 52\)](#). If none of these solutions correct the issue, contact an authorized Toro distributor.

Completing the Charging Process

When charging is complete, the battery-charging indicator light ([Figure 32](#)) shows solid green and the charging-output indicator light disappears.

1. Disconnect the charger connector from the machine connector.
2. Place the charger connector and cord in a storage position that avoids damage.
3. Ensure that the main-power connectors are clean.
4. Connect the main-power connectors; refer to [Main-Power Connectors \(page 20\)](#).
5. Turn on the machine; refer to [Turning On the Machine \(page 27\)](#).
6. Verify the charge level; refer to [Using the InfoCenter LCD Display \(page 16\)](#).

Maintenance

Maintenance Safety

- Before you leave the operator's position, do the following:
 - Park the machine on a level surface.
 - Move the function-control switch to the NEUTRAL position.
 - Ensure that the cutting units are disengaged and lower them to the ground.
 - Engage the parking brake.
 - Shut off the machine and remove the key.
 - Wait for all movement to stop.
- Allow machine components to cool before performing maintenance.
- Only allow a qualified repair person to service the machine.
- Disconnect the main-power connectors before performing maintenance.
- If possible, do not perform maintenance while the machine is running. Keep away from moving parts.
- Support the machine with jack stands whenever you work under the machine.
- Carefully release pressure from components with stored energy.
- Keep all parts of the machine in good working condition and all hardware tightened.
- Replace all worn or damaged decals.
- To ensure safe, optimal performance of the machine, use only genuine Toro replacement parts. Replacement parts made by other manufacturers could be dangerous, and such use could void the product warranty.

Recommended Maintenance Schedule(s)

Maintenance Service Interval	Maintenance Procedure
After the first 8 hours	<ul style="list-style-type: none">• Torque the wheel nuts.• Change the traction-motor-gearbox fluid.
Before each use or daily	<ul style="list-style-type: none">• Inspect the seat belt(s) for wear, cuts, and other damage. Replace the seat belt(s) if any component does not operate properly.• Check the safety-interlock system.• Inspect and cleanup after mowing.• Check the tire pressure.• Check the reel-to-bedknife contact.• Wash the machine (do not use high-pressure water).
Every 50 hours	<ul style="list-style-type: none">• Check the battery cable connections.
Every 200 hours	<ul style="list-style-type: none">• Torque the wheel nuts.
Every 800 hours	<ul style="list-style-type: none">• Change the traction-motor-gearbox fluid.

Daily Maintenance Checklist

Duplicate this page for routine use.

Maintenance Check Item	For the week of:						
	Mon.	Tues.	Wed.	Thurs.	Fri.	Sat.	Sun.
Check the safety-interlock operation.							
Check the instrument operation.							
Check the brake operation.							
Check the tire pressure.							
Check the reel-to-bedknife contact.							
Check the height-of-cut adjustment.							
Touch-up damaged paint.							
Wash the machine.							

Notation for Areas of Concern		
Inspection performed by:		
Item	Date	Information

Pre-Maintenance Procedures

Raising the Machine

⚠ DANGER

Mechanical or hydraulic jacks may fail to support the machine and cause a serious injury.

- Use jack stands to support the raised machine.
 - Use only mechanical or hydraulic jacks to lift the machine.
1. Position a jack at the desired jacking point ([Figure 34](#)):
 - Foot step on the left side of the machine
 - Jack bracket on the right side of the machine
 - Caster fork on the rear of the machine

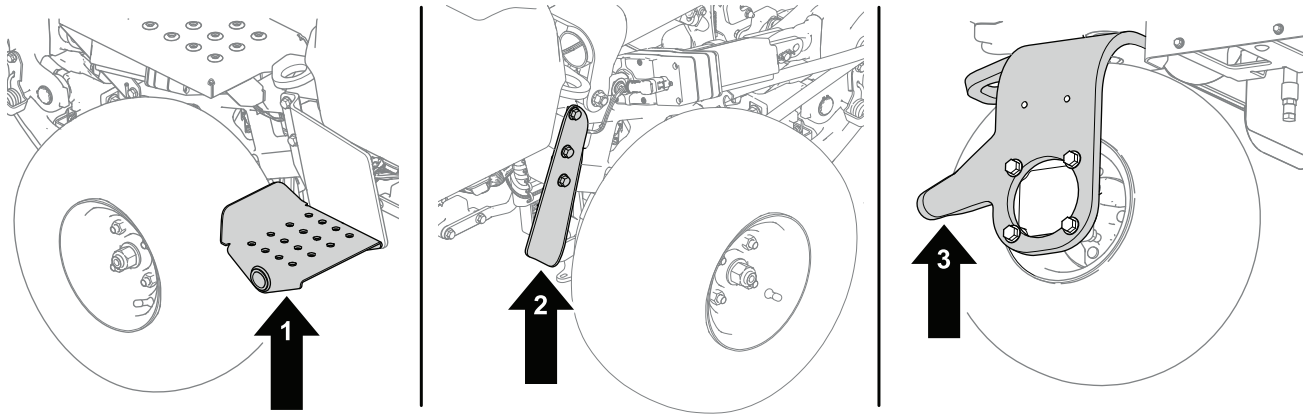

g286954

Figure 34

1. Foot step—left side of the machine
2. Caster fork—rear of the machine
3. Jack bracket—right side of the machine

2. After raising the machine, use an appropriate jack stand under the following areas to support the machine (Figure 35):

- Battery trays at the rear of the machine
- Cutting-unit pivot mounts at the front of the machine

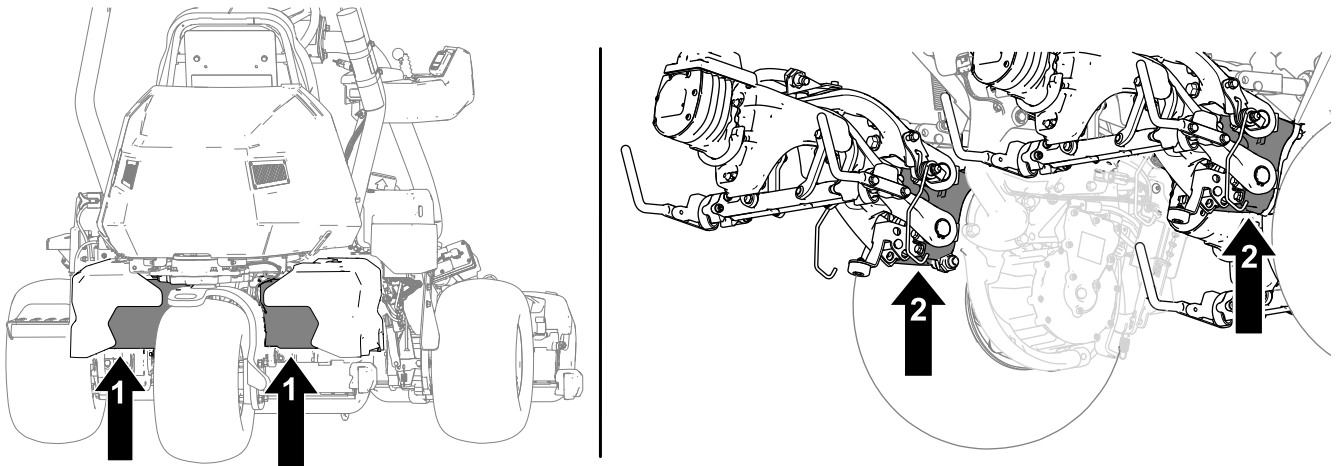

g296353

Figure 35

1. Battery trays
2. Cutting-unit pivot mounts

Raising the Hood

1. Release the straps from each side of the hood ([Figure 36](#)).

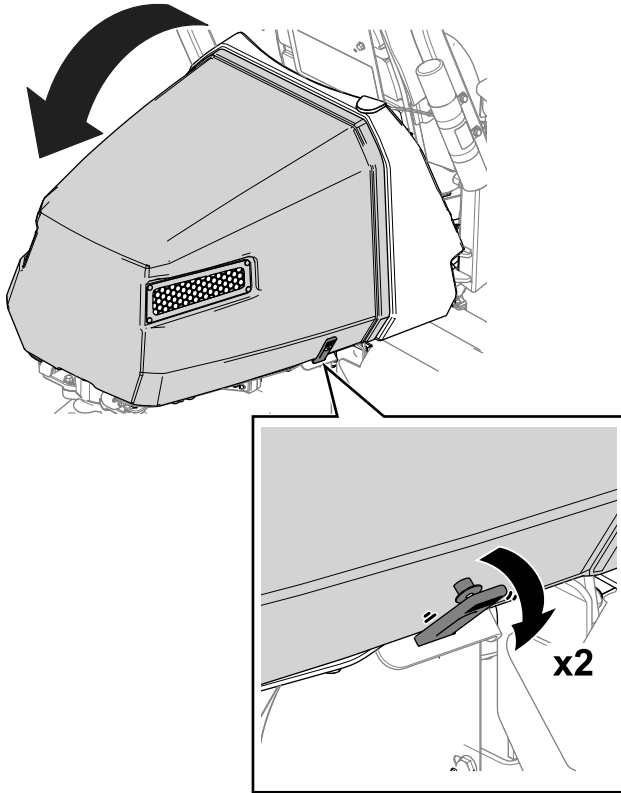

Figure 36

g292114

-
2. Raise the hood ([Figure 36](#)).

Electrical System Maintenance

Electrical System Safety

- Disconnect the main-power connectors before repairing the machine.
- Charge the battery in an open, well-ventilated area, away from sparks and flames. Unplug the charger before connecting or disconnecting the battery. Wear protective clothing and use insulated tools.

Disconnecting or Connecting Power to the Machine

The main-power connectors provide power from the batteries to the machine. Disconnect the power by separating the connectors; connect the power by installing the connectors together. Refer to [Main-Power Connectors \(page 20\)](#).

Locating the Fuses

Locating the Fuses for the 48V System

The fuses in the 48V electrical system are located under the seat (Figure 37).

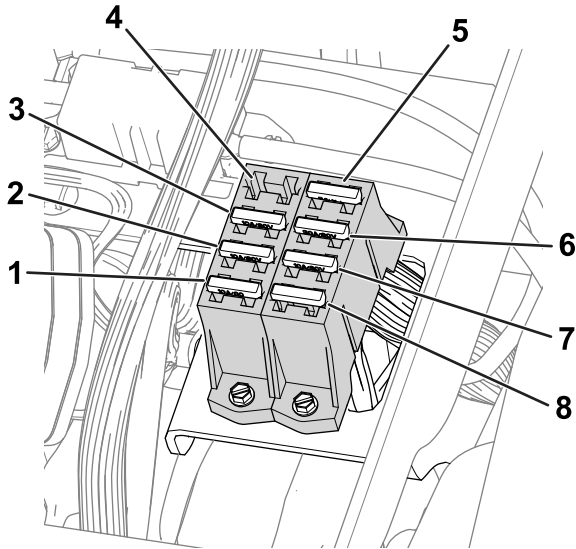

Figure 37

g288685

- | | |
|---|------------------------------------|
| 1. Lift actuator (center cutting unit)—10 A | 5. 48V logic relay—5 A |
| 2. Lift actuator (left cutting unit)—10 A | 6. Steering unit—30 A |
| 3. Lift actuator (right cutting unit)—10 A | 7. DC/DC converter—10 A |
| 4. Open slot | 8. Work lights (optional kit)—10 A |

Locating the Fuses for the 12V System

The fuses for the 12V electrical system are located under the cover (Figure 38) on the right side of the machine.

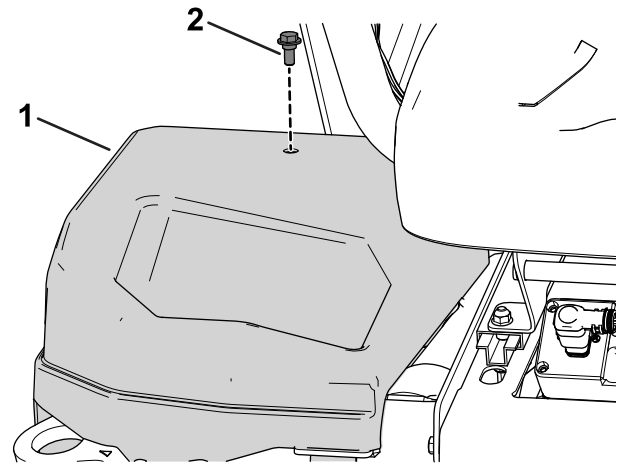

Figure 38

g279712

- | | |
|---------------------|---------|
| 1. Right-side cover | 2. Bolt |
|---------------------|---------|

Refer to Figure 39 for a description of each fuse on the fuse blocks:

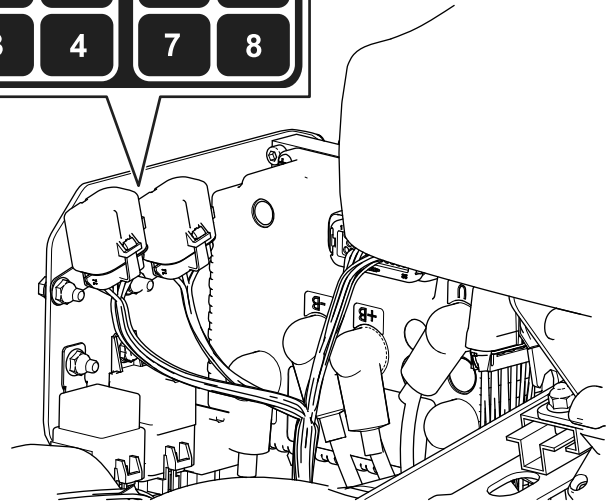

Figure 39

g279711

- | | |
|---|-------------------------|
| 1. Parking brake/key switch/logic relay—7.5 A | 5. Open slot |
| 2. Open slot | 6. Spare fuse—7.5 A |
| 3. Brake actuator—10 A | 7. DC/DC converter—15 A |
| 4. Telematics—2 A | 8. TEC controller—2 A |

Locating the Reel-Drive Circuit Fuses

The fuses for the reel-drive circuit are located under the cover on the left side of the machine. Access the fuse block by removing the left-side cover and the fuse-block cover (Figure 40).

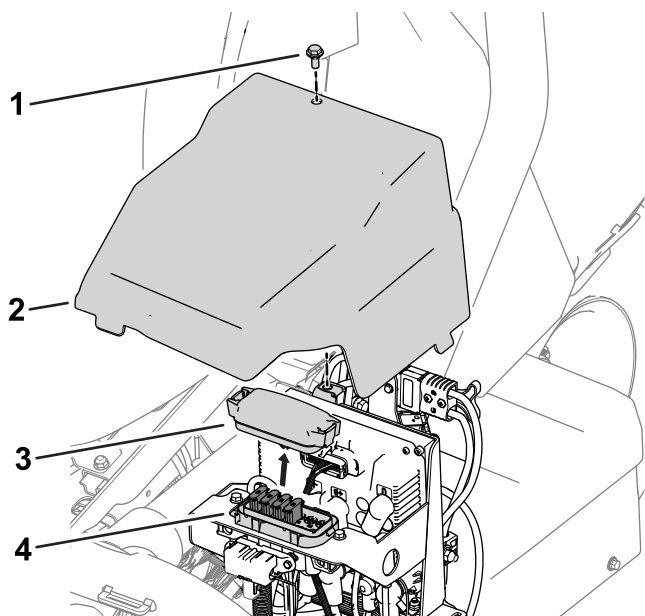

Figure 40

- | | |
|--------------------|---------------------|
| 1. Bolt | 3. Fuse-block cover |
| 2. Left-side cover | 4. Fuse block |

Refer to Figure 41 for a description of each fuse on the fuse-block decal:

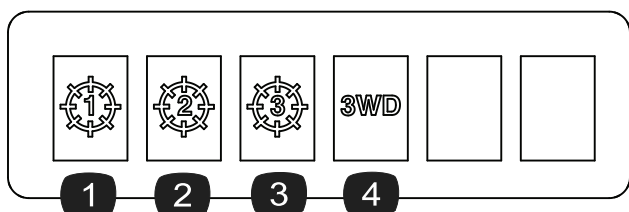

Figure 41

- | | |
|---------------------------------|---|
| 1. Center cutting unit—35 A | 3. Front right cutting unit—35 A |
| 2. Front left cutting unit—35 A | 4. 3-Wheel Drive Kit (optional attachment)—35 A |

Locating the Precharge Controller Fuse

The fuse that protects the precharge controller is located in its own holder on the machine wire harness to the left of the center (rear) battery set (Figure 42).

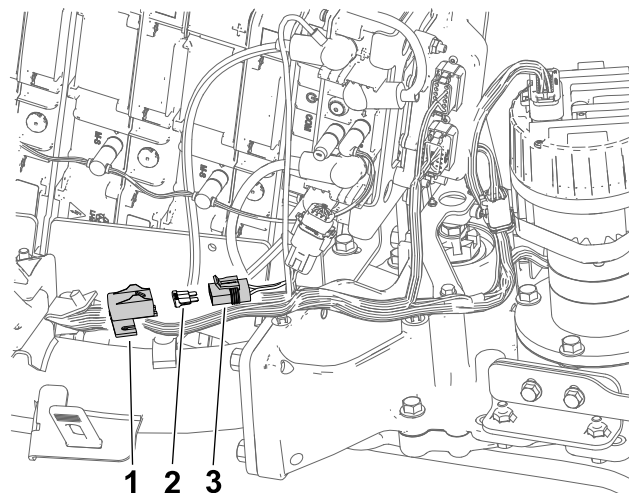

Figure 42

- | | |
|----------------------------------|----------------|
| 1. Cap | 3. Fuse holder |
| 2. Precharge controller fuse—3 A | |

Locating the Wheel Motor and Electrical System Fuses

- The fuses for the right wheel motor (60 A) are located under the seat (Figure 43).

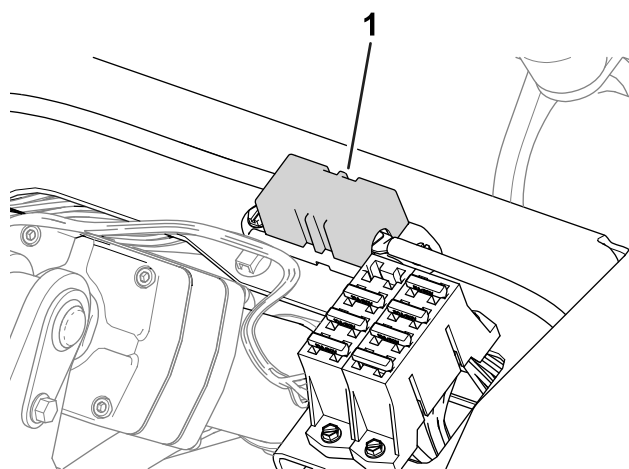

Figure 43

- | |
|--------------------------------|
| 1. Right-wheel-motor fuse—60 A |
|--------------------------------|

- The fuse for the left wheel motor (60 A) is located under the cover on the left side of the machine, near the reel-drive-circuit fuses (Figure 44).

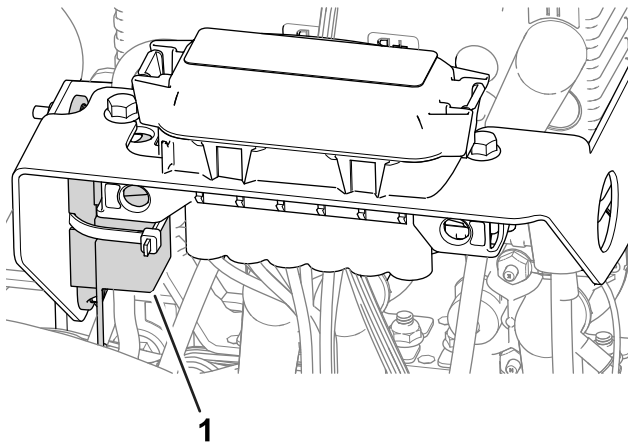

Figure 44

g282896

1. Left-wheel-motor fuse—60 A

- The fuse for the electrical system is located under the main-power connectors (Figure 45).

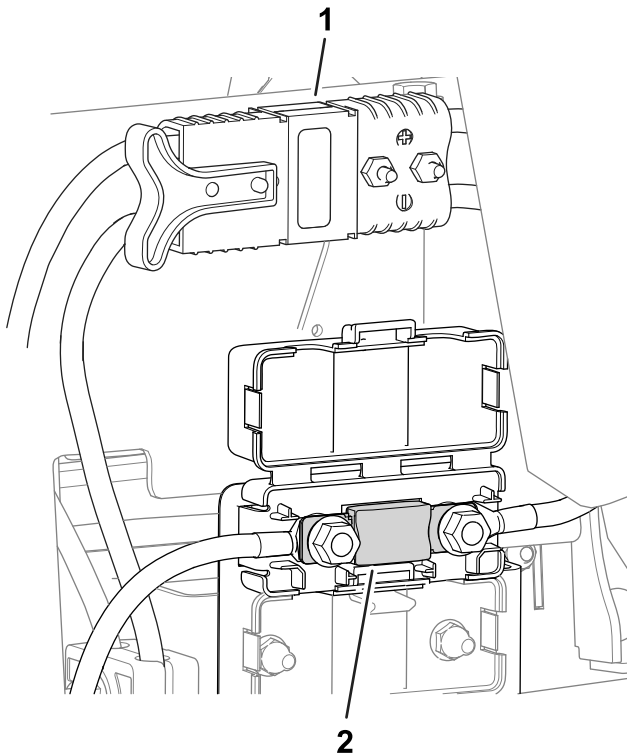

Figure 45

g296483

1. Main-power connectors
2. Electrical-system fuse—175 A

Servicing the Batteries

Note: The machine is equipped with 8 lithium-ion batteries.

A lithium-ion battery must be disposed of or recycled in accordance with local and federal regulations. If a battery requires service, contact your authorized Toro distributor for assistance.

The only user serviceable parts on a battery are the labels. If you attempt to open the main compartment of a battery, you will void your warranty. If you are having problems with a battery, contact your authorized Toro distributor for assistance.

Maintaining the Battery Charger

Important: All electrical repairs should be performed by an authorized Toro distributor only.

You need only to protect the charger from damage and weather.

Maintaining the Battery-Charger Cords

- Clean the cords with a slightly damp cloth after each use.
- Coil the cords when not in use.
- Periodically examine the cords for damage, and replace them when necessary with Toro-approved parts.

Cleaning the Battery-Charger Case

Clean the case with a slightly damp cloth after each use.

Drive System Maintenance

Checking the Tire Pressure

Service Interval: Before each use or daily

Vary the tire pressure for all 3 wheels, depending upon your turf conditions, from a minimum of 83 to a maximum of 110 kPa (12 psi to 16 psi).

Important: Ensure that the tire pressure for each wheel is identical. If the tire pressure for each wheel is different, the performance of the machine is affected.

Checking the Torque of the Wheel Nuts

Service Interval: After the first 8 hours

Every 200 hours

⚠ WARNING

Failure to maintain proper torque of the wheel nuts could result in personal injury.

Torque the wheel nuts to the specified torque at the specified intervals.

Wheel-nut torque specification: 108 to 122 N·m (80 to 90 ft-lb)

To ensure even distribution, torque the wheel nuts in the pattern shown in [Figure 46](#).

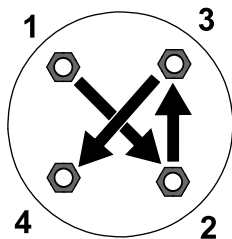

Figure 46

g274650

Changing the Traction-Motor-Gearbox Fluid

Service Interval: After the first 8 hours

Every 800 hours

Fluid specification: SAE 80W90

Gearbox oil capacity: approximately 384 ml (13 fl oz)

1. Raise the machine; refer to [Raising the Machine](#) (page 38).

Important: The machine must be level so that the correct amount of fluid can be added to the gearbox.

Ensure that the machine is level on the jack stands.

2. Perform the following steps to remove the left and right-sided tires:
 - A. Loosen and remove the wheel lug nuts ([Figure 47](#)).

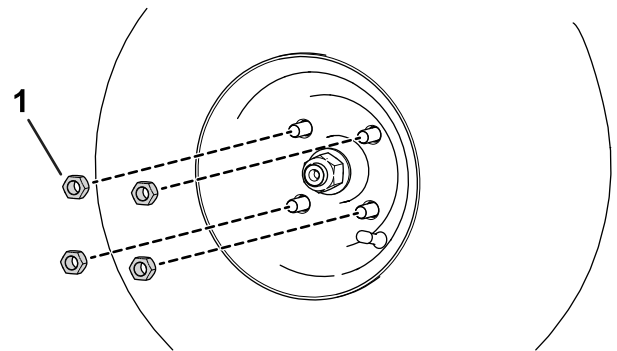
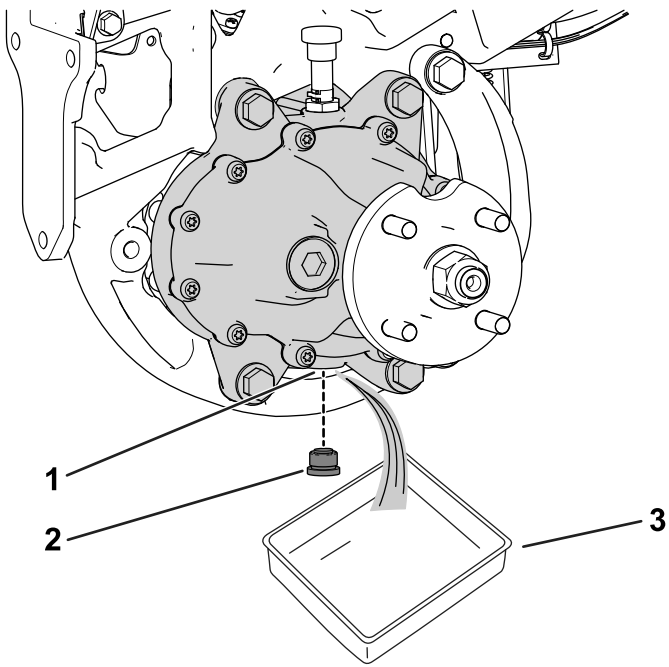

Figure 47

g280226

1. Lug nut

-
- B. Remove the left and right tires.
3. Place a drain pan under the wheel-motor assembly ([Figure 48](#)).



g322517

Figure 48

Left side of the machine shown

- | | |
|---------------|--------|
| 1. Drain port | 3. Pan |
| 2. Drain plug | |

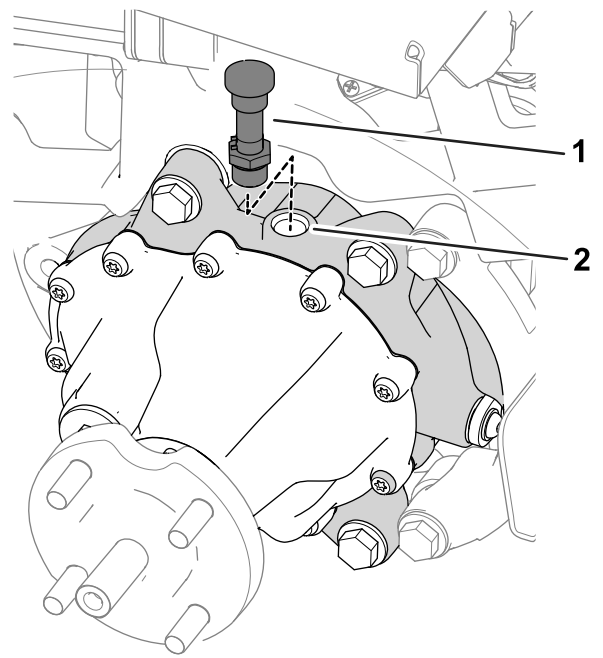

g322518

Figure 49

- | | |
|--------------------------|--------------|
| 1. Vent hose and fitting | 2. Fill port |
|--------------------------|--------------|

-
4. Remove the plug from the drain port (Figure 48).

Note: The drain port is located on the bottom of the gearbox.

Note: Allow the oil to drain completely from the gearbox.

5. Clean the plug.
6. Install the drain plug into the drain port (Figure 48).
7. Remove the vent hose and fitting from the top of the gearbox (Figure 49).

-
8. Fill the gearbox with 384 ml (13 fl oz) of the specified fluid through the fill port.
 9. Install the vent hose and fitting into the fill port (Figure 49).
 10. Perform the following steps to install the tires:
 - A. Slide the left and right tires on to the wheel hubs.
 - B. Install the wheel lug nuts (Figure 47).
 - C. Torque the wheel lug nuts to the specified torque indicated in [Checking the Torque of the Wheel Nuts](#) (page 44).

Brake Maintenance

Adjusting the Brakes

If the brake fails to hold the machine while parked, you can adjust the brakes; contact your authorized Toro distributor or refer to the *Service Manual* for more information.

Cutting Unit Maintenance

Blade Safety

A worn or damaged blade or bedknife can break, and a piece could be thrown toward you or bystanders, resulting in serious personal injury or death.

- Inspect the blades and bedknives periodically for excessive wear or damage.
- Use care when checking the blades. Wear gloves and use caution when servicing them. Only replace or backlap the blades and bedknives; never straighten or weld them.
- On machines with multiple cutting units, take care when rotating a cutting unit; it can cause the reels in the other cutting units to rotate.

Installing and Removing the Cutting Units

Note: When the cutting units are not connected to the machine, store the cutting unit reel motors in the storage location on the front of the suspension arms to prevent damage to them.

Important: Do not raise the suspension to the transport position when the reel motors are in the holders in the machine frame. Damage to the motors or hoses could result.

Important: Whenever you need to tip the cutting unit, prop up rear of cutting unit to ensure that the nuts on the bedbar adjusting screws are not resting on work surface (**Figure 50**).

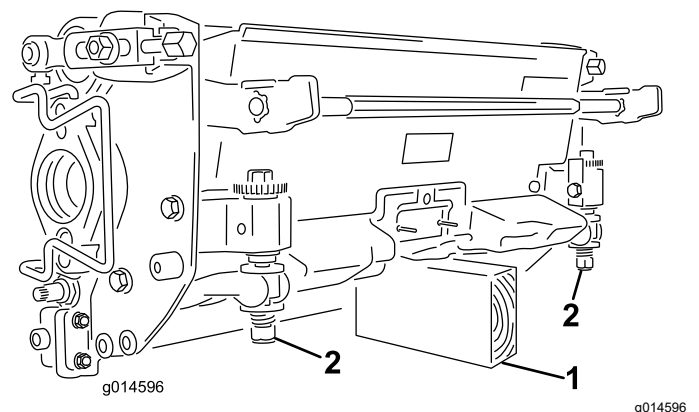

Figure 50

1. Prop (not provided)
2. Bedbar-adjusting-screw nut

Installing the Cutting Units

The suspension needs to be lowered in order to install the cutting units. Perform the following steps to lower the suspension:

1. Park the machine on a clean, level surface.
2. Set the function-control switch to the NEUTRAL position.
3. Insert the key into the switch and turn it to the ON position.
4. Lower the suspension using the lift/lower joystick.
5. Engage the parking brake, shut off the machine, and remove the key.

Perform the following steps to install the cutting units:

1. Disconnect the main-power connectors; refer to [Main-Power Connectors](#) (page 20).

⚠ CAUTION

If you do not disconnect the power to the machine, someone could accidentally start the cutting units, causing serious injury to hands and feet.

Always disconnect the main-power connectors before working on the cutting units.

2. Lift up on the foot rest and swing it open, allowing access to the center cutting unit position ([Figure 51](#)).

⚠ CAUTION

The foot rest can pinch fingers if it falls into the closed position.

Keep your fingers clear of the area where the foot rest seats while it is open.

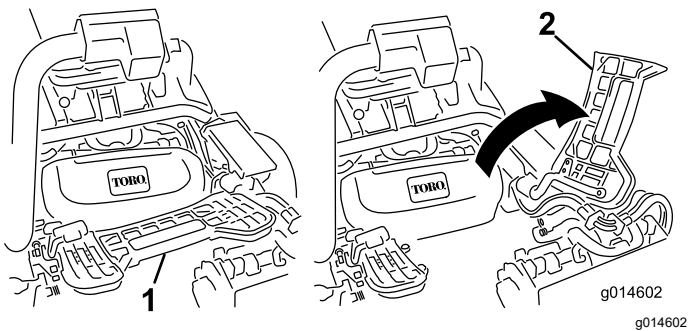

Figure 51

1. Footrest—closed
2. Footrest—open

3. Position the cutting unit under the center suspension arm.

4. Open the latches on the suspension-arm bar ([Figure 52](#)) and push the suspension arm down so that the bar fits over both pitch arms on the cutting unit and ensure that the latches go underneath the cutting-unit crossbar ([Figure 53](#)).

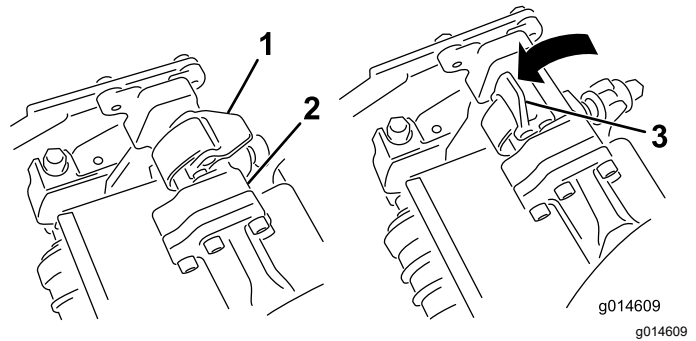

Figure 52

1. Latch—closed
2. Suspension-arm bar
3. Latch—open

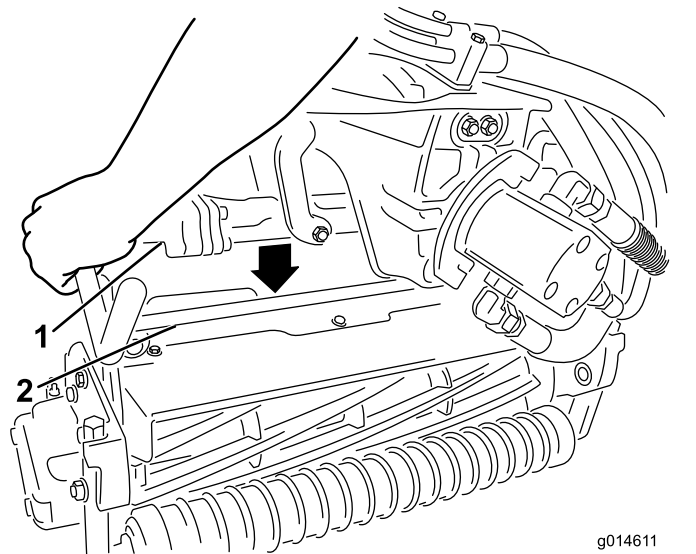

Figure 53

1. Suspension-arm bar
2. Cutting-unit bar

5. Close the latches down and around the cutting-unit bar and lock them in place ([Figure 52](#)).

Note: You can hear a click and feel when the latches are properly locked in place.

6. Coat the spline shaft of the cutting unit motor with clean grease ([Figure 54](#)).
7. Insert the motor into the left side of the cutting unit (as viewed from the operator's position) and pull the motor retaining bar on the cutting unit toward the motor until you hear a click from both sides of the motor ([Figure 54](#)).

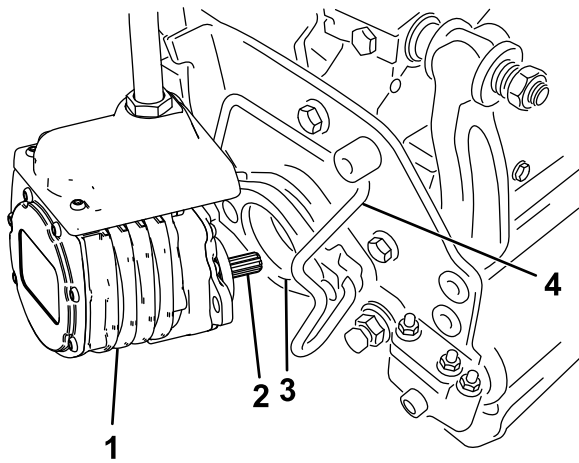

Figure 54

- | | |
|-----------------|------------------------|
| 1. Reel motor | 3. Cavity |
| 2. Spline shaft | 4. Motor-retaining bar |

⚠ CAUTION

If you do not disconnect the power to the machine, someone could accidentally start the cutting units, causing serious injury to hands and feet.

Always separate the disconnect the main-power connectors before working on the cutting units.

4. Push the motor retaining bar out of the slots on the motor toward the cutting unit and remove the motor from the cutting unit.

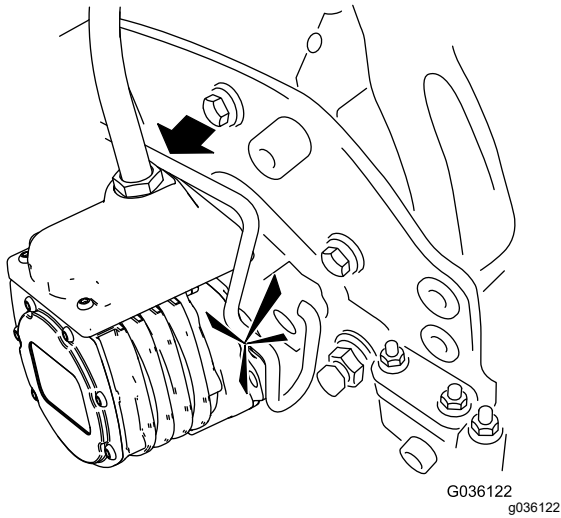

Figure 55

1. Reel motor
2. Motor-retaining bar

8. Mount a grass basket onto the basket hooks on the suspension arm.
9. Repeat this procedure for the other cutting units.
10. Connect the main-power connectors; refer to [Main-Power Connectors \(page 20\)](#).

Removing the Cutting Units

1. Park the machine on a clean, level surface, set the function-control switch to the NEUTRAL position and use the lift/lower joystick to lower the cutting units.
2. Engage the parking brake, shut off the machine, and remove the key.
3. Disconnect the main-power connectors; refer to [Main-Power Connectors \(page 20\)](#).

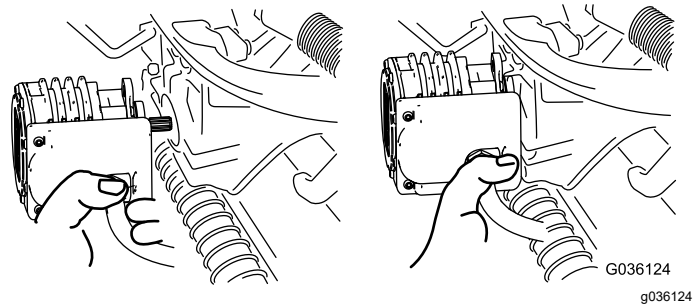

Figure 56

Note: When sharpening, setting the height-of-cut, or performing other maintenance procedures on the cutting units, store the cutting unit reel motors in the storage location on the front of the suspension arms to prevent damage to them.

Important: Do not raise the suspension to the transport position when the reel motors are in the holders in the machine frame. Damage to the motors or wires could result. If you must move the traction unit without the cutting units installed, secure them to the suspension arms using cable ties.

6. Open the latches on the suspension-arm bar of the cutting unit you are removing (Figure 52).
7. Disconnect the latches from the cutting-unit bar.
8. Roll the cutting unit out from under the suspension arm.
9. Repeat steps 4 through 8 for the other cutting units as required.
10. Connect the main-power connectors; refer to [Main-Power Connectors](#) (page 20).

Checking the Reel-to-Bedknife Contact

Each day before operating the machine, check the reel-to-bedknife contact, regardless if the quality of cut had previously been acceptable. There must be light contact across the full length of the reel and bedknife; refer to the cutting unit *Operator's Manual*.

Before checking the reels, disconnect the main-power connectors; refer to [Main-Power Connectors](#) (page 20). Connect them when finished.

Backlapping the Cutting Units

⚠ WARNING

Contact with the bedknives, reel blades, or other moving parts can result in personal injury.

- Keep your fingers, hands, and clothing away from the bedknives, reel blades, or moving parts.
- Never attempt to turn the reels by hand or foot while the machine is running.

1. Park the machine on a level surface, lower the cutting units, move the function-control switch to the NEUTRAL position, engage the parking brake, shut off the machine, and remove the key.
2. Make initial reel-to-bedknife adjustments appropriate for backlapping on all cutting units that you want to backlap; refer to the cutting unit *Operator's Manual*.

3. Insert the key into the switch and turn on the machine.
4. On the InfoCenter control, from the SERVICE menu, select BACKLAP.
5. Set BACKLAP to ON.
6. Pull up the Main Menu and scroll down to Settings.
7. In the SETTINGS menu scroll down to BACKLAP RPM and use the ± button to select the desired backlap speed.
8. With the function-control switch in the NEUTRAL position, move the lift/lower joystick forward to start the backlapping operation on the designated reels.
9. Apply lapping compound with a long handle brush. Never use a short handled brush.
10. If the reels stall or become erratic while backlapping, select a higher reel speed setting until the speed stabilizes.
11. To make an adjustment to the cutting units while backlapping, turn the reels off by moving the lift/lower joystick rearward, then shut off the machine. After completing adjustments, repeat steps 3 through 9.
12. Repeat the procedure for all cutting units that you want to backlap.
13. When finished, return the InfoCenter BACKLAP setting to OFF or turn the key to the OFF position to return the machine to forward cutting operation.
14. Wash all lapping compound off of the cutting units. Adjust the cutting unit reel to bedknife as needed. Move the cutting-unit reel speed control to the desired mowing position.

Important: Do not use high pressure water to clean off the cutting units. Damage to the bearings and seals may result.

Storage

If you wish to store the machine for a long period of time, perform the steps listed in [Preparing the Machine for Storage](#) (page 50).

Storage Safety

- Lower the cutting units, engage the parking brake, shut off the machine, remove the key, and wait for all movement to stop before you leave the operator's position. Allow the machine to cool before adjusting, servicing, cleaning, or storing it.
- Do not store the machine where there is an open flame, spark, or pilot light, such as on a water heater or other appliance.
- Store the machine in a dry location indoors, out of the reach of children and away from direct sunlight.

Preparing the Machine for Storage

1. Always shut off the machine, remove the key, wait for all moving parts to stop, and allow the machine to cool before adjusting, cleaning, storing, or repairing the machine.
2. Remove accumulations of dirt and old grass clippings. Sharpen the reels and bedknives, if necessary; refer to the cutting unit *Operator's Manual*. Coat the bedknives and reel blades with a rust preventive.
3. Raise and support the machine to remove its weight from the tires.
4. For prolonged storage, follow the battery storage requirements; refer to [Battery Storage Requirements](#) (page 50).

Battery Storage Requirements

Note: You do not need to remove the batteries from the machine for storage.

Refer to the temperature requirements for storage in the following table:

Temperature Requirements for Storage

Storage Conditions	Temperature Requirement
Normal storage conditions	-20° to 45°C (-12° to 113°F)
Extreme heat—1 month or less	45° to 60°C (113° to 140°F)
Extreme cold—3 months or less	-30° to -20°C (-22° to -12°F)

Important: Temperatures outside of this range will damage your batteries.

The temperature that the batteries are stored at will affect their long-term life. Storage for long periods of time at extreme temperatures will reduce the battery life. Store the machine in the normal storage conditions indicated in the temperature-requirements table.

- Before you store the machine, charge or discharge the batteries between 40% to 60% (50.7V to 52.1V).

Note: A 50% charge is optimal to ensure a maximum battery life. When the batteries are charged to 100% before storage, the battery life shortens.

If you anticipate that the machine will be stored for a longer period of time, charge the batteries to around 60%.

- For every 6 months of storage, check the battery-charge level and ensure that it is between 40% to 60%. If the charge is below 40%, charge the batteries between 40% to 60%.
- You can use a multimeter to check the charge level when the machine is off. Refer to the following table for the amount of voltage that is equal to the charge level:

Voltage	Charge Level
52.1V	60%
51.4V	50%
50.7V	40%

- After charging the batteries, disconnect the battery charger from power. Disconnect the power connector during storage to minimize the discharging of the batteries.
- If you leave the charger on the machine, it will shut off after the batteries are fully charged and

does not turn back on unless the charger is disconnected and reconnected.

Storing the Charger

1. Disconnect the power to the machine; refer to [Disconnecting or Connecting Power to the Machine \(page 40\)](#).
2. Disconnect the power supply cord from the charger and coil it securely.
3. Examine the power supply cord thoroughly for signs of wear or damage. Replace it if it is worn or damaged.
4. Examine the charger thoroughly for worn, loose, or damaged parts. To repair or replace parts, contact your authorized Toro distributor for assistance.
5. Store the charger with the power supply cord in a clean, dry place where it will not be bumped or damaged and not exposed to caustic fumes.

Troubleshooting

Battery-Charger Error Codes

Problem	Possible Cause	Corrective Action
Code E-0-0-1, or E-0-4-7	1. Battery high voltage	1. Ensure that the battery voltage is correct and the cable connections are secure; ensure that the battery is in good condition.
Code E-0-0-4	1. BMS or battery fault detected	1. Contact an authorized Toro distributor.
Code E-0-0-7	1. Battery amp hour limit exceeded	1. Possible causes include poor battery health, very deeply discharged battery, poorly connected battery, and/or high parasitic loads on battery while charging. Possible solutions: Replace batteries. Check DC connections. Disconnect parasitic loads. This error will clear once the charger is reset by cycling DC.
Code E-0-1-2	1. Reverse polarity error	1. The battery is connected to the charger incorrectly. Ensure that the battery connections are secure.
Code E-0-2-3	1. High AC voltage error (>270VAC)	1. Connect charger to an AC source that provides stable AC between 85 - 270 VAC / 45-65 Hz.
Code E-0-2-4	1. Charger failed to initialize	1. The charger failed to turn on properly. Disconnect the AC input and battery connection for 30 seconds before retrying.
Code E-0-2-5	1. Low AC voltage oscillation error	1. The AC source is unstable. Could be caused by undersized generator or severely undersized input cables. Connect charger to an AC source that provides stable AC between 85 - 270 VAC / 45-65 Hz.
Code E-0-3-7	1. Re-programming failed	1. Software upgrade failure or script operation failure. Ensure that the new software is correct.
Code E-0-2-9, E-0-3-0, E-0-3-2, E-0-4-6, or E-0-6-0	1. Communication error with battery	1. Ensure that the connection of the signal wires to the battery is secure.

Battery-Charger Fault Codes

Problem	Possible Cause	Corrective Action
F-0-0-1, F-0-0-2, F-0-0-3, F-0-0-4, F-0-0-5, F-0-0-6, or F-0-0-7	1. Internal charger fault	1. Remove the AC connection and battery connection for a minimum of 30 seconds and retry. If it fails again, please contact an authorized Toro distributor.

EEA/UK Privacy Notice

Toro's Use of Your Personal Information

The Toro Company ("Toro") respects your privacy. When you purchase our products, we may collect certain personal information about you, either directly from you or through your local Toro company or dealer. Toro uses this information to fulfil contractual obligations - such as to register your warranty, process your warranty claim or to contact you in the event of a product recall - and for legitimate business purposes - such as to gauge customer satisfaction, improve our products or provide you with product information which may be of interest. Toro may share your information with our subsidiaries, affiliates, dealers or other business partners in connection these activities. We may also disclose personal information when required by law or in connection with the sale, purchase or merger of a business. We will never sell your personal information to any other company for marketing purposes.

Retention of your Personal Information

Toro will keep your personal information as long as it is relevant for the above purposes and in accordance with legal requirements. For more information about applicable retention periods please contact legal@toro.com.

Toro's Commitment to Security

Your personal information may be processed in the US or another country which may have less strict data protection laws than your country of residence. Whenever we transfer your information outside of your country of residence, we will take legally required steps to ensure that appropriate safeguards are in place to protect your information and to make sure it is treated securely.

Access and Correction

You may have the right to correct or review your personal data, or object to or restrict the processing of your data. To do so, please contact us by email at legal@toro.com. If you have concerns about the way in which Toro has handled your information, we encourage you to raise this directly with us. Please note that European residents have the right to complain to your Data Protection Authority.



Battery Limited Warranty

4 years

Battery

The rechargeable Lithium-Ion battery is warranted to be free from defects in materials and workmanship for a period of 4 years. Over time, battery consumption reduces the amount of energy capacity (Amp-hours) available per full charge. Energy consumption varies due to operating characteristics, accessories, turf, terrain, adjustments, and temperature.

Tier	Years	Days
1	≤2	0-730
2	≤2.5	731-910
3	≤3	911-1095
4	≤3.5	1096-1275
5	≤4	1276-1460



The Toro Warranty

Two-Year or 1,500 Hours Limited Warranty

Conditions and Products Covered

The Toro Company warrants your Toro Commercial product ("Product") to be free from defects in materials or workmanship for 2 years or 1,500 operational hours*, whichever occurs first. This warranty is applicable to all products with the exception of Aerators (refer to separate warranty statements for these products). Where a warrantable condition exists, we will repair the Product at no cost to you including diagnostics, labor, parts, and transportation. This warranty begins on the date the Product is delivered to the original retail purchaser.

* Product equipped with an hour meter.

Instructions for Obtaining Warranty Service

You are responsible for notifying the Commercial Products Distributor or Authorized Commercial Products Dealer from whom you purchased the Product as soon as you believe a warrantable condition exists. If you need help locating a Commercial Products Distributor or Authorized Dealer, or if you have questions regarding your warranty rights or responsibilities, you may contact us at:

Toro Commercial Products Service Department
8111 Lyndale Avenue South
Bloomington, MN 55420-1196

952-888-8801 or 800-952-2740
E-mail: commercial.warranty@toro.com

Owner Responsibilities

As the product owner, you are responsible for required maintenance and adjustments stated in your *Operator's Manual*. Repairs for product issues caused by failure to perform required maintenance and adjustments are not covered under this warranty.

Items and Conditions Not Covered

Not all product failures or malfunctions that occur during the warranty period are defects in materials or workmanship. This warranty does not cover the following:

- Product failures which result from the use of non-Toro replacement parts, or from installation and use of add-on, or modified non-Toro branded accessories and products.
- Product failures which result from failure to perform recommended maintenance and/or adjustments.
- Product failures which result from operating the Product in an abusive, negligent, or reckless manner.
- Parts consumed through use that are not defective. Examples of parts which are consumed, or used up, during normal Product operation include, but are not limited to, brake pads and linings, clutch linings, blades, reels, rollers and bearings (sealed or greasable), bed knives, spark plugs, castor wheels and bearings, tires, filters, belts, and certain sprayer components such as diaphragms, nozzles, flow meters, and check valves.
- Failures caused by outside influence, including, but not limited to, weather, storage practices, contamination, use of unapproved fuels, coolants, lubricants, additives, fertilizers, water, or chemicals.
- Failure or performance issues due to the use of fuels (e.g. gasoline, diesel, or biodiesel) that do not conform to their respective industry standards.
- Normal noise, vibration, wear and tear, and deterioration. Normal "wear and tear" includes, but is not limited to, damage to seats due to wear or abrasion, worn painted surfaces, scratched decals or windows.

Countries Other than the United States or Canada

Customers who have purchased Toro products exported from the United States or Canada should contact their Toro Distributor (Dealer) to obtain guarantee policies for your country, province, or state. If for any reason you are dissatisfied with your Distributor's service or have difficulty obtaining guarantee information, contact your Authorized Toro Service Center.

Parts

Parts scheduled for replacement as required maintenance are warranted for the period of time up to the scheduled replacement time for that part. Parts replaced under this warranty are covered for the duration of the original product warranty and become the property of Toro. Toro will make the final decision whether to repair any existing part or assembly or replace it. Toro may use remanufactured parts for warranty repairs.

Deep Cycle and Lithium-Ion Battery Warranty

Deep cycle and Lithium-Ion batteries have a specified total number of kilowatt-hours they can deliver during their lifetime. Operating, recharging, and maintenance techniques can extend or reduce total battery life. As the batteries in this product are consumed, the amount of useful work between charging intervals will slowly decrease until the battery is completely worn out. Replacement of worn out batteries, due to normal consumption, is the responsibility of the product owner. Note: (Lithium-Ion battery only): Refer to the battery warranty for additional information.

Lifetime Crankshaft Warranty (ProStripe 02657 Model Only)

The ProStripe which is fitted with a genuine Toro Friction Disc and Crank-Safe Blade Brake Clutch (integrated Blade Brake Clutch (BBC) + Friction Disc assembly) as original equipment and used by the original purchaser in accordance with recommended operating and maintenance procedures, are covered by a Lifetime Warranty against engine crankshaft bending. Machines fitted with friction washers, Blade Brake Clutch (BBC) units and other such devices are not covered by the Lifetime Crankshaft Warranty.

Maintenance is at Owner's Expense

Engine tune-up, lubrication, cleaning and polishing, replacement of filters, coolant, and completing recommended maintenance are some of the normal services Toro products require that are at the owner's expense.

General Conditions

Repair by an Authorized Toro Distributor or Dealer is your sole remedy under this warranty.

The Toro Company is not liable for indirect, incidental or consequential damages in connection with the use of the Toro Products covered by this warranty, including any cost or expense of providing substitute equipment or service during reasonable periods of malfunction or non-use pending completion of repairs under this warranty. Except for the Emissions warranty referenced below, if applicable, there is no other express warranty. All implied warranties of merchantability and fitness for use are limited to the duration of this express warranty.

Some states do not allow exclusions of incidental or consequential damages, or limitations on how long an implied warranty lasts, so the above exclusions and limitations may not apply to you. This warranty gives you specific legal rights, and you may also have other rights which vary from state to state.

Note Regarding Emissions Warranty

The Emissions Control System on your Product may be covered by a separate warranty meeting requirements established by the U.S. Environmental Protection Agency (EPA) and/or the California Air Resources Board (CARB). The hour limitations set forth above do not apply to the Emissions Control System Warranty. Refer to the Engine Emission Control Warranty Statement supplied with your product or contained in the engine manufacturer's documentation.

California Proposition 65 Warning Information

What is this warning?

You may see a product for sale that has a warning label like the following:



WARNING: Cancer and Reproductive Harm—www.p65Warnings.ca.gov.

What is Prop 65?

Prop 65 applies to any company operating in California, selling products in California, or manufacturing products that may be sold in or brought into California. It mandates that the Governor of California maintain and publish a list of chemicals known to cause cancer, birth defects, and/or other reproductive harm. The list, which is updated annually, includes hundreds of chemicals found in many everyday items. The purpose of Prop 65 is to inform the public about exposure to these chemicals.

Prop 65 does not ban the sale of products containing these chemicals but instead requires warnings on any product, product packaging, or literature with the product. Moreover, a Prop 65 warning does not mean that a product is in violation of any product safety standards or requirements. In fact, the California government has clarified that a Prop 65 warning "is not the same as a regulatory decision that a product is 'safe' or 'unsafe.'" Many of these chemicals have been used in everyday products for years without documented harm. For more information, go to <https://oag.ca.gov/prop65/faqs-view-all>.

A Prop 65 warning means that a company has either (1) evaluated the exposure and has concluded that it exceeds the "no significant risk level"; or (2) has chosen to provide a warning based on its understanding about the presence of a listed chemical without attempting to evaluate the exposure.

Does this law apply everywhere?

Prop 65 warnings are required under California law only. These warnings are seen throughout California in a wide range of settings, including but not limited to restaurants, grocery stores, hotels, schools, and hospitals, and on a wide variety of products. Additionally, some online and mail order retailers provide Prop 65 warnings on their websites or in catalogs.

How do the California warnings compare to federal limits?

Prop 65 standards are often more stringent than federal and international standards. There are various substances that require a Prop 65 warning at levels that are far lower than federal action limits. For example, the Prop 65 standard for warnings for lead is 0.5 µg/day, which is well below the federal and international standards.

Why don't all similar products carry the warning?

- Products sold in California require Prop 65 labelling while similar products sold elsewhere do not.
- A company involved in a Prop 65 lawsuit reaching a settlement may be required to use Prop 65 warnings for its products, but other companies making similar products may have no such requirement.
- The enforcement of Prop 65 is inconsistent.
- Companies may elect not to provide warnings because they conclude that they are not required to do so under Prop 65; a lack of warnings for a product does not mean that the product is free of listed chemicals at similar levels.

Why does Toro include this warning?

Toro has chosen to provide consumers with as much information as possible so that they can make informed decisions about the products they buy and use. Toro provides warnings in certain cases based on its knowledge of the presence of one or more listed chemicals without evaluating the level of exposure, as not all the listed chemicals provide exposure limit requirements. While the exposure from Toro products may be negligible or well within the "no significant risk" range, out of an abundance of caution, Toro has elected to provide the Prop 65 warnings. Moreover, if Toro does not provide these warnings, it could be sued by the State of California or by private parties seeking to enforce Prop 65 and subject to substantial penalties.