



Count on it.

Parts Catalog

**Pro Force® Debris Blower
Groundsmaster® 3200 or 3300 Series
Traction Unit**

Model No. 31916—Serial No. 40000000 and Up



Ordering Replacement Parts

To order replacement parts, please supply the part number, the quantity, and the description of each part desired.

Understanding Reference Numbers

Each identified part in an illustration has a reference number. The reference number for a part also appears in the parts list, along with other information about the part.

This catalog uses two special reference number formats, one to indicate parts in a service assembly and another to indicate the quantity of a given part in an illustration.

Service Assembly Reference Numbers

Parts in service assemblies have reference numbers in the form a:b. The a represents the reference number of the entire service assembly and the b represents a sequential number unique to each part within the service assembly.

For example, a wheel assembly might be identified by reference number 6, the tire by 6:1, the valve by 6:2, and the wheel by 6:3. When you order the assembly identified by reference number 6, you receive all parts identified by reference numbers 6:1, 6:2, and 6:3. However, you may also order any part individually. Reference numbers of this type appear in illustration and in parts lists.

Reference Numbers Indicating Quantity

In an illustration, if a reference number indicates more than one part, the reference number has the form nX y. The n represents the quantity of the part, the X is the multiplication symbol, and the y represents the reference number.

For example, in an illustration, the reference number 2X 37 means that two of the parts identified by reference number 37 are indicated.

Contents

Frame Assembly.....	4
Wheel Assembly No. 93-9938.....	5
Nozzle Assembly.....	6
Turbine Mounting Assembly.....	7
Turbine Assembly No. 127-6277.....	8
Hydraulic Assembly.....	9
GM32X0/33X0 Variant Assembly.....	10
Drive Shaft Assembly No. 121-5322.....	11
Guide Whip Assembly.....	12

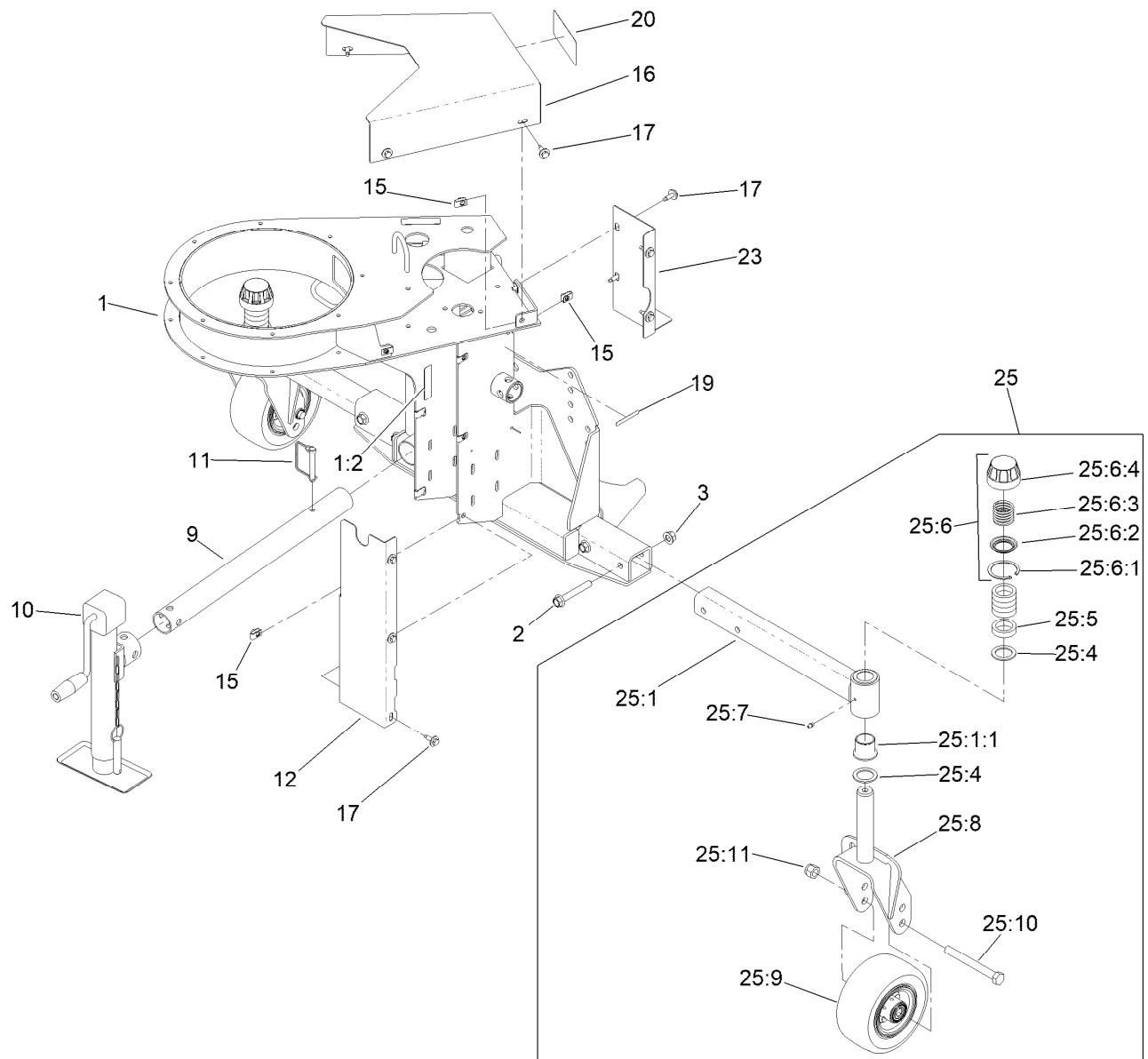

Frame Assembly

Ref.	Part Number	Qty.	Description	Ref.	Part Number	Qty.	Description
1	144-3566	1	Blower Frame Service ASM	25:1	144-3520-03	1	Tube-Caster Hub [black]
1:2	119-0217	3	Decal-Danger	25:1:1	69-6470	2	Bushing-Caster
2	126-3900	4	Screw-HHF	25:4	69-6860	2	Washer-Thrust
3	139-1689	4	Nut-HF	25:5	69-1510	5	Spacer
9	125-4221-03	1	Tube-Stand	25:6	92-8862	1	HOC Cap ASM
10	T0000-3423	1	Jack-Sidewind	25:6:1	92-5581	1	Ring-Rtng, Snap, Int, Flat
11	107-7400	1	Pin-Lynch	25:6:2	92-5583	1	Washer-Cap
12	139-2129-03	1	Cover-Gear Case	25:6:3	92-5584	1	Spring-Compression
15	115-7721	14	Nut-Clip, U	25:6:4	92-8861	1	Cap-HOC
16	121-9987-03	1	Cover-Belt	25:7	302-5	1	Fitting-Grease
17	114-8418	14	Screw-HWH, Sems	25:8	104-0762-01	1	Fork-Caster
19	133-8061	1	Decal-Warning	25:9	93-9938	1	Wheel ASM
20	144-3323	1	Decal-Service, Driveline	25:10	327-24	1	Screw-HH
23	139-2126-03	1	Cover-Case, Upper	25:11	3296-53	1	Nut-Lock, NI
25	144-3579	2	Castor Arm ASM				

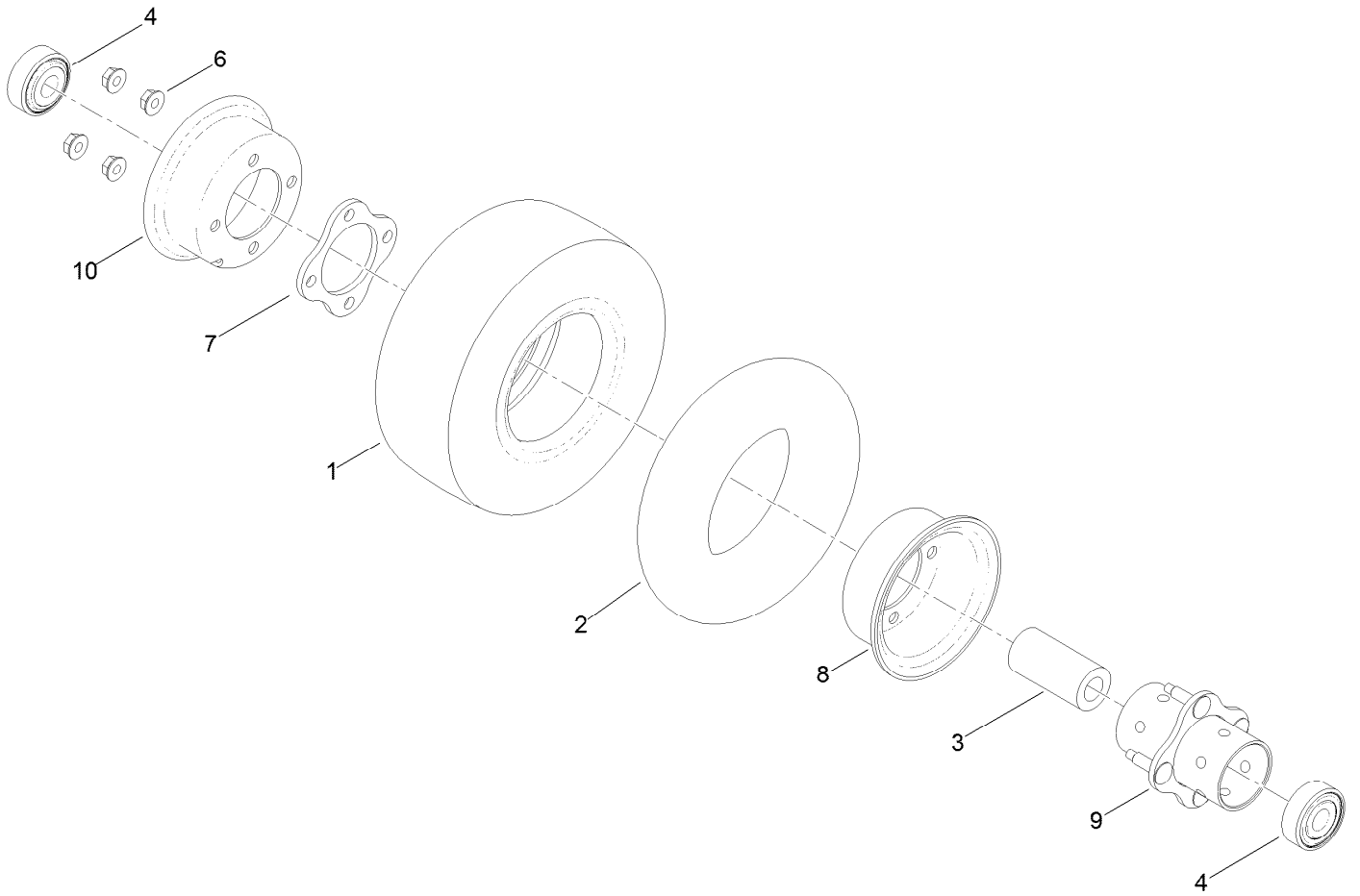

Wheel Assembly No. 93-9938

<i>Ref.</i>	<i>Part Number</i>	<i>Qty.</i>	<i>Description</i>
1	93-9939	1	Tire
2	68-8950	1	Tube-Inner (W/Valve) ●
3	93-4241	1	Spacer-Bearing, Inner
4	120-3366	2	Bearing
6	32128-16	4	Nut-HHF
7	93-4242	1	Plate
8	93-4239	1	Rim-Wheel, Half
9	93-5980	1	Hub
10	95-2741	1	Rim-Wheel, Half

● Not illustrated

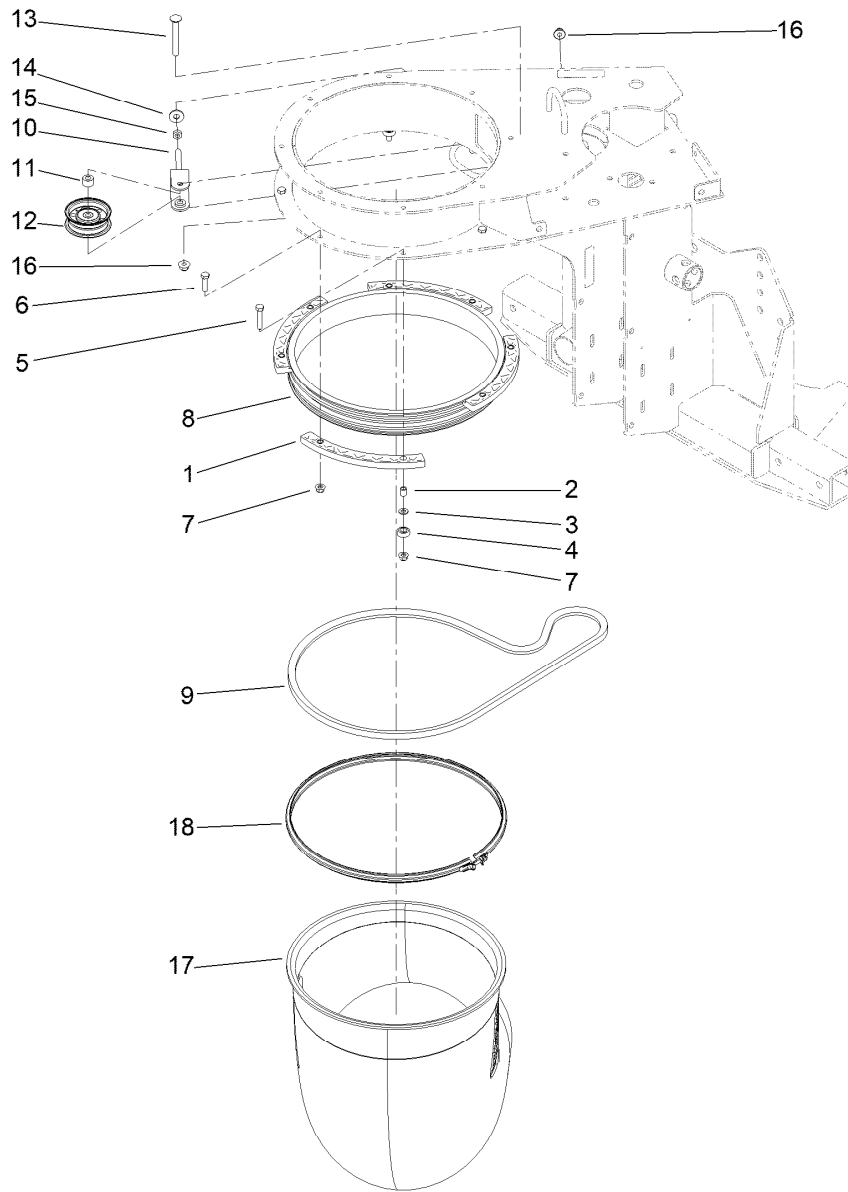

Nozzle Assembly

<i>Ref.</i>	<i>Part Number</i>	<i>Qty.</i>	<i>Description</i>	<i>Ref.</i>	<i>Part Number</i>	<i>Qty.</i>	<i>Description</i>
1	114-9868	4	Guide-Nozzle	10	139-2143	1	Idler Bracket
2	93-6859	8	Spacer	11	125-4264	1	Spacer-Pulley
3	3256-74	4	Washer-Flat	12	130-8362	1	Pulley-Idler, Flat
4	251-259	4	Bearing-Ball	13	109-6868	1	Bolt-Carriage
5	322-8	4	Screw-HH	14	80-6990	1	Washer-Hardened
6	322-6	4	Screw-HH	15	3217-7	1	Nut-Hex
7	104-8300	8	Nut-HF, NI	16	104-8301	2	Nut-HF, NI
8	112-1874	1	Pulley-Nozzle	17	125-4279	1	Nozzle
9	57-4740	1	V-Belt	18	112-6899	1	Clamp-Nozzle

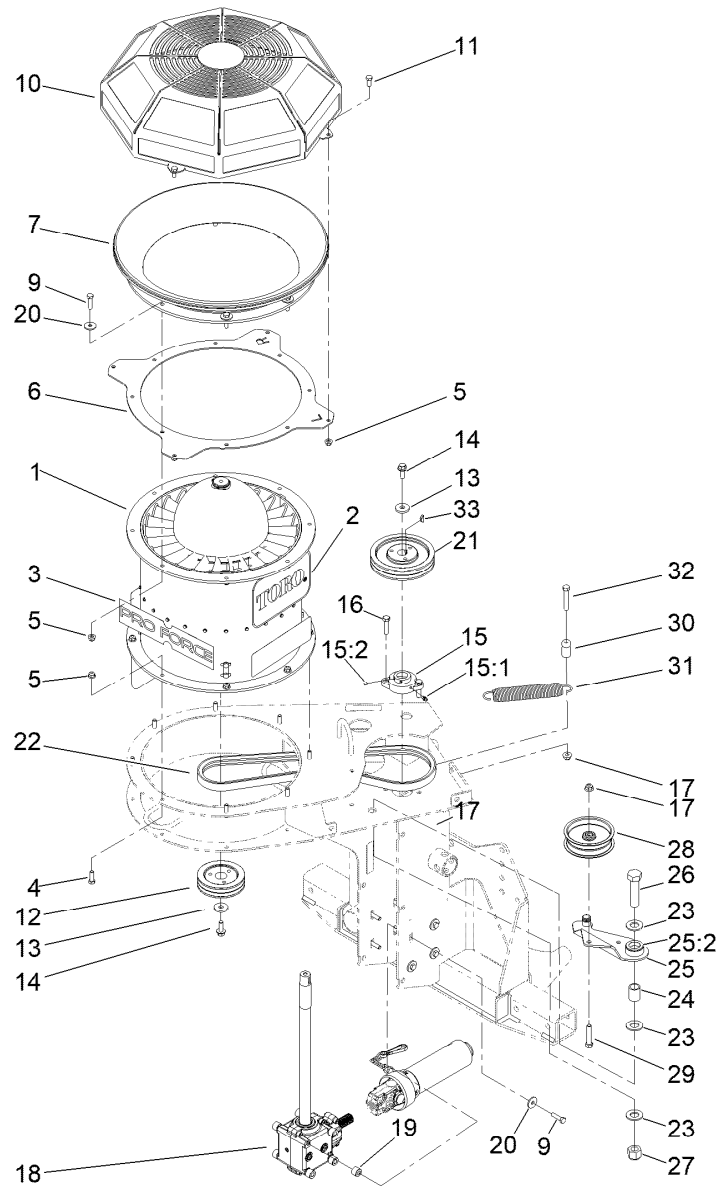

Turbine Mounting Assembly

Ref.	Part Number	Qty.	Description	Ref.	Part Number	Qty.	Description
1	127-6277	1	Turbine ASM	18	144-3204	1	Gearbox ASM
2	62-7400	2	Decal-Toro Logo	19	121-9992	8	Spacer-Gearbox
3	115-5102	1	Decal	20	115-7109	16	Washer-Flat
4	322-5	8	Screw-HH	21	144-3243	1	Pulley-Drive
5	104-8300	20	Nut-HF, NI	22	121-9924	1	Belt-Drive
6	127-6302-03	1	Bracket-Fan	23	92-5836	3	Washer
7	117-8329	1	Bell-Inlet	24	125-4276	1	Spacer-Idler
9	322-6	16	Screw-HH	25	139-2146	1	Idler Arm ASM
10	127-6329-03	1	Guard-Fan	25:2	98-2197	2	Bushing-Flange
11	322-3	4	Screw-HH	26	328-4	1	Screw-HH
12	121-9958	1	Pulley-Driven	27	3296-51	1	Nut-Lock, NI
13	99-2098	2	Washer	28	119-7887	1	Pulley-Idler
14	131-2220	2	Screw-HHF	29	323-10	1	Screw-HH
15	107-7851	1	Bearing-Flange, 2 Bolt	30	125-4275	1	Post-Spring
15:1	302-5	1	Fitting-Grease	31	103-6532	1	Spring-Extension
15:2	3245-35	2	Screw-Set, HSH	32	323-11	1	Screw-HH
16	323-8	2	Screw-HH	33	3257-5	1	Key-Woodruff
17	104-8301	4	Nut-HF, NI				

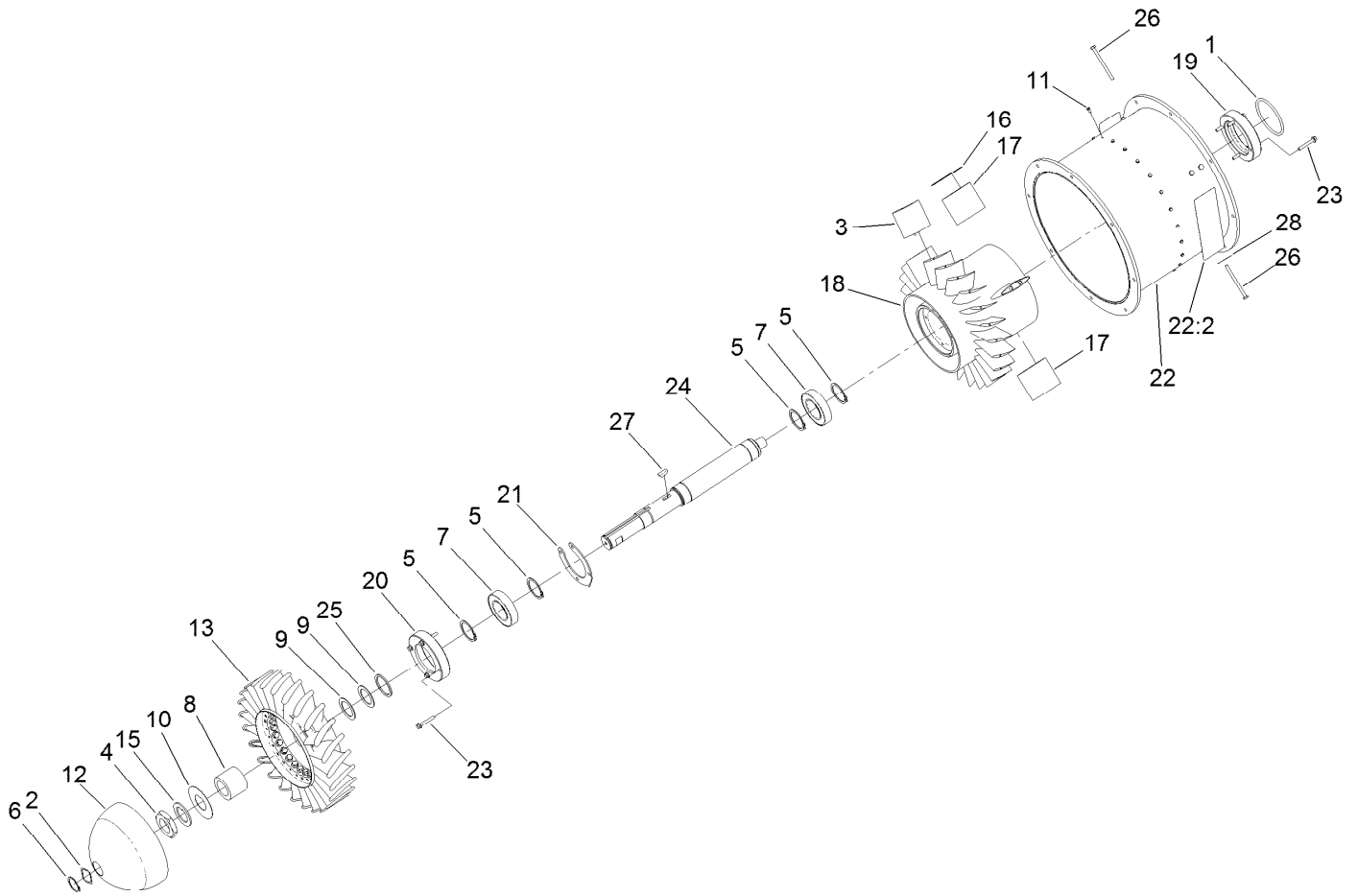

Turbine Assembly No. 127-6277

<i>Ref.</i>	<i>Part Number</i>	<i>Qty.</i>	<i>Description</i>	<i>Ref.</i>	<i>Part Number</i>	<i>Qty.</i>	<i>Description</i>
1	92-9533	1	O-Ring	16	119-6207	2	Spacer-Fin
2	93-4632	1	Washer-Wavey	17	119-6444	4	Mount-Fin
3	112-1871	24	Vane-Stator	18	120-5920	1	Inner Housing
4	112-1899	1	Nut	19	120-6042	1	End-Oring
5	112-1951	4	Ring-Snap, EXT	20	120-6061	1	Bearing-Cap
6	112-1952	1	Ring-Snap, EXT	21	120-6063	1	End-Cap
7	127-6348	2	Bearing-Ball	22	125-4284	1	Vertical Housing ASM
8	114-2164	1	Spacer	22:2	137-3999	2	Decal-Danger
9	115-5131	2	Washer	23	125-4287	8	Screw-HHF
10	115-9005	1	Washer-Tab	24	127-6278	1	Shaft-Fan
11	117-8303	24	Screw-HWH	25	127-6298	1	Spacer-Bearing
12	131-9440	1	Cap-Front	26	321-19	8	Screw-HH
13	117-8356	1	Rotor	27	3257-42	1	Key-Woodruff
15	119-6202	1	Washer-Tab	28	140-6815	4	Tab-Locking

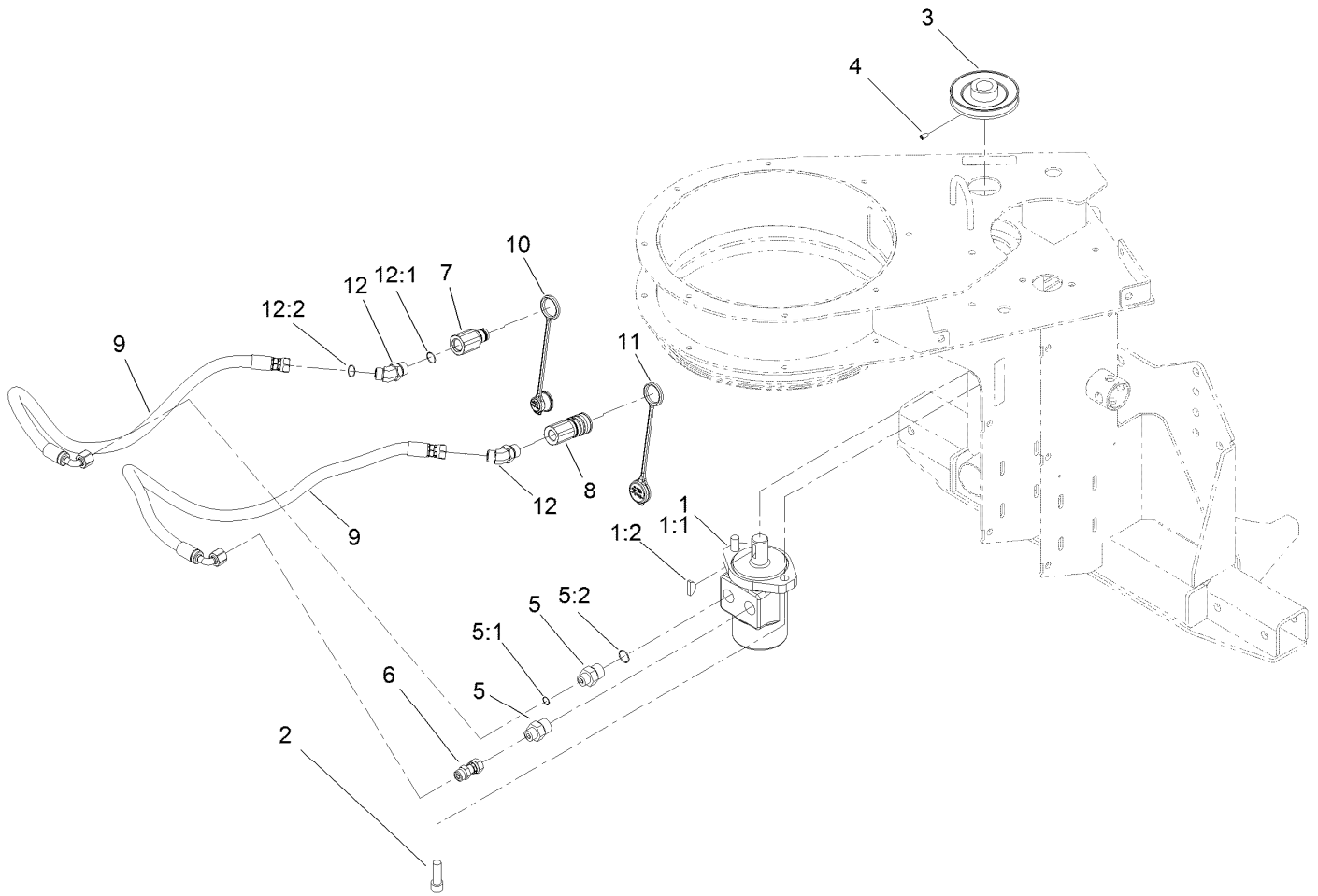

Hydraulic Assembly

<i>Ref.</i>	<i>Part Number</i>	<i>Qty.</i>	<i>Description</i>	<i>Ref.</i>	<i>Part Number</i>	<i>Qty.</i>	<i>Description</i>
1	99-0156	1	HYD Motor ASM	6	125-4278	1	Fitting
1:1	100-1446	1	Seal Kit ●	7	131-6057	1	Fitting-Quick Coupling
1:2	3257-8	1	Key-Woodruff	8	131-6058	1	Fitting-Quick Coupling
2	3274-4	2	Screw-HSH	9	140-6759	2	HYD-Hose
3	125-4281	1	Pulley-Drive	10	131-6069	1	Cap-Dust, Nipple
4	3245-9	2	Screw-Set, HSH	11	131-6070	1	Cap-Dust, Coupler
5	340-141	2	Fitting-STR	12	340-138	2	Fitting-HYD, 45 DEG
5:1	237-22	1	O-Ring	12:1	237-79	1	O-Ring
5:2	237-80	1	O-Ring	12:2	237-22	1	O-Ring

● Not illustrated

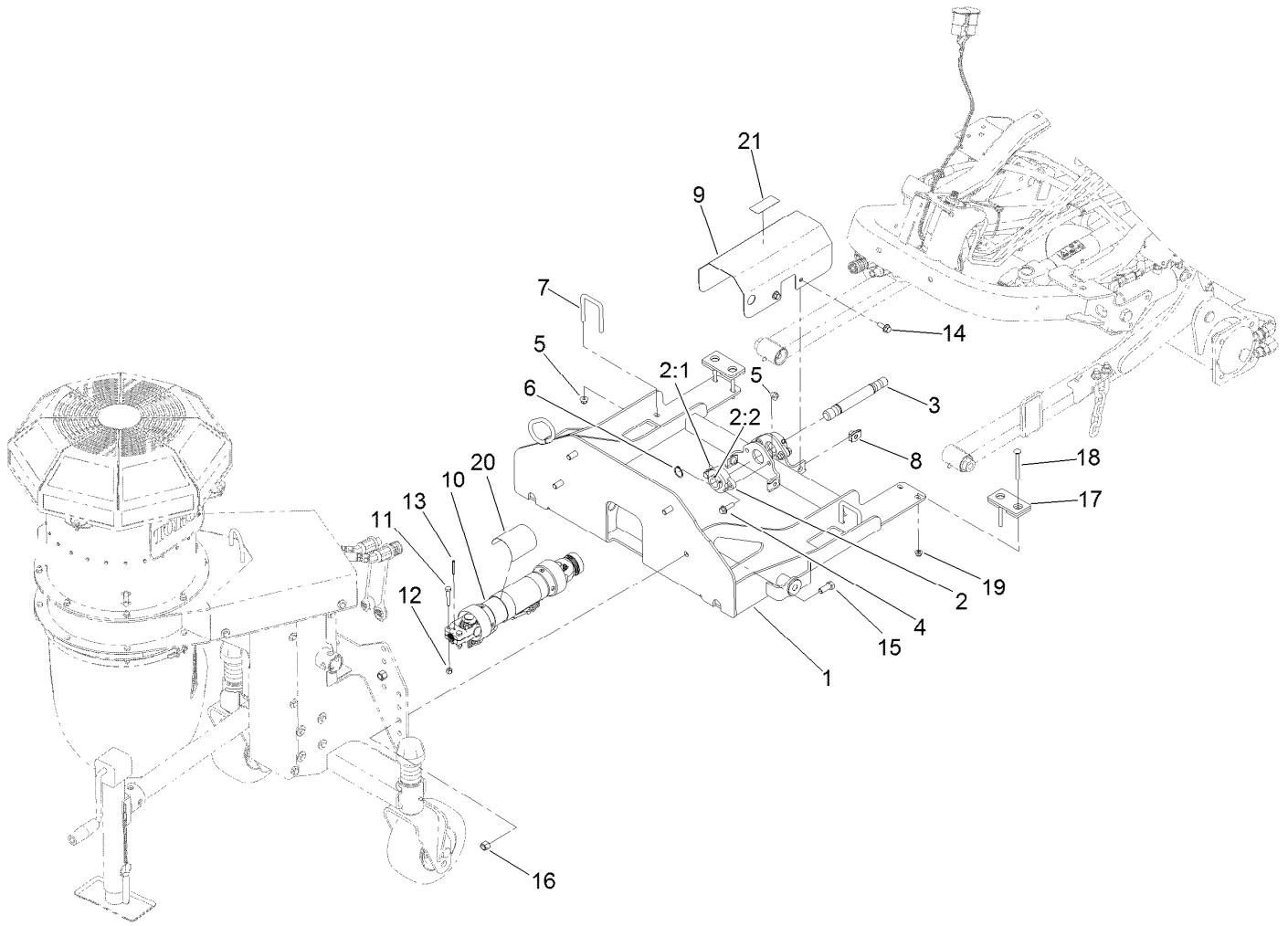

GM32X0/33X0 Variant Assembly

Ref.	Part Number	Qty.	Description	Ref.	Part Number	Qty.	Description
1	140-6680-03	1	Mount-Blower [black]	12	3296-29	2	Nut-Lock, NI
2	107-7851	2	Bearing-Flange, 2 Bolt	13	32121-34	1	Pin-Roll
2:1	302-5	1	Fitting-Grease	14	3234-42	4	Screw-HHF
2:2	3245-35	2	Screw-Set, HSH	15	325-5	4	Screw-HH
3	140-6679	1	Shaft-Jack, PTO	16	3296-23	4	Nut-Lock, NI
4	3234-24	4	Screw-HHF	17	144-3635	2	Plate-Stop
5	104-8301	8	Nut-HF, NI	18	138-0741	4	Screw-CARR
6	32151-29	2	Ring-Retaining	19	104-8300	4	Nut-HF, NI
7	104-9082	2	U-Bolt	20	144-3294	1	Decal - Danger, Entanglement
8	105-4886	4	Nut-Tinnerman	21	139-6304	1	Decal-Danger, Entanglement
9	140-6681-03	1	Cover-PTO				
10	121-5322	1	Drive Shaft				
11	322-9	2	Screw-HH				

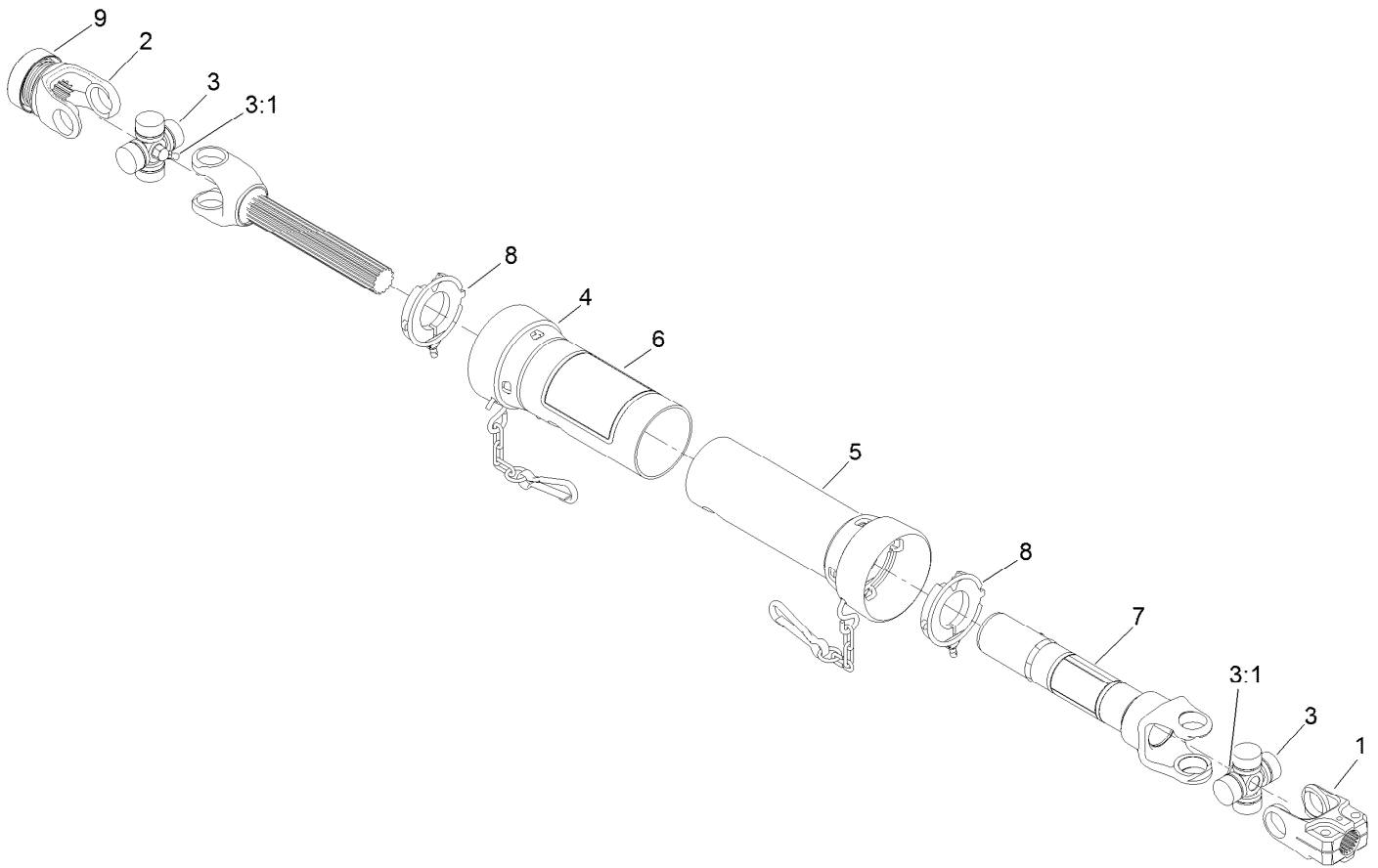

Drive Shaft Assembly No. 121-5322

<i>Ref.</i>	<i>Part Number</i>	<i>Qty.</i>	<i>Description</i>
1	54-9040	1	Yoke-End
2	103-9329	1	Yoke-Quick Disconnect
3	112-1687	2	Cross And Bearing Kit
3:1	62-3820	1	Fitting-Grease
4	125-4294	1	Outer Guard ASM (W/Decal)
5	125-4295	1	Inner Guard ASM
6	92-1581	1	Decal-Safety
7	92-1582	1	Decal-Safety
8	125-4296	2	Guard Repair Kit
9	125-4297	1	Spring-Lock Repair Kit

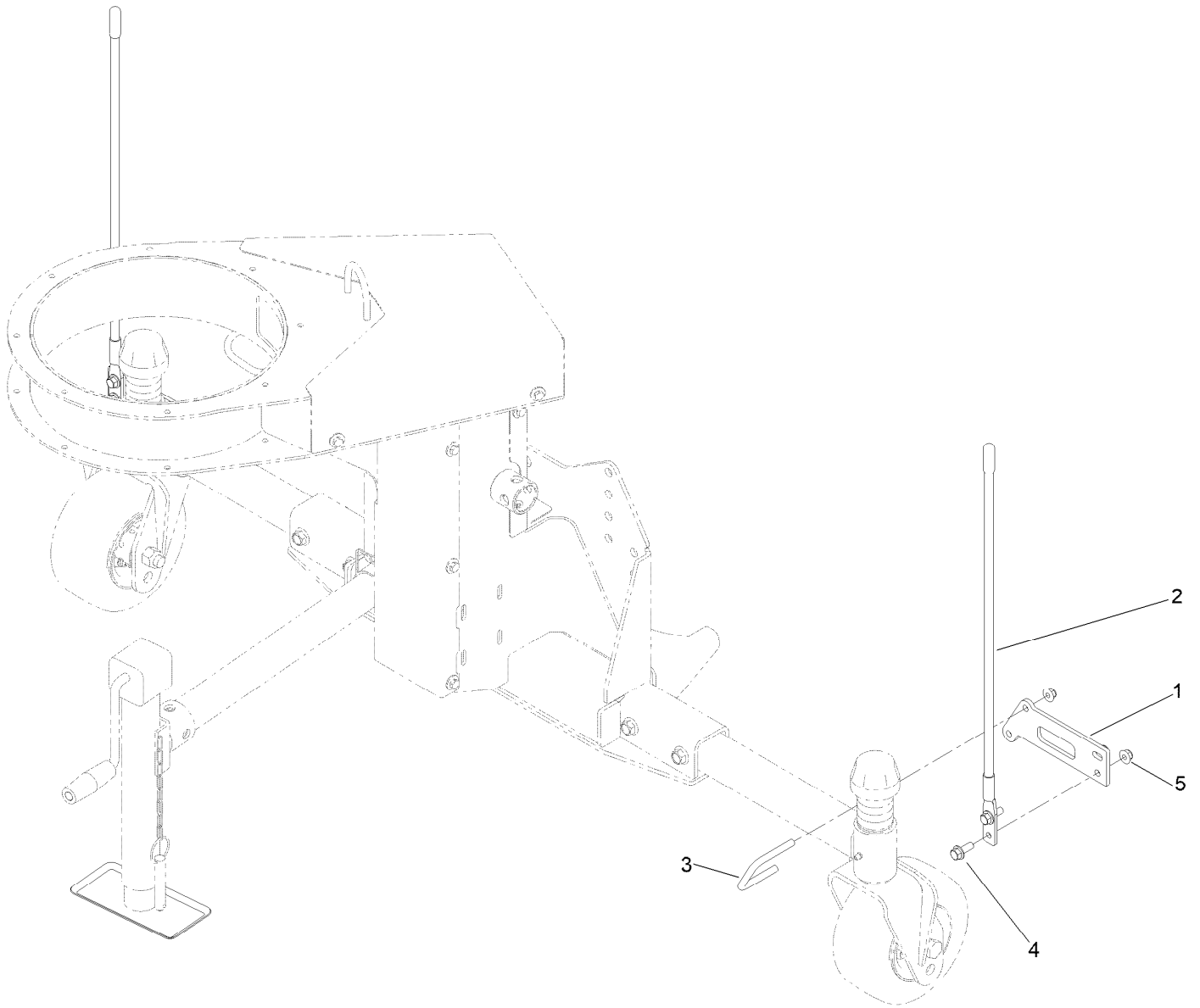

Guide Whip Assembly

Ref.	Part Number	Qty.	Description
1	144-3591	2	Bracket-Guide Whip
2	BAX00005	2	Blade Guide(1)**kit MSC01870**
3	103-2469	2	U-Bolt
4	3234-42	4	Screw-HHF
5	104-8301	8	Nut-HF, NI

Notes:

Notes:

Notes:



Count on it.