



Count on it.

Operator's Manual

Titan® 48in, 54in, and 60in Riding Mower

Model No. 75304—Serial No. 410000000 and Up

Model No. 75305—Serial No. 410000000 and Up

Model No. 75306—Serial No. 400000000 and Up

Model No. 75314—Serial No. 410000000 and Up

Model No. 75315—Serial No. 410000000 and Up

Model No. 75316—Serial No. 400000000 and Up



information and **Note** emphasizes general information worthy of special attention.

The safety-alert symbol (**Figure 2**) appears both in this manual and on the machine to identify important safety messages that you must follow to avoid accidents. This symbol will appear with the word **Danger**, **Warning**, or **Caution**.

- **Danger** indicates an imminently hazardous situation which, if not avoided, **will** result in death or serious injury.
- **Warning** indicates a potentially hazardous situation which, if not avoided, **could** result in death or serious injury.
- **Caution** indicates a potentially hazardous situation which, if not avoided, **may** result in minor or moderate injury.



Figure 2

sa-black

1. Safety-alert symbol

Contents

Safety	4
General Safety	4
Slope Indicator	5
Safety and Instructional Decals	6
Product Overview	12
Controls	13
Specifications	14
Before Operation	14
Before Operation Safety	14
Adding Fuel	15
Performing Daily Maintenance	16
Breaking in a New Machine	16
Using the Safety-Interlock System	16
Positioning the Seat	17
Adjusting the MyRide™ Suspension System	17
Adjusting the Motion-Control Levers	18
During Operation	19
During Operation Safety	19
Operating the Parking Brake	21
Engaging the Blade-Control Switch (PTO)	21
Disengaging the Blade-Control Switch (PTO)	21
Operating the Throttle	22
Operating the Choke	22
Operating the Key Switch	22
Starting the Engine	23
Shutting Off the Engine	23
Using the Motion-Control Levers	23
Driving the Machine	24
Using the Side Discharge	25
Adjusting the Height of Cut	25
Adjusting the Anti-Scalp Rollers	26
Operating Tips	26
After Operation	27
After Operation Safety	27
Cleaning the Machine	27
Pushing the Machine by Hand	27
Transporting the Machine	28
Maintenance	30
Maintenance Safety	30
Recommended Maintenance Schedule(s)	31
Engine Maintenance	32
Engine Safety	32
Servicing the Air Cleaner	32
Servicing the Engine Oil	33
Servicing the Spark Plug	35
Cleaning the Blower Housing	36
Fuel System Maintenance	36
Replacing the In-Line Fuel Filter	36
Electrical System Maintenance	37
Electrical System Safety	37
Servicing the Battery	37
Servicing the Fuses	39
Drive System Maintenance	39

Safety

This machine has been designed in accordance with ANSI standard B71.1-2017.

General Safety

This product is capable of amputating hands and feet and of throwing objects. Always follow all safety instructions to avoid serious personal injury or death.

- Read and understand the contents of this *Operator's Manual* before starting the engine.
- Keep bystanders and children away.
- Do not allow children or untrained people to operate or service the machine. Allow only people who are responsible, trained, familiar with the instructions, and physically capable to operate or service the machine.
- Do not operate the machine near drop-offs, ditches, embankments, water, or other hazards, or on slopes greater than 15°.
- Do not put your hands or feet near moving components of the machine.
- Do not operate the machine without all guards, safety switches, and other safety protective devices in place and functioning properly.
- Shut off the engine, remove the key, and wait for all moving parts to stop before leaving the operator's position. Allow the machine to cool before servicing, adjusting, fueling, cleaning, or storing it.

Checking the Tire Pressure.....	39
Belt Maintenance	40
Inspecting the Belts	40
Replacing the Mower Belt	40
Mower Maintenance.....	41
Blade Safety	41
Servicing the Cutting Blades.....	41
Leveling the Mower Deck.....	44
Removing the Mower Deck.....	46
Installing the Mower Deck.....	47
Replacing the Grass Deflector	47
Cleaning	48
Disposing of Waste	48
Storage	49
Storage Safety.....	49
Cleaning and Storage	49
Storing the Battery	50
Troubleshooting	51
Schematics	53

Slope Indicator

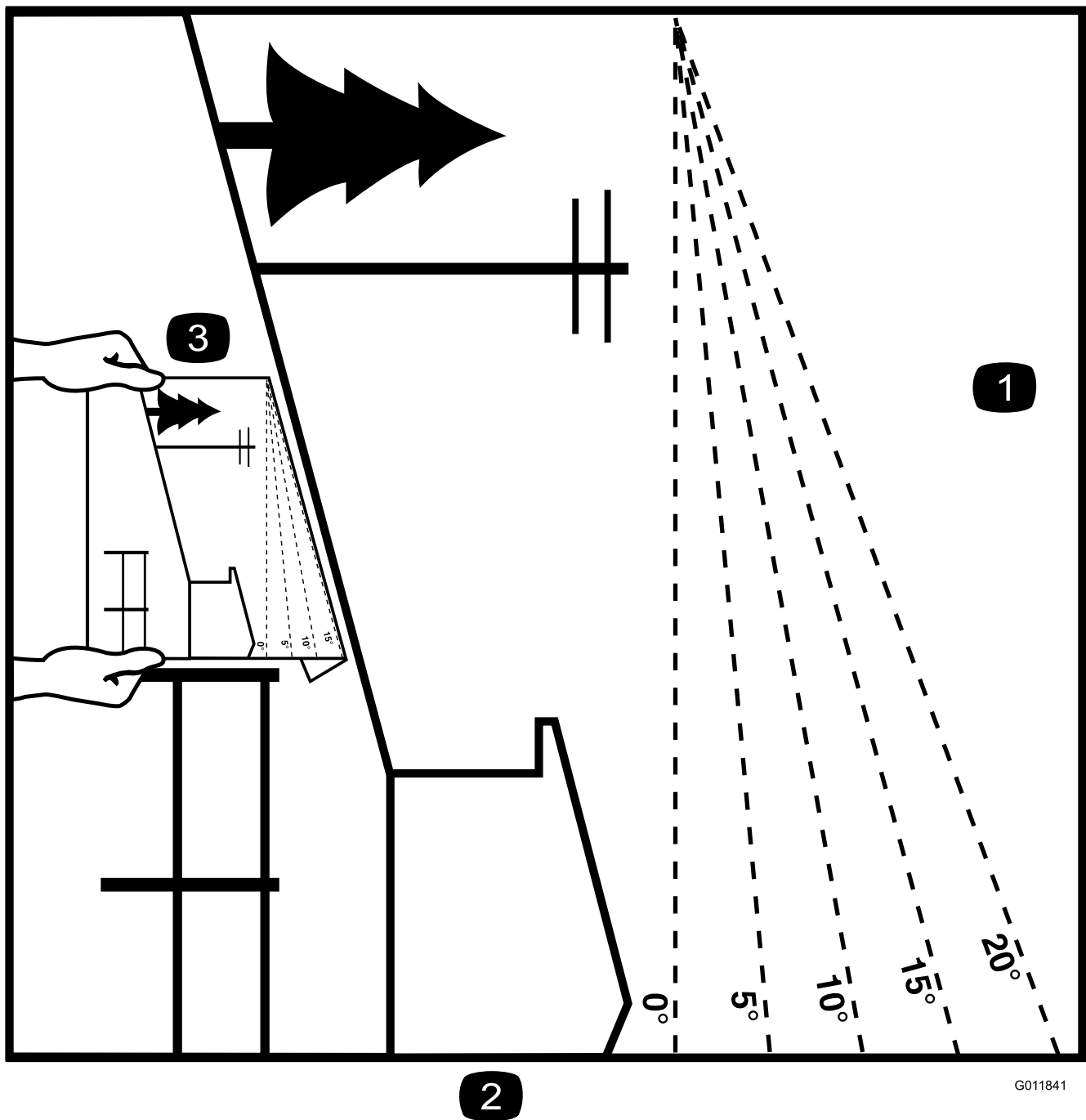

G011841

g011841

2

Figure 3

You may copy this page for personal use.

1. The maximum slope you can operate the machine on is **15 degrees**. Use the slope chart to determine the degree of slope of hills before operating. **Do not operate this machine on a slope greater than 15 degrees**. Fold along the appropriate line to match the recommended slope.
2. Align this edge with a vertical surface, a tree, building, fence pole, etc.
3. Example of how to compare slope with folded edge

Safety and Instructional Decals



Safety decals and instructions are easily visible to the operator and are located near any area of potential danger. Replace any decal that is damaged or missing.

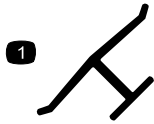

decaloemmarkt

Manufacturer's Mark

1. This mark indicates that the blade is identified as a part from the original machine manufacturer.



decalbatterysymbols

Battery Symbols

Some or all of these symbols are on your battery.

- | | |
|--|---|
| 1. Explosion hazard | 6. Keep bystanders away from the battery. |
| 2. No fire, open flame, or smoking | 7. Wear eye protection; explosive gases can cause blindness and other injuries. |
| 3. Caustic liquid/chemical burn hazard | 8. Battery acid can cause blindness or severe burns. |
| 4. Wear eye protection. | 9. Flush eyes immediately with water and get medical help fast. |
| 5. Read the <i>Operator's Manual</i> . | 10. Contains lead; do not discard |

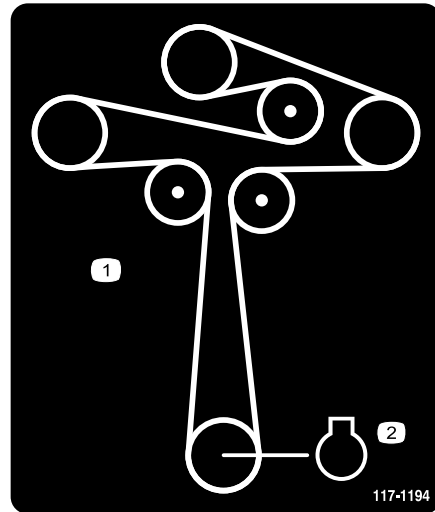

117-1194

decal117-1194

117-1194

1. Belt routing
2. Engine

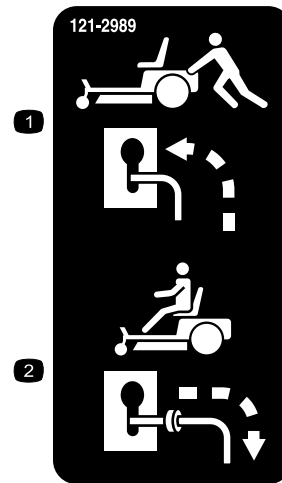

121-2989

decal121-2989b

121-2989

1. Bypass lever position for pushing the machine
2. Bypass lever position for operating the machine



decal130-0731

130-0731

1. Warning—thrown object hazard; keep the deflector shield in place.
2. Cutting hazard of hand or foot, mower blade—keep away from moving parts.

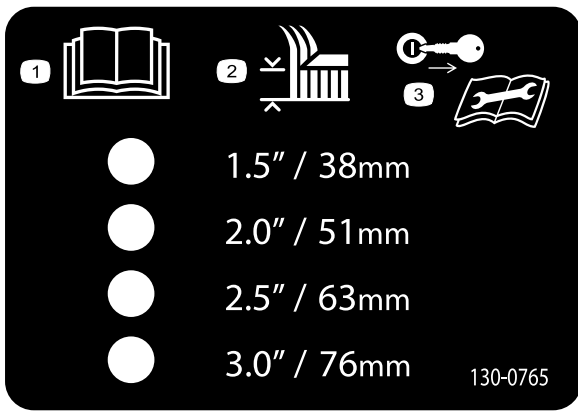

130-0765

decal130-0765

1. Read the *Operator's Manual*.
2. Height-of-cut selection
3. Remove the key before performing maintenance.

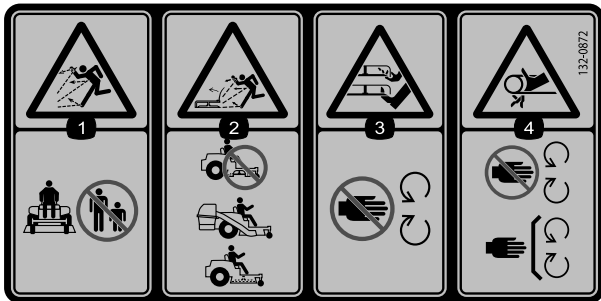

132-0872

decal132-0872

1. Thrown object hazard—keep bystanders away from the machine.
2. Thrown object hazard, raised deflector—do not operate the machine with an open deck; use a bagger or a deflector.
3. Severing hazard of hand or foot—keep away from moving parts.
4. Entanglement hazard—keep away from moving parts; keep all guards and shields in place.



133-8062

decal133-8062

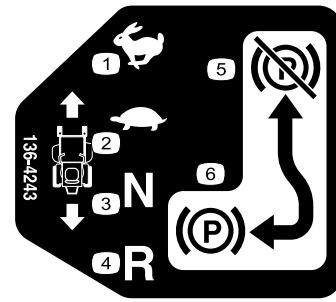

136-4243

decal136-4243

1. Fast
2. Slow
3. Neutral
4. Reverse
5. Parking brake disengaged
6. Parking brake engaged

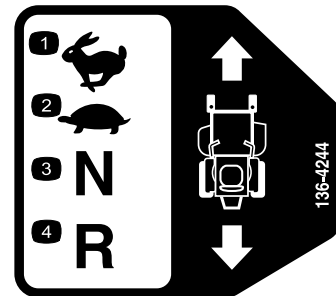

136-4244

decal136-4244

1. Fast
2. Slow
3. Neutral
4. Reverse

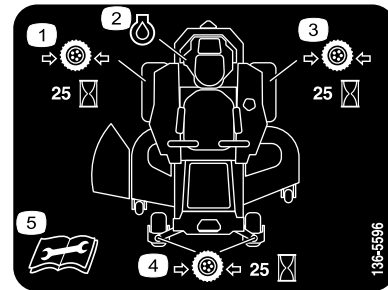

136-5596

decal136-5596

1. Check the tire pressure every 25 operating hours.
2. Engine oil
3. Check the tire pressure every 25 operating hours.
4. Check the tire pressure every 25 operating hours.
5. Read the *Operator's Manual* before performing maintenance.

Decal 138-2456 is molded onto the fuel tank.

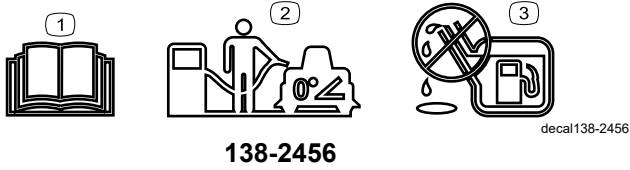

1. Read the *Operator's Manual*.
2. Park the machine on a level surface when filling the fuel tank.
3. Do not overfill the fuel tank.

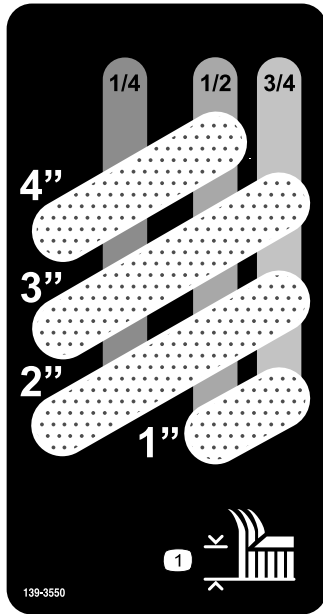

1. Height of cut

Decal 132-0869 is for models with MyRide only.

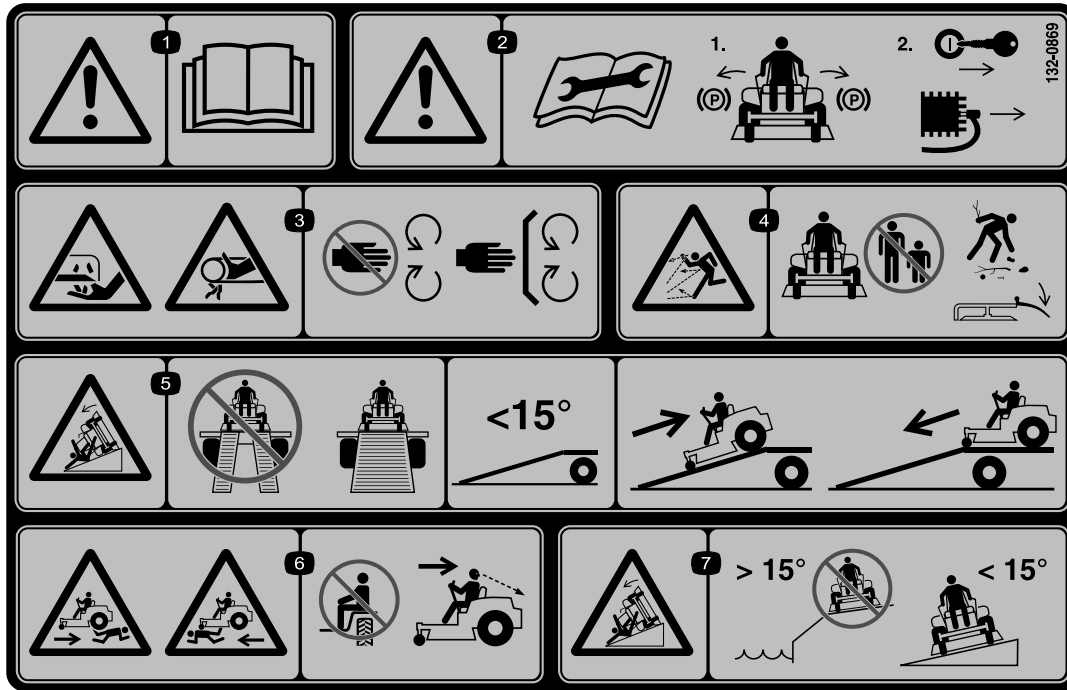

132-0869

decal132-0869

Note: This machine complies with the industry standard stability test in the static lateral and longitudinal tests with the maximum recommended slope indicated on the decal. Review the instructions for operating the machine on slopes in the *Operator's Manual* as well as the conditions in which you would operate the machine to determine whether you can operate the machine in the conditions on that day and at that site. Changes in the terrain can result in a change in slope operation for the machine.

- | | | | |
|--|--|---|---|
| <p>1. Warning—read the <i>Operator's Manual</i>.</p> <p>2. Warning—read the <i>Operator's Manual</i> before performing maintenance; engage the parking brake, remove the key, and disconnect the spark plug.</p> | <p>3. Cutting/dismemberment hazard of the hand, mower blade; entanglement hazard of the hand, belt—stay away from moving parts; keep all guards and shields in place.</p> <p>4. Thrown object hazard—keep bystanders away; pick up debris before operating; keep the deflector in place.</p> | <p>5. Tipping hazard—do not use dual ramps when loading onto a trailer; use 1 ramp wide enough for the machine; use a ramp with a slope less than 15°; back up the ramp when loading the machine and drive forward off the ramp when unloading.</p> <p>6. Runover hazard—do not carry passengers; look behind you when mowing in reverse.</p> | <p>7. Tipping hazard—do not use the machine near drop-offs or on slopes greater than 15°; only operate across slopes less than 15°.</p> |
|--|--|---|---|

Decal 133-5198 is for models with MyRide only.

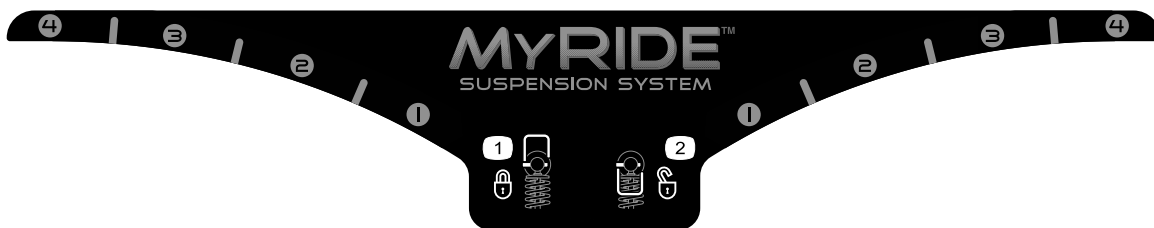

133-5198

decal133-5198

- | | |
|--------------------|----------------------|
| <p>1. Cam lock</p> | <p>2. Cam unlock</p> |
|--------------------|----------------------|

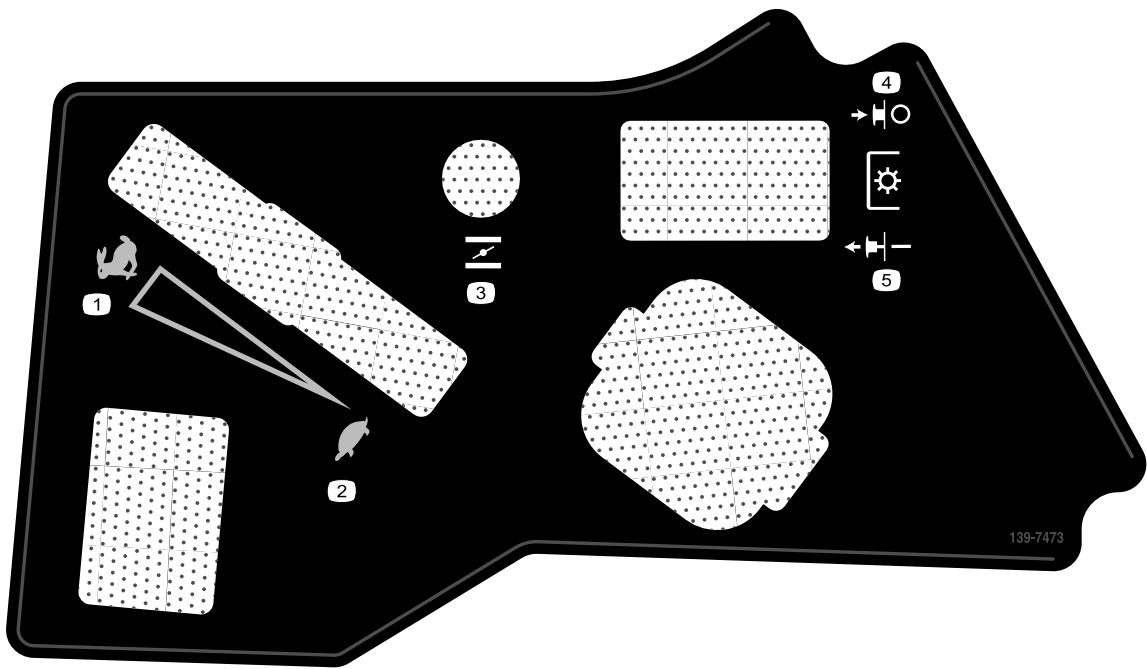

139-7473

decal139-7473

139-7473

- 1. Fast
- 2. Slow
- 3. Choke
- 4. PTO—disengage
- 5. PTO—engage

Decal 140-3451 is for models without MyRide only.

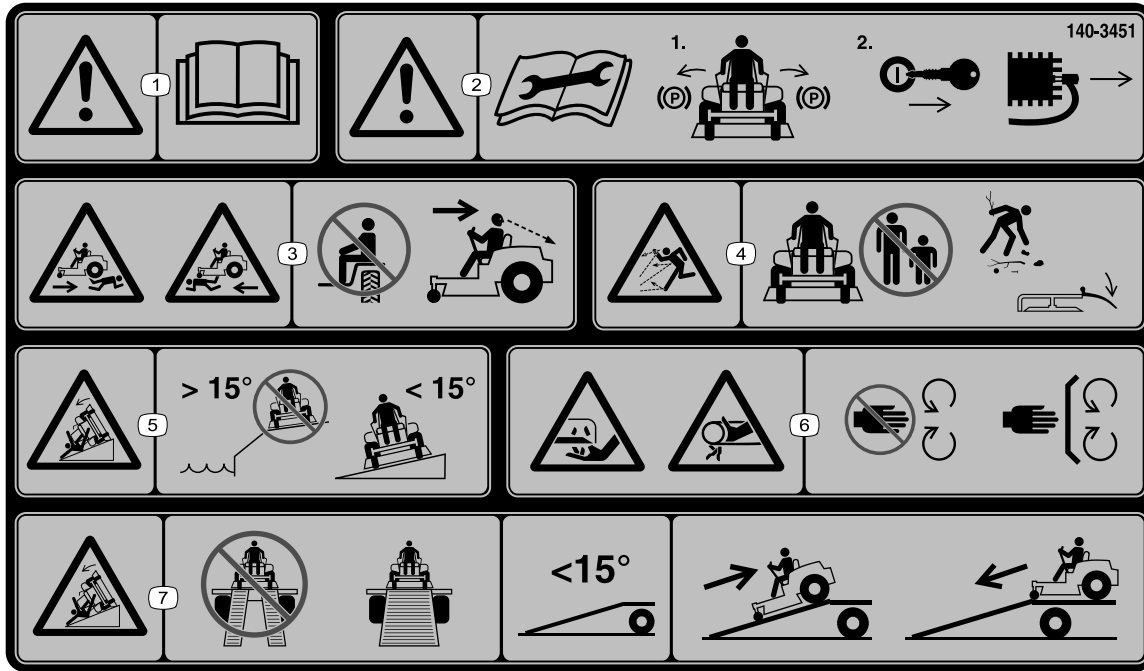

140-3451

decal140-3451

Note: This machine complies with the industry standard stability test in the static lateral and longitudinal tests with the maximum recommended slope indicated on the decal. Review the instructions for operating the machine on slopes in the *Operator's Manual* as well as the conditions in which you would operate the machine to determine whether you can operate the machine in the conditions on that day and at that site. Changes in the terrain can result in a change in slope operation for the machine.

1. Warning—read the *Operator's Manual*.
2. Warning—read the *Operator's Manual* before performing maintenance; move the traction controls to the Park position, remove the key, and disconnect the spark plug wire.
3. Runover hazard—do not carry passengers; look behind you when moving in reverse.
4. Thrown object hazard—keep bystanders away; pick up debris before mowing; keep the deflector in place.
5. Tipping hazard—do not use the machine near drop-offs or on slopes greater than 15°; operate across slopes less than 15°.
6. Cutting dismemberment hazard of hand, mower blade; entanglement hazard of hand, belt—stay away from moving parts; keep all guards and shields in place.
7. Tipping hazard—do not use dual ramps when loading onto a trailer; use 1 ramp wide enough for the machine; use a ramp with a slope less than 15°; back up the ramp (in reverse) and drive forward off the ramp.

Product Overview

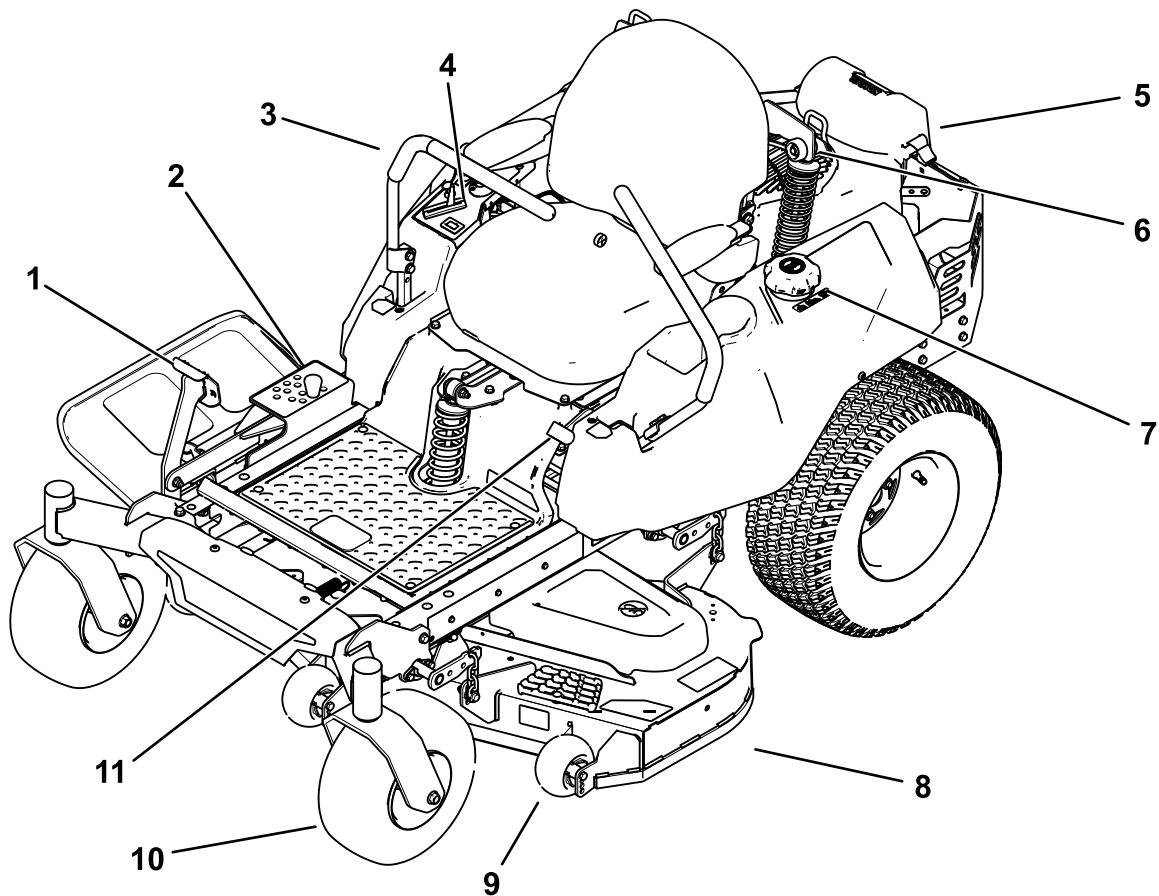

Figure 4

g335095

- | | | |
|-------------------------|---|-------------------------|
| 1. Deck-lift pedal | 5. Engine | 9. Anti-scalp roller |
| 2. Height-of-cut pin | 6. MyRide™ suspension system (MyRide machines only) | 10. Caster wheel |
| 3. Motion-control lever | 7. Fuel cap | 11. Parking-brake lever |
| 4. Controls | 8. Mower deck | |

Controls

Become familiar with all the controls before you start the engine and operate the machine.

Control Panel

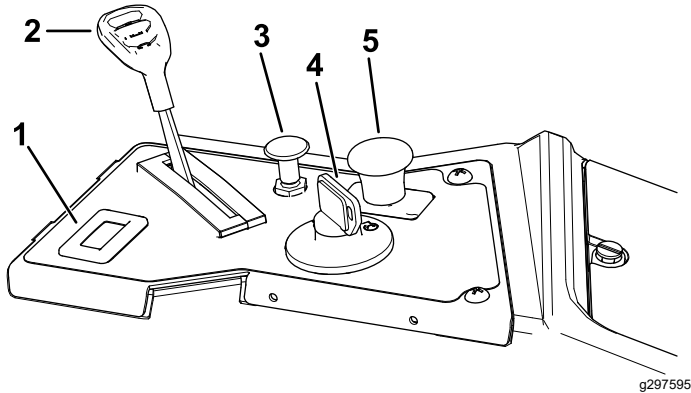

Figure 5

- | | |
|---------------------|---|
| 1. Hour meter | 4. Key switch |
| 2. Throttle control | 5. Blade-control switch (power takeoff) |
| 3. Choke control | |

Fuel Gauge

The fuel gauge displays the amount of fuel in the tank (Figure 6).

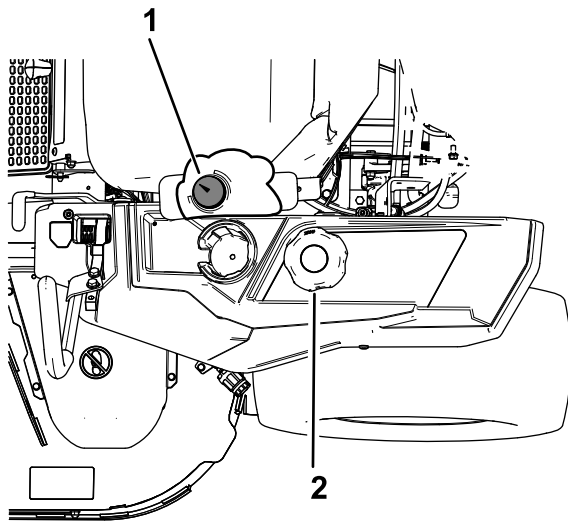

Figure 6

- | | |
|---------------|------------------|
| 1. Fuel gauge | 2. Fuel-tank cap |
|---------------|------------------|

Throttle Control

The throttle controls the engine speed, and it has a continuous-variable setting from the SLOW to FAST position (Figure 5).

Choke Control

Use the choke control to start a cold engine (Figure 5).

Hour Meter

The hour meter records the number of hours the engine has operated. It operates when the engine is running. Use these times for scheduling regular maintenance (Figure 5).

Motion-Control Levers

Use the motion-control levers to drive the machine forward, reverse, and turn either direction (Figure 4).

Neutral-Lock Position

Move the motion-control levers outward from the center to the NEUTRAL-LOCK position when exiting the machine (Figure 24). Always position the motion-control levers into the NEUTRAL-LOCK position when you stop the machine or leave it unattended.

Parking-Brake Lever

The parking-brake lever is located on the left side of the console (Figure 4). The brake lever engages a parking brake on the drive wheels.

To engage the parking brake, pull up the lever until it latches into the detent slot.

To disengage the parking brake, pull the lever out of the detent slot and toward you, then push it down.

Foot Pedal Deck-Lift System

The foot pedal deck-lift system allows you to lower and raise the deck from the seated position. You can use the foot pedal to lift the deck briefly to avoid obstacles (Figure 4).

Key Switch

The key switch, used to start and shut off the engine, has 3 positions: OFF, RUN, and START (Figure 5).

Blade-Control Switch (Power Takeoff)

The blade-control switch, represented by a power-takeoff (PTO) symbol, engages and disengages power to the mower blades (Figure 5).

Height-of-Cut Pin

The height-of-cut pin works with the foot pedal to lock the deck in a specific cutting height. Adjust the height of cut only when the machine is not moving (Figure 4).

Attachments/Accessories

A selection of Toro approved attachments and accessories is available for use with the machine to enhance and expand its capabilities. Contact your Authorized Service Dealer or authorized Toro distributor or go to www.Toro.com for a list of all approved attachments and accessories.

To ensure optimum performance and continued safety certification of the machine, use only genuine Toro replacement parts and accessories. Replacement parts and accessories made by other manufacturers could be dangerous, and such use could void the product warranty.

Specifications

Specifications and design are subject to change without notice.

	48in Mower Deck	54in Mower Deck	60in Mower Deck
Cutting width	122 cm (48 inches)	137 cm (54 inches)	152 cm (60 inches)
Width with deflector down	163 cm (64 inches)	178 cm (70 inches)	193 cm (76 inches)
Width with deflector raised	140 cm (55 inches)	155 cm (61 inches)	170 cm (67 inches)
Length	206 cm (81 inches)	206 cm (81 inches)	206 cm (81 inches)
Height	122 cm (48 inches)	122 cm (48 inches)	122 cm (48 inches)
Weight (non-MyRide models)	337 kg (742 lb)	344 kg (758 lb)	354 kg (780 lb)
Weight (MyRide models)	356 kg (784 lb)	363 kg (800 lb)	371 kg (819 lb)

Operation

Note: Determine the left and right sides of the machine from the normal operating position.

Before Operation

Before Operation Safety

General Safety

- Do not allow children or untrained people to operate or service the machine. Local regulations may restrict the age of the operator. The owner is responsible for training all operators and mechanics.
- Inspect the area where you will use the machine, and remove all objects that could interfere with the operation of the machine or that the machine could throw.
- Become familiar with the safe operation of the equipment, operator controls, and safety signs.
- Check that operator-presence controls, safety switches, and guards are attached and working properly. Do not operate the machine unless they are functioning properly.
- Shut off the engine, remove the key, and wait for all moving parts to stop before leaving the operator's position. Allow the machine to cool before servicing, adjusting, fueling, cleaning, or storing it.
- Before mowing, inspect the machine to ensure that the cutting assemblies are working properly.
- Evaluate the terrain to determine the appropriate equipment and any attachments or accessories required to operate the machine properly and safely.
- Wear appropriate clothing, including eye protection; long pants; substantial, slip-resistant footwear; and hearing protection. Tie back long hair and do not wear loose clothing or loose jewelry.
- Do not carry passengers on the machine.
- Keep bystanders and pets away from the machine during operation. Shut off the machine and attachment(s) if anyone enters the area.
- Do not operate the machine unless all guards and safety devices, such as the deflectors and the entire grass catcher, are in place and functioning properly. Replace worn or deteriorated parts when necessary.

Fuel Safety

- Fuel is extremely flammable and highly explosive. A fire or explosion from fuel can burn you and others and can damage property.
 - To prevent a static charge from igniting the fuel, remove the machine from the truck or trailer and refuel it on the ground, away from all vehicles. If this is not possible, place a portable fuel container on the ground, away from all vehicles, and fill it; then refuel the machine from the fuel container rather than from a fuel-dispenser nozzle.
 - Fill the fuel tank outdoors on level ground, in an open area, and when the engine is cold. Wipe up any fuel that spills.
 - Do not handle fuel when smoking or around an open flame or sparks.
 - Do not remove the fuel cap or add fuel to the tank while the engine is running or hot.
 - If you spill fuel, do not attempt to start the engine. Avoid creating a source of ignition until the fuel vapors have dissipated.
 - Store fuel in an approved container and keep it out of the reach of children.
- Fuel is harmful or fatal if swallowed. Long-term exposure to vapors can cause serious injury and illness.
 - Avoid prolonged breathing of vapors.
 - Keep your hands and face away from the nozzle and the fuel-tank opening.
 - Keep fuel away from your eyes and skin.
- Do not store the machine or fuel container where there is an open flame, spark, or pilot light, such as on a water heater or on other appliances.
- Do not operate the machine without the entire exhaust system in place and in proper working condition.
- Keep the fuel-dispenser nozzle in contact with the rim of the fuel tank or container opening at all times until fueling is complete. Do not use a nozzle lock-open device.
- If you spill fuel on your clothing, change your clothing immediately.
- Do not overfill the fuel tank. Replace the fuel cap and tighten it securely.
- Clean grass and debris from the cutting unit, muffler, drives, grass catcher, and engine compartment to help prevent fires. Clean up oil or fuel spills.

Adding Fuel

Recommended Fuel

Type	Unleaded gasoline
Minimum octane rating	87 (US) or 91 (research octane; outside the US)
Ethanol	No more than 10% by volume
Methanol	None
MTBE (methyl tertiary butyl ether)	Less than 15% by volume
Oil	Do not add to the fuel

Use only clean, fresh (no more than 30 days old), fuel from a reputable source.

Using Stabilizer/Conditioner

Use fuel stabilizer/conditioner in the machine to keep the fuel fresh longer when used as directed by the fuel-stabilizer manufacturer.

Important: Do not use fuel additives containing methanol or ethanol.

Add the amount of fuel stabilizer/conditioner to fresh fuel as directed by the fuel-stabilizer manufacturer.

Filling the Fuel Tank

1. Park the machine on a level surface.
2. Engage the parking brake.
3. Shut off the engine and remove the key.
4. Clean around the fuel-tank cap.
5. Fill the fuel tank until the fuel gauge reads at the full mark (Figure 7). Do not fill the fuel tank completely full.

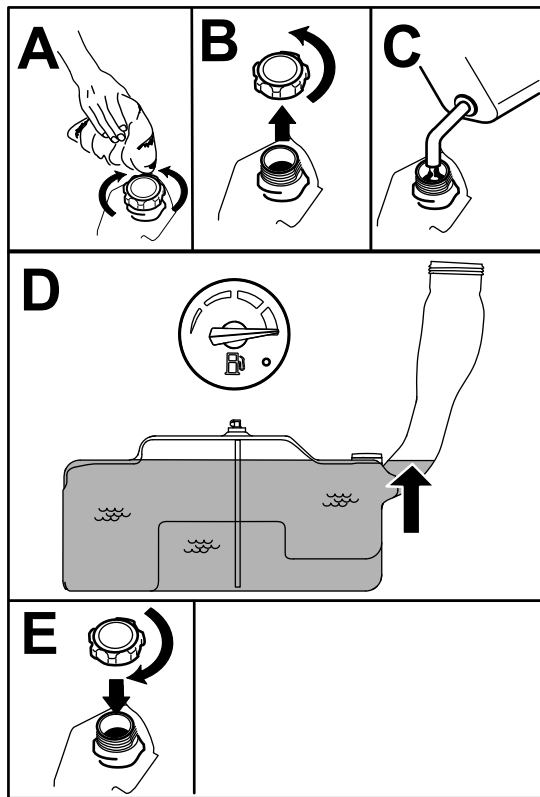

Figure 7

g197123

Performing Daily Maintenance

Before starting the machine each day, perform the Each Use/Daily procedures listed in [Maintenance \(page 30\)](#).

Breaking in a New Machine

New engines take time to develop full power. Mower decks and drive systems have higher friction when new, placing additional load on the engine. Allow 40 to 50 hours of break-in time for new machines to develop full power and best performance.

Using the Safety-Interlock System

⚠ WARNING

If the safety-interlock switches are disconnected or damaged, the machine could operate unexpectedly, causing personal injury.

- Do not tamper with the interlock switches.
- Check the operation of the interlock switches daily and replace any damaged switches before operating the machine.

Understanding the Safety-Interlock System

The safety-interlock system is designed to prevent the engine from starting unless:

- The blade-control switch (PTO) is disengaged.
- The motion-control levers are in the NEUTRAL-LOCK position.
- The parking brake is engaged.

The safety-interlock system also is designed to shut off the engine whenever the control levers are out of the NEUTRAL-LOCK position and you rise from the seat.

Testing the Safety-Interlock System

Service Interval: Before each use or daily

Test the safety-interlock system before you use the machine each time. If the safety system does not operate as described below, have an Authorized Service Dealer repair the safety system immediately.

1. Sit on the seat, engage the parking brake, and move the blade-control switch (PTO) to the ON position. Try starting the engine; the engine should not crank.
2. Sit on the seat, engage the parking brake, and move the blade-control switch (PTO) to the OFF position. Move either motion-control lever (out of the NEUTRAL-LOCK position). Try starting the engine; the engine should not crank. Repeat for other control lever.
3. Sit on the seat, engage the parking brake, move the blade-control switch (PTO) to the OFF position, and move the motion-control levers to the NEUTRAL-LOCK position. Start the engine. While the engine is running, release the parking brake, engage the blade-control switch (PTO), and rise slightly from the seat; the engine should shut off.

4. Sit on the seat, engage the parking brake, move the blade-control switch (PTO) to the OFF position, and move the motion-control levers to NEUTRAL-LOCK position. Start the engine. While the engine is running, center either motion-control lever and move it forward or reverse; the engine should shut off. Repeat for other motion-control lever.
5. Sit on the seat, disengage the parking brake, move the blade-control switch (PTO) to the OFF position, and move the motion-control levers to NEUTRAL-LOCK position. Try starting the engine; the engine should not crank.

Positioning the Seat

The seat can move forward and backward. Position the seat where you have the best control of the machine and are most comfortable (Figure 8).

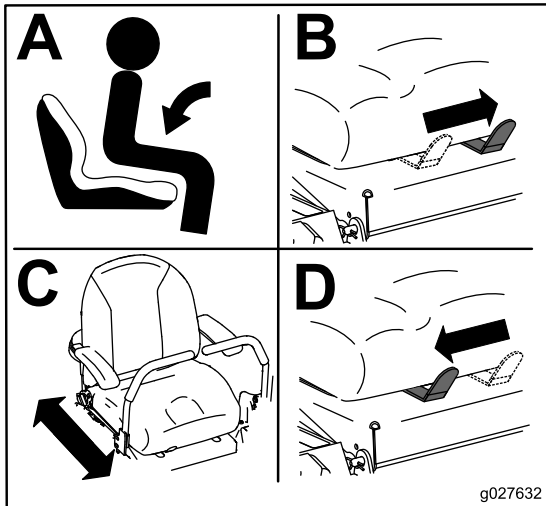

Figure 8

g027632

Adjusting the MyRide™ Suspension System

Machines with MyRide Only

The MyRide™ suspension system adjusts to provide a smooth and comfortable ride. You can adjust the rear springs to quickly and easily change the suspension system. Position the suspension system where you are most comfortable (Figure 9 and Figure 10).

The slots for the rear springs have detent positions for reference. You can position the rear springs anywhere in the slot, not just in the detent positions.

The following graphic shows the position for a soft or firm ride and the different detent positions (Figure 9).

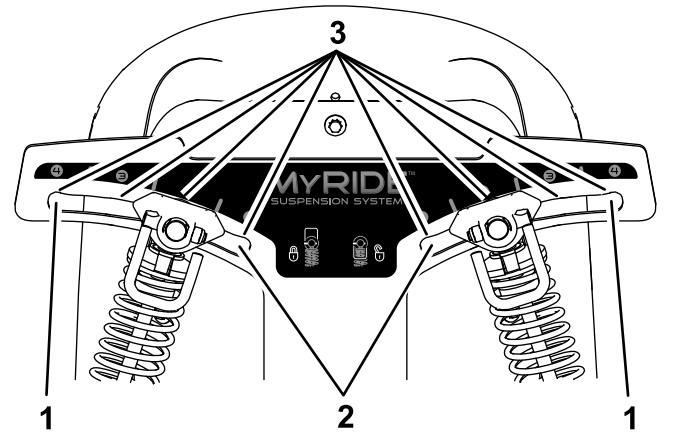
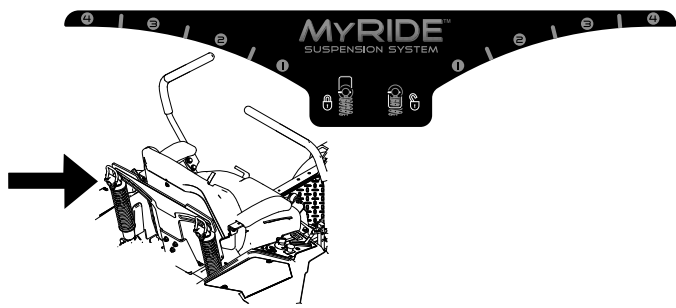

Figure 9

1. Firmest position
2. Softest position
3. Detents in the slots

Note: Ensure that the left and right springs are always adjusted to the same positions.



g335104

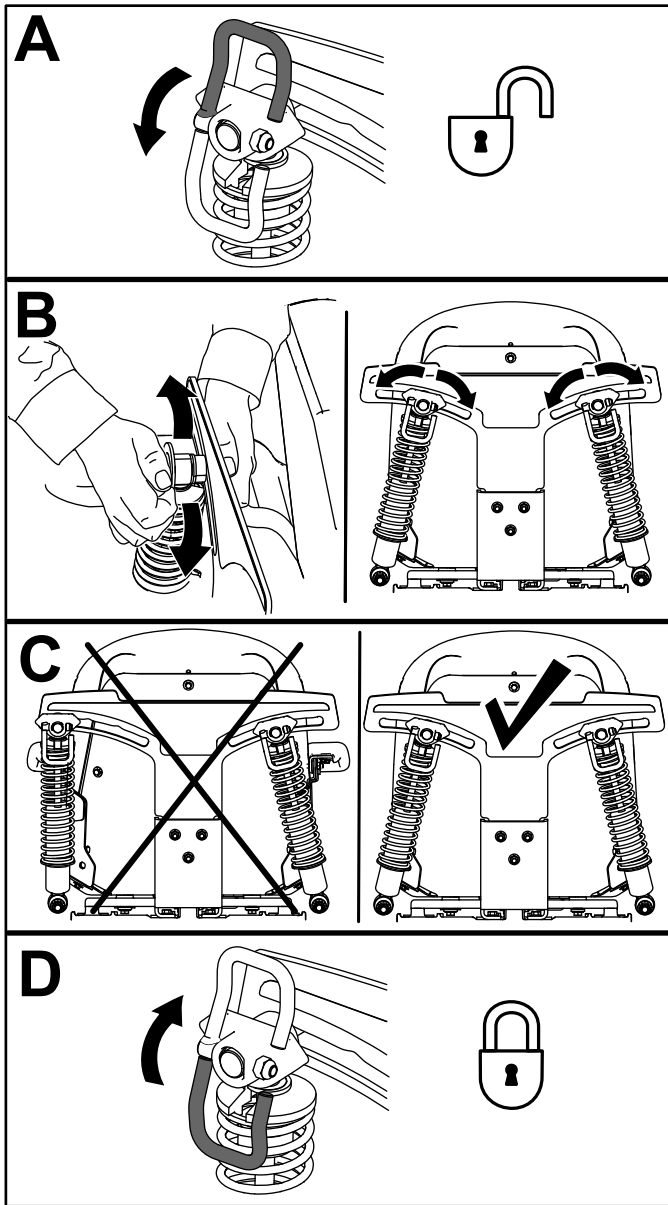

g195745

Figure 10

Adjusting the Motion-Control Levers

Adjusting the Height

You can adjust the motion-control levers higher or lower for maximum comfort (Figure 11).

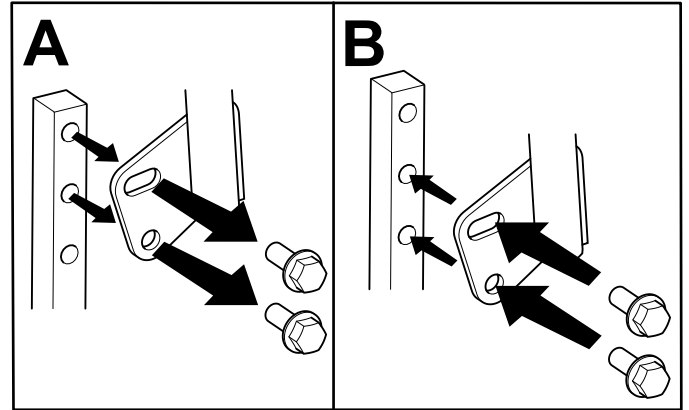

g333847

Figure 11

Adjusting the Tilt

You can adjust the motion-control levers forward or rearward for your comfort.

1. Loosen the upper bolt holding the control lever to the control-arm shaft.
2. Loosen the lower bolt just enough to pivot the control lever forward or rearward.

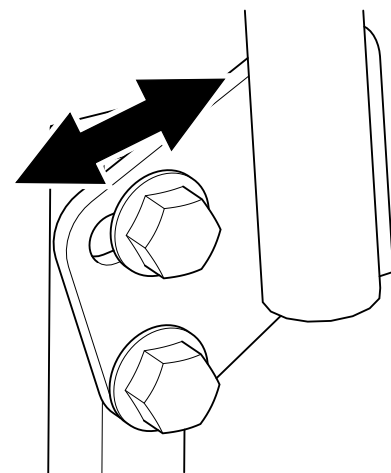

g333846

Figure 12

3. Tighten both bolts to secure the control lever in the new position.
4. Repeat the adjustment for the other control lever.

During Operation

During Operation Safety

General Safety

- The owner/operator can prevent and is responsible for accidents that may cause personal injury or property damage.
- Use your full attention while operating the machine. Do not engage in any activity that causes distractions; otherwise, injury or property damage may occur.
- Do not operate the machine while ill, tired, or under the influence of alcohol or drugs.
- Contacting the blade can result in serious personal injury. Shut off the engine, remove the key, and wait for all moving parts to stop before leaving the operating position. When you turn the key to the OFF position, the engine should shut off and the blade should stop. If not, stop using your machine immediately and contact an Authorized Service Dealer.
- Operate the machine only in good visibility and appropriate weather conditions. Do not operate the machine when there is the risk of lightning.
- Keep your hands and feet away from the cutting units. Keep clear of the discharge opening.
- Do not mow in reverse unless it is absolutely necessary. Always look down and behind you before moving the machine in reverse.
- Use extreme care when approaching blind corners, shrubs, trees, or other objects that may block your view.
- Stop the blades whenever you are not mowing.
- If the machine strikes an object or starts to vibrate, immediately shut off the engine, remove the key (if equipped), and wait for all moving parts to stop before examining the machine for damage. Make all necessary repairs before resuming operation.
- Slow down and use caution when making turns and crossing roads and sidewalks with the machine. Always yield the right-of-way.
- Before you leave the operating position, do the following:
 - Park the machine on a level surface.
 - Disengage the power takeoff and lower the attachments.
 - Engage the parking brake.
 - Shut off the engine and remove the key.
 - Wait for all moving parts to stop.

- Operate the engine only in well-ventilated areas. Exhaust gases contain carbon monoxide, which is lethal if inhaled.
- Never leave a running machine unattended.
- Attach towed equipment to the machine only at the hitch point.
- Do not operate the machine unless all guards and safety devices, such as the deflectors, are in place and functioning properly. Replace worn or deteriorated parts when necessary.
- Use only accessories and attachments approved by Toro.
- This machine produces sound levels in excess of 85 dBA at the operator's ear and can cause hearing loss through extended periods of exposure.

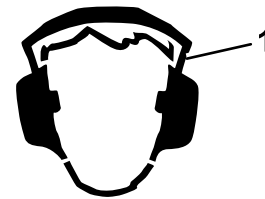

Figure 13

g229846

1. Wear hearing protection.

-
- Clean grass and debris from the cutting unit, drives, muffler, and engine to help prevent fires.
 - Start the engine with your feet well away from the blades.
 - Be aware of the mower discharge path and direct the discharge away from others. Avoid discharging material against a wall or obstruction because the material may ricochet back toward you.
 - Stop the blades, slow down the machine, and use caution when crossing surfaces other than grass or when transporting the machine to and from the operating area.
 - Do not change the engine governor speed or overspeed the engine.
 - Children are often attracted to the machine and the mowing activity. Never assume that children will remain where you last saw them.
 - Keep children out of the operating area and under the watchful care of a responsible adult other than the operator.
 - Be alert and shut off the machine if children enter the operating area.
 - Before backing up or turning the machine, look down and all around for small children.
 - Do not carry children on the machine, even when the blades are not moving. Children could fall

off and be seriously injured or prevent you from safely operating the machine. Children who have been given rides in the past could appear in the operating area without warning and be run over or backed over by the machine.

Slope Safety

- Slopes are a major factor related to loss of control and rollover accidents, which can result in severe injury or death. The operator is responsible for safe slope operation. Operating the machine on any slope requires extra caution. Before using the machine on a slope, do the following:
 - Review and understand the slope instructions in the manual and on the machine.
 - Use an angle indicator to determine the approximate slope angle of the area.
 - Never operate on slopes greater than 15°.
 - Evaluate the site conditions of the day to determine if the slope is safe for machine operation. Use common sense and good judgment when performing this evaluation. Changes in the terrain, such as moisture, can quickly affect the operation of the machine on a slope.
- Identify hazards at the base of the slope. Do not operate the machine near drop-offs, ditches, embankments, water, or other hazards. The machine could suddenly roll over if a wheel goes over the edge or the edge collapses. Keep a safe distance (twice the width of the machine) between the machine and any hazard. Use a walk-behind mower and/or a hand trimmer to mow the grass in these areas.
- Avoid starting, stopping, or turning the machine on slopes. Avoid making sudden changes in speed or direction; turn slowly and gradually.
- Do not operate a machine under any conditions where traction, steering, or stability is in question. Be aware that operating the machine on wet grass, across slopes, or downhill may cause the machine to lose traction. Loss of traction to the drive wheels may result in sliding and a loss of braking and steering. The machine can slide even if the drive wheels are stopped.
- Remove or mark obstacles such as ditches, holes, ruts, bumps, rocks, or other hidden hazards. Tall grass can hide obstacles. Uneven terrain could overturn the machine.
- Use extra care while operating with accessories or attachments, such as grass-collection systems. These can change the stability of the machine

and cause a loss of control. Follow directions for counterweights.

- If possible, keep the deck lowered to the ground while operating on slopes. Raising the deck while operating on slopes can cause the machine to become unstable.

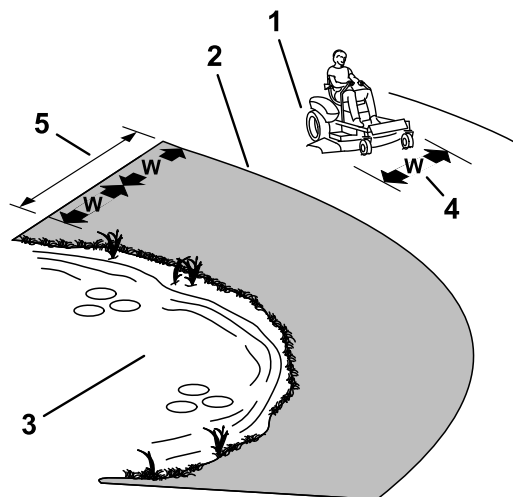

Figure 14

g229111

- Safe Zone—use the machine here on slopes less than 15° or flat areas.
- Danger Zone—use a walk-behind mower and/or a hand trimmer on slopes greater than 15° and near drop-offs or water.
- Water
- W = Width of the machine
- Keep a safe distance (twice the width of the machine) between the machine and any hazard.

Towing Safety

- Do not attach towed equipment except at the hitch point.
- Do not use the machine as a towing vehicle unless it has a hitch installed.
- Do not exceed the weight limits for towed equipment and towing on slopes. The towed weight must not exceed the weight of the machine and operator.
- Never allow children or others near the towed equipment.
- On slopes, the weight of the towed equipment may cause loss of traction, increased risk of rollover, and loss of control. Reduce the towed weight and slow down.
- The stopping distance may increase with the weight of a towed load. Travel slowly and allow extra distance to stop.
- Make wide turns to keep the attachment clear of the machine.

Operating the Parking Brake

Always engage the parking brake when you stop the machine or leave it unattended.

Engaging the Parking Brake

Park the machine on a level surface.

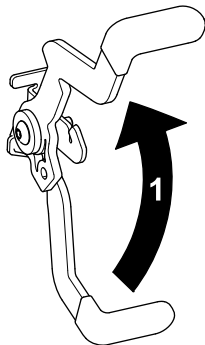

Figure 15

g188778

1. Pull the parking brake up.

Disengaging the Parking Brake

To disengage the parking brake, pull the lever out of the detent slot and toward you, then push it down (Figure 16).

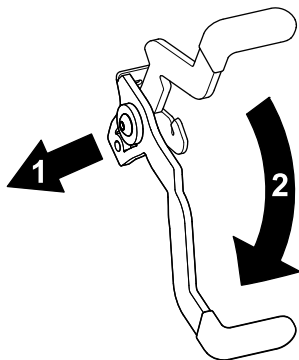
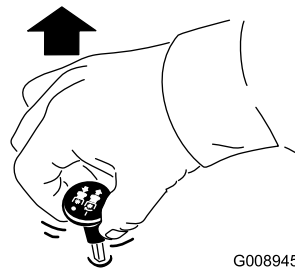

Figure 16

g188777

1. Push the parking brake out of the detent slot and toward you.
2. Push the parking brake down.

Engaging the Blade-Control Switch (PTO)



G008945

g008945

Figure 17

Note: Always engage the blades with the throttle in the FAST position (Figure 18).

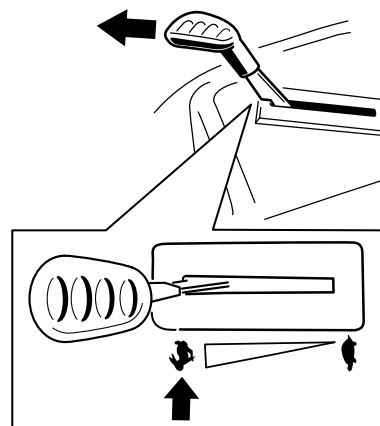
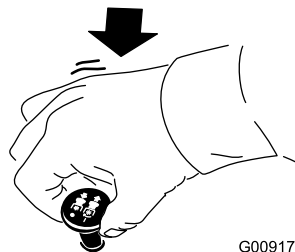

Figure 18

g295538

Disengaging the Blade-Control Switch (PTO)



G009174

g009174

Figure 19

Operating the Throttle

You can move the throttle control between the FAST and SLOW positions (Figure 20).

Always use the FAST position when engaging the PTO.

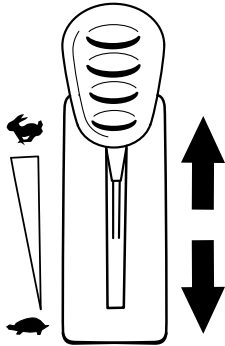

Figure 20

g295539

Operating the Choke

Use the choke to start a cold engine.

1. Pull up the choke knob to engage the choke before using the key switch (Figure 21).
2. Push down the choke knob to disengage the choke after the engine has started (Figure 21).

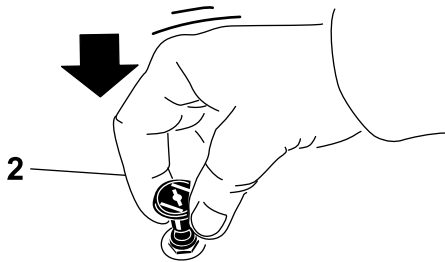
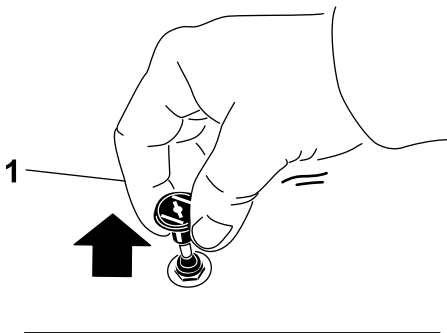

Figure 21

g295540

1. ON position
2. OFF position

Operating the Key Switch

1. Turn the key to the START position (Figure 22).

Note: When the engine starts, release the key.

Important: Do not engage the starter motor for more than 5 seconds at a time. If the engine fails to start, wait 10 seconds between attempts. Failure to follow these instructions can burn out the starter motor.

Note: You may need multiple attempts to start the engine when you start it the first time after the fuel system has been without fuel completely.

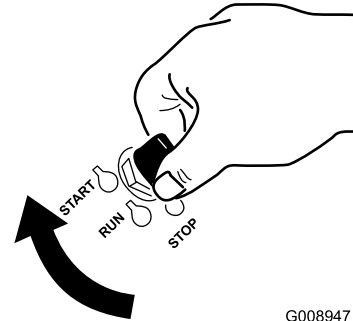

Figure 22

G008947

g008947

2. Turn the key to the STOP position to shut off the engine.

Starting the Engine

Note: A warm or hot engine may not require choking.

Important: Do not engage the starter for more than 5 seconds at a time. Engaging the starter motor for more than 5 seconds can damage the starter motor. If the engine fails to start, wait 10 seconds before operating the engine starter again.

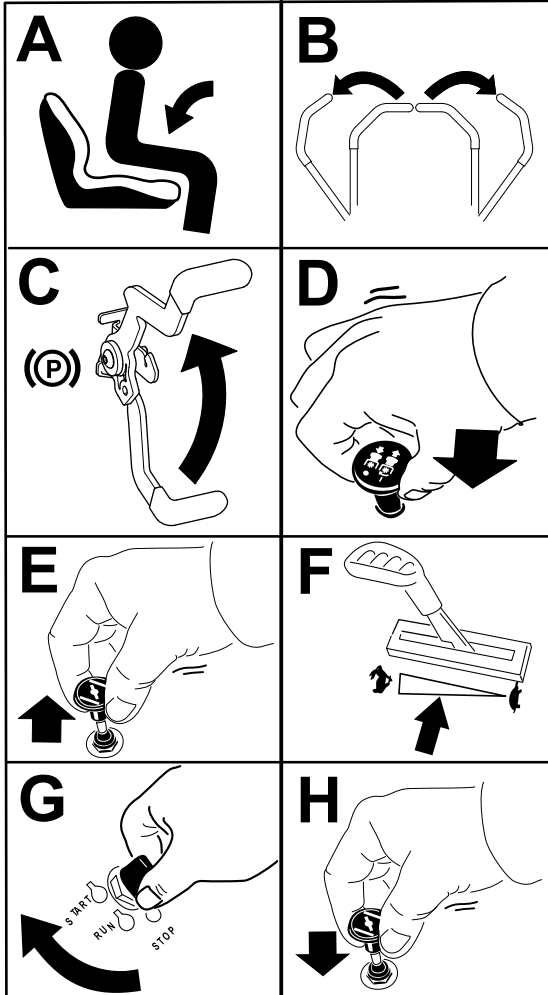

Figure 23

g297307

Shutting Off the Engine

1. Disengage the blades by moving the blade-control switch to the OFF position.
2. Engage the parking brake.
3. Move the throttle control to between the half and full throttle position.
4. Turn the key to the OFF position and remove the key.

⚠ CAUTION

Children or bystanders may be injured if they move or attempt to operate the machine while it is unattended.

Always remove the key and engage the parking brake when leaving the machine unattended.

Using the Motion-Control Levers

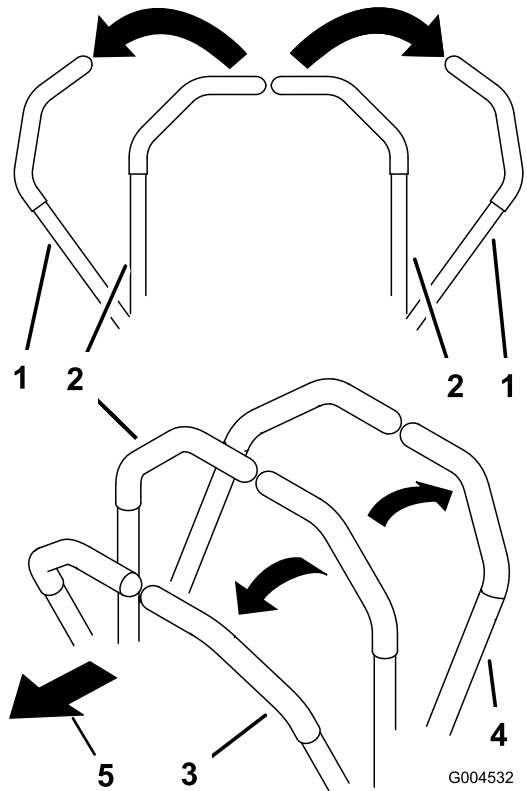

Figure 24

G004532

g004532

- | | |
|---|---------------------|
| 1. Motion-control lever—NEUTRAL-LOCK position | 4. Backward |
| 2. Center, unlocked position | 5. Front of machine |
| 3. Forward | |

Driving the Machine

The drive wheels turn independently, powered by hydraulic motors on each axle. You can turn 1 side in reverse while you turn the other forward, causing the machine to spin rather than turn. This greatly improves the machine maneuverability but may require some time for you to adapt to how it moves.

The throttle control regulates the engine speed as measured in rpm (revolutions per minute). Place the throttle control in the FAST position for best performance. Always operate in the full throttle position when mowing.

⚠ WARNING

The machine can spin very rapidly. You may lose control of the machine and cause personal injury or damage to the machine.

- Use caution when making turns.
- Slow the machine down before making sharp turns.

Driving Forward

Note: The engine shuts off when you move the traction-control with the parking brake engaged.

Note: Always use caution when turning.

1. Disengage the parking brake; refer to [Disengaging the Parking Brake \(page 21\)](#).
2. Move the levers to the center, unlocked position.
3. To go forward, slowly push the motion-control levers forward ([Figure 25](#)).

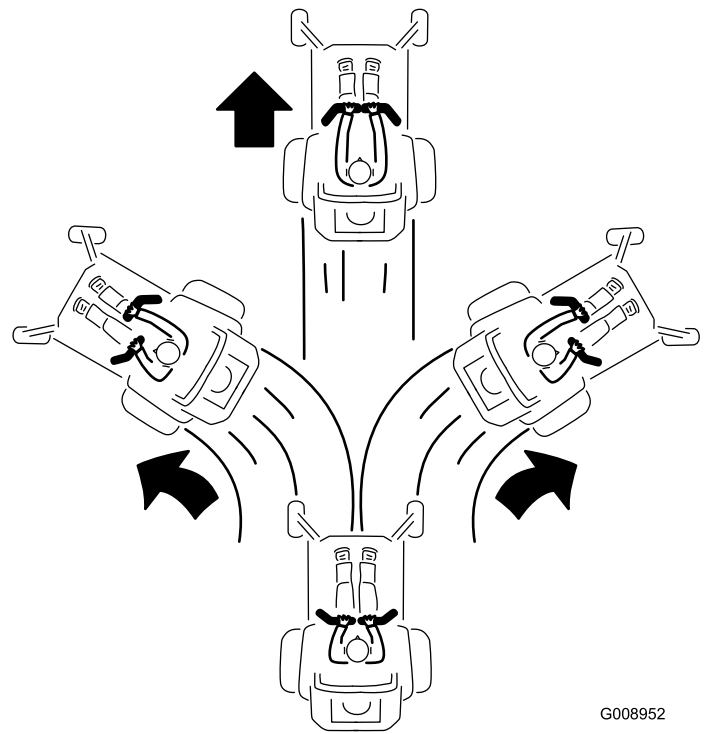

Figure 25

G008952
g008952

4. To stop the machine, pull the motion-control levers to the NEUTRAL position.

Driving Backward

Note: Always use caution when backing up and turning.

1. Move the levers to the center, unlocked position.
2. To go backward, slowly pull the motion-control levers rearward ([Figure 26](#)).

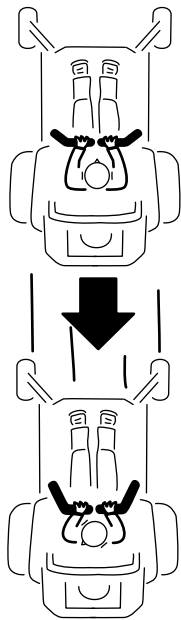

G008953

g008953

Figure 26

Adjusting the Height of Cut

The machine is equipped with a foot pedal deck-lift system. You can use the foot pedal to lift the deck briefly to avoid obstacles and to raise the deck.

You can adjust the height of cut from 38 to 114 mm (1-1/2 to 4-1/2 inches) in 6 mm (1/4 inch) increments by moving the height-of-cut pin into different hole locations.

1. Push on the deck-lift pedal with your foot to raise the mower deck.
2. To adjust, remove the pin from the height-of-cut bracket (Figure 27).
3. Select a hole in the height-of-cut system corresponding to the desired height of cut and insert the pin (Figure 27).
4. Lower the deck slowly until the lever makes contact with the pin.

Using the Side Discharge

The mower has a hinged grass deflector that disperses clippings to the side and down toward the turf.

▲ DANGER

Without a grass deflector, discharge cover, or a complete grass-catcher assembly mounted in place, you and others are exposed to blade contact and thrown debris. Contact with rotating mower blade(s) and thrown debris will cause injury or death.

- Never remove the grass deflector from the mower deck because the grass deflector routes material down toward the turf. If the grass deflector is ever damaged, replace it immediately.
- Never put your hands or feet under the mower deck.
- Never try to clear the discharge area or mower blades unless you move the blade-control switch (PTO) to the OFF position, rotate the key switch to the OFF position, and remove the key from the key switch.
- Make sure that the grass deflector is in the down position.

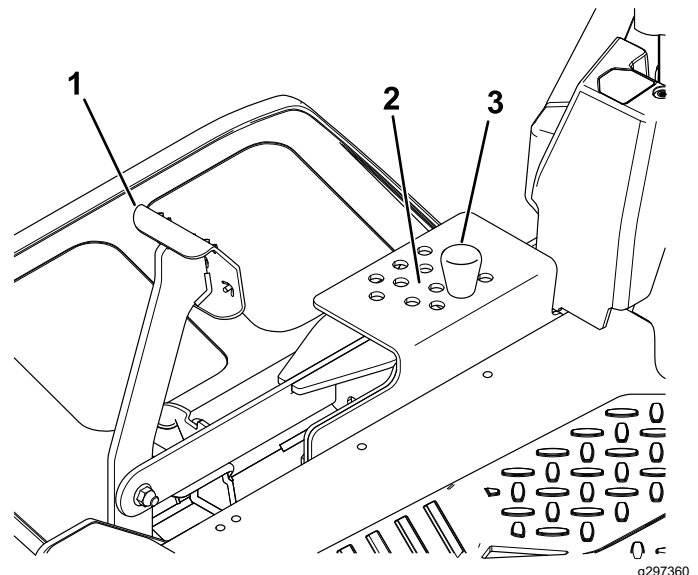

Figure 27

1. Deck-lift pedal
2. Height-of-cut positions
3. Pin

g297360

Adjusting the Anti-Scalp Rollers

Whenever you change the height of cut, adjust the height of the anti-scalp rollers.

Note: Adjust the anti-scalp rollers so that the rollers do not touch the ground in normal, flat mowing areas.

1. Park the machine on a level surface, disengage the blade-control switch and engage the parking brake; refer to [Engaging the Parking Brake \(page 21\)](#).
2. Shut off the engine, remove the key, and wait for all moving parts to stop before leaving the operating position.
3. Adjust the anti-scalp rollers as shown in [Figure 28](#).

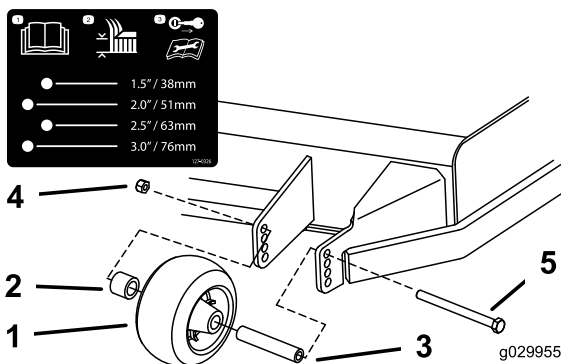

Figure 28

- | | |
|----------------------|---------------|
| 1. Anti-scalp roller | 4. Flange nut |
| 2. Spacer | 5. Bolt |
| 3. Bushing | |

Operating Tips

Maximizing Air Circulation

For best mowing and maximum air circulation, operate the engine at the FAST position. Air is required to thoroughly cut grass clippings, so do not set the height-of-cut so low as to totally surround the mower deck in uncut grass. Always try to have 1 side of the mower deck free from uncut grass, which allows air to be drawn into the mower deck.

Cutting a Lawn for the First Time

Cut grass slightly longer than normal to ensure that the cutting height of the mower deck does not scalp any uneven ground. However, the cutting height used in the past is generally the best one to use. When cutting grass longer than 15 cm (6 inches) tall, you may want to cut the lawn twice to ensure an acceptable quality of cut.

Cutting a Third of the Grass Blade

It is best to cut only about a third of the grass blade. Cutting more than that is not recommended unless grass is sparse, or it is late fall when grass grows more slowly.

Alternating the Mowing Direction

Alternate the mowing direction to keep the grass standing straight. This also helps disperse clippings, which enhances decomposition and fertilization.

Mowing at Correct Intervals

Grass grows at different rates at different times of the year. To maintain the same cutting height, mow more often in early spring. As the grass growth rate slows in mid summer, mow less frequently. If you cannot mow for an extended period, first mow at a high cutting height, then mow again 2 days later at a lower height setting.

Mowing at Slower Speeds

In certain conditions, mowing at a slower ground speed can improve cut quality.

Avoiding Cutting Too Low

When mowing uneven turf, raise the cutting height to avoid scalping the turf.

Stopping the Machine

If you must stop the forward motion of the machine while mowing, a clump of grass clippings may drop onto your lawn. To avoid this, move onto a previously cut area with the blades engaged or you can disengage the mower deck while moving forward.

Keeping the Underside of the Mower Deck Clean

Clean clippings and dirt from the underside of the mower deck after each use. If grass and dirt build up inside the mower deck, cutting quality will eventually become unsatisfactory.

Maintaining the Blade(s)

Maintain a sharp blade throughout the cutting season because a sharp blade cuts cleanly without tearing or shredding the grass blades. Tearing and shredding turns grass brown at the edges, which slows growth and increases the chance of disease. Check the mower blades after each use for sharpness, and for any wear or damage. File down any nicks and sharpen the blades as necessary. If a blade is damaged or worn, replace it immediately with a genuine Toro replacement blade. Refer to [Servicing the Cutting Blades \(page 41\)](#).

After Operation

After Operation Safety

General Safety

- Engage the parking brake, shut off the engine, remove the key, and wait for all moving parts to stop before leaving the operator's position. Allow the machine to cool before servicing, adjusting, fueling, cleaning, or storing it.
- Clean grass and debris from the cutting unit, muffler, drives, grass catcher, and engine compartment to help prevent fires. Clean up oil or fuel spills.
- Shut off the fuel and remove the key before storing or transporting the machine.

Cleaning the Machine

Service Interval: After each use

Important: You can wash the machine with a mild detergent and water. Do not pressure wash the machine. Avoid excessive use of water, especially near the control panel, under the seat, around the engine, hydraulic pumps, and motors.

1. Park the machine on a level surface, disengage the blade-control switch, and engage the parking brake.
2. Shut off the engine and wait for all moving parts to stop before leaving the operating position.
3. Clean grass and debris from cutting unit, muffler, drives, grass catcher, and engine.

Pushing the Machine by Hand

1. Park the machine on a level surface, disengage the blade-control switch, and engage the parking brake.
2. Shut off the engine, remove the key, and wait for all moving parts to stop before leaving the operating position.
3. Locate the bypass levers on the frame on both sides of the engine.
4. Move the bypass levers forward through the slotted hole and down to lock them in place ([Figure 29](#)).

Note: Do this for each lever.

⚠ WARNING

Contact with hot surfaces may cause personal injury.

Keep your hands, feet, face, clothing and other body parts away the engine, muffler and other hot surfaces.

⚠ WARNING

The machine could unintentionally move while the bypass levers are locked forward in the slot and injure you or bystanders.

Lock the bypass levers rearward after moving the machine.

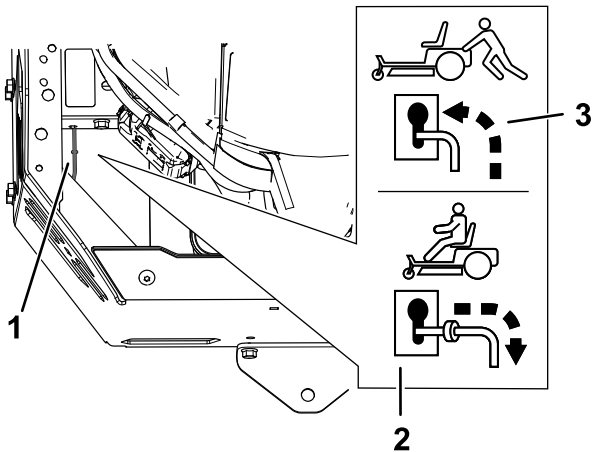

Figure 29

g298692

1. Bypass-lever locations
2. Lever position for operating the machine
3. Lever position for pushing the machine

5. Disengage the parking brake.
6. Move the machine as required.

Important: Always push the machine by hand. Do not tow the machine, because towing may damage it.

7. Engage the parking brake.
8. Move both bypass levers rearward and down through the slotted hole to lock them in place.

Transporting the Machine

Use a heavy-duty trailer or truck to transport the machine. Use a full-width ramp. Ensure that the trailer or truck has all the necessary brakes, lighting, and marking as required by law. Please carefully read all the safety instructions. Knowing this information could help you or bystanders avoid injury. Refer to your local ordinances for trailer and tie-down requirements.

⚠ WARNING

Driving on the street or roadway without turn signals, lights, reflective markings, or a slow-moving-vehicle emblem is dangerous and can lead to accidents, causing personal injury.

Do not drive the machine on a public street or roadway.

Selecting a Trailer

⚠ WARNING

Loading a machine onto a trailer or truck increases the possibility of tip-over and could cause serious injury or death (Figure 30).

- Use only a full-width ramp; do not use individual ramps for each side of the machine.
- Do not exceed a 15-degree angle between the ramp and the ground or between the ramp and the trailer or truck.
- Ensure that the length of the ramp is at least 4 times as long as the height of the trailer or truck bed to the ground. This ensures that the ramp angle does not exceed 15 degrees on flat ground.

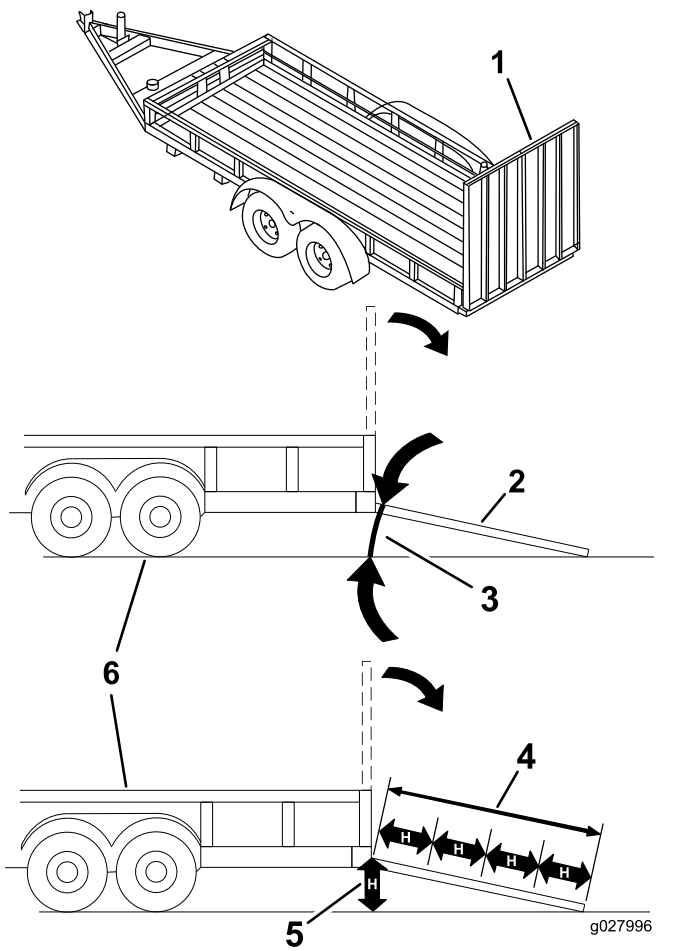

Figure 30

- | | |
|---|---|
| 1. Full-width ramp in stowed position | 4. Ramp is at least 4 times as long as the height of the trailer or truck bed to the ground |
| 2. Side view of full-width ramp in loading position | 5. H=height of the trailer or truck bed to the ground |
| 3. Not greater than 15 degrees | 6. Trailer |

Loading the Machine

⚠ WARNING

Loading a machine onto a trailer or truck increases the possibility of tip-over and could cause serious injury or death.

- Use extreme caution when operating a machine on a ramp.
- Back the machine up the ramp and drive it forward down the ramp.
- Avoid sudden acceleration or deceleration while driving the machine on a ramp as this could cause a loss of control or a tip-over situation.

1. If you are using a trailer, connect it to the towing vehicle and connect the safety chains.
2. If applicable, connect the trailer brakes and lights.
3. Lower the ramp, ensuring that the angle between the ramp and the ground does not exceed 15 degrees (Figure 30).
4. Back the machine up the ramp (Figure 31).

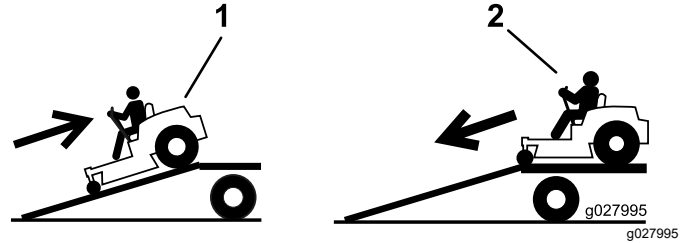

Figure 31

1. Back the machine up the ramp.
2. Drive the machine forward down the ramp.

5. Shut off the engine, remove the key, and engage the parking brake.
6. Tie down the machine near the front caster wheels and the rear frame with straps, chains, cable, or ropes (Figure 32). Refer to local regulations for tie-down requirements.

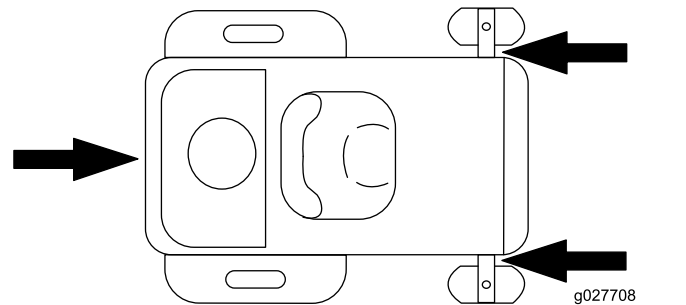

Figure 32

1. Tie-down points

Unloading the Machine

1. Lower the ramp, ensuring that the angle between the ramp and the ground does not exceed 15 degrees (Figure 30).
2. Drive the machine forward down the ramp (Figure 31).

Maintenance

Note: Determine the left and right sides of the machine from the normal operating position.

Maintenance Safety

- If you leave the key in the switch, someone could accidentally start the engine and seriously injure you or other bystanders. Remove the key from the switch before you perform any maintenance.
- Before you leave the operator's position, do the following:
 - Park the machine on a level surface.
 - Disengage the drives.
 - Engage the parking brake.
 - Shut off the engine and remove the key.
 - Allow machine components to cool before performing maintenance.
- Do not allow untrained personnel to service the machine.
- Keep your hands and feet away from moving parts or hot surfaces. If possible, do not make adjustments with the engine running.
- Carefully release pressure from components with stored energy.
- Check the parking brake operation frequently. Adjust and service it as required.
- Never tamper with safety devices. Check their proper operation regularly.
- Clean grass and debris from the cutting unit, muffler, drives, grass catcher, and engine compartment to prevent fires.
- Clean up oil or fuel spills and remove fuel-soaked debris.
- Do not rely on hydraulic or mechanical jacks to support the machine; support the machine with jack stands whenever you raise the machine.
- Keep all parts in good working condition and all hardware tightened, especially the blade-attachment hardware. Replace all worn or damaged decals.
- Disconnect the cable from the negative terminal of the battery before repairing the machine.
- To ensure optimum performance, use only genuine Toro replacement parts and accessories. Replacement parts and accessories made by other manufacturers could be dangerous, and such use could void the product warranty.

Recommended Maintenance Schedule(s)

Maintenance Service Interval	Maintenance Procedure
Before each use or daily	<ul style="list-style-type: none"> • Check the safety-interlock system. • Check the engine-oil level. • Inspect the blades. • Inspect the grass deflector for damage.
After each use	<ul style="list-style-type: none"> • Clean grass and debris from the cutting unit, muffler, drives, grass catcher, and engine.
Every 25 hours	<ul style="list-style-type: none"> • Clean the air-cleaner foam element (more often in dusty, dirty conditions). • Check tire pressure. • Check the belts for wear or cracks.
Every 100 hours	<ul style="list-style-type: none"> • Replace the air-cleaner foam element (more often in dusty, dirty conditions). • Remove and clean the blower housing and any other cooling shrouds (more often under extremely dusty, dirty conditions). • Replace the in-line fuel filter.
Every 100 hours or yearly, whichever comes first	<ul style="list-style-type: none"> • Replace the paper air-cleaner element (more often in dirty or dusty conditions). • Change the engine oil and oil filter (more often in dirty or dusty conditions).
Every 500 hours	<ul style="list-style-type: none"> • Replace the spark plug(s).
Before storage	<ul style="list-style-type: none"> • Charge the battery and disconnect the battery cables. • Perform all maintenance procedures listed above before storage. • Paint any chipped surfaces.

Important: Refer to your engine owner's manual for additional maintenance procedures.

⚠ CAUTION

If you leave the key in the switch, someone could accidentally start the engine and seriously injure you or other bystanders.

Shut off the engine and remove the key from the switch before you perform any maintenance.

Engine Maintenance

Engine Safety

- Keep your hands, feet, face, other body parts, and clothing away from the muffler and other hot surfaces. Allow engine components to cool before performing maintenance.
- Do not change the engine governor speed or overspeed the engine.

Servicing the Air Cleaner

Service Interval: Every 25 hours—Clean the air-cleaner foam element (more often in dusty, dirty conditions).

Every 100 hours—Replace the air-cleaner foam element (more often in dusty, dirty conditions).

Note: Service the air cleaner more frequently (every few hours) if operating conditions are extremely dusty or sandy.

Removing the Foam and Paper Elements

1. Park the machine on a level surface, disengage the blade-control switch, and engage the parking brake.
2. Shut off the engine, remove the key, and wait for all moving parts to stop before leaving the operating position.
3. Clean around the air-cleaner cover to prevent dirt from getting into the engine and causing damage.
4. Release the retaining clamps on the air cleaner and pull the air-cleaner cover off the air-cleaner body

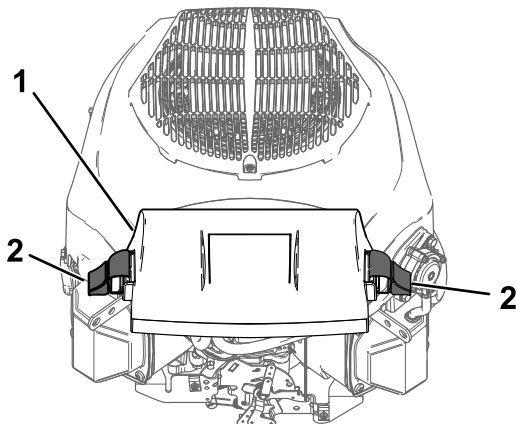

Figure 33

g305607

1. Cover
2. Retaining clamp

5. Separate the foam and paper elements (Figure 34).

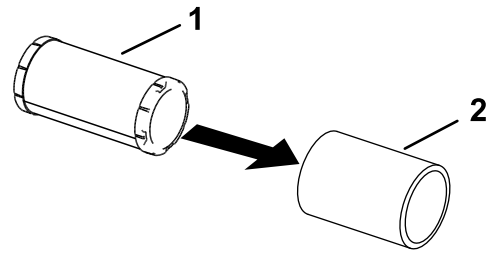

Figure 34

g305608

1. Paper element
2. Foam element

Servicing the Foam Element

1. Wash the foam element in liquid soap and warm water. When the element is clean, rinse it thoroughly.
2. Dry the element by squeezing it in a clean cloth.

Important: Replace the foam element if it is torn or worn.

3. Lightly oil the foam element using new engine oil and squeeze out any excess oil.

Servicing the Paper Air-Cleaner Element

Service Interval: Every 100 hours or yearly, whichever comes first—Replace the paper air-cleaner element (more often in dirty or dusty conditions).

1. Clean the paper element by tapping it gently to remove dust.

Note: If it is very dirty, replace the paper element with a new one.

2. Inspect the element for tears, an oily film, or damage to the rubber seal.
3. Replace the paper element if it is damaged.

Important: Do not clean the paper filter.

Installing the Air Cleaner

1. Install the foam pre-cleaner element over the paper element.

Note: Ensure that you do not damage the elements.

2. Install the air-cleaner elements onto the air-cleaner base.
3. Install the cover and secure it with the retaining clamps (Figure 33).

Servicing the Engine Oil

Engine-Oil Specifications

Oil Type: Detergent oil (including synthetic) of API service SJ or higher

Crankcase Capacity: 1.9 L (64 fl oz) with oil filter

Viscosity: See the table below.

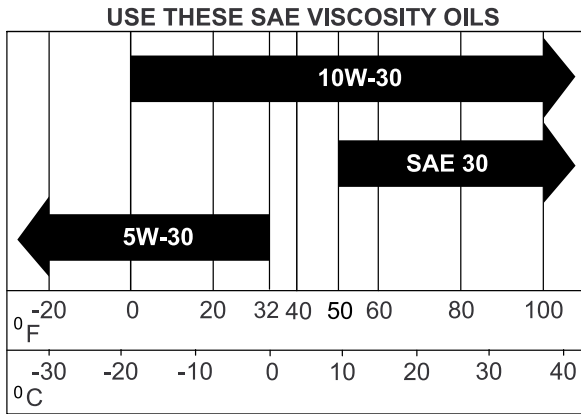

Figure 35

Checking the Engine-Oil Level

Service Interval: Before each use or daily

Note: Check the oil when the engine is cold.

Important: If you overfill or underfill the engine crankcase with oil and run the engine, you may damage the engine.

1. Park the machine on a level surface, disengage the blade-control switch, and engage the parking brake.
2. Shut off the engine, remove the key, and wait for all moving parts to stop before leaving the operating position.

Note: Ensure that the engine is cool so that the oil has had time to drain into the sump.

3. To keep dirt, grass clippings, etc., out of the engine, clean the area around the oil-fill cap and dipstick before removing it (Figure 36).

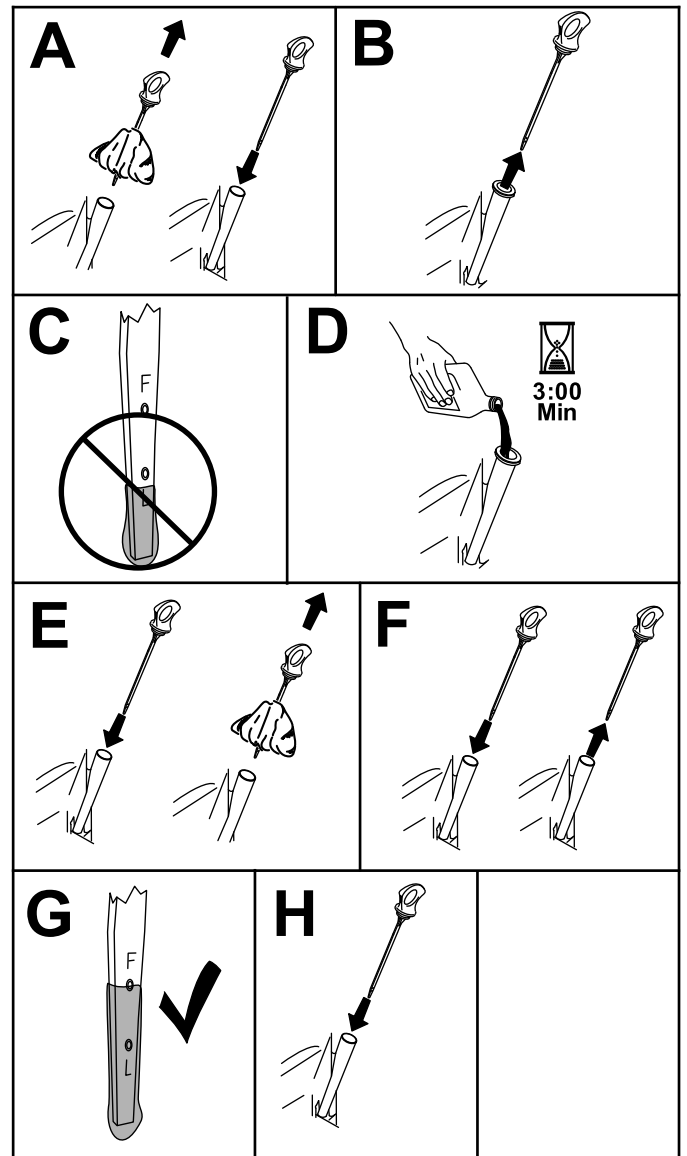

Figure 36

Changing the Engine Oil and Oil Filter

Service Interval: Every 100 hours or yearly, whichever comes first—Change the engine oil and oil filter (more often in dirty or dusty conditions).

1. Park the machine on a level surface, disengage the blade-control switch, and engage the parking brake.
2. Shut off the engine, remove the key, and wait for all moving parts to stop before leaving the operating position.
3. Drain the oil from the engine (Figure 37).

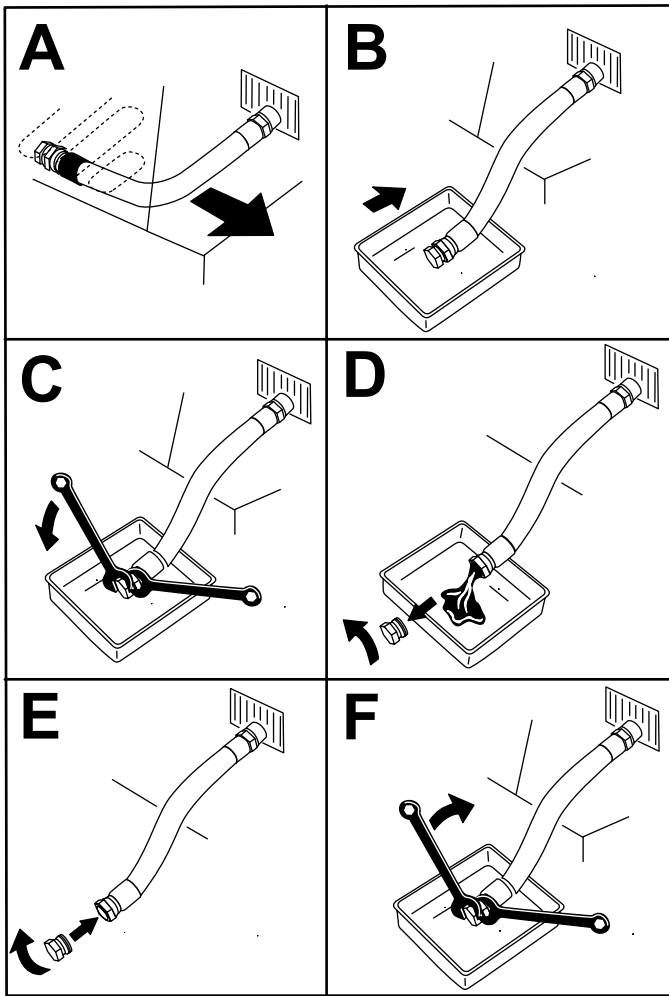
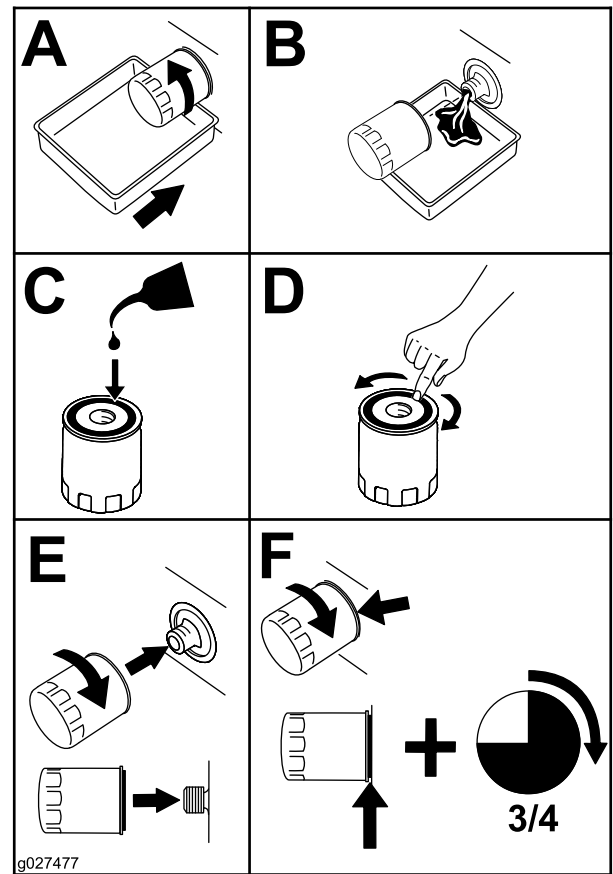

Figure 37

g225280

4. Change the engine-oil filter (Figure 38).

Note: Ensure that the oil-filter gasket touches the engine and then turn the filter an extra $\frac{3}{4}$ turn.



g027477

g027477

Figure 38

5. Slowly pour approximately 80% of the specified oil into the filler tube and slowly add the additional oil to bring it to the Full mark (Figure 39).

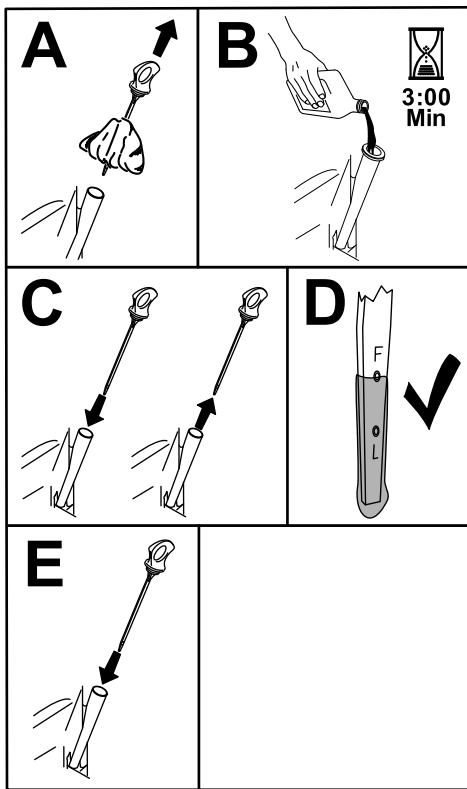

Figure 39

g365790

- Dispose of the used oil at a recycling center.

Servicing the Spark Plug

Service Interval: Every 500 hours—Replace the spark plug(s).

Ensure that the air gap between the center and side electrodes is correct before installing the spark plug. Use a spark plug wrench for removing and installing the spark plug and a gapping tool or feeler gauge to check and adjust the air gap. Install a new spark plug if necessary.

Type: Champion® XC12YC

Air gap: 0.76 mm (0.03 inch)

Removing the Spark Plug

- Park the machine on a level surface, disengage the blade-control switch (PTO), and engage the parking brake.
- Shut off the engine, remove the key, and wait for all moving parts to stop before leaving the operating position. Allow the engine to cool.
- Clean the area around the base of the plug to keep dirt and debris out of the engine.
- Remove the spark plug (Figure 40).

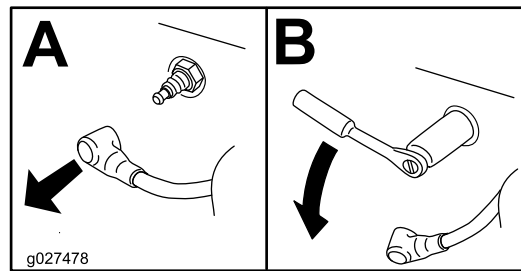

Figure 40

g027478

Checking the Spark Plug

Important: Do not clean the spark plug(s). Always replace the spark plug(s) when it has a black coating, worn electrodes, an oily film, or cracks.

If you see light brown or gray on the insulator, the engine is operating properly. A black coating on the insulator usually means the air cleaner is dirty.

Set the gap to 0.75 mm (0.03 inch).

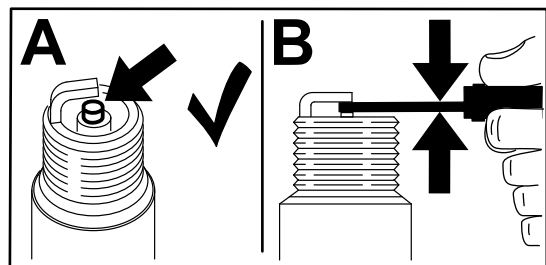

Figure 41

g206628

Installing the Spark Plug

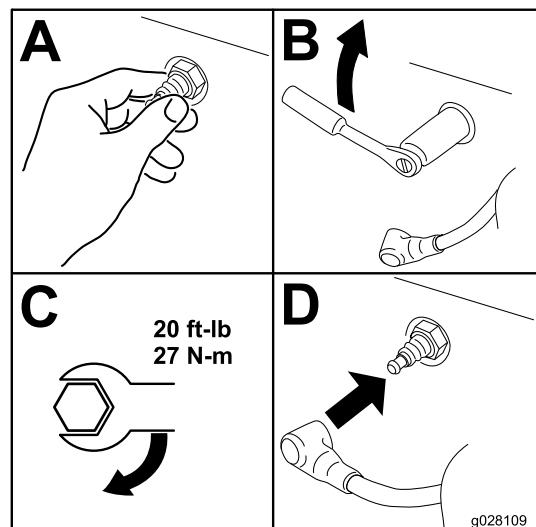

Figure 42

g028109

Cleaning the Blower Housing

Service Interval: Every 100 hours/Yearly (whichever comes first)

To ensure proper cooling, ensure that the grass screen, cooling fins, and other external surfaces of the engine are kept clean at all times.

Clean the cooling fins and external surfaces as necessary. Make sure that the cooling shrouds are installed. Torque the blower housing screws to 7.5 N·m (5.5 ft-lb).

Important: Operating the engine with a blocked grass screen, dirty or plugged cooling fins, and/or cooling shrouds removed, causes engine damage due to overheating.

Fuel System Maintenance

⚠ DANGER

In certain conditions, fuel is extremely flammable and highly explosive. A fire or explosion from fuel can burn you and others and can damage property.

Refer to [Fuel Safety \(page 15\)](#) for a complete list of fuel related precautions.

Replacing the In-Line Fuel Filter

Service Interval: Every 100 hours—Replace the in-line fuel filter.

Never install a dirty filter after removing it from the fuel line.

1. Park the machine on a level surface, disengage the blade-control switch, and engage the parking brake.
2. Shut off the engine, remove the key, and wait for all moving parts to stop before leaving the operating position. Allow the engine to cool.
3. Replace the filter ([Figure 43](#)).

Note: Ensure that the flow-direction arrow on the replacement filter points toward the engine.

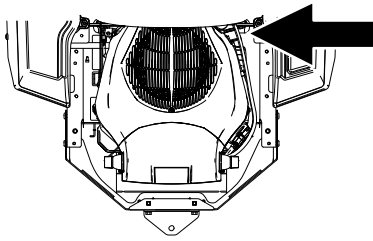

Electrical System Maintenance

Electrical System Safety

- Disconnect the cable from the negative terminal of the battery before repairing the machine.
- Charge the battery in an open, well-ventilated area, away from sparks and flames. Unplug the charger before connecting or disconnecting the battery. Wear protective clothing and use insulated tools.

g305646

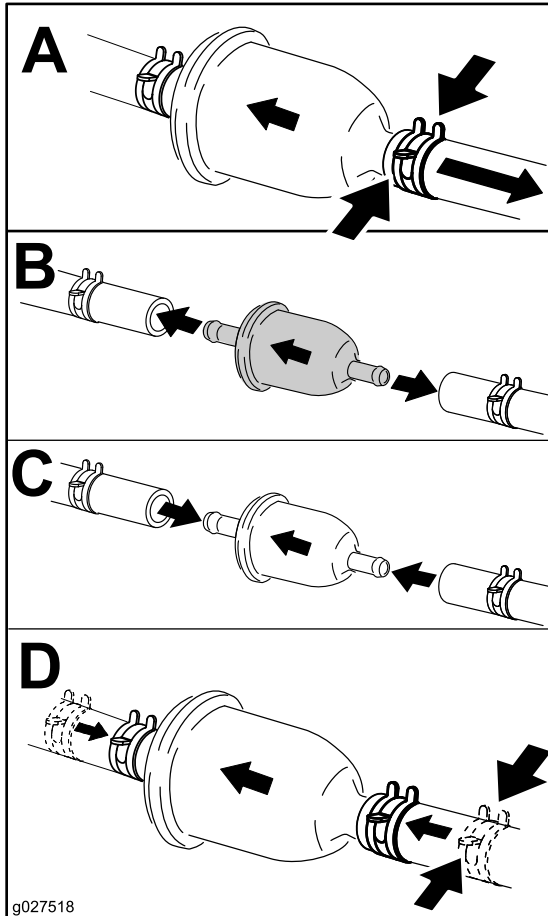

g027518

g027518

Figure 43

Servicing the Battery

Removing the Battery

⚠ WARNING

Incorrectly removing the cables from battery could damage the machine and cables, causing sparks. Sparks can cause the battery gasses to explode, resulting in personal injury.

- Always disconnect the negative (black) battery cable before disconnecting the positive (red) cable.
 - Always connect the positive (red) battery cable before connecting the negative (black) cable.
1. Park the machine on a level surface, disengage the blade-control switch (PTO), and engage the parking brake.
 2. Shut off the engine, remove the key, and wait for all moving parts to stop before leaving the operating position.
 3. Loosen the 2 fasteners on the battery cover counterclockwise 1/4 turn, and remove the battery cover ([Figure 44](#)).

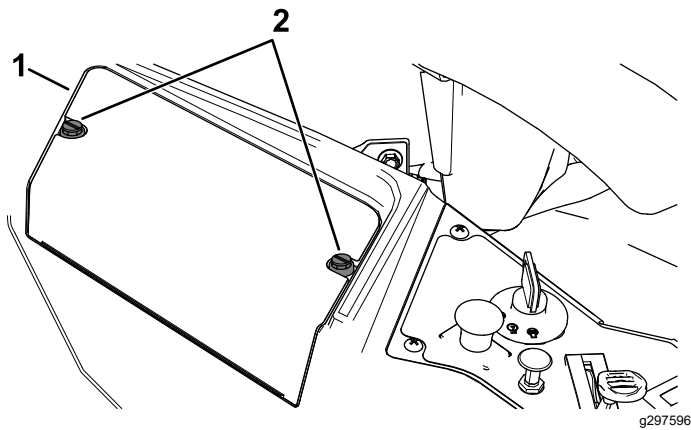

Figure 44

- 1. Battery cover
- 2. Fasteners

- 4. Disconnect the negative (black) ground cable from the battery post (Figure 45).

Note: Retain all fasteners.

- 5. Slide the rubber cover up the positive (red) cable.

- 6. Disconnect the positive (red) cable from the battery post (Figure 45).

Note: Retain all fasteners.

- 7. Remove the battery hold-down (Figure 45), and lift the battery from the battery tray.

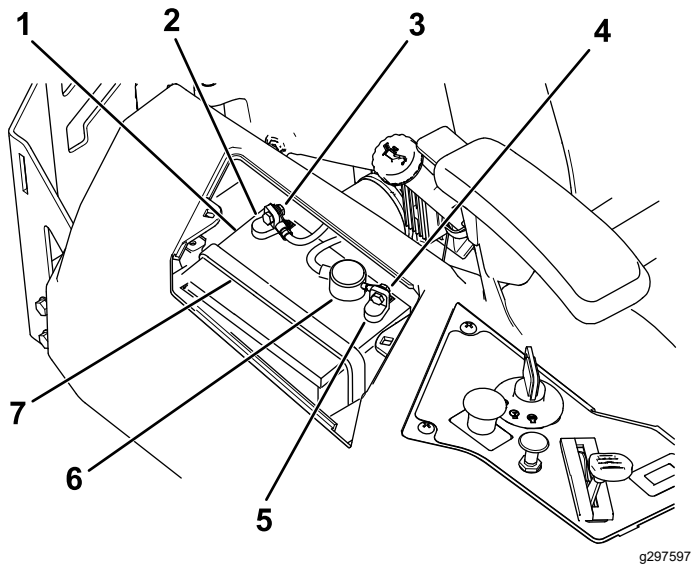

Figure 45

- 1. Battery
- 2. Negative (-) battery post
- 3. Bolt, washer, and nut for the negative (-) battery post
- 4. Bolt, washer, and nut for the positive (+) battery post
- 5. Positive (+) battery post
- 6. Terminal boot
- 7. Battery hold-down

Charging the Battery

Service Interval: Before storage—Charge the battery and disconnect the battery cables.

1. Remove the battery from the chassis; refer to [Removing the Battery](#) (page 37).
2. Charge the battery for a minimum of 1 hour at 6 to 10 A.

Note: Do not overcharge the battery.

3. When the battery is fully charged, unplug the charger from the electrical outlet, then disconnect the charger leads from the battery posts (Figure 46).

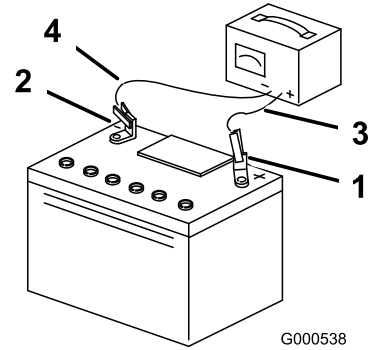

Figure 46

- 1. Positive (+) battery post
- 2. Negative (-) battery post
- 3. Red (+) charger lead
- 4. Black (-) charger lead

Installing the Battery

1. Position the battery in the tray (Figure 45).
2. Using the fasteners previously removed, install the positive (red) battery cable to the positive (+) battery terminal.
3. Using the fasteners previously removed, install the negative battery cable to the negative (-) battery terminal.
4. Slide the red terminal boot onto the positive (red) battery post.
5. Secure the battery with the hold-down (Figure 45).
6. Install the battery cover by pushing down and tightening the 2 fasteners clockwise (Figure 44).

Servicing the Fuses

The electrical system is protected by fuses. It requires no maintenance; however, if a fuse blows, check the component/circuit for a malfunction or short.

Fuse type:

- Main—F1 (15 A, blade-type)
- Charge Circuit—F2 (25 A, blade-type)

To replace the Main (15 A) fuse, reach into the opening in the side of the console, pull out the fuse, and install a new 15 A fuse (Figure 47).

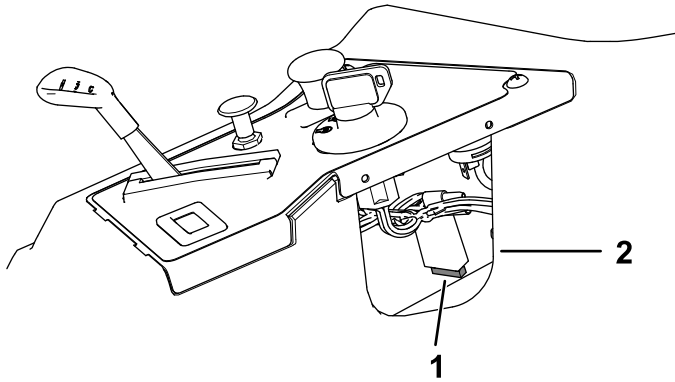

Figure 47

g297599

1. Main (15 A)
2. Console opening

To replace the Charge Circuit (25 A) fuse, locate the fuse to the left of battery, pull out the fuse, and install a new 25 A fuse (Figure 48).

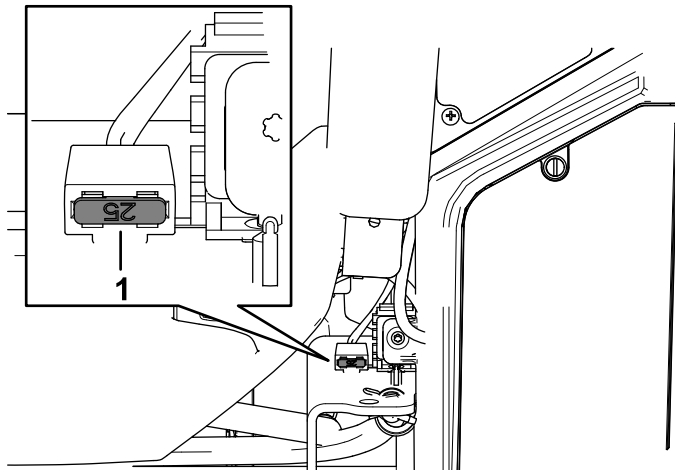

Figure 48

g297598

1. Charge circuit (25 A)

Drive System Maintenance

Checking the Tire Pressure

Service Interval: Every 25 hours—Check tire pressure.

Maintain the air pressure in the front and rear tires as specified. Uneven tire pressure can cause uneven cut. Check the pressure at the valve stem (Figure 49). Check the tires when they are cold to get the most accurate pressure reading.

Inflate the front caster wheel tires to 103 kPa (15 psi).

Inflate the rear drive wheel tires to 90 kPa (13 psi).

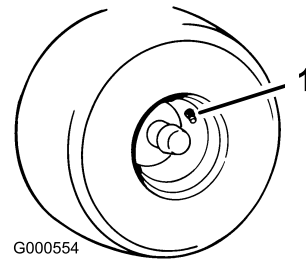

G000554

Figure 49

g000554

1. Valve stem

Belt Maintenance

Inspecting the Belts

Service Interval: Every 25 hours—Check the belts for wear or cracks.

Replace the belt if it is worn. The signs of a worn belt include squealing while the belt is rotating; the blades slipping while cutting grass; and frayed edges, burn marks, and cracks on the belt.

Replacing the Mower Belt

The signs of a worn belt include squealing while the belt is rotating, blades slipping while cutting grass, and frayed edges, burn marks, and cracks on the belt. Replace the mower belt if any of these conditions are evident.

1. Park the machine on a level surface, disengage the blade-control switch (PTO), and engage the parking brake.
2. Shut off the engine, remove the key, and wait for all moving parts to stop before leaving the operating position.
3. Set the height of cut at the lowest cutting position.
4. Remove the pulley covers (Figure 50).

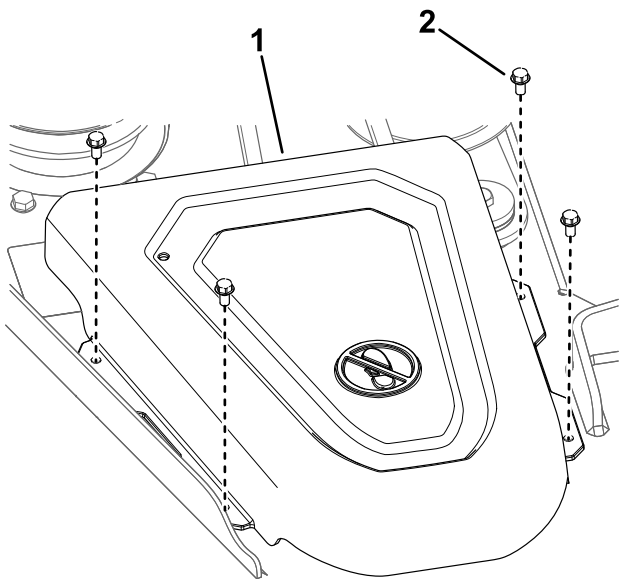

Figure 50

g297435

1. Cover
2. Screw

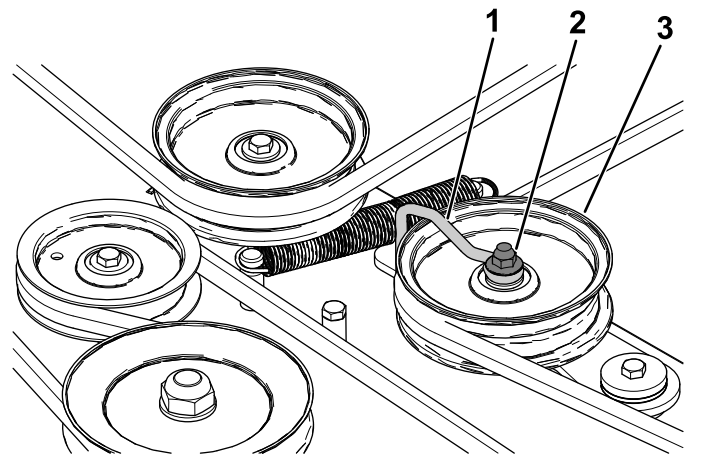

Figure 51

g334161

1. Wire form
2. Nut
3. Idler pulley

6. Using a spring-removal tool (Toro Part No. 92-5771), remove the idler spring from the deck hook to remove tension on the idler pulley and roll the belt off the pulleys (Figure 52).

⚠ WARNING

The spring is under tension when installed and can cause personal injury.

Be careful when removing the belt.

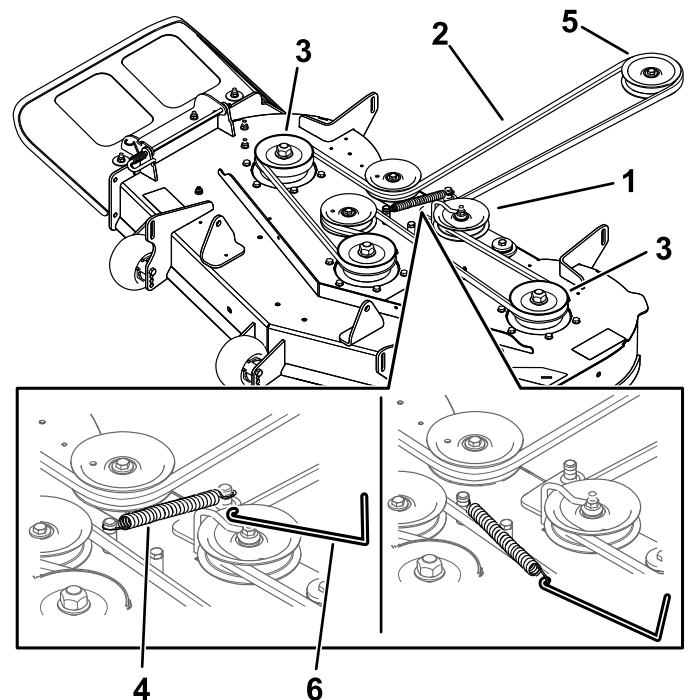

Figure 52

g297456

5. Loosen the nut securing the wire form to the idler pulley (Figure 51).
1. Idler pulley
2. Mower belt
3. Outside pulley
4. Spring
5. Engine pulley
6. Spring-removal tool

Mower Maintenance

Blade Safety

- Inspect the blades periodically for wear or damage.
- Use care when checking the blades. Wrap the blades or wear gloves, and use caution when servicing the blades. Only replace or sharpen the blades; never straighten or weld them.
- On multi-bladed machines, take care as rotating one blade can cause other blades to rotate.
- Replace worn or damaged blades and bolts in sets to preserve balance.

Servicing the Cutting Blades

To ensure a superior quality of cut, keep the blades sharp. For convenient sharpening and replacement, keep extra blades on hand.

Before Inspecting or Servicing the Blades

1. Park the machine on a level surface, disengage the blade-control switch (PTO), and engage the parking brake.
2. Shut off the engine, remove the key, and disconnect the spark-plug wires from the spark plugs.

Inspecting the Blades

Service Interval: Before each use or daily

1. Inspect the cutting edges (Figure 53).
2. If the edges are not sharp or have nicks, remove and sharpen the blade; refer to [Sharpening the Blades \(page 43\)](#).
3. Inspect the blades, especially in the curved area.
4. If you notice any cracks, wear, or a slot forming in this area, immediately install a new blade (Figure 53).

7. Route the new belt around the engine pulley and mower pulleys (Figure 52).
8. Using a spring-removal tool (Toro Part No. 92-5771), install the idler spring over the deck hook and place tension on the idler pulley and the mower belt (Figure 52).
9. Tighten the nut securing the wire form to the idler pulley (Figure 51).
Note: Position the wire form against the idler arm as shown in Figure 51.
10. Install the pulley covers.

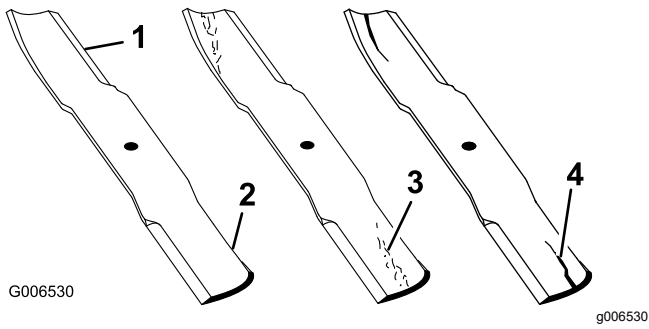

Figure 53

- | | |
|-----------------|----------------------|
| 1. Cutting edge | 3. Wear/slot forming |
| 2. Curved area | 4. Crack |

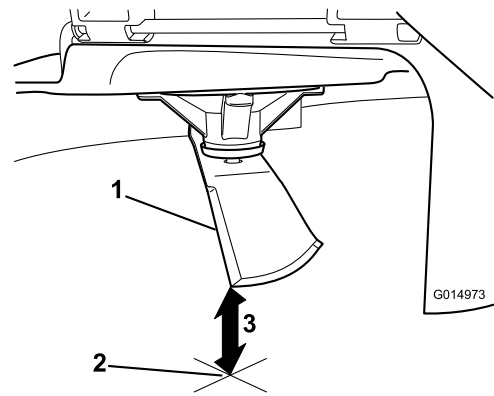

Figure 55

- | |
|--|
| 1. Blade (in position for measuring) |
| 2. Level surface |
| 3. Measured distance between blade and the surface (A) |

Checking for Bent Blades

Note: The machine must be on a level surface for the following procedure.

1. Raise the mower deck to the highest height-of-cut position.
2. While wearing thickly padded gloves, or other adequate hand protection, slowly rotate the blade into a position that allows you to measure the distance between the cutting edge and the level surface the machine is on (Figure 54).

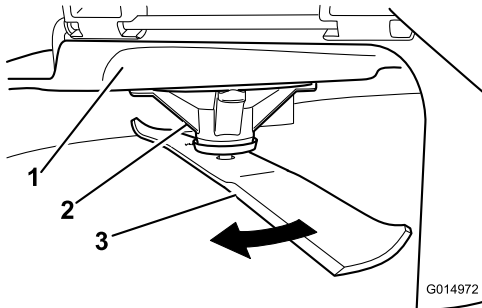

Figure 54

- | | |
|--------------------|----------|
| 1. Deck | 3. Blade |
| 2. Spindle housing | |

3. Measure from the tip of the blade to the flat surface (Figure 55).

4. Rotate the same blade 180 degrees so that the opposing cutting edge is now in the same position (Figure 56).

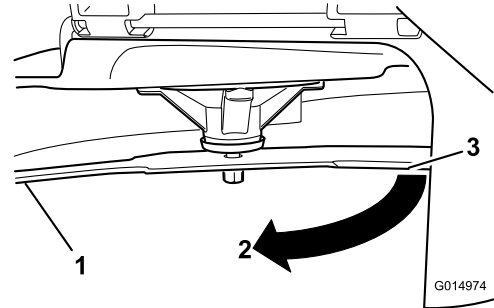

Figure 56

- | |
|---|
| 1. Blade (side previously measured) |
| 2. Measurement (position used previously) |
| 3. Opposing side of blade being moved into measurement position |

5. Measure from the tip of the blade to the flat surface (Figure 57).

Note: The variance should be no more than 3 mm (1/8 inch).

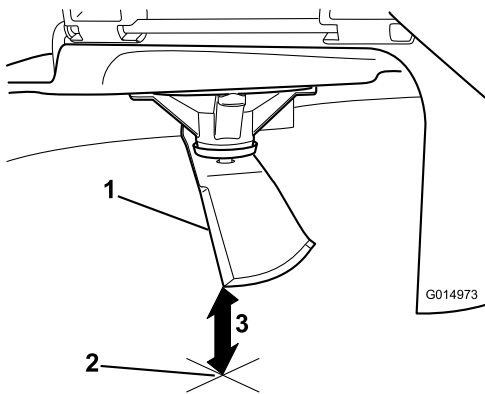

Figure 57

1. Opposite blade edge (in position for measuring)
2. Level surface
3. Second measured distance between blade and surface (B)

A. If the difference between A and B is greater than 3 mm (1/8 inch), replace the blade with a new blade; refer to [Removing the Blades \(page 43\)](#) and [Installing the Blades \(page 44\)](#).

Note: If a bent blade is replaced with a new blade, and the dimension obtained continues to exceed 3 mm (1/8 inch), the blade spindle could be bent. Contact an Authorized Service Dealer for service.

B. If the variance is within constraints, move to the next blade.

6. Repeat this procedure on each blade.

Removing the Blades

Replace the blades if they hit a solid object, or if the blade is out of balance or bent.

1. Hold the blade end using a rag or thickly padded glove.
2. Remove the blade bolt, curved washer, and blade from the spindle shaft ([Figure 58](#)).

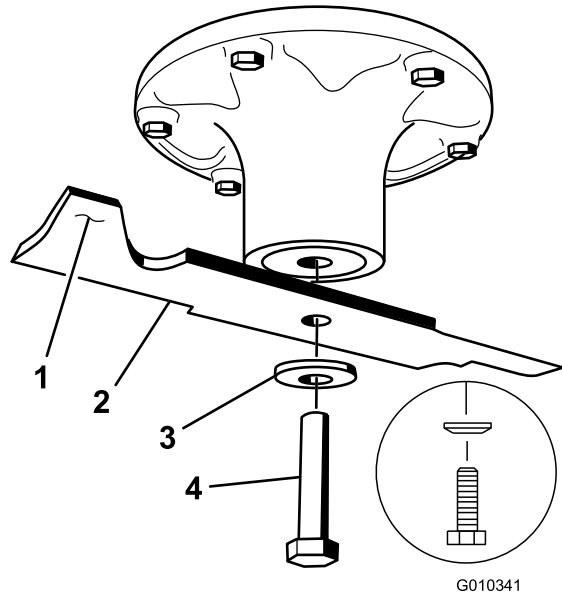

Figure 58

1. Sail area of the blade
2. Blade
3. Curved washer
4. Blade bolt

Sharpening the Blades

1. Use a file to sharpen the cutting edge at both ends of the blade ([Figure 59](#)).

Note: Maintain the original angle.

Note: The blade retains its balance if the same amount of material is removed from both cutting edges.

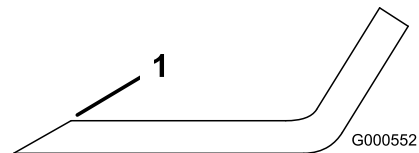

Figure 59

1. Sharpen at original angle.
2. Check the balance of the blade by putting it on a blade balancer ([Figure 60](#)).

Note: If the blade stays in a horizontal position, the blade is balanced and can be used.

Note: If the blade is not balanced, file some metal off the end of the sail area only ([Figure 59](#)).

Checking the Front-to-Rear Blade Slope

Check the front-to-rear blade level any time you install the mower. If the front of the mower is more than 7.9 mm (5/16 inch) lower than the rear of the mower, adjust the blade level.

1. Park the machine on a level surface, disengage the blade-control switch (PTO), and engage the parking brake.
2. Shut off the engine, remove the key, and wait for all moving parts to stop before leaving the operating position.
3. Set the height of cut to 76 mm (3 inches).
4. Carefully rotate the blades so they are facing front to rear (Figure 63).
5. Measure from the tip of the front blade to the flat surface and the tip of the rear blade to the flat surface (Figure 63).

Note: If the front blade tip is not 1.6 to 7.9 mm (1/16 to 5/16 inch) lower than the rear blade tip, continue to the [Leveling the Mower Deck](#) (page 45) procedure.

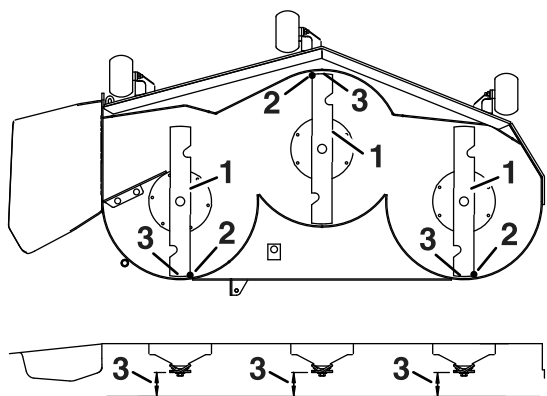

Figure 63

g229304

1. Blades front to rear
2. Outside cutting edges
3. Measure from the tip of the blade to the flat surface here.

Leveling the Mower Deck

1. Set the anti-scalp rollers to the top holes or remove them completely for this procedure; refer to [Adjusting the Anti-Scalp Rollers](#) (page 26).
2. Set the height-of-cut lever to the 76 mm (3 inch) position; refer to [Adjusting the Height of Cut](#) (page 25).
3. Place 2 blocks, each having a thickness of 6.6 cm (2-5/8 inches), under each side of the front edge of the deck but not under the anti-scalp roller brackets (Figure 64).
4. Place 2 blocks, each having a thickness of 7.3 cm (2-7/8 inches), under the rear edge of the cutting deck skirt, 1 on each side of the cutting deck (Figure 64).

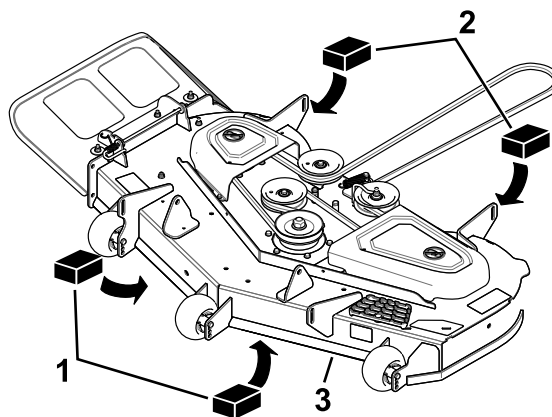

Figure 64

g297501

1. Wood block—6.6 cm (2-5/8 inches) thick
 2. Wood block—7.3 cm (2-7/8 inches) thick
 3. Front edge
5. Loosen the adjustment bolts on all 4 corners so that the deck is sitting securely on all 4 blocks (Figure 65).

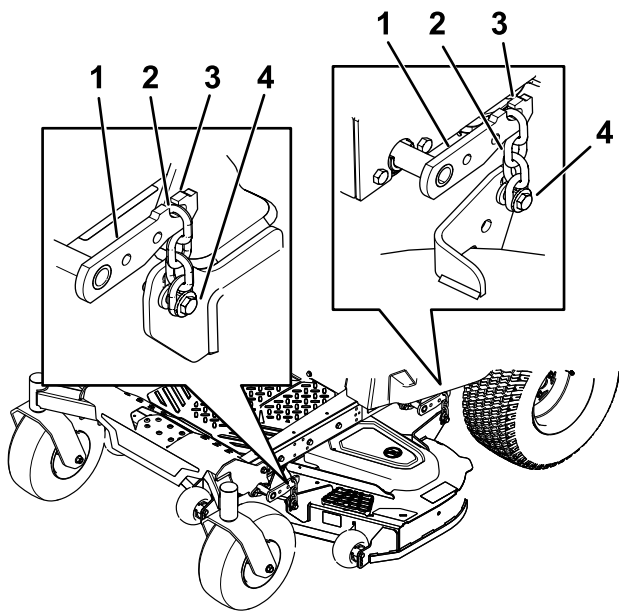

Figure 65

g297515

- | | |
|------------------|--------------------|
| 1. Deck-lift arm | 3. Hook |
| 2. Chain | 4. Adjustment bolt |

6. Ensure that there is tension on all 4 chains ([Figure 65](#)).
7. Tighten the 4 adjustment bolts ([Figure 65](#)).
8. Ensure that the blocks fit snugly under the deck skirt and that all bolts are tight.
9. Verify that the deck is level by checking the side-to-side level and front-to-rear blade slope; repeat the deck leveling procedure if necessary.

Removing the Mower Deck

1. Park the machine on a level surface, disengage the blade-control switch (PTO), and engage the parking brake.
2. Shut off the engine, remove the key, and disconnect the spark-plug wires from the spark plugs.
3. Lower the mower to the 76 mm (3 inches) height-of-cut position.
4. Remove the mower belt from the engine pulley; refer to [Replacing the Mower Belt \(page 40\)](#).
5. Remove the hairpin cotter and washer securing the link pin to the frame and deck, and remove the link bar ([Figure 66](#)).

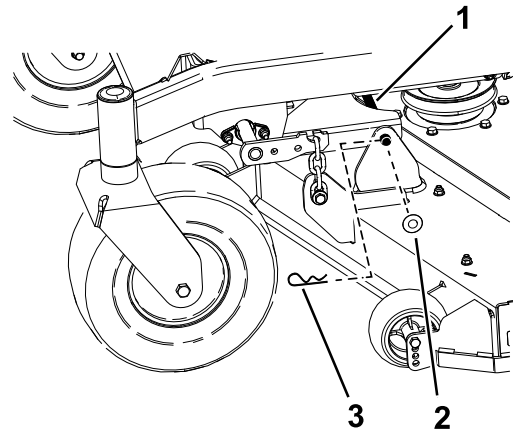

Figure 66

g297517

- | | |
|-------------|-------------------|
| 1. Link pin | 3. Hairpin cotter |
| 2. Washer | |

6. Lift up the mower deck to relieve tension from the mower deck.
7. Remove the chains from the hooks on the deck-lift arms ([Figure 67](#)).

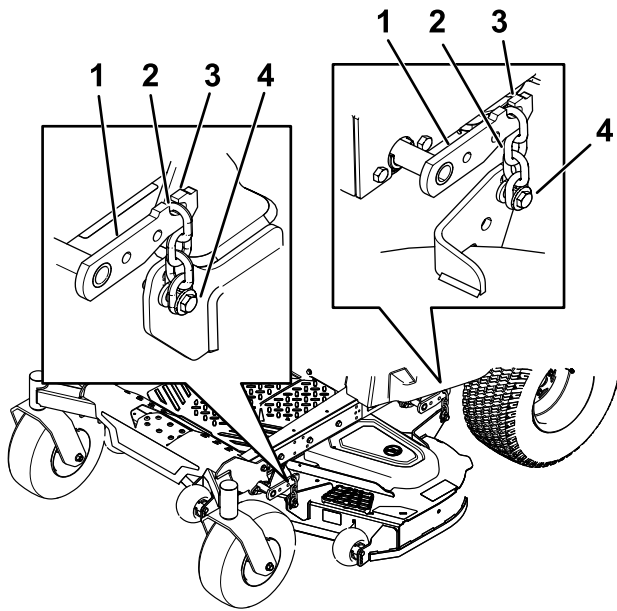

Figure 67

g297515

- | | |
|------------------|--------------------|
| 1. Deck-lift arm | 3. Hook |
| 2. Chain | 4. Adjustment bolt |

Replacing the Grass Deflector

Service Interval: Before each use or daily—Inspect the grass deflector for damage.

⚠ WARNING

An uncovered discharge opening could allow the machine to throw objects toward you or bystanders, resulting in serious injury. Also, contact with the blade could occur.

Never operate the machine unless you install a mulch plate, discharge deflector, or grass collection system.

1. Disengage the spring from the notch in the deflector bracket and slide the rod out of the welded deck brackets, spring, and discharge deflector (Figure 68).

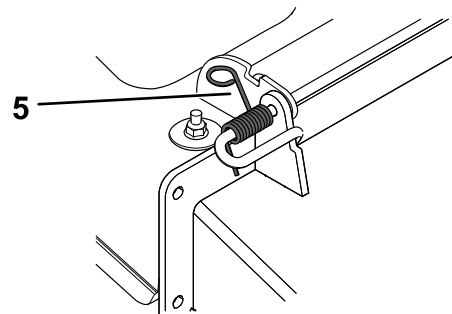
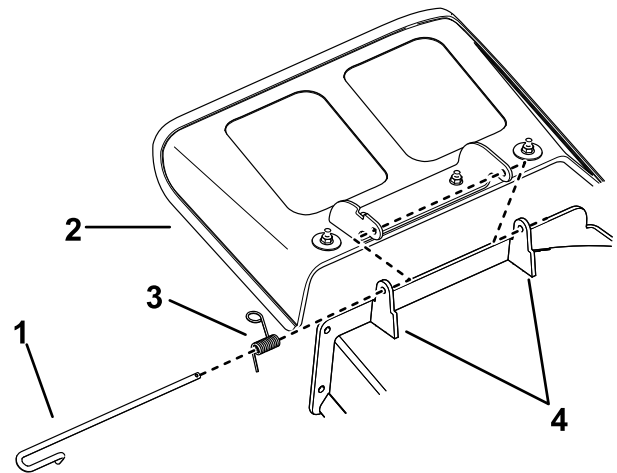

Figure 68

g297555

- | | |
|--------------|----------------------------------|
| 1. Rod | 4. Deck brackets |
| 2. Spring | 5. Spring installed over the rod |
| 3. Deflector | |

2. Remove the damaged or worn discharge deflector.

8. Raise the height of cut to the transport position.
9. Remove the belt from the clutch pulley on the engine.
10. Slide the mower out from underneath the machine.

Note: Retain all parts for future installation.

Installing the Mower Deck

1. Park the machine on a level surface, disengage the blade-control switch (PTO), and engage the parking brake.
2. Shut off the engine, remove the key, and disconnect the spark-plug wires from the spark plugs.
3. Slide the mower under the machine.
4. Lower the height-of-cut lever to the lowest position.
5. Place the height-of-cut pin in the lock position for lowest height of cut.
6. Lift the rear of the mower deck and attach the chains to the rear lift arms (Figure 67).
7. Attach the front chains to the front lift arms (Figure 67).
8. Install the long link bar through the frame hanger and deck.
9. Secure the link pin with the hairpin cotters and washers removed previously (Figure 66).
10. Install the mower belt onto the engine pulley; refer to Replacing the Mower Belt (page 40).

3. Position the new discharge deflector with the bracket ends between the welded brackets on the deck as shown in [Figure 69](#).
4. Install the spring onto the straight end of the rod.
5. Position the spring on the rod as shown in [Figure 69](#) so that the shorter spring end comes from under the rod before the bend and going over the rod as it returns from the bend.
6. Lift the loop end of the spring and place it into the notch on the deflector bracket ([Figure 69](#)).

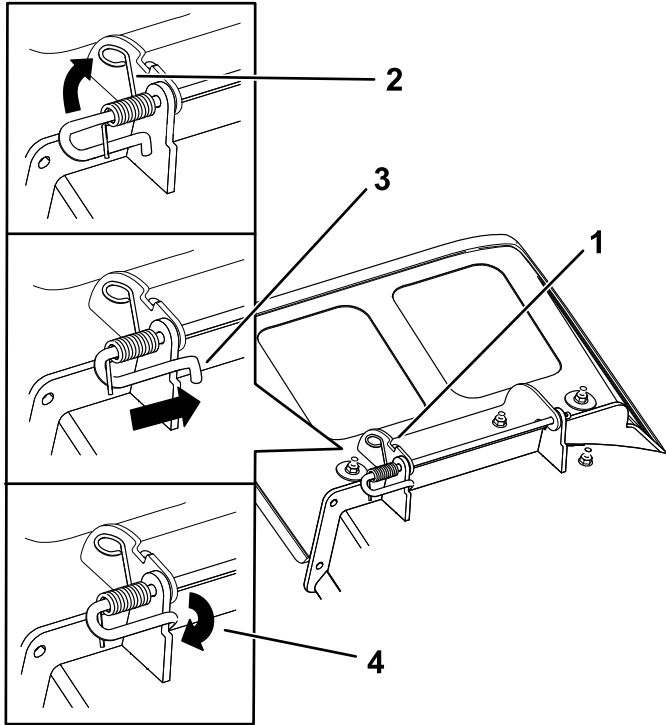

Figure 69

g297573

- | | |
|---|---|
| 1. Rod and spring assembly installed | 3. Rod, short end, moved behind the mower bracket |
| 2. Loop end of the spring installed into the notch in the deflector bracket | 4. Short end, retained by mower bracket. |

7. Secure the rod and spring assembly by twisting it so that the short end of the rod is behind the front bracket welded to the deck ([Figure 69](#)).

Important: The grass deflector must be spring loaded in the down position. Lift the deflector up to test that it snaps to the full down position.

Cleaning

Disposing of Waste

Engine oil, batteries, hydraulic fluid, and engine coolant are pollutants to the environment. Dispose of these according to your state and local regulations.

Storage

Storage Safety

- Shut off the engine, remove the key, and wait for all moving parts to stop before you leave the operator's position. Allow the machine to cool before adjusting, servicing, cleaning, or storing it.
- Do not store the machine or fuel near flames or drain the fuel indoors or inside an enclosed trailer.
- Do not store the machine or fuel container where there is an open flame, spark, or pilot light, such as on a water heater or on other appliances.

Cleaning and Storage

1. Disengage the blade-control switch (PTO), and engage the parking brake.
2. Shut off the engine, remove the key, and wait for all moving parts to stop before leaving the operating position.
3. Remove grass clippings, dirt, and grime from the external parts of the entire machine, especially the engine and hydraulic system. Clean dirt and chaff from the outside of the engine cylinder head fins and blower housing.

Important: You can wash the machine with mild detergent and water. Do not pressure-wash the machine. Avoid excessive use of water, especially near the control panel, engine, hydraulic pumps, and motors.

4. Check the parking brake operation; refer to [Operating the Parking Brake \(page 21\)](#).
5. Service the air cleaner; refer to [Servicing the Air Cleaner \(page 32\)](#).
6. Change the crankcase oil; refer to [Servicing the Engine Oil \(page 33\)](#).
7. Check the tire pressure; refer to [Checking the Tire Pressure \(page 39\)](#).
8. Charge the battery; refer to [Charging the Battery \(page 38\)](#).
9. If storing the machine with the battery installed, disconnect the negative (black) cable from the battery.
10. Scrape any heavy buildup of grass and dirt from the underside of the mower, then wash the machine with a garden hose.

Note: Run the machine with the blade-control switch (PTO) engaged and the engine at high idle for 2 to 5 minutes after washing.

11. Check the condition of the blades; refer to [Servicing the Cutting Blades \(page 41\)](#).
 12. Prepare the machine for storage when non-use occurs over 30 days. Prepare the machine for storage as follows:
 - A. Add fuel stabilizer/conditioner to fresh fuel in the tank. Follow mixing instructions from the fuel stabilizer manufacturer. Do not use an alcohol-based stabilizer (ethanol or methanol).
 - B. Run the engine to distribute conditioned fuel through the fuel system for 5 minutes.
 - C. Shut off the engine, allow it to cool, and drain the fuel tank.
 - D. Start the engine and run it until it shuts off.
 - E. Dispose of fuel properly. Recycle the fuel according to local codes.
- Important:** Do not store fuel containing stabilizer/conditioner longer than the duration recommended by the fuel-stabilizer manufacturer.
13. Remove and check the condition of the spark plug(s); refer to [Servicing the Spark Plug \(page 35\)](#). With the spark plug(s) removed from the engine, pour 30 ml (2 tablespoons) of engine oil into the spark plug hole. Use the starter to crank the engine and distribute the oil inside the cylinder. Install the spark plug(s). Do not install the wire on the spark plug(s).
 14. Check and tighten all bolts, nuts, and screws. Repair or replace any part that is damaged.
 15. Paint all scratched or bare metal surfaces. Paint is available from your Authorized Service Dealer.
 16. Store the machine in a clean, dry garage or storage area. Remove the key from the switch and keep it out of reach of children or other unauthorized users. Cover the machine to protect it and keep it clean.

Storing the Battery

1. Fully charge the battery.
2. Let the battery rest for 24 hours, then check the battery voltage.
Note: If the battery voltage is below 12.6 V, repeat steps 1 and 2.
3. Disconnect the cables from the battery.
4. Check the voltage periodically to ensure that the voltage is 12.4 V or higher.

Note: If the battery voltage is below 12.4 V, repeat steps 1 and 2.

Battery Storage Tips

If you are storing the battery outside the machine, do the following:

- Store the battery in a cool, dry area in an upright position.
- Do not stack batteries directly on top of each other, unless they are in cartons.
- Do not stack more than 3 batteries (only 2 if the battery type is commercial).
- Test a wet battery every 4 to 6 months and charge it, if necessary.
- Always test and charge the battery before installation.

Troubleshooting

Problem	Possible Cause	Corrective Action
The fuel tank is showing signs of collapsing or the machine is frequently showing signs of running out of fuel.	1. The air-cleaner paper element clogged.	1. Clean the paper element.
The engine overheats.	<ol style="list-style-type: none"> 1. The engine load is excessive. 2. The oil level in the crankcase is low. 3. The cooling fins and air passages under the engine-blower housing are plugged. 4. The air cleaner is dirty. 5. Dirt, water, or stale fuel is in the fuel system. 	<ol style="list-style-type: none"> 1. Reduce the ground speed. 2. Add oil to the crankcase. 3. Remove the obstruction from the cooling fins and air passages. 4. Clean or replace the air-cleaner element. 5. Contact an Authorized Service Dealer
The starter does not crank.	<ol style="list-style-type: none"> 1. The blade-control switch is engaged. 2. The motion-control levers are not in the NEUTRAL-LOCK position. 3. The battery is dead. 4. The electrical connections are corroded or loose. 5. A fuse is blown. 6. A relay or switch is damaged. 	<ol style="list-style-type: none"> 1. Disengage the blade-control switch. 2. Move the motion-control levers outward to the NEUTRAL-LOCK position. 3. Charge the battery. 4. Check the electrical connections for good contact. 5. Replace the fuse. 6. Contact an Authorized Service Dealer.
The engine does not start, starts hard, or fails to keep running.	<ol style="list-style-type: none"> 1. The fuel tank is empty. 2. The choke (if applicable) is not on. 3. The air cleaner is dirty. 4. The spark-plug wire(s) is loose or disconnected. 5. The spark plug(s) is pitted, fouled, or the gap is incorrect. 6. There is dirt in fuel filter. 7. Dirt, water, or stale fuel is in fuel system. 8. There is incorrect fuel in the fuel tank. 9. The oil level in the crankcase is low. 	<ol style="list-style-type: none"> 1. Fill the fuel tank. 2. Move the choke lever to the ON position. 3. Clean or replace the air-cleaner element. 4. Install the wire(s) on the spark plug. 5. Install a new, correctly gapped spark plug(s). 6. Replace the fuel filter. 7. Contact an Authorized Service Dealer. 8. Drain the tank and replace the fuel with the proper type or contact an authorized service dealer. 9. Add oil to the crankcase.
The engine loses power.	<ol style="list-style-type: none"> 1. The engine load is excessive. 2. The air cleaner is dirty. 3. The oil level in the crankcase is low. 4. The cooling fins and air passages under the engine blower housing are plugged. 5. The spark plug(s) is pitted, fouled, or the gap is incorrect. 6. The fuel-tank vent is blocked. 7. There is dirt in the fuel filter. 8. Dirt, water, or stale fuel is in the fuel system. 9. There is incorrect fuel in the fuel tank. 	<ol style="list-style-type: none"> 1. Reduce the ground speed. 2. Clean the air-cleaner element. 3. Add oil to the crankcase. 4. Remove the obstruction from the cooling fins and air passages. 5. Install a new, correctly gapped spark plug(s). 6. Contact an Authorized Service Dealer. 7. Replace the fuel filter. 8. Contact an Authorized Service Dealer. 9. Drain the tank and replace the fuel with the proper type or contact an authorized service dealer.

Problem	Possible Cause	Corrective Action
The machine does not drive.	<ol style="list-style-type: none"> 1. The bypass valves are open. 2. The traction belts are worn, loose, or broken. 3. The traction belts are off the pulleys. 4. The transmission has failed. 	<ol style="list-style-type: none"> 1. Close the tow valves. 2. Contact an Authorized Service Dealer. 3. Contact an Authorized Service Dealer. 4. Contact an Authorized Service Dealer.
The machine vibrates abnormally.	<ol style="list-style-type: none"> 1. The cutting blade(s) is/are bent or unbalanced. 2. The blade mounting bolt is loose. 3. The engine mounting bolts are loose. 4. The engine pulley, idler pulley, or blade pulley is loose. 5. The engine pulley is damaged. 6. The blade spindle is bent. 7. The motor mount is loose or worn. 	<ol style="list-style-type: none"> 1. Install new cutting blade(s). 2. Tighten the blade mounting bolt. 3. Tighten the engine mounting bolts. 4. Tighten the appropriate pulley. 5. Contact an Authorized Service Dealer. 6. Contact an Authorized Service Dealer. 7. Contact an Authorized Service Dealer.
The cutting height is uneven.	<ol style="list-style-type: none"> 1. The blade(s) is not sharp. 2. A cutting blade(s) is/are bent. 3. The mower is not level. 4. An anti-scalp roller (if applicable) is not set correctly. 5. The underside of the mower deck is dirty. 6. The tire pressure is incorrect. 7. A blade spindle is bent. 	<ol style="list-style-type: none"> 1. Sharpen the blade(s). 2. Install a new cutting blade(s). 3. Level the mower from side-to-side and front-to-rear. 4. Adjust the anti-scalp wheel height. 5. Clean the underside of the mower deck. 6. Adjust the tire pressure. 7. Contact an Authorized Service Dealer.
The blades do not rotate.	<ol style="list-style-type: none"> 1. The drive belt is worn, loose or broken. 2. The drive belt is off of the pulley. 3. The power-takeoff (PTO) switch or PTO clutch is faulty. 4. The mower belt is worn, loose, or broken. 	<ol style="list-style-type: none"> 1. Install a new drive belt. 2. Install the drive belt and check the adjusting shafts and belt guides for the correct position. 3. Contact an Authorized Service Dealer. 4. Install a new mower belt.

Schematics

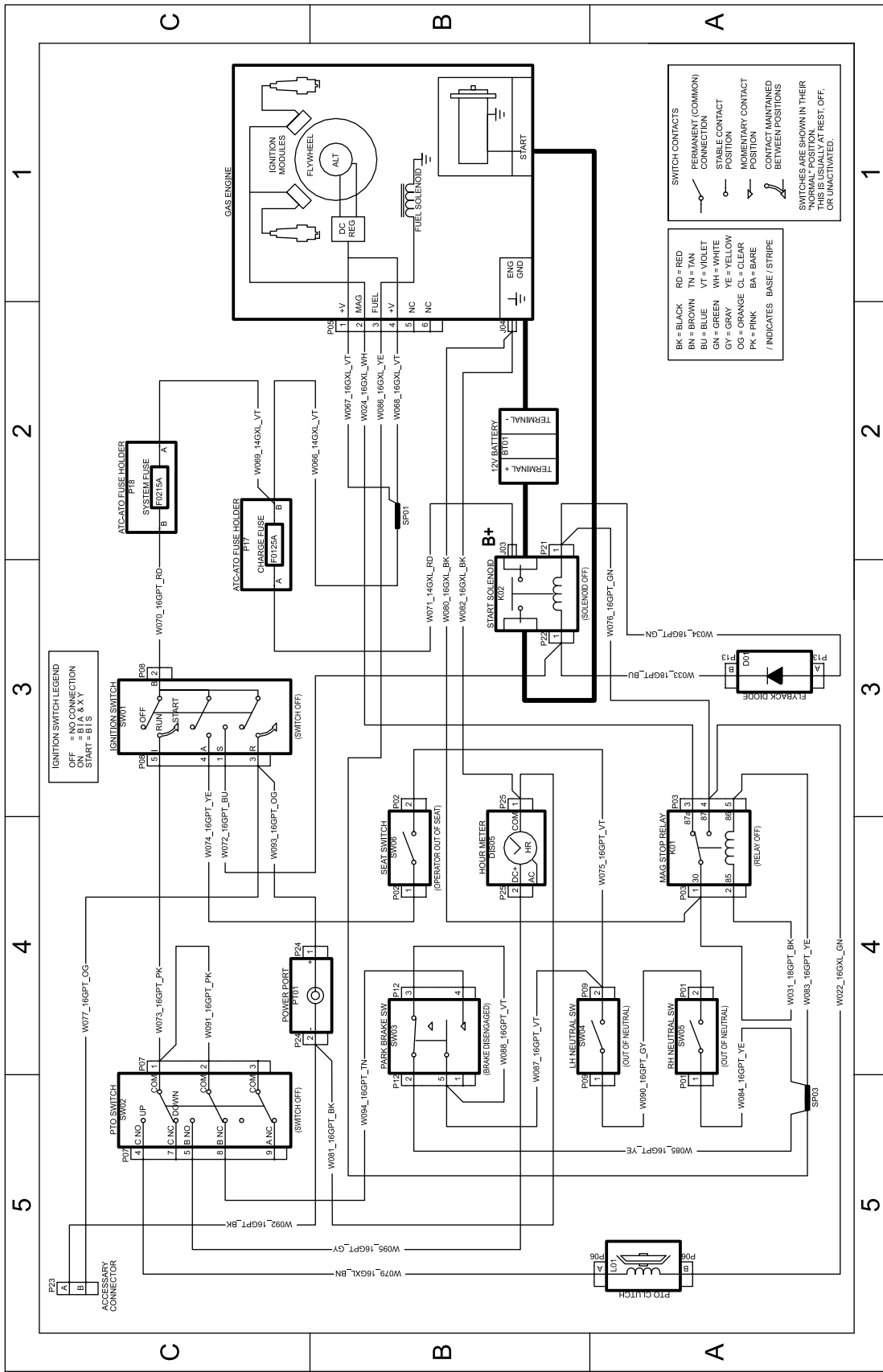

Electrical Diagram (Rev. A)

g297640

Notes:

California Proposition 65 Warning Information

What is this warning?

You may see a product for sale that has a warning label like the following:



WARNING: Cancer and Reproductive Harm—www.p65Warnings.ca.gov.

What is Prop 65?

Prop 65 applies to any company operating in California, selling products in California, or manufacturing products that may be sold in or brought into California. It mandates that the Governor of California maintain and publish a list of chemicals known to cause cancer, birth defects, and/or other reproductive harm. The list, which is updated annually, includes hundreds of chemicals found in many everyday items. The purpose of Prop 65 is to inform the public about exposure to these chemicals.

Prop 65 does not ban the sale of products containing these chemicals but instead requires warnings on any product, product packaging, or literature with the product. Moreover, a Prop 65 warning does not mean that a product is in violation of any product safety standards or requirements. In fact, the California government has clarified that a Prop 65 warning "is not the same as a regulatory decision that a product is 'safe' or 'unsafe.'" Many of these chemicals have been used in everyday products for years without documented harm. For more information, go to <https://oag.ca.gov/prop65/faqs-view-all>.

A Prop 65 warning means that a company has either (1) evaluated the exposure and has concluded that it exceeds the "no significant risk level"; or (2) has chosen to provide a warning based on its understanding about the presence of a listed chemical without attempting to evaluate the exposure.

Does this law apply everywhere?

Prop 65 warnings are required under California law only. These warnings are seen throughout California in a wide range of settings, including but not limited to restaurants, grocery stores, hotels, schools, and hospitals, and on a wide variety of products. Additionally, some online and mail order retailers provide Prop 65 warnings on their websites or in catalogs.

How do the California warnings compare to federal limits?

Prop 65 standards are often more stringent than federal and international standards. There are various substances that require a Prop 65 warning at levels that are far lower than federal action limits. For example, the Prop 65 standard for warnings for lead is 0.5 µg/day, which is well below the federal and international standards.

Why don't all similar products carry the warning?

- Products sold in California require Prop 65 labelling while similar products sold elsewhere do not.
- A company involved in a Prop 65 lawsuit reaching a settlement may be required to use Prop 65 warnings for its products, but other companies making similar products may have no such requirement.
- The enforcement of Prop 65 is inconsistent.
- Companies may elect not to provide warnings because they conclude that they are not required to do so under Prop 65; a lack of warnings for a product does not mean that the product is free of listed chemicals at similar levels.

Why does Toro include this warning?

Toro has chosen to provide consumers with as much information as possible so that they can make informed decisions about the products they buy and use. Toro provides warnings in certain cases based on its knowledge of the presence of one or more listed chemicals without evaluating the level of exposure, as not all the listed chemicals provide exposure limit requirements. While the exposure from Toro products may be negligible or well within the "no significant risk" range, out of an abundance of caution, Toro has elected to provide the Prop 65 warnings. Moreover, if Toro does not provide these warnings, it could be sued by the State of California or by private parties seeking to enforce Prop 65 and subject to substantial penalties.



Count on it.