

3325-366 Rev A



MODEL NO. 30450 210000001 & UP
MODEL NO. 30455TC 210000001 & UP

OPERATOR S
MANUAL

GROUNDMASTER[®] 455-D



Table of Contents

Table of Contents	1	Changing Bi-Directional Clutch Lubricant (Model 30455 Only)	34
Safety	2	Rear Wheel Toe In	34
Sound & Vibration Levels	4	Adjusting Service Brakes	35
		Adjusting Pro Belt	35
Symbol Glossary	5	Adjusting The Clutch	36
		Battery Care	36
Specifications	8	Fuses	36
Before Operating	10	Cutting Unit Maintenance	38
Check The Engine Oil	10	General Maintenance	38
Check The Cooling System	10	Separating The Cutting Unit From The Traction Unit	39
Fill The Fuel Tank	10	Mounting the Cutting Unit to The Traction Unit	39
Check The Hydraulic Circuit Oil	11	Safety Door Adjustment	40
Check The Front Axle Oil Level	12	Blade Adjustment	40
Check The Rear Axle Lubricant (Model 30455 Only)	13	Adjusting Belt Tension	41
Check Bi-Directional Clutch Lubricant	13	Replacing Drive Belts	41
Check Tire Pressure	14	Servicing Front Bushings In Castor Arms	43
Check The Torque Of Wheel Nuts Or Bolts	14	Servicing Castor Wheels And Bearings	43
Check The Lubricant In The Gear Box	14		
Adjusting The Height Of Cut	14	Preparation for Seasonal Storage	46
Safety Doors	16	Blade Removal And Installation	44
Controls	17	Inspecting And Sharpening The Blade	45
Operating	19		
Starting and Stopping	19		
Priming the Fuel System	19		
Checking the Interlock System	19		
Operating Characteristics	20		
Operating Tips	21		
Maintenance	22		
Minimum Recommended Maintenance Intervals	22		
Greasing	24		
General Air Cleaner Maintenance	27		
Servicing the Air Cleaner	27		
Engine Oil and Filter	28		
Fuel System	28		
Engine Cooling System	29		
Engine Timing Belt	30		
Changing Hydraulic Oil	30		
Replacing The Hydraulic Filter	31		
Checking Hydraulic Lines and Hoses	32		
Hydraulic System Test Ports	32		
Adjusting The Traction Drive For Neutral	33		
Changing Front Axle Lubricant	33		
Changing Rear Axle Lubricant (Model 30455 only)	34		

Safety

Improper use or maintenance by the operator or owner can result in injury. To reduce the potential for injury, comply with these safety instructions and always pay attention to the safety alert symbol, which means CAUTION, WARNING, or DANGER—“personal safety instruction.” Failure to comply with the instruction may result in personal injury or death.

Before Operating

1. Read and understand the contents of this manual before starting and operating the machine. Become familiar with the controls and know how to stop the machine and engine quickly.

A free replacement manual is available by sending the complete model and serial number to:

The Toro Company
8111 Lyndale Avenue South
Minneapolis, Minnesota 55420.

2. Never allow children to operate the machine. Do not allow adults to operate machine without proper instruction. Only trained operators who have read this manual should operate this machine.
3. Never operate the machine when under the influence of drugs or alcohol.
4. Keep all shields, safety devices and decals in place. If a shield, safety device or decal is defective, illegible or damaged, repair or replace it before operating the machine. Also tighten any loose nuts, bolts or screws to ensure machine is in safe operating condition.
5. Always wear substantial shoes. Do not operate machine while wearing sandals, tennis shoes, sneakers or when barefoot. Do not wear loose fitting clothing that could get caught in moving parts and possibly cause personal injury. Wearing safety glasses, safety shoes, long pants and a helmet is advisable and required by some local ordinances and insurance regulations.
6. Assure interlock switches are adjusted correctly so engine cannot be started unless traction pedal is in NEUTRAL and cutting unit is DISENGAGED.
7. Remove all debris or other objects that might be picked up and thrown by the blades or fast moving

components from other attached implements. Keep all bystanders away from operating area.

8. Since diesel fuel is highly flammable, handle it carefully:
 - A. Use an approved fuel container.
 - B. Do not remove fuel tank cap while engine is hot or running.
 - C. Do not smoke while handling fuel.
 - D. Fill fuel tank outdoors and only to within an inch from the top of the tank, not the filler neck. Do not overfill.
 - E. Wipe up any spilled fuel.

While Operating

9. Sit on the seat when starting and operating the machine.
10. Before starting the engine:
 - A. Engage the parking brake.
 - B. Make sure traction pedal is in NEUTRAL and cutting decks are DISENGAGED. Move axle shift to HI or LO position.
 - C. After engine is started, release parking brake and keep foot off traction pedal. Machine must not move. If movement is evident, the neutral return mechanism is adjusted incorrectly; therefore, shut engine off and adjust until machine does not move when traction pedal is released. Refer to *Adjusting Traction Drive for Neutral*, page ???.
11. Seating capacity is one person. Therefore, never carry passengers.
12. Do not run engine in a confined area without adequate ventilation. Exhaust fumes are hazardous and could possibly be deadly.
13. Check interlock switches daily for proper operation. Do not rely entirely on safety switches—use common sense. If a switch fails, replace it before operating the machine. The interlock system is for your protection, so do not bypass it. Replace all interlock switches every two years.
14. Using the machine demands attention and to

prevent loss of control:

- A. Operate only in daylight or when there is good artificial light.
 - B. Drive slowly. Avoid sudden stops and starts.
 - C. Watch for holes or other hidden hazards.
 - D. Look behind machine before backing up.
 - E. Do not drive close to a sand trap, ditch, creek or other hazard.
 - F. Reduce speed when making sharp turns and turning on a hillside.
15. Traverse slopes carefully. Do not start or stop suddenly when traveling uphill or downhill. Never shift axle when moving. Machine must be on a flat surface and/or brakes must be engaged to prevent freewheeling.
16. Operator must be skilled and trained in how to drive on hillsides. Failure to use caution on slopes or hills may cause loss of control and vehicle to tip or roll possibly resulting in personal injury or death.
17. This product may exceed noise levels of 85 dB(A) at the operator position. Ear protectors are recommended, for prolonged exposure, to reduce the potential of permanent hearing damage.
18. When operating 4-wheel drive machine, always use the seat belt and roll-over protection system together and have seat pivot retaining pin installed.
19. If engine stalls or loses headway and cannot make it to the top of a slope, do not turn machine around. Always back slowly straight down the slope.
20. Raise cutting decks and latch securely in transport position before driving from one work area to another.
21. **DON' T TAKE AN INJURY RISK!** When a person or pet appears unexpectedly in or near the mowing area, STOP MOWING. Careless operation, combined with terrain angles, ricochets, or improperly positioned guards can lead to thrown object injuries. Do not resume mowing until area is cleared.
22. Do not touch engine, muffler or exhaust pipe while

engine is running or soon after it is stopped. These areas could be hot enough to cause burns.

23. If cutting deck strikes a solid object or vibrates abnormally, stop immediately, turn engine off, set parking brake and wait for all motion to stop. Inspect for damage. If damaged, repair or replace any components before operating.
24. Before getting off the seat:
- A. Set parking brake.
 - B. Move traction pedal to neutral and axle shift to HI or LO position.
 - C. Disengage cutting decks and wait for blades to stop.
 - D. Stop engine and remove key from switch.
 - E. Do not park on slopes unless wheels are chocked or blocked.
25. Use only a rigid tow bar if it becomes necessary to tow machine. Use trailer for normal transport.

Maintenance

26. Before servicing or making adjustments, stop engine and remove key from the switch.
27. Make sure machine is in safe operating condition by keeping all nuts, bolts and screws tight.
28. Make sure all hydraulic line connectors are tight, and all hydraulic hoses and lines are in good condition before applying pressure to the system.
29. Keep body and hands away from pin hole leaks or nozzles that eject high pressure hydraulic fluid. Use cardboard or paper to find hydraulic leaks. Hydraulic fluid escaping under pressure can penetrate skin and cause injury. Fluid accidentally injected into the skin must be surgically removed within a few hours by a doctor familiar with this form of injury or gangrene may result.
30. Before disconnecting or performing any work on the hydraulic system, all pressure in system must be relieved by lowering cutting units to the ground and stopping engine.
31. If major repairs are ever needed or assistance is

desired, contact an authorized Toro distributor.

32. To reduce potential fire hazard, keep engine area free of excessive grease, grass, leaves and dirt. Clean protective screen on back of machine frequently. Never wash a warm engine or electrical connections with water.
33. If engine must be running to perform maintenance or an adjustment, keep hands, feet, clothing and other parts of the body away from cutting units and other moving parts. Keep all bystanders away.
34. Do not overspeed the engine by changing governor setting. To assure safety and accuracy, have an Authorized Toro Distributor check maximum engine speed.
35. Shut engine off before checking or adding oil to the crankcase.
36. Disconnect battery before servicing the machine. If battery voltage is required for troubleshooting or test procedures, temporarily connect the battery.
37. At the time of manufacture, the machine conformed to the safety standards for riding mower. Ballast weight, mounted to rear of traction unit, is required for machine to conform to safety standard. DO NOT remove ballast weight at any time. To assure optimum performance and continued safety certification of the machine, use genuine Toro replacement parts and accessories. Replacement parts and accessories made by other manufacturers may result in non-conformance with the safety standards, and the warranty may be voided.

Sound Pressure Level

This unit has an equivalent continuous A-weighted sound pressure at the operator ear of: 89 dB(A), based on measurements of identical machines per Directive 98/37/EC and amendments.

Sound Power Level











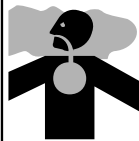

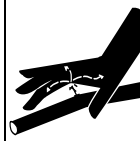

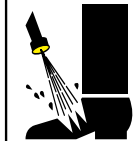
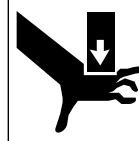
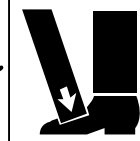

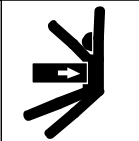
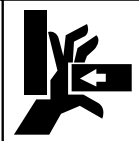
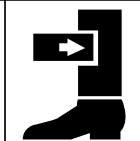
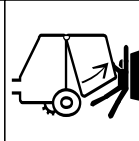
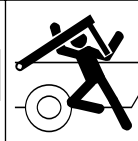
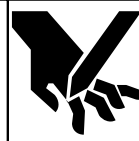
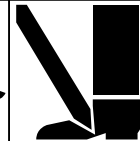
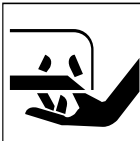



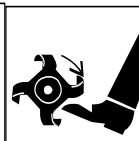

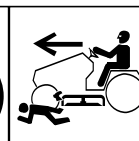
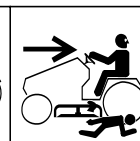

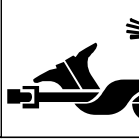
This unit has a guaranteed sound power level of: 105 dB(A)/1pW, based on measurements of identical machines per Directive 2000/14/EC and amendments.

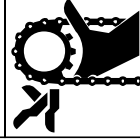
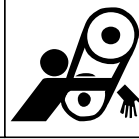
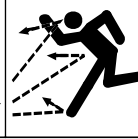
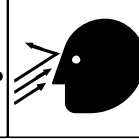
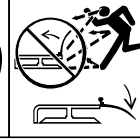
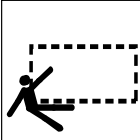
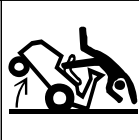
Vibration level

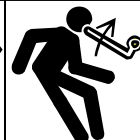
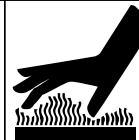
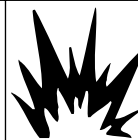
Hand-Arm

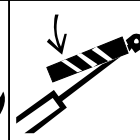
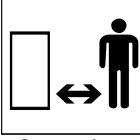
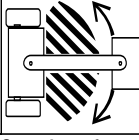
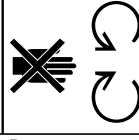
This unit does not exceed a vibration level of 2.5 m/s² at the hands based on measurements of identical machines per ISO 5349 procedures.

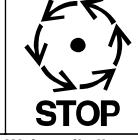
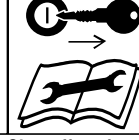
Symbol Glossary

							
Caustic liquids, chemical burns to fingers or hand	Poisonous fumes or toxic gases, asphyxiation	Electrical shock, electrocution	High pressure fluid, injection into body	High pressure spray, erosion of flesh	High pressure spray, erosion of flesh	Crushing of fingers or hand, force applied from above	Crushing of toes or foot, force applied from above
							
Crushing of whole body, applied from above	Crushing of torso, force applied from side	Crushing of fingers or hand, force applied from side	Crushing of leg, force applied from side	Crushing of whole body	Crushing of head, torso and arms	Cutting of fingers or hand	Cutting of foot
							
Severing of fingers or hand, mower blade	Severing of toes or foot, mower blade	Severing of toes or fingers, rotary mower blade	Cutting or entanglement of foot, rotating auger	Severing of foot, rotating knives	Severing of fingers or hand, impeller blade	Dismemberment, front engine mower in forward motion	Dismemberment, front engine mower in rearward motion
							
Severing of fingers or hand, engine fan	Whole body entanglement, implement input drive line	Fingers or hand entanglement, chain drive	Hand & arm entanglement, belt drive	Thrown or flying objects, whole body exposure	Thrown or flying objects, face exposure	Thrown or flying objects, rotary mower	Thrown or flying objects, rotary mower
							
Runover/backover, vehicle	Machine tipping, riding mower	Machine rollover, ROPS (rear engine mower)	Stored energy hazard, kickback or upward motion	Hot surfaces, burns to fingers or hands	Explosion	Fire or open flame	Secure lifting cylinder with locking device before getting in hazardous area
							
Stay a safe distance from the machine	Stay clear of articulation area while engine is running	Do not open or remove safety shields while engine is running	Do not step on loading platform if PTO is connected to tractor & engine is running	Do not step	Wait until all machine components have completely stopped before touching them	Shut off engine & remove key before performing maintenance or repair work	Riding on this machine is allowed only on a passenger seat & only if the driver's view is not hindered

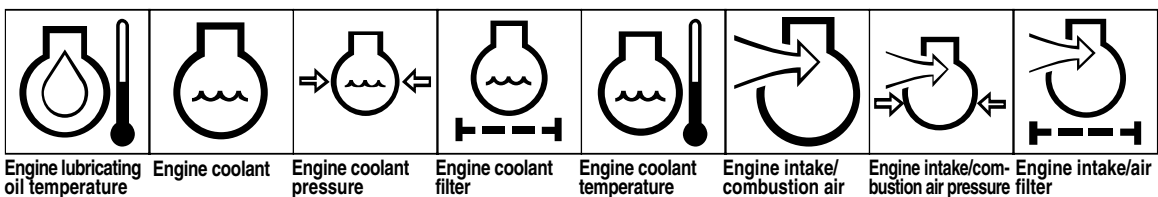
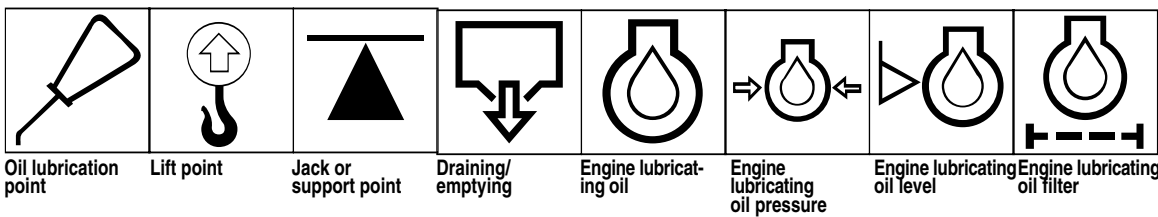
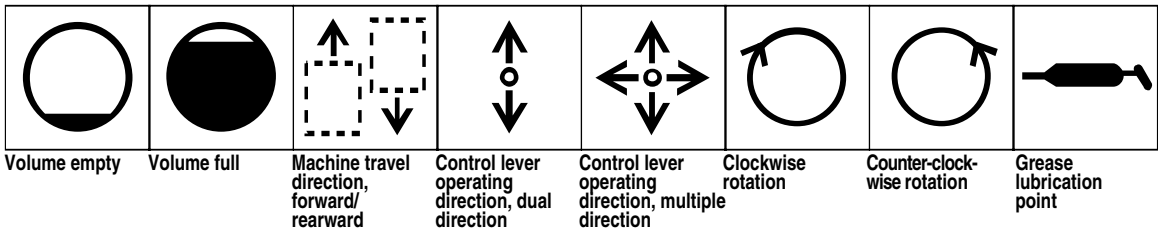
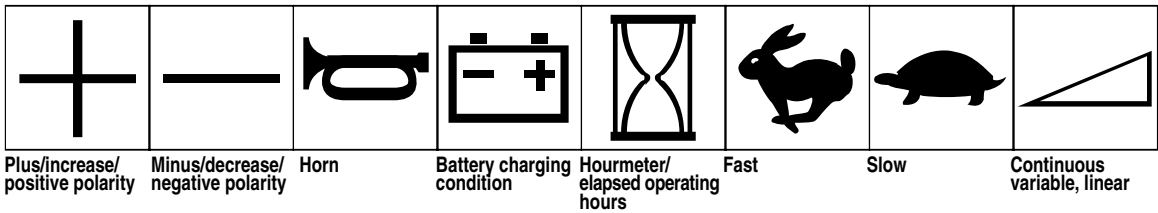
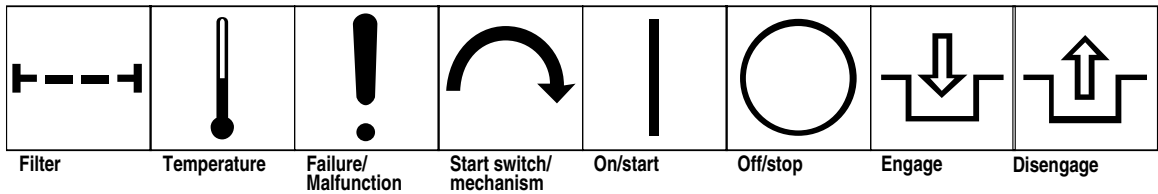
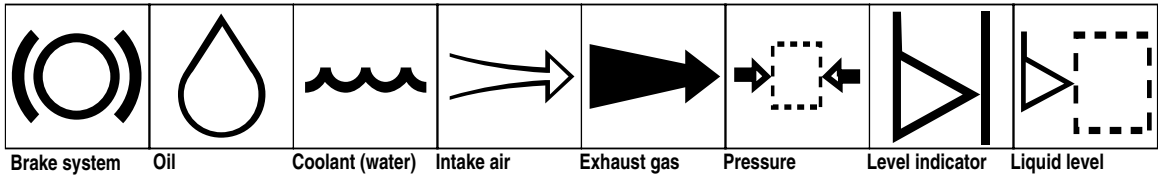
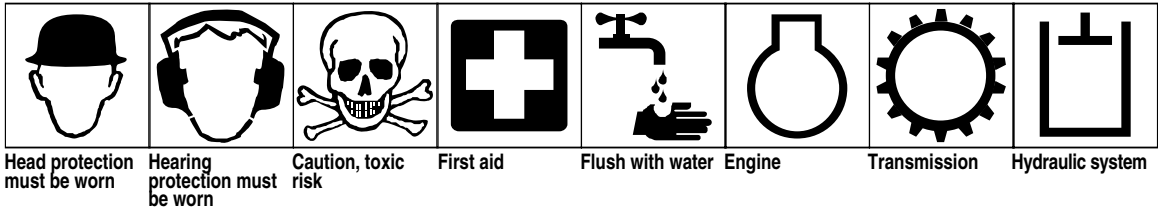
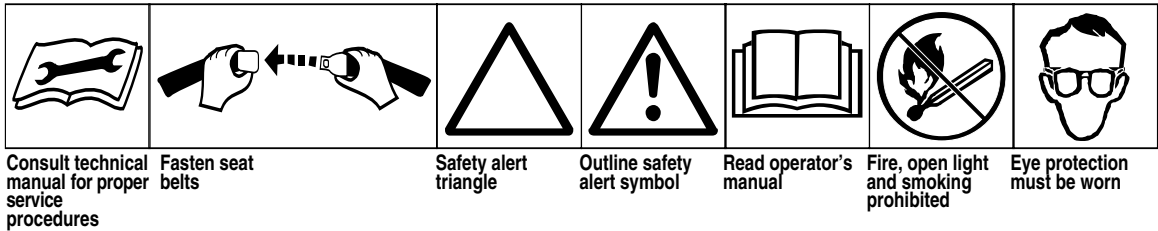

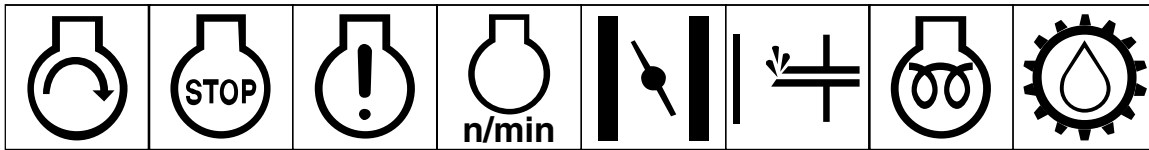

Engine start Engine stop Engine failure/malfunction Engine rotational speed/frequency Choke Primer (start aid) Electrical preheat (low temperature oil start aid) Transmission (low temperature oil start aid)

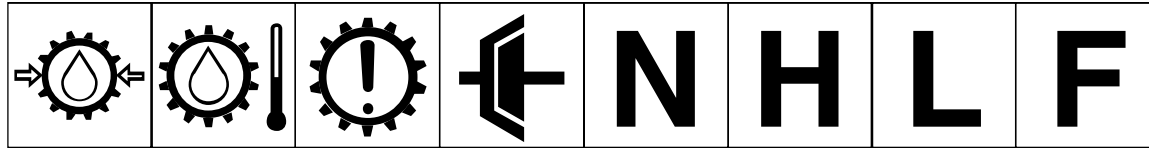

Transmission oil pressure Transmission oil temperature Transmission failure/malfunction Clutch Neutral High Low Forward



Reverse Park First gear Second gear Third gear (other #'s may be used until the maximum # of forward gears is reached.) Hydraulic oil Hydraulic oil pressure Hydraulic oil level

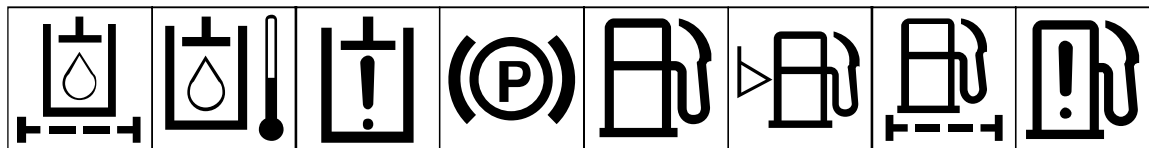

Hydraulic oil filter Hydraulic oil temperature Hydraulic oil failure/malfunction Parking brake Fuel Fuel level Fuel filter Fuel system failure/malfunction

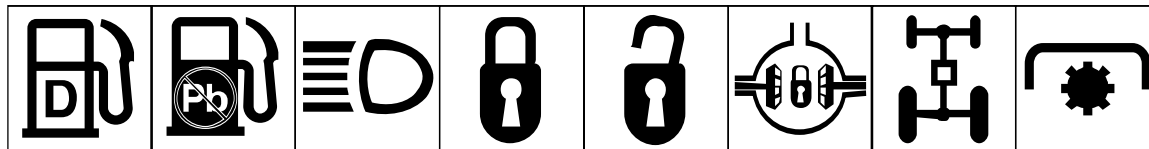

Diesel fuel Unleaded fuel Headlights Lock Unlock Differential lock 4-Wheel drive Power Take-Off

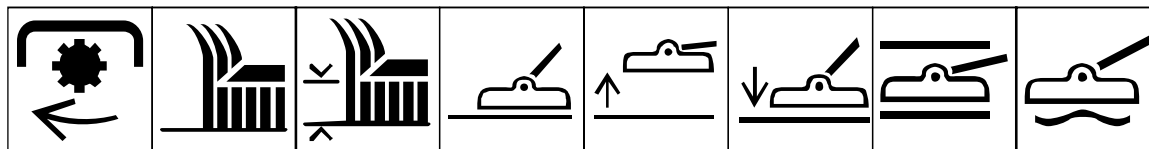

Power Take-Off, rotational speed Blade cutting element Blade cutting element, height adjustment Cutting unit Cutting unit, raise Cutting unit, lower Cutting unit, hold Cutting unit, float

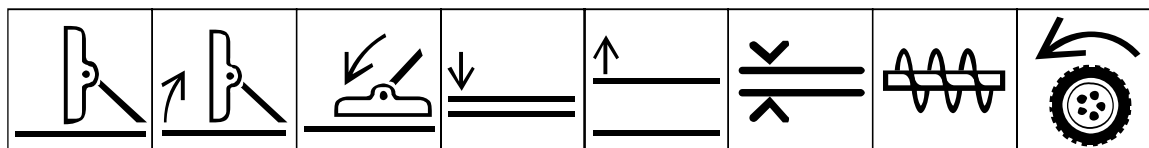

Cutting unit, transport position Cutting unit, raise to transport position Cutting unit, lower to transport position Attachment raise Attachment raise Spacing distance Snow thrower, collector auger Traction

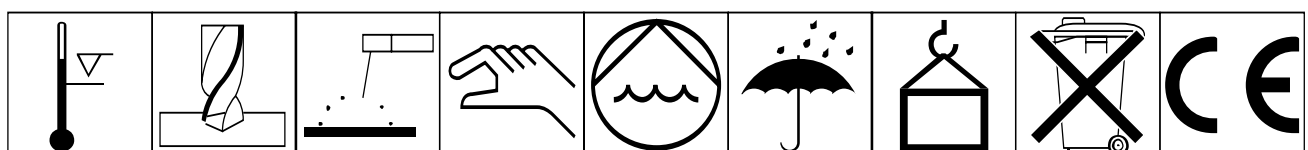

Above working temperature range Drilling Manual metal arc welding Manual Water pump Keep dry Weight Do not dispose in the garbage CE logo

Specifications

Traction Unit

Engine: Peugeot, four-cycle, four-cylinder, 1.9 liter (1,900 cc) displacement, liquid-cooled diesel engine. 23.5:1 compression ratio. Low idle—1,500 rpm, high idle—3,000 rpm. Oil capacity is 5.3 qts. with filter.

Cooling System: Capacity is 13.2 l (3.5 gal) of 50/50 mixture of Peugeot recommended anti-freeze.

Fuel System: Capacity is 53 liter (14 gallon) of #1 or #2 diesel fuel.

Hydraulic System: Reservoir capacity is 24.6 liters (6.5 gallon). Replaceable spin-on filter element.

Traction System: Ground speed: Low Range; 0–10.5 kmh, 0–6.5 mph (0–5.5 mph. with mechanical speed limiter interlock) forward and 0–4.8 kmh, 0–3 mph reverse. High Range): 0–24.1 kmh, 0–15 mph (0–20 kmh, 0–12.4 m.p.h. with mechanical speed limiter interlock) forward and 0–8 kmh, 0–5 mph reverse.

Front Axle: Two-speed axle is designed to withstand heavy-duty slope operation and side loading. Separate mowing and transport selections for faster and more efficient machine operation. Neutral position allows easy towing.

Rear Axles: Two-Wheel Drive—The large diameter wheel spindles are designed for durability and long wear, yet provide superior stability and maneuverability.

Four-Wheel Drive—Heavy-duty, agricultural type. Hydraulic drive with “on demand” bi-directional clutch and balanced weight distribution provides superior traction on hillsides.

Tires/Wheels: High flotation turf tread tires on demountable rims. Front tires: (2) 26 x 12.0-12, 8 ply. Rear tires: (2) 20 x 10.0-10, 6 ply. Tire pressure 138 kPa (20 psi).

Seat: Adjustable fore and aft travel and weight.

Diagnostic System: Test ports for: forward and reverse traction (2-wheel drive), front and rear axle motors (4 wheel drive), lift and counterbalance circuit, steering circuit and charge circuit.

Steering System: Automotive type, full power.

Brakes: Totally enclosed, non asbestos, dry multi-disc individual wheel and parking brakes on front traction wheels. Brakes controlled by individual pedals operated by the left foot. Dynamic braking through closed-loop hydrostatic drive.

Electrical System: 12-volt battery with 530 cold cranking Amps @ –18°C (0° F). 55-amp alternator, ammeter, starter, key switch and automatic temperature controlled glow plug controller. Separately-fused run, deck and instrument/accessory circuits.

Interlock System: Stops the engine if operator gets off the seat while the cutting deck drive switch is engaged or the traction pedal is forward or reverse. Prevents the engine from starting unless the traction pedal is in neutral and the cutting deck is disengaged. Prevents the cutting deck from operating unless the axle shift is in LO range.

Warning Lights:

Glow plug indicator
Engine oil pressure warning
Engine coolant temperature warning
Charge indicator
Water in Fuel
Low-Water indicator

Indicators:

Engine coolant temperature gauge
Fuel gauge
Hour meter

The Cutting Unit

Type: 320 cm (126 inch) width of cut, seven-blade, front-mounted rotary. 137 cm (54 inch) width of cut, three-blade center section. Two 94 cm (36 inch) width of cut wings; 229 cm (90 in.) width of cut with one wing up. Rear discharge with even dispersion over the entire width of cut.

Mowing Rate: Mows up to 19 hectares/hour. at 10.5 kmh (6.5 mph).

Trimability: Trims on both sides.

Height-of-Cut: Adjustable from 2.5–12.7 cm (1–5

inches) in 1.2 cm (0.5 inch) increments. Seven 48 cm (19 inches) long, 6 mm (1/4") thick, and 64 mm (2-1/2 in.) wide, heat treated steel blades.

Belt Idlers: Self-tensioning permanently lubricated idlers.

Wing Decks: Wings can be hydraulically raised from the operator’s seat for transport or cutting with either wing and center deck or center deck only. Wings cut from level to 15° up and down. Further lift disengages the blade and applies a blade brake.

Suspension/Caster Wheels: Four front and two rear pneumatic castor tires with ball bearings. Center deck tires: 26–8.3 cm (10.25 in. x 3.25 in.). Wing deck tires: 20 x 8.3 cm (8 in. x 3.25 in. An anti-scalp cup is located on each blade. Three anti-scalp rollers on the center deck. Deck is hydraulically counterbalanced.

General Specifications (approx.):

Overall Length:	
With the deck installed	340 cm (134 in.)
Overall Width:	
Transport	190.5 cm (75 in.)
Mowing	323 cm (127 in.)
Height:	147 cm (58 in.)
With rollover protection system installed	208 cm (82 in.)
Wheel Tread:	
(Front)	129.5 cm (51 in.)
(Rear)	104 cm (41 in.)
Wheel Base:	142 cm (56 in.)
Wheel Tread:	132 cm (52 in.)
Dry Weight:	
2-Wheel Drive	1,418 kg (3,800 lb)
4-Wheel Drive	1,455 kg (3,900 lb)

Optional Equipment

Broom Kit, Contact Your Local Toro Distributor
 Snowthrower, Contact Your Local Toro Distributor

Roll-Over Protection Kit, Contact Your Local Toro Distributor (Standard on Model 30455)
 4-Post Canopy Kit, Contact Your Local Toro Distributor
 Spark Arrestor Muffler, Part No. 94-5637
 Segmented Wheel Kit, Part No. 76-1880
 Brake Light Kit, Part No. 92-7763
 Gear Box Pulley (Tip Speed 14,500), Part No. 86-3100
 Windshield Kit, Contact Your Local Toro Distributor
 Cruise Control Kit, Model No. 30485
 Road Light Kit, Model No. 30471
 Mulcher Kit, Model No. 30475 Cab, Contact Your Local Toro Distributor
 Additional Weights, Contact Your Local Toro Distributor
 Low Seat Option, Contact Your Local Toro Distributor

Specifications and design subject to change without notice.

Before Operating



CAUTION



Before servicing or making adjustments to the machine, stop the engine and remove the key from the switch

Check the Engine Oil

Crankcase capacity is 5 liters (5.3 qt) with filter.

1. Park the machine on a level surface. Release the hood latch and open the hood.



Figure 1

1. Hood latch

2. Remove the dipstick from the tube cap, wipe it clean and reinstall the dipstick into the tube cap. Pull it out again and check the oil level on the dipstick: The oil level must always be in the notch area on the dipstick.



Figure 2

1. Dipstick/tube cap

3. If the oil level is low, remove the tube cap and add SAE 10W-30 CD oil until the level reaches the top of notch on the dipstick. **DO NOT OVERFILL.**
4. Install the oil tube cap.

5. Close the hood and secure the latch.

Check the Cooling System

Capacity of the system is 13.2 liters (3.5 gal).

1. Park the machine on a level surface. Release the hood latch and open the hood.
2. Check the coolant level. **The coolant level should be up to or above the mounting tabs on the degasser tank, when the engine is cold.**

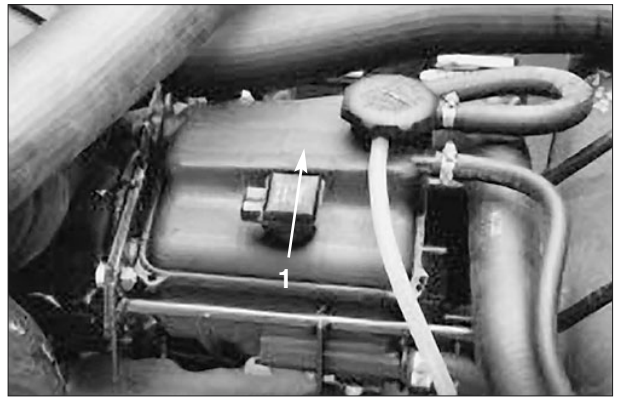

Figure 3

1. Degasser tank

3. If the coolant is low, remove the degasser tank cap and add a 50/50 mixture of water and Peugeot recommended anti-freeze (Toro Part No. 93-7213). **Do not use water only or alcohol/ methanol-based coolants.**

IMPORTANT: Do not remove the black plastic cap on the degasser tank.

4. Install the degasser tank cap.
5. Close the hood and secure the latch.

Fill the Fuel Tank

1. Park the machine on a level surface. Release the hood latch and open the hood.
2. Remove the fuel tank cap.

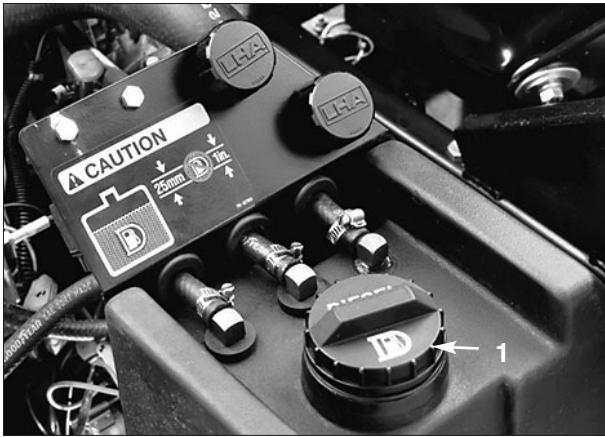

Figure 4

1. Fuel tank cap

- Fill the tank to no more than one inch below the bottom of the filler neck with No. 2 diesel fuel. DO NOT OVER FILL. Then install the cap.

Note: For temperatures below 0° C (32° F), No. 1 diesel fuel or a blend should be used.

! DANGER !

Because diesel fuel is highly flammable, use caution when storing or handling it. Do not smoke while filling the fuel tank. Do not fill the fuel tank while the engine is running, hot, or when the machine is in an enclosed area. Always fill the fuel tank outside and wipe up any spilled diesel fuel before starting the engine. Store the fuel in a clean, safety-approved container and keep the cap in place. Use diesel fuel for the engine only; not for any other purpose.

- Close the hood and secure the latch.

Check the Hydraulic Circuit Oil

The hydraulic system is designed to operate on Mobil DTE 15M or equivalent anti-wear hydraulic fluid. The machine's reservoir is filled at the factory with approximately 24.6 L of Mobil DTE 15M hydraulic fluid. However, check the level of hydraulic fluid before the engine is first started and daily thereafter. Appropriate hydraulic oils are listed below.

Group 1 Hydraulic Fluid (Moderate climate—average duty)

Note: The fluids within this group are interchangeable.

ISO VG 46/68 multi-viscosity anti-wear hydraulic fluid

Mobil	DTE 15M
Amoco	Rykon Premium ISO 46
Castrol	AWH 46
Conoco	Hydroclear AW MV46
Gulf	Harmony HVI 46 AW
Kendall	Hyken Golden MV SAE 5W-20
Pennzbell	AWX MV46
Phillips	Magnus A KV 5W-20
Shell	Tellus T 46
Sunoco	Sun Hyd. Oil 2105
Texaco	Rando HDZ 46

Universal Tractor Hydraulic Fluid

Mobil	Mobilfluid 424
Amoco	1000 Fluid
Chevron	Tractor Hydraulic Fluid
Conoco	Hydroclear Powertran
Esso	Hydraul
Gulf	Universal Tractor Fluid
Kendall	Hyken 052
Marathon	Maraf fluid Super HT
Pennzoil	Hydra-trans
Phillips	HG Fluid
Shell	Donax TD
76 Lubricants	Hydraulic/Tractor Fluid
Sunoco	TH Fluid
Texaco	TDH

Group 2 Hydraulic Fluid (Hot Climate- Heavy Duty)

Note: The fluids within this group are interchangeable.

ISO VG 68 anti-wear hydraulic fluid

Mobil	DTE 26
Amoco	Rykon AW No. 68
Castrol	AWS 68
Chevron	Hydraulic Oil AW ISO 68
Conoco	Hydroclear AW 68
Exxon	Nuto H 68
Gulf	Harmony 68AW
Kendall	Four Seasons AW 68
Marathon	IS068
Pennzbell	AW Hydraulic Oil 68
Phillips	Magnus A ISO 68
Shell	Tellus 68
76 Lubricants	AW 68
Sunoco	SunVis 868
Texaco	Rando HD 68

IMPORTANT- Group 1 fluids are recommended for use at typical ambient temperatures 0°C to 41°C. The ISO Type 46/48 fluid has been found to offer

optimal performance in a wide range of temperature conditions for the average user. The Universal Tractor Fluids offer similar performance for those who prefer them, with perhaps some slight loss of efficiency at high ambient temperatures compared to the Type 46/48 fluids.

Group 2 fluids are recommended for heavy-duty use in hot climates where ambient temperatures range from about 20°C to 49°C. Use at lower ambient temperatures may result in hard starting, increased engine laboring while cold, sluggish or non-operating valves while cold and high filter back pressure due to the higher viscosity of these fluids.

Note: When changing from one type of hydraulic fluid to another, be certain to remove all the old fluid from the system, as some fluids are incompatible with others.

Important: Use only hydraulic oils specified. Other fluids could cause system damage.

Note: A red dye additive for the hydraulic system fluid is available in 19.8 ml bottles. One bottle is sufficient for 22 L of hydraulic fluid. Order Part No. 44-2500 from your Authorized Toro Distributor.

1. Park the machine on a level surface. Make sure the machine has been operated so the oil is warm. Release the hood latch and open the hood. Check the oil level by viewing the sight gauge. If oil is visible in the gauge, the oil level is sufficient.
2. If the oil level is not visible in the gauge, remove the cap from the hydraulic oil reservoir and slowly add Mobil DTE 15 or equivalent hydraulic oil until the level reaches the middle (maximum) of the sight gauge. **DO NOT OVER FILL.**

IMPORTANT: To prevent system contamination, clean the tops of hydraulic oil containers before puncturing. Make sure the pour spout and funnel are clean.

3. Install the reservoir cap, close the hood and secure the latch.

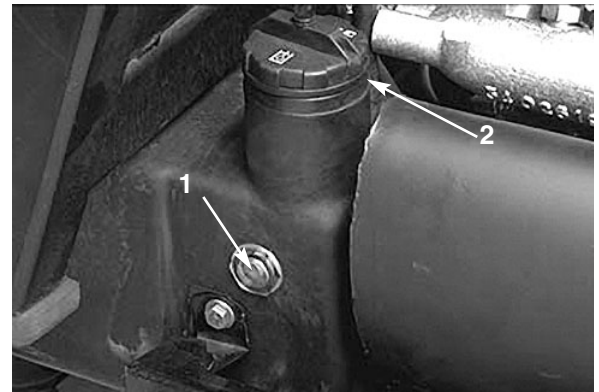

Figure 5

1. Sight gauge
2. Hydraulic reservoir cap

Check the Front Axle Oil Level

The front axle is shipped from the factory filled with SAE 80–90 weight gear lubrication. However, check the level before the engine is first started and every 50 hours thereafter. Capacity is 378cl (128 oz.). Check daily for signs of oil loss.

1. Park the machine on a level surface.
2. Remove the access panel (Fig. 6), in the front of the seat, to expose the front axle/dipstick.



Figure 6

1. Access panel

3. Unscrew the dipstick cap (Fig. 7) from the filler neck and wipe it with a clean cloth. Screw the dipstick cap finger tight onto the filler neck. Unscrew the dipstick and check the level of lubricant. If the level is not within 12mm (1/2 in.) from the groove in the dipstick, add enough to raise the level to the groove mark. **DO NOT OVERFILL** by more than 12mm (1/2 inch) above the groove.

4. Screw the dipstick filler cap finger-tight onto the filler neck. It is not necessary to tighten the cap with a wrench.

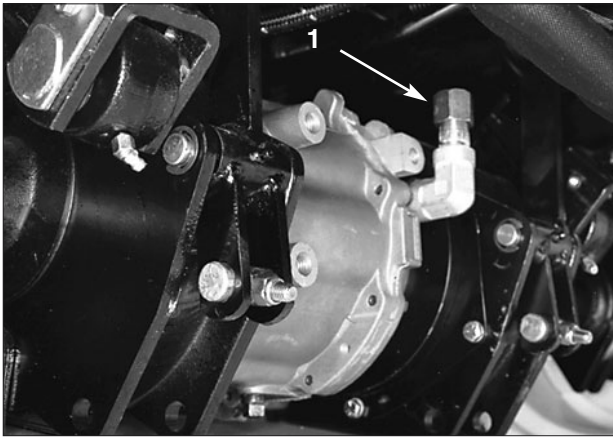

Figure 7

1. Dipstick cap

Check the Rear Axle Lubricant (Model 30455 Only)

The rear axle is shipped from the factory filled with SAE 80–90 weight gear lubrication. However, check the level before the engine is first started and every 50 hours thereafter. Capacity is 237cl (80 oz).

1. Position the machine on a level surface.
2. Clean area around the (3) check plugs, (1) on each end and (1) in the center (Fig. 8).
3. Remove the check plugs and make sure lubricant is up to bottom of hole. If level is low, add enough lubricant to bring the level up to the bottom of the check plug holes.



Figure 8

1. Vent/fill plug
2. Check plug (3)



Figure 9

1. Check/fill plug

Check Bi-Directional Clutch Lubricant

(Model 30455 Only) (Fig. 10)

The Bi-directional Clutch is shipped from the factory filled with Mobil DTE 15 M anti-wear hydraulic fluid. However, check the level before the engine is first started and every 50 hours thereafter. Capacity is 8 oz. Check daily for signs of oil loss.

1. Position the machine on a level surface.
2. Remove the check/fill plug from the clutch housing and make sure lubricant is up to bottom of the hole. If the level is low, add enough lubricant to bring the level up to the bottom of the check/fill plug hole.

Note: Do not use gear lube in the clutch housing.

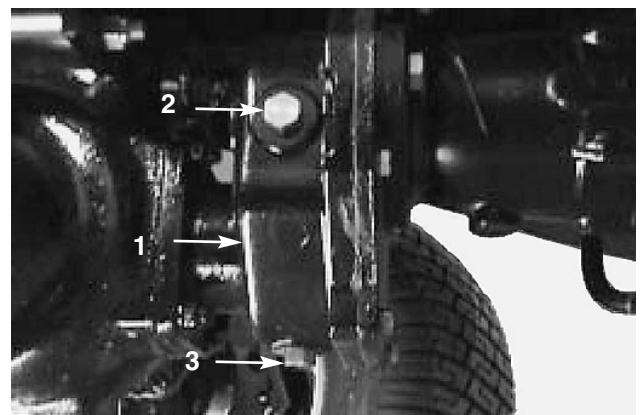

Figure 10

1. Clutch housing
2. Check/fill plug
3. Drain plug

Check Tire Pressure

The tires are over-inflated for shipping. Therefore, release some of the air to reduce the pressure. Correct air pressure in the front and rear tires is 138 kPa (20 psi).

IMPORTANT: Maintain even pressure in all tires to assure a good quality-of-cut and proper machine performance. DO NOT UNDER INFLATE.

Check the Torque of Wheel Nuts Or Bolts

!
WARNING
!

Torque the front wheel nuts to 45–55 ft-lb and the rear wheel nuts or bolts to 85–100 ft lb after 1–4 hours of operation and again after 10 hours of operation and every 250 hours thereafter. Failure to maintain correct torque could result in failure or loss of the wheel and may result in personal injury.

Check the Lubricant In the Gear Box

The gear box is designed to operate on SAE 80–90 weight gear lubrication. Although the gear box is shipped with lubricant from the factory, check the lubricant’s level before operating the cutting unit. Check daily for signs of loss.

1. Position the machine and cutting unit on a level surface.
2. Remove the check plug from the side of the gear box and make sure lubricant is up to the bottom of the hole. If the level of lubricant is low, remove the fill plug on top of the gear case and add enough lubricant to bring it up to the bottom of the hole inside.

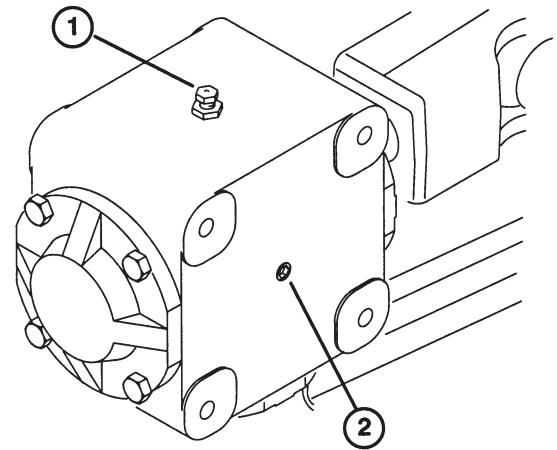

Figure 11

1. Filler plug/pressure relief valve
2. Check plug

Adjusting the Height Of Cut

The height-of-cut is adjustable from 2.5–12.7 cm (1 to 5 inches) in 12.7 mm (0.5 inch) increments. Positioning the castor wheel axles in the top holes of the castor forks or pivots (see chart below) allows low-range height-of-cut settings from 2.5–8.3 cm (1 to 3-1/2 in); positioning the castor wheel axles in the lower holes of the front castor forks or rear castor pivots (see chart below) allows a high-range height-of-cut settings from 6–12 cm (2-1/2 to 5 in.)

HEIGHT OF CUT—FRONT CASTOR WHEELS

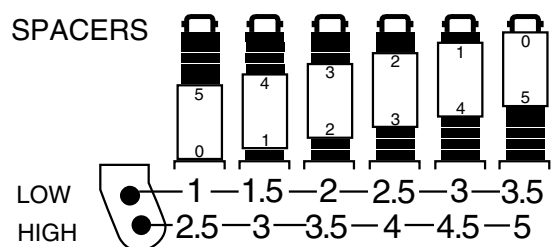

HEIGHT OF CUT —REAR CASTOR WHEELS

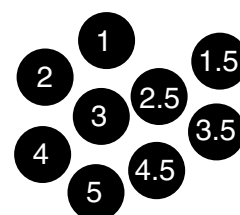

HEIGHT OF CUT —REAR DECK STRAPS

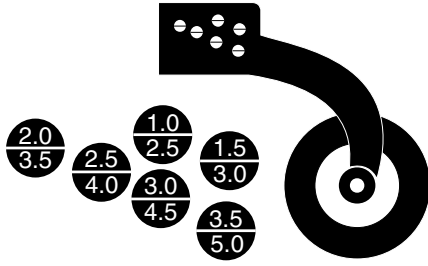

1. Start the engine and raise the cutting unit so the height-of-cut can be changed. Stop the engine after the cutting unit is raised.
2. Position all castor wheel axles in the same holes in the castor forks or pivots.

Front Castor Wheels

1. Remove the height-of-cut cap from the spindle shaft and slide the spindle out of the front castor arm. Slide spacers onto the spindle shaft to get desired height of cut.
2. Push the castor spindle through the front castor arm. Install remaining spacers onto spindle and install height-of-cut cap to secure the assembly.

Note: On the center deck only, make sure the washer remains on the bottom of the spindle shaft.



Figure 12

1. Front castor wheel
2. Height-of-cut cap
3. Spacers
4. Washer (center deck only)

Rear Castor Wheels

1. Remove the hairpin cotter and height-of-cut pin securing the rear castor pivot arm to the deck bracket.



Figure 13

1. Rear castor pivot

2. Align the pivot arm holes with selected height-of-cut bracket holes in the deck frame, install the height-of-cut pin and secure with the hairpin cotter.

Rear Deck Straps

1. Lower the center and wing cutting units to the ground: then raise the center cutting unit slightly, until the rear deck straps hang freely on the lift arm brackets. Stop the engine after the cutting unit is raised.

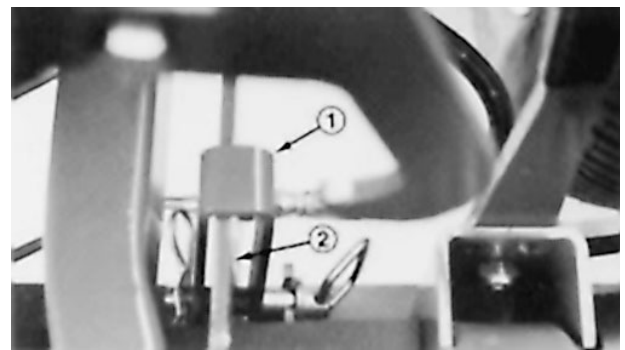



Figure 14

1. Rear deck straps
2. Lift arm Brackets

2. Remove the hairpin cotter and height-of-cut pin securing the rear deck strap to the height-of-cut bracket on the deck.
3. Slide the deck strap forward or backward until the holes in strap are aligned with selected height-of-cut bracket holes in the deck frame, install the height-of-cut pin and secure it with the hairpin cotter.

Safety Doors

On each side of the center deck is a safety door that opens and closes as the wing decks are lowered and raised (Fig. 13). The doors open to provide overlap of the cutting blades when the wing units are down. The doors close to provide safety and protection when the wing units are raised. Check to make sure the forward, lower edge of door is even or 6 mm (1/4 in.) higher than lower edge of door guide when wing decks are in the fully raised, transport position. If an adjustment to the door is required, refer to *Adjusting The Safety Door*.

	CAUTION	
Check for correct operation of the safety doors each time the deck is cleaned and repair when needed.		

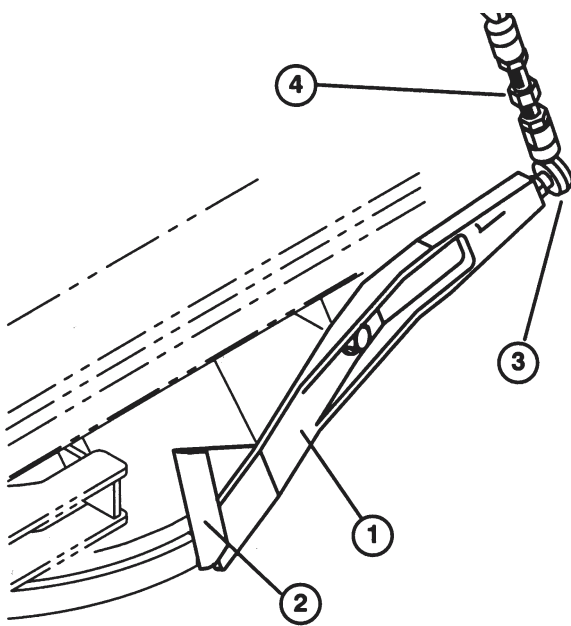

Figure 15

1. Safety door
2. Door guide
3. Ball joint
4. Threaded rod

Controls

Cutting Unit Engagement Switch (Fig. 16)—Used to start and stop cutting unit operation. Lift switch and move forward to actuate the cutting unit. Center deck will engage first followed by wing decks engaging approximately one second later.

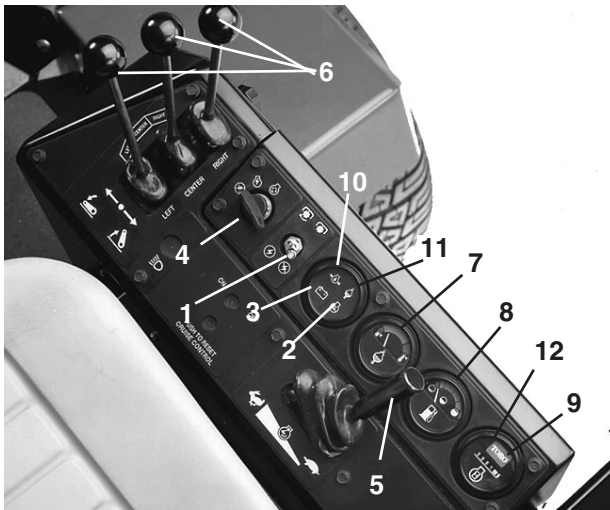

Figure 16

1. Cutting unit engagement switch
2. Glow plug indicator
3. Charge indicator
4. Key switch
5. Throttle control
6. Cutting unit lift controls
7. Coolant temperature gauge
8. Fuel gauge
9. Low-water indicator
10. Engine oil pressure warning light
11. Engine coolant temperature warning light
12. Water-in-fuel warning light

Glow Plug Indicator (Fig. 16)—Automatically actuates proper glow period when the ignition key is turned to ON. Illuminates when the glow plugs are actuated. When the glow plugs are heated sufficiently, light goes off indicating the engine is ready to start.

Charge Indicator (Fig. 16)—Illuminates when the system charging circuit malfunctions.

Key Switch (Fig. 16)—Three positions: OFF, ON and START. Turn the key to START and release it when the engine begins running. To stop the engine, turn the key to OFF.

Throttle Control (Fig. 16)—Move control forward to increase the engine speed, backward to decrease speed.

Cutting Unit Lift Controls (Fig. 16)—The two outside levers raise and lower the wing cutting units. The center

lever raises and lowers the whole cutting unit. The engine must be running to lower the cutting unit. When wing cutting units are raised higher than 15°, their blades automatically disengage. To lower the cutting unit just touch the levers momentarily.

Coolant Temperature Gauge (Fig. 16)—Shows the temperature of engine coolant.

Fuel Gauge (Fig. 16)—Shows the amount of fuel in the tank.

Low-Water Indicator (Fig. 16)—Indicates low water level in the cooling system.

Engine Oil Pressure Warning Light (Fig. 16)—Indicates dangerously low engine oil pressure.

Engine Coolant Temperature Warning Light (Fig. 16)—The red light illuminates and the engine stops when temperature of the coolant exceeds 110° C (230° F)

Water-In-Fuel Indicator (Fig. 16)—Indicates when there is water in the fuel.

Seat (Fig. 17)—Seat adjusting lever on the left side of the seat allows 4 inch fore and aft adjustment. The seat adjusting knob on the front of the seat, adjusts the seat for operator's weight.

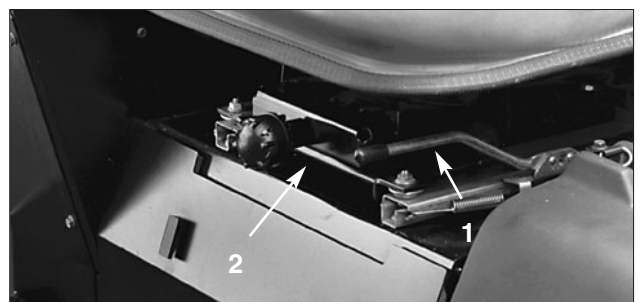

Figure 17

1. Seat adjusting lever
2. Seat adjusting knob

Traction Pedal (Fig. 18)—Controls forward and reverse operation. Depress the top of the pedal to move forward and the bottom to move backward. Ground speed depends on how far the pedal is depressed. For no load, maximum ground speed, fully depress the pedal while the throttle is in FAST. For maximum power under load

or when going uphill, keep the engine rpm high by having the throttle in FAST and the traction pedal partially engaged. If engine rpm begins to decrease due to load, gradually reduce the traction pedal pressure until engine speed is increased.

To stop, reduce foot pressure on the traction pedal and allow it to return to the center position. On extreme downhill slopes, apply pressure to REVERSE side of the pedal, or operate with heel on REVERSE and toe on FORWARD portion of the pedal.



Figure 18

1. Traction pedal
2. Axle shift lever
3. Lockout knob

Speed Selector (Fig. 18)—The cam lever at the side of the traction pedal can be rotated to maintain the desired speed. Rotating the lever forward decreases speed and backward increases speed.

Axle Shift Lever (Fig. 18)—Located on the right side of console, the lever selects the front drive mode. Pull out the lock-out knob, move the lever rearward for mowing operation and forward for transport operation, then release the knob to lock the selection. The lever must be in LO position to mow. Middle position (N) is for towing.

IMPORTANT: On model 30455, the lever must be in LO to operate in 4-wheel drive.

CAUTION: The machine must be on a flat surface and the brakes engaged when shifting the axle from HI to LO

Brake Pedals (Fig. 19)—Two foot pedals at the lower left operate individual wheel brakes for turning assistance, parking and for better side hill traction. The locking pin is for parking.



Figure 19

1. Brake pedals
2. Parking brake latch
3. Steering wheel tilt lever

Parking Brake Latch (Fig. 19)—A knob on the left side of console actuates the parking brake lock. To engage the parking brake, connect the pedals with the locking pin, push down on both pedals and pull the parking brake latch out. To release the parking brake, depress both pedals until the parking brake latch retracts.

Steering Wheel Tilt Lever (Fig. 19)—The lever on the left side of console lets the steering wheel to be adjusted for operator comfort.

Transport Latches (Fig. 20)—Four latches secure the cutting unit and wings in upright position for transport.



Figure 20

1. Transport latch (4)

Horn—In the center of steering wheel. Operates only when the key switch is in ON.

Hour Meter (Under Hood)—Shows total hours that the machine has been operated.

Operating

Starting and Stopping

1. Sit on the seat and keep your foot off the traction pedal. Assure the parking brake is engaged, the traction pedal is in NEUTRAL and the cutting unit engagement switch is in the DISENGAGED position.
2. Turn the ignition switch to ON. When the glow plug indicator light goes off, the engine is ready to START.
3. Turn the ignition key to START. Release the key when the engine starts.
4. To stop, disengage and move all controls to NEUTRAL and set the parking brake. Turn the key to OFF and remove it from switch. Raise and latch all the cutting units in transport position.

Priming the Fuel System

IMPORTANT: The fuel system may need to be primed when a new engine is started for the first time, if it runs out of fuel or if maintenance is performed on the fuel system.

1. Unlatch and raise the hood.
2. Insert a 48 mm (3/16) hose over bleed screw and run other end into a container to catch fuel.
3. Loosen the fuel filter/water separator bleed screw (Fig. 21) a few turns. Pump the priming plunger until a steady stream of fuel comes out of the hole in the bleed screw. When fuel stops foaming, tighten the bleed screw during the down stroke of the priming plunger. Wipe up any spilled fuel.

Note: Priming the fuel filter without opening the bleed screw may damage the priming plunger.

4. Pump the priming plunger until resistance is felt. Try to start the engine. If the engine does not start repeat step 3.

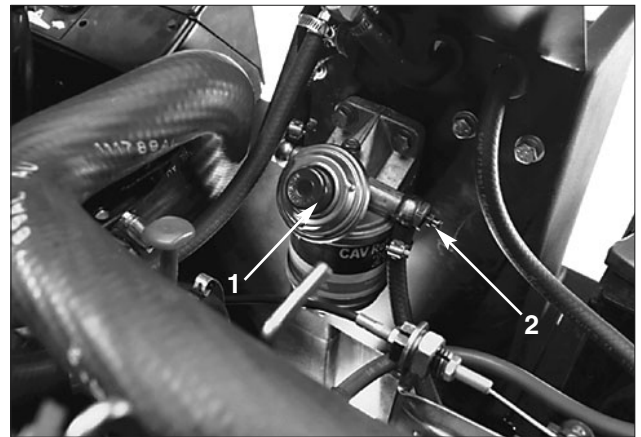

Figure 21

1. Hood plunger
2. Bleed screw

Note: It may be necessary to bleed the air out of the fuel line between the fuel filter/water separator and the injection pump. To do this, loosen the fitting on the injection pump (Fig. 22) and repeat bleeding procedure.

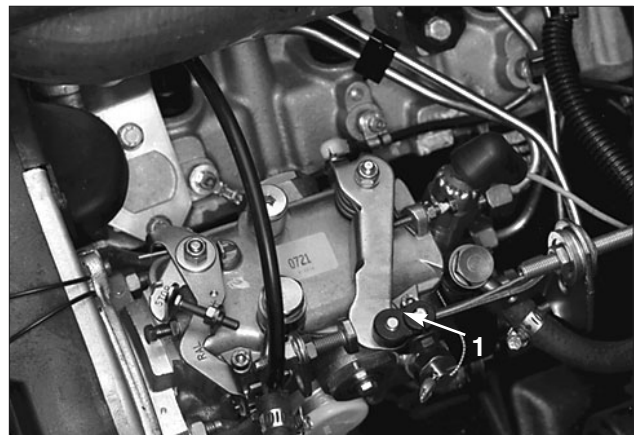

Figure 22

1. Injection pump fitting

Checking the Interlock System

The purpose of the interlock system is to prevent the engine from cranking or starting unless the traction pedal is in NEUTRAL and the cutting unit engagement switch is DISENGAGED. Also, the engine will stop when the cutting unit engagement switch is engaged or the traction pedal is depressed with the operator off the seat.



CAUTION



The interlock switches are for the operator's protection, so do not disconnect them. Check switch operation daily to assure the interlock system is operating. If a switch is defective, replace it before operating. Regardless of whether the switches operate correctly or not, replace them every two years to assure maximum safety. Do not rely entirely on safety switches—use common sense!

1. In a wide open area free of debris and bystanders, lower the cutting unit to the ground. Stop the engine.
2. Move the cutting unit engagement switch to DISENGAGED and remove your foot from the traction pedal so it is fully released.
3. Turn the ignition key to START. The engine should start. If the engine starts, go to step 4. If the engine does not start, there may be a malfunction in the interlock system.
4. Rise from the seat and engage the cutting unit engagement switch while the engine is running. The engine should stop within 2 seconds. If the engine stops, the switch is operating correctly; go to step 5. If the engine does not stop, there is a malfunction in the interlock system.
5. Rise from the seat and depress the traction pedal while the engine is running and the cutting unit engagement switch is DISENGAGED. The engine should stop within 2 seconds. If the engine stops, the switch is operating correctly; continue operation. If the engine does not stop, there is a malfunction in the interlock system.

Operating Characteristics

Familiarization—Before mowing grass, practice operating the machine in an open area. Start and stop the engine. Operate in forward and reverse. When you feel familiar with the machine, practice operating around trees and obstacles. Also drive up and down slopes at different speeds.



WARNING



When operating a 4-wheel drive machine, always use the seat belt and Roll-Over Protection System together and have the seat pivot retaining pin installed.

Another characteristic to consider is the operation of the brake pedals. The brakes can be used to help turn the machine. However, use them carefully, especially on soft or wet grass because the turf may be torn accidentally. Another benefit of the brakes is to maintain traction. For example: When operating on a side hill, the uphill wheel slips and loses traction. If this situation occurs, depress the uphill brake pedal gradually and intermittently until the uphill wheel stops slipping, thus, increasing traction on the downhill wheel.

Warning System—If a warning light comes on during operation, stop the machine immediately and correct the problem before continuing operation. Serious damage could occur if the machine is operated with a malfunction.

Mowing—When you are at the area to be mowed, release the cutting unit transport latches. Move the axle shift lever rearward to Mow and the throttle to FAST so the engine is running at maximum speed. Lift the engagement switch and move forward to engage the cutting units.

Curbside Mowing—To reduce the possibility of foreign debris escaping from under the cutter deck while mowing at or near a road or walkway curb, always keep the outside edge of the cutter deck inside the curb. The cutter deck caster wheels should not be guided along the top of the curb; this could cause the cutter deck to hang over the edge of the curb. Never allow the edge of the cutter deck to extend over the edge of the curb while the blades are turning. Always stop mowing and disengage the mower blades when encountering pedestrians or other bystanders/ passers-by.



Note: The cutting deck is equipped with a breakaway system to prevent wing decks from being damaged if a solid object is struck. If a wing deck strikes a solid object and unlatches from the center cutting deck, raise and lower the wing deck to reset in operating position.

Transport—When mowing is complete, disengage the

cutting unit and raise it by pulling back on the cutting unit lift control levers. Hold the levers back until the cutting unit is fully raised. **Never raise the cutting deck when it is engaged.** Lock the cutting unit in place with transport latches. Move the axle shift lever forward to HI. When driving from one area to another, always shift the axle to LO before encountering a slope. Never shift from HI to LO while on a slope. Stop the machine on a flat surface, engage the brakes and shift before climbing the slope. Be careful when driving between objects so you do not accidentally damage the machine or the cutting unit.

Use extra care when operating the machine on slopes. Drive slowly and avoid sharp turns on slopes to prevent rollovers. The cutting unit must be lowered when going downhill for steering control.

We recommend you use protective equipment, such as protective equipment for eyes, ears, feet and head.

	CAUTION	
<p>This machine produces sound levels in excess of 85 dBA at the operator’s ear and can cause hearing loss through long periods of exposure.</p> <p>Wear hearing protection when operating this machine.</p>		



1. Caution
2. Wear hearing protection

Pushing Or Towing The Traction Unit—Use only a rigid tow bar if it becomes necessary to tow the machine. Make sure the axle shift lever is in NEUTRAL position and only tow the machine forward. Use trailer for normal transport. Move the axle shift lever to LO position before loading the machine on a trailer.

Operating Tips

Mow When Grass Is Dry—Mow either in the late morning to avoid the dew, which causes grass clumping or in late afternoon to avoid the damage that can be caused by direct sunlight on the sensitive, freshly mowed grass.

Select the Proper Height-of-cut Setting To Suit Conditions—Remove approximately 2.5 cm (one inch) or no more than 1/3 of the grass blade when cutting. In exceptionally lush and dense grass you may have to raise your height-of-cut setting another notch.

Mowing In Extreme Conditions—Air is required to cut and re-cut grass clippings in the mower housing, so do not set the height-of-cut too low or totally surround the housing by uncut grass. Try to have one side of the mower housing free from uncut grass, allowing air to be drawn into housing. When making an initial cut through the center of an uncut area, operate the machine slower and back up if the mower starts to clog.

Clippings Discharge—Although the deck has rear discharge, some clippings are discharged toward the left side. To avoid discharging undesirable clippings onto pathways, roads, or other non-turf surfaces, mow with the right side of the deck next to the pathway, road, or other non-turf surface

Mow At Proper Intervals—Under most normal conditions you’ll need to mow every 4–5 days. But remember, grass grows at different rates at different times. This means that to maintain the same height of cut—which is a good practice—you’ll need to cut more often in early spring; as the grass growth rate slows in mid summer, cut it only every 8–10 days. If you’re unable to mow for an extended period, mow first with the height-of-cut at a high level; then mow again 2–3 days later with a lower height setting.

Always Mow With Sharp Blades—A sharp blade cuts cleanly and without tearing or shredding the grass blades. Tearing and shredding causes the grass to turn brown at the edges which impairs growth and increases susceptibility to diseases.

After Operating—To assure optimum performance, clean the underside of the mower housings and under the belt covers after each use. Use low pressure compressed air only. Do not use water. If residue is allowed to build up in the mower housings, cutting performance will decrease.

Maintenance

Minimum Recommended Maintenance Intervals

Maintenance Procedure	Maintenance Interval & Service				
Inspect the air filter, dust cup and baffle Lubricate all grease fittings Check cutting unit gear box oil level	Every 50 hours	Every 100 hours	Every 200 hours	Every 400 hours	Every 800 hours
‡ Change engine oil and filter Check battery level/cable connections Inspect cooling system hoses					
†Inspect PTO and cutting unit belts ‡ Check electric deck clutches adjustment ‡ Check electric PTO clutch adjustment †Torque wheel lug nuts					
Service the air cleaner if indicator shows red Replace the fuel filter Check front transaxle oil level Check rear axle oil level (4-wheel drive) Inspect fuel lines and connections ‡Check engine rpm (idle and full throttle)					
†Inspect engine fan belt Inspect engine timing belt (see note below) Drain and clean the fuel tank Change hydraulic oil †Change hydraulic oil filter Change front transaxle oil Pack the rear axle bearings (2-wheel drive) Change rear axle oil (4-wheel drive) Change bi-directional clutch fluid (4-wheel drive) Check rear wheel toe-in					
† Initial break in at 10 hours ‡ Initial break in at 50 hours					
Replace moving hydraulic hoses Replace safety switches Flush the cooling system and replace fluid Replace PTO belts/cutter deck belts	<p style="text-align: center;">Recommendations: Items are recommended every 1500 hours or two years, whichever occurs first.</p>				

NOTE: Replace the timing belt, if worn, cracked or oil soaked. A new timing belt should be installed any time the belt is removed or loosened.

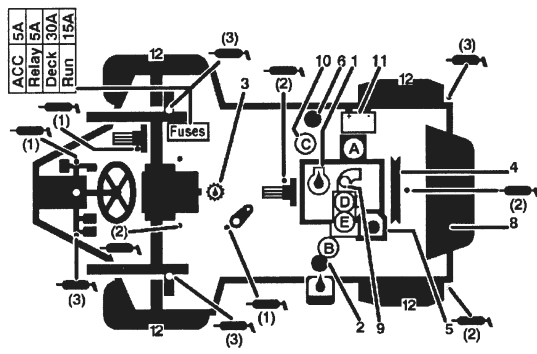

2-Wheel Drive

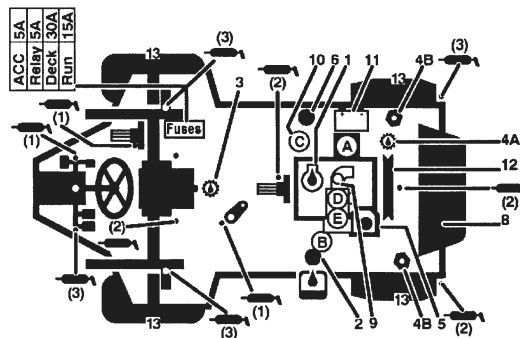

4-Wheel Drive

CHECK/FILL

1. Engine oil level/fill
2. Hydraulic oil level/fill
3. Front axle oil level/fill
4. Rear axle oil level
 - A. Fill
 - B. Check (2)
5. Coolant level/fill
6. Fuel diesel only
7. Grease points (23)
8. Radiator screen
9. Air filter service indicator
10. Water separator/fuel filter
11. Battery
12. Tire pressure

1. Engine oil level/fill
2. Hydraulic oil level/fill
3. Front axle oil level/fill
4. Rear axle oil level
 - A. Fill
 - B. Check (2)
5. Coolant level/fill
6. Fuel diesel only
7. Grease points (23)
8. Radiator screen
9. Air filter service indicator
10. Water separator/fuel filter
11. Battery
12. Fan belt
13. Tire pressure

	Fluid Type	Capacity	Change Interval		Filter Part. No.
			Fluid	Filter	
Engine oil	SAE 15W-40 CD	5 L	100 hours	100 hours	74-7970 (A)
Hydraulic circuit oil	Mobil DTE 15 M	24.6 L	800 hours	800 hours	86-3010 (B)
Axle oil	SAE 80-90 E.P.		800 hours		
Fuel filter				400 hours	76-5220 (C)
Primary air filter				See service indicator	93-9162 (D)
Safety air filter				See operator's manual	93-9163 (E)
Fuel	>0° C No. 2-D	53 L	Drain and flush, 800 hours		
	<0° C No. 1-D				
Coolant	93-7213 50/50 Peugeot Anti-Freeze	13.25 L	Drain and flush, 1500 hours or two years, whichever occurs first		

Greasing (Fig. 23–35)

The traction and cutting units have grease fittings that must be lubricated regularly with No. 2 General Purpose Lithium Base Grease. If the machine is operated under normal conditions, lubricate all grease fittings after every 25 hours of operation. Lubricate all grease fittings immediately after every washing, regardless of interval listed.

The grease fittings that must be lubricated are: Lift arm pivot (2), lift cylinder (2), brake arm pivots (2) (Fig. 23); brake pivot (1), brake pivots (2) (Fig. 24); traction pedal pivot (1) (Fig. 25); engine to pump drive shaft (2) (Fig. 26 & 27); traction adjuster (1) (Fig. 28); P.T.O. Bearing (Fig. 29).

2-Wheel drive machines only—cylinder end (2) center pivot (1), spindles (2) (Fig. 30).

4-Wheel drive machines only—tie rod assemblies (2), center pivot (1), axle knuckles (2) (Fig. 31); cylinder ends (2) (Fig. 32).

Cutting deck (2- & 4-wheel drive machines)—blade spindles (7) and Wing Deck Pivot pins (4) (Fig. 33); castor wheels (6); Castor fork shaft (4) (Fig. 34); Lift arm ball joints (2) and PTO to gear box drive shaft assembly (3) (Fig. 37).

1. Wipe grease fittings clean before lubricating.
2. Pump grease into fitting.
3. Wipe up excess grease.

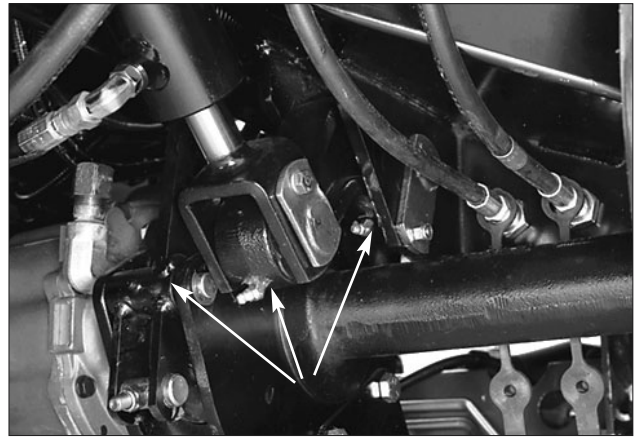

Figure 23

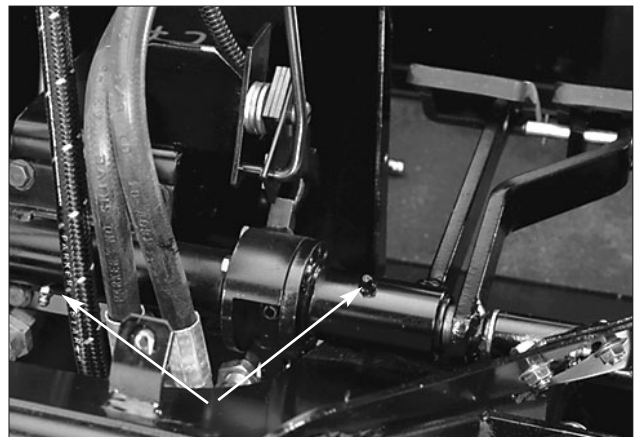

Figure 24

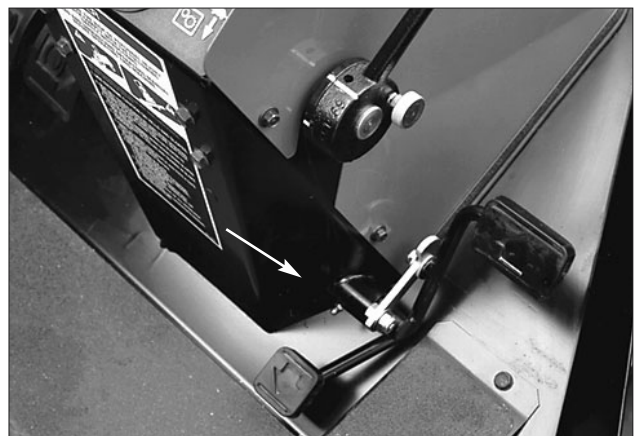

Figure 25

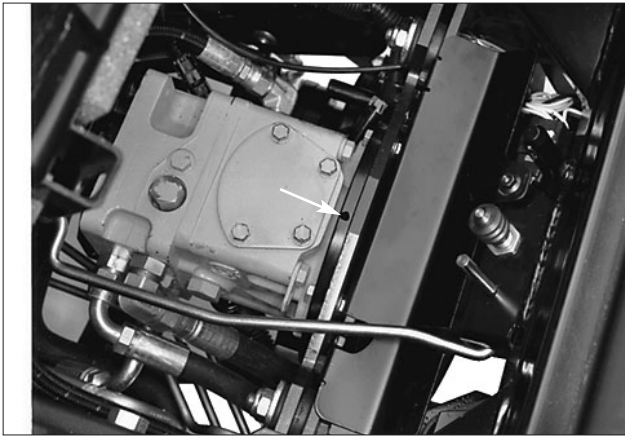

Figure 26

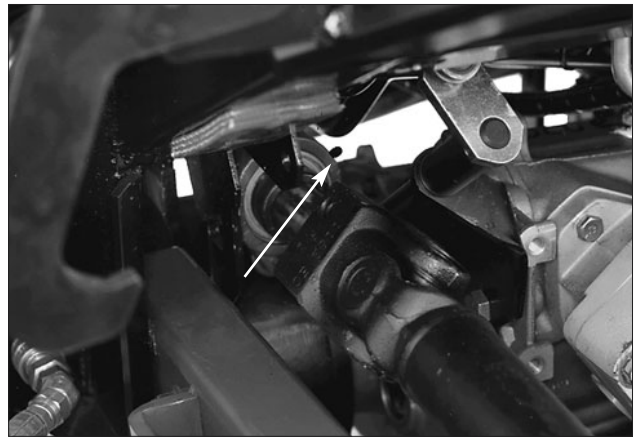

Figure 29



Figure 27



Figure 30

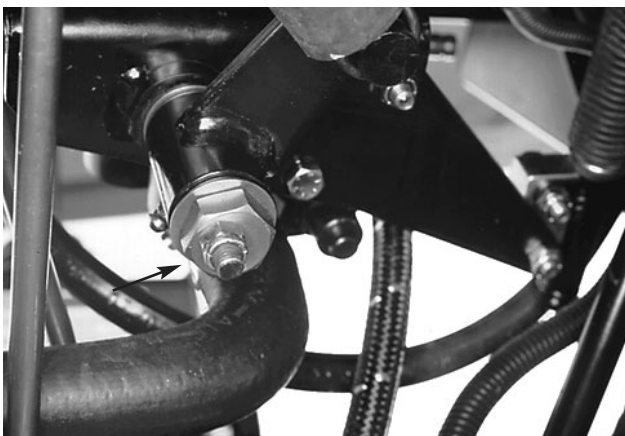

Figure 28



Figure 31



Figure 32



Fig. 35

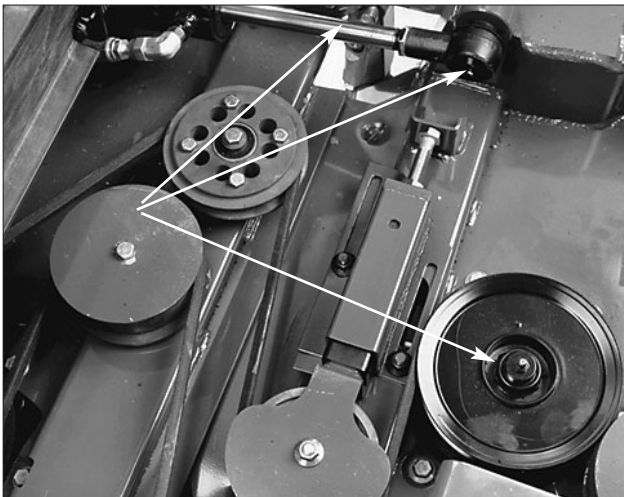

Fig. 33

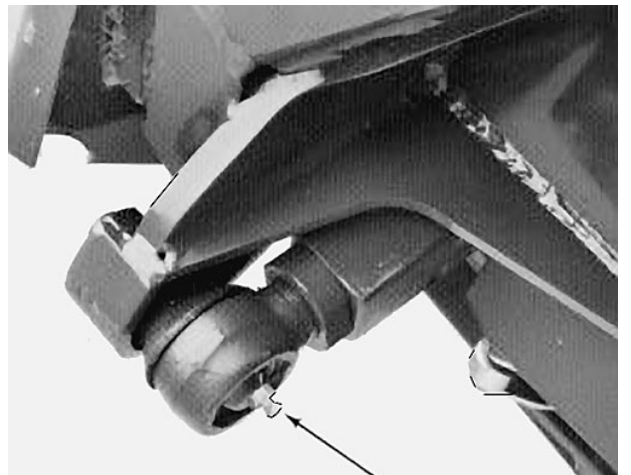

Fig. 36



Fig. 34

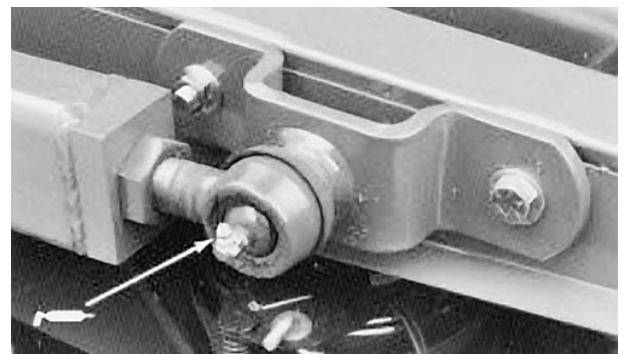

Fig. 37

General Air Cleaner Maintenance



WARNING



Before servicing or making adjustments to the machine, stop engine and remove key from the switch.

1. Check air cleaner body for damage that could possibly cause an air leak. Replace a damaged air cleaner body.
2. Service the air cleaner filters whenever air cleaner indicator (Fig. 38) shows red or every 400 hours (more frequently in extreme dusty or dirty conditions). Do not over-service the air filter.

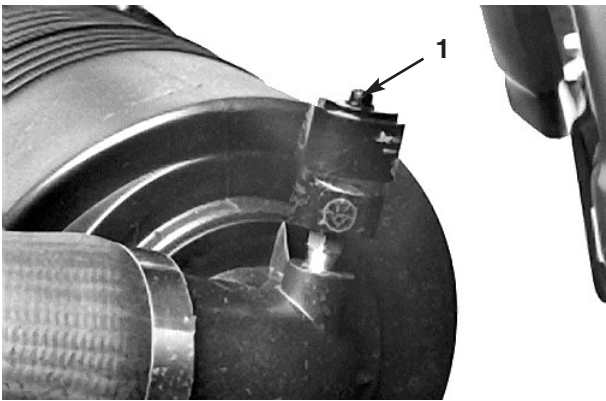

Figure 38

1. Air cleaner indicator

3. Be sure the cover is sealing around the air cleaner body.

Servicing the Air Cleaner

1. Release the latches securing the air cleaner cover to the air cleaner body. Separate the cover from the body. Clean inside of the air cleaner cover.
2. Gently slide the primary filter (Fig. 40) out of the air cleaner body to reduce the amount of dust dislodged. Avoid knocking the filter against the air cleaner body. Do not remove the safety filter.

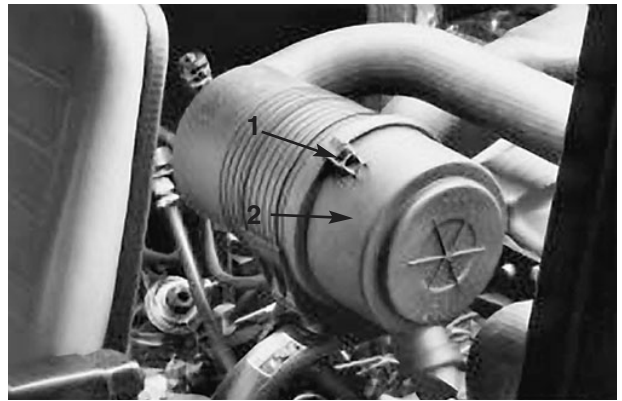

Figure 39

1. Air cleaner latches
2. Dust cup

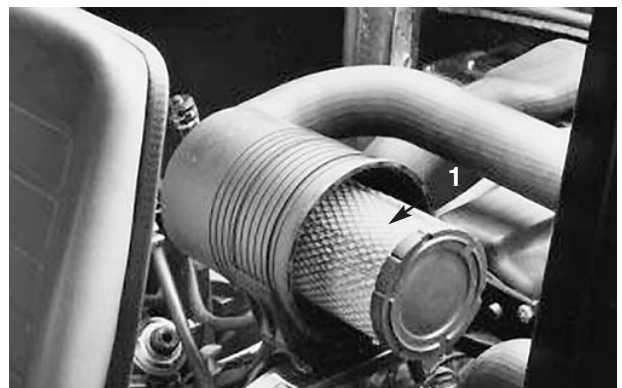

Figure 40

1. Air cleaner primary filter

3. Inspect the primary filter and discard if damaged. Do not wash or reuse a damaged filter.

IMPORTANT: Never attempt to clean a safety filter (located inside the primary filter). Replace the safety filter with a new one after every three primary filter services.

Washing Method

- A. Prepare a solution of filter cleaner and water and soak the filter element for about 15 minutes. Refer to directions on the filter cleaner carton for complete information.
- B. After soaking filter for 15 minutes, rinse it with clear water. Maximum water pressure must not exceed 276kPa (40 psi) to prevent damage to the filter element. Rinse the filter from the clean side to the dirty side.
- C. Dry the filter element using warm, flowing air 71°

C (160°F) max), or allow the element to air dry. Do not use a light bulb to dry the filter element because damage could result.

Compressed Air Method

- A. Blow compressed air from inside to the outside of dry filter element. Do not exceed 689 kPa (100 psi) to prevent damage to the element.
- B. Keep the air hose nozzle at least 5cm from the filter and move the nozzle up and down while rotating the filter element. Inspect for holes and tears by looking through the filter toward a bright light.
5. Inspect the new filter for shipping damage. Check the sealing end of the filter. Do not install a damaged filter.
6. Insert the new filter properly into the air cleaner body. Make sure the filter is sealed proper by applying pressure to the outer rim of the filter when installing it. Do not press on the flexible center of the filter.
7. Reinstall the cover and secure the latches. Make sure the cover is positioned with the TOP side up.
8. Reset the indicator (Fig. 38) if it is still showing red.

Engine Oil and Filter

Change the oil and filter initially after the first 50 hours of operation, thereafter change the oil and filter every 100 hours.

1. Remove the drain plug (Fig. 41) and let oil flow into drain the pan. When oil stops flowing, install the drain plug and a new plug seal.
2. Remove the oil filter (Fig. 42). Apply a light coat of clean oil to the new filter seal before screwing it on. **DO NOT OVER-TIGHTEN.**

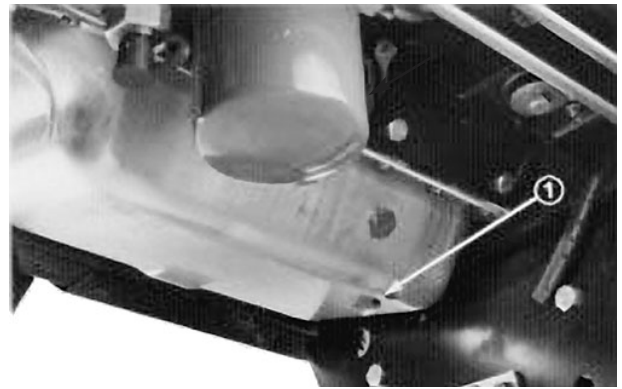

Figure 41

1. Drain plug

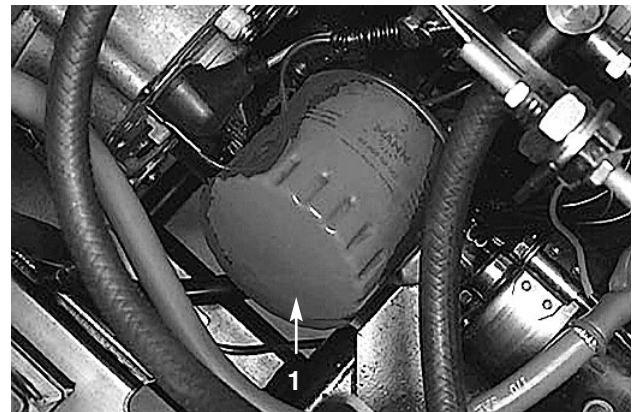

Figure 42

1. Oil filter

3. Add 15W-40 CD oil to the crankcase. Capacity is 5.0 l quarts with filter.

Fuel System

Fuel Tank



DANGER



Because diesel fuel is highly flammable, use caution when storing or handling it. Do not smoke while filling the fuel tank. Do not fill fuel tank while engine is running, hot, or when the machine is in an enclosed area. Always fill the fuel tank outside and wipe up any spilled diesel fuel before starting the engine. Store fuel in a clean, safety-approved container and keep the cap in place. Use diesel fuel for the engine only; not for any other purpose.

Drain and clean the fuel tank every 800 hours of operation or yearly, whichever comes first. Also, drain and clean the tank if the fuel system becomes contaminated or if the machine is to be stored for an extended period. Use clean fuel to flush out the tank.

Fuel Lines and Connections

Check lines and connections every 400 hours or yearly, whichever comes first. Inspect for deterioration, damage, or loose connections.

Draining Fuel Filter/Water Separator

Drain water or other contaminants from the fuel filter water separator daily.

1. Place a clean container under the fuel filter.

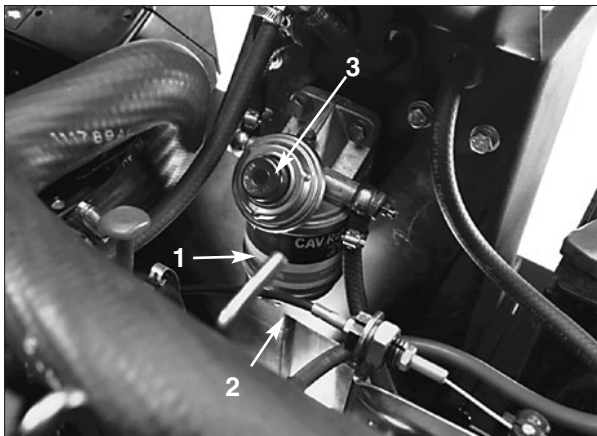

Figure 43

1. Fuel filter/water separator
2. Drain screw
3. Primer plunger

2. Loosen the drain thumb screw on the side of the fuel filter and press the primer plunger until only fuel is evident draining into container.
3. Tighten the drain screw.

Changing Fuel Filter

Replace fuel filter if fuel flow becomes restricted, after every 400 hours of operation or annually, whichever comes first.

1. Unscrew the bottom filter cap from the filter assembly. Remove the cap, gaskets, O-ring and

filter from the assembly. Note the position of the gaskets and O-ring when disassembling from the filter.

2. Install new filter, gaskets, O-ring with the filter assembly cap.
3. Prime the fuel system, refer to *Priming Fuel System*.

Engine Cooling System

1. **Removing Debris**—Remove debris from the rear screen, oil cooler and radiator daily, clean more frequently in dirty conditions. Use low-pressure compressed air.

IMPORTANT: Never spray water onto a hot engine or onto electrical connections as damage may occur.

- A. Turn the engine off, release the hood latch and raise the hood. Clean the engine area thoroughly of all debris. Close the hood.
- B. Unscrew the knobs and remove the rear screen (Fig. 44). Clean the screen thoroughly.

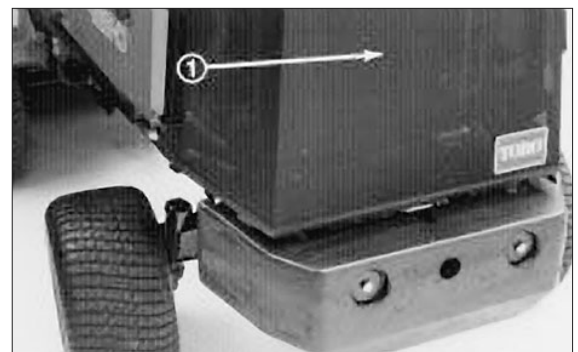

Figure 44

1. Rear screen

- C. Unscrew the knobs and pivot the oil cooler rearward.

Clean both sides of the oil cooler and radiator area thoroughly with low-pressure compressed air. Open the hood and blow debris out toward the back of the machine. Pivot the oil cooler back into position and tighten the knobs.

Note: The upper portion of the fan shroud may be easily unbolted from the machine to simplify cleaning.

- D. Install the rear screen and tighten the knobs.

IMPORTANT: Do not use water to clean the engine, as damage may occur.

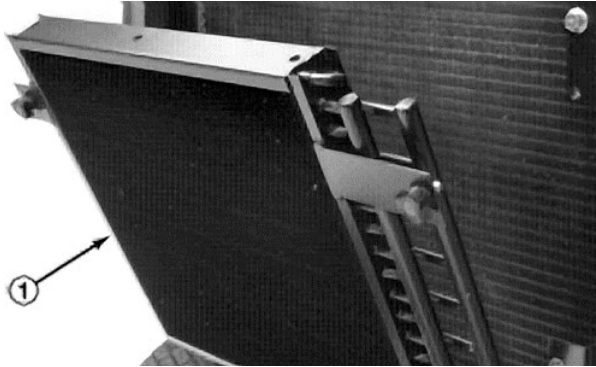

Figure 45

- 1. Oil cooler

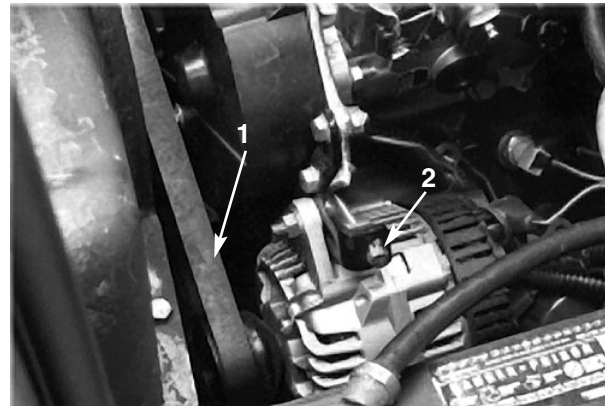

Figure 46

- 1. Fan belt
- 2. Adjusting screw

- 2. Maintaining Cooling System—Capacity of the system is 13 l (3.5 gal). Always protect the cooling system with a 50/50 solution of water and Peugeot recommended anti-freeze. **DO NOT USE WATER ONLY IN COOLING SYSTEM.**
 - A. After every 100 operating hours, tighten the hose connections. Replace any deteriorated hoses.
 - B. After every 2 years or 1500 hours, drain and flush the cooling system. Add anti-freeze (refer to Check Cooling System).

Engine Fan Belt

Check the condition and tension of fan the belt (Fig. 46) frequently. Inspect the belt every 800 hours of operation.

- 1. Proper tension will allow 6mm deflection on the belt midway between the pulleys, when pressed firmly with your thumb.
- 2. If deflection exceeds 6mm, loosen the alternator mounting bolts. Adjust alternator belt tension by adjusting the tension screw. Check deflection of the belt again to assure tension is correct.

Engine Timing Belt

Inspect the engine timing belt every 800 hours of operation or yearly.

- 1. Remove covers and check for a worn, cracked or oil-soaked belt.

Note: A new belt should be installed any time a belt is removed or loosened.

Changing Hydraulic Oil

Change the hydraulic oil filter initially after the first 50 hours of operation; thereafter change the hydraulic oil and filter after every 800 operating hours. If oil becomes contaminated, contact your local TORO distributor because the system must be flushed. Contaminated oil looks milky or black when compared to clean oil.

⚠WARNING⚠

Before servicing or making adjustments to the machine, stop engine and remove key from the switch.

- 1. Turn the engine off, release the hood latch and raise the hood.
- 2. Remove the drain plug from the rear of the reservoir and hydraulic line from front of reservoir (Fig. 47) and let hydraulic oil flow into the drain pan. Reinstall and tighten the plug and line when

hydraulic oil stops draining.

3. Fill the reservoir with approximately 24.6 l of hydraulic oil. Refer to *Check Hydraulic Circuit Oil*.

IMPORTANT. Use only hydraulic oils specified. Other fluids could cause system damage.

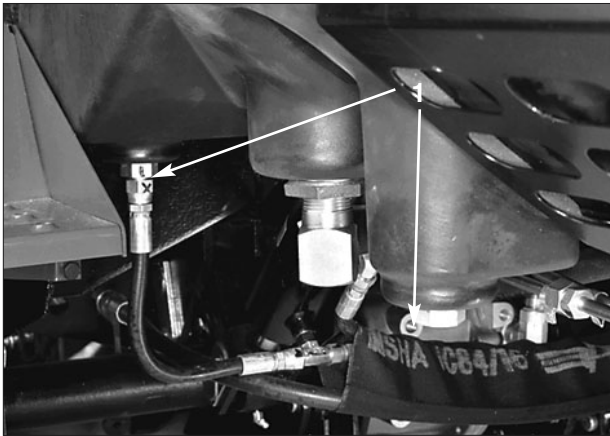

Figure 47

1. Hydraulic Reservoir Drain

4. Install the reservoir cap, lower the hood and latch. Start the engine and use all hydraulic controls to distribute hydraulic oil throughout the system. Also check for leaks. Then stop the engine.
5. With the wing decks raised, the center of the deck down and the oil warm, look into the sight gauge (Fig. 48). If hydraulic oil is not visible, add enough oil to raise the level to the middle (maximum) of the sight gauge. To prevent over filling, do not fill if oil is cold. **DO NOT OVER FILL.**

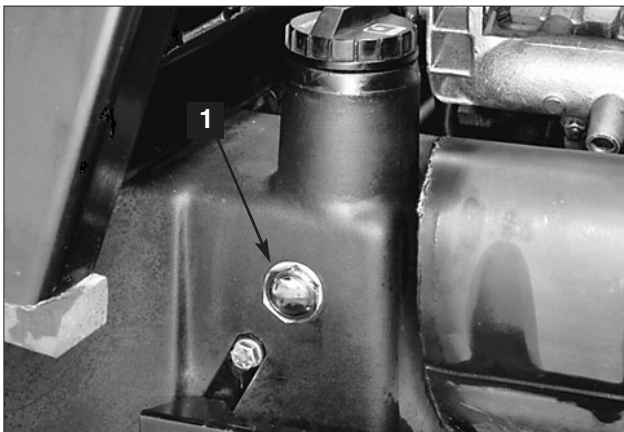

Figure 48

1. Sight gauge

Replacing the Hydraulic Filter

Initially, change the filter after the first 50 operating hours, thereafter, every 800 operating hours or annually, whichever comes first.

Only the Toro replacement filter (Part No. 86-301 0) can be used in the hydraulic system.

IMPORTANT: Use of any other filter may void the warranty on some components.

1. Turn the engine off, release the hood latch and raise the hood.
2. Clean the area around the filter mounting area (Fig. 49). Place a drain pan under the filter and remove the filter.

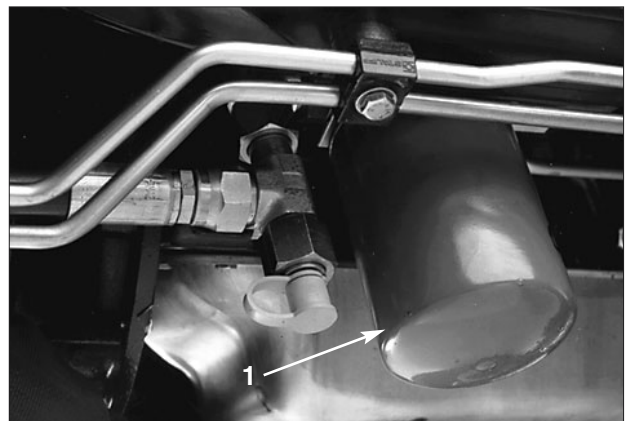



Figure 49

1. Hydraulic Filter

3. Lubricate the new filter gasket and fill the filter with hydraulic oil.
4. Assure the filter mounting area is clean. Screw the filter on until the gasket contacts the mounting plate. Then tighten the filter one-half turn.
5. Start the engine and let it run for about two minutes to purge air from the system. Stop the engine and check the oil level. Also check for any leaks.

Checking Hydraulic Lines and Hoses

Check hydraulic lines and hoses daily for leaks, kinked lines, loose mounting supports, wear, loose fittings, weather deterioration and chemical deterioration. Make all necessary repairs before operating.



WARNING



Keep body and hands away from pin-hole leaks or nozzles that eject high pressure hydraulic fluid. Use cardboard or paper to find hydraulic leaks. Hydraulic fluid escaping under pressure can penetrate skin and cause injury. Fluid accidentally injected into the skin must be surgically removed within a few hours by a doctor familiar with this form of injury or gangrene may result.

Hydraulic System Test Ports

The test ports are used to test the hydraulic circuits. Check all pressures when engine is at full speed and hydraulic oil is at normal operating temperature. Contact your local Toro distributor for assistance.

1. Traction Forward and Reverse have a normal relief setting of approximately 41,000 kPa (6000 psi).
2. Normal charge pressure is 689– 965 kPa (100–140 psi).

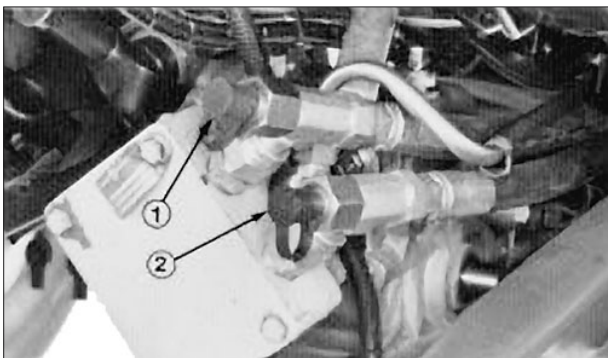

Figure 50

1. Traction forward circuit
2. Traction reverse circuit

3. Cutting unit counterbalance normal setting is approximately 4,100–4,400 kPa (600-650 psi) @ high idle and when oil is warm.

4. Lift circuit relief pressure is approximately 17,900–19,300 kPa (2600–2800 psi) when oil is warm.
5. The steering circuit has a normal relief setting of approximately 8,274 kPa (1200 psi) @ high idle and warm oil.
6. Wing deck cutting unit Counterbalance normal setting is approximately 2400–27—(350–400 psi) @ high idle and when oil is warm.

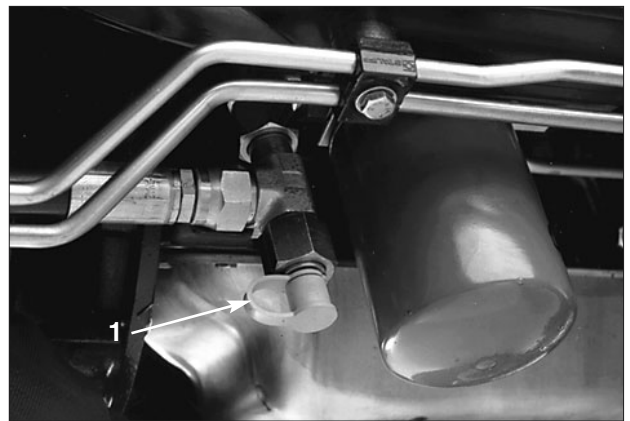

Figure 51

1. Charge pressure

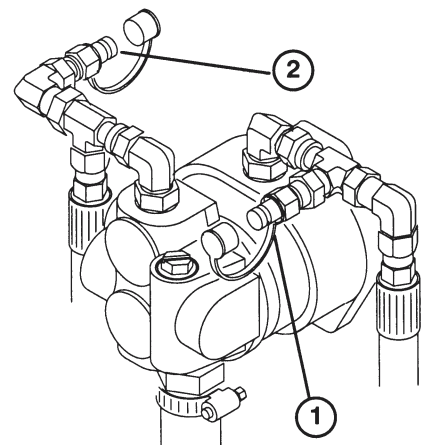

Figure 52

1. Counterbalance/Lift circuit
2. Steering circuit

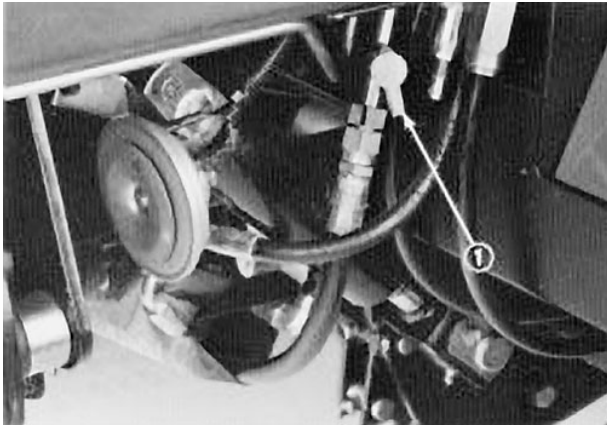

Figure 53

1. Counterbalance (wing decks)

Adjusting the Traction Drive For Neutral

The machine must not creep when the traction pedal is released. If it does creep, an adjustment is required.

1. Park the machine on a level surface, shut the engine off and move shift lever to HI. Depress only the left brake pedal and engage the parking brake.
2. Jack up the right side of the machine until the front tire is off the shop floor. Support the machine with jack stands to prevent it from falling accidentally.
3. Under the left side of the machine, loosen the locknut on the traction adjustment cam.

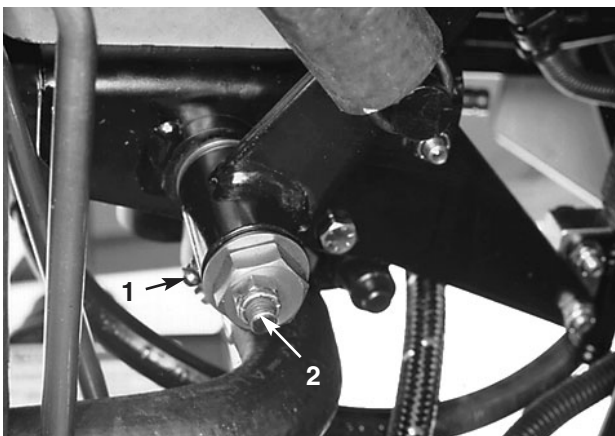

Figure 54

1. Traction adjustment cam
2. Locknut

4. Start the engine and rotate the cam hex in either direction until the wheel stops turning.

5. Tighten the locknut locking adjustment.
6. Stop the engine and release the right brake. Remove the jack stands and lower the machine to the shop floor. Test drive the machine to make sure it does not creep.



WARNING



The engine must be running so that final adjustment of the traction adjustment cam can be performed. To guard against possible personal injury, keep hands, feet, face and other parts of the body away from the muffler, other hot parts of the engine, and other rotating parts.

Changing Front Axle Lubricant

After every 800 hours of operation the oil in the front axle must be changed.

1. Position the machine on a level surface.
2. Clean the area around the drain plug (Fig. 55).

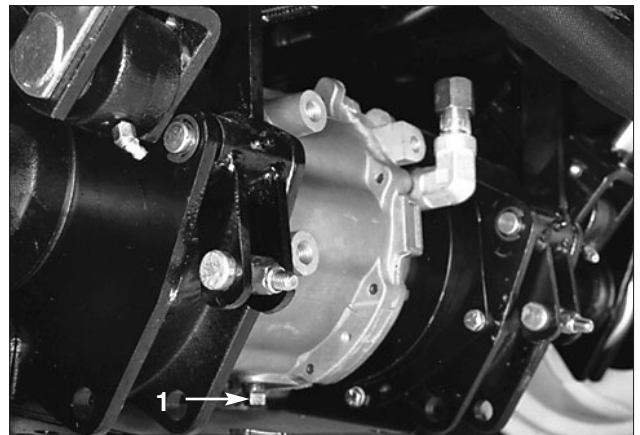

Figure 55

1. Front axle drain plug

3. Remove the plug, allowing oil to drain into a drain pan.
4. After oil is drained, reinstall the drain plug into the axle.
5. Fill the axle with lubricant; refer to *Check Front Axle Oil Level*.

Changing Rear Axle Lubricant

(Model 30455 only)

After every 800 hours of operation the oil in the rear axle must be changed.

1. Position the machine on a level surface.
2. Clean the area around the (3) drain plugs, (1) on each end and (1) in the center (Fig. 56).



Figure 56

1. Drain plugs (3)

3. Remove the plugs, allowing oil to drain into a drain pans.
4. **After the oil has drained, apply some thread-sealing compound on the drain plug threads and reinstall it into the axle.**
5. Fill the axle with lubricant; refer to *Check Rear Axle Lubricant*.

Changing Bi-Directional Clutch Lubricant (Model 30455 Only)

After every 800 hours of operation, the oil in the clutch housing must be changed.

1. Position the machine on a level surface.
2. Remove the drain plug from the clutch housing allowing fluid to drain into a drain pan.

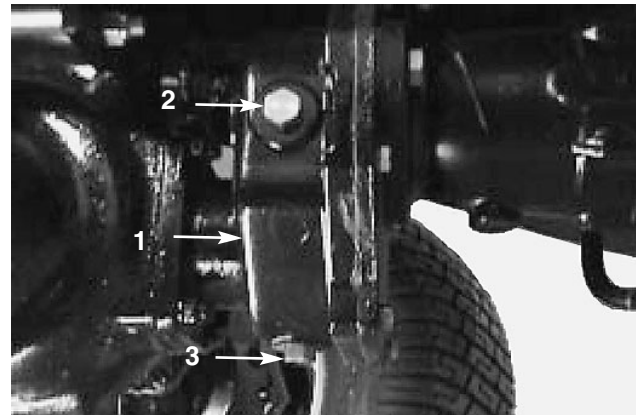

Figure 57

1. Clutch housing
2. Check/fill plug
3. Drain plug

3. After fluid has drained, reinstall the drain plug.
4. Remove check/fill plug and add 23.7 cl (8 oz.) of Mobil DTE 15 M anti-wear hydraulic fluid. **Note:** Do not use gear lube in clutch housing.
5. Install check/fill plug.

Rear Wheel Toe In

After every 800 operating hours or annually, check rear wheel toe-in.

1. Measure center-to-center distance (at axle height) at the front and rear of the steering tires. Front measurements must be within 3 mm of each other.



Figure 58

1. Tie rod clamps

2. To adjust 2-wheel drive models (Fig 58):

- A. Loosen the clamps at both ends of the tie rods.
 - B. Rotate the tie rod to move the front of the tire inward or outward.
 - C. Tighten the tie rod clamps when adjustment is correct.
3. To adjust 4-wheel drive models (Fig. 59):
- A. Remove the cotter pin and nut securing one of the tie rod ball joints to the steering arm. Remove the ball joint from the steering arm.
 - B. Loosen the clamp securing the ball joint to the tie rod.
 - C. rotate the ball joint one revolution and re-install it to the steering arm.
 - D. Inspect the toe-in and repeat adjustment if required.
 - E. Tighten the clamp securing the ball joint to the tie rod.
 - F. Torque the ball joint nut to 40 ft. lbs. and install the cotter pin.



Figure 59

- 1. Tie rod clamps

Adjusting Service Brakes (Fig. 60)

Adjust the service brakes when there is more than 38mm of "free travel" of the brake pedal, or when the brakes do not work effectively. Free travel is the distance the brake pedal moves before braking resistance is felt.

- 1. To reduce free travel of the brake pedals, tighten the nut on the brake rod adjuster, 1/2 turn at a time, until you achieve the desired "free play" in the

pedal.

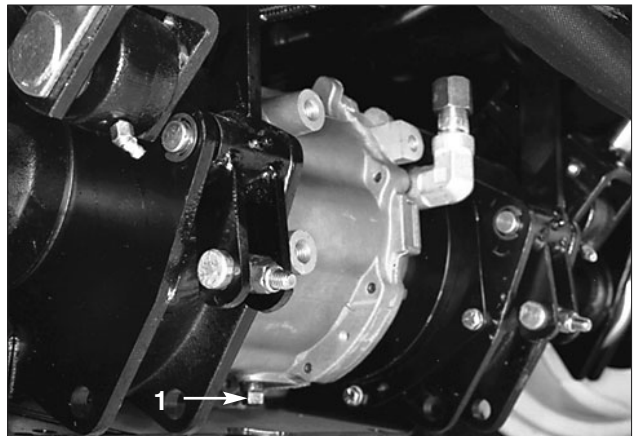

Figure 60

- 1. Brake rod adjuster

Adjusting Pro Belt (Fig. 61-62)

Re-tension the PTO belt (Fig. 61) initially after the first 10 hours of operation; thereafter, check condition and tension of belt every 100 hours. Replace the belt after every 1500 hours of operation.

- 1. Remove (2) screws securing the belt cover to the adapter plate and the screw the securing belt cover to the tab on the spring anchor. Remove the cover.

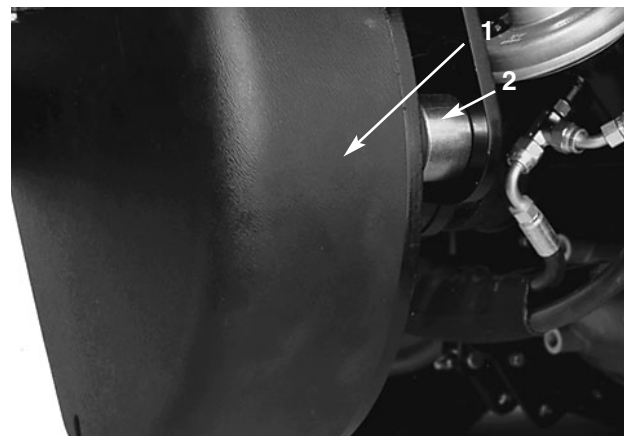

Figure 61

- 1. Belt cover
- 2. Adapter plate

- 2. Loosen the (3) flange screws and flange nuts securing the adapter plate to the clutch plate.
- 3. Insert the end of a 1/2 drive, 51cm long, torque wrench into square hole in clutch plate. With the wrench handle parallel to the ground, pull the wrench upward until 244Nm (180ft.-lbs.) of torque

is applied to the tension belt.

4. Tighten the flange screws and flange nuts.
5. Reinstall the belt cover with screws previously removed.

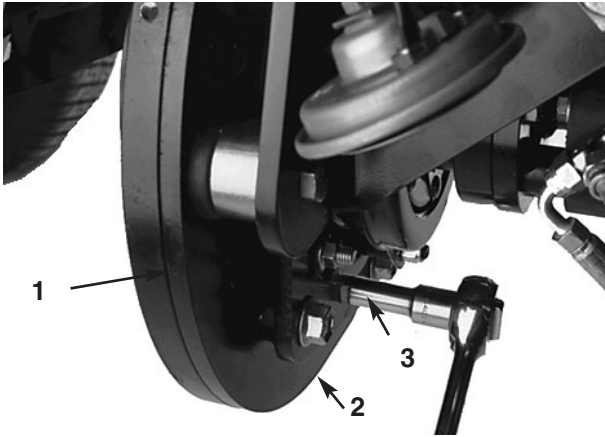

Figure 62

1. PTO belt
2. Adapter plate
3. Square hole

Adjusting the Clutch

The PTO clutch is adjustable to ensure proper engagement and blade braking. Check clutch adjustment initially after the first 10 hours of operation, thereafter, check every 200 hours.

1. To adjust the clutch, tighten or loosen the locknuts on the flange studs.
2. Check adjustment by inserting a feeler gauge through the slots next to the flange studs.
3. The proper disengaged clearance between the clutch plates is 0.2–0.5mm. It will be necessary to check this clearance at each of the three slots to ensure the plates are parallel to each other.

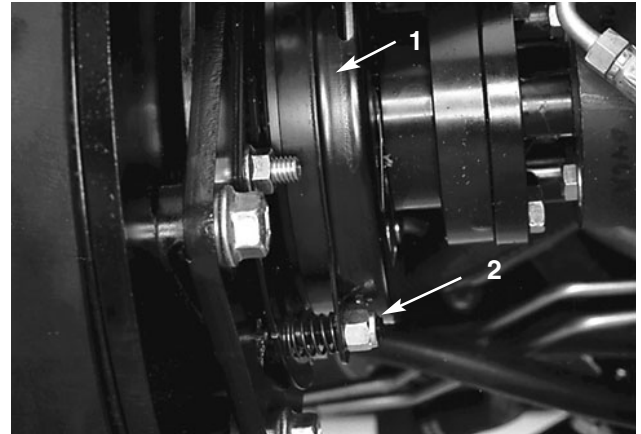

Figure 63

1. Clutch
2. Flange studs

Battery Care

IMPORTANT: Before welding on the machine, disconnect the ground cable from the battery to prevent damage to the electrical system.

Note: Check battery condition weekly or after every 100 hours of operation. Keep terminals and entire battery case clean because a dirty battery will discharge slowly. To clean the battery, wash the entire case with solution of baking soda and water. Rinse with clear water. Coat the battery posts and cable connectors with Grafo 11 2X (skin -over) grease (Toro Part No. 505-47) or petroleum jelly to prevent corrosion.

Fuses

There are 4 fuses in the machine's electrical system. They are located inside control panel.

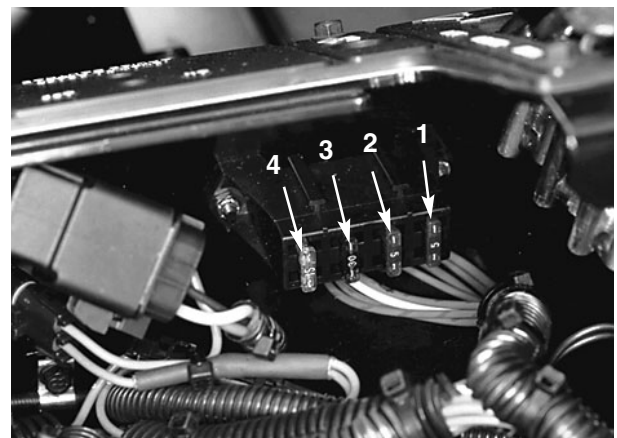

Figure 64

1. ACC fuse (5 amp)
2. Relay fuse (5 amp)
3. Deck fuse (30 amp)
4. Run fuse (15 amp)

Cutting Unit Maintenance



WARNING



To prevent the engine from starting accidentally while you are performing maintenance, shut the engine off and remove the key from the ignition switch.

General Maintenance

Note: Although not required for normal maintenance procedures, the cutting unit may be pivoted (tilted) to an upright position. Should you desire to tilt the cutting unit, use the following procedure:

To Pivot (Tilt) the Cutting Unit Upright:

1. Drive the machine onto ramps to raise the front of the machine.
2. Lower the center and wing cutting units to the ground; then raise the center cutting unit slightly, until the rear deck straps hang freely on the lift arm brackets. Stop the engine after the cutting unit is raised. Set the parking brake.
3. Disconnect the (3) hydraulic lines (quick couplers) and wire harness at the rear of the deck (Fig. 65).



Figure 65

1. Hydraulic line couplers
2. Wire harness
3. Rear deck straps

4. Remove the hairpin cotters and height-of-cut pins securing the rear deck straps to the height-of-cut brackets on the deck (Fig. 66).
5. Start the engine and lower the center cutting unit to the ground. Stop the engine after the cutting unit is lowered.



WARNING



Do not start the engine and engage the PTO switch when the PTO shaft is not connected to the gear box on the cutting unit. If engine is started and PTO shaft is allowed to rotate, serious injury could result.

6. Remove the socket head screws securing the drive shaft yoke to the gear box input shaft. Slide the yoke off the shaft (Fig. 66).

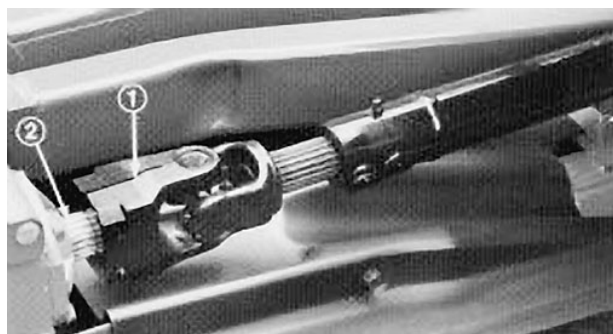

Figure 66

1. Drive shaft yoke
2. Gear box input shaft

7. Sit on the seat, start the engine and slowly raise the center cutting unit, allowing the cutting unit to pivot upright. Stop the engine and remove the key from the ignition switch.

To Pivot the Cutting Unit Down into Operating Position:

1. Sit on seat, start the engine and slowly lower the cutting units to the ground; then raise the center cutting unit slightly, so the rear deck straps can be mounted to the lift arm brackets. Stop the engine after the cutting unit is raised. Set the parking brake.
2. Line up the holes in the yoke and the input shaft of the gear box. Slide the yoke onto the shaft and secure them together with socket head screws. Torque the screws to 27–34 Nm (20–25 ft-lb.).
3. Secure the rear deck straps to the height-of-cut brackets on the deck with hair pin cotters and height-of-cut pins. Start the engine and lower the center cutting unit completely to the floor. Assure

all lift levers are in the float position and stop the engine.

4. Connect the wire harness and (3) hydraulic lines couplers at the rear of the deck.

Separating the Cutting Unit From the Traction Unit

1. Lower the center and wing cutting units to the ground; then raise the center cutting unit slightly, until the rear deck straps hang freely on the lift arm brackets. Stop the engine after the cutting unit is raised. Set the parking brake.
2. Remove the hairpin cotters and height-of-cut pins securing the rear deck straps to the height-of-cut brackets on the deck. Start the engine and lower the center cutting unit completely to the floor. Stop the engine after the cutting unit is lowered.
3. Disconnect the (3) hydraulic lines (quick couplers) and the wire harness at the rear of the deck.
4. Remove the socket head screws securing the drive shaft yoke to the gear box input shaft. Slide the yoke off the shaft.
5. Remove the (4) capscrews, flatwashers and flange nuts securing the ball joint mounts to the castor arms on the cutting unit.

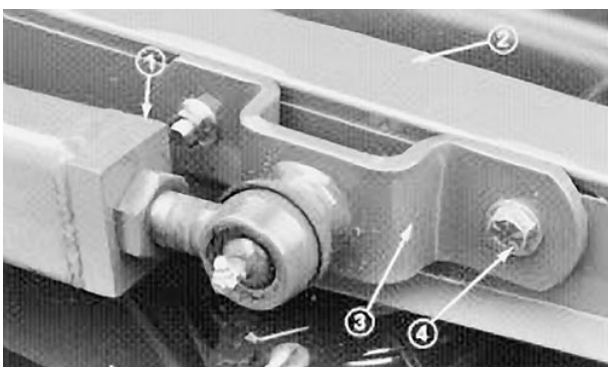

Figure 67

1. Push arm
2. Castor arm
3. Ball joint mount
4. Capscrews & washers

6. Roll the cutting unit away from the traction unit.

Alternate Method

1. Lower the center and wing cutting units to the ground, set the parking brake and stop the engine.
2. Disconnect (3) hydraulic lines (quick couplers) and wire harness at the rear of the deck.
3. Remove the socket head screws securing the drive shaft yoke to the gear box input shaft. Slide the yoke off the shaft.
4. Remove (2) capscrews and locknuts securing the cutting unit carrier frames to the traction unit lift arms (Fig. 68).

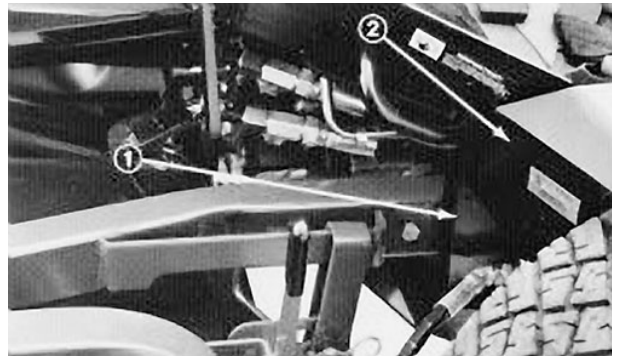

Figure 68

1. Cutting unit carrier frames
2. Traction unit lift arms

5. Slowly back the traction unit away from the cutting unit.

Mounting the Cutting Unit to the Traction Unit

1. With the cutting unit on a level surface, move the traction unit into position, aligning the drive shaft yoke with the gear box input shaft and lift the arm ball joints with the mounting holes in the castor arms. Shut the engine off.
2. Secure the ball joint mounts to the castor arms with capscrews, flatwashers and flange nuts. Tighten the capscrews and flange nuts to 136–149 Nm (100–110 ft-lb.).
3. Line up the holes in the yoke and the input shaft of the gear box. Slide the yoke onto the shaft and secure them together with socket head screws.

Torque the screws to 27–34 Nm (20–25 ft-lb.).

4. Start the engine, raise the center cutting unit slightly so that the rear deck straps can be mounted on the lift arm brackets. Stop the engine after the cutting unit is raised.
5. Secure the rear deck straps to height-of-cut brackets on the deck with hair pin cotters and height-of-cut pins. Start the engine and lower the center cutting unit completely to the floor. Assure all lift levers are in the float position and stop the engine.
6. Connect the wire harness and (3) hydraulic lines couplers at the rear of the deck.

Safety Door Adjustment

On each side of the center deck is a safety door that opens and closes as the wing decks are lowered and raised (Fig. 68). The doors open to provide overlap of the cutting blades when the wing units are down. The doors close to provide safety and protection when the wing units are raised. Check to make sure the forward, lower edge of the door (Fig. 68) is even or 6mm higher than the lower edge of the door guide when the wing decks are in the fully raised, transport position. If an adjustment to the door is required, proceed as follows:

1. Loosen the jam nuts securing the ball joints to a threaded rod.

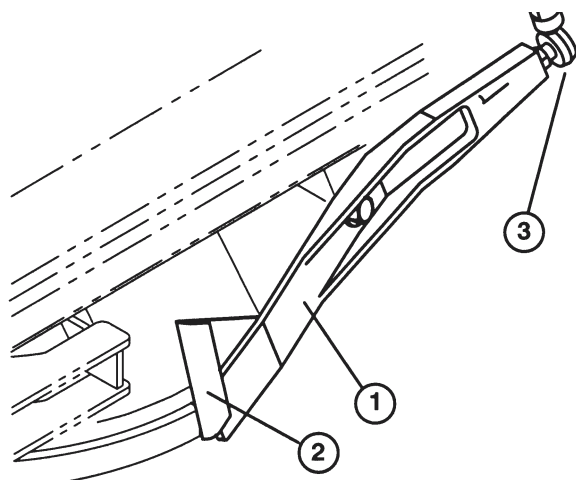

Figure 69

1. Safety door
2. Door guide
3. Ball joint

2. Rotate the threaded rod to raise or lower the edge of the door until it is even or 6mm higher than the lower edge of the door guide when wing decks are in the fully raised, transport position.



CAUTION



Check for proper operation of the safety doors each time the deck is cleaned and repair as needed.

3. Tighten the jams nuts to lock adjustment.

Blade Adjustment

To assure proper operation of the cutting unit, there must be 6mm \pm 3mm clearance between the tips of the wing and the center cutting unit blades.

1. Raise the cutting unit so blades are visible and block the center deck section so that it cannot fall accidentally. The wing decks must be horizontal to the center cutting unit.
2. Rotate a center and adjoining wing blade so their blade tips are aligned. Measure the distance between blade tips. The distance should be approximately 6mm \pm 3mm.

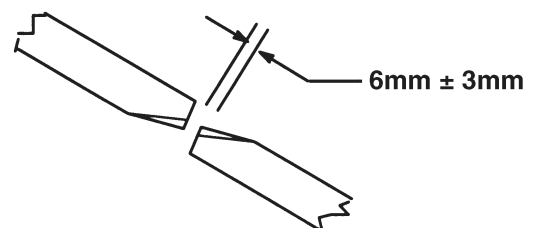

Figure 70

3. To adjust distance, locate the adjuster bolt on the rear outside corner of center cutting unit. Loosen the jam nut on the adjuster bolt. Loosen or tighten the adjuster bolts until a 6mm \pm 3mm clearance is attained, then tighten the jam nut.
4. Repeat the procedure on the opposite side of the cutting deck.

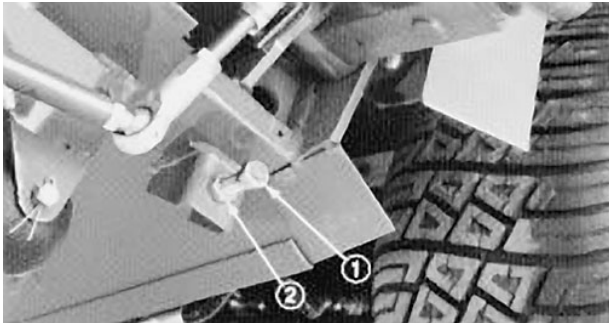

Figure 71

1. Adjuster bolt
2. Jam nut

IMPORTANT: The blade plane is adjusted at the factory and should not need further adjustment.

Adjusting Belt Tension

Each cutting unit drive belt is individually tensioned by a self-tensioning, spring-loaded idler. When the idlers are properly adjusted, the black plastic sleeve should be flush (even) with the edge of the idler support. When 12mm of the plastic sleeve is exposed, an adjustment is required. To assure proper operation of the cutting unit, check the adjustment of the spring loaded idler after the first 10 hours of operation and every time maintenance on the belt is required.

1. Lower the cutting unit to the shop floor. Remove the belt covers from the center and wing cutting units.
2. Measure the length of the exposed black plastic sleeve. If the distance is 0–12mm, the spring-loaded idler is properly adjusted and belt tension is correct. If the dimension is not correct, go to the next step.

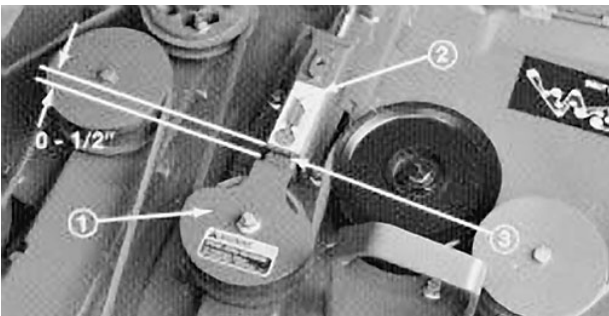

Figure 72

1. Spring-loaded idler
2. Idler support
3. Black plastic sleeve

3. Loosen the (2) flange head nuts securing the idler

adjustor tube to top of the cutting deck.

4. Loosen the jam nut on the adjusting screw and turn the screw until the black plastic sleeve is flush (even) with the edge of the idler support.
5. When distance is attained, tighten the jam nut on the adjusting screw and (2) flange head nuts securing the idler adjustor tube to the top of the cutting deck.
6. Check adjustment on the other adjustors and repeat procedure if required.

Replacing Drive Belts

The blade drive belts are very durable, but after many hours of use, the belts will show signs of wear. Signs of a worn belt are: squealing when the belt is rotating, blades slipping when cutting grass, frayed edges, burn marks and cracks. Replace a belt if any of these conditions are evident.

1. Lower the cutting unit to the shop floor. Remove the belt covers from the center and wing cutting units.

To Remove Wing Deck Belts

	WARNING	
The idler pulley spring is loaded; use caution when relieving spring tension on the wing belt.		

2. To relieve tension on the wing belt, pull back on idler pulley until the holes in idler adjustor tube and the tube sleeve are aligned. Thread a 5/16-18 capscrew into the holes' retaining parts.

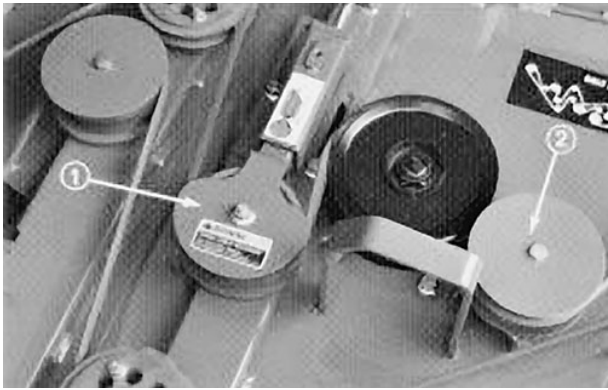

Figure 73

1. Spring-loaded idler pulley
2. Stationary idler pulley

3. Remove the hair pin cotter securing the clutch rod to the front of the cutting deck and disconnect the rod from the deck. Unplug the clutch wire from the harness.
4. To ease wing belt removal, loosen or remove the stationary idler pulley next to the wing's inner spindle pulley.

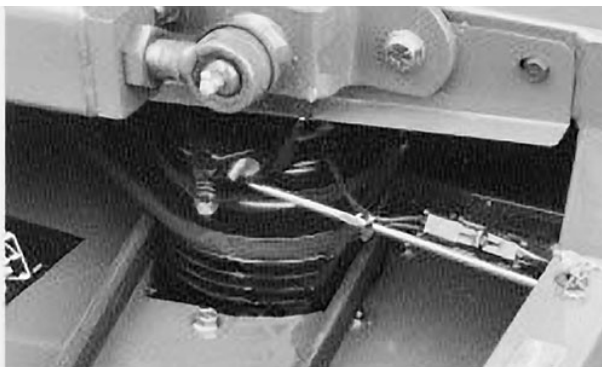

Figure 74

1. Clutch rod
2. Clutch wire

To Remove the Center Deck Belt

5. To relieve tension on the center deck belt, pull back on the idler pulley until the holes in the idler adjuster tube and the tube sleeve are aligned. Thread a 5/16-18 capscrew into the holes' retaining parts.
6. Wing deck belts must be removed before the center deck belt can be removed, repeat steps 1–3.
7. Remove (2) flange head screws securing the drive shaft cover to the gear box support and remove the cover.

8. Remove the capscrews and nuts securing the front of the gear box support to the deck channels and loosen the capscrews securing the rear of the gear box support to the deck channels.

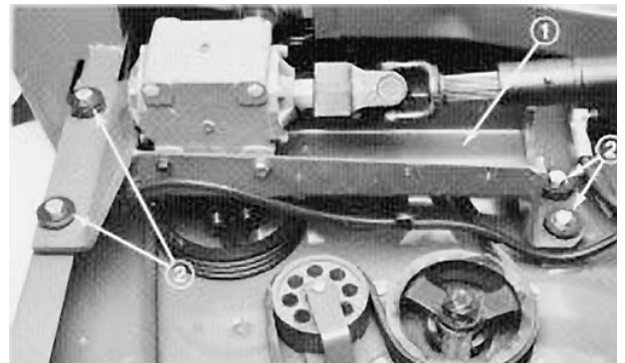

Figure 75

1. Gear box support
2. Capscrews & nuts

9. Raise the front of gearbox support and remove the old belt from around the gear box pulley and remaining pulleys.
10. Route the new belt around the appropriate pulleys as shown in figure 76.

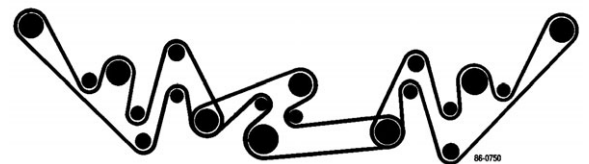

Figure 76
Belt Routing

11. Remount the gear box support to the deck channels with the capscrews and nuts you previously removed.
12. Reinstall the drive shaft cover to the gear box support with the (4) flange head screws you previously removed.
13. Remount the clutch rod to the deck with a hair pin cotter and plug the clutch connector into the harness.
14. While holding the idler pulley adjuster in position, carefully remove the capscrew securing the idler adjuster tube to the tube sleeve. Allow the idler pulley to release, tensioning the belt.

15. Check the idler pulley adjustment, refer to *Adjusting Belt Tension*.

16. Reinstall the belt covers.

Adjusting the Belt Clutch (Fig. 77)

The deck clutches are adjustable to ensure proper engagement and blade braking. Check clutch adjustment after the first 50 hours of operation; thereafter, every 200 hours. Adjust if required.

1. To adjust the clutch, tighten or loosen the locknuts on flange studs.
2. Check adjustment by inserting a feeler gauge through the slots next to the flange studs.
3. The correct disengaged clearance between the clutch plates is 0.28–0.3mm. It will be necessary to check this clearance at each of the three slots to ensure the plates are parallel to each other.

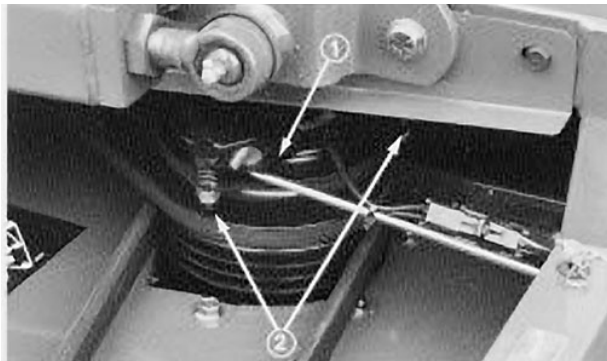

Figure 77

1. Clutch
2. Flange studs

the top of the castor spindle.

3. Pull the castor spindle out of the mounting tube. Allow spacer(s) to remain on the bottom of the spindle.
4. Insert a pin punch into the top or bottom of the mounting tube and drive the bushing out of tube. Also drive the other bushing out of the tube. Clean inside tubes to remove dirt.
5. Apply grease to the inside and outside of new bushings. Using a hammer and flat plate, drive the bushings into the mounting tube.
6. Inspect the castor spindle for wear and replace it if damaged.
7. Push the castor spindle through the bushings and mounting tube. Slide the spacer(s) onto the spindle. Install the height-of-cut cap on the castor spindle to retain all parts in place.

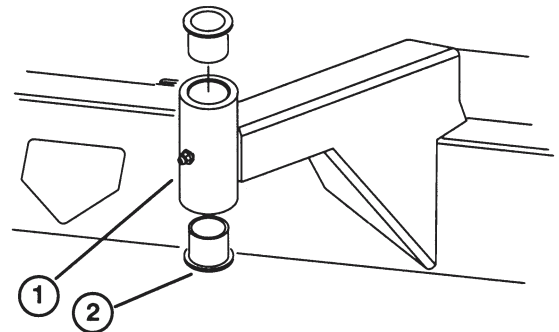

Figure 78

1. Front castor arm tube
2. Bushings

Servicing Front Bushings In Castor Arms

The castor arms have bushings pressed into the top and bottom of the tube. After many hours of operation, the bushings will wear. To check the bushings, move the castor fork back and forth and from side to side. If the castor spindle is loose inside the bushings, bushings are worn and must be replaced.

1. Raise the cutting unit so the wheels are off the floor and block it so that it cannot fall accidentally.
2. Remove the height-of-cut cap and spacer(s) from

Servicing Castor Wheels And Bearings

1. Remove the locknut from the capscrew holding the castor wheel assembly between front castor fork (Fig. 79) or rear castor pivot arm (Fig. 80). Grasp the castor wheel and slide the capscrew out of the fork or pivot arm.

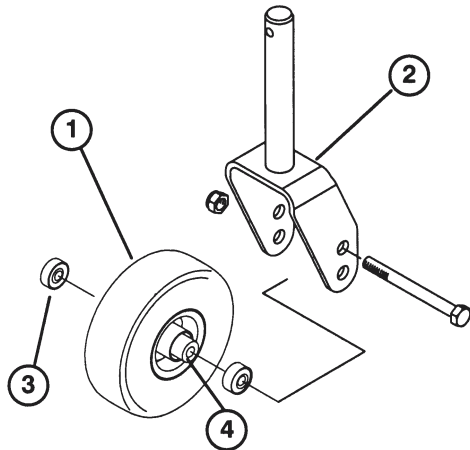

Figure 79

- 1. Castor wheel
- 2. Front castor fork
- 3. Bearing (2)
- 4. Bearing spacer

2. Remove the bearing from the wheel hub and let the bearing spacer fall out. Remove the bearing from the opposite side of the wheel hub.
3. Check the bearings, spacer and inside of wheel hub for wear. Replace defective parts.
4. To assemble the castor wheel, push the bearing into the wheel hub. Slide bearing spacer into wheel hub. Push the other bearing into the open end of the wheel hub to captivate the bearing spacer inside the wheel hub.
5. Install the castor wheel assembly between the castor fork and secure it in place with a cap screw and locknut.

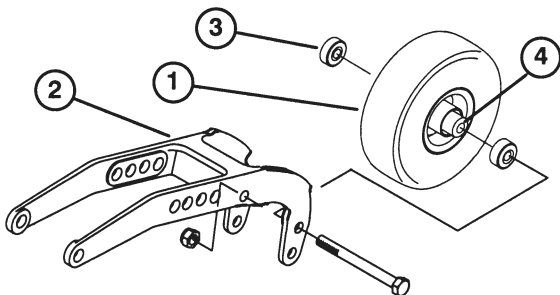

Figure 80

- 1. Castor wheel
- 2. Rear castor pivot arm
- 3. Bearing (2)
- 4. Bearing spacer

Blade Removal And Installation

The blade must be replaced if a solid object is hit, the blade is out of balance, or if the blade is bent. Always use genuine TORO replacement blades to be sure of safety and optimum performance. Never use replacement blades made by other manufacturers because they could be dangerous.

! **WARNING** !

Do not try to straighten a blade that is bent, and never weld a broken or cracked blade. Always use a new blade to assure continued safety certification of the product.

1. Raise the cutting unit to the highest position, shut the engine off and engage the parking brake. Engage transport latches to prevent the cutting unit from falling accidentally.
2. Grasp the end of the blade using a cloth or thickly padded glove. Remove the blade bolt, anti-scalp cup and blade from the spindle shaft.
3. Install the blade-sail facing toward the cutting unit with the anti-scalp cup and blade bolt. Tighten the blade bolt to 115–149Nm (85–110 ft-lb.).

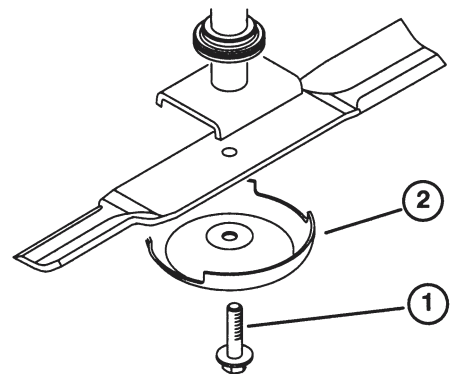

Figure 81

- 1. Blade bolt
- 2. Anti-scalp cup

Inspecting And Sharpening the Blade

1. Raise the cutting unit to the highest position, shut the engine off and engage the parking brake. Engage the transport latches to prevent the cutting unit from falling accidentally.
2. Examine the cutting ends of the blade carefully, especially where the flat and curved parts of the blade meet (Fig. 81-A). Since sand and abrasive material can wear away the metal that connects the flat and curved parts of the blade, check the blade before using the machine. If wear is noticed (Fig. 81-B), replace the blade: refer to *Blade Removal and Installation*.

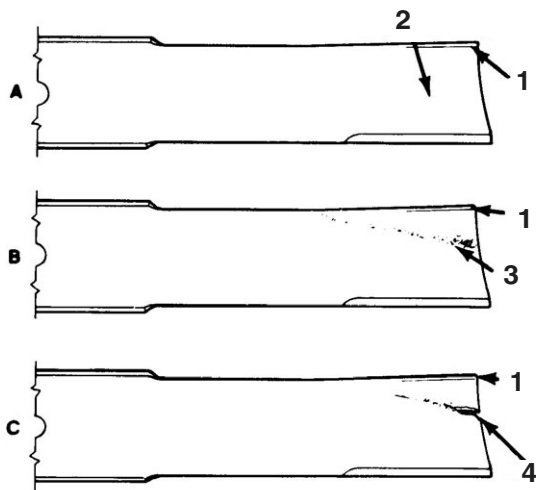

Figure 82

1. Sail
2. Flat part of blade
3. Wear
4. Slot formed

3. Inspect the cutting edges of all blades. Sharpen the cutting edges if they are dull or nicked. Sharpen only the top of the cutting edge and maintain the original cutting angle to make sure of sharpness (Fig. 83). The blade will remain balanced if same amount of metal is removed from both cutting edges.

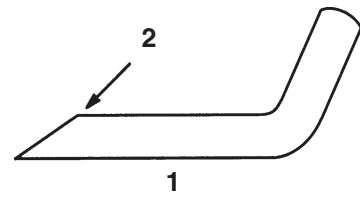

Figure 83

1. End view
2. Sharpen at this angle only

4. To check the blade for being straight and parallel, lay it on a level surface and check its ends. Blade ends must be slightly lower than the center, and the cutting edge must be lower than the heel of the blade. This blade will produce good quality of cut and require minimal power from the engine. By contrast a blade that is higher at the ends than the center, or if cutting edge is higher than the heel, the blade is bent or warped and must be replaced.
5. Install the lade-sail facing toward the cutting unit with the anti-scalp cup, lockwasher and blade bolt. Tighten the blade bolt to 115–149Nm (85-110 ft-lb.).

Preparation for Seasonal Storage

Traction Unit

1. Thoroughly clean the traction unit, cutting units and the engine.
2. Check the tire pressure. Inflate all tires to 138 kPa (20 psi).
3. Check all fasteners for looseness; tighten as necessary.
4. Grease or oil all grease fittings and pivot points. Wipe up any excess lubricant.
5. Lightly sand and use touch-up paint on painted areas that are scratched, chipped, or rusted. Repair any dents in the metal body.
6. Service the battery and cables as follows:
 - a. Remove the battery terminals from the battery posts.
 - b. Clean the battery, terminals, and posts with a wire brush and baking soda solution.
 - c. Coat the cable terminals and battery posts with Grafo 112X skin-over grease (Toro Part No. 505-47) or petroleum jelly to prevent corrosion.
 - d. Slowly recharge the battery every 60 days for 24 hours to prevent lead sulfation of the battery.
6. Flush the fuel tank with fresh, clean diesel fuel.
7. Resecure all fuel system fittings.
8. Thoroughly clean and service the air cleaner assembly.
9. Seal the air cleaner inlet and the exhaust outlet with weatherproof tape.
10. Check anti-freeze protection and add a 50/50 solution of water and Peugeot recommended anti-freeze (Toro part No. 93-7213) as needed for expected minimum temperature in your area.

Cutting Unit

1. Check blades and tighten blade bolts to 115–149Nm (85-110 ft-lb.).
 2. Check and lubricate caster arm bushings.
 3. Check and lubricate caster wheel bearings (if so equipped). Tighten caster wheel nuts to 190–224 kPa (140-165 ft-lb.).
 4. Check all fasteners for looseness; tighten as necessary.
 5. Grease or oil all grease fittings and pivot points. Wipe up any excess lubricant.
 6. Lightly sand and use touch-up paint on painted areas that are scratched, chipped, or rusted.
 7. Check and relieve tension on the drive belts.
 8. Clean thoroughly the top and underside.
 9. Store the machine with its wing decks lowered.
1. Drain the engine oil from the oil pan and replace the drain plug.
 2. Remove and discard the oil filter. Install a new oil filter.
 3. Refill the oil pan with 5 l of SAE15W-40 CD motor oil.
 4. Start the engine and run at idle speed for approximately two minutes.
 5. Stop the engine.