



Count on it.

Operator's Manual

Bagger Kit
Z Master® 4000 Series Riding Mower

Model No. 78463—Serial No. 40000000 and Up

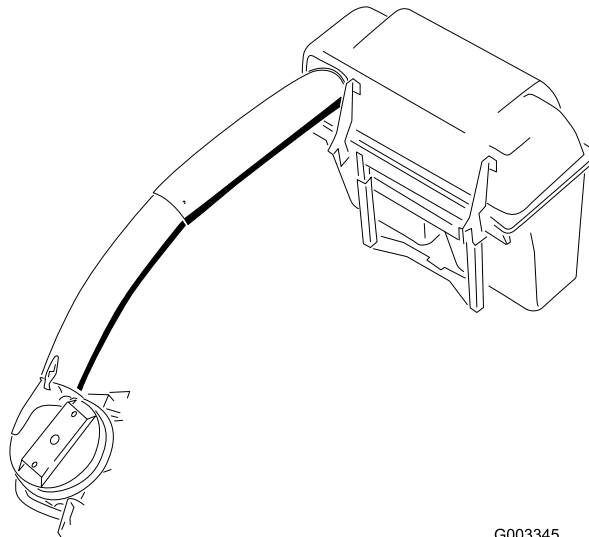

G003345



⚠ WARNING

**CALIFORNIA
Proposition 65 Warning**

Use of this product may cause exposure to chemicals known to the State of California to cause cancer, birth defects, or other reproductive harm.

Introduction

Read this information carefully to learn how to operate and maintain your product properly and to avoid injury and product damage. You are responsible for operating the product properly and safely.

Visit www.Toro.com for product safety and operation training materials, accessory information, help finding a dealer, or to register your product.

Whenever you need service, genuine Toro parts, or additional information, contact an Authorized Service Dealer or Toro Customer Service and have the model and serial numbers of your product ready. [Figure 1](#) and [Figure 2](#) identify the location of the model and serial numbers on the product. Write the numbers in the space provided.

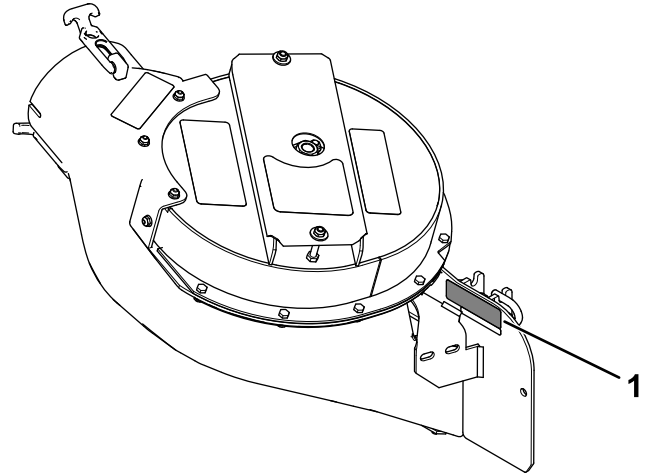

g341472

Figure 2

1. Blower model and serial number location

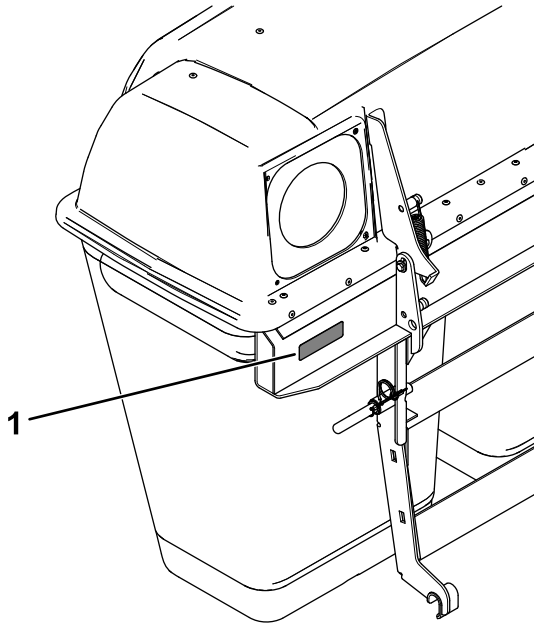

g341471

Figure 1

1. Bagger model and serial number location

Model No. _____
Serial No. _____

This manual uses 2 words to highlight information. **Important** calls attention to special mechanical information and **Note** emphasizes general information worthy of special attention.

The safety-alert symbol (Figure 3) appears both in this manual and on the machine to identify important safety messages that you must follow to avoid accidents. This symbol will appear with the word **Danger**, **Warning**, or **Caution**.

- **Danger** indicates an imminently hazardous situation which, if not avoided, **will** result in death or serious injury.
- **Warning** indicates a potentially hazardous situation which, if not avoided, **could** result in death or serious injury.
- **Caution** indicates a potentially hazardous situation which, if not avoided, **may** result in minor or moderate injury.



Figure 3

Safety-alert symbol

g000502

Contents

Safety	4
Safety and Instructional Decals	5
Setup	7
1 Preparing the Machine	9
2 Installing the ROPS Pivot Shoulder Bolts	9
3 Installing the Weights	9
4 Installing the Bagger Supports and Brackets	10
5 Installing the Bagger Frame	12
6 Installing the Bags	13
7 Installing the Hitch Cover	13
8 Removing the Existing Belt Cover, Bracket, and Discharge Chute	14
9 Installing the CE Kit	14
10 Installing the Blower-Pulley Assembly and Belt-Cover Bracket	15
11 Installing the Baffle	18
12 Installing the Blower Assembly	19
13 Installing the Blower Belt, Spring, and Blower-Belt Cover	20
14 Installing the Discharge Tubes	22
15 Adjusting the Parking Brake	24
16 Checking the Tire Pressure	24
Operation	25
Emptying the Grass Bags	25
Clearing Obstructions from the Bagger System	26
Removing the Bagger	26
Transporting the Machine	26
Operating Tips	27
Maintenance	28
Recommended Maintenance Schedule(s)	28
Cleaning the Hood Screen	28
Inspecting the Bagger Attachment	29
Cleaning the Bagger and Bags	29
Inspecting the Blower Belt	29
Replacing the Blower Belt	29
Greasing the Idler Arm	30
Inspecting the Bagger	30
Inspecting the Mower Blades	30
Selecting the Mower Blades	30
Replacing the Grass Deflector	31
Storage	31
Troubleshooting	32

Safety

- Become familiar with the safe operation of the equipment, with the operator controls, and safety signs.
- Use extra care with grass catchers or other attachments. These can change the operating characteristics and the stability of the machine.
- Follow the manufacturer's recommendations for adding or removing wheel weights or counterweights to improve stability.
- Do not use a grass catcher on steep slopes. A heavy grass catcher could cause loss of control or overturn the machine.
- Slow down and use extra care on hillsides. Be sure to travel in the recommended direction on hillsides. Turf conditions can affect the stability of the machine. Use extreme caution while operating near drop-offs.
- Keep all movement on slopes slow and gradual. Do not make sudden changes in speed, direction, or turning.
- The grass catcher can obstruct the view to the rear. Use extra care when operating in reverse.
- Use care when loading or unloading the machine into a trailer or truck.
- Never operate with the discharge deflector raised, removed or altered, unless using a grass catcher.
- Keep hands and feet away from moving parts. Do not make adjustments with the engine running.
- Park the machine on a level surface, disengage the drives, shut off the engine, leave the operator's position, and chock the wheels before performing any task such as emptying the grass catcher or unclogging the chute.
- If you remove the grass catcher, be sure to install any discharge deflector or guard that might have been removed to install the grass catcher. Do not operate the mower without either the entire grass catcher or the grass deflector in place.
- Shut off the engine before removing the grass catcher or unclogging the chute.
- Do not leave grass in the grass catcher for extended periods of time.
- Grass catcher components are subject to wear, damage and deterioration, which could expose you to moving parts or allow objects to be thrown. Frequently check components and replace with the manufacturer's recommended parts, when necessary.

Safety and Instructional Decals



Safety decals and instructions are easily visible to the operator and are located near any area of potential danger. Replace any decal that is damaged or missing.

⚠ WARNING: Cancer and Reproductive Harm - www.P65Warnings.ca.gov.
For more information, please visit www.ttcoCAProp65.com

133-8061

133-8061

decal133-8061

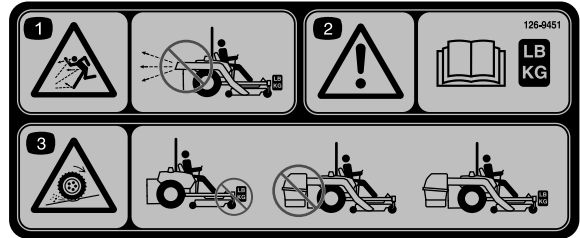

126-9451

126-9451

decal126-9451

1. Thrown objects hazard—Do not run the blower without the entire collection system installed and latched.
2. Warning—Read the *Operator's manual* about counterbalance weight installation.
3. Loss of traction and steering or reduced stability hazard—Ez Vac counterbalance weight(s) installed without the Ez Vac may cause loss of traction and steering control. The Ez Vac installed without the Ez Vac counterbalance weight(s) can cause reduced stability. Install weight(s) only when the Ez Vac is installed.

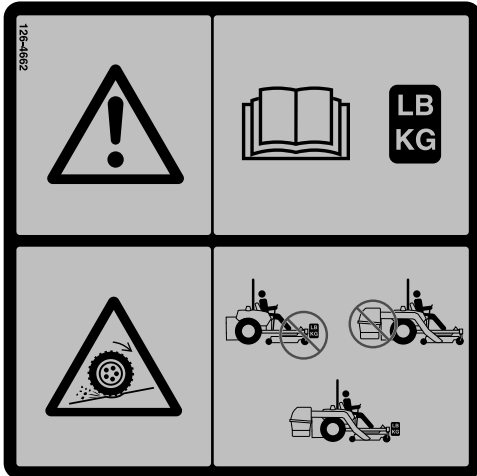

126-4662

126-4662

decal126-4662

1. Warning—read the *Operator's Manual* for the correct quantity of counterbalance weight(s).
2. Loss of traction and steering or reduced stability hazard—Ez Vac counterbalance weight(s) installed without the Ez Vac may cause loss of traction and steering control. The Ez Vac installed without the Ez Vac counterbalance weight(s) can cause reduced stability. Install weight(s) only when the Ez Vac is installed.



126-4659

126-4659

decal126-4659

1. Warning—hot pulley; allow to cool.

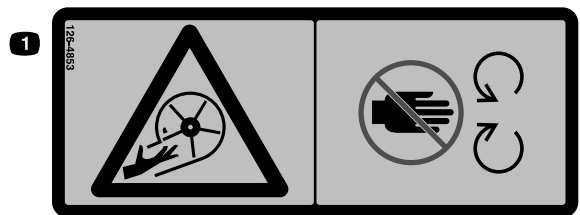

126-4853

126-4853

decal126-4853

1. Impeller/Rotating blades hazard—keep hands away from moving parts. Keep all safety devices in place and working. Do not reach into the blower unless the rotation indicator has stopped.



decal106-5517

106-5517

1. Warning—do not touch the hot surface.



decal126-9595

126-9595

1. Rotation indicator
2. Impeller/Rotating Blades hazard-Keep hands away from moving parts. Keep all safety devices in place and working. Do not reach into the blower unless the rotation indicator has stopped. Disengage the PTO, shut off the engine, remove the key, and wait for all moving parts to stop.

Setup

Loose Parts

Use the chart below to verify that all parts have been shipped.

Procedure	Description	Qty.	Use
1	No parts required	–	Prepare the machine.
2	Shoulder bolt Wave washer Locknut (1/2 inch)	2 2 2	Install the ROPS pivot shoulder bolt.
3	Weight Carriage bolt (3/8 x 1 inch) Flange nut (3/8 inch)	2 4 4	Install the weights.
4	Lower support Upper support Left, upper bracket Right, upper bracket Backer plate Carriage bolt (5/16 x 2-1/4 inches) Flange nut (5/16 inch) Plain washer Hex-head bolt (5/16 x 3-1/4 inches) Flange-head bolt (3/8 x 1-1/4 inches) Locknut (3/8 inch) Flange-head bolt (5/16 x 1 inch)	2 1 1 1 2 4 8 4 4 2 4 2	Install the bagger supports and brackets.
5	Bag support Lock-pin assembly	1 2	Install the bagger frame.
6	Bags	2	Install the bags.
7	Hitch cover	1	Install the hitch cover.
8	No parts required	–	Remove the existing belt cover, bracket, and discharge chute.
9	CE Kit	1	Install the CE Kit (for CE machines only).
10	Blower pulley Pulley mount Locknut (3/8 inch) Belt-cover bracket Speed nut Carriage bolt (1/4 x 3/4 inch) Locknut (1/4 inch)	1 1 3 1 1 2 2	Install the blower-pulley assembly.
11	Baffle Carriage bolt (5/16 x 7/8 inch) Flange nut (5/16 inch) Carriage bolt (3/8 x 7/8 inch) Flange nut (3/8 inch)	1 1 1 2 2	Install the baffle.

Procedure	Description	Qty.	Use
12	Blower assembly	1	Install the blower assembly.
	Pivot pin	1	
	Roll pin	1	
13	Blower-belt cover	1	Install the bagger belt, spring, and blower-belt cover.
	Cover knob	1	
14	Upper tube	1	Install the discharge tubes.
	Lower tube	1	
	Bolt (#10 x 3/4 inch)	3	
	Locknut (#10)	3	
	Washer (7/32 inch)	3	
15	No parts required	–	Adjust the parking brake.
16	No parts required	–	Check the tire pressure (for machine with pneumatic tires only).

Note: Determine the left and right sides of the machine from the normal operating position.

1

Preparing the Machine

No Parts Required

Procedure

1. Park the machine on a level surface.
2. Move the motion-control levers to the NEUTRAL-LOCK position.
3. Engage the parking brake.
4. Shut off the engine and remove the key.

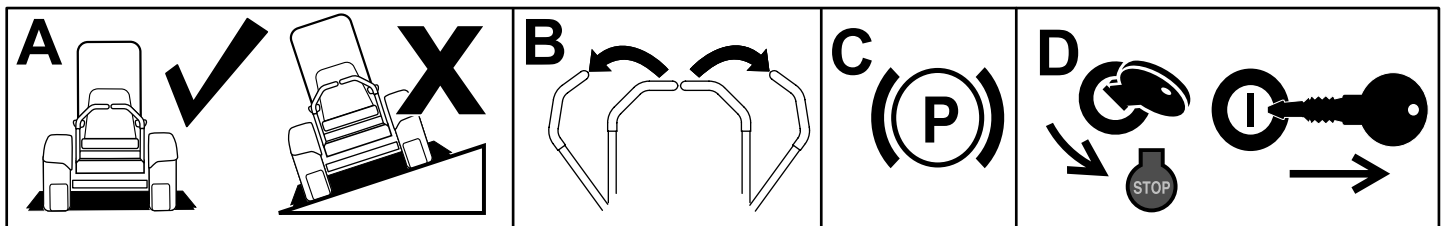

Figure 4

g037289
g037289

2

Installing the ROPS Pivot Shoulder Bolts

Parts needed for this procedure:

2	Shoulder bolt
2	Wave washer
2	Locknut (1/2 inch)

Procedure

1. Secure the shoulder bolt to the roll bar using a wave washer and locknut (1/2 inch) as shown in [Figure 5](#).
2. Repeat this procedure on the other side.

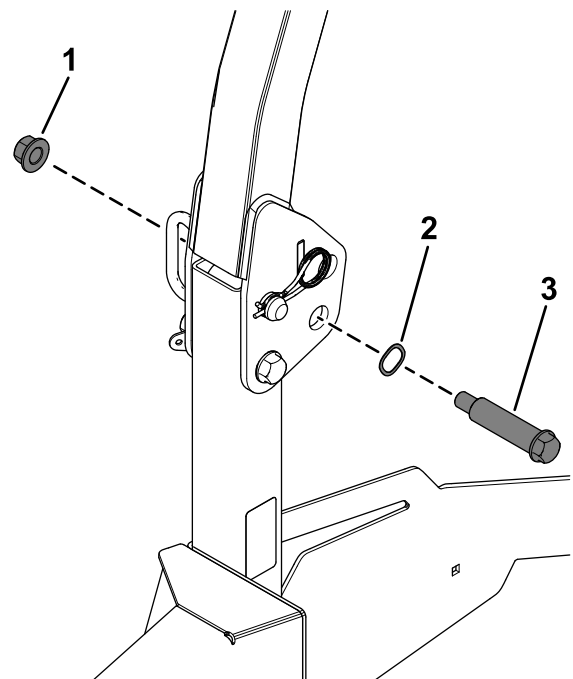

Figure 5

g341473

1. Locknut (1/2 inch)
2. Wave washer
3. Shoulder bolt

3

Installing the Weights

Parts needed for this procedure:

2	Weight
4	Carriage bolt (3/8 x 1 inch)
4	Flange nut (3/8 inch)

Procedure

1. Secure the weight to the caster arm using 2 carriage bolts (3/8 x 1 inch) and 2 flange nuts (3/8 inch) as shown in [Figure 6](#).
2. Repeat this procedure on the other side.

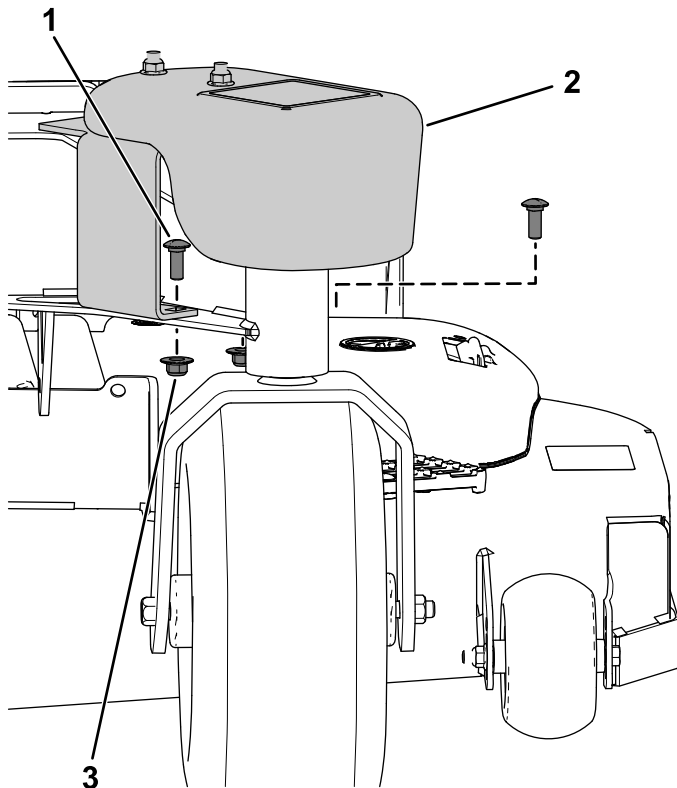

Figure 6

g341474

1. Carriage bolt (3/8 x 1 inch)
2. Weight
3. Flange nut (3/8 inch)

4

Installing the Bagger Supports and Brackets

Parts needed for this procedure:

2	Lower support
1	Upper support
1	Left, upper bracket
1	Right, upper bracket
2	Backer plate
4	Carriage bolt (5/16 x 2-1/4 inches)
8	Flange nut (5/16 inch)
4	Plain washer
4	Hex-head bolt (5/16 x 3-1/4 inches)
2	Flange-head bolt (3/8 x 1-1/4 inches)
4	Locknut (3/8 inch)
2	Flange-head bolt (5/16 x 1 inch)

Procedure

1. Loosely secure the upper support to the rear engine guard using 2 flange-head bolts (5/16 x 1 inch) and 2 flange nuts (5/16 inch) as shown in [Figure 7](#).

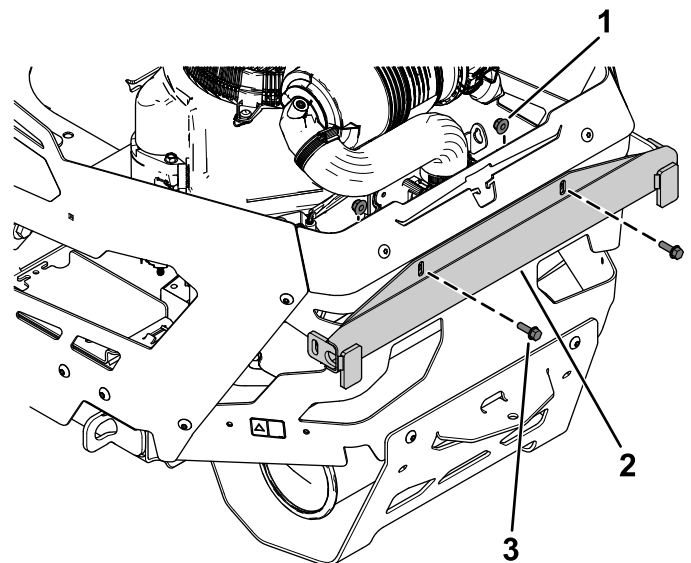

Figure 7

g341518

1. Flange nut (5/16 inch)
2. Upper support
3. Flange-head bolt (5/16 x 1 inch)

- Remove the 2 torx-head bolts and 2 nuts from the left, rear guard (Figure 8).

Note: Perform the step above on 1 side of the machine, then the other.

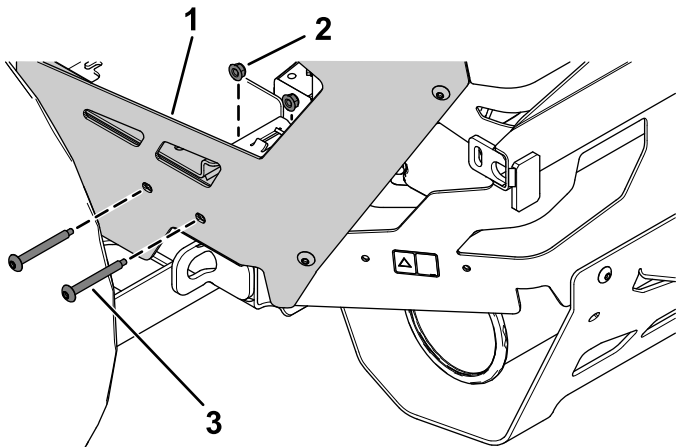

Figure 8

g341515

- Left, rear guard
- Nut
- Torx-head bolt

- Loosely secure the left, upper bracket to the left, rear guard and upper support using 2 hex-head bolts (5/16 x 3-1/4 inches), 2 plain washers, 2 flange nuts (5/16 inch), 1 flange-head bolt (3/8 x 1-1/4 inches), and 1 locknut (3/8 inch) as shown in Figure 9.

Note: Perform the step above on 1 side of the machine, then the other.

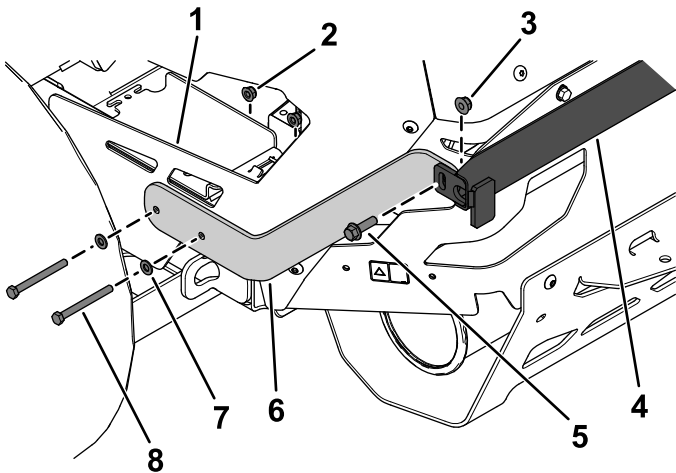

Figure 9

g341516

- Left, rear guard
- Flange nut (5/16 inch)
- Locknut (3/8 inch)
- Upper support
- Flange-head bolt (3/8 x 1-1/4 inches)
- Left, upper bracket
- Plain washer
- Hex-head bolt (5/16 x 3-1/4 inches)

- Loosely secure the lower support to the engine plate using 2 carriage bolts (5/16 x 2-1/4 inches), 1 backer plate, and 2 flange nuts (5/16 inch) as shown in Figure 10.

Note: Perform the step above on 1 side of the machine, then the other.

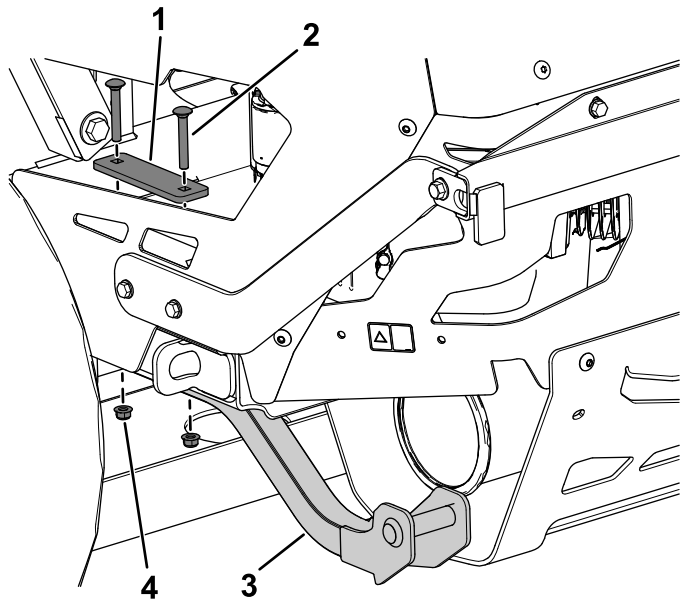

Figure 10

g341517

- Backer plate
- Carriage bolt (5/16 x 2-1/4 inches)
- Lower support
- Flange nut (5/16 inch)

- Tight all the fasteners.

5

Installing the Bagger Frame

Parts needed for this procedure:

1	Bag support
2	Lock-pin assembly

Procedure

1. Arrange the bagger frame around the pivot pins on the support bracket and rotate it forward (Figure 11).

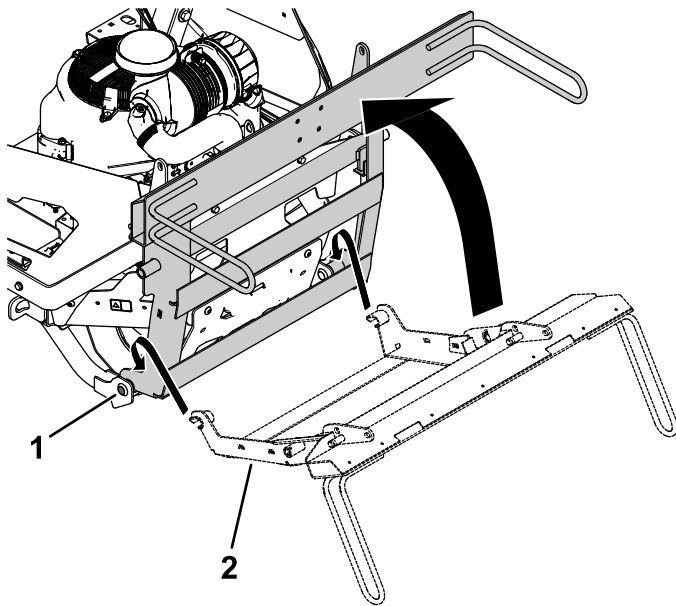

Figure 11

g341549

1. Pivot pin
2. Bagger frame

2. Insert the lock pin through the bagger frame and cross brace (Figure 12).

Note: You may need to loosen the hardware to align the lock pin to the hole.

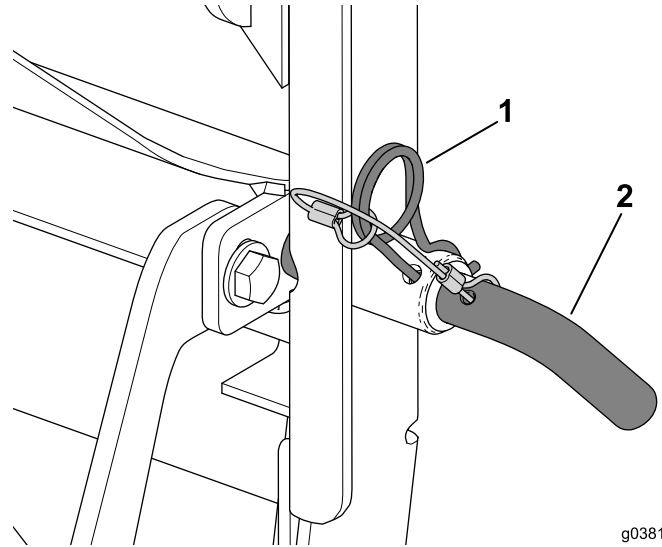

g038187
g038187

Figure 12

1. Hairpin cotter
2. Lock pin

3. Use the hairpin cotter to secure the lock pin (Figure 12).
4. Tighten all loose hardware.

6

Installing the Bags

Parts needed for this procedure:

2	Bags
---	------

Procedure

1. Hook the bag to the bagger frame (Figure 13).

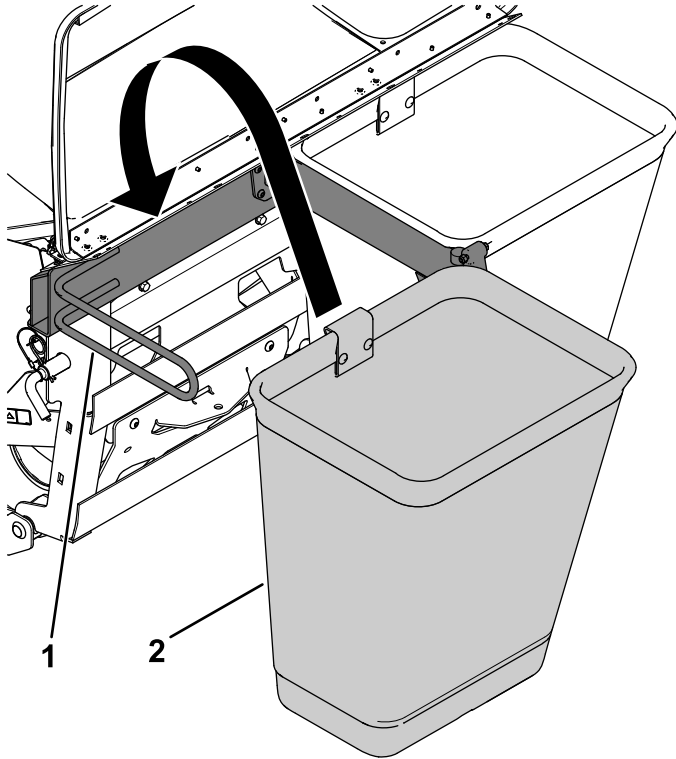

Figure 13

g341571

1. Bagger frame
2. Bag

7

Installing the Hitch Cover

Parts needed for this procedure:

1	Hitch cover
---	-------------

Procedure

1. Apply a lubricant to the nipple on the hitch cover.
2. Align the hitch cover over the hitch and press it into place (Figure 14).

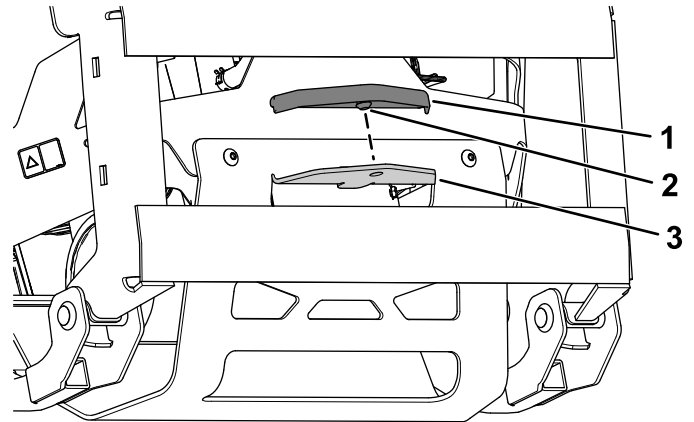

g341572

Figure 14

1. Hitch cover
2. Nipple
3. Hitch

2. Close and latch the hood assembly.

8

Removing the Existing Belt Cover, Bracket, and Discharge Chute

No Parts Required

Procedure

Note: Clean the area around the belt cover before removing it.

1. Lower the mower deck to the lowest height-of-cut position.
2. Remove the right belt cover (Figure 15).

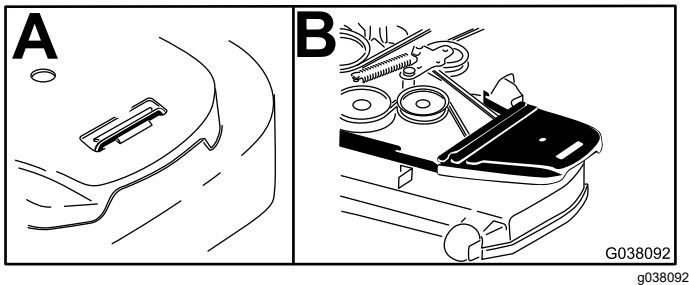

Figure 15

3. Remove the right belt-cover bracket, 2 washers (60-inch mower deck only), and 2 flange nuts from the mower deck (Figure 16).

Note: Retain the hardware that you removed during this procedure so that it is available for changeover.

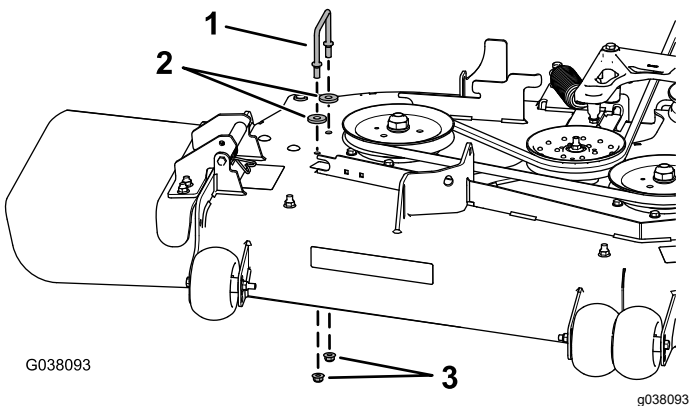

Figure 16

1. Right belt-cover bracket
2. Washers-only on 152 cm (60 inch) mower deck
3. Flange nuts

4. Remove the locknut, bolt, spring, and spacer holding the deflector to the pivot brackets (Figure 17).

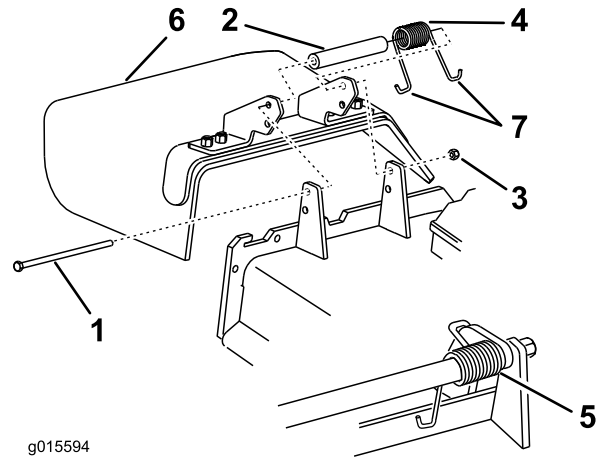

Figure 17

1. Bolt
2. Spacer
3. Locknut
4. Spring
5. Spring installed
6. Grass deflector
7. J-hook end of spring

5. Remove the grass deflector (Figure 17).

Note: Retain the hardware that you removed during this procedure so that it is available for changeover.

9

Installing the CE Kit

For CE Machines Only

Parts needed for this procedure:

1	CE Kit
---	--------

Procedure

For CE machines, you need to install the CE Kit; refer to the *Declaration of Conformity* for the CE Kit model number.

10

Installing the Blower-Pulley Assembly and Belt-Cover Bracket

Parts needed for this procedure:

1	Blower pulley
1	Pulley mount
3	Locknut (3/8 inch)
1	Belt-cover bracket
1	Speed nut
2	Carriage bolt (1/4 x 3/4 inch)
2	Locknut (1/4 inch)

Procedure

1. Use a 3/8-inch ratchet in the square hole in the idler arm to remove tension on the idler spring (Figure 18).

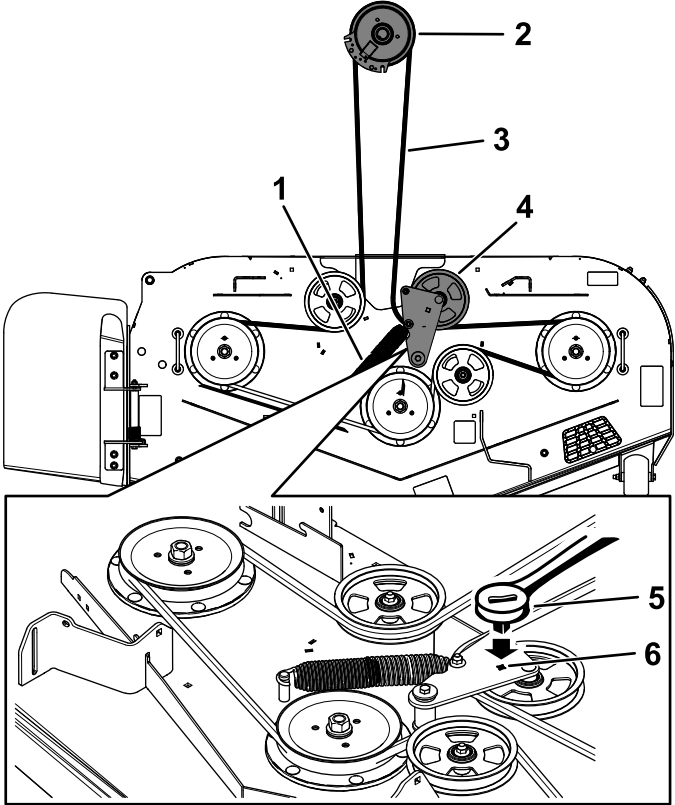

g334846

Figure 18

1. Spring
 2. Clutch pulley
 3. Mower belt
 4. Spring-loaded idler assembly
 5. Ratchet
 6. Square hole in the idler arm for the ratchet
-
2. Remove the belt from the right mower-deck pulley.

- Use a wrench (1-1/2 inches) to hold the spindle shaft, as you remove the hex nut (3/4 inch) and washer from the spindle shaft (Figure 19).

Note: Retain the hex nut (3/4 inch) and washer.

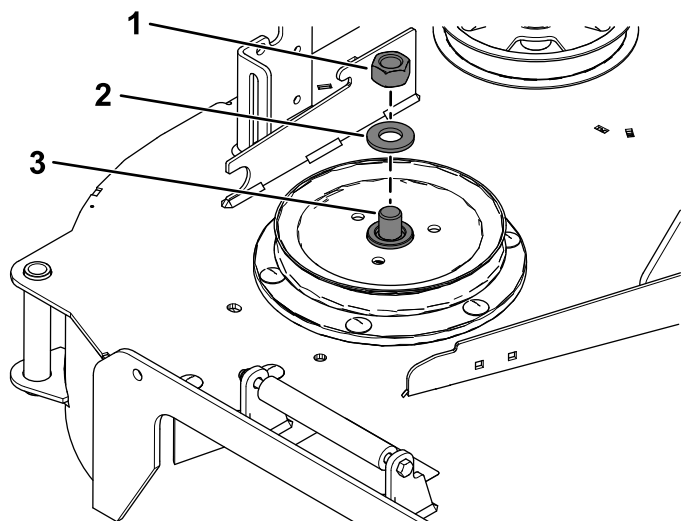

Figure 19

- | | |
|-----------------------|------------------------|
| 1. Hex nut (3/4 inch) | 3. Right spindle shaft |
| 2. Washer | |

- Insert the threaded studs on pulley mount through the holes in the deck pulley (Figure 20).
- Secure the deck pulley to the spindle shaft using the previously removed hex nut (3/4 inch) and washer (Figure 20).
- Torque the hex nut (3/4 inch) to 176 to 217 N·m (130 to 160 ft-lb).
- Arrange the blower pulley onto the threaded studs and loosely install the 3 locknuts (3/8 inch) as shown in Figure 20.
- Rotate the blower pulley until the narrow slots stop on the studs.
- Torque the 3 locknuts (3/8 inch) to 18 N·m (13 ft-lb).

Ensure that the pulley does not rotate while torquing the locknuts.

Note: If the blower pulley is not centered on the studs, it could cause premature damage to the blower belt.

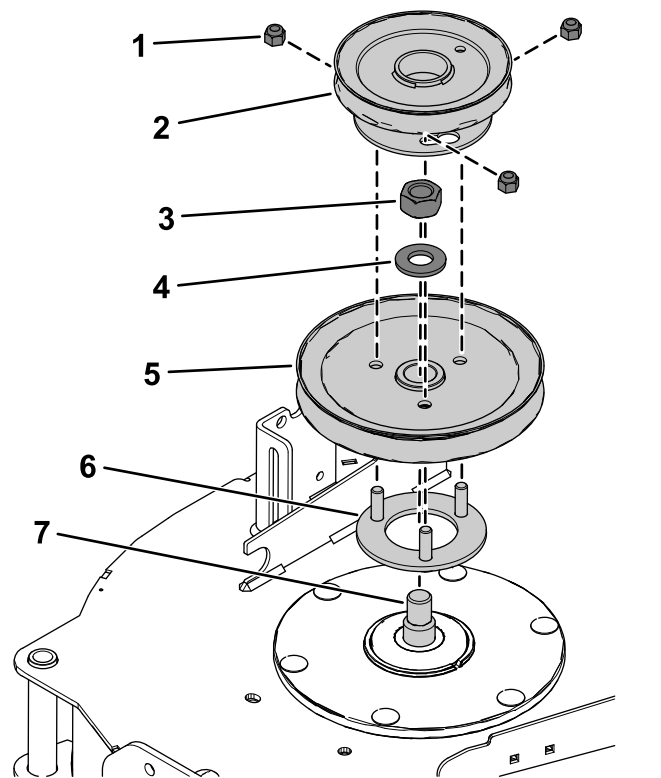
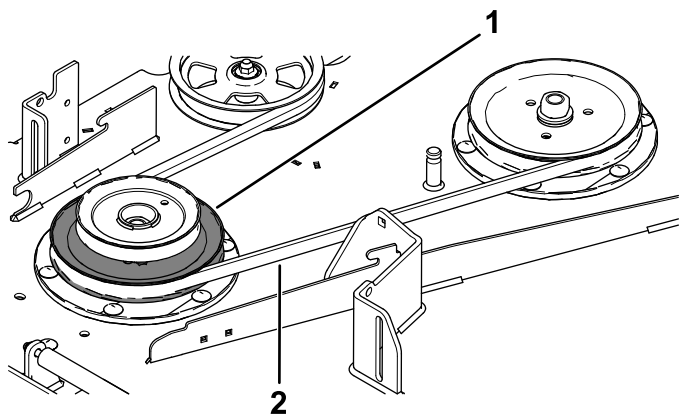

Figure 20

- | | |
|-----------------------|-------------------------|
| 1. Locknut (3/8 inch) | 5. Existing deck pulley |
| 2. Blower pulley | 6. Pulley mount |
| 3. Hex nut (3/4 inch) | 7. Right spindle shaft |
| 4. Washer | |

10. Ensure that the blade bolt is torqued to 75 to 81 N·m (55 to 60 ft-lb).
11. Install the mower belt around the lower pulley of the double pulley ([Figure 21](#)).



g341575

Figure 21

- | | |
|-----------------|---------------|
| 1. Lower pulley | 2. Mower belt |
|-----------------|---------------|

12. Install the belt-cover bracket to the mower deck using 2 carriage bolts (1/4 x 3/4 inch) and 2 locknuts (1/4 inch) as shown in [Figure 22](#).
13. Install the speed nut onto the belt-cover bracket ([Figure 22](#)).

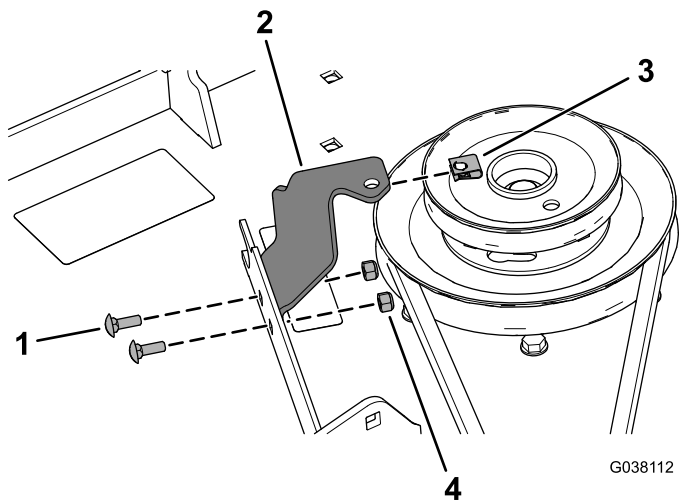

G038112

g038112

Figure 22

- | | |
|-----------------------------------|-----------------------|
| 1. Carriage bolt (1/4 x 3/4 inch) | 3. Speed nut |
| 2. Belt-cover bracket | 4. Locknut (1/4 inch) |

14. Install the mower deck belt around the spring-loaded idler pulley ([Figure 18](#)).

11

Installing the Baffle

Parts needed for this procedure:

1	Baffle
1	Carriage bolt (5/16 x 7/8 inch)
1	Flange nut (5/16 inch)
2	Carriage bolt (3/8 x 7/8 inch)
2	Flange nut (3/8 inch)

Procedure

1. Remove the 2 existing flange nuts (3/8 inch) and 2 carriage bolts (3/8 x 7/8 inch) from the mower deck (Figure 23).

Note: Retain the hardware that you removed during this procedure so that it is available for changeover.

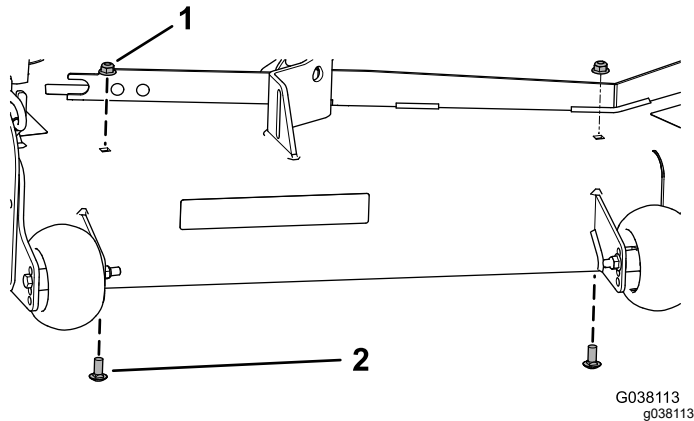

Figure 23

1. Flange nut (3/8 inch)
2. Carriage bolt (3/8 x 7/8 inch)

2. Install the baffle using the carriage bolt (5/16 x 7/8 inch), flange nut (5/16 inch), 2 carriage bolts (3/8 x 7/8 inch), and 2 flange nuts (3/8 inch) as shown in Figure 24.

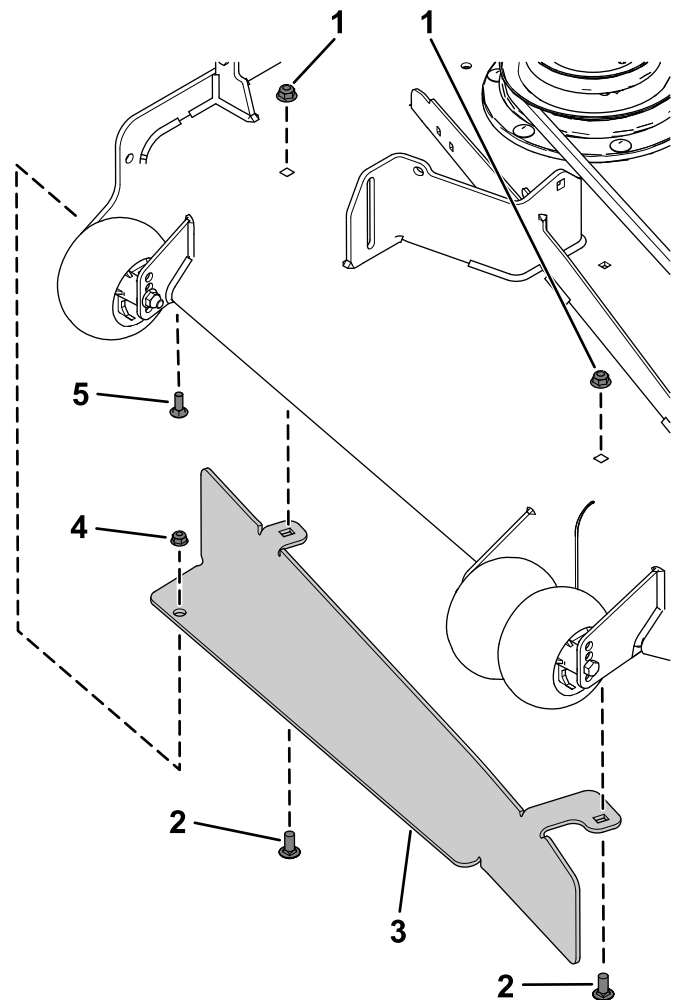

Figure 24

1. Flange nut (3/8 inch)
2. Carriage bolt (3/8 x 7/8 inch)
3. Baffle
4. Flange nut (5/16 inch)
5. Carriage bolt (5/16 x 7/8 inch)

12

Installing the Blower Assembly

Parts needed for this procedure:

1	Blower assembly
1	Pivot pin
1	Roll pin

Procedure

Verify that the pivot pin is secured on the blower assembly in the correct location (Figure 25 or Figure 26).

- If you have a **48-inch or 52-inch** mower deck, there is only a single hole to install the pivot pin (Figure 25).

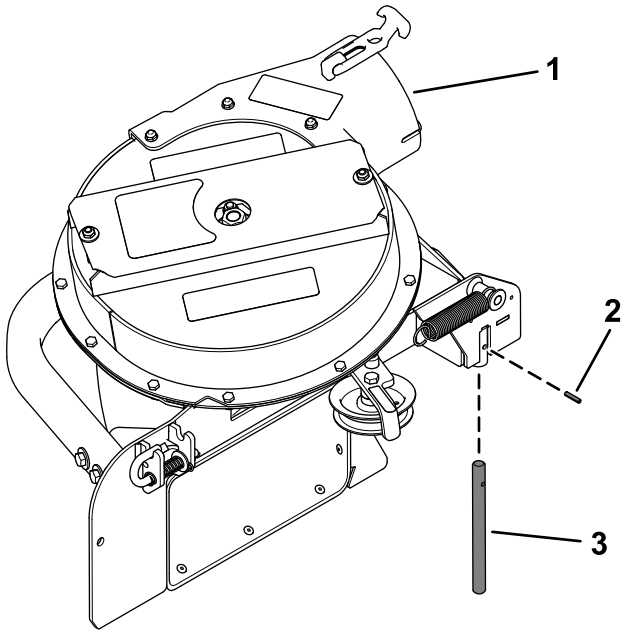

Figure 25

g341588

- 1. Blower assembly
- 2. Roll pin
- 3. Pivot pin

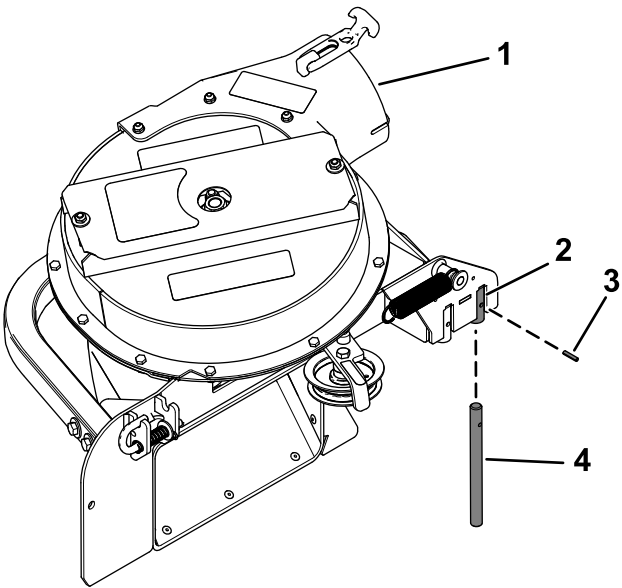

Figure 26

g341589

- 1. Blower assembly
- 2. Rear hole
- 3. Roll pin
- 4. Pivot pin

- Align the pivot pin on the blower with the pivot-pin hole in the mower deck (Figure 27).

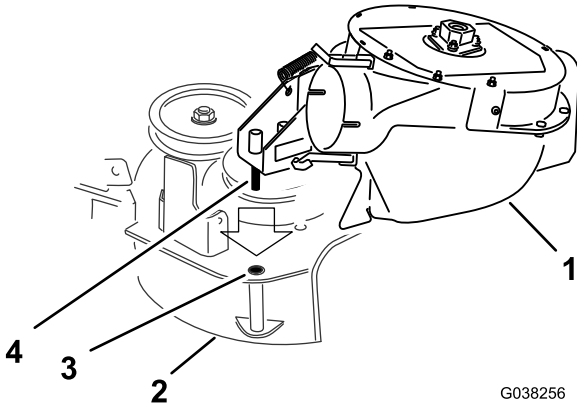

Figure 27

G038256

g038256

- 1. Blower assembly
- 2. Deck
- 3. Pivot hole
- 4. Blower-pivot pin

- Lower the blower and slide the pivot pin into the pivot hole (Figure 27).

Note: Ensure that the belt remains positioned in the blower pulley.

- If you have a **60-inch** mower deck, install the pivot pin in the rear hole (Figure 26).

3. Move the latch pin from the locking position to the open position (Figure 28).

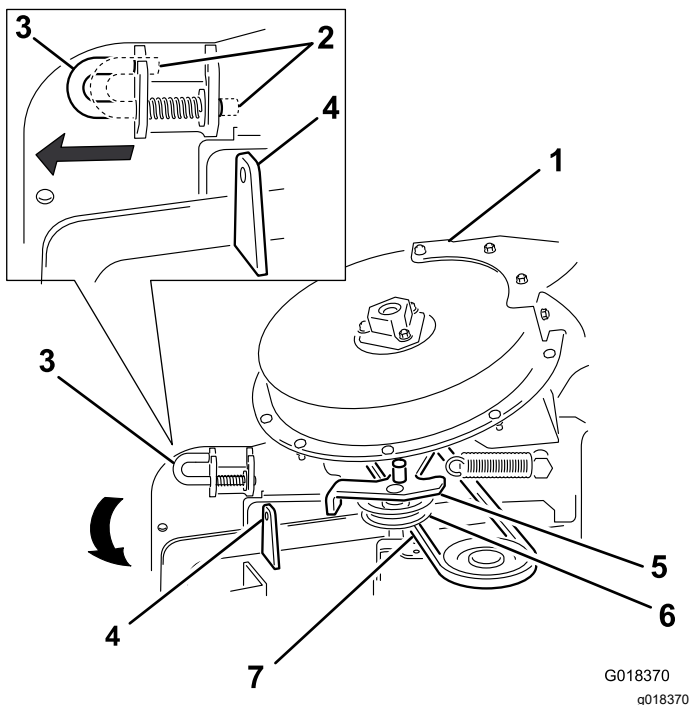

Figure 28

G018370
g018370

- | | |
|---------------------------------|------------------------------------|
| 1. Blower assembly | 5. Idler-pivot bracket |
| 2. Latch pin (locking position) | 6. Idler pulley |
| 3. Latch pin (open position) | 7. Belt (beneath the idler pulley) |
| 4. Chute bracket | |

4. Close the blower assembly and align the latch pin with the hole in the chute bracket (Figure 28).
5. Move the latch pin to the locking position.

Note: Ensure that the latch pin extends through the hole in the chute bracket.

Note: Ensure that the latch firmly holds the blower assembly against the mower deck, but you can release it by hand.

13

Installing the Blower Belt, Spring, and Blower-Belt Cover

Parts needed for this procedure:

1	Blower-belt cover
1	Cover knob

Procedure

1. Arrange the blower belt around the drive pulley as shown in Figure 29.

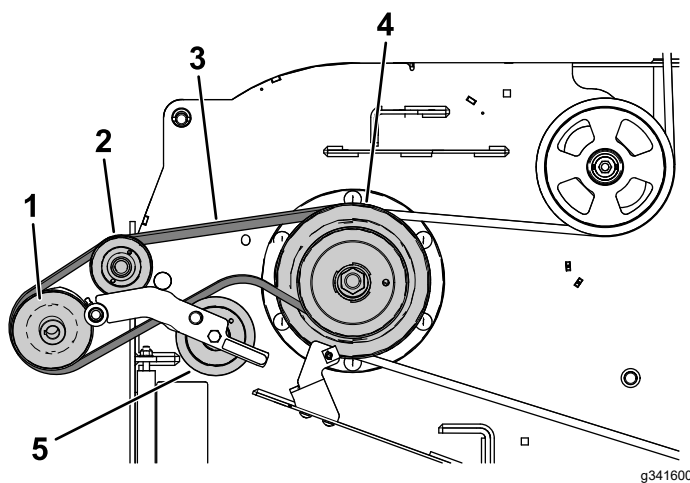

Figure 29

g341600

- | | |
|------------------|-------------------------|
| 1. Blower pulley | 4. Drive pulley |
| 2. Idler/pulley | 5. Idler/tension pulley |
| 3. Blower belt | |

2. Temporarily route the belt beneath the idler pulley (Figure 30).

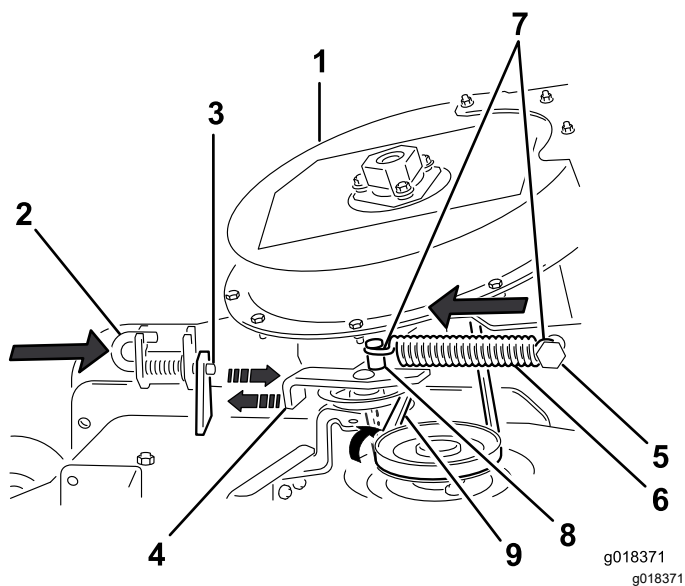

Figure 30

Installing the tension spring and aligning the belt

- | | |
|---------------------------------|---------------------------------------|
| 1. Blower assembly | 6. Spring |
| 2. Latch pin (locking position) | 7. Idler-spring post |
| 3. Chute bracket | 8. Spring (hook end) |
| 4. Idler-pivot bracket | 9. Belt (aligned to the idler pulley) |
| 5. Fixed spring post | |

3. Move the idler-pivot bracket toward the fixed spring post and install the spring by aligning the spring hook onto the idler-spring post (Figure 30).

Note: Ensure that the spring hooks are positioned correctly on the spring posts.

4. Pull the spring-loaded idler pulley away from the fixed spring post, and route the belt around the deck pulley (Figure 30).

Note: Ensure that the belt is correctly routed around the blower pulley.

5. Install the blower-belt cover over the blower belt and secure the blower-belt cover with the belt knob (Figure 31).

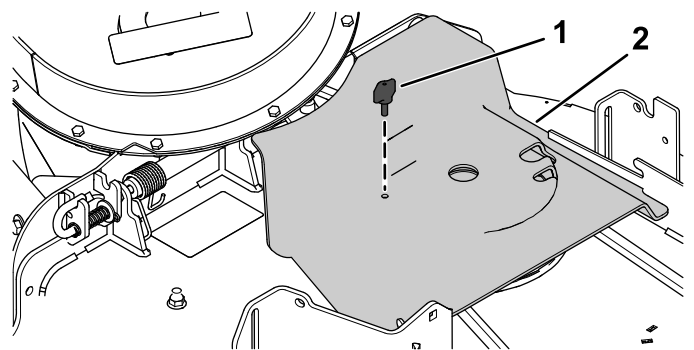

Figure 31

- | | |
|---------------|----------------------|
| 1. Cover knob | 2. Blower-belt cover |
|---------------|----------------------|

14

Installing the Discharge Tubes

Parts needed for this procedure:

1	Upper tube
1	Lower tube
3	Bolt (#10 x 3/4 inch)
3	Locknut (#10)
3	Washer (7/32 inch)

Procedure

1. Lower the machine deck to the lowest height-of-cut position.
2. Remove the bags for viewing the tube under the hood.
3. Install the upper tube into the bagger opening and pull it back out so that the hopper seal is protruding out (Figure 32).

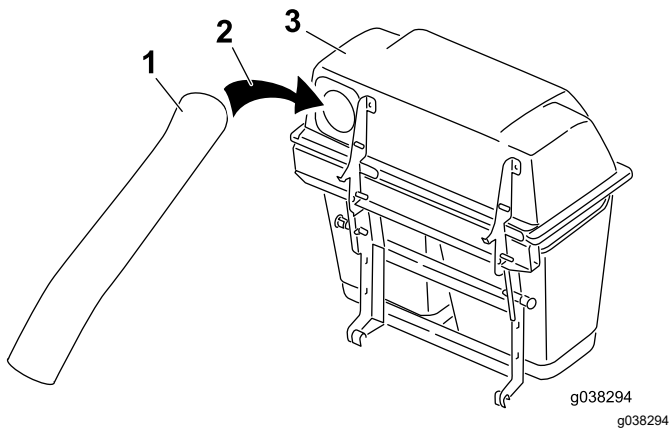

Figure 32

1. Upper tube
2. Bagger opening
3. Bagger hood

4. Align the dimple in the upper tube equally between the screws securing the hopper seal to the hopper (Figure 33).

Note: The hopper seal must protrude outward from the bagger hood.

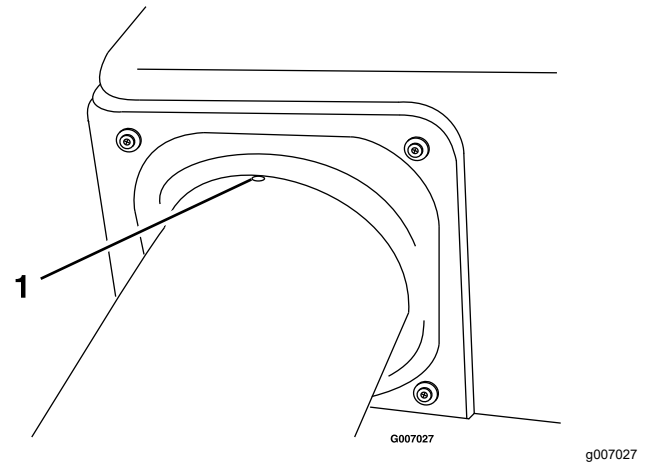

Figure 33

1. Dimple

5. Install the lower tube into the upper tube (Figure 34).

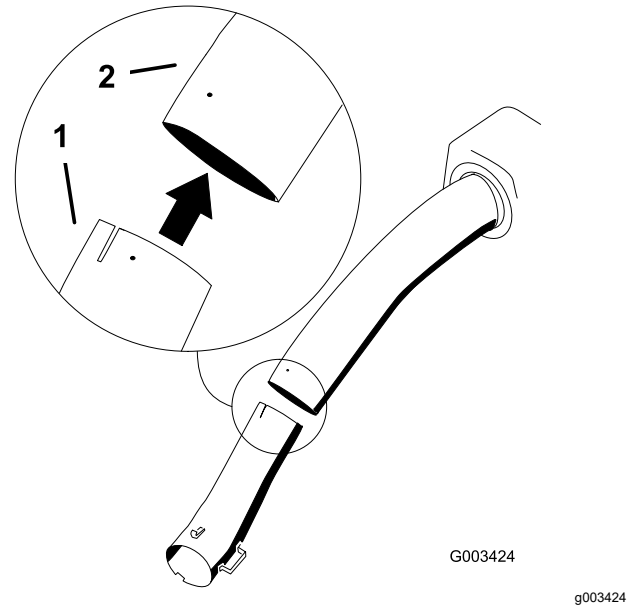

Figure 34

1. Lower tube
2. Upper tube

6. Slide the lower tube onto the blower housing and latch them together (Figure 35).

Note: There is a latch on the top and bottom of the blower housing.

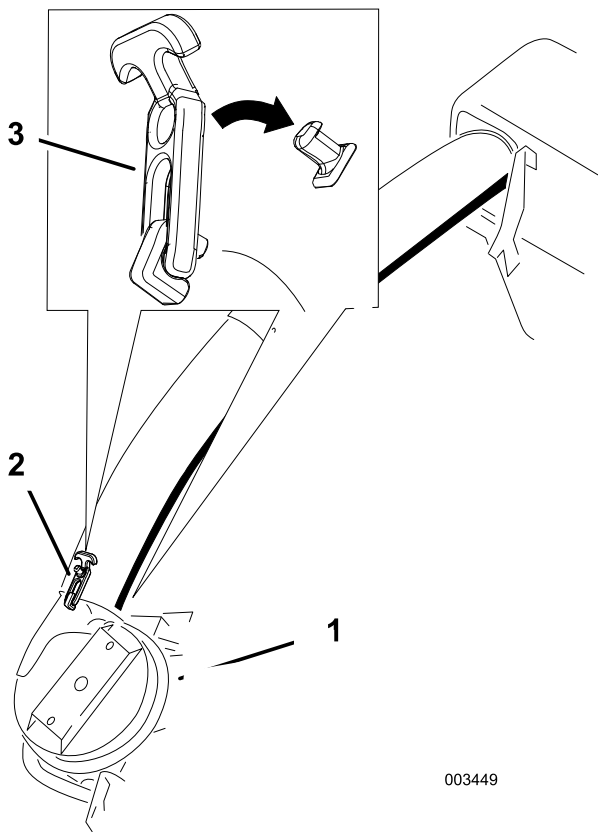

Figure 35

- 1. Blower assembly
- 2. Lower tube
- 3. Latch (twin bagger shown)

003449

g003449

diameter) where the upper and lower tubes join together (Figure 36).

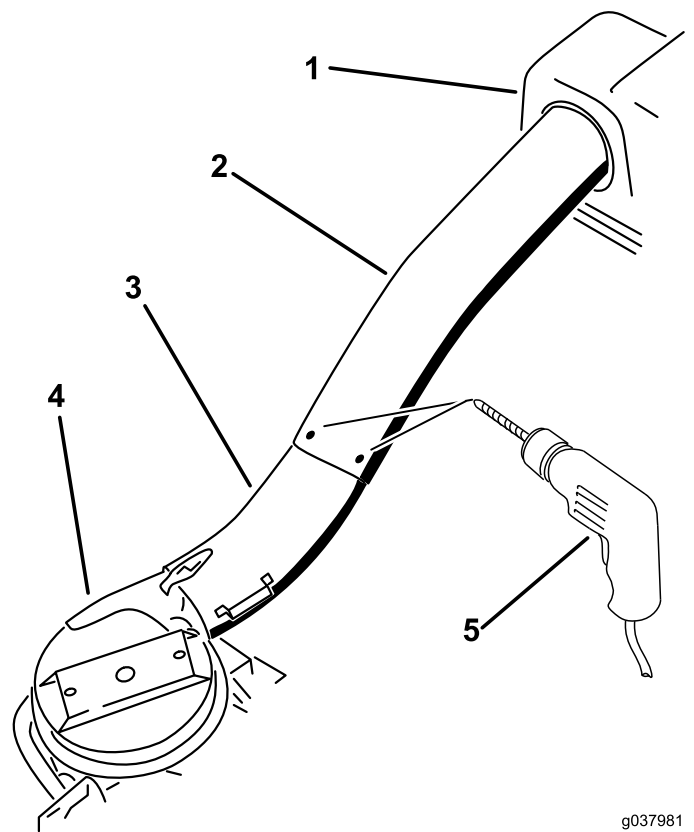

Figure 36

- 1. Bagger hood
- 2. Upper tube
- 3. Lower tube
- 4. Blower assembly
- 5. Drill holes (7/32 inch)

g037981
g037981

- 7. Ensure that the machine deck is in the lowest height-of-cut position.
- 8. Verify that the dimple from Figure 33 is still in place.
- 9. Using the 3 holes or indentations in the upper tube as a template, and drill 3 holes (7/32 inch

- 10. Remove the lower tube from the blower housing.

- Join the upper and lower tubes with 3 bolts (#10 x 3/4 inch), flat washers, and locknuts as shown in [Figure 37](#).

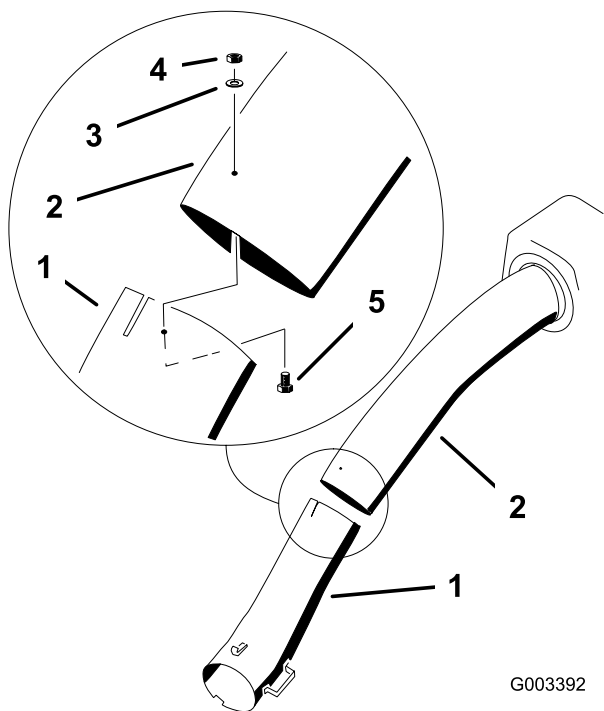

Figure 37

G003392

g003392

- | | |
|----------------------------|--------------------------|
| 1. Lower tube | 4. Locknut (#10) |
| 2. Upper tube | 5. Bolt (#10 x 3/4 inch) |
| 3. Flat washer (7/32 inch) | |

- Install the lower tube onto the blower housing and secure it with the latches.

15

Adjusting the Parking Brake

No Parts Required

Procedure

Check to ensure that the parking brake is adjusted properly. Refer to your *Operator's Manual* for the correct procedure.

16

Checking the Tire Pressure

For Machines with Pneumatic Tires Only

No Parts Required

Procedure

Increase the tire pressure due to the additional weight.

Note: This is not applicable with semi-pneumatic tires.

Maintain the air pressure in the rear tires at 90 kPa (13 psi). Uneven tire pressure can cause uneven cut. Check the tires when they are cold to get the most accurate pressure reading.

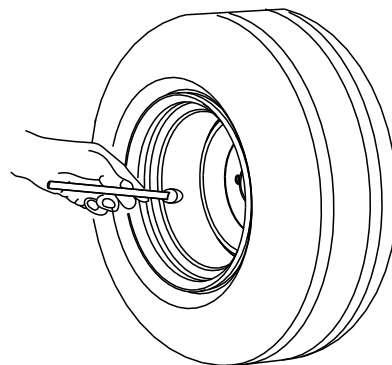

G001055

Figure 38

g001055

Operation

Note: Determine the left and right sides of the machine from the normal operating position.

⚠ WARNING

To avoid personal injury, follow these procedures:

- Become familiar with all operating and safety instructions in the *Operator's Manual* for the mower before using this attachment.
- Never remove the discharge tube, bags, bagger top, or the chute while the engine is running.
- Always shut the engine off and wait for all moving parts to stop before clearing an obstruction from the bagging system.
- Never do maintenance or repairs while the engine is running.

⚠ WARNING

Without the grass deflector, bagger tubes or complete bagger assembly mounted in place, you and others are exposed to blade contact and thrown debris. Contact with the rotating mower blade(s) and thrown debris will cause injury or death.

- Always install the grass deflector when removing the bagger and changing to side discharge mode.
- If the grass deflector is ever damaged, replace it immediately. The grass deflector routes material down toward the turf.
- Never put your hands or feet under the mower.
- Never try to clear the discharge area or mower blades unless you move the power take off (PTO) to off and rotate the ignition key to off. Also remove the key and pull the wire off of the spark plug(s).
- Turn off the engine before unclogging the discharge chute.

Emptying the Grass Bags

⚠ WARNING

Debris, such as leaves, grass, or brush can catch fire. A fire in the engine area can cause personal injury and property damage.

- Keep the engine and muffler area free of debris accumulation.
- Take care when opening the bagger cover to keep debris from falling onto the engine and muffler area.
- Allow the machine to cool before storing it.

Grass bags are heavy when full. Be careful when lifting or handling a grass bag that is full.

1. Park the machine on a level surface and disengage the blade control switch.
2. Move the motion control levers outward to the neutral lock position, shut off the engine, remove the key, set the parking brake and wait for all moving parts to stop before leaving the operating position.
3. Unlatch the bagger latch.
4. Open the bagger hood.
5. Compress the debris into the bags. With both hands, lift up on the bag and unhook it from the bagger bracket.
6. Grab the handle on the bottom of the bag and tip it over to empty the bag ([Figure 39](#)).

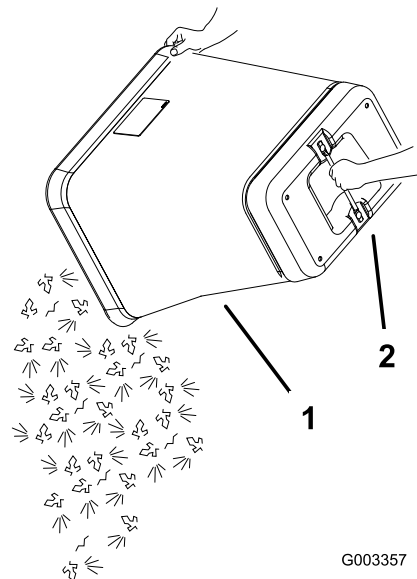

Figure 39

1. Bag
2. Bottom handle

7. Install the bag tab into the notch in the bagger support frame.

8. Lower the bagger hood over the bags.
9. Latch the bagger hood.

Clearing Obstructions from the Bagger System

⚠ WARNING

When the bagger is in operation, the blower is rotating and can cut off or injure hands and fingers.

- **Before adjusting, cleaning, repairing, and inspecting the blower, and before unclogging the chute, shut off the engine, wait for all moving parts to stop, and remove the key.**
 - **Ensure that the rotation indicator stops.**
 - **Use a stick, not your hands, to remove an obstruction from the blower and tube.**
 - **Keep your hands and feet away from moving parts. Do not make adjustments with the engine running.**
1. Disengage the PTO and engage the parking brake.
 2. Shut off the engine, remove the key, and wait for all moving parts to stop before leaving the operating position.
 3. Empty the bags.
 4. Unlatch the lower tube.
 5. Remove the tubes from the bagger.
 6. Use a stick or similar object to remove and clear the obstruction from the tube assembly.
Note: In most cases, the debris can be shaken out of the tubes.
 7. If the blower assembly is plugged, unlatch the bagger blower assembly, remove the belt, and swing it open.
 8. Use a stick or similar object, not your hands, to remove and clear the obstruction from the blower assembly.
 9. Completely install the bagger system before you resume mowing.

Removing the Bagger

⚠ WARNING

Components around the engine are hot if the machine has been running. Touching hot components can cause burns.

- **Do not touch the engine hot components.**
 - **Allow engine to cool before removing the bagger.**
1. Disengage the PTO.
 2. Shut off the engine, engage the parking brake, remove the key, and wait for all moving parts to stop before leaving the operating position.
 3. Unlatch the lower tube from the blower and remove the tube from the blower assembly.
 4. Remove the tube from the bagger hood.
 5. Lower the mower deck to the lowest height-of-cut position.
 6. Remove the knob that secures the belt cover to the mower deck.
 7. Remove the blower belt from the mower-pulley assembly.
 8. Open the blower assembly.
 9. Remove the blower assembly from the pivot hole.
 10. If you are changing to side discharge mode, ensure that the grass deflector is installed and can be lowered into working position.
 11. Remove the hood and bag assembly.

Transporting the Machine

Do not leave grass or debris in the bagger while transporting the machine.

⚠ DANGER

Transporting the machine with grass or debris in the bagger can damage the machine.

Do not leave grass or debris in the bagger while transporting the machine.

Operating Tips

Tips for Bagging

Remembering the Size

Remember that the machine is longer and wider with this attachment installed. By turning too sharply in confined places you may damage the attachment.

Trimming

Always trim with the left side of the mower. Do not trim with the right side of the mower because you could damage the bagger chute and discharge tube.

Cutting Height

Do not set the mower cutting height too low because long grass surrounding the mower can prevent air from getting under the mower and entering the bagging system. If not enough air gets under the mower, the bagging system will plug.

Cutting Frequency

Cut the grass often, especially when it grows rapidly. You will have to cut your grass twice if it gets excessively long.

Cutting Technique

For best lawn appearance, be sure to slightly overlap the mower into the previously cut area. This helps reduce the load on the engine and reduces the chance of plugging the chute and discharge tube.

Bagging Speed

Most often, you will bag with the mower throttle in the FAST position and drive at a normal ground speed. However, in extremely dry and dusty grass, you may want to slightly reduce the throttle speed and increase the ground speed of the mower. The bagging system may plug if you drive too fast and the engine speed gets too slow. On hills, it may be necessary to slow the mower ground speed. This helps maintain the engine speed and bagging efficiency. Mow downhill whenever possible.

⚠ CAUTION

As the bagger fills, extra weight is added to the back of the machine. If you stop and start the machine suddenly on hills, you may lose steering control or the machine may tip.

- **Do not start or stop suddenly when going uphill or downhill. Avoid uphill starts.**
- **If you do stop the machine when going uphill, disengage the blade control. Then back down the hill using a slow speed.**
- **Avoid sudden turns or rapid speed changes on slopes.**
- **Never operate the machine without the bagger attachment and the front weights still installed.**

Bagging Long Grass

Excessively long grass is heavy and may not be propelled completely into the grass bags. If this happens, the discharge tube and chute may plug. To avoid plugging the bagging system, mow the grass at a high height of cut, then lower the mower to your normal cutting height and repeat the bagging process.

Bagging Wet Grass

Always try to cut grass when it is dry because your lawn will have a neat appearance. If you must cut wet grass, use the conventional side discharge feature of the mower. Several hours later, when the clippings are dry, install the complete bagger attachment and vacuum up the grass clippings.

Signs of Plugging

As you are bagging, a small amount of grass clippings normally blow out the front of the mower. An excessive amount of clippings blowing out indicates that the bags are full or the system is plugged.

Maintenance

Note: Determine the left and right sides of the machine from the normal operating position.

Recommended Maintenance Schedule(s)

Maintenance Service Interval	Maintenance Procedure
After the first 8 hours	<ul style="list-style-type: none">• Inspect the blower belt.• Inspect the bagger.
After the first 10 hours	<ul style="list-style-type: none">• Inspect the bagger.
Before each use or daily	<ul style="list-style-type: none">• Clean the hood screen.• Clean the bagger.
Every 25 hours	<ul style="list-style-type: none">• Inspect the blower belt.
Every 50 hours	<ul style="list-style-type: none">• Grease the idler arm.
Every 100 hours	<ul style="list-style-type: none">• Inspect the bagger.
Before storage	<ul style="list-style-type: none">• Inspect the bagger.

⚠ WARNING

If you leave the key in the ignition switch, someone could accidentally start the engine and seriously injure you or other bystanders.

Remove the key from the ignition and disconnect the wire from the spark plug before you do any maintenance. Set the wire aside so that it does not accidentally contact the spark plug.

⚠ WARNING

Engines can become hot when they are operating. Burns can occur from contacting hot surfaces.

Allow engines, especially the muffler, to cool before touching.

⚠ WARNING

Debris, such as leaves, grass, or brush can catch fire. A fire in the engine area can cause personal injury and property damage.

- Keep the engine and muffler area free of debris accumulation.
- Take care when opening the bagger cover to keep debris from falling onto the engine and muffler area.
- Allow the machine to cool before storing it.

Cleaning the Hood Screen

Service Interval: Before each use or daily

The screens need to be cleaned before each use.

1. Park the machine on a level surface.
2. Disengage the blade-control switch, engage the parking brake, and move the motion-control levers outward to the NEUTRAL-LOCK position.
3. Shut off the engine and remove the key.
4. Open the bagger hood.
5. Clean the debris from the screen.
6. Close the bagger hood.

Inspecting the Bagger Attachment

Service Interval: After the first 10 hours

Before storage

Inspect the bagger attachment after the first 10 hours of operation, and monthly thereafter.

1. Check the chute, discharge tube, and the bagger top. Replace these parts if they are cracked or broken.
2. Tighten all nuts, bolts, and screws.
3. Inspect all fasteners and latches; replace any missing or damaged.
4. Inspect the grass bags for deterioration.

⚠ WARNING

You or bystanders could be severely injured by flying debris or thrown objects that may pass through torn, worn, or deteriorated grass bags.

- Check the grass bags for holes, rips, wear, and other deterioration.
- If the bag has deteriorated, install new grass bags supplied by the manufacturer of this bagger attachment.

Cleaning the Bagger and Bags

Service Interval: Before each use or daily

The bagger needs to be cleaned daily.

1. Wash the inside and outside of the bagger hood, bags, tube, and the underside of the mower deck. Use a mild automotive detergent to remove dirt.
2. Ensure that you remove matted grass from all parts.
3. After washing all the parts, let them dry thoroughly.

Note: With all parts installed, start and run the machine for approximately 1 minute to assist in drying.

Inspecting the Blower Belt

Service Interval: After the first 8 hours

Every 25 hours

Check belts for cracks, frayed edges, burn marks, or any other damage. Replace any belts that are damaged.

Replacing the Blower Belt

1. Disengage the PTO, move the motion-control levers to the NEUTRAL-LOCK position, and engage the parking brake.
2. Shut off the engine, remove the key, and wait for all moving parts to stop before leaving the operating position.
3. Loosen or remove belt guide (Figure 40).
4. Pull back on the spring-loaded idler pulley to relieve the belt tension (Figure 40).

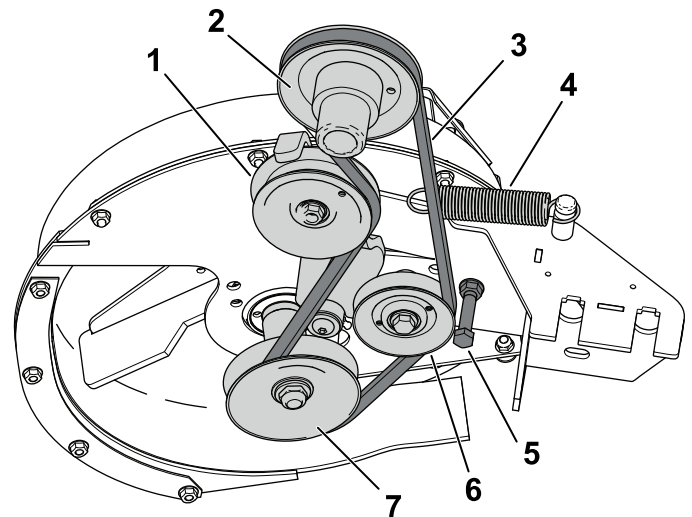

Figure 40

g189890

- | | |
|-------------------------------|------------------|
| 1. Spring-loaded idler pulley | 5. Belt guide |
| 2. Mower-deck pulley | 6. Idler pulley |
| 3. Belt | 7. Blower pulley |
| 4. Spring | |

5. Remove the existing blower belt.
6. Install the new belt around the blower pulley (Figure 40).
7. Tighten or install the belt guide (Figure 40).
8. Install the spring as shown in Figure 41.

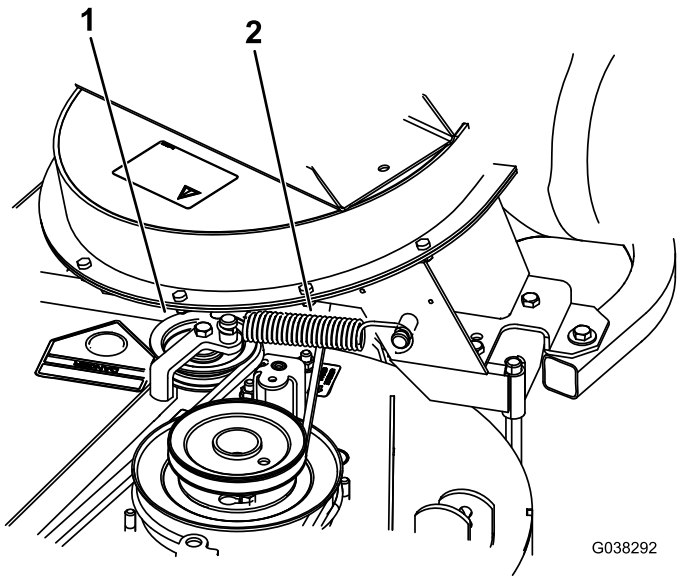

Figure 41

1. Spring-loaded idler pulley 2. Spring

9. Install the belt onto the spring-loaded idler pulley (Figure 41).

Greasing the Idler Arm

Service Interval: Every 50 hours

Grease the bagger belt idler arm (Figure 42) every 50 hours.

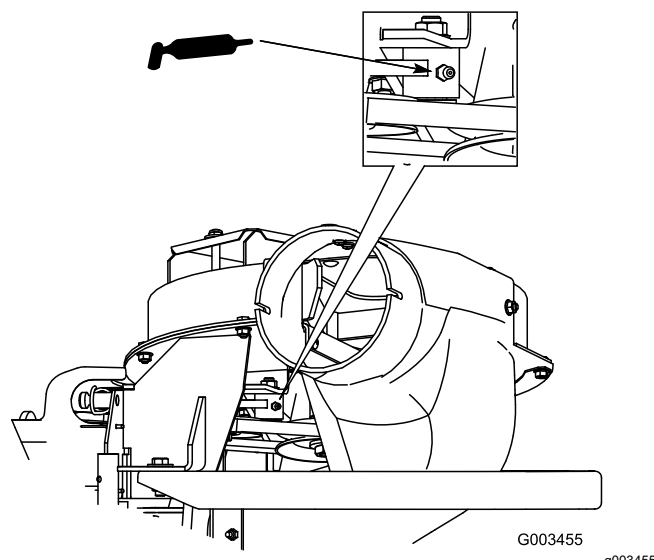

Figure 42

Inspecting the Bagger

Service Interval: Every 100 hours

After the first 8 hours

1. Disengage the PTO, move the motion-control levers to the NEUTRAL-LOCK position, and engage the parking brake.
2. Shut off the engine, remove the key, and wait for all moving parts to stop before leaving the operating position.
3. Check the upper tube, lower tube, bagger hood, and the blower assembly. Replace these parts if they are cracked or broken.
4. Check the bags, bagger frame, and screen. Replace any parts that are cracked or broken.
5. Tighten all nuts, bolts, and screws.

Inspecting the Mower Blades

1. Inspect the mower blades regularly and whenever a blade strikes a foreign object.
2. If blades are badly worn or damaged, install new blades. Refer to your machine *Operator's Manual* for complete blade maintenance.

Selecting the Mower Blades

In most mowing conditions, the standard high lift blades provide the best bagging performance.

The Toro Atomic blade is recommended for bagging leaves in dry conditions. In dry dusty conditions, the medium lift or low lift blades reduce dust and dirt blowout while providing effective bagging air flow.

Contact an Authorized Service Dealer for the proper blades for different mowing conditions.

Refer to the machines *Operator's Manual* for more information on installing blades.

Replacing the Grass Deflector

⚠ WARNING

An uncovered discharge opening could allow the machine to throw objects toward you or bystanders, resulting in serious injury. Also, contact with the blade could occur.

- Never operate the machine without a grass deflector, a mulch plate, or a bagger system installed.
- Ensure that the grass deflector is in the down position.

1. Place one end of the spring behind the deck edge and the other end on the grass deflector (Figure 43).

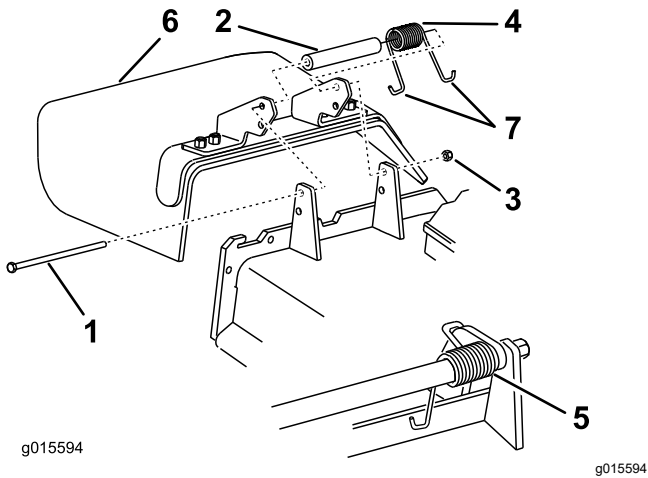

Figure 43

- | | |
|------------|---------------------|
| 1. Bolt | 5. Spring installed |
| 2. Spacer | 6. Grass deflector |
| 3. Locknut | 7. End of spring |
| 4. Spring | |

2. Use the bolt and nut to secure the grass deflector assembly to the mower deck (Figure 43).
3. Place the J-hook end of the spring around the grass deflector (Figure 43).

Important: The grass deflector must be able to lower down into position. Lift the deflector up to test that it lowers into the full-down position.

Storage

1. Empty the bagger attachment; refer to [Emptying the Grass Bags \(page 25\)](#).
2. Inspect the bagger attachment for damage.
3. Ensure that the bags are empty and thoroughly dry.
4. Inspect the belt for wear or cracks; refer to [Inspecting the Blower Belt \(page 29\)](#).
5. Store the machine in a clean, dry place, out of direct sunlight. If you must store the machine outside, cover it with a weatherproof cover. This protects the plastic parts and extends the life of the machine.

Troubleshooting

Problem	Possible Cause	Corrective Action
There is abnormal vibration.	<ol style="list-style-type: none"> 1. The cutting blade(s) is/are bent or unbalanced. 2. The blade mounting bolt is loose. 3. The blower pulley or pulley assembly is loose. 4. The blower belt is worn. 5. The blower fan blade(s) is/are bent or unbalanced. 	<ol style="list-style-type: none"> 1. Install new cutting blade(s). 2. Tighten the blade mounting bolt. 3. Tighten the appropriate pulley. 4. Replace the belt. 5. Contact an Authorized Service Dealer.
There is reduced bagging performance.	<ol style="list-style-type: none"> 1. The engine speed is low. 2. The bagger-hood screen is plugged. 3. The blower belt is loose. 4. The blower or tube is plugged. 5. The bags are full. 	<ol style="list-style-type: none"> 1. Always operate the bagger at full throttle. 2. Remove the debris, leaves or grass clippings from the screen. 3. Replace the bagger belt. 4. Locate and remove the plugged debris. 5. Empty the bags.
The blower and tubes plug too frequently.	<ol style="list-style-type: none"> 1. The engine speed is low. 2. The grass is too wet. 3. The grass is too long. 4. The screen in the hood is plugged. 5. The ground speed is too fast. 6. The bagger belt is worn. 	<ol style="list-style-type: none"> 1. Always operate the bagger at full throttle. 2. Cut the grass when it is dry. 3. Do not cut more than 51 to 76 mm (2 to 3 inches) or 1/3 of the grass height, which ever is less. 4. Remove the debris, leaves, or grass clippings from the screen. 5. Drive slower at full throttle. 6. Replace the belt.
There is debris blowout.	<ol style="list-style-type: none"> 1. The bags are full. 2. The ground speed is too fast. 3. The mower deck is not leveled. 	<ol style="list-style-type: none"> 1. Dump the bags more frequently. 2. Drive slower at full throttle. 3. See the mower <i>Operator's Manual</i> for leveling the mower deck.
The blower impeller does not spin freely.	<ol style="list-style-type: none"> 1. The blower is plugged. 2. The impeller is not aligned. 	<ol style="list-style-type: none"> 1. Remove the debris, leaves, or grass clippings from the blower impeller. 2. Contact an Authorized Service Dealer.

Notes:

Notes:

California Proposition 65 Warning Information

What is this warning?

You may see a product for sale that has a warning label like the following:



WARNING: Cancer and Reproductive Harm—www.p65Warnings.ca.gov.

What is Prop 65?

Prop 65 applies to any company operating in California, selling products in California, or manufacturing products that may be sold in or brought into California. It mandates that the Governor of California maintain and publish a list of chemicals known to cause cancer, birth defects, and/or other reproductive harm. The list, which is updated annually, includes hundreds of chemicals found in many everyday items. The purpose of Prop 65 is to inform the public about exposure to these chemicals.

Prop 65 does not ban the sale of products containing these chemicals but instead requires warnings on any product, product packaging, or literature with the product. Moreover, a Prop 65 warning does not mean that a product is in violation of any product safety standards or requirements. In fact, the California government has clarified that a Prop 65 warning "is not the same as a regulatory decision that a product is 'safe' or 'unsafe.'" Many of these chemicals have been used in everyday products for years without documented harm. For more information, go to <https://oag.ca.gov/prop65/faqs-view-all>.

A Prop 65 warning means that a company has either (1) evaluated the exposure and has concluded that it exceeds the "no significant risk level"; or (2) has chosen to provide a warning based on its understanding about the presence of a listed chemical without attempting to evaluate the exposure.

Does this law apply everywhere?

Prop 65 warnings are required under California law only. These warnings are seen throughout California in a wide range of settings, including but not limited to restaurants, grocery stores, hotels, schools, and hospitals, and on a wide variety of products. Additionally, some online and mail order retailers provide Prop 65 warnings on their websites or in catalogs.

How do the California warnings compare to federal limits?

Prop 65 standards are often more stringent than federal and international standards. There are various substances that require a Prop 65 warning at levels that are far lower than federal action limits. For example, the Prop 65 standard for warnings for lead is 0.5 µg/day, which is well below the federal and international standards.

Why don't all similar products carry the warning?

- Products sold in California require Prop 65 labelling while similar products sold elsewhere do not.
- A company involved in a Prop 65 lawsuit reaching a settlement may be required to use Prop 65 warnings for its products, but other companies making similar products may have no such requirement.
- The enforcement of Prop 65 is inconsistent.
- Companies may elect not to provide warnings because they conclude that they are not required to do so under Prop 65; a lack of warnings for a product does not mean that the product is free of listed chemicals at similar levels.

Why does Toro include this warning?

Toro has chosen to provide consumers with as much information as possible so that they can make informed decisions about the products they buy and use. Toro provides warnings in certain cases based on its knowledge of the presence of one or more listed chemicals without evaluating the level of exposure, as not all the listed chemicals provide exposure limit requirements. While the exposure from Toro products may be negligible or well within the "no significant risk" range, out of an abundance of caution, Toro has elected to provide the Prop 65 warnings. Moreover, if Toro does not provide these warnings, it could be sued by the State of California or by private parties seeking to enforce Prop 65 and subject to substantial penalties.



Count on it.