



**Count on it.**

**Operator's Manual**

# 21in Heavy-Duty Recycler<sup>®</sup>/Rear Bagger Lawn Mower

Model No. 22296—Serial No. 402020000 and Up

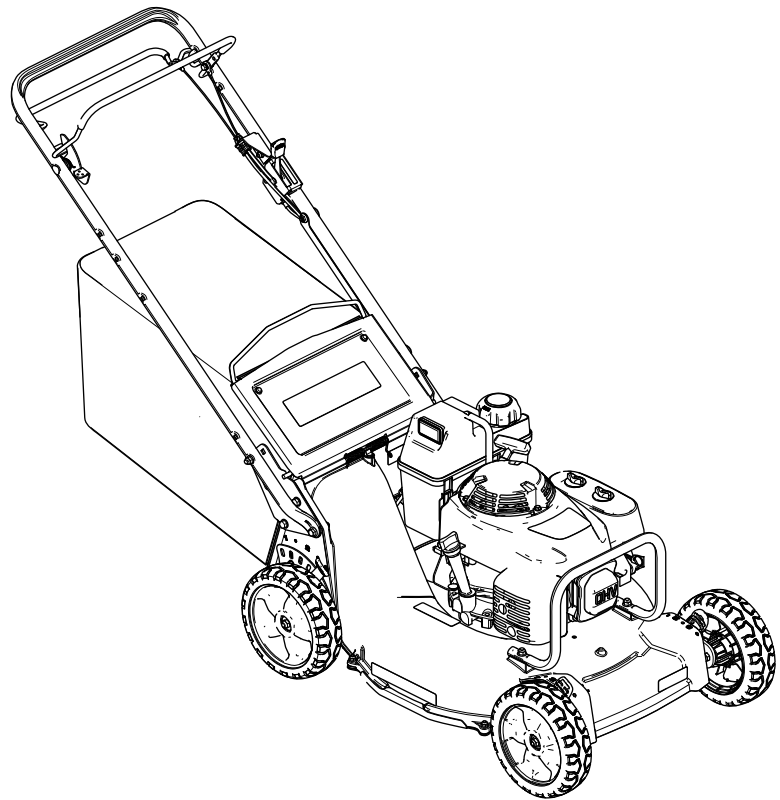

It is a violation of California Public Resource Code Section 4442 or 4443 to use or operate the engine on any forest-covered, brush-covered, or grass-covered land unless the engine is equipped with a spark arrester, as defined in Section 4442, maintained in effective working order or the engine is constructed, equipped, and maintained for the prevention of fire.

**Gross or Net Torque:** The gross or net torque of this engine was laboratory rated by the engine manufacturer in accordance with the Society of Automotive Engineers (SAE) J1940 or J2723. As configured to meet safety, emission, and operating requirements, the actual engine torque on this class of mower will be significantly lower. Please refer to the engine manufacturer's information included with the machine.

**⚠ WARNING**

**CALIFORNIA  
Proposition 65 Warning**

**The engine exhaust from this product contains chemicals known to the State of California to cause cancer, birth defects, or other reproductive harm.**

**Use of this product may cause exposure to chemicals known to the State of California to cause cancer, birth defects, or other reproductive harm.**

# Introduction

This rotary-blade, walk-behind lawn mower is intended to be used by residential homeowners or professional, hired operators. It is designed primarily for cutting grass on well-maintained lawns on residential or commercial properties. It is not designed for cutting brush or for agricultural uses.

Read this information carefully to learn how to operate and maintain your product properly and to avoid injury and product damage. You are responsible for operating the product properly and safely.

You may contact Toro directly at [www.Toro.com](http://www.Toro.com) for product and accessory information, help finding a dealer, or to register your product.

Whenever you need service, genuine Toro parts, or additional information, contact an Authorized Service Dealer or Toro Customer Service and have the model and serial numbers of your product ready. **Figure 1** identifies the location of the model and serial numbers

on the product. Write the numbers in the space provided.

**Important:** With your mobile device, you can scan the QR code on the serial number decal (if equipped) to access warranty, parts, and other product information.

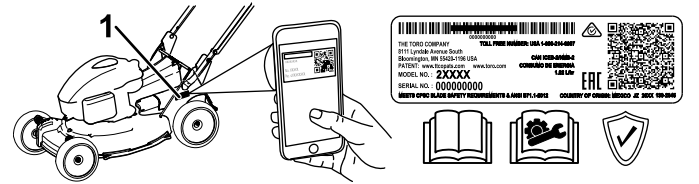

**Figure 1**

1. Model and serial number location

Model No. \_\_\_\_\_

Serial No. \_\_\_\_\_

This manual identifies potential hazards and has safety messages identified by the safety-alert symbol (**Figure 2**), which signals a hazard that may cause serious injury or death if you do not follow the recommended precautions.



**Figure 2**  
Safety-alert symbol

This manual uses 2 words to highlight information. **Important** calls attention to special mechanical information and **Note** emphasizes general information worthy of special attention.

# Contents

Safety .....	3
General Safety .....	3
Safety and Instructional Decals .....	4
Setup .....	6
1 Removing the Cable Guard .....	6
2 Installing the Handle .....	6
3 Installing the Cable Guard .....	7
4 Filling the Engine with Oil .....	8
5 Assembling the Grass Bag .....	9
6 Adjusting the Self-Propel Drive .....	10
Product Overview .....	11
Before Operation .....	12
Before Operation Safety .....	12

# Safety

This machine has been designed in accordance with ANSI B71.1-2012.

## General Safety

This product is capable of amputating hands and feet and of throwing objects. Always follow all safety instructions to avoid serious personal injury.

Using this product for purposes other than its intended use could prove dangerous to you and bystanders.

- Read, understand, and follow the instructions and warnings in this *Operator's Manual* and on the machine and attachments before starting the engine.
- Do not put your hands or feet near moving parts of or under the machine. Keep clear of any discharge opening.
- Do not operate the machine without all guards and other safety protective devices in place and working on the machine.
- Keep bystanders and children a safe distance away from the machine. Do not allow children to operate the machine. Allow only people who are responsible, trained, familiar with the instructions, and physically capable to operate the machine.
- Stop the machine, shut off the engine, and wait for all moving parts to stop before servicing, fueling, or unclogging the machine.

Improperly using or maintaining this machine can result in injury. To reduce the potential for injury, comply with these safety instructions and always pay attention to the safety-alert symbol, which means Caution, Warning, or Danger—personal safety instruction. Failure to comply with these instructions may result in personal injury or death.

You can find additional safety information where needed throughout this manual.

Filling the Fuel Tank .....	12
Checking the Engine-Oil Level .....	13
Adjusting the Cutting Height .....	14
During Operation .....	14
During Operation Safety .....	14
Starting the Engine .....	15
Shutting Off the Engine .....	16
Operating the Self-Propel Drive and Engaging the Blades .....	16
Checking the Blade-Brake Clutch .....	17
Recycling the Clippings .....	18
Bagging the Clippings .....	18
Operating Tips .....	20
After Operation .....	20
After Operation Safety .....	20
Cleaning under the Machine .....	21
Maintenance .....	22
Recommended Maintenance Schedule(s) .....	22
Maintenance Safety .....	22
Servicing the Air Filter .....	23
Changing the Engine Oil .....	23
Servicing the Spark Plug .....	24
Adjusting the Self-Propel Drive .....	24
Maintaining the Blade .....	25
Adjusting the Blade-Brake Cable .....	27
Cleaning under the Belt Cover .....	28
Cleaning the Blade-Brake-Clutch Shield .....	28
Cleaning the Wheels .....	29
Storage .....	30
Preparing the Fuel System .....	30
Preparing the Engine .....	30
General Information .....	30
Removing the Machine from Storage .....	30
Troubleshooting .....	31

# Safety and Instructional Decals



Safety decals and instructions are easily visible to the operator and are located near any area of potential danger. Replace any decal that is damaged or missing.

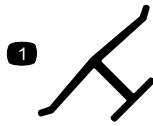

decaloemmark

## Manufacturer's Mark

1. This mark indicates that the blade is identified as a part from the original machine manufacturer.



decal94-8072

94-8072



decal116-7583

116-7583

1. Warning—read the *Operator's Manual*. Do not operate this machine unless you are trained.
2. Thrown object hazard—keep bystanders a safe distance away from the machine.
3. Thrown object hazard—do not operate the machine without the rear-discharge plug or bag in place.
4. Cutting/dismemberment hazard of hand or foot, mower blade—stay away from moving parts; keep all guards in place.
5. Warning—wear hearing protection.
6. Cutting/dismemberment hazard of hand or foot, mower blade—do not operate up and down slopes; operate side to side on slopes; shut off the engine before leaving the operating position—pick up objects that the blades could throw; and look behind you when backing up.

## CALIFORNIA SPARK ARRESTER WARNING

Operation of this equipment may create sparks that can start fires around dry vegetation. A spark arrester may be required. The operator should contact local fire agencies for laws or regulations relating to fire prevention requirements.

117-2718

decal117-2718

117-2718

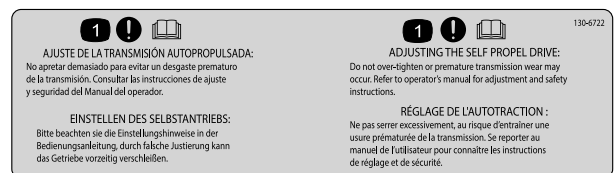

130-6722

130-6722

decal130-6722

1. Attention—read the *Operator's Manual*.



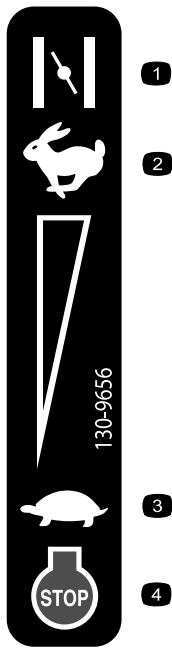

decal130-9656

**130-9656**

- |          |                           |
|----------|---------------------------|
| 1. Choke | 3. Slow                   |
| 2. Fast  | 4. Engine—stop (shut off) |

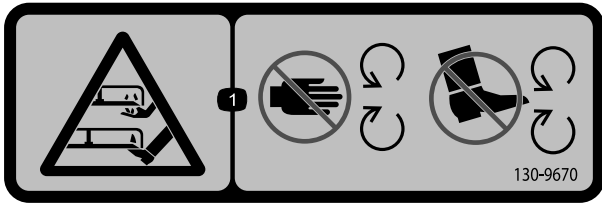

decal130-9670

**130-9670**

1. Severing hazard of hand or foot; mower blade—keep away from moving parts.

# Setup

**Important:** Remove and discard the protective plastic sheet that covers the engine and any other plastic or wrapping on the machine.

**1**

## Removing the Cable Guard

No Parts Required

### Procedure

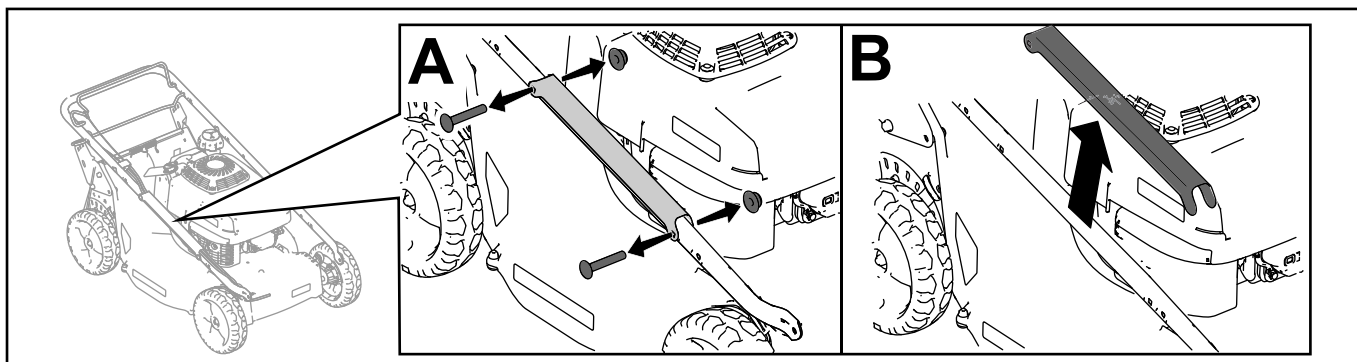

Figure 3

g234471

# 2

## Installing the Handle

No Parts Required

### Procedure

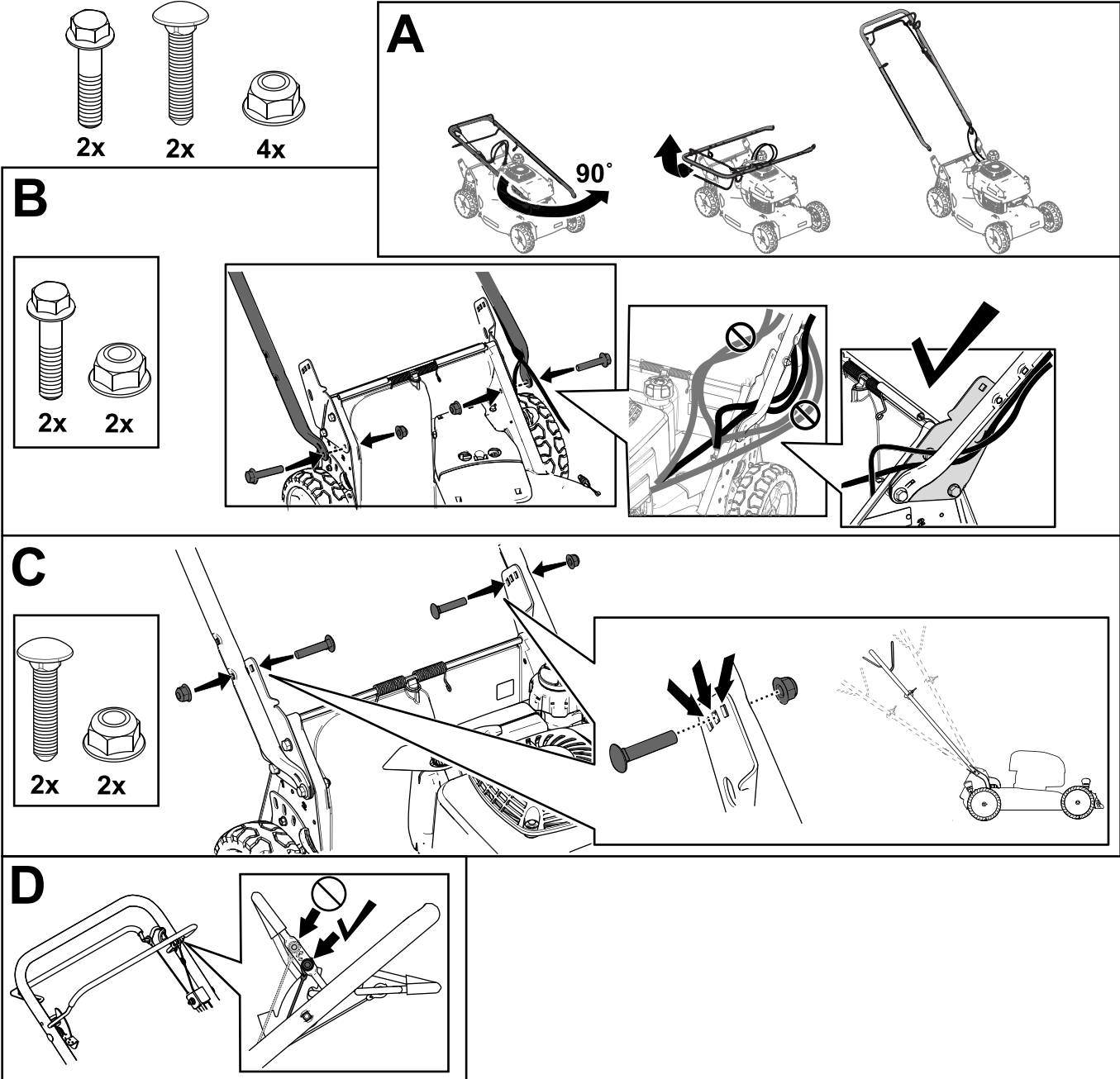

Figure 4

g235723

# 3

## Installing the Cable Guard

No Parts Required

### Procedure

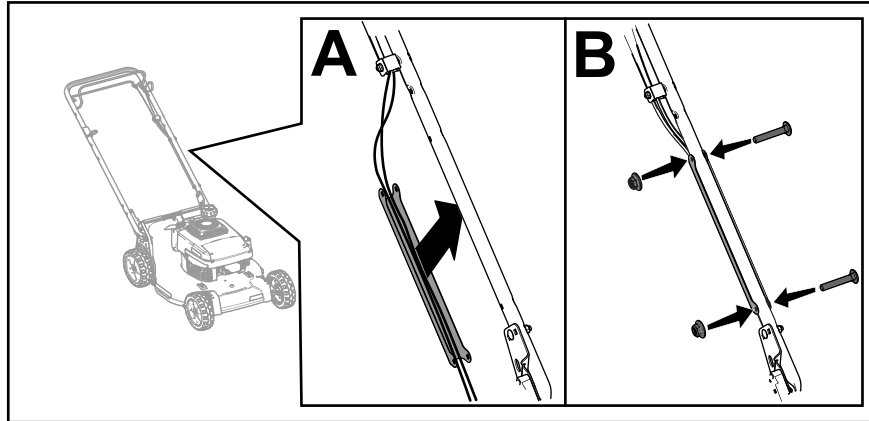

Figure 5

g234486

# 4

## Filling the Engine with Oil

No Parts Required

### Procedure

**Important:** Your machine does not come with oil in the engine. Before starting the engine, fill the engine with oil.

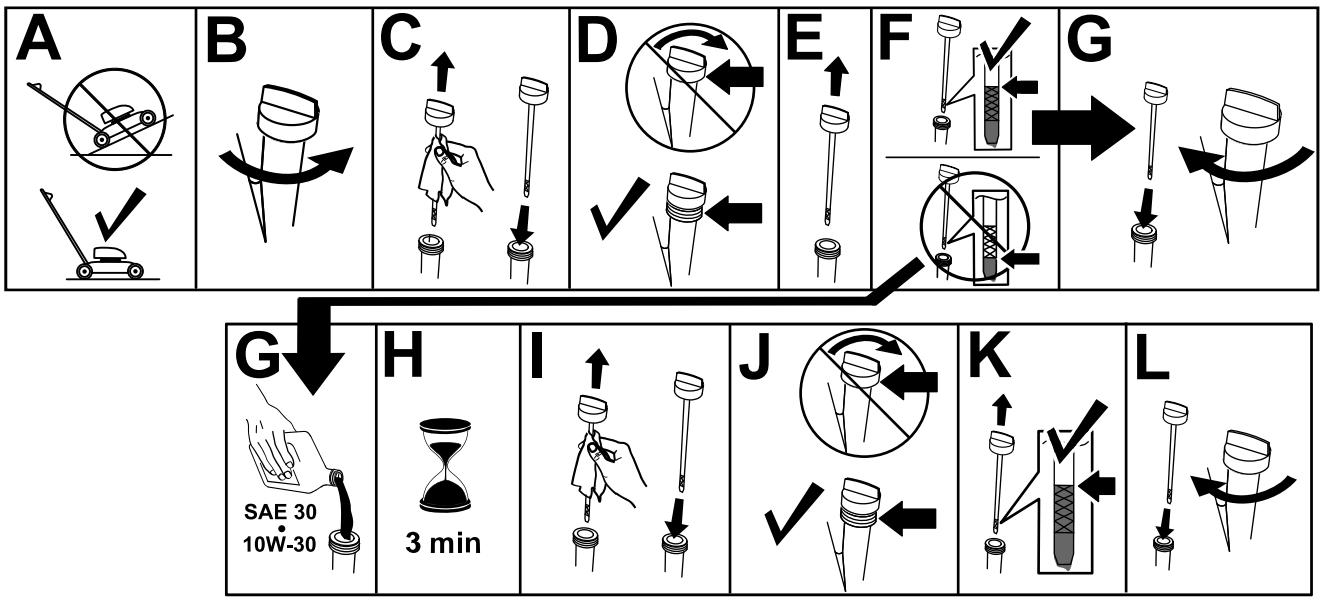

Figure 6

g235721

# 5

## Assembling the Grass Bag

No Parts Required

### Procedure

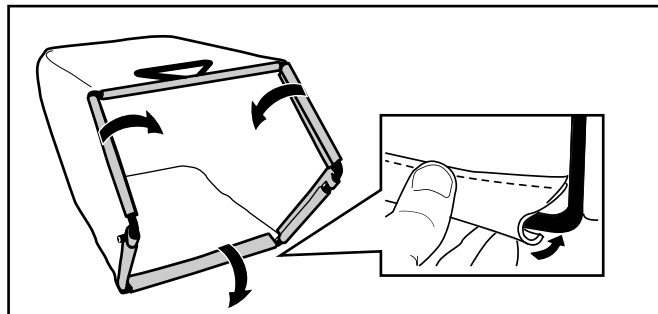

Figure 7

g238450

# 6

## Adjusting the Self-Propel Drive

No Parts Required

### Procedure

*Important:* You must adjust the self-propel-drive cable before you operate the machine for the first time. Refer to [Adjusting the Self-Propel Drive \(page 24\)](#).

# Product Overview

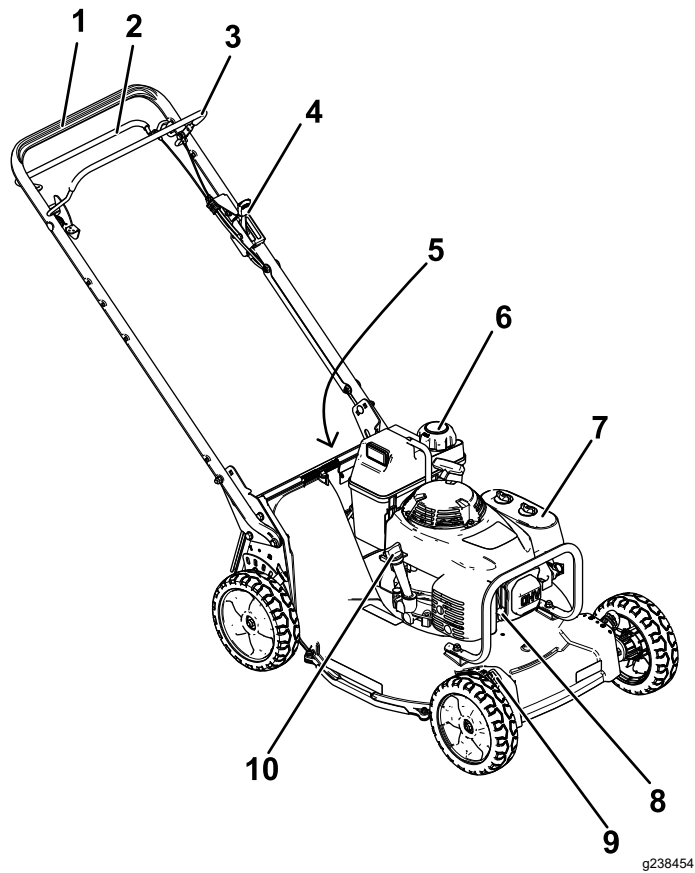

**Figure 8**

g238454

- |                               |                             |
|-------------------------------|-----------------------------|
| 1. Handle                     | 6. Fuel-tank cap            |
| 2. Self-propel-drive bar      | 7. Air cleaner              |
| 3. Blade-control bar          | 8. Spark plug               |
| 4. Throttle                   | 9. Cutting-height lever (4) |
| 5. Rear deflector (not shown) | 10. Oil fill/dipstick       |

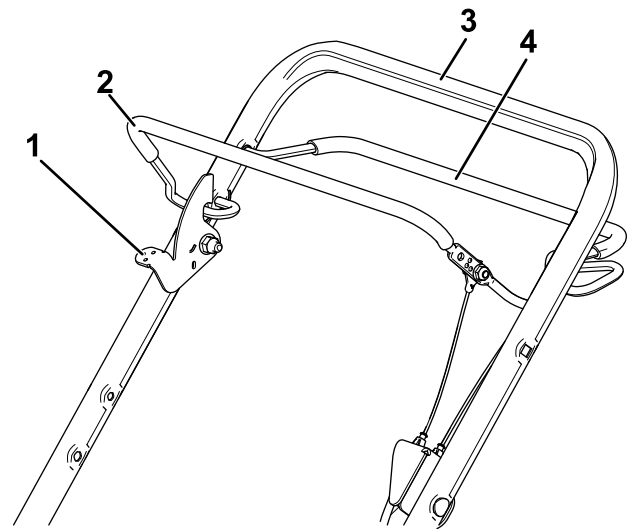

g231779

**Figure 10**

- |                             |               |
|-----------------------------|---------------|
| 1. Blade-control lock-lever | 3. Handle     |
| 2. Blade-control bar        | 4. Drive bail |

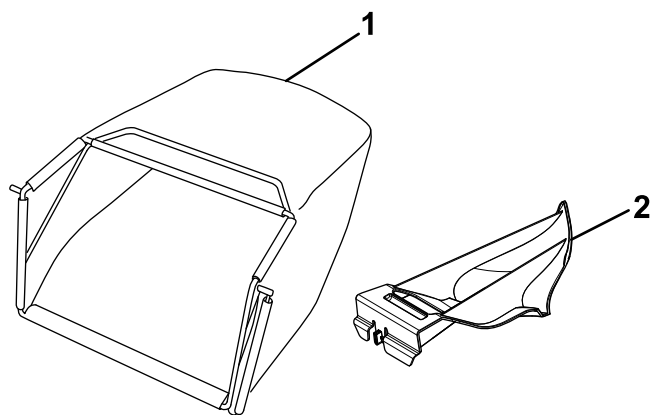

g231061

**Figure 9**

- |              |                        |
|--------------|------------------------|
| 1. Grass bag | 2. Rear-discharge plug |
|--------------|------------------------|

# Operation

**Note:** Determine the left and right sides of the machine from the normal operating position.

## Before Operation

## Before Operation Safety

### General Safety

- Become familiar with the safe operation of the equipment, operator controls, and safety signs.
- Check that all guards and safety devices, such as deflectors and/or grass catcher, are in place and working properly.
- Always inspect the machine to ensure that the blades, blade bolts, and cutting assembly are not worn or damaged.
- Inspect the area where you will use the machine, and remove all objects that could interfere with the operation of the machine or that the machine could throw.
- Adjusting the cutting height may bring you into contact with the moving blade, causing serious injury.
  - Shut off the engine, remove the ignition key (electric-start model only), and wait for all moving parts to stop.
  - Do not put your fingers under the housing when adjusting the cutting height.

### Fuel Safety

- Fuel is extremely flammable and highly explosive. A fire or explosion from fuel can burn you and others and can damage property.
  - To prevent a static charge from igniting the fuel, place the container and/or machine directly on the ground before filling, not in a vehicle or on an object.
  - Fill the fuel tank outdoors, in an open area, when the engine is cold. Wipe up any fuel that spills.
  - Do not handle fuel when smoking or around an open flame or sparks.
  - Do not remove the fuel cap or add fuel to the tank while the engine is running or hot.
  - If you spill fuel, do not attempt to start the engine. Avoid creating a source of ignition until the fuel vapors have dissipated.

- Store fuel in an approved container and keep it out of the reach of children.
- Fuel is harmful or fatal if swallowed. Long-term exposure to vapors can cause serious injury and illness.
  - Avoid prolonged breathing of vapors.
  - Keep your hands and face away from the nozzle and the fuel-tank opening.
  - Keep fuel away from your eyes and skin.

## Filling the Fuel Tank

### **⚠ DANGER**

**Gasoline is extremely flammable and explosive. A fire or explosion from gasoline can burn you and others.**

- **To prevent a static charge from igniting the gasoline, place the container and/or machine directly on the ground before filling, not in a vehicle or on an object.**
- **Fill the tank outdoors when the engine is cold. Wipe up spills.**
- **Do not handle gasoline when smoking or around an open flame or sparks.**
- **Store gasoline in an approved fuel container, out of the reach of children.**
- For best results, use only clean, fresh (less than 30 days old), unleaded gasoline with an octane rating of 87 or higher ((R+M)/2 rating method).
- Oxygenated fuel with up to 10% ethanol or 15% MTBE by volume is acceptable.
- **Ethanol:** Gasoline with up to 10% ethanol (gasohol) or 15% MTBE (methyl tertiary butyl ether) by volume is acceptable. Ethanol and MTBE are not the same. Gasoline with 15% ethanol (E15) by volume is not approved for use. **Never use gasoline that contains more than 10% ethanol by volume**, such as E15 (contains 15% ethanol), E20 (contains 20% ethanol), or E85 (contains up to 85% ethanol). Using unapproved gasoline may cause performance problems and/or engine damage which may not be covered under warranty.
- **Do not** use gasoline containing methanol.
- **Do not** store fuel either in the fuel tank or in fuel containers over the winter unless you use a fuel stabilizer.
- **Do not** add oil to gasoline.



**Important:** To reduce starting problems, add fuel stabilizer/conditioner to fresh fuel as directed by the fuel-stabilizer manufacturer.

**Note:** The capacity of the fuel tank is 3.76 L (0.99 US gallon).

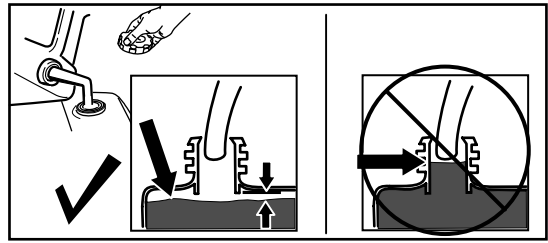

g230458

Figure 11

## Checking the Engine-Oil Level

**Service Interval:** Before each use or daily

**Important:** If the oil level in the engine is too low or too high and you run the engine, you may damage the engine.

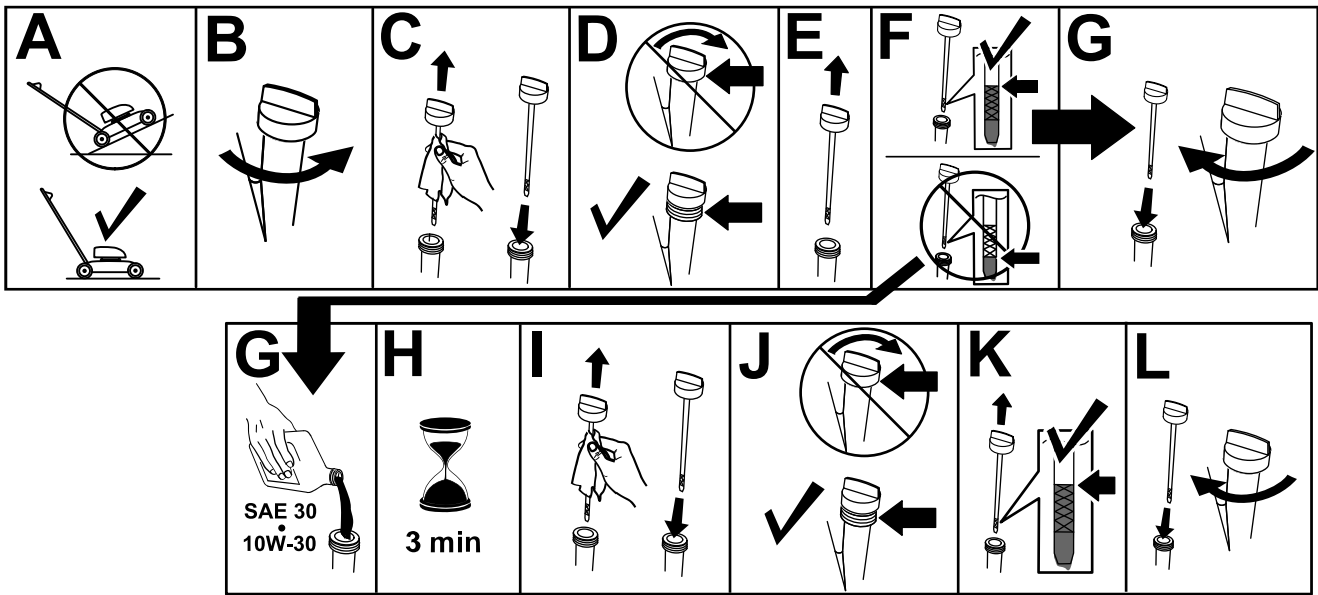

g235721

Figure 12

# Adjusting the Cutting Height

## **⚠ DANGER**

Adjusting the cutting-height levers could bring your hands into contact with a moving blade and result in serious injury.

- Shut off the engine and wait for all movement to stop before adjusting the cutting height.
- Do not put your fingers under the housing when adjusting the cutting height.

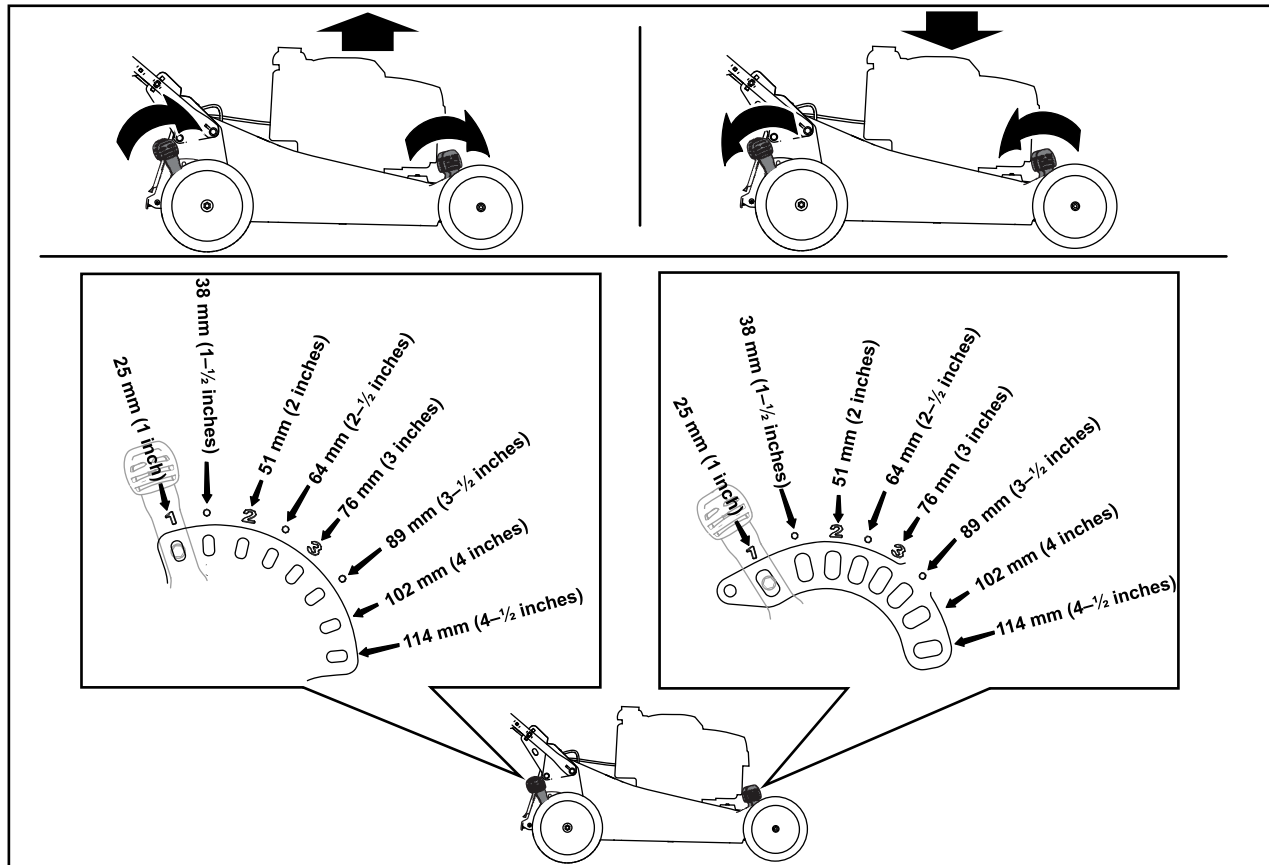

Figure 13

g234297

## ***During Operation***

### **During Operation Safety**

#### **General Safety**

- Wear appropriate clothing, including eye protection; long pants; slip-resistant, substantial footwear; and hearing protection. Tie back long hair, secure loose clothing, and do not wear loose jewelry.
- Do not operate the machine while ill, tired, or under the influence of alcohol or drugs.
- The blade is sharp; contacting the blade can result in serious personal injury. Shut off the engine, remove the ignition key (electric-start model only),

and wait for all moving parts to stop before leaving the operating position.

- When you release the blade-control bar, the engine should shut off and the blade should stop within 3 seconds. If not, stop using your machine immediately and contact an Authorized Service Dealer.
- Keep bystanders, especially small children, out of the operating area. Stop the machine if anyone enters the area.
- Always look down and behind you before moving the machine in reverse.
- Operate the machine only in good visibility and appropriate weather conditions. Do not operate the machine when there is the risk of lightning.

- Wet grass or leaves can cause serious injury if you slip and contact the blade. Avoid mowing in wet conditions.
- Use extreme care when approaching blind corners, shrubs, trees, or other objects that may block your view.
- Watch for holes, ruts, bumps, rocks, or other hidden objects. Uneven terrain could cause the machine to overturn or cause you to lose your balance or footing.
- If the machine strikes an object or starts to vibrate, immediately shut off the engine, remove the key (if equipped), wait for all moving parts to stop, and disconnect the wire from the spark plug before examining the machine for damage. Make all necessary repairs before resuming operation.
- Before leaving the operating position, shut off the engine, remove the ignition key (electric-start model only), and wait for all moving parts to stop.
- If the engine has been running the muffler will be hot and can severely burn you. Keep away from the hot muffler.
- Check the grass catcher components and the discharge chute frequently for any wear or deterioration and replace them with the manufacturer's recommended parts when necessary.
- Use accessories and attachments approved by The Toro® Company only.

## Slope Safety

- Mow across the face of slopes; never up and down. Use extreme caution when changing direction on slopes.
- Do not mow on excessively steep slopes. Poor footing could cause a slip-and-fall accident.
- Mow with caution near drop-offs, ditches, or embankments.

## Starting the Engine

1. Connect the spark-plug wire to the spark plug.
2. Open the fuel valve by moving the fuel-valve lever to the **right** (Figure 14).

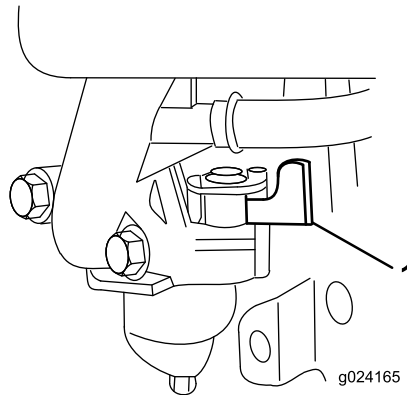

Figure 14

g024165

1. Fuel-valve lever

3. Move the throttle-control lever to the CHOKE position (A of Figure 15).

**Note:** Do not use the choke when the engine is warm.

4. Pull the starter handle lightly until you feel resistance, then pull it sharply (B of Figure 15).

**Note:** Allow the rope to return slowly to the rope guide on the handle.

5. When the engine starts, move the throttle-control lever to the FAST position (C of Figure 15).

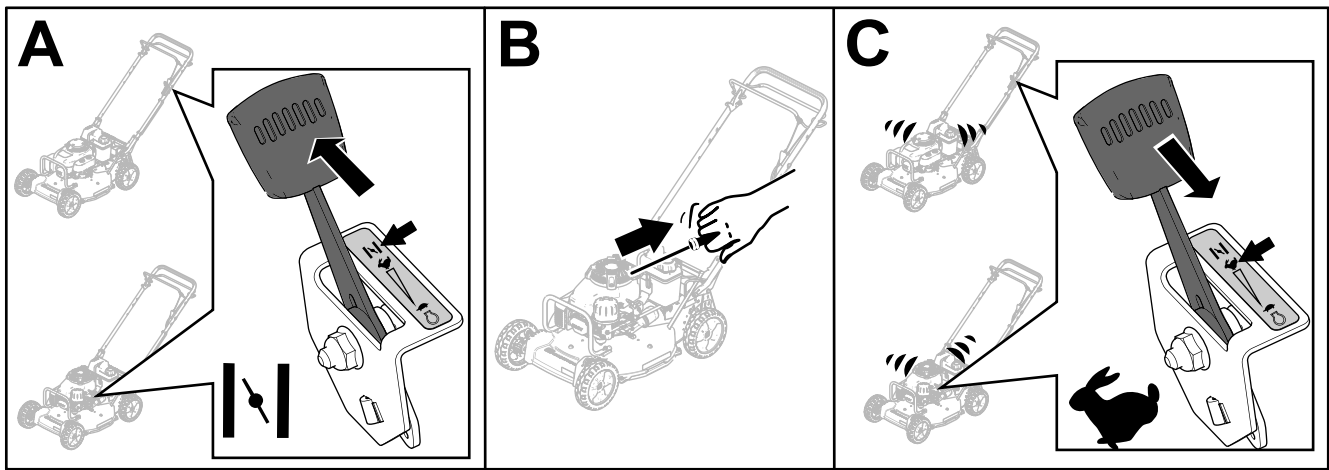

Figure 15

g234784

## Shutting Off the Engine

Release the blade-control bar and move the throttle-control lever to the STOP position.

**Note:** Close the fuel valve by moving the fuel-valve lever (Figure 14) to the **left** if you will not be starting the engine soon afterward.

## Operating the Self-Propel Drive and Engaging the Blades

This machine has 3 ground speeds: 1 (slow), 2 (medium), and 3 (fast); it also has a Neutral (N) position. The self-propel-drive lever is located below and behind the fuel tank (Figure 16).

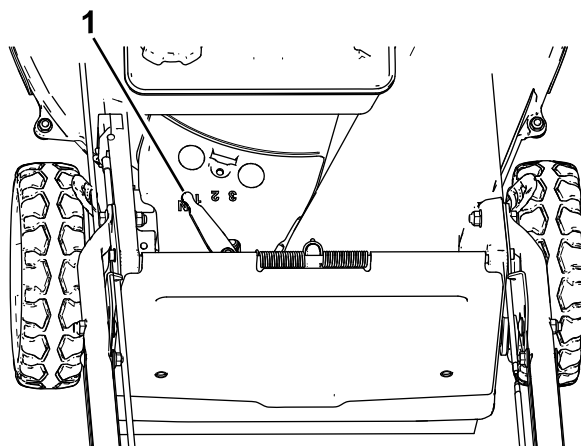

Figure 16

g024167

g024167

1. Self-propel-drive lever

2. Start the engine.
3. To operate the self-propel drive, squeeze the drive bail (Figure 17).

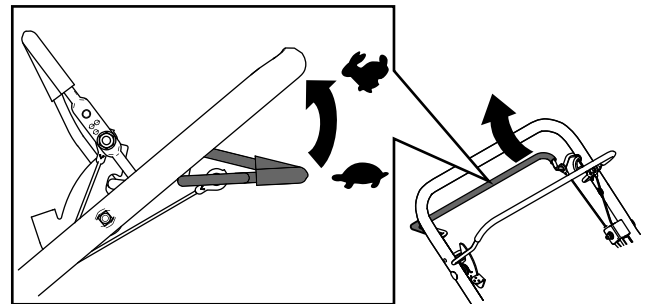

Figure 17

g238895

**Note:** You can vary the ground speed by increasing or decreasing the distance between the blade-control bar and the handle.

1. Move the self-propel-drive lever to the desired ground speed.

To engage the blades, do the following:

1. Push and hold the blade-control lock lever forward to release the blade-control bail (A of [Figure 18](#)).
2. Pull the blade-control bail to the handle and release the blade-control-lock lever; the blade should engage (A of [Figure 18](#)).
3. Release the blade-control bail to disengage the blade (B of [Figure 18](#)). The blade-control-lock lever resets to lock the blade-control bail.

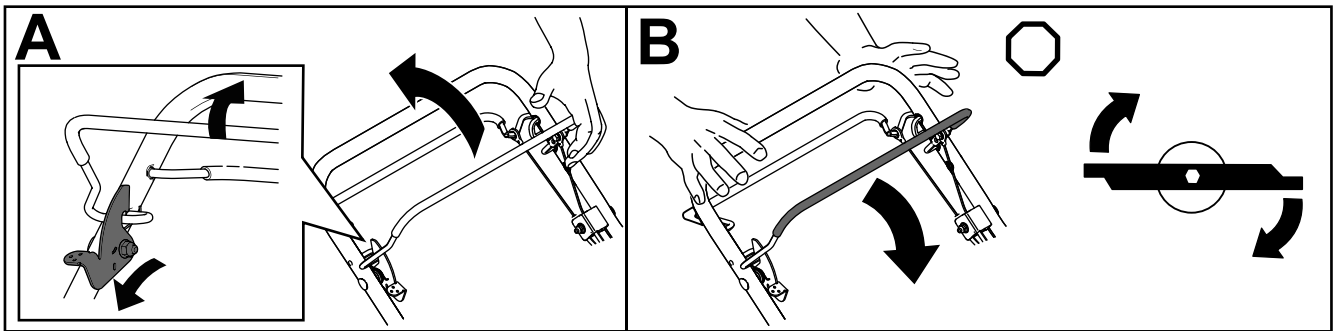

Figure 18

g237185

## Checking the Blade-Brake Clutch

Check the blade-control bar before each use to ensure that the blade-brake clutch is operating properly.

### Checking with the Grass Bag

1. Install the empty grass bag on the machine.
2. Start the engine.
3. Engage the blade.  
**Note:** The bag should begin to inflate, indicating that the blade is engaged and rotating.
4. Release the blade-control bar.  
**Note:** If the bag does not immediately deflate, the blade is still rotating. The blade-brake clutch may be deteriorating and, if ignored, could result in an unsafe operating condition. Have the machine inspected and serviced by an Authorized Service Dealer.
5. Shut off the engine and wait for all moving parts to stop.

### Checking without the Grass Bag

1. Move the machine onto a paved surface in a non-windy area.
2. Set all 4 wheels to the 76 mm (3 inch) cutting-height setting; refer to [Adjusting the Cutting Height \(page 14\)](#).
3. Take a half sheet of newspaper and crumple it into a ball small enough to go under the machine housing (about 76 mm or 3 inches in diameter).

4. Place the newspaper ball about 13 cm (5 inches) in front of the machine.
5. Start the engine.
6. Engage the blade.
7. Release the blade-control bar.
8. Immediately push the machine over the newspaper ball.
9. Shut off the engine and wait for all moving parts to stop.
10. Go to the front of the machine and check the newspaper ball.

**Note:** If the newspaper ball did not go under the machine, repeat steps 4 through 10.

**Note:** If the newspaper is unravelled or shredded, the blade did not stop properly, which could result in an unsafe operating condition. Contact an Authorized Service Dealer.

# Recycling the Clippings

This machine comes from the factory ready to recycle grass and leaf clippings back into the lawn. To prepare the machine to recycle:

- If the grass bag is on the machine, remove it (A of [Figure 19](#)).
- If the rear-discharge plug is not installed, grip it by the handle, raise the rear deflector, and insert it into the rear-discharge chute until the latch locks into place (B of [Figure 19](#)).

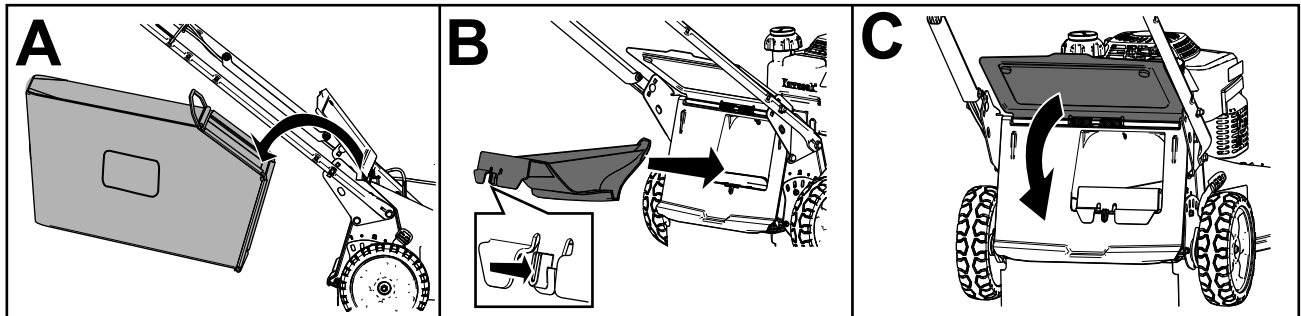

Figure 19

g236734

## **⚠ WARNING**

Operating the machine to recycle lawn clippings without the plug in place allows objects to be thrown toward you or bystanders. Also, contact with the blades could occur. Thrown objects or blade contact can cause serious injury or death.

Ensure that the rear-discharge plug is in place before you recycle the clippings. Never engage the blades without either the rear-discharge plug or the grass bag installed on the machine.

## Bagging the Clippings

Use the grass bag when you want to collect grass and leaf clippings from the lawn.

## **⚠ WARNING**

A worn grass bag could allow small stones and other similar debris to be thrown toward you or bystanders, resulting in serious personal injury or death.

Check the grass bag frequently. If it is damaged, install a new Toro replacement bag.

## **⚠ WARNING**

The blades are sharp; contacting the blades can result in serious personal injury.

Shut off the engine and wait for all moving parts to stop before leaving the operating position.

## Installing the Grass Bag

1. Shut off the engine and wait for all moving parts to stop.
2. Raise and hold up the rear deflector (A of [Figure 20](#)).
3. Remove the rear-discharge plug by pushing in the latch with your thumb and pulling the plug out from the machine (B and C of [Figure 20](#)).
4. Install the bag-rod ends into the notches at the base of the handle, and rock the bag back and forth to ensure that the bag-rod ends are seated at the bottom of both notches (D of [Figure 20](#)).
5. Lower the rear deflector until it rests on the grass bag.

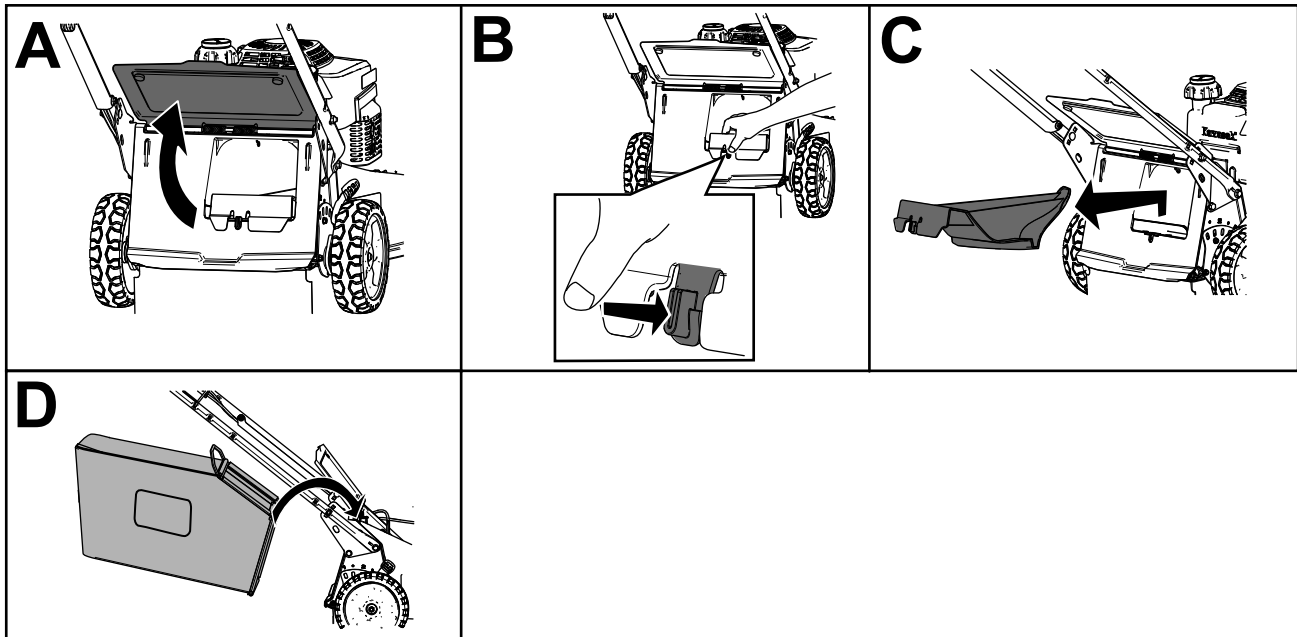

Figure 20

g236745

## Removing the Grass Bag

### **⚠ DANGER**

The machine can throw grass clippings and other objects through an opening in the machine housing. Objects thrown with enough force could cause serious personal injury or death to you or to bystanders.

- Never remove the grass bag and then start the engine without the discharge plug installed on the machine.
  - Never open the rear deflector on the machine when the engine is running.
1. Shut off the engine and wait for all moving parts to stop.
  2. Raise the rear deflector.
  3. Remove the bag rod on the grass bag from the notches at the base of the handle (A of [Figure 19](#)).
  4. Install the discharge plug (B of [Figure 19](#)).
  5. Lower the rear deflector (C of [Figure 19](#)).



# Operating Tips

## General Tips

- Review the safety instructions and read this manual carefully before operating the machine.
- Clear the area of sticks, stones, wire, branches, and other debris that the blade could hit and throw.
- Keep everyone, especially children and pets, away from the area of operation.
- Avoid striking trees, walls, curbs, or other solid objects. Never deliberately mow over any object.
- If the machine strikes an object or starts to vibrate, immediately shut off the engine, disconnect the wire from the spark plug, and examine the machine for damage.
- Maintain a sharp blade throughout the cutting season. Periodically file down nicks on the blade.
- Replace the blade when necessary with an original Toro replacement blade.
- Mow only dry grass or leaves. Wet grass and leaves tend to clump on the yard and can cause the machine to plug or the engine to stall.

### **⚠ WARNING**

**Wet grass or leaves can cause serious injury if you slip and contact the blade.**

**Mow only in dry conditions.**

- Clean under the machine after each mowing; refer to [Cleaning under the Machine \(page 21\)](#).
- Keep the engine in good running condition.
- Clean the air filter frequently. Mulching stirs up more clippings and dust which clogs the air filter and reduces engine performance.
- Set the engine speed to the fastest position for the best cutting results.

### **⚠ WARNING**

**Operating a machine with its engine running at a speed greater than the factory setting can cause the machine to throw a part of the blade or engine toward you or bystanders, resulting in serious personal injury or death.**

- **Do not change the engine speed setting.**
- **If you suspect the engine speed is faster than normal, contact an Authorized Service Dealer.**

## Cutting Grass

- Grass grows at different rates at different times of the year. In the summer heat, it is best to cut

grass at the 64 mm (2-1/2 inch), 76 mm (3 inch), or 89 mm (3-1/2 inch) cutting-height settings. Cut only about a third of the grass blade at a time. Do not cut below the 64 mm (2-1/2 inch) setting unless the grass is sparse or it is late fall when grass growth begins to slow down.

- When cutting grass over 15 cm (6 inches) tall, first mow at the highest cutting-height setting and walk slower; then mow again at a lower setting for the best lawn appearance. If the grass is too long and the leaves clump on top of the lawn, the machine may plug and cause the engine to stall.
- Alternate the mowing direction. This helps disperse the clippings over the lawn for even fertilization.

If the finished lawn appearance is unsatisfactory, try 1 or more of the following:

- Sharpen the blade.
- Walk at a slower pace while mowing.
- Raise the cutting height on your machine.
- Cut the grass more frequently.
- Overlap cutting swaths instead of cutting a full swath with each pass.

## Cutting Leaves

- After cutting the lawn, ensure that half of the lawn shows through the cut leaf cover. You may need to make more than a single pass over the leaves.
- For light leaf coverage, set all the wheels at the same cutting-height setting.
- Slow down your mowing speed if the machine does not cut the leaves finely enough.

## After Operation

### After Operation Safety

#### General Safety

- Clean grass and debris from the machine to help prevent fires. Clean up oil or fuel spills.
- Allow the engine to cool before storing the machine in any enclosure.
- Never store the machine or fuel container where there is an open flame, spark, or pilot light, such as on a water heater or on other appliances.

#### Hauling Safety

- Remove the ignition key (if equipped) before loading the machine for hauling.



- Use care when loading or unloading the machine.
- Secure the machine from rolling.

## Cleaning under the Machine

To ensure the best performance, keep the underside of the machine clean. Be especially careful to keep the kickers free of debris (Figure 21).

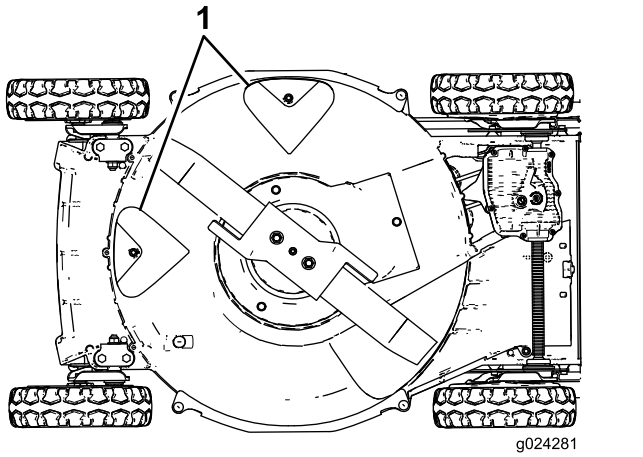

Figure 21

1. Kickers

## Washing Method

Service Interval: Before each use or daily

### ⚠ WARNING

The machine may dislodge material from under the machine.

- Wear eye protection.
- Stay in the operating position (behind the handle) while the engine is running.
- Do not allow bystanders in the area.

1. Move the machine to a paved level surface near a garden hose.
2. Start the engine.
3. Hold the running garden hose at handle level and direct the water to flow on the ground just in front of the right, rear wheel (Figure 22).

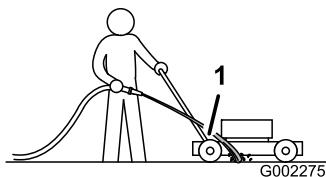

Figure 22

1. Right, rear wheel

**Note:** The blade will draw in water and wash out the clippings. Let the water run until you no longer see clippings being washed out from under the machine.

4. Shut off the engine and wait for all moving parts to stop.
5. Turn off the water.
6. Start the machine and let it run for a few minutes to dry out the underside of the machine.

## Scraping Method

If washing does not remove all debris from under the machine, scrape it clean.

1. Disconnect the wire from the spark plug (Figure 8).
2. Drain the fuel from the fuel tank.

### ⚠ WARNING

Tipping the machine may cause the fuel to leak from the carburetor or the fuel tank. Fuel is extremely flammable, highly explosive, and, under certain conditions, can cause personal injury or property damage.

Avoid fuel spills by running the engine dry or by removing the fuel with a hand pump; never siphon.

3. Tip the machine onto its **right** side (air cleaner up).
4. Remove the dirt and grass clippings with a hardwood scraper. Avoid burrs and sharp edges.
5. Return the machine to the operating position.
6. Connect the wire to the spark plug.

# Maintenance

## Recommended Maintenance Schedule(s)

Maintenance Service Interval	Maintenance Procedure
After the first 8 hours	<ul style="list-style-type: none"> <li>• Change the engine oil.</li> </ul>
After the first 25 hours	<ul style="list-style-type: none"> <li>• Tighten any loose fasteners.</li> </ul>
Before each use or daily	<ul style="list-style-type: none"> <li>• Check the engine-oil level.</li> <li>• Remove grass clippings and dirt from under the housing.</li> <li>• Inspect the air-filter elements.</li> <li>• Inspect the mower blades for wear or damage.</li> <li>• Inspect the accelerator for wear or damage.</li> <li>• Check the stopping time of the blade brake. The blade must stop within 3 seconds of releasing the blade-control bar; if it does not, contact an Authorized Service Dealer for repair.</li> <li>• Check for loose or missing fasteners on the engine.</li> <li>• Check for fuel or oil leaks.</li> <li>• Check or clean the recoil starter and the air-intake screen.</li> </ul>
Every 40 hours	<ul style="list-style-type: none"> <li>• Clean the wheels and gears.</li> </ul>
Every 50 hours	<ul style="list-style-type: none"> <li>• Clean the air-filter elements. Clean them more frequently in dusty operating conditions.</li> <li>• Change the engine oil (more frequently in dusty conditions).</li> <li>• Sharpen or replace the blade. Maintain it more frequently if the edge dulls quickly in rough or in sandy conditions.</li> <li>• Remove grass clippings and debris from under the belt cover.</li> <li>• Clean the blade-brake-clutch shield.</li> </ul>
Every 100 hours	<ul style="list-style-type: none"> <li>• Inspect, clean, and adjust the spark plug gap; replace the spark plug if necessary.</li> <li>• Tighten any loose fasteners.</li> <li>• Check or clean the recoil starter and the air-intake screen.</li> </ul>
Every 200 hours	<ul style="list-style-type: none"> <li>• Replace the air-filter elements. Replace them more frequently in dusty operating conditions.</li> <li>• Have an authorized engine servicing dealer check for leaks in the fuel system and/or a deteriorating fuel hose. Replace parts if necessary.</li> </ul>
Every 300 hours	<ul style="list-style-type: none"> <li>• Clean the cylinder and the cylinder-head fins.</li> <li>• Have an authorized engine servicing dealer check and adjust the engine idle speed.</li> <li>• Have an authorized engine servicing dealer clean the combustion chamber.</li> <li>• Have an authorized engine servicing dealer check and adjust the valve clearance.</li> <li>• Have an authorized engine servicing dealer clean and lap the valve seating surface.</li> </ul>

**Important:** Refer to your engine owner's manual for additional maintenance procedures.

## Maintenance Safety

- Disconnect the spark-plug wire from the spark plug before performing any maintenance procedure.
- Wear gloves and eye protection when servicing the machine.
- The blade is sharp; contacting the blade can result in serious personal injury. Wear gloves when servicing the blade. Do not repair or alter the blade(s).
- Never tamper with safety devices. Check their proper operation regularly.
- Tipping the machine may cause the fuel to leak. Fuel is flammable and explosive, and can cause personal injury. Run the engine dry or remove the fuel with a hand pump; never siphon the fuel.
- To ensure optimum performance and continued safety certification of the machine, use only genuine Toro replacement parts and accessories. Replacement parts and accessories made by other manufacturers could be dangerous, and such use could void the product warranty.

# Servicing the Air Filter

**Service Interval:** Before each use or daily—Inspect the air-filter elements.

Every 50 hours—Clean the air-filter elements. Clean them more frequently in dusty operating conditions.

Every 200 hours—Replace the air-filter elements. Replace them more frequently in dusty operating conditions.

**Important:** Do not operate the engine without the air-filter assembly in place; otherwise, extreme engine damage will occur.

1. Shut off the engine and wait for all moving parts to stop.
2. Disconnect the wire from the spark plug.
3. Remove the 2 nuts that secure the cover (Figure 23).
4. Remove the cover.

**Note:** Be careful to prevent dirt and debris from falling into the base of the air filter.

5. Remove the foam and paper elements from the base of the air filter (Figure 23).
6. Remove the foam element from the paper element (Figure 23).

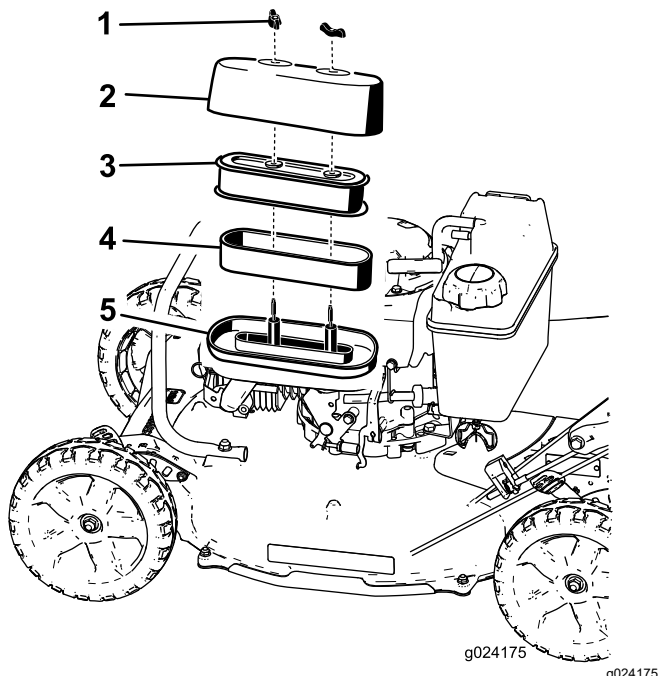

**Figure 23**

- |                  |                 |
|------------------|-----------------|
| 1. Nut (2)       | 4. Foam element |
| 2. Cover         | 5. Base         |
| 3. Paper element |                 |

7. Inspect the foam and paper elements, and replace them if they are damaged or excessively dirty.
8. If the paper element is excessively dirty, replace it.

**Note:** Never try to brush dirt off the paper element; brushing forces the dirt into the fibers.

9. Clean the foam element in warm, soapy water or in a **nonflammable** solvent.

**Note:** Do not use gasoline to clean the foam element because it could create a risk of fire or explosion.

10. Rinse and dry the foam element thoroughly.
11. Dip the foam element in clean engine oil, then squeeze out the excess oil.

**Note:** Excess oil in the foam element restricts the air flow through the element and may reach the paper filter and clog it.

12. Wipe dirt from both the base and the cover of the air filter with a moist rag.

**Note:** Be careful to prevent dirt and debris from entering the air duct leading to the carburetor.

13. Install the air-filter elements and ensure that they are properly in place.
14. Securely install the cover with the 2 nuts that you removed in step 3.

## Changing the Engine Oil

**Service Interval:** After the first 8 hours

Every 50 hours

Run the engine a few minutes before changing the oil to warm it. Warm oil flows better and carries more contaminants.

### Engine Oil Specifications

<b>Engine oil capacity</b>	0.65 L (22 fl oz)
<b>Oil viscosity</b>	SAE 30 or SAE 10W-30 detergent oil
<b>API service classification</b>	SJ or higher

1. Shut off the engine and wait for all moving parts to stop.
2. Disconnect the wire from the spark plug.
3. Drain the fuel from the fuel tank.
4. Place a suitable drain pan under the dipstick/oil drain.
5. Clean around the dipstick.
6. Remove the dipstick by rotating the cap counterclockwise and pulling it out.

7. Tip the machine onto its **right** side (air filter up) to drain the oil into the drain pan.
8. After draining the oil, return the machine to the operating position.
9. Fill the crankcase to the correct level on the dipstick with fresh oil; refer to [Checking the Engine-Oil Level \(page 13\)](#).
10. Insert the dipstick into the filler neck and rotate the cap clockwise until it is tight.
11. Wipe up any spilled oil.
12. Recycle the used oil according to local codes.

## Servicing the Spark Plug

**Service Interval:** Every 100 hours—Inspect, clean, and adjust the spark plug gap; replace the spark plug if necessary.

Use an **NGK BPR5ES** spark plug or equivalent.

1. Shut off the engine and wait for all moving parts to stop.
2. Disconnect the wire from the spark plug.
3. Clean around the spark plug.
4. Remove the spark plug from the cylinder head.

**Important:** Replace a cracked, fouled, or dirty spark plug. Do not clean the electrodes because grit entering the cylinder can damage the engine.

5. Set the gap on the plug to 0.76 mm (0.030 inch); refer to [Figure 24](#).

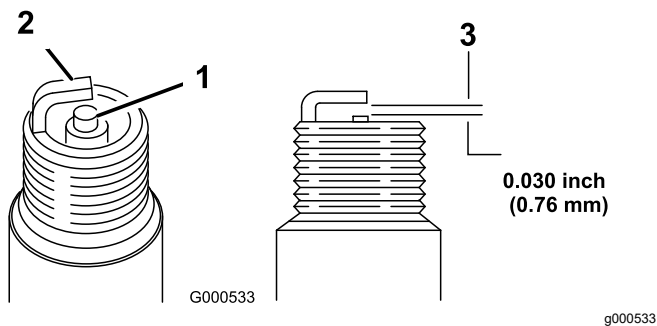

**Figure 24**

1. Center-electrode insulator
2. Side electrode
3. Air gap (not to scale)

6. Carefully install the spark plug by hand (to avoid cross threading) until it is hand tight.
7. Tighten the spark plug to 23 N·m (2.3 kgf-m, 17 ft-lb).

**Important:** A loose spark plug can become very hot and can damage the engine;

**overtightening a spark plug may damage the threads in the cylinder head.**

8. Connect the wire to the spark plug.

## Adjusting the Self-Propel Drive

If the machine is new, does not self-propel, or it tends to creep forward, adjust the drive cable.

1. Move the machine outside and onto a paved surface near a solid wall to safely prevent the machine from moving forward while the engine is running.
2. Position the machine with the front tires against the wall.

**Note:** Ensure that the area is well ventilated and clear of debris that could be thrown by the machine.

3. Shift the transmission to third gear.
4. Start the engine; refer to [Starting the Engine \(page 15\)](#).

5. Pull the self-propel-drive bar to the handle.

**Note:** The wheels should start to turn as the self-propel-drive bar just touches the handle.

6. Shut off the engine.
7. If you must adjust the machine, do the following:
  - If the wheels do not spin when you engage the self-propel-drive bar, the traction belt is too loose. Rotate the wheel-drive-control knob ([Figure 25](#)) clockwise 1 turn and repeat steps 4 through 6.

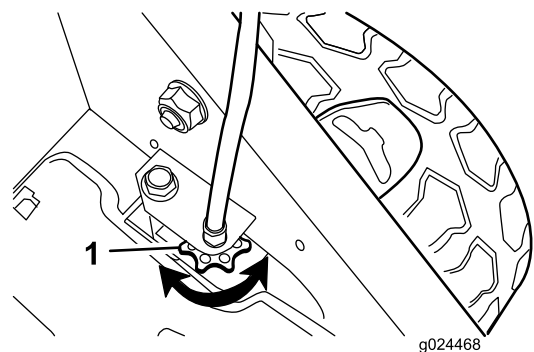

**Figure 25**

1. Wheel-drive-control knob

- If the wheels spin before you fully engage the self-propel-drive bar, the traction belt is too tight. Rotate the wheel-drive-control knob ([Figure 25](#)) counterclockwise 1 turn and repeat steps 4 through 6.

- For a new traction belt, rotate the drive-cable-adjustment knob clockwise 1 additional turn to allow for the normal stretching of the belt during the break-in period.

**Note:** You can skip this step if you are adjusting a used belt.

## Maintaining the Blade

Always mow with a sharp blade. A sharp blade cuts cleanly and without tearing or shredding the grass blades.

- Shut off the engine and wait for all moving parts to stop.
- Disconnect the wire from the spark plug.
- Close the fuel valve by moving the fuel-valve lever to the **left** (Figure 14).
- Drain the fuel from the fuel tank.
- Tip the machine onto its **right** side (air cleaner up) as shown in Figure 26.

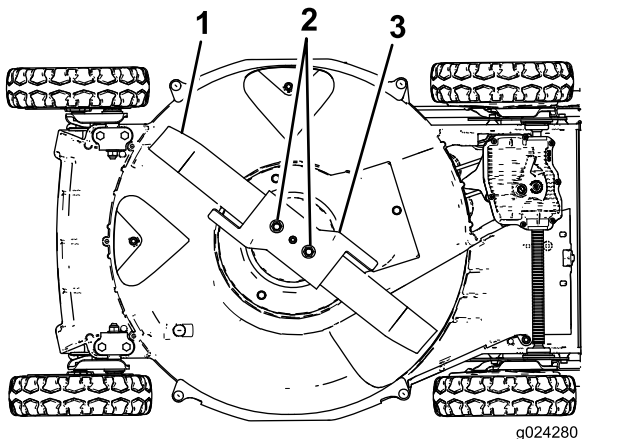

**Figure 26**

- Blade
- Blade nuts
- Accelerator

## Inspecting the Blade

**Service Interval:** Before each use or daily—Inspect the mower blades for wear or damage.

Carefully examine the blade for sharpness and wear, especially where the flat and the curved parts meet (Figure 27A). Because sand and abrasive material can wear away the metal that connects the flat and curved parts of the blade, check the blade before using the machine. If you notice a slot or wear (Figure 27B and Figure 27C), replace the blade; refer to [Removing the Blade \(page 26\)](#).

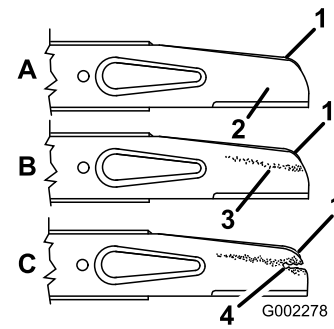

**Figure 27**

- Sail
- Flat part of the blade
- Wear
- Slot formed

**Note:** For the best performance, install a new blade before the mowing season begins. During the year, file down any small nicks to maintain the cutting edge.

### **⚠ DANGER**

**A worn or damaged blade can break, and a piece of the blade could be thrown toward you or bystanders, resulting in serious personal injury or death.**

- Inspect the blade periodically for wear or damage.
- Replace a worn or damaged blade.

## Inspecting the Accelerator

**Service Interval:** Before each use or daily—Inspect the accelerator for wear or damage.

Carefully examine the accelerator for excessive wear (Figure 28). Because sand and abrasive material can wear away the metal (especially in the area shown as item 2 in Figure 28), check the accelerator before using the machine. If you notice that a tab on the accelerator has been worn down to a sharp edge or there is a crack, replace the accelerator; refer to [Removing the Blade \(page 26\)](#).

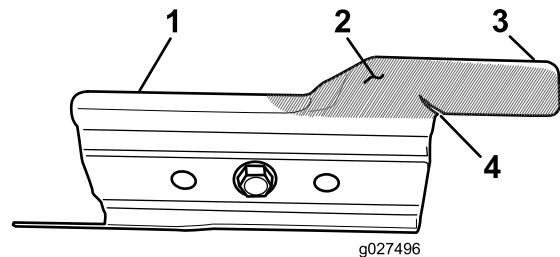

**Figure 28**

- Accelerator
- Wear area
- Tab
- Crack formed

## ⚠ WARNING

A worn or damaged accelerator can break, and a piece of the accelerator could be thrown toward you or bystanders, resulting in serious personal injury or death.

- Inspect the accelerator periodically for wear or damage.
- Replace a worn or damaged accelerator.

## Removing the Blade

1. Grasp the end of the blade using a rag or a thickly padded glove.
2. Remove the blade nuts, the accelerator, and the blade (Figure 27).

## Sharpening the Blade

**Service Interval:** Every 50 hours—Sharpen or replace the blade. Maintain it more frequently if the edge dulls quickly in rough or in sandy conditions.

File the top side of the blade to maintain its original cutting angle (Figure 29A) and inner cutting edge radius (Figure 29B). The blade will remain balanced if you remove the same amount of material from both cutting edges.

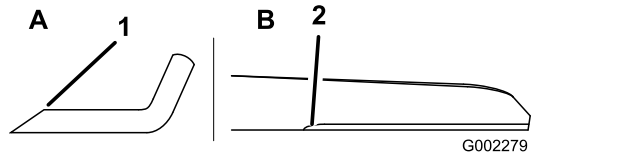

Figure 29

1. Sharpen the blade at this angle only.
2. Maintain the original radius here.

## Balancing the Blade

1. Check the balance of the blade by placing the center hole of the blade over a nail or screwdriver shank clamped horizontally in a vise (Figure 30).

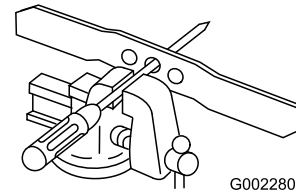

Figure 30

**Note:** You can also check the balance using a commercially manufactured blade balancer.

2. If either end of the blade rotates downward, file that end (not the cutting edge or the end near the cutting edge) until neither end of the blade drops.

## Installing the Blade

1. Install a sharp, balanced Toro blade, the accelerator, and the blade nuts. The sail of the blade must point toward the top of the mower housing for proper installation.

**Note:** Torque the blade nuts to 20 to 37 N·m (15 to 27 ft·lb).

## ⚠ WARNING

Operating the machine without the accelerator in place can cause the blade to flex, bend, or break, resulting in serious injury or death to you or to bystanders.

**Do not operate the machine without the accelerator in place.**

2. Return the machine to the operating position.



# Adjusting the Blade-Brake Cable

The blade-brake cable is adjusted at the factory; you do not need to adjust it unless you are replacing the cable or the blade-brake belt. **If you need to replace the cable, replace both the cable and the belt at the same time.**

1. Shut off the engine and wait for all moving parts to stop.
2. Disconnect the wire from the spark plug.
3. Install a new blade-brake belt and assemble the machine except for the 2 belt covers on the top of the mower housing.
4. Install the new blade-brake cable, but do not tighten the cable clamp on the top of the mower housing (Figure 31).

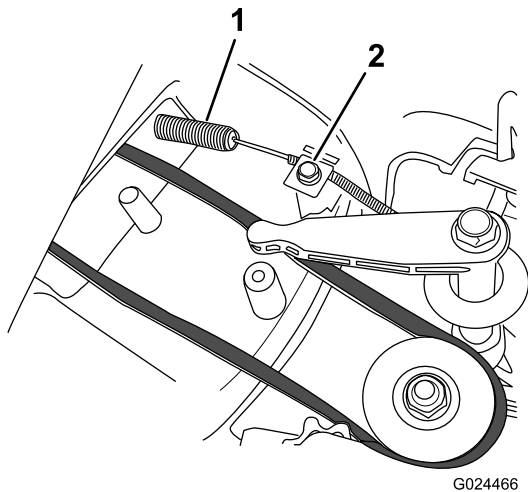

Figure 31

1. Spring
2. Cable clamp and screw

5. Loosen the cable-clamp screw (Figure 31).
6. Pull the cable jacket to remove slack (Figure 32).

**Note:** Do not put tension on the spring.

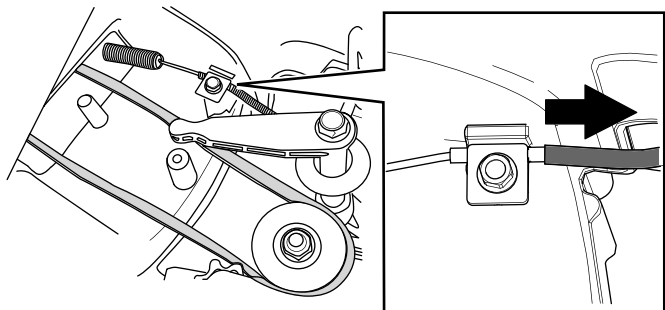

Figure 32

7. Mark the brake cable (Figure 33), then adjust the jacket until there is approximately 8 mm (5/16 inch) of slack (Figure 34).

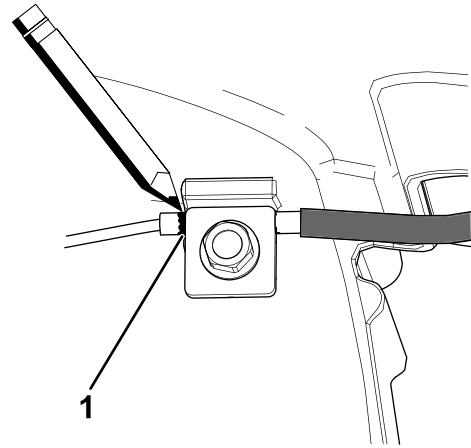

Figure 33

1. Mark the cable here

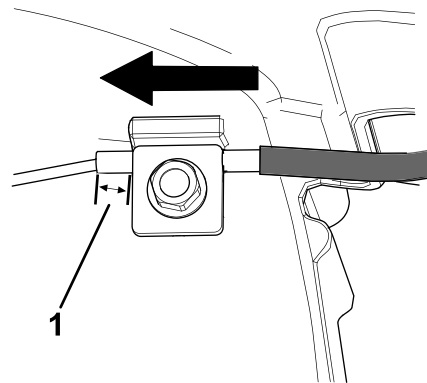

Figure 34

1. Slack— 8 mm (5/16 inch)

8. Torque the cable-clamp screw to 11 to 14 N·m (99 to 121 in-lb) to lock the adjustment in place.
9. Install the belt cover with the bolts that you removed to take off the 2 belt covers.
10. Connect the wire to the spark plug.

# Cleaning under the Belt Cover

**Service Interval:** Every 50 hours—Remove grass clippings and debris from under the belt cover.

1. Shut off the engine and wait for all moving parts to stop.
2. Disconnect the wire from the spark plug.
3. Remove the belt cover (Figure 35) from the mower housing.

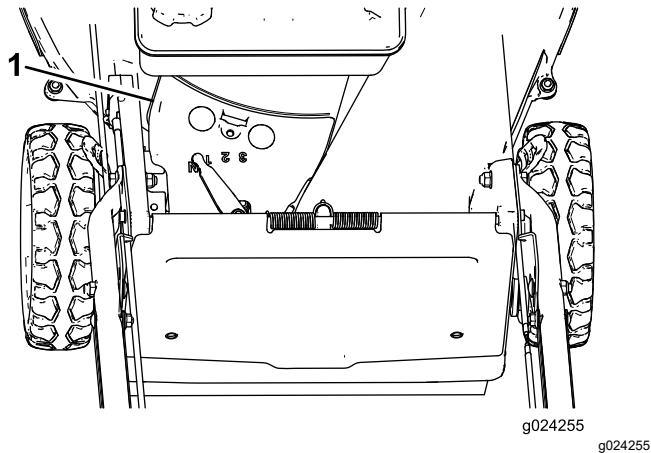

Figure 35

1. Belt cover

- 
4. Lift off the cover and brush out all the debris around the belt area.
  5. Install the belt cover.
  6. Connect the wire to the spark plug.

# Cleaning the Blade-Brake-Clutch Shield

**Service Interval:** Every 50 hours

Clean the blade-brake-clutch shield to ensure the best performance and to prevent parts from degrading. Clean the blade-brake-clutch shield when you sharpen the blade, because you need to remove the blade in order to remove the blade-brake-clutch shield.

1. Shut off the engine and wait for all moving parts to stop.
2. Disconnect the wire from the spark plug.
3. Close the fuel valve by moving the fuel-valve lever to the **left** (Figure 14).
4. Drain the fuel from the fuel tank.
5. Tip the machine onto its **right** side (air filter up).

## ▲ WARNING

Tipping the machine may cause the fuel to leak from the carburetor or the fuel tank. Fuel is extremely flammable, highly explosive, and, under certain conditions, can cause personal injury or property damage.

**Avoid fuel spills by emptying the fuel tank as directed; never siphon.**

6. Remove the 2 blade nuts, the accelerator, and the blade (Figure 36).

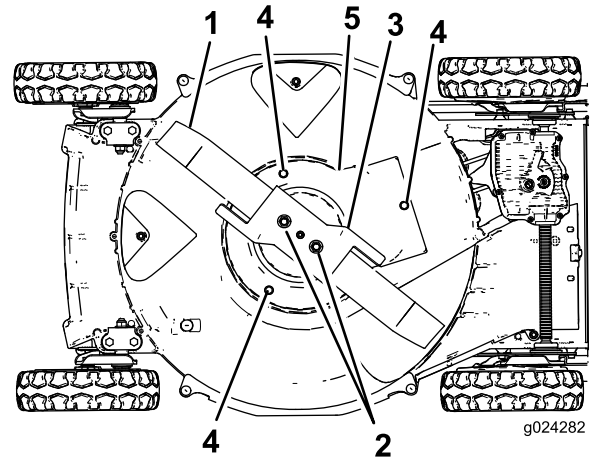

Figure 36

1. Blade
2. Blade nuts
3. Accelerator
4. Screw
5. Blade-brake-clutch shield

- 
7. Remove the screws that secure the blade-brake-clutch shield to the mower housing (Figure 36).
  8. Remove the blade-brake-clutch shield and brush or blow all the debris from under the shield and around the blade-brake-clutch.
  9. Tighten the screws to secure the blade-brake-clutch shield to the housing.
  10. Install the blade, the accelerator, and the 2 blade nuts.
  11. Return the machine to the operating position.



# Cleaning the Wheels

**Service Interval:** Every 40 hours

1. Remove the rear wheels and clean any debris from the wheel-gear area.

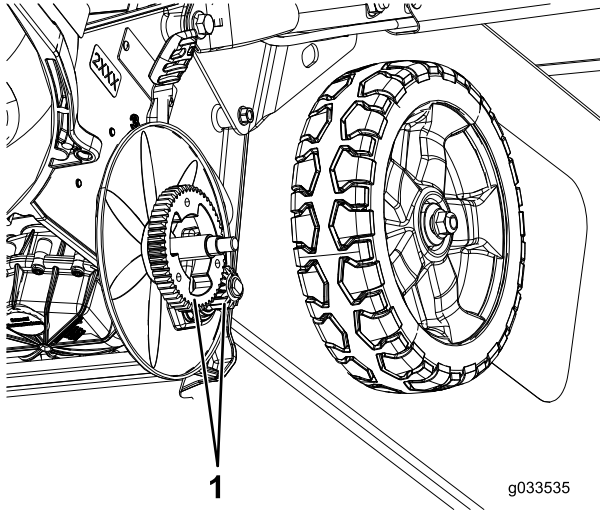

**Figure 37**

1. Gears
- 

2. After cleaning, apply a small amount of anti-seize compound to the gears.

**Note:** If you operate the machine in extreme conditions, cleaning the wheels more frequently than recommended will increase gear life.

**Note:** To prevent damage to the bearing seals, do not use a high-pressure water spray on the bearings.

# Storage

To prepare the machine for off-season storage, perform the recommended maintenance procedures; refer to [Maintenance \(page 22\)](#).

Store the machine in a cool, clean, dry place. Cover the machine to keep it clean and protected.

## Preparing the Fuel System

Empty the fuel from the fuel tank when mowing for the last time before storing the machine.

1. Run the engine until it shuts off from running out of fuel.
2. Choke the engine and start it again.
3. Allow the engine to run until it shuts off. When you can no longer start the engine, it is sufficiently dry.

## Preparing the Engine

1. While the engine is still warm, change the oil in the crankcase; refer to [Changing the Engine Oil \(page 23\)](#).
2. Remove the spark plug.
3. Using an oil can, add about 30 ml (1 fl oz) of engine oil to the engine crankcase through the spark-plug hole.
4. Slowly rotate the engine several times by pulling the recoil-start handle to distribute the oil throughout the engine crankcase.
5. Install the spark plug but **do not** connect the wire to the spark plug.

## General Information

1. Clean under the machine; refer to [Cleaning under the Machine \(page 21\)](#).
2. Clean any dirt and chaff from the cylinder, cylinder head fins, and blower housing.
3. Remove grass clippings, dirt, and grime from the external parts of the engine, the shrouding, and the top of the mower housing.
4. Check the condition of the blade; refer to [Inspecting the Blade \(page 25\)](#).
5. Check the condition of the accelerator; refer to [Inspecting the Accelerator \(page 25\)](#).
6. Service the air filter; refer to [Servicing the Air Filter \(page 23\)](#).
7. Tighten all nuts, bolts, and screws.

8. Touch up all rusted or chipped paint surfaces with paint available from an Authorized Service Dealer.

## Removing the Machine from Storage

1. Check and tighten all fasteners.
2. Remove the spark plug and spin the engine rapidly using the starter to blow out the excess oil from the cylinder.
3. Clean the spark plug or replace it if it is cracked, broken, or if the electrodes are worn.
4. Install the spark plug; refer to [Servicing the Spark Plug \(page 24\)](#).
5. Perform any needed maintenance procedures; refer to [Maintenance \(page 22\)](#).
6. Fill the fuel in the fuel tank with fresh fuel.
7. Check the engine-oil level.
8. Connect the wire to the spark plug.

# Troubleshooting

Problem	Possible Cause	Corrective Action
The engine does not start.	<ol style="list-style-type: none"> <li>1. The fuel tank is empty or the fuel system contains stale fuel.</li> <li>2. The throttle lever is not in the CHOKE position.</li> <li>3. The wire is not connected to the spark plug.</li> <li>4. The spark plug is pitted, fouled, or the gap is incorrect.</li> </ol>	<ol style="list-style-type: none"> <li>1. Drain and/or fill the fuel tank with fresh fuel. If the problem persists, contact an Authorized Service Dealer.</li> <li>2. Move the throttle lever to the CHOKE position.</li> <li>3. Connect the wire to the spark plug.</li> <li>4. Check the spark plug and adjust the gap if necessary. Replace the spark plug if it is pitted, fouled, or cracked.</li> </ol>
The engine starts hard or loses power.	<ol style="list-style-type: none"> <li>1. The fuel tank contains stale fuel.</li> <li>2. The air-filter element is dirty and is restricting the air flow.</li> <li>3. The underside of the machine contains clippings and debris.</li> <li>4. The spark plug is pitted, fouled, or the gap is incorrect.</li> <li>5. The engine-oil level is low or the oil is dirty.</li> </ol>	<ol style="list-style-type: none"> <li>1. Drain and fill the fuel tank with fresh fuel.</li> <li>2. Clean the air-filter pre-cleaner and/or replace the paper air filter.</li> <li>3. Clean the underside of the machine.</li> <li>4. Check the spark plug and adjust the gap if necessary. Replace the spark plug if it is pitted, fouled, or cracked.</li> <li>5. Check the engine oil. Change the oil if it is dirty or add oil if it is low.</li> </ol>
The engine runs rough.	<ol style="list-style-type: none"> <li>1. The wire is not connected to the spark plug.</li> <li>2. The spark plug is pitted, fouled, or the gap is incorrect.</li> <li>3. The throttle lever is not in the FAST position.</li> <li>4. The air-filter element is dirty and is restricting the air flow.</li> </ol>	<ol style="list-style-type: none"> <li>1. Connect the wire to the spark plug.</li> <li>2. Check the spark plug and adjust the gap if necessary. Replace the spark plug if it is pitted, fouled, or cracked.</li> <li>3. Move the throttle lever to the FAST position.</li> <li>4. Clean the air-filter pre-cleaner and/or replace the paper air filter.</li> </ol>
The machine or engine vibrates excessively.	<ol style="list-style-type: none"> <li>1. The blade is bent or is out of balance.</li> <li>2. The blade mounting nuts are loose.</li> <li>3. The underside of the machine contains clippings and debris.</li> <li>4. The engine mounting bolts are loose.</li> </ol>	<ol style="list-style-type: none"> <li>1. Balance the blade. If the blade is bent, replace it.</li> <li>2. Tighten the blade mounting nuts.</li> <li>3. Clean the underside of the machine.</li> <li>4. Tighten the engine mounting bolts.</li> </ol>
The is an uneven cutting pattern.	<ol style="list-style-type: none"> <li>1. All 4 wheels are not at the same height.</li> <li>2. The blade is dull.</li> <li>3. You are mowing in the same pattern repeatedly.</li> <li>4. The underside of the machine contains clippings and debris.</li> </ol>	<ol style="list-style-type: none"> <li>1. Place all 4 wheels at the same height.</li> <li>2. Sharpen and balance the blade.</li> <li>3. Change the mowing pattern.</li> <li>4. Clean the underside of the machine.</li> </ol>
The discharge chute plugs up.	<ol style="list-style-type: none"> <li>1. The throttle lever is not in the FAST position.</li> <li>2. The cutting height is too low.</li> <li>3. You are mowing too fast.</li> <li>4. The grass is wet.</li> <li>5. The underside of the machine contains clippings and debris.</li> </ol>	<ol style="list-style-type: none"> <li>1. Move the throttle lever to the FAST position.</li> <li>2. Raise the cutting height.</li> <li>3. Slow down.</li> <li>4. Allow the grass to dry before mowing.</li> <li>5. Clean the underside of the machine.</li> </ol>



**Count on it.**