



**Count on it.**

**Operator's Manual**

# Flex-Force Power System™ 14in or 16in 60V MAX String Trimmer

Model No. 51830—Serial No. 319000001 and Up

Model No. 51830T—Serial No. 319000001 and Up

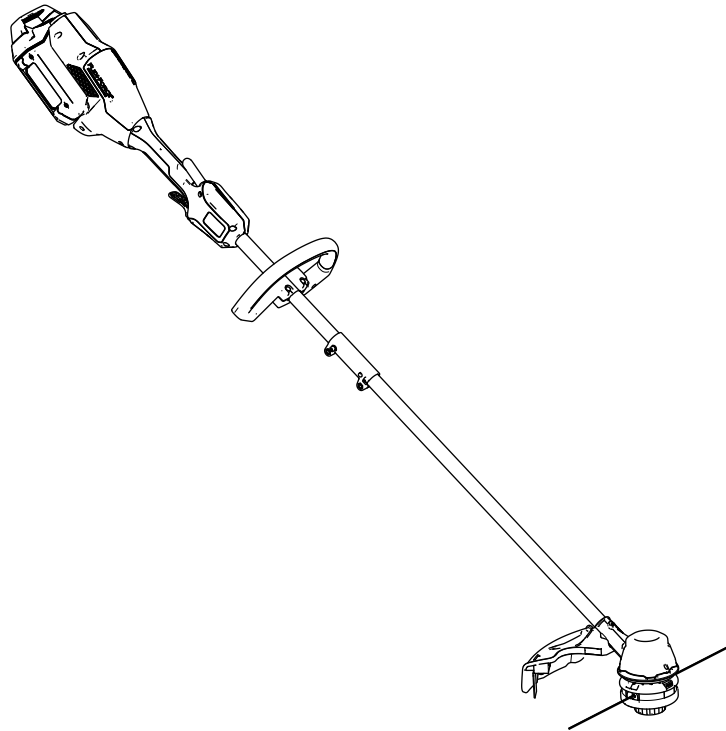



For assistance, please see [www.Toro.com/support](http://www.Toro.com/support) for instructional videos or contact 1-888-384-9939 before returning this product.

**⚠ WARNING**

**CALIFORNIA  
Proposition 65 Warning**

The power cord on this product contains lead, a chemical known to the State of California to cause birth defects or other reproductive harm. Wash hands after handling.

Use of this product may cause exposure to chemicals known to the State of California to cause cancer, birth defects, or other reproductive harm.

numbers of your product ready. [Figure 1](#) identifies the location of the model and serial numbers on the product. Write the numbers in the space provided.

**Important:** With your mobile device, you can scan the QR code on the serial number decal (if equipped) to access warranty, parts, and other product information.

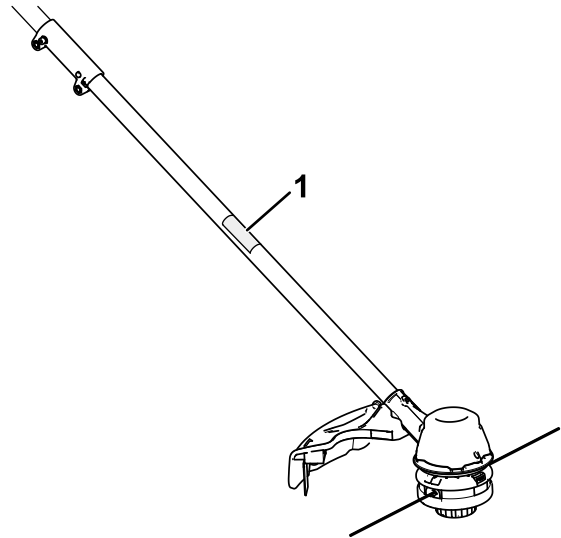

**Figure 1**

g360642

1. Model and serial number location

Model No.	_____
Serial No.	_____

This manual identifies potential hazards and has safety messages identified by the safety-alert symbol ([Figure 2](#)), which signals a hazard that may cause serious injury or death if you do not follow the recommended precautions.



**Figure 2**

Safety-alert symbol

g000502

This manual uses 2 words to highlight information. **Important** calls attention to special mechanical information and **Note** emphasizes general information worthy of special attention.

# Introduction

This trimmer is intended to be used by residential homeowners to trim grass as needed outdoors. It is designed to use Toro Flex-Force lithium-ion battery pack Models 88625 (provided with Model 51830), Model 88620, Model 88640, Model 88650, Model 88660, or Model 88675. These battery packs are designed to be charged only by battery charger Models 88602 (provided with Model 51830), 88605, or 88610. Using this product for purposes other than its intended use could prove dangerous to you and bystanders.

**Model 51830T does not include a battery or a charger.**

Read this information carefully to learn how to operate and maintain your product properly and to avoid injury and product damage. You are responsible for operating the product properly and safely.

Visit [www.Toro.com](http://www.Toro.com) for product safety and operation training materials, accessory information, help finding a dealer, or to register your product.

Whenever you need service, genuine the manufacturer parts, or additional information, contact an Authorized Service Dealer or the manufacturer Customer Service and have the model and serial

# Safety

**WARNING**—When using electric gardening appliances, always read and follow basic safety warnings and instructions to reduce the risk of fire, electric shock, and personal injury, including the following:

## IMPORTANT SAFETY INSTRUCTIONS

### I. Training

1. The operator of the appliance is responsible for any accidents or hazards occurring to others or their property.
2. Do not allow children to use or play with the appliance, battery pack, or the battery charger; local regulations may restrict the age of the operator.
3. Do not allow children or untrained people to operate or service this device. Allow only people who are responsible, trained, familiar with the instructions, and physically capable to operate or service the device.
4. Before using the appliance, battery pack, and battery charger, read all the instructions and cautionary markings on these products.
5. Become familiar with the controls and proper use of the appliance, battery pack, and battery charger.

### II. Preparation

1. Keep bystanders and children away from the operating area.
2. Use only the battery pack specified by Toro. Using other accessories and attachments may increase the risk of injury and fire.
3. Plugging the battery charger into an outlet that is not 120 V can cause a fire or electric shock. Do not plug the battery charger into an outlet other than 120 V. For a different style of connection, use an attachment plug adapter of the proper configuration for the power outlet if needed.
4. Do not use a damaged or modified battery pack or battery charger, which may exhibit unpredictable behavior that results in fire, explosion, or risk of injury.
5. If the supply cord to the battery charger is damaged, contact an Authorized Service Dealer to replace it.
6. Do not use non-rechargeable batteries.
7. Charge the battery pack with only the battery charger specified by Toro. A charger suitable for

1 type of battery pack may create a risk of fire when used with another battery pack.

8. Charge the battery pack in a well-ventilated area only.
9. Do not expose a battery pack or battery charger to fire or to temperatures higher than 68°C (154°F).
10. Follow all charging instructions and do not charge the battery pack outside of the temperature range specified in the instructions. Otherwise, you may damage the battery pack and increase the risk of fire.
11. Do not operate the appliance without all guards and other safety protective devices in place and functioning properly on the appliance.
12. Dress properly—Wear appropriate clothing, including eye protection; long pants; substantial, slip-resistant footwear; rubber gloves; and hearing protection. Tie back long hair and do not wear loose clothing or loose jewelry that can get caught in moving parts. Wear a dust mask in dusty operating conditions.

### III. Operation

1. Avoid dangerous environments—Do not use the appliance in rain or in damp or wet locations.
2. Use the proper appliance for your application—Using the appliance for purposes other than its intended use could prove dangerous to you and bystanders.
3. Prevent unintentional starting—Ensure that the switch is in the OFF position before connecting to the battery pack and handling the appliance. Do not carry the appliance with your finger on the switch or energize the appliance with the switch in the ON position.
4. Operate the appliance only in daylight or good artificial light.
5. Remove the battery pack from the appliance before adjusting it or changing accessories.
6. Keep your hands and feet away from the cutting area and all moving parts.
7. Stop the appliance, remove the battery pack from the appliance, and wait for all movement to stop before adjusting, servicing, cleaning, or storing the appliance.
8. Remove the battery pack from the appliance whenever you leave it unattended.
9. Do not force the appliance—Allow the appliance to do the job better and safer at the rate for which it was designed.
10. Do not overreach—Keep proper footing and balance at all times, especially on slopes. Walk, never run with the appliance.

11. Stay alert—Watch what you are doing and use common sense when operating the appliance. Do not use the appliance while ill, tired, or under the influence of alcohol or drugs.
12. Ensure that the ventilation openings are kept clear of debris.
13. Under abusive conditions, the battery pack may eject liquid; avoid contact. If you accidentally come into contact with the liquid, flush with water. If the liquid contacts your eyes, seek medical help. Liquid ejected from the battery pack may cause irritation or burns.
14. CAUTION—A mistreated battery pack may present a risk of fire or chemical burn. Do not disassemble the battery pack. Do not heat the battery pack above 68°C (154°F) or incinerate it. Replace the battery pack with a genuine Toro battery pack only; using another type of battery pack may cause a fire or explosion. Keep battery packs out of the reach of children and in the original packaging until you are ready to use them.

#### **IV. Maintenance and Storage**

1. Maintain the appliance with care—Keep it clean and in good repair for best performance and to reduce the risk of injury. Follow the instructions for lubricating and changing accessories. Keep handles dry, clean, and free from oil and grease.
2. When the battery pack is not in use, keep it away from metal objects such as paper clips, coins, keys, nails, and screws that can make a connection from 1 terminal to another. Shorting the battery terminals may cause burns or a fire.
3. Keep your hands and feet away from moving parts.
4. Stop the appliance, remove the battery pack from the appliance, and wait for all movement to stop before adjusting, servicing, cleaning, or storing the appliance.
5. Check the appliance for damaged parts—If there are damaged guards or other parts, determine whether it will operate properly. Check for misaligned and binding moving parts, broken parts, mounting, and any other condition that may affect its operation. Unless indicated in the instructions, have an Authorized Service Dealer repair or replace a damaged guard or part.
6. Do not replace the existing non-metallic cutting means on the appliance with a metallic cutting means.
7. Do not attempt to service or repair the appliance, battery pack, or battery charger except as indicated in the instructions. Have an Authorized Service Dealer perform service using identical

replacement parts to ensure that the product is safely maintained.

8. Store an idle appliance indoors in a place that is dry, secure, and out of the reach of children.
9. Do not dispose of the battery in a fire. The cell may explode. Check with local codes for possible special disposal instructions.

## **SAVE THESE INSTRUCTIONS**

# Safety and Instructional Decals



Safety decals and instructions are easily visible to the operator and are located near any area of potential danger. Replace any decal that is damaged or missing.



137-9454

1. Read the *Operator's Manual*.
2. Call2Recycle® battery recycling program
3. Keep away from open fire or flames.
4. Do not expose to rain.

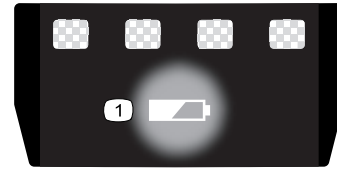

137-9461

decal137-9461

1. Battery charge status



137-9462

decal137-9462



137-9463

decal137-9463

1. The battery pack is charging.
2. The battery pack is fully charged.
3. The battery pack is over or under the appropriate temperature range.
4. Battery pack charging fault



decal139-5210

**139-5210**

1. Warning—read the *Operator's Manual*; stay away from moving parts; keep all guards in place; wear eye protection; do not operate in wet conditions.

0.095" (2.4mm) diameter twisted nylon line / fil en nylon torsadée de 2,4 mm (0.095") de diamètre  
 0.08" (2.0mm) diameter nylon line / fil en nylon de 2,0 mm (0.08") de diamètre

**60V MAX\* DC**

\*Battery manufacturer rating = 60V maximum & 54V nominal.  
 Actual voltage varies with load.

\*Tension indiquée par le fabricant de la batterie = 60 V max.,  
 54 V nominale. La tension réelle varie en fonction de la charge.

Country of Origin: PRC / Pays d'origine : PRC

THE TORO COMPANY  
 8111 Lyndale Avenue South  
 Bloomington, MN 55420-1196 USA  
 PATENT: www.ttcopats.com  
 CAN ICES-3(B)/NMB-3(B)

Model: **51830**  
 Modèle:

Serial Number:  
 Numéro de série:

Date Code:  
 Code de date:

Intertek  
 5013579

Conforms to UL STD 82  
 Certified to CSA STD C22.2 #147

decal139-5212

**139-5212**

**WARNING** TO REDUCE THE RISK OF INJURY, USER MUST READ INSTRUCTION MANUAL.  
 To reduce risk of electric shock, do not expose unit to water or operate unit on wet ground. Risk of eye injury.  
 Use safety glasses or similar eye protection. To reduce the risk of injury to persons, do not operate without guards  
 in place. To reduce risk of injury to persons, remove battery pack when not in use. For use with TORO FlexForce battery model 88625, 88660 & 88675.  
 For use with TORO FlexForce charger model 88602. Use 0.095" (2.4mm) diameter twisted nylon line or 0.08" (2.0mm) diameter nylon line only.

**WARNING** Cancer and Reproductive Harm - www.P65Warnings.ca.gov.  
 For more information, please visit www.ttcoCAProp65.com

**AVERTISSEMENT** POUR RÉDUIRE LES RISQUES DE BLESSURE, L'UTILISATEUR DOIT LIRE ET COMPRENDRE LE MODE D'EMPLOI.  
 Pour réduire les risques d'électrocution, évitez tout contact de la machine avec l'eau et ne l'utilisez pas sur sol mouillé. Risque de blessure oculaire, utilisez des lunettes de sécurité ou autre protection oculaire appropriée.  
 Pour réduire les risques de blessures corporelles, n'utilisez pas la machine si les dispositifs de protection ne sont pas en place. Pour réduire les risques de  
 blessures corporelles, retirez la batterie quand vous ne l'utilisez pas. À utiliser avec la batterie TORO FlexForce, modèles 88625, 88660 & 88675. À utiliser avec le  
 chargeur TORO FlexForce, modèle 88602. Utilisez uniquement du fil en nylon torsadé de 2,4 mm de diamètre ou fil en nylon de 2,0 mm (0,08") de diamètre.

**AVERTISSEMENT** Cancer et Troubles de l'appareil reproducteur - www.P65Warnings.ca.gov.  
 Pour plus d'informations, veuillez visiter www.ttcoCAProp65.com

decal139-5214

**139-5214**

# Setup

## Loose Parts

Use the chart below to verify that all parts have been shipped.

Procedure	Description	Qty.	Use
<b>1</b>	Screws (not included)	2	Mount the battery charger (optional).
<b>2</b>	Allen wrench	1	Unfold the handle.
<b>3</b>	Auxiliary handle assembly	1	Install the auxiliary handle.
<b>4</b>	Guard	1	Install the guard.

**Important:** The battery pack is not fully charged when you purchase it. Before using the tool for the first time, refer to [Charging the Battery Pack](#) (page 13).



## Mounting the Battery Charger (Optional)

Parts needed for this procedure:

2	Screws (not included)
---	-----------------------

## Procedure

If desired, mount the battery charger securely on a wall using the wall-mount key holes on the back of the charger.

Mount it indoors (such as a garage or other dry place), near a power outlet, and out of the reach of children.

Refer to [Figure 3](#) for assistance in mounting the charger.

Slide the charger over the appropriately positioned hardware to secure the charger in place (hardware not included).

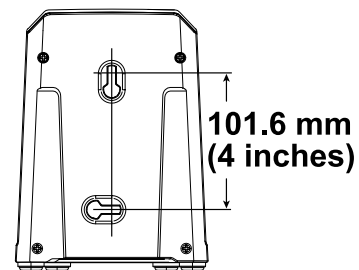

Figure 3

g290534

# 2

## Unfolding the Handle

Parts needed for this procedure:

1	Allen wrench
---	--------------

### Procedure

1. Unfold the handle (A of [Figure 4](#)).
2. Align the locking button on the lower shaft with the slotted hole on the upper shaft and slide the 2 shafts together (B and C of [Figure 4](#)).  
**Note:** The locking button clicks into the slotted hole when the shafts are secured (D of [Figure 4](#)).
3. Using the provided Allen wrench, tighten the screw on the shaft connector until it is secure (E of [Figure 4](#)).

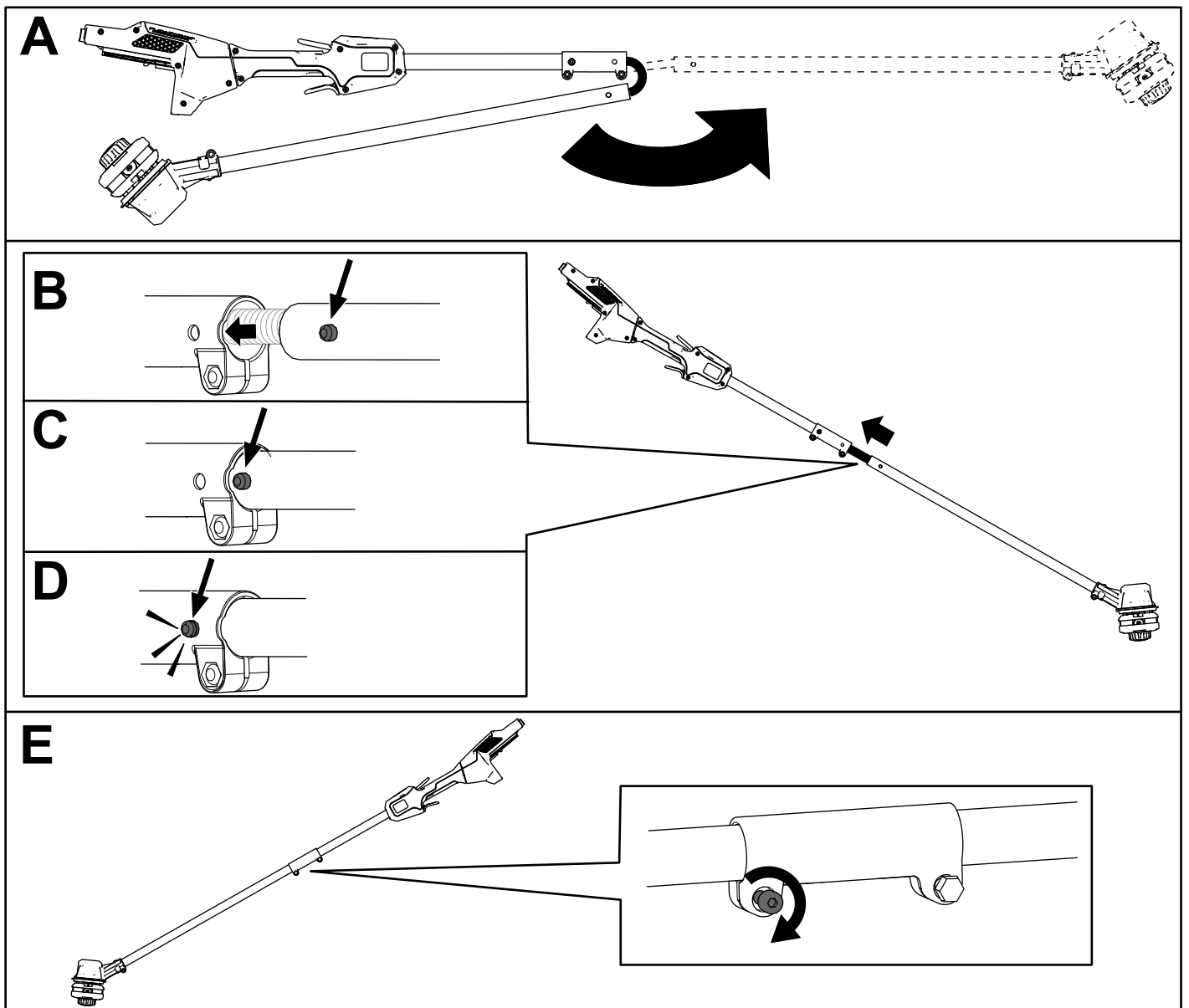

Figure 4

g280969



# 3

## Installing the Auxiliary Handle

Parts needed for this procedure:

1	Auxiliary handle assembly
---	---------------------------

### Procedure

1. Separate the auxiliary handle from the handle plate by removing the 4 socket head screws using the provided Allen wrench (A of [Figure 5](#)).
2. Line up the auxiliary handle with auxiliary handle plate on the trimmer handle (B of [Figure 5](#)).
3. Secure the auxiliary handle to the handle plate with the 4 socket head screws previously removed (C of [Figure 5](#)).

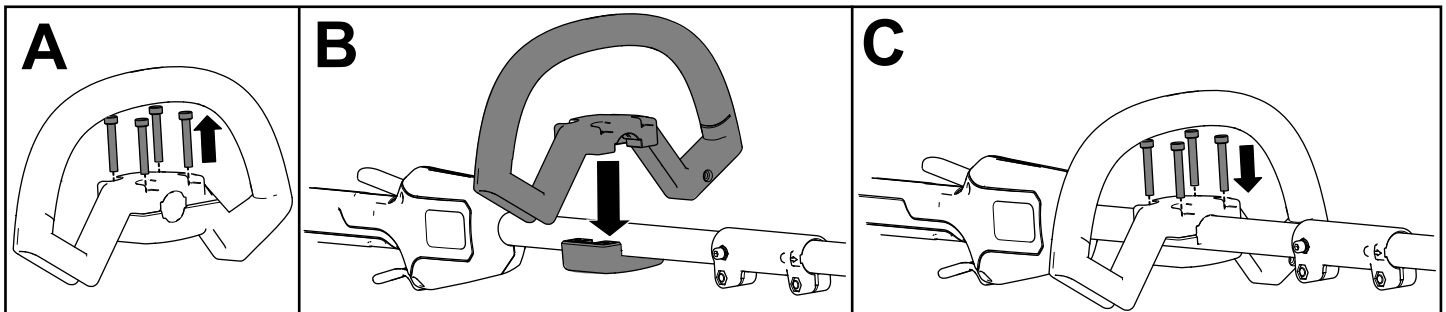

Figure 5

g273280

# 4

## Installing the Guard

Parts needed for this procedure:

1	Guard
---	-------

### Procedure

1. Using the provided Allen wrench, remove the 2 socket head screws, 2 washers, and 2 spacers from the trimmer base (A of [Figure 6](#)).
2. Align the guard onto the trimmer base (B of [Figure 6](#)).
3. Secure the guard onto the base of the trimmer with the 2 socket head screws, 2 washers, and 2 spacers previously removed (C of [Figure 5](#)).

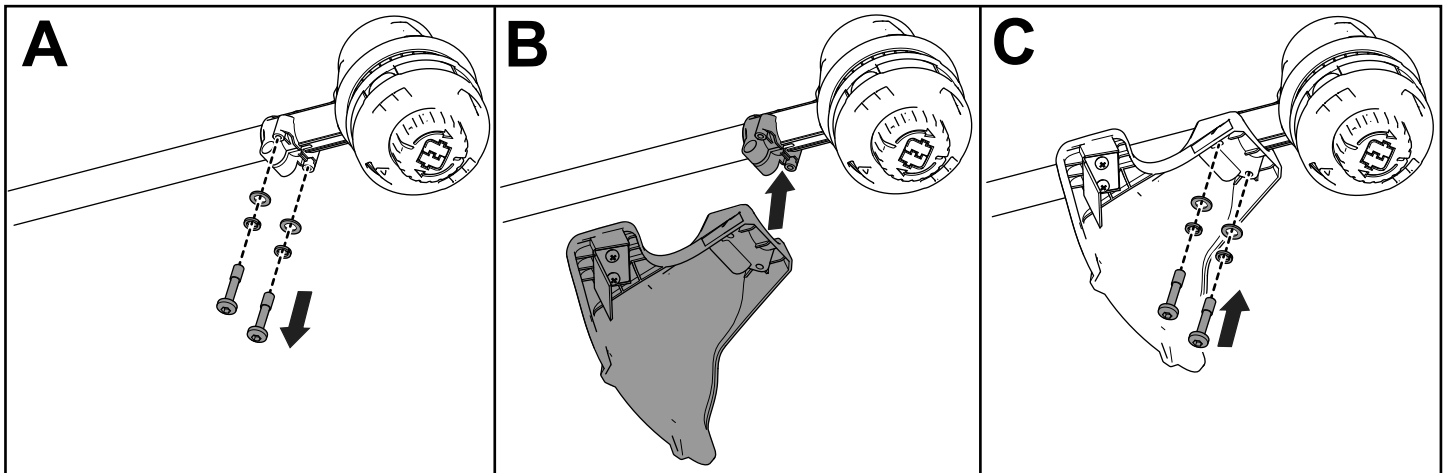
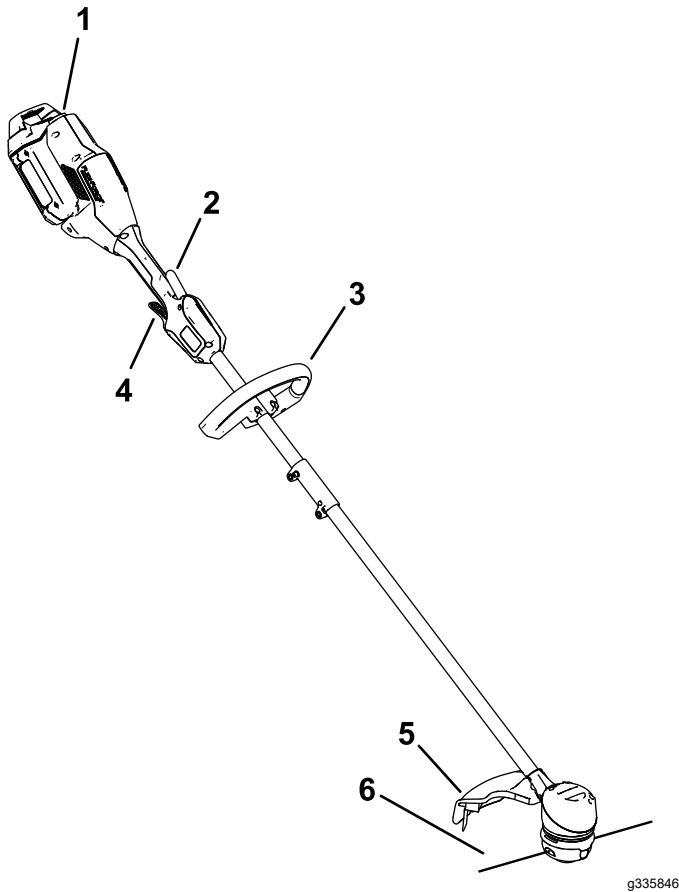

Figure 6

g273281

# Product Overview



**Figure 7**

- 1. Battery latch
- 2. Lockout trigger
- 3. Auxiliary handle
- 4. Run trigger
- 5. Guard
- 6. String

g335846

# Specifications

<b>Model</b>	51830/T
<b>Rated Voltage</b>	60V DC maximum, 54 VDC nominal usage
<b>Charger Type</b>	88602 (included with 51830), 88605, or 88610
<b>Battery Type</b>	88625 (included with 51830), 88620, 88640, 88650, 88660, or 88675

## Appropriate Temperature Ranges

Charge/store the battery pack at	5°C (41°F) to 40°C (104°F)*
Use the battery pack at	-30°C (-22°F) to 49°C (120°F)
Use the trimmer at	0°C (32°F) to 49°C (120°F)
Store the trimmer at	0°C (32°F) to 49°C (120°F)*

\*Charging time will increase if you do not charge the battery within this range.

Store the tool, battery pack, and battery charger in an enclosed clean, dry area.

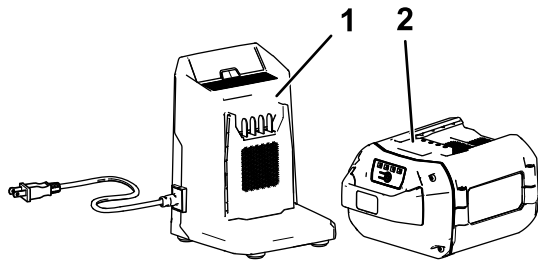

**Figure 8**

- 1. Battery charger Model 88602 (included with Model 51830)
- 2. Battery pack Model 88625 (included with Model 518310)

g355813

# Operation

## Starting the Trimmer

1. Make sure that the vents on the trimmer are clear of any dust and debris.

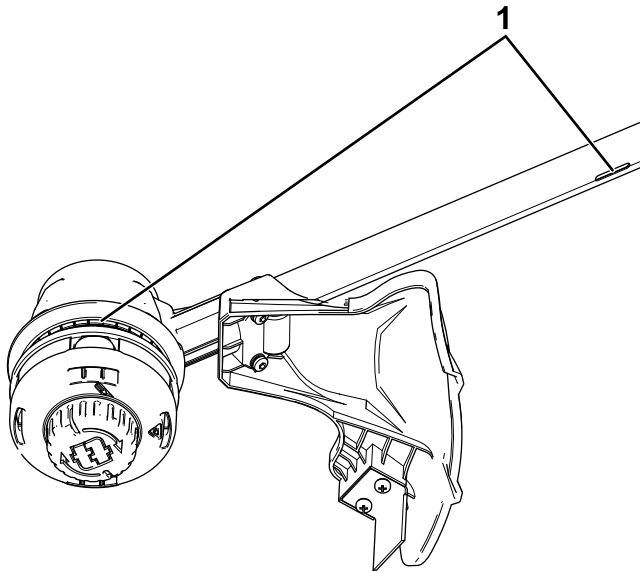

Figure 9

g268141

1. Trimmer venting areas

2. Align the cavity in the battery pack with the tongue on the handle housing (Figure 10).
3. Push the battery pack into the handle until the battery locks into the latch (Figure 10).

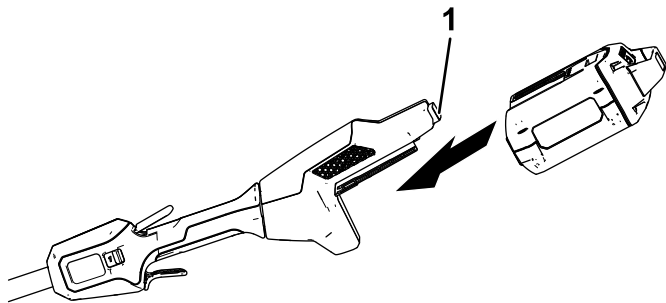

Figure 10

g268418

1. Battery latch

4. To start the trimmer, squeeze the lockout trigger, then squeeze the run trigger (Figure 11).

**Note:** Slide the variable-speed switch to change the speed of the trimmer.

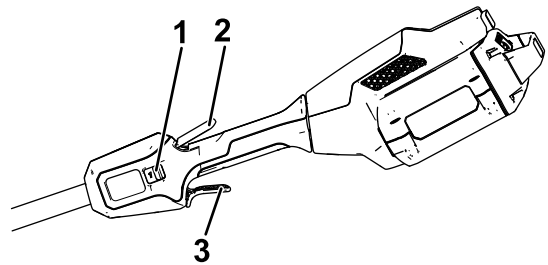

Figure 11

g268420

1. Variable-speed switch
2. Lockout trigger
3. Run trigger

## Shutting Off the Trimmer

To shut off the trimmer, release both triggers.

Whenever you are not using the trimmer or are transporting the trimmer to or from the work area, remove the battery pack.

## Removing the Battery Pack from the Trimmer

Press the battery latch on the machine to release the battery pack and slide the battery pack out of the machine (Figure 12).

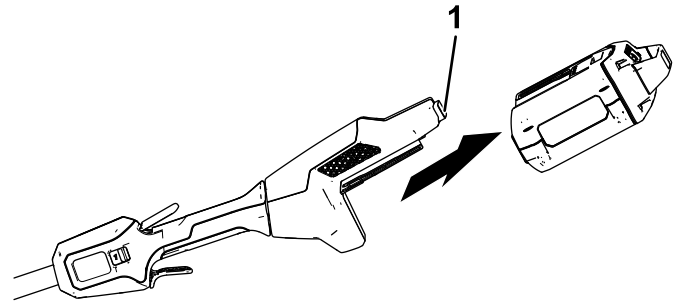

Figure 12

g268419

1. Battery latch

# Charging the Battery Pack

**Important:** The battery pack is not fully charged when you purchase it. Before using the tool for the first time, place the battery pack in the charger and charge it until the LED display indicates the battery pack is fully charged. Read all safety precautions.

**Important:** Charge the battery pack only in temperatures that are within the appropriate range; refer to [Specifications \(page 11\)](#).

**Note:** At any time, press the battery-charge-indicator button on the battery pack to display the current charge (LED indicators).

1. Make sure that the vents on the battery and battery charger are clear of any dust and debris.

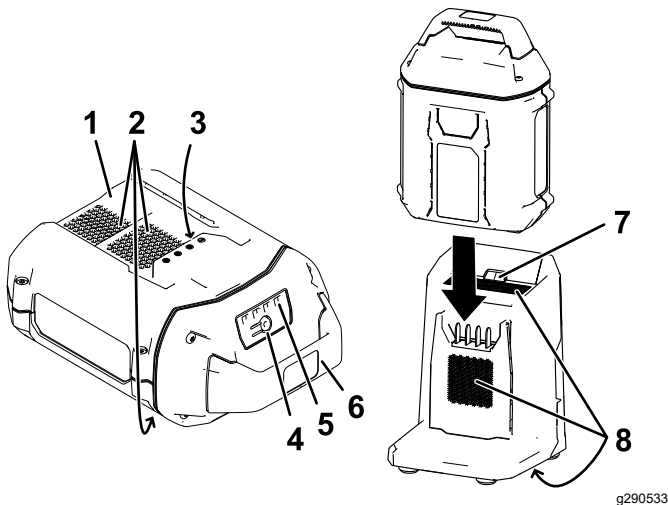

**Figure 13**

- |                                    |                                    |
|------------------------------------|------------------------------------|
| 1. Battery pack cavity             | 5. LED indicators (current charge) |
| 2. Battery pack venting areas      | 6. Handle                          |
| 3. Battery pack terminals          | 7. Charger LED indicator light     |
| 4. Battery-charge-indicator button | 8. Charger venting areas           |
2. Line up the cavity in the battery pack ([Figure 13](#)) with the tongue on the charger.
  3. Slide the battery pack into the charger until it is fully seated ([Figure 13](#)).
  4. To remove the battery pack, slide the battery backward out of the charger.
  5. Refer to the following table to interpret the LED indicator light on the battery charger.

Indicator light	Indicates
Off	No battery pack inserted
Green blinking	Battery pack is charging

Green	Battery pack is charged
Red	Battery pack and/or battery charger is over or under the appropriate temperature range
Red blinking	Battery pack charging fault*

\*Refer to [Troubleshooting \(page 18\)](#) for more information.

**Important:** The battery can be left on the charger for short periods between uses.

If the battery will not be used for longer periods, remove the battery from the charger; refer to [Storage \(page 17\)](#).

# Advancing the Line Using the Bump Feed

1. Run the tool at full throttle.
2. Tap the bump button on the ground to advance the line. The line advances each time the bump button is tapped. Do not hold the bump button on the ground.

**Note:** The line trimming cut-off blade on the grass deflector cuts the line to the correct length.

**Note:** If the line is worn too short, you may not be able to advance the line by tapping it on the ground. If so, release both triggers and refer to [Advancing the Line Manually \(page 14\)](#).

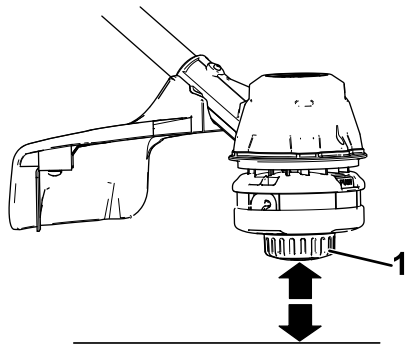

Figure 14

g268494

1. Bump button
- 

# Advancing the Line Manually

Remove the battery pack from the trimmer, then push the bump button at the base of the spool retainer while pulling on the trimmer line to manually advance the line.

# Adjusting the Cutting Swath

The trimmer comes from the factory with a cutting swath of 36.6 cm (14 inches) as shown in A of [Figure 15](#). Refer to the following instructions to adjust the swath to 40.6 cm (16 inches) as shown in D of [Figure 15](#).

1. Remove the swath blade from the bottom of the guard by removing the 2 screws holding it in place using the provided Allen wrench (B of [Figure 15](#)) and rotate the swath blade 180°.
2. Once the swath blade is rotated, install it onto the guard using the 2 screws previously removed (C of [Figure 15](#)).

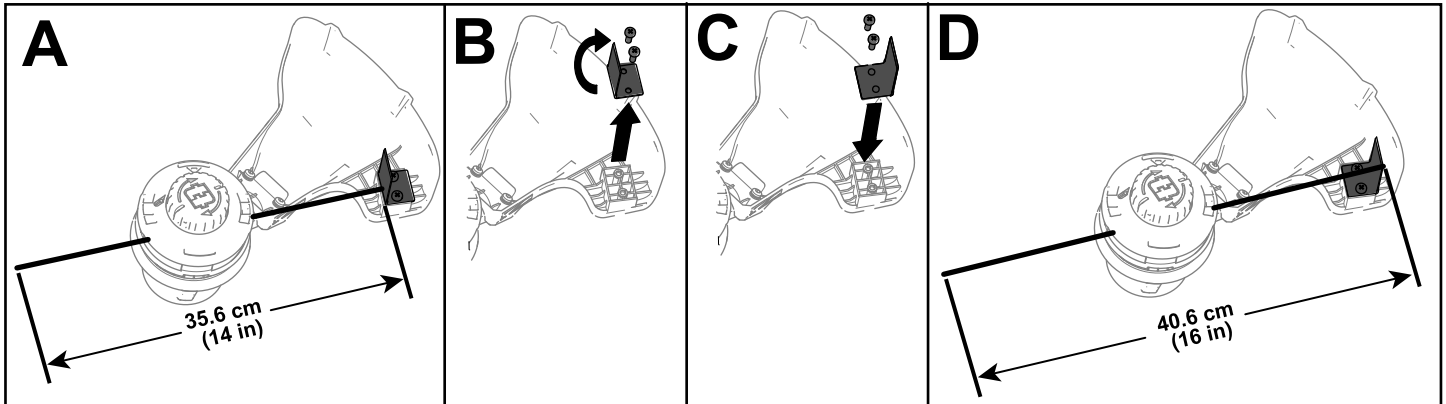

Figure 15

g281965

## Operating Tips

- Keep the trimmer tilted toward the area being cut; this is the best cutting area.
- The string trimmer cuts when you move it from left to right. This prevents the trimmer from throwing debris at you.
- Use the tip of the string to do the cutting; do not force the string head into uncut grass.
- Wire and picket fences can cause the string to wear rapidly and even break. Stone and brick walls, curbs, and wood can also cause the string to wear rapidly.
- Avoid trees and shrubs. The string can easily damage tree bark, wood moldings, siding, and fence posts.

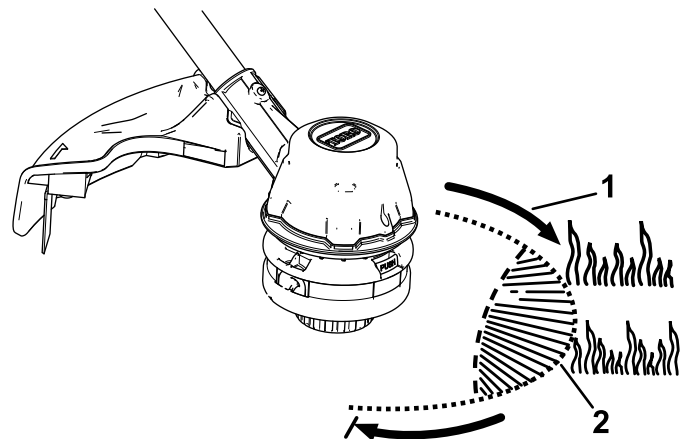

Figure 16

g268453

1. Direction of rotation
2. String path

# Maintenance

After each use of the trimmer, complete the following:

1. Remove the battery from the trimmer.
2. Wipe the trimmer clean with a damp cloth. Do not hose the trimmer down or submerge it in water.

## ⚠ CAUTION

The line cutoff blade on the deflector is sharp and can cut you.

Do not use your hands to clean the deflector shield and blade.

3. Wipe or scrape clean the cutting head area any time there is an accumulation of debris.
4. Check and tighten all fasteners. If any part is damaged or lost, repair or replace it.
5. Brush debris away from air intake vents and exhaust on motor housing to prevent the motor from overheating.

head until the line outside the string is evenly divided on each side.

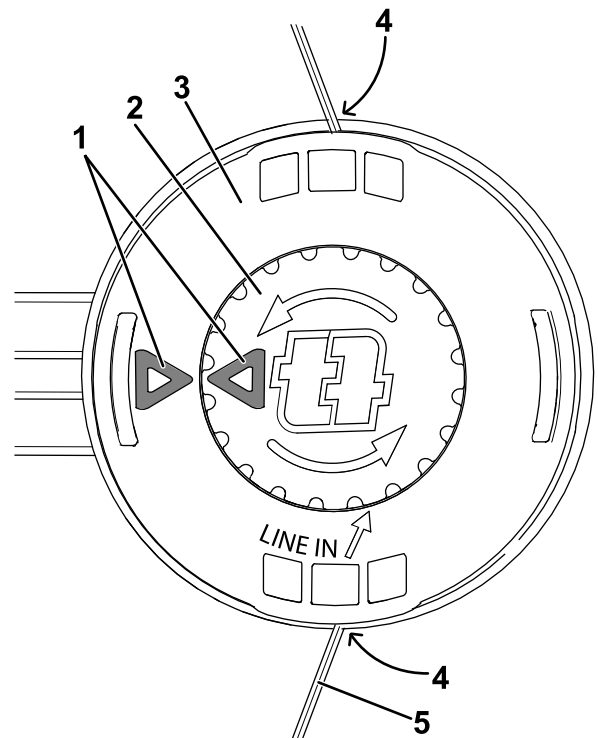

g278518

# Replacing the String

**Important:** Use only 2 mm (0.080 inch) diameter monofilament string (the manufacturer Part No. 88611) or 2.4 mm (0.095 inch) diameter twisted monofilament string (the manufacturer Part No. 88612).

1. Remove the battery pack and clean any debris from the trimmer head.
2. Remove any old string on the spool by repetitively pressing the bump button while pulling the line out equally from both sides of the trimmer.
3. Cut 1 piece of string according to the following specifications.
  - If you are using 2 mm (0.080 inch) string, cut one piece of line approximately 4.9 m (16 ft).
  - If you are using 2.4 mm (0.095 inch) twisted string, cut one piece of line approximately 3 m (10 ft).

**Note:** Do not use any other gauge or type of string, as this could damage the trimmer.

4. Press and turn the knob on the string head until arrow on the knob aligns with arrow on the string head (Figure 17).
5. Insert 1 end of the line at an angle into the LINE IN eyelet and push the line through the string head track until it comes out through the eyelet on the other side. Pull the line through the string

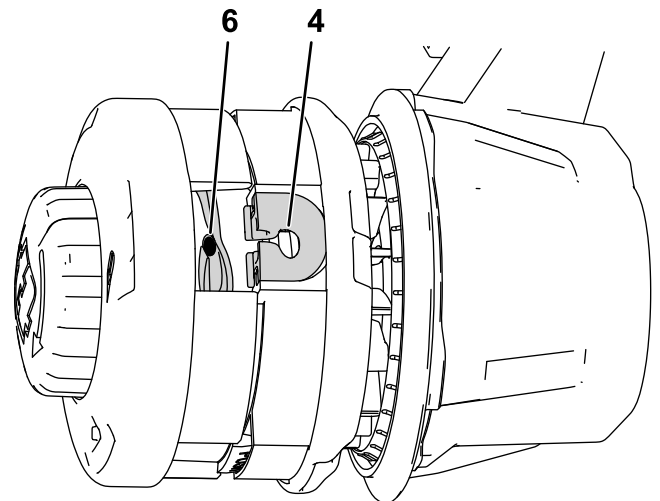

g285202

**Figure 17**

Disassembled view shown for clarity

- |                |           |
|----------------|-----------|
| 1. Arrows      | 4. Eyelet |
| 2. Knob        | 5. String |
| 3. String head | 6. Track  |

**Important:** Do not disassemble the trimmer head.

6. Hold the string head in place with one hand. With your other hand, rotate the knob in the direction shown by the arrows (counterclockwise).
7. Wind the line, leaving about 102 mm (4 inches) extending beyond the eyelet on each side.



# Storage

**Important:** Store the tool, battery pack, and charger only in temperatures that are within the appropriate range; refer to [Specifications \(page 11\)](#).

**Important:** If you are storing the battery pack for the off-season, charge it until 2 or 3 LED indicators turn green on the battery. Do not store a fully charged or fully depleted battery. When you are ready to use the machine again, charge the battery pack until the left indicator light turns green on the charger or all 4 LED indicators turn green on the battery.

- Disconnect the product from the power supply (i.e., remove the plug from the power supply or the battery pack) and check for damage after use.
- Do not store the machine with the battery pack installed.
- Clean all foreign material from the product.
- When not in use, store the tool, battery pack, and battery charger out of the reach of children.
- Keep the tool, battery pack, and battery charger away from corrosive agents, such as garden chemicals and de-icing salts.
- To reduce the risk of serious personal injury, do not store the battery pack outside or in vehicles.
- Store the tool, battery pack, and battery charger in an enclosed clean, dry area.

## Preparing the Battery Pack for Recycling

**Important:** Upon removal, cover the terminals of the battery pack with heavy-duty adhesive tape. Do not attempt to destroy or disassemble the battery pack or remove any of its components.



Lithium-ion battery packs labeled with the Call2Recycle seal can be recycled at any participating retailer or battery recycling facility in the Call2Recycle program (US and Canada only). To locate a participating retailer or facility closest to you, please call 1-800-822-8837 or visit [www.call2recycle.org](http://www.call2recycle.org). If you cannot locate a participating retailer or facility nearby, or if your rechargeable battery is not labeled with the Call2Recycle seal, please contact your local municipality for more information on how to responsibly recycle the battery. If you are located outside of the US and Canada, please contact your authorized Toro distributor.

# Troubleshooting

Perform only the steps described in these instructions. All further inspection, maintenance, and repair work must be performed by an authorized service center or a similarly qualified specialist if you cannot solve the problem yourself.

Problem	Possible Cause	Corrective Action
The tool does not start.	<ol style="list-style-type: none"> <li>1. The battery is not fully installed in the tool.</li> <li>2. The battery pack is not charged.</li> <li>3. The battery pack is damaged.</li> <li>4. There is another electrical problem with the tool.</li> </ol>	<ol style="list-style-type: none"> <li>1. Remove and then replace the battery into the tool, making sure that it is fully installed and latched.</li> <li>2. Remove the battery pack from the tool and charge it.</li> <li>3. Replace the battery pack.</li> <li>4. Contact an Authorized Service Dealer.</li> </ol>
The tool does not reach full power.	<ol style="list-style-type: none"> <li>1. The battery pack charge capacity is too low.</li> <li>2. The air vents are blocked.</li> </ol>	<ol style="list-style-type: none"> <li>1. Remove the battery pack from the tool and fully charge the battery pack.</li> <li>2. Clean the air vents.</li> </ol>
The tool is producing excessive vibration or noise.	<ol style="list-style-type: none"> <li>1. There is debris on the drum area on the trimmer.</li> <li>2. The spool is not properly wound.</li> </ol>	<ol style="list-style-type: none"> <li>1. Clean any debris off of the drum area.</li> <li>2. Advance the line using the trigger switch and/or remove the line on the spool and wind the spool again.</li> </ol>
The battery pack loses charge quickly.	<ol style="list-style-type: none"> <li>1. The battery pack is over or under the appropriate temperature range.</li> </ol>	<ol style="list-style-type: none"> <li>1. Move the battery pack to a place where it is dry and the temperature is between 5°C (41°F) and 40°C (104°F).</li> </ol>
The battery charger is not working.	<ol style="list-style-type: none"> <li>1. The battery charger is over or under the appropriate temperature range.</li> <li>2. The outlet that the battery charger is plugged into does not have power.</li> </ol>	<ol style="list-style-type: none"> <li>1. Unplug the battery charger and move it to a place where it is dry and the temperature is between 5°C (41°F) and 40°C (104°F).</li> <li>2. Contact your licensed electrician to repair the outlet.</li> </ol>
The LED indicator light on the battery charger is red.	<ol style="list-style-type: none"> <li>1. The battery charger and/or battery pack is over or under the appropriate temperature range.</li> </ol>	<ol style="list-style-type: none"> <li>1. Unplug the battery charger and move the battery charger and battery pack to a place where it is dry and the temperature is between 5°C (41°F) and 40°C (104°F).</li> </ol>
The LED indicator light on the battery charger is blinking red.	<ol style="list-style-type: none"> <li>1. There is an error in the communication between the battery pack and the charger.</li> <li>2. The battery pack is weak.</li> </ol>	<ol style="list-style-type: none"> <li>1. Remove the battery pack from the battery charger, unplug the battery charger from the outlet, and wait 10 seconds. Plug the battery charger into the outlet again and place the battery pack on the battery charger. If the LED indicator light on the battery charger is still blinking red, repeat this procedure again. If the LED indicator light on the battery charger is still blinking red after 2 attempts, properly dispose of the battery pack at a battery recycling facility.</li> <li>2. Properly dispose of the battery pack at a battery recycling facility.</li> </ol>
The tool does not run or run continuously.	<ol style="list-style-type: none"> <li>1. There is moisture on the leads of the battery pack.</li> <li>2. The battery is not fully installed into the tool.</li> </ol>	<ol style="list-style-type: none"> <li>1. Allow the battery pack to dry or wipe it dry.</li> <li>2. Remove and then replace the battery into the tool making sure that it is fully installed and latched.</li> </ol>

# California Proposition 65 Warning Information

## What is this warning?

You may see a product for sale that has a warning label like the following:



**WARNING: Cancer and Reproductive Harm—[www.p65Warnings.ca.gov](http://www.p65Warnings.ca.gov).**

## What is Prop 65?

Prop 65 applies to any company operating in California, selling products in California, or manufacturing products that may be sold in or brought into California. It mandates that the Governor of California maintain and publish a list of chemicals known to cause cancer, birth defects, and/or other reproductive harm. The list, which is updated annually, includes hundreds of chemicals found in many everyday items. The purpose of Prop 65 is to inform the public about exposure to these chemicals.

Prop 65 does not ban the sale of products containing these chemicals but instead requires warnings on any product, product packaging, or literature with the product. Moreover, a Prop 65 warning does not mean that a product is in violation of any product safety standards or requirements. In fact, the California government has clarified that a Prop 65 warning "is not the same as a regulatory decision that a product is 'safe' or 'unsafe.'" Many of these chemicals have been used in everyday products for years without documented harm. For more information, go to <https://oag.ca.gov/prop65/faqs-view-all>.

A Prop 65 warning means that a company has either (1) evaluated the exposure and has concluded that it exceeds the "no significant risk level"; or (2) has chosen to provide a warning based on its understanding about the presence of a listed chemical without attempting to evaluate the exposure.

## Does this law apply everywhere?

Prop 65 warnings are required under California law only. These warnings are seen throughout California in a wide range of settings, including but not limited to restaurants, grocery stores, hotels, schools, and hospitals, and on a wide variety of products. Additionally, some online and mail order retailers provide Prop 65 warnings on their websites or in catalogs.

## How do the California warnings compare to federal limits?

Prop 65 standards are often more stringent than federal and international standards. There are various substances that require a Prop 65 warning at levels that are far lower than federal action limits. For example, the Prop 65 standard for warnings for lead is 0.5 µg/day, which is well below the federal and international standards.

## Why don't all similar products carry the warning?

- Products sold in California require Prop 65 labelling while similar products sold elsewhere do not.
- A company involved in a Prop 65 lawsuit reaching a settlement may be required to use Prop 65 warnings for its products, but other companies making similar products may have no such requirement.
- The enforcement of Prop 65 is inconsistent.
- Companies may elect not to provide warnings because they conclude that they are not required to do so under Prop 65; a lack of warnings for a product does not mean that the product is free of listed chemicals at similar levels.

## Why does Toro include this warning?

Toro has chosen to provide consumers with as much information as possible so that they can make informed decisions about the products they buy and use. Toro provides warnings in certain cases based on its knowledge of the presence of one or more listed chemicals without evaluating the level of exposure, as not all the listed chemicals provide exposure limit requirements. While the exposure from Toro products may be negligible or well within the "no significant risk" range, out of an abundance of caution, Toro has elected to provide the Prop 65 warnings. Moreover, if Toro does not provide these warnings, it could be sued by the State of California or by private parties seeking to enforce Prop 65 and subject to substantial penalties.



**Count on it.**