



Count on it.

Operator's Manual

**Groundsmaster® 4500-D or
4700-D Rotary Mower**

Model No. 30893—Serial No. 406680000 and Up

Model No. 30893TE—Serial No. 406680000 and Up

Model No. 30899—Serial No. 406680000 and Up

Model No. 30899TE—Serial No. 406680000 and Up



This product complies with all relevant European directives; for details, please see the separate product specific Declaration of Conformity (DOC) sheet.

Please refer to the engine manufacturer's information included with the machine.

Introduction

This machine is a ride-on, rotary-blade lawn mower intended to be used by professional, hired operators in commercial applications. It is primarily designed for cutting grass on well-maintained lawns in parks, sports fields, and on commercial grounds. Using this product for purposes other than its intended use could prove dangerous to you and bystanders.

Read this information carefully to learn how to operate and maintain your product properly and to avoid injury and product damage. You are responsible for operating the product properly and safely.

Visit www.Toro.com for product safety and operation training materials, accessory information, help finding a dealer, or to register your product.

Whenever you need service, genuine Toro parts, or additional information, contact an Authorized Service Dealer or Toro Customer Service and have the model and serial numbers of your product ready. [Figure 1](#) identifies the location of the model and serial numbers on the right front frame of the product. Write the numbers in the space provided.

Important: With your mobile device, you can scan the QR code on the serial number decal (if equipped) to access warranty, parts, and other product information.

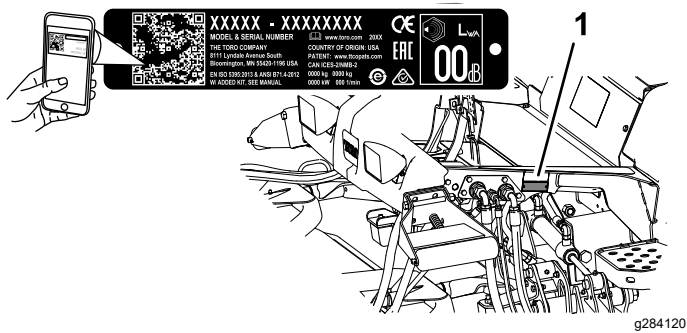

Figure 1

1. Model and serial number location

Model No. _____
Serial No. _____

This manual identifies potential hazards and has safety messages identified by the safety-alert symbol ([Figure 2](#)), which signals a hazard that may cause serious injury or death if you do not follow the recommended precautions.



Figure 2

g000502

1. Safety-alert symbol

This manual uses 2 words to highlight information. **Important** calls attention to special mechanical information and **Note** emphasizes general information worthy of special attention.

Contents

Safety	4	Operating Tips	39
General Safety	4	After Operation	40
Safety and Instructional Decals	5	General Safety	40
Setup	12	Using the Cutting-Unit Storage Lanyard	40
1 Installing the Decals (CE Machines Only)	12	Using the Transport Latches	41
2 Installing the Hood Latch.....	13	Hauling the Machine	41
3 Adjusting the Roller Scraper.....	14	Pushing or Towing the Machine	41
4 Installing the Mulching Baffle.....	14	Locating the Tie-Down Points	42
5 Preparing the Machine	14	Maintenance	43
Product Overview	16	Maintenance Safety.....	43
Controls	16	Recommended Maintenance Schedule(s)	43
Specifications	19	Daily Maintenance Checklist.....	44
Machine Specifications.....	20	Pre-Maintenance Procedures	46
Cutting Unit Specifications.....	20	Lifting the Machine	46
Attachments/Accessories	20	Opening the Hood	46
Before Operation	21	Accessing the Hydraulic Lift Compartment.....	47
Before Operation Safety	21	Lubrication	47
Checking the Engine-Oil Level.....	21	Greasing the Bearings and Bushings	47
Checking the Cooling System.....	21	Engine Maintenance	49
Checking the Hydraulic System	21	Engine Safety	49
Draining the Water Separator	21	Servicing the Air Cleaner	49
Checking the Rear Axle and Gearbox for Leaks	21	Servicing the Engine Oil.....	50
Filling the Fuel Tank.....	21	Fuel System Maintenance	51
Checking the Tire Pressure.....	23	Draining the Fuel Tank.....	51
Checking the Torque of the Wheel Lug Nuts	23	Inspecting the Fuel Lines and Connections.....	51
Adjusting the Height of Cut	23	Servicing the Fuel-Water Separator	52
Checking the Interlock Switches	24	Servicing the Fuel Filter	53
Checking the Blade-Stopping Time.....	24	Cleaning the Fuel-Pickup Tube Screen.....	53
Selecting a Blade.....	25	Priming the Fuel System.....	54
Choosing Accessories.....	26	Electrical System Maintenance	54
Using the InfoCenter LCD Display	27	Electrical System Safety	54
Using the Menus.....	28	Checking the Battery Condition.....	54
Protected Menus	29	Charging and Connecting the Battery	54
During Operation	31	Locating the Fuses	56
During Operation Safety	31	Drive System Maintenance	57
Understanding the Operating Characteristics of the Machine	33	Checking for End-Play in the Planetary Drives.....	57
Operating the Machine	33	Checking the Planetary Gear-Drive Lubricant.....	57
Using the High and Low Speed Range Switch	34	Changing the Planetary-Gear-Drive Oil	58
Using the Traction Pedal.....	34	Checking the Rear Axle and Gearbox for Leaks	59
Setting the Maximum Traction Speed (Pedal Stop)	35	Checking the Rear-Axle Lubricant	59
Using the Brake Pedals	35	Changing the Rear-Axle Lubricant	60
Operating the Cruise Control	36	Checking the Rear-Axle-Gearbox Lubricant.....	60
Understanding the Acceleration Mode	37	Checking the Rear Wheel Toe-In	60
Understanding the Turnaround Mode	37	Cooling System Maintenance	61
Understanding Counterbalance.....	37	Cooling System Safety	61
Understanding Toro Smart Power™	37	Checking the Cooling System.....	61
Starting the Engine	37	Cleaning the Cooling System.....	62
Shutting Off the Engine.....	38	Brake Maintenance	63
Cutting Grass with the Machine	38	Adjusting the Service Brakes	63
Operating the Engine-Cooling Fan.....	38	Belt Maintenance	64
		Servicing the Alternator Belt	64

Safety

This machine has been designed in accordance with ANSI B71.4-2017 and with EN ISO 5395 when you complete the setup procedures.

General Safety

This product is capable of amputating hands and feet and of throwing objects. Always follow all safety instructions to avoid serious personal injury.

- Read and understand the contents of this *Operator's Manual* before starting the engine.
- Use your full attention while operating the machine. Do not engage in any activity that causes distractions; otherwise, injury or property damage may occur.
- Do not operate the machine without all guards and other safety protective devices in place and functioning properly on the machine.
- Keep your hands and feet away from rotating parts. Keep clear of the discharge opening.
- Keep bystanders and children out of the operating area. Never allow children to operate the machine.
- Shut off the engine, remove the key, and wait for all movement to stop before you leave the operator's position. Allow the machine to cool before adjusting, servicing, cleaning, or storing it.

Improperly using or maintaining this machine can result in injury. To reduce the potential for injury, comply with these safety instructions and always pay attention to the safety-alert symbol , which means Caution, Warning, or Danger—personal safety instruction. Failure to comply with these instructions may result in personal injury or death.

Hydraulic System Maintenance	64
Hydraulic System Safety.....	64
Servicing the Hydraulic Fluid	65
Checking the Hydraulic Lines and Hoses.....	68
Cutting Unit Maintenance	68
Removing the Cutting Units	68
Installing the Cutting Units	69
Servicing the Front Roller	69
Blade Maintenance	70
Blade Safety	70
Servicing the Blade Plane.....	70
Removing and Installing the Cutting-Unit Blade(s)	71
Inspecting and Sharpening the Cutting Unit Blade(s)	71
Storage	73
Storage Safety.....	73
Preparing the Machine for Storage	73
Preparing a Cutting Unit.....	73

Safety and Instructional Decals



Safety decals and instructions are easily visible to the operator and are located near any area of potential danger. Replace any decal that is damaged or missing.

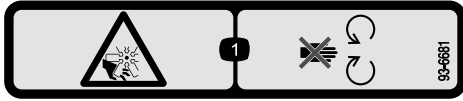

93-6681

decal93-6681

1. Cutting/dismemberment hazard, fan—stay away from moving parts.

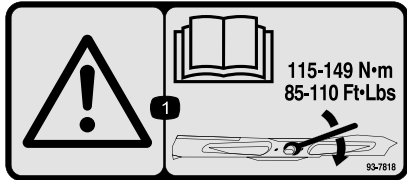

93-7818

decal93-7818

1. Warning—read the *Operator's Manual* for instructions on torquing the blade bolt/nut to 115 to 149 N·m (85 to 110 ft-lb).



98-4387

decal98-4387

1. Warning—wear hearing protection.

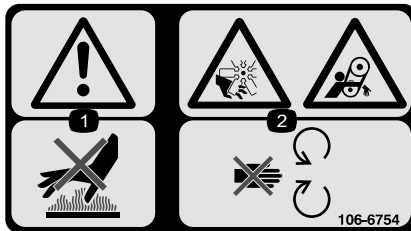

106-6754

decal106-6754

1. Warning—do not touch the hot surface.
2. Cutting/dismemberment hazard, fan and entanglement hazard, belt—stay away from moving parts.

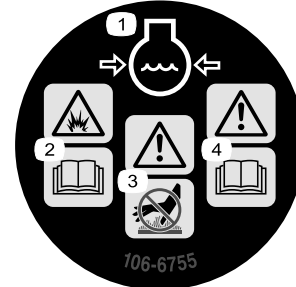

106-6755

decal106-6755

1. Engine coolant under pressure.
2. Explosion hazard—read the *Operator's Manual*.
3. Warning—do not touch the hot surface.
4. Warning—read the *Operator's Manual*.

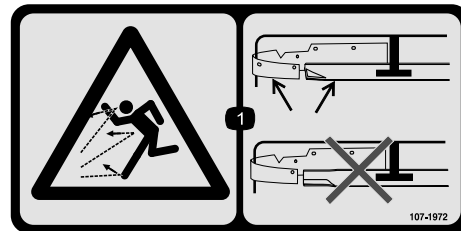

107-1972

decal107-1972

1. Thrown object hazard—use a standard blade when the mulch baffle is installed; do not use a high-lift blade when the mulch baffle is installed.

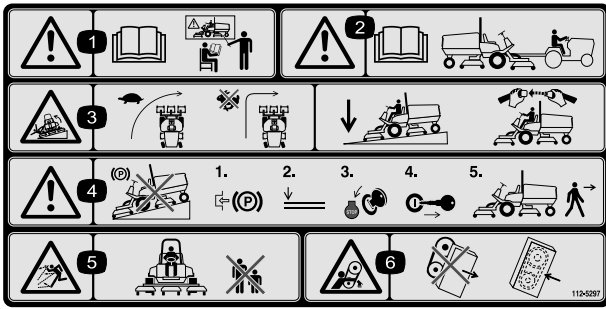

decal112-5297

112-5297

1. Warning—read the *Operator's Manual*; do not operate the machine unless you are trained.
2. Warning—read the *Operator's Manual* before towing the machine.
3. Tipping hazard— turn at low speeds; do not turn at high speeds; lower the cutting unit when driving down slopes; use a roll over protection system and wear the seatbelt.
4. Warning—do not park the machine on slopes; engage the parking brake, lower the cutting units, shut off the engine, and remove the key before leaving the machine.
5. Thrown object hazard—keep bystanders away.
6. Entanglement hazard, belt—stay away from moving parts; keep all guards and shields in place.

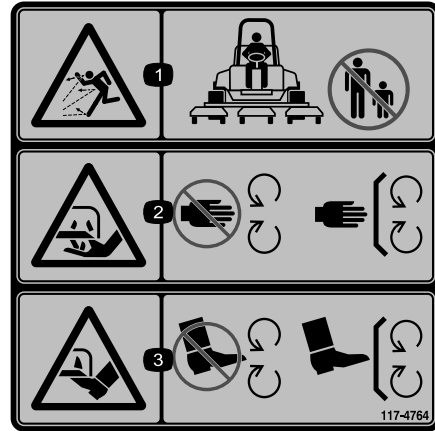

decal117-4764

117-4764

1. Thrown object hazard—keep bystanders away.
2. Cutting hazard of hand, mower blade—stay away from moving parts; keep all guards and shields in place.
3. Cutting hazard of foot, mower blade—stay away from moving parts; keep all guards and shields in place.

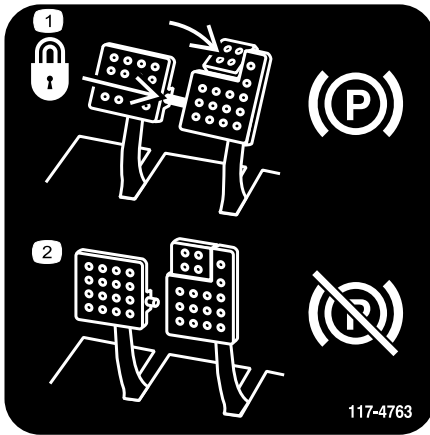

decal117-4763

117-4763

1. To engage the parking brake, secure the brake pedals with the locking pin, press the parking-brake pedals and engage the toe pedal.
2. To disengage the parking brake, disengage the locking pin and release the pedals.

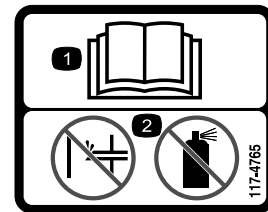

decal117-4765

117-4765

1. Read the *Operator's Manual*.
2. Do not use starting aids.



decal117-4766

117-4766

1. Cutting/dismemberment hazard; fan—stay away from moving parts, keep all guards and shields in place.



Battery Symbols

Some or all of these symbols are on your battery.

- | | |
|--|---|
| 1. Explosion hazard | 6. Keep bystanders away from the battery. |
| 2. No fire, open flame, or smoking | 7. Wear eye protection; explosive gases can cause blindness and other injuries. |
| 3. Caustic liquid/chemical burn hazard | 8. Battery acid can cause blindness or severe burns. |
| 4. Wear eye protection. | 9. Flush eyes immediately with water and get medical help fast. |
| 5. Read the <i>Operator's Manual</i> . | 10. Contains lead; do not discard |

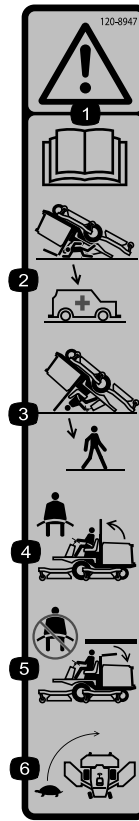

120-8947

decal120-8947

- | | |
|---|---|
| 1. Warning—read the <i>Operator's Manual</i> . | 4. If the roll bar is raised, wear the seat belt. |
| 2. There is no rollover protection when the roll bar is down. | 5. If the roll bar is lowered, do not wear the seat belt. |
| 3. There is rollover protection when the roll bar is up. | 6. Drive slowly when turning. |

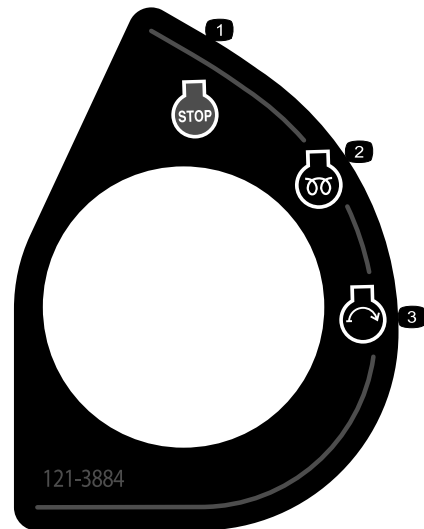

121-3884

decal121-3884

- | | |
|-------------------|-----------------|
| 1. Engine—stop | 3. Engine—start |
| 2. Engine—preheat | |

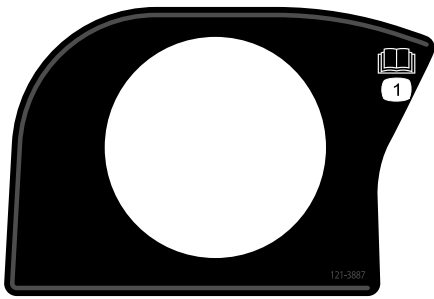

121-3887

decal121-3887

1. Read the *Operator's Manual*.

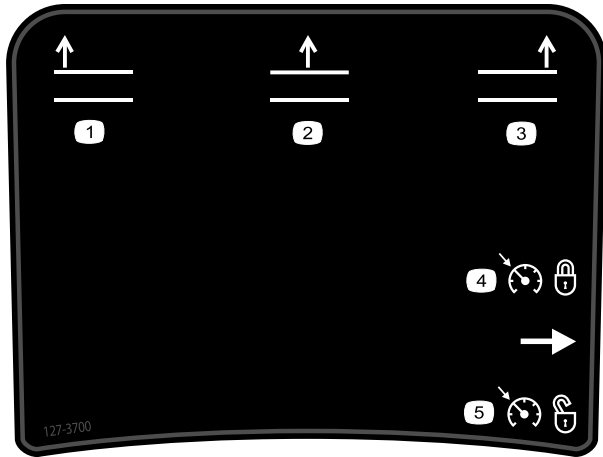

127-3700

decal127-3700

For Groundsmaster 4700 Only

1. Raise the left cutting unit.
2. Raise the center cutting units.
3. Raise the right cutting unit.
4. Set the cruise control.
5. Disengage the cruise control.

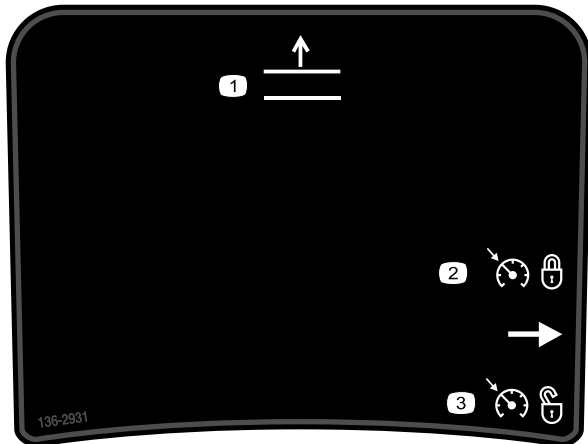

136-2931

decal136-2931

For Groundsmaster 4500 Only

1. Raise the cutting units.
2. Set the cruise control.
3. Disengage the cruise control.

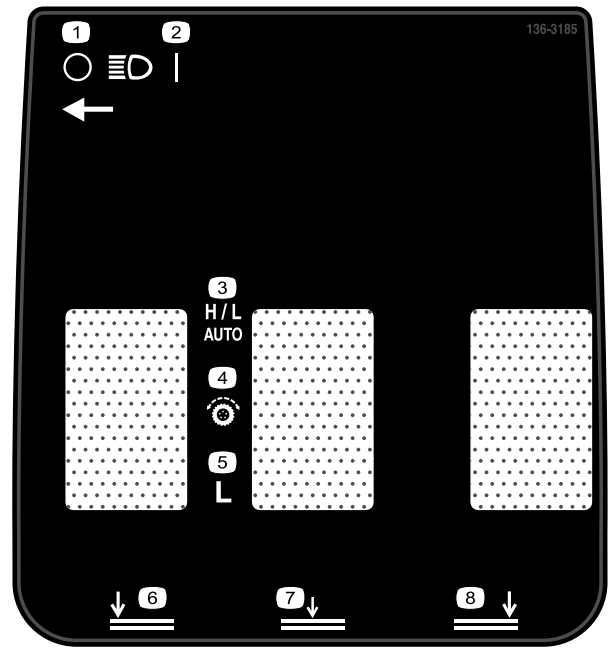

136-3185

decal136-3185

1. Headlights—Off
2. Headlights—On
3. High/Low—Auto
4. Traction controls
5. Low
6. Lower the left cutting unit.
7. Lower the center cutting unit.
8. Lower the right cutting unit.

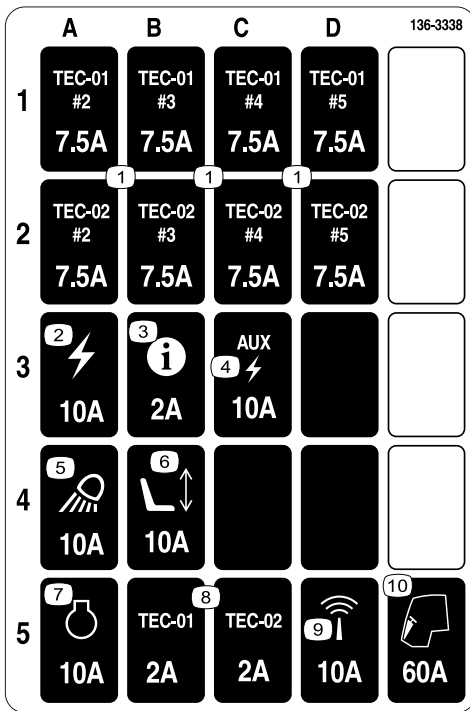

136-3338

decal136-3338

1. TEC—7.5 A
2. Power—10 A
3. InfoCenter—2 A
4. Auxiliary power—10 A
5. Work lights—10 A
6. Power seat—10 A
7. Engine—10 A
8. TEC—2 A
9. Telematics—10 A
10. Cab—60 A



136-3566

decal136-3566

1. Read the *Operator's Manual* for more information on servicing the machine.

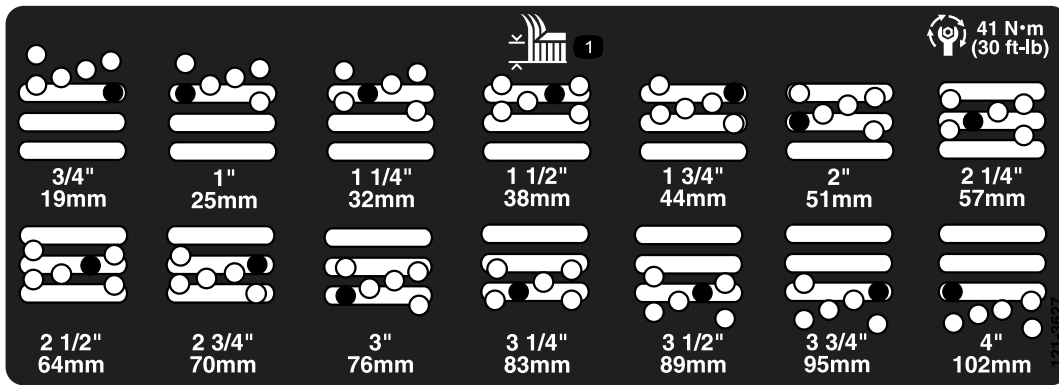

121-3627

decal121-3627

1. Height-of-cut settings

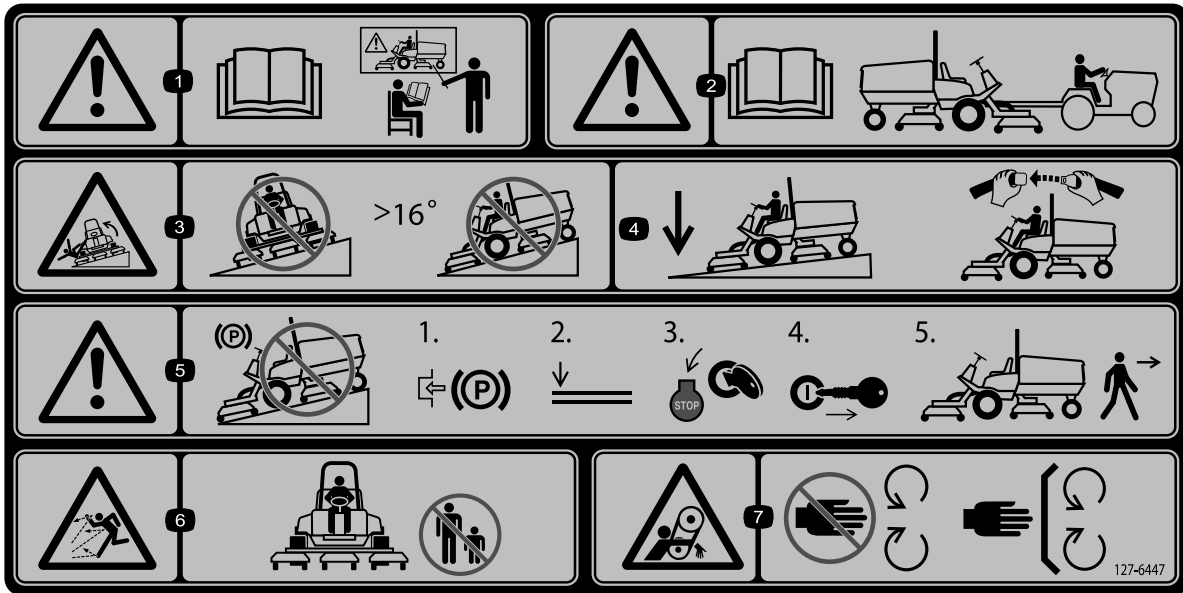

127-6447

decal127-6447

Note: This machine complies with the industry standard stability test in the static lateral and longitudinal tests with the maximum recommended slope indicated on the decal. Review the instructions for operating the machine on slopes in the *Operator's Manual* as well as the conditions in which you would operate the machine to determine whether you can operate the machine in the conditions on that day and at that site. Changes in the terrain can result in a change in slope operation for the machine.

- | | | | |
|--|--|---|--|
| <p>1. Warning—read the <i>Operator's Manual</i>; all operators should be trained before operating the machine.</p> | <p>3. Tipping hazard—do not drive on slopes greater than 16°.</p> | <p>5. Warning—do not park on slopes; engage the parking brake, lower the cutting units, shut off the engine, and remove the key before leaving the machine.</p> | <p>7. Entanglement hazard, belt—stay away from moving parts; keep all guards and shields in place.</p> |
| <p>2. Warning—read the <i>Operator's Manual</i> for towing information.</p> | <p>4. Keep the cutting units lowered while driving down slopes; always wear a seatbelt when operating the machine.</p> | <p>6. Thrown object hazard—keep bystanders away.</p> | |

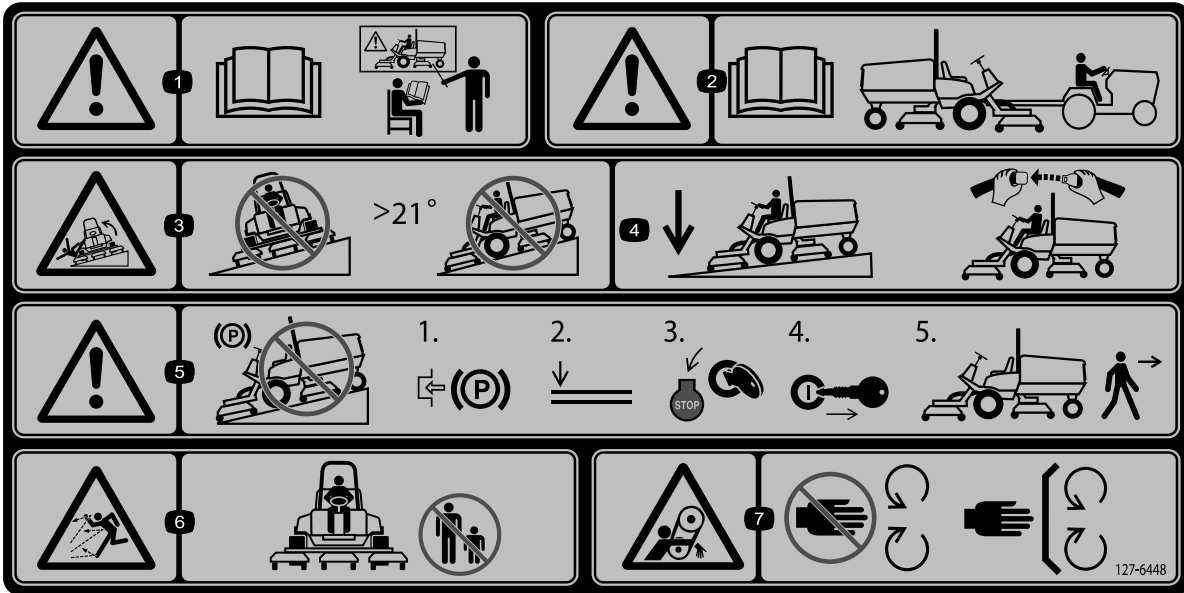

decal127-6448

127-6448

Note: This machine complies with the industry standard stability test in the static lateral and longitudinal tests with the maximum recommended slope indicated on the decal. Review the instructions for operating the machine on slopes in the *Operator's Manual* as well as the conditions in which you would operate the machine to determine whether you can operate the machine in the conditions on that day and at that site. Changes in the terrain can result in a change in slope operation for the machine.

- | | | | |
|--|--|---|--|
| <p>1. Warning—read the <i>Operator's Manual</i>; all operators should be trained before operating the machine.</p> | <p>3. Tipping hazard—do not drive on slopes greater than 21°.</p> | <p>5. Warning—do not park on slopes; engage the parking brake, lower the cutting units, shut off the engine, and remove the key before leaving the machine.</p> | <p>7. Entanglement hazard, belt—stay away from moving parts; keep all guards and shields in place.</p> |
| <p>2. Warning—read the <i>Operator's Manual</i> for towing information.</p> | <p>4. Keep the cutting units lowered while driving down slopes; always wear a seatbelt when operating the machine.</p> | <p>6. Thrown object hazard—keep bystanders away.</p> | |

Setup

Loose Parts

Use the chart below to verify that all parts have been shipped.

Procedure	Description	Qty.	Use
1	Warning decal	1	Replace the decals (CE machines only).
	CE decal	1	
	Production-year decal	1	
2	Hood-latch bracket	1	Install the hood latch (CE machines only).
	Rivet	2	
	Washer	1	
	Screw (1/4 x 2 inches)	1	
	Locknut (1/4 inch)	1	
3	No parts required	–	Adjust the roller scraper (optional).
4	No parts required	–	Install the mulching baffle (optional).
5	No parts required	–	Prepare the machine.

Media and Additional Parts

Description	Qty.	Use
Operator's Manual	1	Review before operating the machine.
Engine owner's manual	1	Refer to the manual for additional maintenance information.
Declaration of Conformity	1	
Ignition keys	2	Start the engine.

Note: Determine the left and right sides of the machine from the normal operating position.

1

Installing the Decals (CE Machines Only)

Parts needed for this procedure:

1	Warning decal
1	CE decal
1	Production-year decal

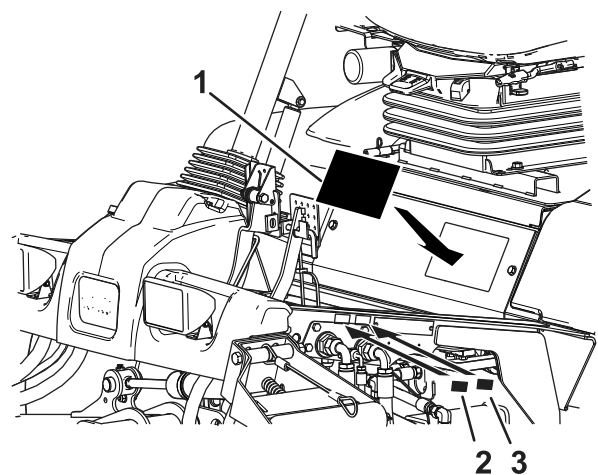

Figure 3

1. Warning decal
2. CE decal
3. Production-year decal

Procedure

On machines requiring CE compliance, replace the warning decal, CE decal, and the production-year decal (Figure 3).

2

Installing the Hood Latch

CE Machines Only

Parts needed for this procedure:

1	Hood-latch bracket
2	Rivet
1	Washer
1	Screw (1/4 x 2 inches)
1	Locknut (1/4 inch)

Procedure

1. Unhook the hood latch from the hood-latch bracket.
2. Remove the 2 rivets securing the hood-latch bracket to the hood (Figure 4).

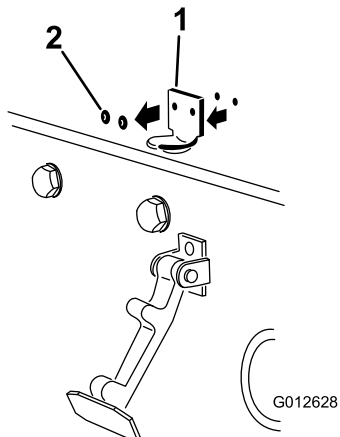

Figure 4

1. Hood-latch bracket
2. Rivets

3. Remove the hood-latch bracket from the hood.
4. While aligning the mounting holes, position the CE lock bracket and the hood-latch bracket onto the hood (Figure 5).

Note: The lock bracket must be against the hood. Do not remove the bolt and nut from the lock-bracket arm.

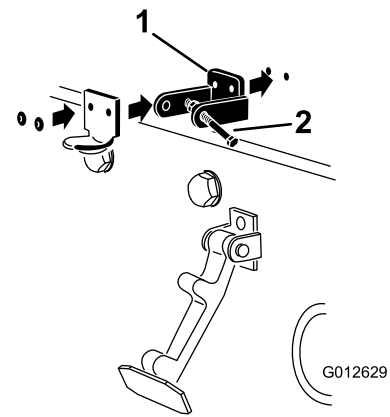

Figure 5

1. CE lock bracket
2. Bolt and nut

5. Align the washers with the holes on the inside of the hood.
6. Rivet the brackets and the washers to the hood (Figure 5).
7. Hook the latch onto the hood-latch bracket (Figure 6).

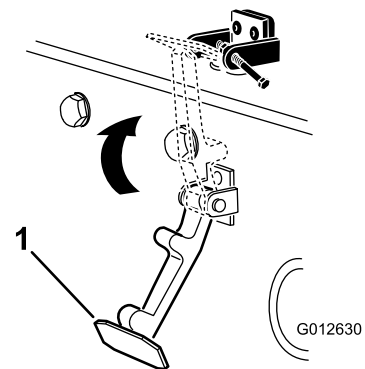

Figure 6

1. Hood latch

8. Install the bolt into the other arm of the hood-latch bracket to lock the latch in position (Figure 7). Tighten the bolt but do not tighten the nut.

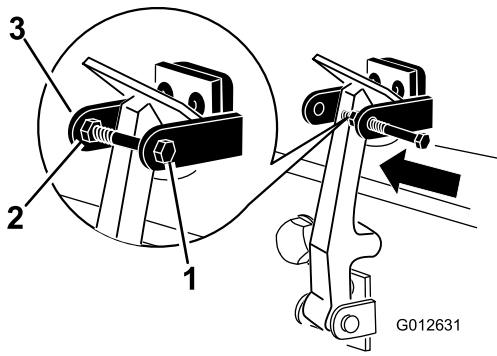

Figure 7

g012631

- | | |
|---------|------------------------------|
| 1. Bolt | 3. Arm of hood-latch bracket |
| 2. Nut | |

4

Installing the Mulching Baffle

Optional

No Parts Required

Procedure

Contact your authorized Toro distributor for the correct mulching baffle.

1. Thoroughly clean debris from the mounting holes on the rear wall and left wall of the chamber.
2. Install the mulching baffle in the rear opening and secure it with 5 flange-head bolts (Figure 9).

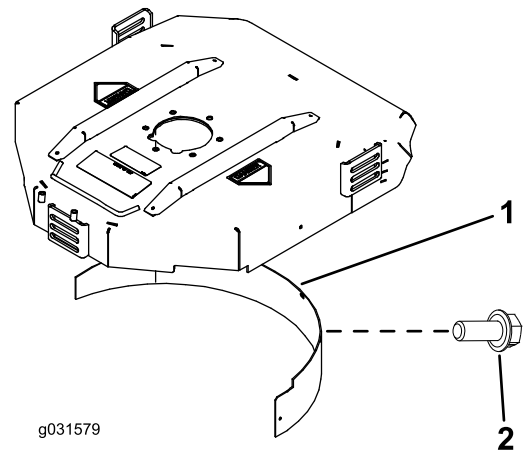

Figure 9

g031579

- | | |
|--------------------|---------------------|
| 1. Mulching baffle | 2. Flange-head bolt |
|--------------------|---------------------|

3. Verify that the mulching baffle does not interfere with the tip of the blade and does not protrude inside the surface of the rear chamber wall.

3

Adjusting the Roller Scraper

Optional

No Parts Required

Procedure

The optional rear roller scraper functions best when there is an even gap of 0.5 to 1 mm (0.02 to 0.04 inch) between the scraper and the roller.

1. Loosen the grease fitting and the mounting screw (Figure 8).

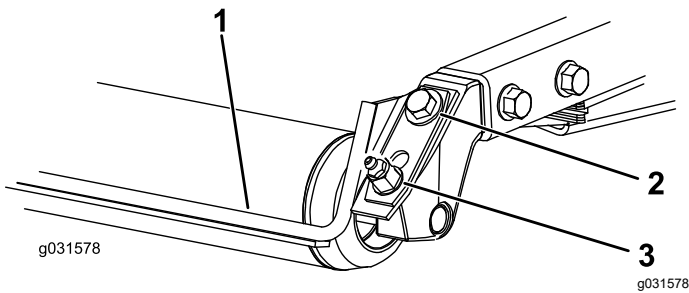

Figure 8

g031578

- | | |
|-------------------|-------------------|
| 1. Roller scraper | 3. Grease fitting |
| 2. Mounting screw | |

2. Slide the scraper up or down until you obtain a gap of 0.5 to 1 mm (0.02 to 0.04 inch) between the rod and the roller.
3. Tighten the grease fitting and screw to 41 N·m (30 ft·lb) in an alternating sequence.

⚠ DANGER

Using the high-lift blade with the mulching baffle could cause the blade to break, resulting in personal injury or death.

Do not use the high-lift blade with the baffle.

5

Preparing the Machine

No Parts Required

Procedure

1. Park the machine on a level surface.
2. For Groundsmaster 4500 and 4700 machines, release the No. 4 and No. 5 cutting-unit cables ([Figure 32](#)).
3. For Groundsmaster 4700 machines, release the No. 6 and No. 7 cutting-unit latches ([Figure 35](#)).
4. Lower the cutting units.
5. Engage the parking brake.
6. Shut off the engine and remove the key.
7. Check the tire pressure before use; refer to [Checking the Tire Pressure \(page 23\)](#).

Important: Maintain pressure in all tires to ensure a good quality-of-cut and proper machine performance. ***Do not underinflate the tires.***

8. Check the rear-axle lubricant level before you start the engine for the first time; refer to [Checking the Rear-Axle Lubricant \(page 59\)](#).
9. Check the engine-oil level before starting the engine; refer to [Checking the Engine-Oil Level \(page 50\)](#).
10. Check the hydraulic-fluid level before starting the engine; refer to [Checking the Hydraulic-Fluid Level \(page 65\)](#).
11. Check the cooling system before starting the engine; refer to [Checking the Cooling System \(page 61\)](#).
12. Grease the machine before use; refer to [Greasing the Bearings and Bushings \(page 47\)](#).

Important: Failure to properly grease the machine will result in premature failure of critical parts.

Product Overview

Controls

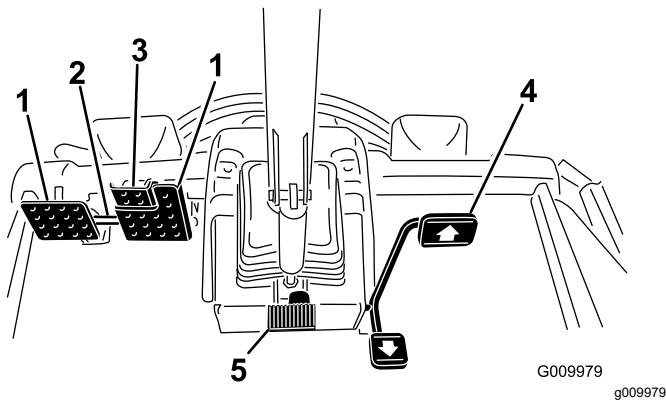

Figure 10

- | | |
|------------------------|------------------------|
| 1. Brake pedal | 4. Traction pedal |
| 2. Pedal-locking latch | 5. Tilt-steering pedal |
| 3. Parking-brake pedal | |

Traction Pedal

The traction pedal (Figure 10) controls forward and reverse operation. Press the top of the pedal to move forward and the bottom to move backward. When the cutting units are fully raised, the pedal controls the engine and traction speed like a car.

Note: In emergency braking situations, remove your foot from the traction pedal and then press the brake pedals. This is the quickest way to stop the machine.

Brake Pedals

There are 2 foot pedals that operate individual wheel brakes for turning assistance, parking, and to aid in better side-hill traction. A latch connects the pedals for parking-brake operation and transport (Figure 10).

Pedal-Locking Latch

The pedal-locking latch connects the pedals together to engage the parking brake (Figure 10).

Parking-Brake Pedal

To engage the parking brake, (Figure 10) connect the pedals together with the pedal-locking latch and push down on the right brake pedal while engaging the toe pedal. To release the parking brake, press 1 of the brake pedals until the parking brake latch retracts.

Tilt-Steering Pedal

To tilt the steering wheel toward you, press the foot pedal down, pull the steering tower toward you to the most comfortable position, and release the pedal (Figure 10). To move the steering wheel away from you, press the foot pedal and release it when the steering wheel reaches the desired operating position.

Key Switch

The key switch (Figure 11) has 3 positions: OFF, ON/PREHEAT, and START.

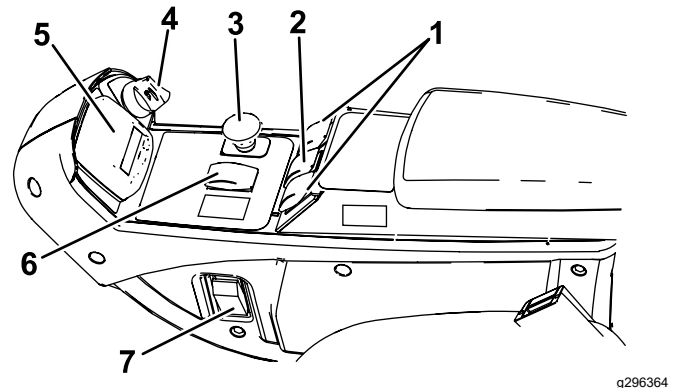

Figure 11

- | | |
|---|------------------------------------|
| 1. Lift switches (Groundsmaster 4700 machine only) | 5. InfoCenter |
| 2. Lift switch (Groundsmaster 4500 and 4700 machines) | 6. High and low speed range switch |
| 3. PTO switch | 7. Light switch |
| 4. Key switch | |

PTO Switch

The PTO switch has 2 positions: OUT (ENGAGE) and IN (DISENGAGE). Pull the PTO button out to engage the cutting-unit blades. Push the button in to disengage the cutting-unit blades (Figure 11).

High and Low Speed Range Switch

This switch (Figure 11) controls the machines 2 speed ranges; high and low.

Select the H/L AUTO position to allow the machine to automatically select high or low speed.

Select the LOW position to manually override to low speed only.

You can change the switch position at any time, but the machine will only switch between speed ranges when the traction pedal is in neutral and the machine is stopped.

Note: To get to high speed in the H/L AUTO position, disengage the PTO and fully raise the cutting units.

Note: If you have the switch in the H/L AUTO position, you cannot lower the decks from the fully-raised position unless the traction pedal is in neutral and the machine is stopped.

Cruise-Control Switch

The cruise-control switch locks in the cruise control to maintain the desired ground speed (Figure 12). Pressing the rear of the switch turns off the cruise control, the middle position of the switch enables the cruise-control function, and the front of the switch sets the desired ground speed.

Once the cruise control is set, you can change the speed using the InfoCenter (Figure 30).

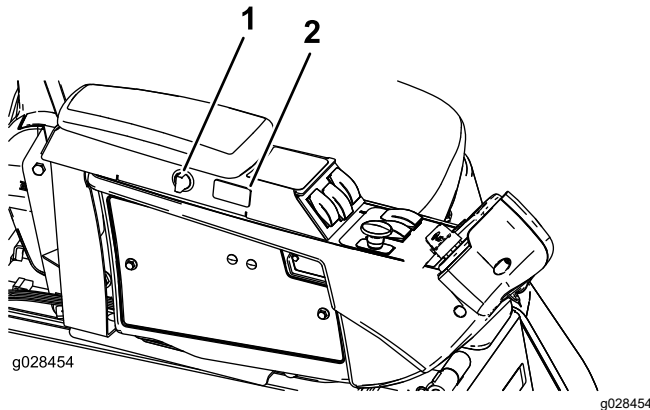

Figure 12

1. Power point
2. Cruise-control switch

Lift Switches

The lift switches raise and lower the cutting units (Figure 11). Press the switches forward to lower the cutting units and rearward to raise the cutting units. When starting the machine, with the cutting units in the down position, press the lift switch down to allow the cutting units to float and mow.

Note: The cutting units do not lower while in the high-speed range and they do not raise or lower if you are out of the seat. Also, the cutting units lower with the key in the ON position and you are in the seat.

Light Switch

Press the light switch upward to turn the lights to the ON position (Figure 11).

Press the light switch downward to turn the lights to the OFF position.

Power Point

Use the power point (Figure 13) to power optional 12 V electrical accessories.

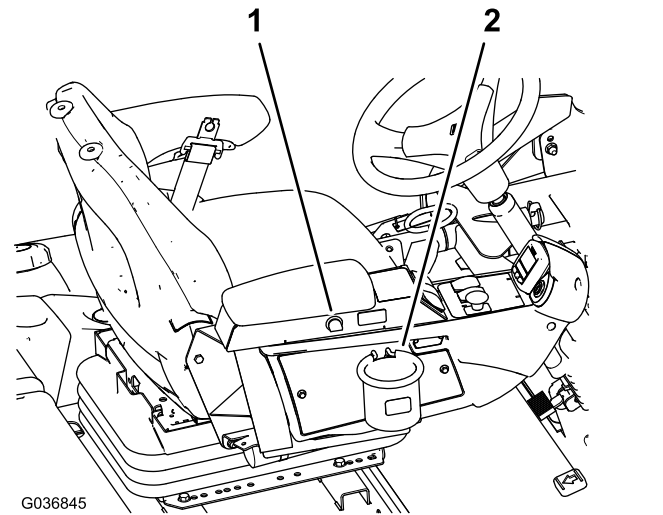

Figure 13

1. Power point
2. Bag holder

Bag Holder

Use the bag holder for storage (Figure 13).

Seat Adjustments

Seat-Adjustment Lever

Move the seat adjustment lever on the side of the seat outward, slide the seat to the desired position, and release the lever to lock the seat into position (Figure 14).

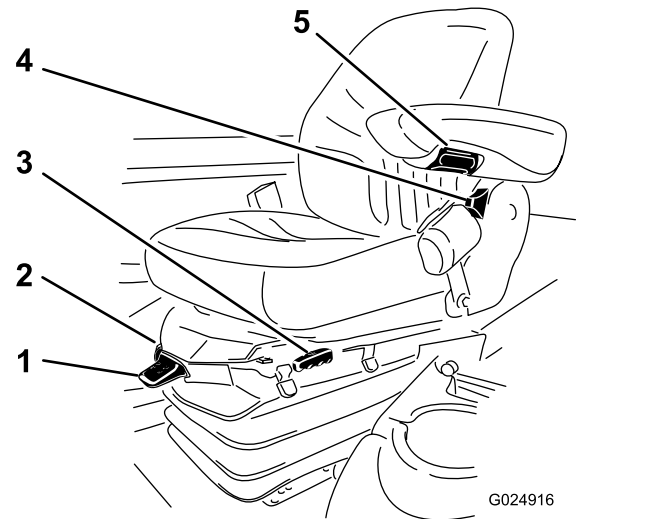

Figure 14

1. Weight gauge
2. Weight adjustment lever
3. Seat adjustment lever
4. Seat-back adjustment lever
5. Armrest adjustment knob

Armrest Adjustment Knob

Rotate the knob to adjust the armrest angle ([Figure 14](#)).

Seat-Back Adjustment Lever

Move the lever to adjust the seat-back angle ([Figure 14](#)).

Weight Gauge

The weight gauge indicates when the seat is adjusted to the operator's weight ([Figure 14](#)). Adjust the height by positioning the suspension within the range of the green region.

Weight Adjustment Lever

Use this lever to adjust the seat to your weight ([Figure 14](#)). Pull the lever up to increase the air pressure and push the lever down to decrease the air pressure. The proper adjustment is correct when the weight gauge is in the green region.

InfoCenter LCD Display

The InfoCenter LCD display ([Figure 11](#)) shows information about your machine, such as the operating status, various diagnostics, and other information about the machine

The screens that display depend on which buttons you select. The purpose of each button may change depending on what is required at the time.

Specifications

4500 Series ■
 4700 Series ■+■

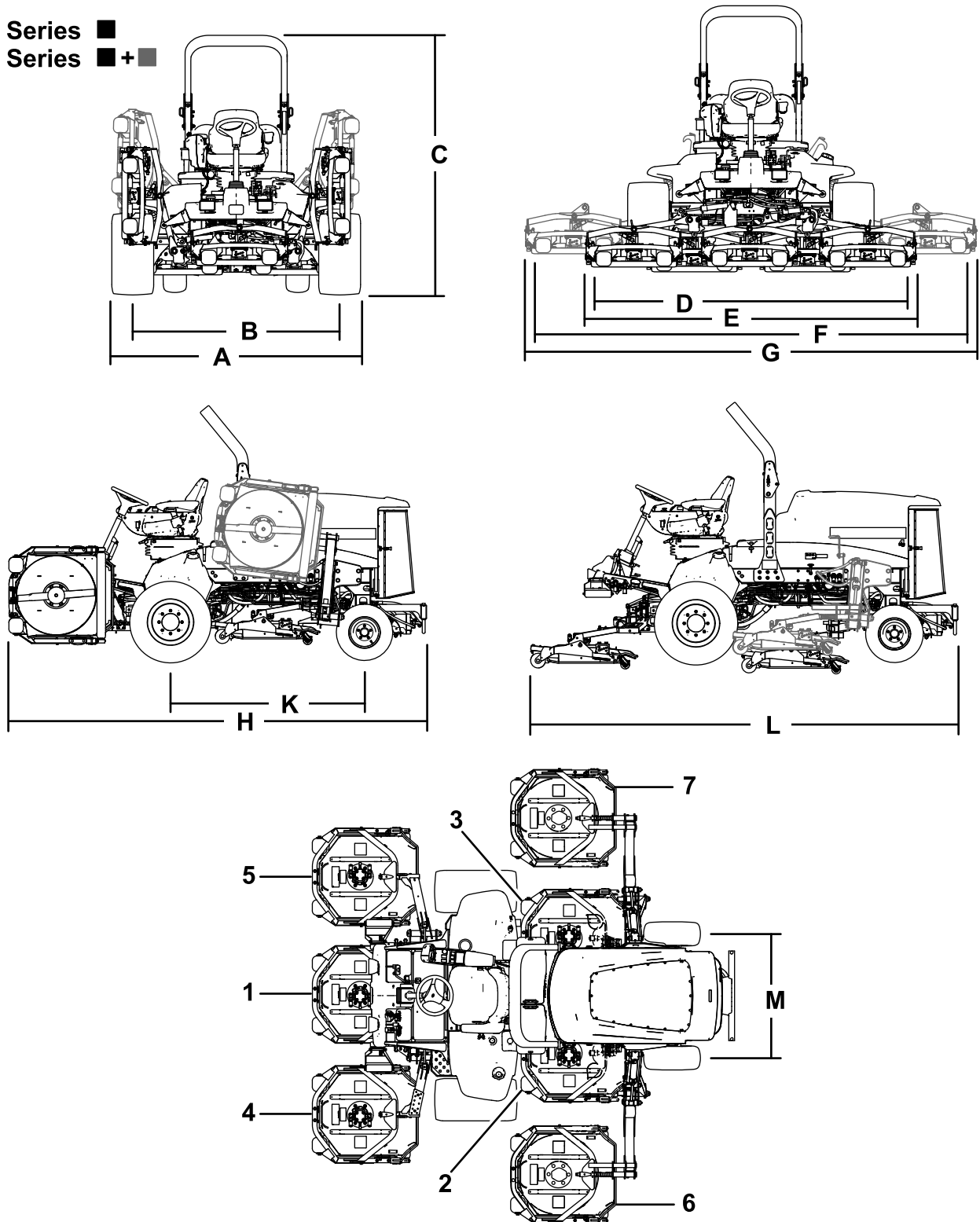

Figure 15

g322289

- | | | | |
|-------------------|-------------------|-------------------------------|-------------------------------|
| 1. Cutting unit 1 | 3. Cutting unit 3 | 5. Cutting unit 5 | 7. Cutting unit 7 (4700 only) |
| 2. Cutting unit 2 | 4. Cutting unit 4 | 6. Cutting unit 6 (4700 only) | |

Machine Specifications

Specifications Table

Description	4500-D	Figure 15 reference	4700-D	Figure 15 reference
Width of cut	280 cm (110 inches)	D	380 cm (150 inches)	F
Overall width				
Cutting units down	286 cm (113 inches)	E	391 cm (154 inches)	G
Cutting units up (transport)	224 cm (88 inches)	A	224 cm (88 inches)	A
Track width				
Front	224 cm (88 inches)	B	224 cm (88 inches)	B
Rear	141 cm (56 inches)	M	141 cm (56 inches)	M
Height with ROPS	226 cm (88.8 inches)	C	226 cm (88.8 inches)	C
Overall length				
Cutting units down	370 cm (146 inches)	H	370 cm (146 inches)	H
Cutting units up (transport)	370 cm (146 inches)	L	370 cm (146 inches)	L
Ground clearance	15 cm (6 inches)		15 cm (6 inches)	
Wheel base	171 cm (68 inches)	K	171 cm (68 inches)	K
Net weight (with cutting units and no fuel)	1937 kg (4,270 lb)		2277 kg (5,020 lb)	

Note: Specifications and design are subject to change without notice.

Cutting Unit Specifications

Specifications Table

Length	86.4 cm (34 inches)
Width	86.4 cm (34 inches)
Height	24.4 cm (9.6 inches) to carrier mount 26.7 cm (10-1/2 inches) at 3/4-inch height of cut 34.9 cm (13-3/4 inches) at 4-inch height of cut
Weight	88 kg (195 lb)

Attachments/Accessories

A selection of Toro approved attachments and accessories is available for use with the machine to enhance and expand its capabilities. Contact your Authorized Service Dealer or authorized Toro distributor or go to www.Toro.com for a list of all approved attachments and accessories.

Use only genuine Toro replacement parts and accessories. Replacement parts and accessories made by other manufacturers could be dangerous, and such use could void the product warranty.

Operation

Note: Determine the left and right sides of the machine from the normal operating position.

Before Operation

Before Operation Safety

General Safety

- Never allow children or untrained people to operate or service the machine. Local regulations may restrict the age of the operator. The owner is responsible for training all operators and mechanics.
- Become familiar with the safe operation of the equipment, operator controls, and safety signs.
- Shut off the engine, remove the key, and wait for all movement to stop before you leave the operator's position. Allow the machine to cool before adjusting, servicing, cleaning, or storing it.
- Know how to stop the machine and shut off the engine quickly.
- Check that operator-presence controls, safety switches, and guards are attached and functioning properly. Do not operate the machine unless they are functioning properly.
- Before mowing, always inspect the machine to ensure that the blades, blade bolts, and cutting assemblies are in good working condition. Replace worn or damaged blades and bolts in sets to preserve balance.
- Inspect the area where you will use the machine and remove all objects that the machine could throw.

Fuel Safety

- Use extreme care in handling fuel. It is flammable and its vapors are explosive.
- Extinguish all cigarettes, cigars, pipes, and other sources of ignition.
- Use only an approved fuel container.
- Do not remove the fuel cap or fill the fuel tank while the engine is running or hot.
- Do not add or drain fuel in an enclosed space.
- Do not store the machine or fuel container where there is an open flame, spark, or pilot light, such as on a water heater or other appliance.
- If you spill fuel, do not attempt to start the engine; avoid creating any source of ignition until the fuel vapors have dissipated.

Checking the Engine-Oil Level

Before you start the engine and use the machine, check the oil level in the engine crankcase; refer to [Checking the Engine-Oil Level \(page 50\)](#).

Checking the Cooling System

Before you start the engine and use the machine, check the cooling system; refer to [Checking the Cooling System \(page 21\)](#).

Checking the Hydraulic System

Before you start the engine and use the machine, check the hydraulic system; refer to [Checking the Hydraulic-Fluid Level \(page 65\)](#).

Draining the Water Separator

Drain water or other contaminants from the water separator; refer to [Draining Water from the Fuel/Water Separator \(page 52\)](#).

Checking the Rear Axle and Gearbox for Leaks

Check the rear axle and rear-axle gearbox for leaks; refer to [Checking the Rear Axle and Gearbox for Leaks \(page 59\)](#).

Filling the Fuel Tank

Fuel Tank Capacity

Fuel tank capacity: 83 L (22 US gallons)

Fuel Specification

Important: Use low sulphur diesel fuel.

Failure to observe the following cautions may damage the engine.

- Never use kerosene or gasoline instead of diesel fuel.
- Never mix kerosene or used engine oil with the diesel fuel.

- Never keep fuel in containers with zinc plating on the inside.
- Do not use fuel additives.

Petroleum Diesel

Cetane rating: 45 or higher

Sulfur content: Low sulfur (<500 ppm)

Fuel Table

Diesel fuel specification	Location
ASTM D975 No. 1-D S15 No. 2-D S15	USA
EN 590	European Union
ISO 8217 DMX	International
JIS K2204 Grade No. 2	Japan
KSM-2610	Korea

- Use only clean, fresh diesel fuel or biodiesel fuels.
- Purchase fuel in quantities that can be used within 180 days to ensure fuel freshness.

Use summer-grade diesel fuel (No. 2-D) at temperatures above -7°C (20°F) and winter-grade fuel (No. 1-D or No. 1-D/2-D blend) below that temperature.

Note: Use of winter-grade fuel at lower temperatures provides lower flash point and cold flow characteristics which eases starting and reduces fuel filter plugging.

Using summer-grade fuel above -7°C (20°F) contributes toward longer fuel pump life and increased power compared to winter-grade fuel.

Using Biodiesel

This machine can also use a biodiesel-blended fuel of up to B20 (20% biodiesel, 80% petrodiesel).

Sulfur content: Ultra-low sulfur (<15 ppm)

Biodiesel fuel specification: ASTM D6751 or EN14214

Blended fuel specification: ASTM D975, EN590, or JIS K2204

Important: The petroleum diesel portion must be ultra-low sulfur.

Observe the following precautions:

- Biodiesel blends may damage painted surfaces.
- Use B5 (biodiesel content of 5%) or lesser blends in cold weather.

- Monitor seals, hoses, gaskets in contact with fuel as they may degrade over time.
- Fuel filter plugging may occur for a time after you convert to biodiesel blends.
- For more information on biodiesel, contact your authorized Toro distributor.

Adding Fuel

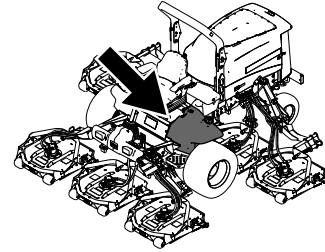

g198621

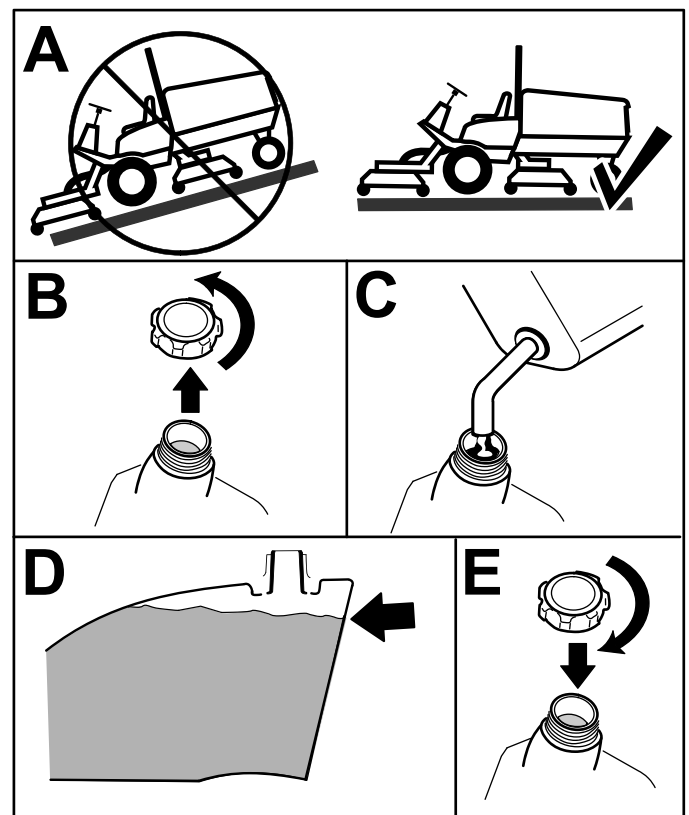

g321569

Figure 16

Fill the tank to about 6 to 13 mm (1/4 to 1/2 inch) below the top of the tank, not the filler neck, with Number 2-D diesel fuel.

Note: If possible, fill the fuel tank after each use; this will minimize possible buildup of condensation inside the fuel tank.

Checking the Tire Pressure

Service Interval: Before each use or daily

The correct air pressure in the tires is 138 kPa (20 psi).

Important: Maintain the recommended pressure in all tires to ensure a good quality of cut and proper machine performance. Do not under-inflate the tires.

Check the air pressure in all the tires before operating the machine.

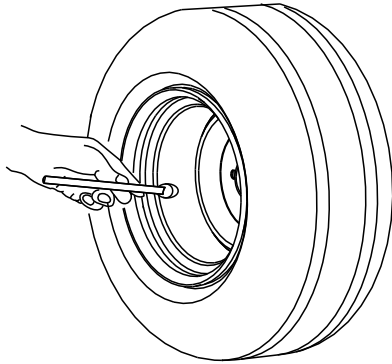

G001055

Figure 17

g001055

Checking the Torque of the Wheel Lug Nuts

Service Interval: After the first hour

After the first 10 hours

Every 200 hours

Torque the wheel lug nuts to 115 to 136 N·m (85 to 100 ft-lb) in the order shown in [Figure 18](#) and [Figure 19](#).

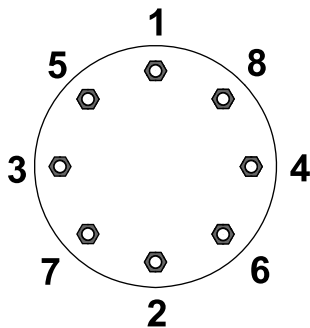

G033358

Figure 18
Front Wheels

g033358

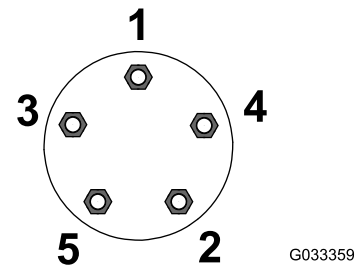

G033359

Figure 19
Rear Wheels

g033359

⚠ WARNING

Failing to maintain proper torque of the wheel lug nuts could result in personal injury.

Torque the wheel lug nuts to the proper torque value.

Adjusting the Height of Cut

Important: The rotary cutting units often cut approximately 6 mm (1/4 inch) lower than a reel cutting unit with the same bench setting. It may be necessary to set the rotary cutting-unit bench measurement at 6 mm (1/4 inch) above that of reel cutting units cutting in the same area.

Important: Access to the rear cutting units is greatly improved by removing the cutting unit from the machine.

1. Park the machine on a level surface, engage the parking brake, lower the cutting unit to the ground, shut off the engine, and remove the key.
2. Loosen the bolt securing each height-of-cut bracket to the height-of-cut plate (front and each side) as shown in [Figure 20](#).
3. Beginning with front adjustment, remove the bolt.

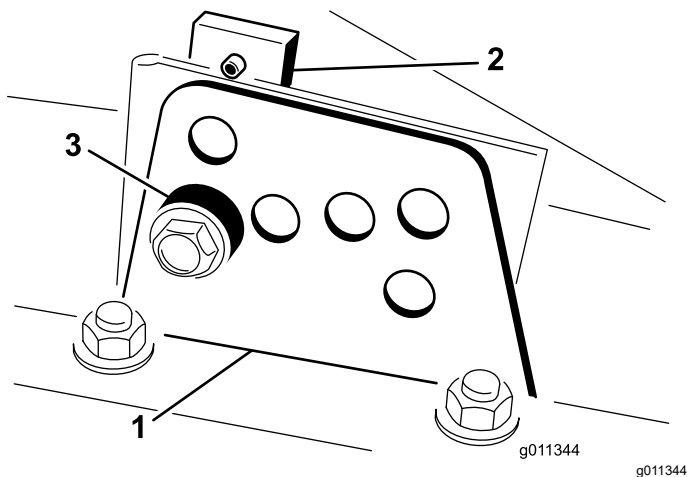

Figure 20

1. Height-of-cut bracket
2. Height-of-cut plate
3. Spacer

4. While supporting the chamber, remove the spacer (Figure 20).
5. Move the chamber to the desired height of cut and install a spacer into the designated height-of-cut hole and slot (Figure 21).

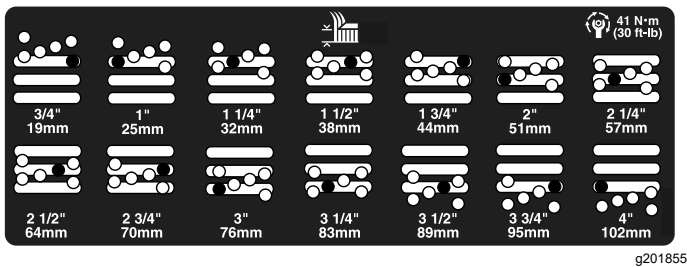

Figure 21

6. Position the tapped plate in-line with the spacer.
7. Install the bolt finger-tight.
8. Repeat steps 4 through 7 for each side adjustment.
9. Torque all 3 bolts to 41 N·m (30 ft-lb). Always tighten the front bolt first.

Note: Adjustments of more than 3.8 cm (1-1/2 inches) may require temporary assembly to an intermediate height to prevent binding (e.g., changing from 3.1 to 7 cm (1-1/4 to 2-3/4 inches) height of cut).

Checking the Interlock Switches

Service Interval: Before each use or daily

⚠ CAUTION

If safety interlock switches are disconnected or damaged, the machine could operate unexpectedly, causing personal injury.

- Do not tamper with the interlock switches.
- Check the operation of the interlock switches daily and replace any damaged switches before operating the machine.

The interlock switches are designed to shut off the machine when you rise from the seat when the traction pedal is pressed. However, you can rise from the seat while the engine is running and the traction pedal is in the NEUTRAL position. Although the engine continues to run when you disengage the PTO switch and release the traction pedal, shut off the engine before rising from the seat.

1. Park the machine on a level surface, engage the parking brake, lower the cutting units, and turn the key to the OFF position.
2. Press the traction pedal and turn the key to the ON position.

Note: If the engine cranks, there is a malfunction in the interlock system. Correct this malfunction before operating the machine.

3. Turn the key to the ON position, rise from the seat, and move the PTO switch to ON.

Note: The PTO should not engage. If the PTO engages, there is a malfunction in the interlock system. Correct this malfunction before operating the machine.

4. Engage the parking brake, turn the key to the ON position and move the traction pedal out of the NEUTRAL position.

Note: The InfoCenter displays "traction denied" and the machine should not move. If the machine does move, there is a malfunction in the interlock system. Correct this malfunction before operating the machine.

Checking the Blade-Stopping Time

Service Interval: Before each use or daily

Note: Lower the cutting units onto a clean section of turf or hard surface to avoid throwing dust and debris.

To verify this stopping time, sit in the seat and disengage the PTO. Listen for the rotating blades and record the time it takes for the blades to come to a complete stop. If it takes longer than 7 seconds, adjust the braking valve. Call your authorized Toro distributor for assistance in making this adjustment.

Selecting a Blade

Standard Combination Sail

This blade was designed to provide excellent lift and dispersion in almost any condition. If more or less lift and discharge velocity is required, consider a different blade.

Attributes: Excellent lift and dispersion in most conditions

Angled Sail (Not CE Compliant)

The blade generally performs best in lower heights of cut—1.9 to 6.4 cm (3/4 to 2-1/2 inches).

Attributes:

- Discharge remains more even at lower heights of cut.
- Discharge has less tendency to throw left and thus a cleaner look around bunkers and fairways.
- Lower power requirement at lower heights and dense turf.

High-Lift Parallel Sail (Not CE Compliant)

The blade generally performs better in the higher heights of cut—7 to 10 cm (2 to 4 inches).

Attributes:

- More lift and higher discharge velocity
- Sparse or limp turf is picked up significantly at higher heights of cut
- Wet or sticky clippings are discharged more efficiently reducing congestion in the cutting unit.
- Requires more horsepower to run
- Tends to discharge further left and can tend to windrow at lower heights of cut

⚠ WARNING

Using a high-lift blade with the mulching baffle could cause the blade to break, resulting in personal injury or death.

Do not use the high-lift blade with the mulching baffle.

Atomic Blade

This blade was designed to provide excellent leaf mulching.

Attribute: Excellent leaf mulching

Choosing Accessories

Optional Equipment Configurations

	Angle Sail Blade	High-Lift, Parallel-Sail Blade (<i>Do not use with the mulching baffle</i>)	Mulching Baffle	Roller Scraper
Grass Cutting: 1.9 to 4.4 cm (3/4 to 1-3/4 inches) height of cut	Recommended in most applications	May work well in light or sparse turf	Has been shown to improve dispersion and after-cut performance on northern grasses that are cut at least 3 times per week and less than 1/3 of the grass blade is removed. Do not use with the high-lift, parallel-sail blade	Use it whenever the rollers build up with grass or large, flat grass clumps of grass are seen. The scrapers may increase clumping in certain applications.
Grass Cutting: 5 to 6.4 cm (2 to 2-1/2 inches) height of cut	Recommended for thick or lush turf	Recommended for light or sparse turf		
Grass Cutting: 7 to 10 cm (2-3/4 to 4 inches) height of cut	May work well in lush turf	Recommended in most applications		
Leaf Mulching	Recommended for use with the mulching baffle	Not Allowed	Use with combination sail, atomic blade, or angle sail blade only	
Pros	Even discharge at lower height of cut; cleaner look around bunkers and fairways; lower power requirements	More lift and higher discharge velocity; sparse or limp turf is picked up at high height of cut; wet or sticky clippings are discharged efficiently	May improve dispersion and appearance in certain grass cutting applications; very good for leaf mulching	Reduces roller buildup in certain applications
Cons	Does not lift the grass well in high height-of-cut applications; wet or sticky grass has a tendency to build up in the chamber, leading to poor quality of cut and higher power requirements	Requires more power to run in some applications; tends to windrow at lower height of cut in lush grass; do not use with the mulching baffle	Grass will build up in the chamber if you attempt to remove too much grass with the baffle in place	

Using the InfoCenter LCD Display

The InfoCenter LCD display shows information about your machine, such as the operating status, various diagnostics and other information about the machine (Figure 22). There is a splash screen and main information screen of the InfoCenter. You can switch between the splash screen and main information screen at any time by pressing any of the InfoCenter buttons and then selecting the appropriate directional arrow.

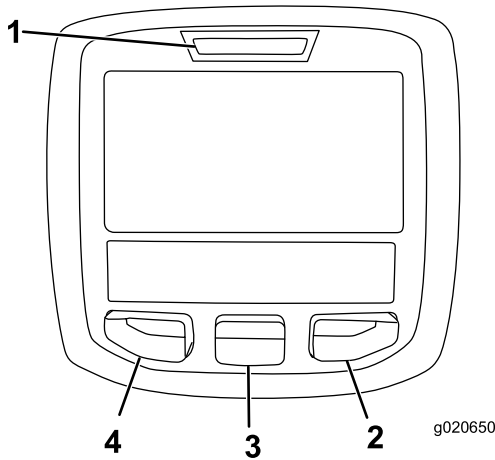

Figure 22

- 1. Indicator light
- 2. Right button
- 3. Middle button
- 4. Left button











- Left Button, Menu Access/Back Button—press this button to access the InfoCenter menus. You can use it to exit any menu that you are currently using.
- Middle Button—use this button to scroll down menus.
- Right Button—use this button to open a menu where a right arrow indicates additional content.
- Beeper—activated when lowering the cutting units or for advisories and faults.

Note: The purpose of each button may change depending on what is required at the time. Each button is labeled with an icon displaying its current function.





InfoCenter Icon Description

	Indicates when scheduled service should be performed
	Hours remaining until service
	Reset the service hours
	The status of the engine rpm
	Info icon
	Maximum traction speed setting
	The fan is reversed
	The air-intake heater is active
	Raise the left cutting unit.
	Raise the center cutting unit
	Raise the right cutting unit
	The operator must sit in the seat
	The parking brake is engaged
	The mode is high
	Neutral
	The mode is low
	Coolant temperature (°C or °F)
	Temperature (hot)
	Traction or Traction Pedal
	Not allowed
	Start the engine.
	The PTO is on.
	The cruise control is on.
	Shut off the engine

InfoCenter Icon Description (cont'd.)

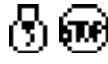
	Engine
	Key switch
	Cutting units are lowering
	Cutting units are raising
PIN	PIN code
	Hydraulic fluid temperature
CAN	CAN bus
	InfoCenter
Bad	Bad or failed
Ctr	Center
Rht	Right
Left	Left
	Bulb
OUT	Output of TEC controller or control wire in harness
HI	Over the allowed range
LO	Under the allowed range
HI , LO	Out of range
	Switch
	Operator must release switch
	Operator should change to indicated state
Symbols are often combined to form sentences. Some examples are shown below	
	Operator should put machine in neutral

InfoCenter Icon Description (cont'd.)

	Engine start is denied
	Engine shutdown
	Engine coolant is too hot
	Hydraulic fluid is too hot
	Sit down or engage parking brake

 Accessible only by entering PIN

Using the Menus

To access the InfoCenter menu system, press the menu access button while at the main screen. This brings you to the main menu. Refer to the following tables for an overview of the options available from the menus:

Main Menu	
Menu Item	Description
Faults	Contains a list of the recent machine faults; refer to the <i>Service Manual</i> for more information.
Service	Contains information on the machine such as hours of use and other similar numbers
Diagnostics	Lists various states that the machine currently has; you can use this to troubleshoot certain issues as it quickly tells you which machine controls are on and which are off.
Settings	Allows you to customize and modify configuration variables on the InfoCenter display
About	Lists the model number, serial number, and software version of your machine

Service	
Menu Item	Description
Hours	Lists the total number of hours that the machine, engine, and fan have been on, as well as the number of hours the machine has been transported and overheated
Counts	Lists the number of starts, cutting unit/PTO cycles, and fan reversals the machine has experienced

Diagnostics	
Menu Item	Description
Left Cutting Unit	Refer to the <i>Service Manual</i> or your authorized Toro distributor for more information on the Engine Run menu and the information contained there.
Center Cutting Unit	
Right Cutting Unit	
Traction	
HI/LO Range	
PTO	
Engine	
Cruise	

Settings	
Menu Item	Description
Units	Controls the units used on the InfoCenter (English or Metric)
Language	Controls the language used on the InfoCenter*
LCD Backlight	Controls the brightness of the LCD display
LCD Contrast	Controls the contrast of the LCD display
Protected Menu	Allows a person authorized by your company with the PIN code to access protected menus.
Protect Settings	Allows the ability to change the settings in the protected settings
Acceleration	Low, Medium, and High settings control how quickly the traction speed reacts when you move the traction pedal.
Mow Speed	Controls the maximum speed while in mow (low range)
Trans. Speed	Controls the maximum speed while in transport (high range)
Smart Power	Turns Smart Power on and off

Counterbalance	Controls the amount of counterbalance applied by the cutting units
Turnaround	Turns Turnaround on and off

*Only operator-faced text is translated. Faults, Service, and Diagnostics screens are service-faced. Titles are in the selected language, but menu items are in English.

Protected under Protected Menus—accessible only by entering PIN

About	
Menu Item	Description
Model	Lists the model number of the machine
SN	Lists the serial number of the machine
S/W Rev	Lists the software revision of the primary controller

Protected Menus

There are 6 operating configuration settings that are adjustable within the Settings Menu of the InfoCenter: auto idle, maximum mowing ground speed, maximum transport ground speed, Smart Power, cutting unit counterbalance, and Turnaround. These settings are in the Protected Menu.

Accessing Protected Menus

Note: The factory default PIN code for you machine is either 0000 or 1234.

If you changed the PIN code and forgot the code, contact your authorized Toro distributor for assistance.

1. From the MAIN MENU, use the center button to scroll down to the SETTINGS MENU and press the right button (Figure 23).

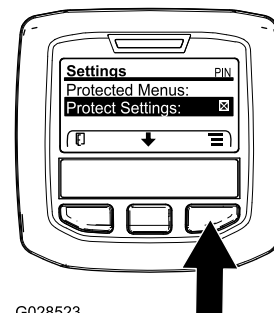

G028523

g028523

Figure 23

2. In the SETTINGS MENU, use the center button to scroll down to the PROTECTED MENU and press the right button (Figure 24A).

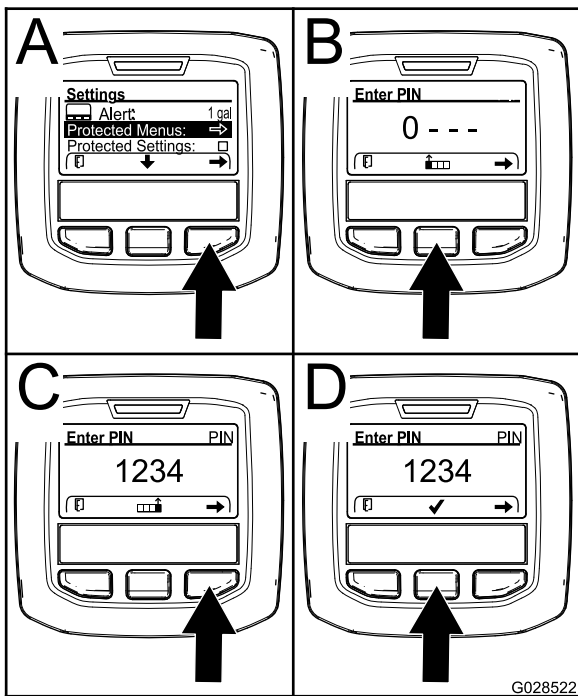

Figure 24

G028522
g028522

- To enter the PIN code, press the center button until the correct first digit appears, then press the right button to move on to the next digit (Figure 24B and Figure 24C). Repeat this step until the last digit is entered and press the right button once more.
- Press the middle button to enter the PIN code (Figure 24D).

Wait until the red indicator light of the InfoCenter illuminates.

Note: If the InfoCenter accepts the PIN code and the protected menu is unlocked, the word “PIN” displays in the upper right corner of the screen.

Note: Rotate the key switch to the OFF position and then to the ON position locks the protected menu.

You can view and change the settings in the Protected Menu. Once you access the Protected Menu, scroll down to Protect Settings option. Use the right button to change the setting. Setting the Protect Settings to OFF allows you to view and change the settings in the Protected Menu without entering the PIN code. Setting the Protect Settings to ON hides the protected options and requires you to enter the PIN code to change the setting in the Protected Menu. After you set the PIN code, rotate the key switch OFF and back to the ON position to enable and save this feature.

Viewing and Changing the Protected Menu Settings

- In the Protected Menu, scroll down to Protect Settings.
- To view and change the settings without entering a PIN code, use the right button to change the Protect Settings to OFF.
- To view and change the settings with a PIN code, use the left button to select ON, set the PIN code, and turn the key to the OFF position and then to the ON position.

Setting the Maximum Allowed Mow Speed

The selected setting is displayed as an X on the traction-speed bar graph along with the cruise control and pedal stop settings. An X in a bar shows you that the maximum speed is limited by the supervisor (Figure 27 or Figure 29).

Note: This setting is retained in memory and applied to the traction speed until you change it.

- In the Settings Menu, scroll down to Mow Speed and press the right button.
- Use the right button to increase the maximum mow speed in 5% increments between 50% and 100%.
- Use the center button to decrease the maximum mow speed in 5% increments between 50% and 100%.
- Press the left button to exit.

Setting the Maximum Allowed Transport Speed

The selected setting is displayed as an X on the traction-speed bar graph along with the cruise control and pedal stop settings. An X in a bar shows you that the maximum speed is limited by the supervisor (Figure 27 or Figure 29).

Note: This setting is retained in memory and applied to the traction speed until you change it.

- In the Settings Menu, scroll down to Transport Speed and press the right button.
- Use the right button to increase the maximum transport speed in 5% increments between 50% and 100%.
- Use the center button to decrease the maximum transport speed in 5% increments between 50% and 100%.
- Press the left button to exit.

Turning the Smart Power ON/OFF

1. In the settings menu, scroll down to Smart Power.
2. Press the right button to switch between ON and OFF.
3. Press the left button to exit.

Setting the Counterbalance

1. In the Settings Menu, scroll down to Counterbalance.
2. Press the right button to select counterbalance and change between the LOW, MEDIUM, and HIGH settings.

Actuating Turnaround ON/OFF

1. In the Settings Menu, scroll down to Turnaround.
2. Press the right button to switch between ON and OFF.
3. Press the left button to exit.

Setting the Acceleration Mode

1. In the Settings Menu, scroll down to Acceleration.
2. Press the right button to switch between LOW, MEDIUM, and HIGH.
3. Press the left button to exit.

Viewing the Fuel Consumption Rate

You can view the average fuel consumption rate for the lifetime of the machine in the Service Menu.

Setting the Service Due Timer

This resets the service due hours after a scheduled maintenance item is preformed.

1. In the Service Menu, navigate to the Hours Menu.
2. Scroll down to the Reset Service Due option and press the right button.
3. Press the left button to exit.

During Operation

During Operation Safety

General Safety

- The owner/operator can prevent and is responsible for accidents that may cause personal injury or property damage.
- Wear appropriate clothing, including eye protection; long pants; substantial, slip-resistant footwear; and hearing protection. Tie back long hair and do not wear loose clothing or loose jewelry.
- Do not operate the machine while ill, tired, or under the influence of alcohol or drugs.
- Use your full attention while operating the machine. Do not engage in any activity that causes distractions; otherwise, injury or property damage may occur.
- Before you start the engine, ensure that all drives are in neutral, the parking brake is engaged, and you are in the operating position.
- Do not carry passengers on the machine and keep bystanders and children out of the operating area.
- Operate the machine only in good visibility to avoid holes or hidden hazards.
- Avoid mowing on wet grass. Reduced traction could cause the machine to slide.
- Keep your hands and feet away from rotating parts. Keep clear of the discharge opening.
- Look behind and down before backing up to be sure of a clear path.
- Use care when approaching blind corners, shrubs, trees, or other objects that may obscure your vision.
- Stop the blades whenever you are not mowing.
- Stop the machine, remove the key, and wait for all moving parts to stop before inspecting the attachment after striking an object or if there is an abnormal vibration in the machine. Make all necessary repairs before resuming operation.
- Slow down and use caution when making turns and crossing roads and sidewalks with the machine. Always yield the right-of-way.
- Disengage the drive to the cutting unit, shut off the engine, remove the key, and wait for all movement to stop before adjusting the height of cut (unless you can adjust it from the operating position).
- Operate the engine only in well-ventilated areas. Exhaust gases contain carbon monoxide, which is lethal if inhaled.
- Never leave a running machine unattended.

- Before you leave the operator's position, do the following:
 - Park the machine on a level surface.
 - Disengage the power takeoff and lower the attachments.
 - Engage the parking brake.
 - Shut off the engine and remove the key.
 - Wait for all movement to stop.
- Operate the machine only in good visibility. Do not operate the machine when there is the risk of lightning.
- Do not use the machine as a towing vehicle.
- Use accessories, attachments, and replacement parts approved by Toro only.
- Lower a folding roll bar temporarily only when necessary. Do not wear the seat belt when the roll bar is folded down.
- Be aware that there is no rollover protection when a folded roll bar is in the down position.
- Check the area that you will be mowing and never fold down a folding roll bar in areas where there are slopes, drop-offs, or water.

Rollover Protection System (ROPS) Safety

- The ROPS is an integral and effective safety device.
- Do not remove any of the ROPS components from the machine.
- Ensure that the seat belt is attached to the machine.
- Pull the belt strap over your lap and connect the belt to the buckle on the other side of the seat.
- To disconnect the seat belt, hold the belt, press the buckle button to release the belt, and guide the belt into the auto-retract opening. Ensure that you can release the belt quickly in an emergency.
- Check carefully for overhead obstructions and do not contact them.
- Keep the ROPS in safe operating condition by thoroughly inspecting it periodically for damage and keeping all the mounting fasteners tight.
- Replace damaged ROPS components. Do not repair or alter them.

Additional ROPS Safety for Machines with a Cab or a Fixed Roll Bar

- A cab installed by Toro is a roll bar.
- Always wear your seat belt.

Additional ROPS Safety for Machines with a Foldable Roll Bar

- Keep a folding roll bar in the raised and locked position, and wear your seat belt when operating the machine with the roll bar in the raised position.

Slope Safety

- Slopes are a major factor related to loss of control and rollover accidents, which can result in severe injury or death. You are responsible for safe slope operation. Operating the machine on any slope requires extra caution.
- Evaluate the site conditions to determine if the slope is safe for machine operation, including surveying the site. Always use common sense and good judgment when performing this survey.
- Review the slope instructions listed below for operating the machine on slopes and to determine whether you can operate the machine in the conditions on that day and at that site. Changes in the terrain can result in a change in slope operation for the machine.
- Avoid starting, stopping, or turning the machine on slopes. Avoid making sudden changes in speed or direction. Make turns slowly and gradually.
- Do not operate a machine under any conditions where traction, steering, or stability is in question.
- Remove or mark obstructions such as ditches, holes, ruts, bumps, rocks, or other hidden hazards. Tall grass can hide obstructions. Uneven terrain could overturn the machine.
- Be aware that operating the machine on wet grass, across slopes, or downhill may cause the machine to lose traction. Loss of traction to the drive wheels may result in sliding and a loss of braking and steering.
- Use extreme caution when operating the machine near drop-offs, ditches, embankments, water hazards, or other hazards. The machine could suddenly roll over if a wheel goes over the edge or the edge caves in. Establish a safety area between the machine and any hazard.
- Identify hazards at the base of the slope. If there are hazards, mow the slope with a pedestrian-controlled machine.
- If possible, keep the cutting unit(s) lowered to the ground while operating on slopes. Raising the cutting unit(s) while operating on slopes can cause the machine to become unstable.
- Use extreme caution with grass-collection systems or other attachments. These can change the stability of the machine and cause a loss of control.

Understanding the Operating Characteristics of the Machine

- This machine has an automotive-style throttle that is controlled by the traction pedal.
- This machine does not have a separate throttle switch or throttle lever.
- When you remove your foot from the traction pedal, the machine dynamically brakes to a stop.
- The pedal controls are optimized to provide a reactive yet stable response, allowing you to maintain consistent control over rough terrain, while still allowing for quick, smooth braking.
- While transporting, the traction pedal will operate similar to a car and change the engine and traction speed dependent on the traction pedal position.
- When mowing, the engine speed will automatically raise to high idle.
- If the engine is at low idle, performing a function like lifting the cutting units or pressing the traction pedal raises the engine speed to a minimum working speed, providing enough power to efficiently perform the function.
- Limit the machine idle time as recommended for diesel particulate filter (DPF) regeneration. Shut off the machine to prevent extended idling time.
- The maximum speeds set in the PIN protected menu settings are set by the supervisor to limit the machine's maximum traction speed.
- The achievable traction pedal use, cruise control, and pedal stop traction speeds are all limited by the maximum speeds set in the PIN protected menu.

Operating the Machine

- When you start the engine and the hydraulic fluid temperature is low, the engine speed automatically increases to optimize operation and warms up the machine. The engine speed automatically returns to low idle after the hydraulic fluid temperature is in a normal operating range.
- Under normal operating conditions, this machine is intended to operate in the H/L AUTO position on the speed range switch (Figure 25). This position allows the machine to automatically switch between low and high speed ranges, depending on whether the machine is being used for mowing or transporting.
- When you select the Low position on the speed range switch (Figure 25), the machine will always

operate in low speed range. This setting is preferable for operation in a shop area, loading or unloading from a trailer, climbing steep inclines, or any other operation where the higher traction speeds of the high speed range is not desired.

- If an obstacle is in the way, lift the cutting units to mow around it.
- When transporting the machine between work areas, engage the AUTO Hi/LOW range, shut off the PTO, and raise the cutting units to the fully upward position. This allows the traction pedal to operate like a car.
- Always drive slowly in rough areas.

Practice Operating the Machine

- To get familiar with the features of the machine, practice operating the machine.
 - Lift the cutting units, disengage the parking brake, press the forward traction pedal, and carefully drive to an open area.
 - Practice driving the machine, because it has a hydrostatic transmission and its features can differ from other turf-maintenance machines.
 - Practice moving forward and reverse, and starting and stopping the machine. To stop the machine, remove your foot from the traction pedal and let it return to NEUTRAL.
- Note:** When going downhill in the machine, you may need to use the reverse pedal to stop.
- Remove your foot from the traction pedal and press down on the brake pedals to stop quickly.
 - Practice driving around obstacles with the cutting units up and down. Be careful when driving between narrow objects so that you do not damage the machine or cutting units.

Using the High and Low Speed Range Switch

This machine is equipped with 2 traction speed ranges; low and high. The speed range switch allows you to select the following positions ([Figure 25](#)):

- **High/Low Auto range:**

Selecting the H/L AUTO position allows the machine to automatically select between the low and high speed ranges. The H/L AUTO position is comparable to selecting D (drive) in your car with an automatic transmission.

Note: To prevent potential turf damage, the machine will only shift between low and high range when the traction pedal is in NEUTRAL position and the wheels have stopped moving.

Note: The cutting units cannot be lowered from the transport position while you drive the machine in the high speed range.

- When H/L AUTO position is selected and the cutting units are lowered for mowing, the speed range is limited to the low speed range.
- To get to high speed range, select the H/L AUTO position on the speed range switch, disengage the PTO, and fully raise the cutting units.
- When H/L AUTO position is selected, the machine will automatically switch between high and low traction ranges based on the position of the cutting units and/or the position of the PTO switch.

- **Low range:**

Selecting the LOW position on the switch keeps the machine in the low speed range at all times. The LOW position is comparable to selecting 2, 1 OR L in your car with an automatic transmission.

- When the LOW position is selected, the machine only operates in low range.
- Use the Low position when loading the machine on a trailer or navigating tight areas like a shop.

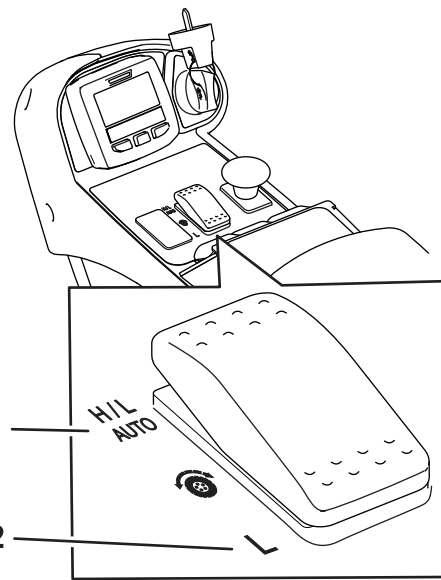

Figure 25

Speed Range Switch

g321487

1. H/L AUTO position 2. Low position

Using the Traction Pedal

This pedal controls the forward and reverse speed of the machine and the dynamic braking when you return it to neutral.

- The traction pedal is an automotive-style throttle—the engine speed and the machine speed respond to the pedal movement.
- While transporting, the traction pedal will operate similar to a car and change the engine and traction speed dependent on the traction pedal position.
- While mowing, the engine automatically raises to high idle to optimize mowing performance, and the traction pedal only controls traction speed.
- The further you push the pedal forward or reverse, the faster the machine moves.
- To control the machine to a smooth stop while transporting or mowing, use your foot to return the traction pedal to neutral at your desired rate.
- To engage maximum braking, remove your foot from the traction pedal, allowing it to return to neutral. The machine dynamically brakes to a stop.

This traction system allows you to customize the acceleration settings for operator comfort and course conditions. Refer to [Understanding the Acceleration Mode \(page 37\)](#) for changing the settings.

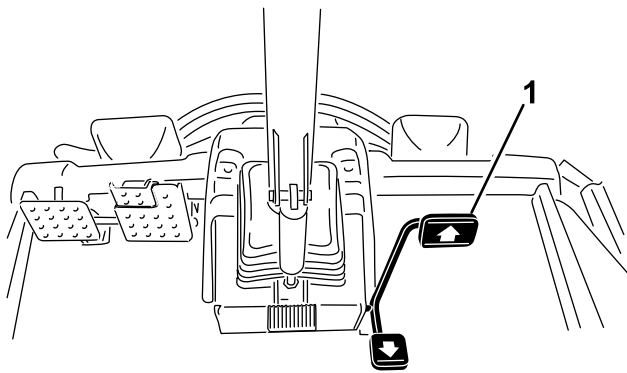

Figure 26

g321522

1. Traction pedal

Setting the Maximum Traction Speed (Pedal Stop)

This feature allows the ability to set the maximum speed of the machine when you push the pedal fully forward (Figure 26). You can set a separate speed for the low range and high range (Figure 25).

- To access this feature, select the InfoCenter middle button from the main screen (Figure 24).

Note: This feature reverts back to the machine settings when the key is switched off.

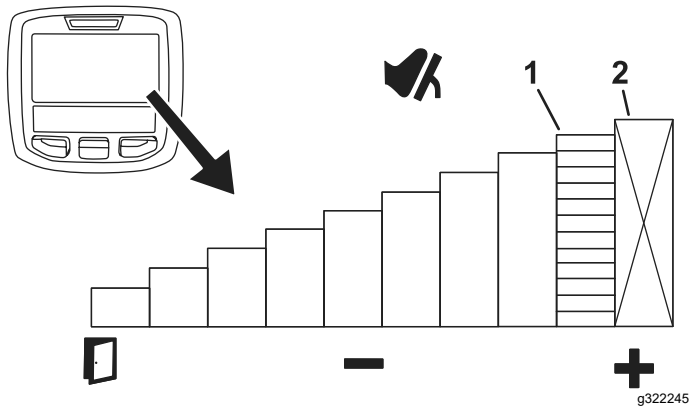

Figure 27

g322245

1. Indicates the maximum traction speed (pedal stop)
2. This speed is locked out under the protected PIN menu.

- This feature allows you to customize the speed settings for your comfort level, or to customize the speed settings to fit the application.
 - You can use this feature to limit the maximum traction speed to 75% while mowing in an area with many trees.
 - If you adjust the maximum traction speed to 75%, the maximum speed of the machine

is limited from 0 to 75% and matched to the full stroke of the traction pedal. This setting increases the traction pedal resolution, resulting in improved control. How far you move the traction pedal changes how much the machine's speed changes.

Using the Brake Pedals

Important: In emergency braking situations, remove your foot from the traction pedal and then press the brake pedals.

In the low speed range only, you can use the brakes individually for turning or to improve traction. Perform the following when using the brakes individually:

- Disconnect the pedal-locking latch (Figure 28).
- For turning assist, press the corresponding brake pedal to the side you are turning. This allows a tighter turning radius.

Note: Use the individual brakes carefully, especially on soft or wet grass, because the turf may be torn accidentally.

- For traction assist, apply light pressure to the brake pedal corresponding to the front tire that is slipping. For example, in some slope conditions, the uphill wheel slips and loses traction. If this situation occurs, press the uphill brake pedal gradually and intermittently until the uphill wheel stops slipping. This action increases the traction on the downhill wheel.

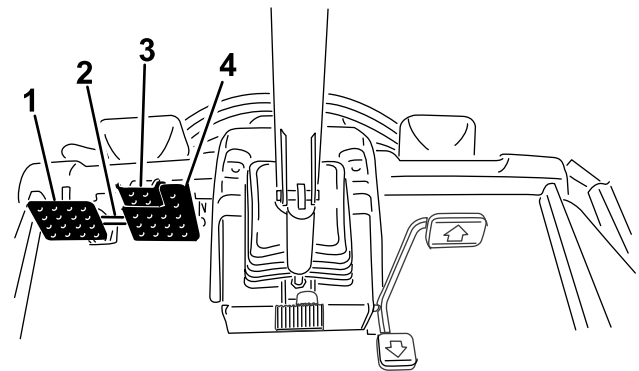

Figure 28

g321521

1. Left brake pedal
2. Pedal-locking latch
3. Parking-brake pedal
4. Right brake pedal

Operating the Cruise Control

Setting the Cruise Control

The cruise-control switch locks in the cruise control to maintain the desired ground speed. Pressing the rear of the switch turns the cruise control off, the middle position of the switch enables the cruise-control function, and the front of the switch sets the desired ground speed.

After the cruise control switch is enabled and the speed is set (Figure 29), use the InfoCenter to adjust the speed setting of the cruise control (Figure 22 and Figure 30).

To disengage the cruise control use the following:

- When in high speed range, press the reverse traction pedal, press the service brakes, or press the cruise control switch to the OFF position.
- When in low speed range, press the reverse traction pedal, press the service brakes, shut off the PTO switch, or press the cruise control switch to the OFF position.

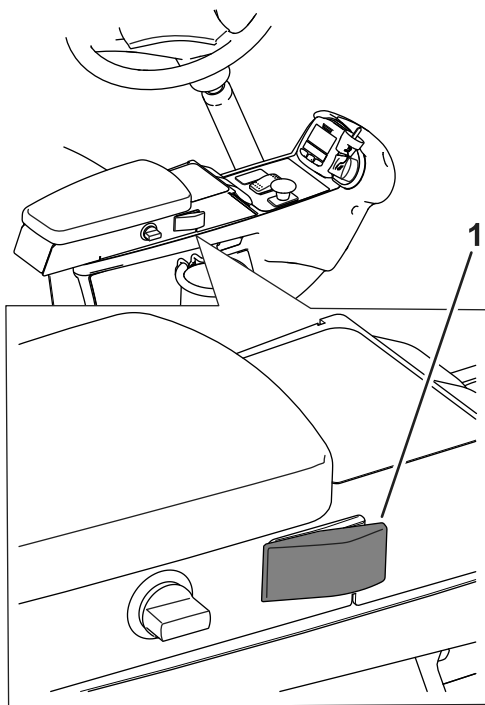

Figure 29

g321488

1. Cruise-control switch

Adjusting the Cruise Control Speed

After the cruise control switch is enabled on the console Figure 29, use the InfoCenter to adjust the speed setting of the cruise control (Figure 30).

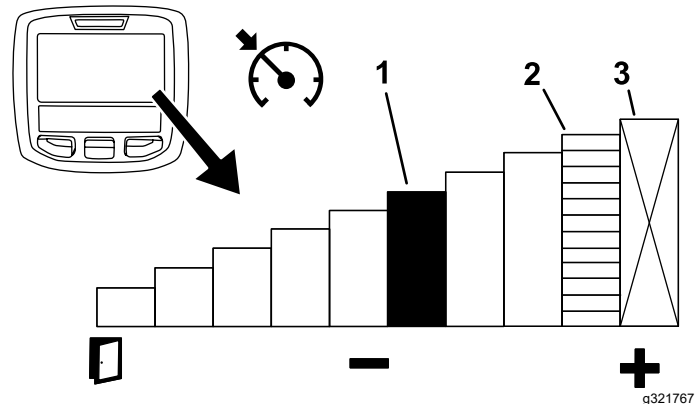

Figure 30

1. Indicates the cruise control speed
2. Indicates the maximum traction speed (pedal stop)
3. This speed is locked out under the protected PIN menu.

Tips for Using the Cruise Control

- Set a cruising speed for long distances without many obstacles.
- On rough terrain, use the InfoCenter to control the speed.
- Use the cruise control for turnarounds as follows:
 1. Set the cruise control to slower speed that you're comfortable and safe at while turning around.
 2. Press the traction pedal to increase the speed for mowing during the mowing pass.
 3. Take your foot off the pedal when turning around for the next mowing pass.
 4. The machine will slow down to the low cruise control setting, allowing you to make an efficient turnaround at a constant speed.
 5. After turning around, use the traction pedal to increase the machine speed back up for the next mowing pass.

Understanding the Acceleration Mode

This setting determines how quickly the machine changes traction speed, and effects the deceleration of the machine in the low speed range. Enter the protect menus in the InfoCenter to change the acceleration mode. The acceleration mode has the following 3 positions:

- Low—low acceleration and deceleration
- Medium—medium acceleration and deceleration
- High—highest acceleration and deceleration

Understanding the Turnaround Mode

The turnaround mode allows you convenient, 1-touch control to raise the cutting units above the turf while temporarily stopping the blades, allowing you to focus on driving the machine at the end of a mowing pass, or while navigating other obstacles.

Note: The turnaround mode is a feature in the protected settings.

- When the turnaround mode is set to the ON position, you momentarily press the lift switch rearward (Figure 11) to automatically raise all cutting units from the float position to a preset height, automatically disengaging the PTO. To resume mowing, press the lift switch forward. All the cutting units lower, and the PTO starts again.
- When the turnaround mode is set to the OFF position, you manually raise the cutting units from the float position by pressing and holding all lift switches rearward until the cutting units raise to the desired height. For Groundsmaster 4700 machines, press all 3 lift switches to raise all 7 cutting units (Figure 11). The PTO does not disengage until the cutting units raise to the same preset height to which the cutting units raise when the turnaround-mode is set to ON.

Note: By default, the turnaround mode is ON.

Understanding Counterbalance

The counterbalance system maintains hydraulic back pressure on the cutting-unit lift cylinders. The counterbalance system monitors the real-time traction pressure, dynamically changing the lift-cylinder back pressure to optimize traction capability and after-cut appearance. The counterbalance pressure has been set at the factory to an optimal balance of after-cut

appearance and traction capability in most turf conditions. Decreasing the counterbalance setting can produce a more stable cutting unit but can decrease the traction capability. Increasing the counterbalance setting can increase the traction capability, but may result in a poor after-cut appearance; refer to [Accessing Protected Menus \(page 29\)](#).

The customizable counterbalance setting controls are as follows:

- Low—the most amount of weight on cutting units and the lowest weight on the drive wheels
- Medium—medium weight on cutting units and the drive wheels
- High—the least amount of weight on cutting units and the highest weight on machine drive wheels

Understanding Toro Smart Power™

With Smart Power, the operator does not have to listen to the engine speed in heavy load conditions. Smart Power prevents the engine from bogging down in heavy cutting conditions by automatically controlling the machine speed and optimizing cutting performance.

Note: By default, the Smart Power feature is ON.

Starting the Engine

Important: Bleed the fuel system if any of the following have occurred:

- The engine has shut off due to lack of fuel.
 - Maintenance has been performed upon the fuel system components.
1. Remove your foot from the traction pedal and ensure that it is in NEUTRAL. Ensure that the parking brake is engaged.
 2. Turn the key to the RUN position. The glow indicator should illuminate.
 3. When the glow indicator dims, turn the key to the START position.

Important: Do not run the starter motor more than 15 seconds at a time or premature starter failure may result. If the engine fails to start after 15 seconds, turn the key to the OFF position, check the controls and procedures, wait 15 additional seconds, and repeat the starting procedure.

4. Release the key immediately when the engine starts and allow it to return to the RUN position.

When the temperature is less than -7°C (20°F), the starter motor can be run for 30 seconds on then 60 seconds off for 2 attempts.

Important: Shut off the engine and allow the engine to cool before you check for oil leaks, loose parts, or other malfunctions.

Shutting Off the Engine

Important: Allow the engine to idle for 5 minutes before shutting it off after a full-load operation. This allows the turbocharger to cool down before shutting off the engine. Failure to do so may lead to premature turbocharger failure.

Note: Lower the cutting units to the ground whenever the machine is parked. This relieves the hydraulic load from the system, prevents wear on system parts and also prevents accidental lowering of the cutting units.

1. Move the PTO switch to the OFF position.
2. Engage the parking brake.
3. Rotate the ignition key to the OFF position.
4. Remove the key to prevent accidental starting.

Cutting Grass with the Machine

Note: Cutting grass at a rate that loads the engine promotes DPF regeneration.

1. Disengage the brake, disengage the PTO, and raise the cutting units.
2. Select the H/L AUTO or LOW position with the speed range switch. Refer to Using the High and Low Speed Range Switch.

Note: When the H/L AUTO position is selected and the cutting units are raised, the machine will automatically select the high speed range.

3. Using the traction pedal like an accelerator pedal on a car, drive the machine to the job site.
4. Align the machine outside the cutting area for the first cutting pass.
5. Lower the cutting units with the rocker switch or switches.
6. Tap the lift switch (GM4500) or middle-lift switch (GM4700) rearward to lift the cutting units to the turnaround position.

Note: The turnaround position is only available if it is activated under the protected menus in the InfoCenter. Tapping the rocker switch without holding it raises the cutting units to the turn around position and stops the rotation of the blades until the cutting units are lowered.

7. Pull the PTO switch to engage the cutting units.

Note: The engine speed automatically rises to high idle when you lower the cutting units and activate the PTO switch.

8. Using the traction pedal, approach the mowing area slowly and lower the cutting units with the rocker switch once the front cutting units are over the mowing area.

Note: Practice to ensure the cutting units do not lower early or mow an unintended area.

9. Begin mowing the area.
10. When you complete the mowing pass, tap the lift switch (GM4500) or middle-lift switch (GM4700) rearward to lift the cutting units to the turn around position.
11. Perform a tear-shaped turn to quickly line up for your next pass.
12. Press the lift switch (GM4500) or middle-lift switch (GM4700) down to automatically lower the cutting units from the turnaround position and continue mowing.

Operating the Engine-Cooling Fan

The engine cooling fan is normally controlled by the machine. The machine has the ability to reverse the fan to blow debris off the rear screen. Under normal operating conditions, the machine controls the fan speed and direction based on coolant and hydraulic-fluid temperature, and the fan automatically reverses direction to blow debris off the rear screen.

You can manually reverse the fan by pressing the 2 outer buttons of the InfoCenter (Figure 31) for 2 seconds—the fan completes a manually initiated reverse cycle. Reverse the fan when the rear screen is clogged or prior to moving the machine into the shop or a storage area.

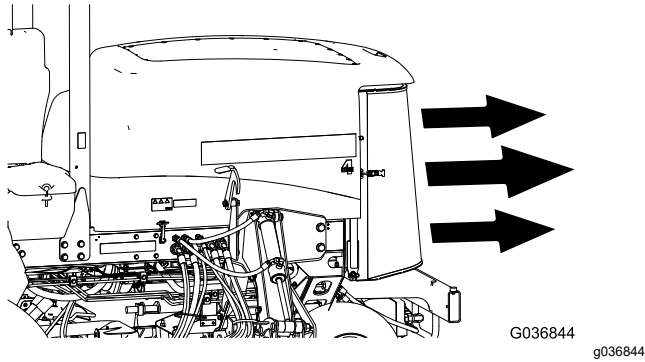
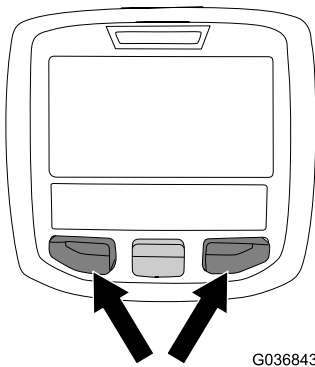

Figure 31

when you maintain turf on a regular schedule to avoid removing more than 25 mm (1 inch) of growth per cutting. When you cut too much growth with the mulching baffles installed, the after-cut appearance may deteriorate and the observed power to cut the turf increases. The mulching baffles also perform well for shredding leaves in the fall.

Selecting the Proper Height-of-Cut Setting to Suit Conditions

Remove no more than approximately 25 mm (1 inch), or 1/3 of the grass blade when cutting. In exceptionally lush and dense grass, you may need to raise your height-of-cut setting.

Mowing with Sharp Blades

A sharp blade cuts cleanly and without tearing or shredding the grass blades like a dull blade. Tearing and shredding causes the grass to turn brown at the edges, which impairs growth and increases susceptibility to diseases. Ensure that the blade is in good condition and that there is a full sail; refer to [Servicing the Blade Plane \(page 70\)](#).

Operating Tips

Changing Mowing Patterns

Change mowing patterns often to minimize a poor after-cut appearance from repeatedly mowing in the same direction.

Resolving After-Cut Appearance

Refer to the *After-cut Appearance Troubleshooting Guide* available at www.Toro.com.

Using Proper Mowing Techniques

- To begin cutting, engage the cutting units, then approach the mowing area slowly. Once the front cutting units are over the mowing area, lower the cutting units.
- To achieve the professional straight-line cut and striping that is desirable for some applications, find a tree or other object in the distance and drive straight toward it.
- As soon as the front cutting units reach the edge of the mowing area, lift the cutting units, and perform a teardrop-shaped turn to quickly line up for your next pass.
- Bolt-in mulching baffles are available for the cutting units. The mulching baffles perform well

Checking the Condition of the Cutting Unit

Ensure that the cutting chambers are in good condition. Straighten any bends in the chamber components to ensure correct blade tip/chamber clearance. Ensure all rollers and pivoting joints do not have play in them to prevent turf damage or poor after cut appearance.

Maintaining the Machine after Mowing

After mowing, thoroughly wash the machine with a garden hose with no nozzle to avoid contamination and damage to the seals and bearings caused by excessive water pressure. Ensure that the radiator and oil cooler are kept free of dirt or grass clippings. After cleaning, inspect the machine for possible hydraulic-fluid leaks, damage, or wear to the hydraulic and mechanical components, and check the cutting-unit blades for sharpness.

After Operation

General Safety

- Shut off the engine, remove the key, and wait for all movement to stop before you leave the operator's position. Allow the machine to cool before adjusting, servicing, cleaning, or storing it.
- Clean grass and debris from the cutting units, mufflers, and engine compartment to help prevent fires. Clean up oil or fuel spills.
- If the cutting units are in the transport position, use the positive mechanical lock (if available) before you leave the machine unattended.
- Allow the engine to cool before storing the machine in any enclosure.
- Remove the key and shut off the fuel (if equipped) before storing or hauling the machine.
- Never store the machine or fuel container where there is an open flame, spark, or pilot light, such as on a water heater or on other appliances.
- Maintain and clean the seat belt(s) as necessary

Using the Cutting-Unit Storage Lanyard

Use the cutting-unit storage lanyards to prevent the forward outer cutting units from settling when the machine is parked overnight or if it is being stored for an extended period. You can also use the cutting-unit storage lanyards to prevent the cutting units from settling while the machine is transporting between mowing tasks.

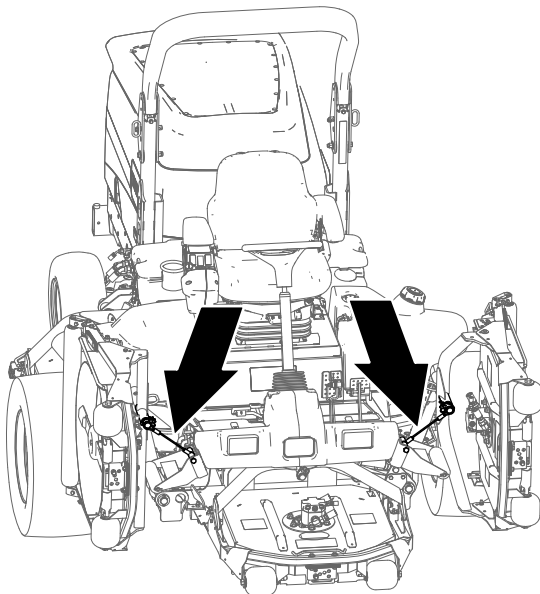
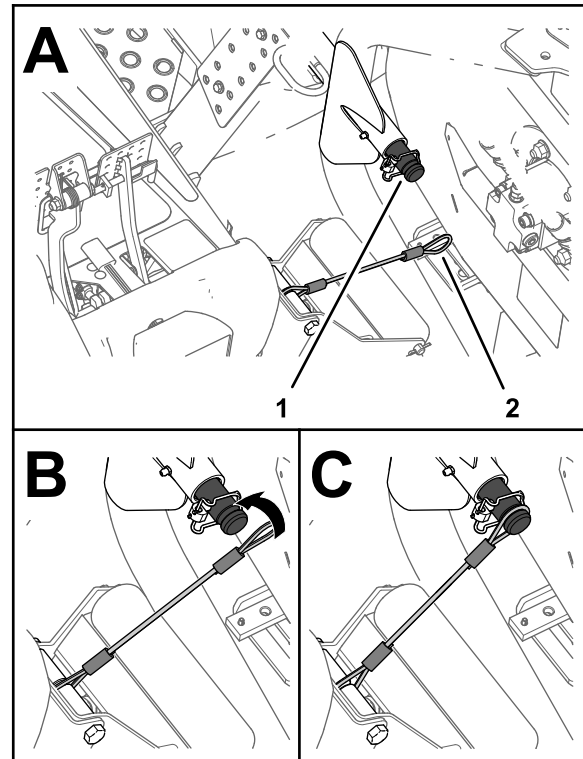

Figure 32

g225484

Securing the Cutting Units

1. Ensure that the PTO is disengaged.
2. Park the machine on a level surface.
3. Engage the parking brake.
4. Fully raise the cutting units.
5. Align the lanyard to the carrier shaft of the lift arm for the forward outer-cutting unit (Figure 33).



g225483

Figure 33

1. Carrier-shaft groove (forward outer-lift arm)
2. Lanyard loop

6. Slip the loop in the lanyard over the carrier shaft until the lanyard is fully seated in the groove in the shaft (Figure 33).
7. Repeat steps 5 and 6 for the forward outer-cutting unit at the other side of the machine.

Important: Remove the lanyards from the carrier shafts before lowering the cutting units

Stowing the Lanyards

Note: Stow the lanyards when you are not using them.

1. Ensure that the PTO is disengaged.
2. Park the machine on a level surface.
3. Engage the parking brake.

4. With the cutting units lowered, slip the loop of the lanyard into the slot in the reinforcement plate of the roller support (Figure 34).

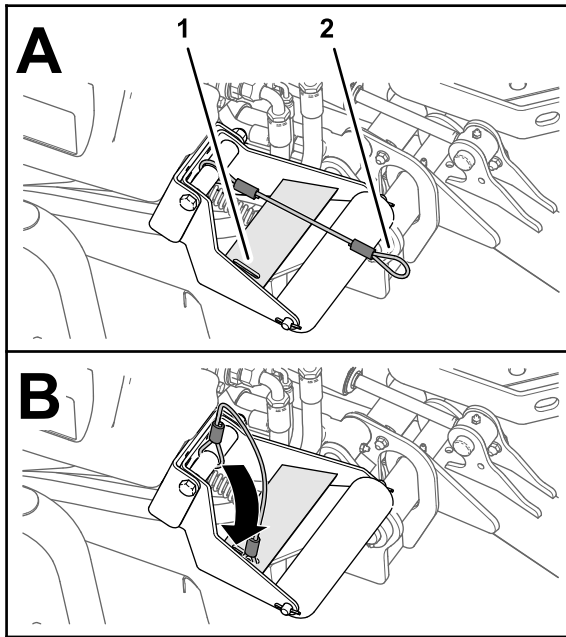

Figure 34

g225485

1. Reinforcement-plate slot
2. Lanyard loop (roller support)

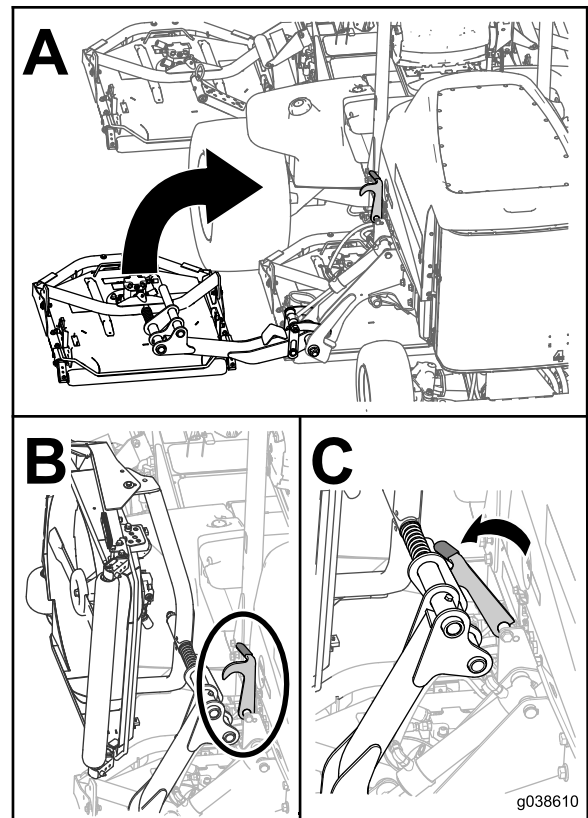

Figure 35

g038610

g038610

Using the Transport Latches

Groundsmaster 4700 Only

Use the 2 rear-transport latches for the No. 6 and 7 cutting units (Figure 15) when moving the machine over long distances, rough terrain, when transporting, or storing the machine.

Hauling the Machine

- Remove the key and shut off the fuel (if equipped) before storing or hauling the machine.
- Use care when loading or unloading the machine into a trailer or a truck.
- Use full-width ramps for loading the machine into a trailer or a truck.
- Tie the machine down securely.

Pushing or Towing the Machine

In an emergency, you can move the machine forward by actuating the bypass valve in the variable-displacement hydraulic pump and pushing or towing the machine.

Important: Do not push or tow the machine faster than 3 to 4.8 km/h (2 to 3 mph). If you push or tow at a faster speed, internal transmission damage may occur.

The bypass valves must be open whenever you push or tow the machine.

1. Open the hood and locate the bypass valves (Figure 36) on the top of pump, behind the battery/storage boxes.

- Rotate each valve 3 turns counter-clockwise to open and allow the fluid to bypass internally.

Note: Do not open the valve more than 3 turns. Because fluid is bypassed, you can move the machine slowly without damaging the transmission.

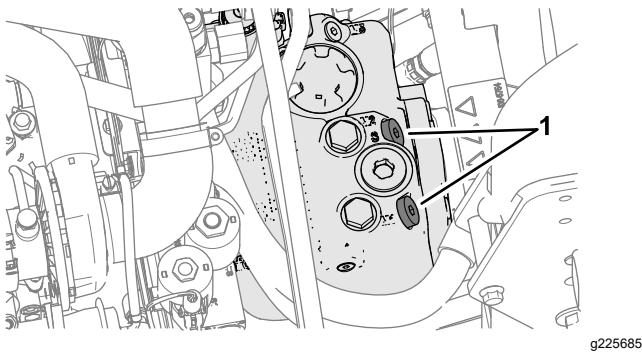
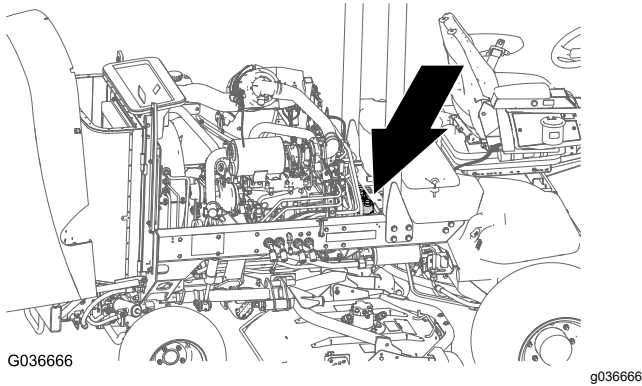

Figure 36

- Bypass valve (2)

- Push or tow the machine forward.

Important: If you must push or tow the machine in reverse, refer to the Reverse Tow Kit (Part No. 136-3620).

- Finish pushing or towing the machine and close the bypass valve. Torque the valve to 70 N·m (52 ft·lb).

Locating the Tie-Down Points

Note: Use properly-rated DOT-approved straps in 4 corners to tie down the machine.

- On each side of the frame by the operator's platform (Figure 38)
- On the rear bumper (Figure 38)

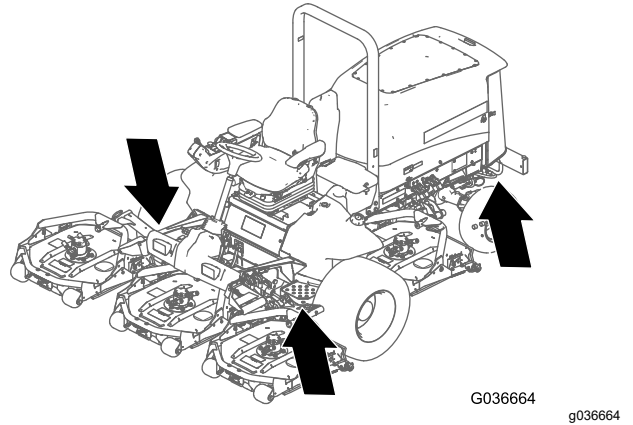

Figure 37

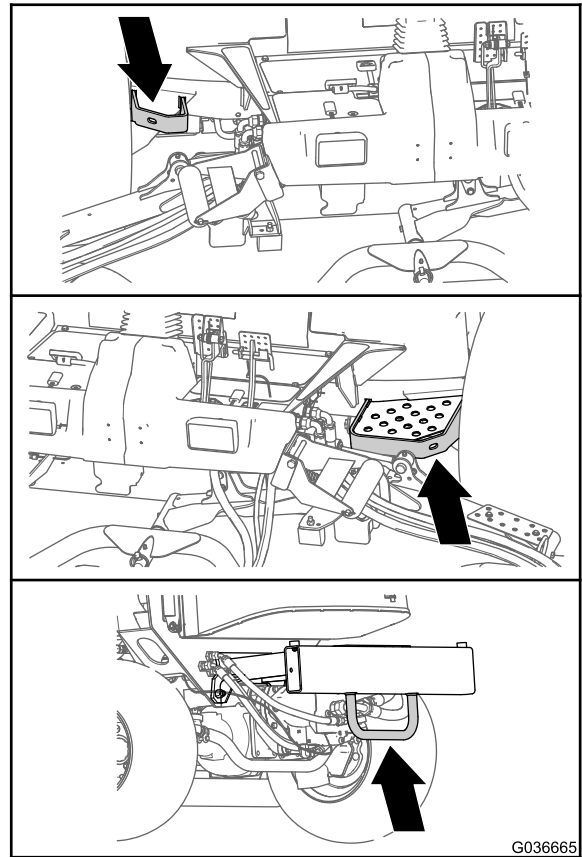

Figure 38

Maintenance

Note: Determine the left and right sides of the machine from the normal operating position.

Important: Refer to your engine owner’s manual for additional maintenance procedures.

Note: Download a free copy of the electrical or hydraulic schematic by visiting www.Toro.com and searching for your machine from the Manuals link on the home page.

Maintenance Safety

- Before you leave the operator’s position, do the following:
 - Park the machine on a level surface.
 - Disengage the power takeoff and lower the attachments.
 - Engage the parking brake.
 - Shut off the engine and remove the key.
 - Wait for all movement to stop.
- If you leave the key in the switch, someone could accidentally start the engine and seriously injure you or other bystanders. Remove the key from the switch before you perform any maintenance.
- Allow machine components to cool before performing maintenance.
- If the cutting units are in the transport position, use the positive mechanical lock (if equipped) before you leave the machine unattended.
- If possible, do not perform maintenance while the engine is running. Keep away from moving parts.
- Support the machine with jack stands whenever you work under the machine.
- Carefully release pressure from components with stored energy.
- Keep all parts of the machine in good working condition and all hardware tightened, especially blade-attachment hardware.
- Replace all worn or damaged decals.
- To ensure safe, optimal performance of the machine, use only genuine Toro replacement parts. Replacement parts made by other manufacturers could be dangerous, and such use could void the product warranty.

Recommended Maintenance Schedule(s)

Maintenance Service Interval	Maintenance Procedure
After the first hour	<ul style="list-style-type: none"> • Torque the wheel lug nuts.
After the first 10 hours	<ul style="list-style-type: none"> • Torque the wheel lug nuts.
After the first 50 hours	<ul style="list-style-type: none"> • Change the front planetary-gear oil.
After the first 200 hours	<ul style="list-style-type: none"> • Change the rear-axle lubricant.
Before each use or daily	<ul style="list-style-type: none"> • Check the tire pressure. • Check the interlock switches. • Check the blade-stopping time. • Check the engine-oil level. • Drain water or other contaminants from the fuel filter/water separator • Check the rear axle and rear-axle gearbox for leaks. • Check level of coolant at the beginning of each day. • Remove debris from the engine area, oil cooler, and radiator (clean them more frequently in dirty conditions). • Check the hydraulic-fluid level. • Inspect the hydraulic lines and hoses for leaks, kinked lines, loose mounting supports, wear, loose fittings, weather deterioration, and chemical deterioration. • Clean the machine. • Clean and maintain the seat belt.
Every 50 hours	<ul style="list-style-type: none"> • Grease the bearings and bushings (also after every washing). • Check the battery condition.
Every 100 hours	<ul style="list-style-type: none"> • Check the condition and tension of the alternator belt.

Maintenance Service Interval	Maintenance Procedure
Every 200 hours	<ul style="list-style-type: none"> • Torque the wheel lug nuts.
Every 250 hours	<ul style="list-style-type: none"> • Change the engine oil and filter.
Every 400 hours	<ul style="list-style-type: none"> • Service the air cleaner (earlier if the air-cleaner indicator shows red, and more frequently in extremely dirty or dusty conditions). • Inspect the fuel lines and connections. • Replace the fuel-filter canister. • Replace the engine fuel filter. • Check for end-play in the planetary drives. • Check the planetary-gear-drive oil level (check if you notice external leakage). • Check the rear-axle lubricant. • Check the rear-axle-gear-box lubricant.
Every 800 hours	<ul style="list-style-type: none"> • Drain and clean the fuel tank. • Change the front planetary-gear oil or yearly, whichever comes first. • Change the rear-axle lubricant. • Check the rear wheel toe-in. • If you are not using the recommended hydraulic fluid or have ever filled the reservoir with an alternative fluid, change the hydraulic fluid. • If you are not using the recommended hydraulic fluid or have ever filled the reservoir with an alternative fluid, replace the hydraulic filter (sooner if the service interval indicator is in the red zone).
Every 1,000 hours	<ul style="list-style-type: none"> • If you are using the recommended hydraulic fluid, replace the hydraulic filter (sooner if the service interval indicator is in the red zone).
Every 2,000 hours	<ul style="list-style-type: none"> • If you are using the recommended hydraulic fluid, change the hydraulic fluid.
Before storage	<ul style="list-style-type: none"> • Drain and clean the fuel tank. • Check the tire pressure. • Check all fasteners. • Grease or oil all grease fittings and pivot points. • Paint chipped surfaces.
Every 2 years	<ul style="list-style-type: none"> • Drain and flush the hydraulic tank. • Replace the hydraulic hoses.

Daily Maintenance Checklist

Duplicate this page for routine use.

Maintenance Check Item	For the week of:						
	Monday	Tuesday	Wednesday	Thursday	Friday	Saturday	Sunday
Check the safety-interlock operation.							
Check the brake operation.							
Check the engine-oil level.							
Check the cooling-system-fluid level.							
Drain the water/fuel separator.							
Check the air filter, dust cup, and burp valve.							
Check for unusual engine noises. ¹							
Check the radiator and screen for debris							

Maintenance Check Item	For the week of:						
	Monday	Tuesday	Wednesday	Thursday	Friday	Saturday	Sunday
Check for unusual operating noises.							
Check the hydraulic-fluid level.							
Check the hydraulic hoses for damage.							
Check for fluid leaks.							
Check the fuel level.							
Check the tire pressure.							
Check the instrument operation.							
Check the height-of-cut adjustment.							
Lubricate all the grease fittings. ²							
Clean the machine.							
Touch up any damaged paint.							
¹ Check the glow plug and injector nozzles if starting is hard, there is excess smoke, or rough running is noted. ² Immediately after every washing, regardless of the interval listed.							

Important: Refer to your engine operator’s manual for additional maintenance procedures.

Notation for Areas of Concern

Inspection performed by:		
Item	Date	Information

Pre-Maintenance Procedures

Lifting the Machine

Use the following as points to lift the machine:

Front of the machine—at the frame of the machine, forward of the wheel-drive motors ([Figure 39](#))

Important: Do not support the machine at the wheel-drive motors. Keep the lifting equipment clear of hydraulic tubing and hoses.

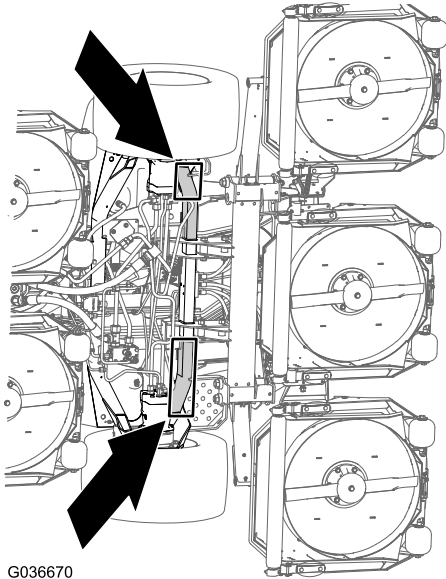

G036670

Figure 39

g036670

Rear of the machine—at the center of the axle ([Figure 40](#))

Locate the jackstands of the specified capacity at both sides of the gear case and under the axle.

Important: Do not support the machine at the tie rod.

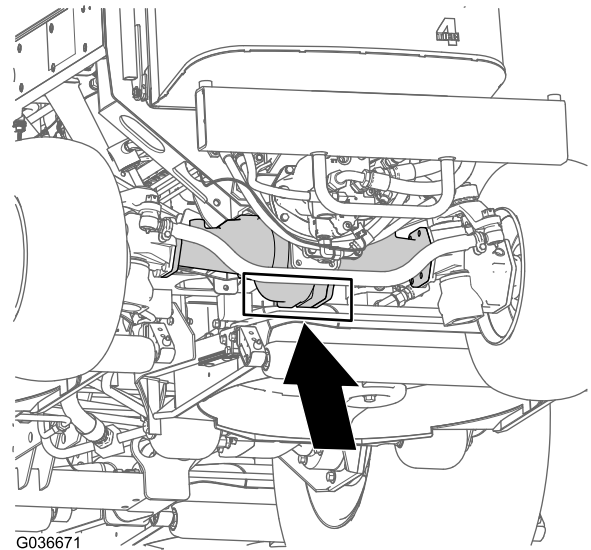

G036671

Figure 40

g036671

Opening the Hood

Tilt the hood to access the chassis as shown in [Figure 41](#).

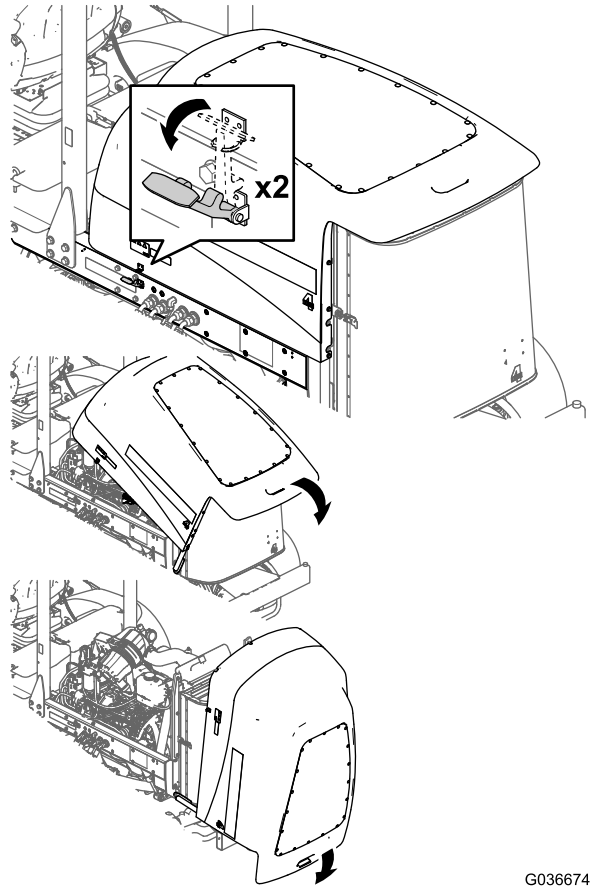

G036674

Figure 41

g036674

Accessing the Hydraulic Lift Compartment

Tilt the seat to access the hydraulic lift compartment as shown in [Figure 42](#).

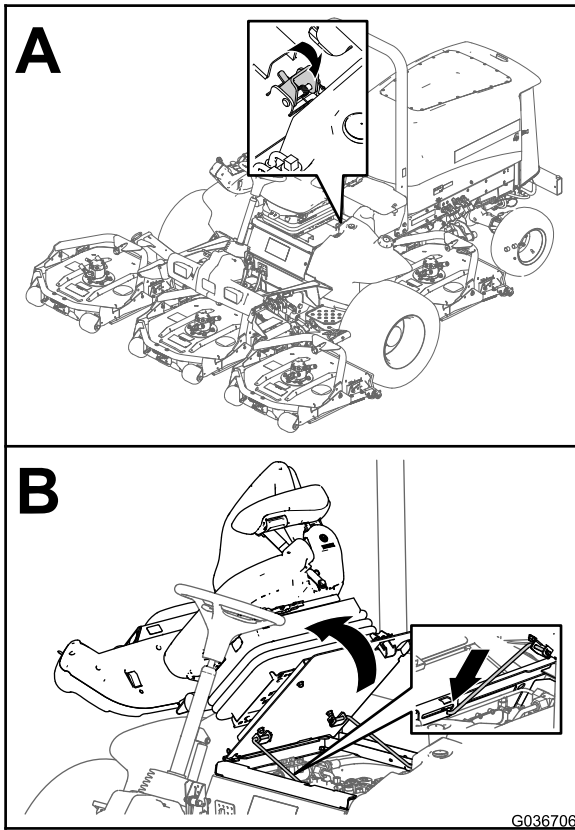

Figure 42

g036706

Lubrication

Greasing the Bearings and Bushings

Service Interval: Every 50 hours (also after every washing).

Grease specification: No. 2 lithium grease

The grease fitting locations and quantities are as follows:

- Brake-shaft pivot bearings (5) as shown in [Figure 43](#)

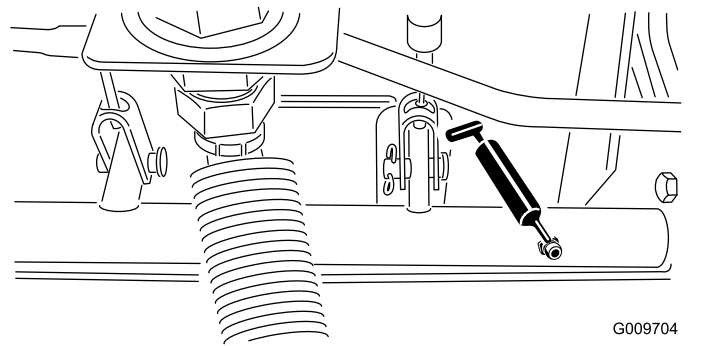

Figure 43

- Rear-axle-pivot bushings (2) as shown in [Figure 44](#)

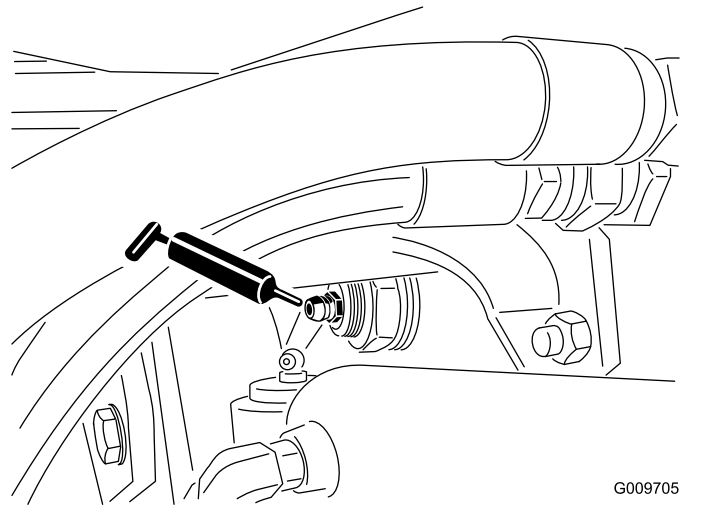

Figure 44

- Steering-cylinder ball joints (2) as shown in [Figure 45](#)

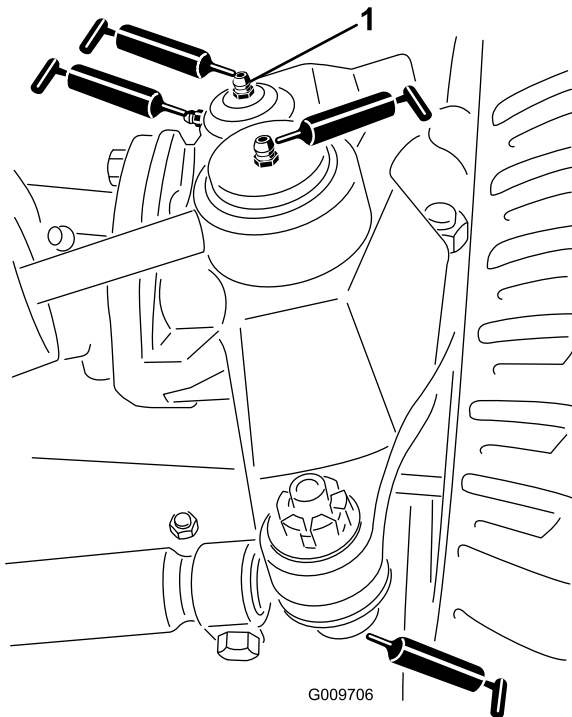

Figure 45

- Top fitting on kingpin

- Tie-rod ball joints (2) as shown in [Figure 45](#)
- Kingpin bushings (2) as shown in [Figure 45](#)

Important: Lubricate the top fitting on the kingpin no more than annually (2 pumps).

- Lift-arm bushings (1 per cutting unit) as shown in [Figure 46](#)

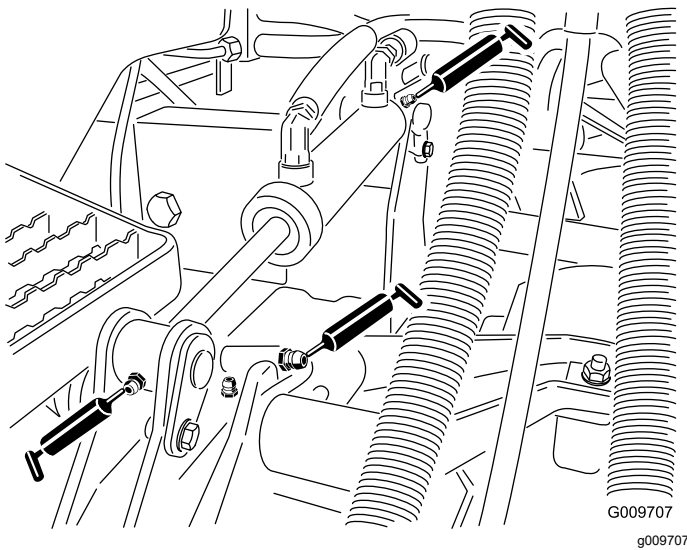

Figure 46

- Lift-cylinder bushings (2 per cutting unit) as shown in [Figure 46](#)

- Cutting-unit spindle-shaft bearings (2 per cutting unit) as shown in [Figure 47](#)

Note: You can use either fitting, whichever is more accessible. Pump grease into the fitting until a small amount appears at the bottom of the spindle housing (under the cutting unit).

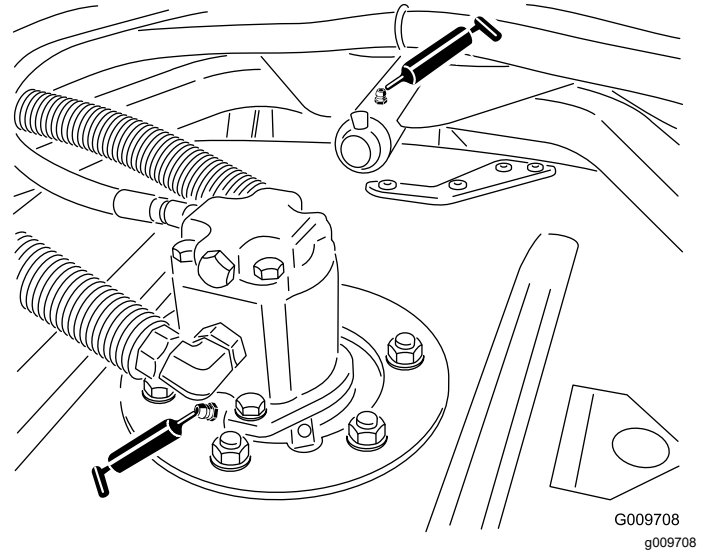

Figure 47

- Cutting-unit carrier-arm bushings (1 per cutting unit) as shown in [Figure 47](#)
- Rear roller bearings (2 per cutting unit) as shown in [Figure 48](#)

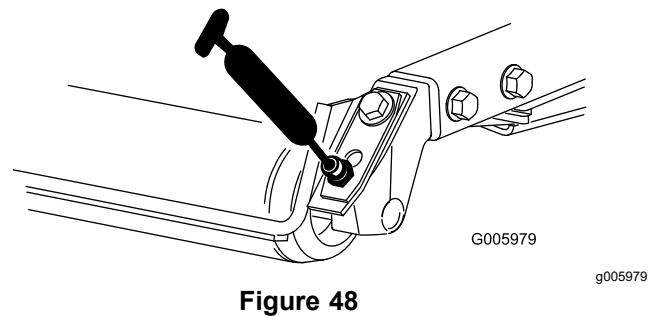

Figure 48

Important: Make sure that the grease groove in each roller mount aligns with the grease hole in each end of the roller shaft. To help align the groove and the hole, there is also an alignment mark on 1 end of the roller shaft.

Engine Maintenance

Engine Safety

- Shut off the engine and remove the key before checking the oil or adding oil to the crankcase.
- Do not change the governor speed or overspeed the engine.

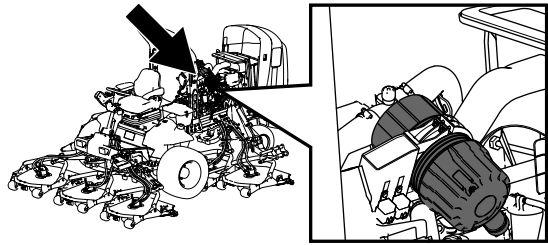

g198631

Servicing the Air Cleaner

Service Interval: Every 400 hours

Check the air-cleaner body for damage which could cause an air leak. Replace it if it is damaged. Check the whole intake system for leaks, damage, or loose hose clamps.

Service the air-cleaner filter only when the service indicator (Figure 49) requires it. Changing the air filter before it is necessary only increases the chance of dirt entering the engine when you remove the filter.

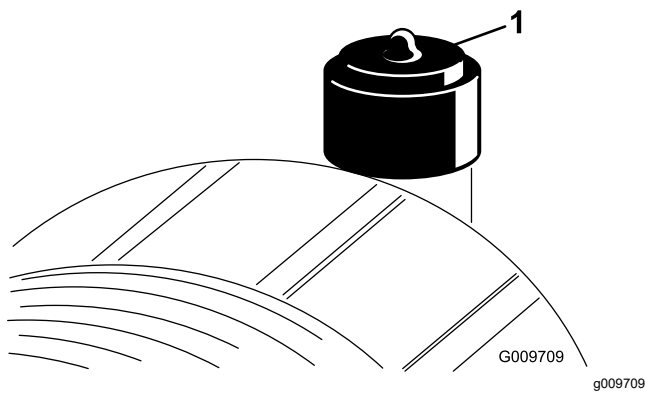

Figure 49

1. Air-cleaner indicator

Important: Ensure that the cover is seated correctly and seals with the air-cleaner body.

1. Replace the air cleaner (Figure 50).

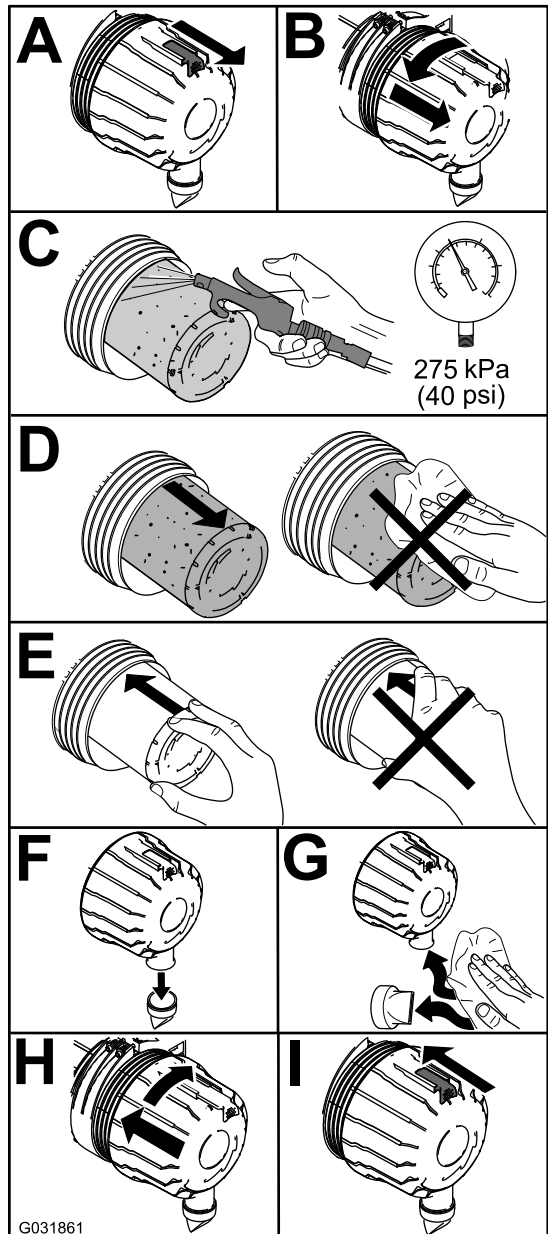

Figure 50

g031861

Note: Do not clean a used element because cleaning it can damage the filter media.

Important: Never attempt to clean the safety filter (Figure 51). Replace the safety filter after every 3 primary filter services.

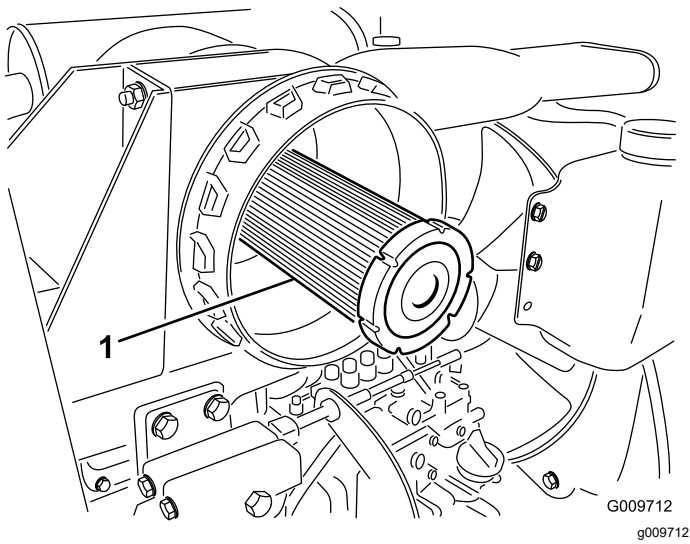

Figure 51

1. Air-cleaner safety filter
-
2. Reset the indicator (Figure 49) if it shows red.

Servicing the Engine Oil

Oil Specification

Use high-quality, low-ash engine oil that meets or exceeds the following specifications:

- API service category CI-4 or higher
- ACEA service category E6
- JASO service category DH-2

Important: Using engine oil other than API CJ-4 or higher, ACEA E6, or JASO DH-2 may cause the diesel particulate filter to plug or cause engine damage.

Use the following engine oil viscosity grade:

- Preferred oil: SAE 15W-40 (above 0°F)
- Alternate oil: SAE 10W-30 or 5W-30 (all temperatures)

Toro Premium Engine Oil is available from your authorized Toro distributor in either 15W-40 or 10W-30 viscosity grades. See the *Parts Catalog* for part numbers.

Checking the Engine-Oil Level

Service Interval: Before each use or daily

The engine is shipped with oil in the crankcase; however, the oil level must be checked before and after the engine is first started.

Important: Check the engine oil daily. If the engine-oil level is above the Full mark on the dipstick, the engine oil may be diluted with fuel;

If the engine oil level is above the Full mark, change the engine oil.

The best time to check the engine oil is when the engine is cool before it has been started for the day. If it has already been run, allow the oil to drain back down to the sump for at least 10 minutes before checking. If the oil level is at or below the Add mark on the dipstick, add oil to bring the oil level to the Full mark. **Do not overfill the engine with oil.**

Important: Keep the engine-oil level between the upper and lower limits on the dipstick; the engine may fail if you run it with too much or too little oil.

Check the engine-oil level; refer to Figure 52.

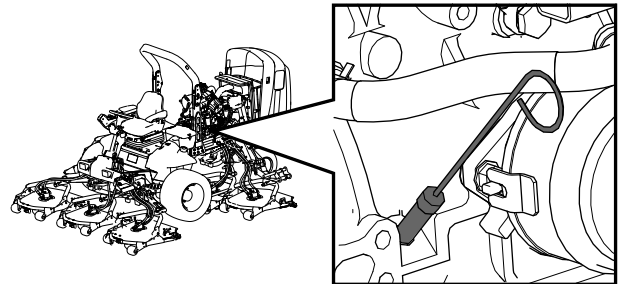

g198647

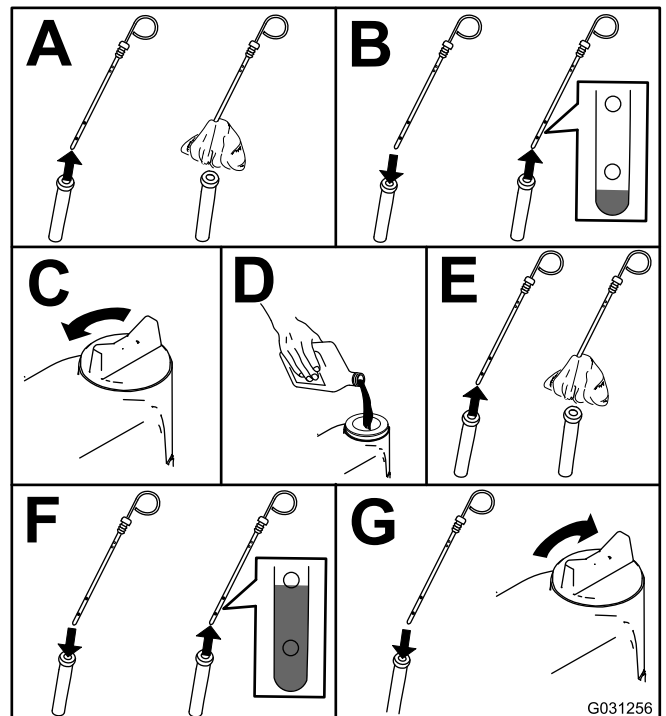

G031256

g031256

Figure 52

Note: When using different oil, drain all old oil from the crankcase before adding new oil.

Crankcase Oil Capacity

Approximately 5.7 L (6 US qt) with the filter.

Changing the Engine Oil and Filter

Service Interval: Every 250 hours

Note: To reset the service due indicator in the Infocenter; refer to [Setting the Service Due Timer](#) (page 31).

1. Start the engine and let it run 5 minutes to allow the oil to warm up.
2. Park the machine on a level surface, engage the parking brake, shut off the engine, and remove the key.
3. Replace the engine oil and filter ([Figure 53](#)).

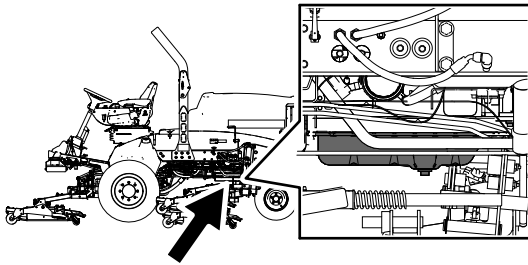

g198660

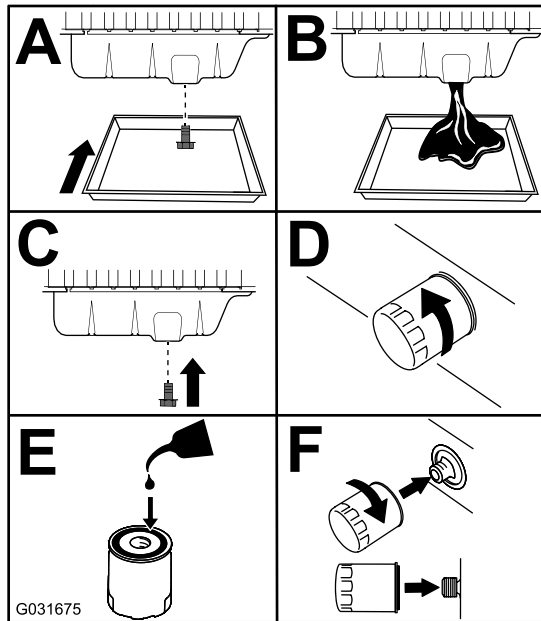

Figure 53

g031675

4. Add oil to the crankcase; refer to the [Crankcase Oil Capacity](#) (page 51) and [Checking the Engine-Oil Level](#) (page 50).

Fuel System Maintenance

⚠ DANGER

Under certain conditions, diesel fuel and fuel vapors are highly flammable and explosive. A fire or explosion from fuel can burn you and others and can cause property damage.

- Use a funnel to fill the fuel tank outdoors, in an open area, when the engine is off and is cold. Wipe up any fuel that spills.
- Do not fill the fuel tank completely full. Add fuel to the fuel tank until the level is 6 to 13 mm (1/4 to 1/2 inch) below the bottom of the filler neck. This empty space in the tank allows the fuel to expand.
- Never smoke when handling fuel, and stay away from an open flame or where fuel fumes may be ignited by a spark.
- Store fuel in a clean, safety-approved container and keep the cap in place.

Draining the Fuel Tank

Service Interval: Every 800 hours—Drain and clean the fuel tank.

Before storage—Drain and clean the fuel tank.

In addition to the listed service interval, drain and clean the tank if the fuel system becomes contaminated or if you are storing the machine for an extended period. Use clean fuel to flush out the tank.

Inspecting the Fuel Lines and Connections

Service Interval: Every 400 hours/Yearly (whichever comes first)

Inspect the fuel lines for deterioration, damage, or loose connections.

Servicing the Fuel-Water Separator

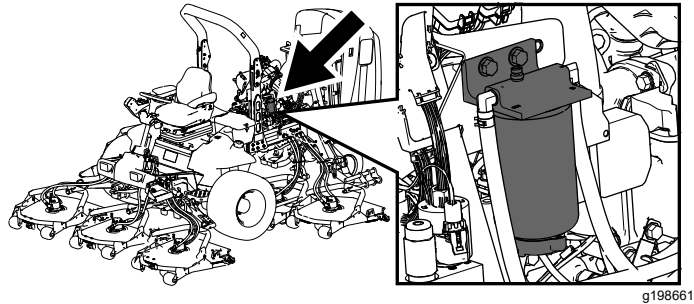

Figure 54

Draining Water from the Fuel/Water Separator

Service Interval: Before each use or daily—Drain water or other contaminants from the fuel filter/water separator

Drain water from the fuel/water separator as shown in (Figure 55).

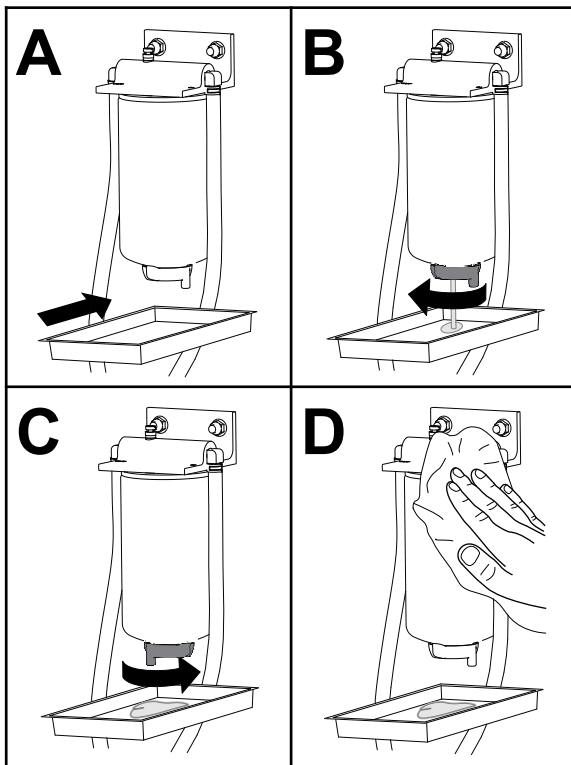

Figure 55

Replacing the Fuel-Filter Canister

Service Interval: Every 400 hours—Replace the fuel-filter canister.

Replace the fuel-filter canister as shown in Figure 56.

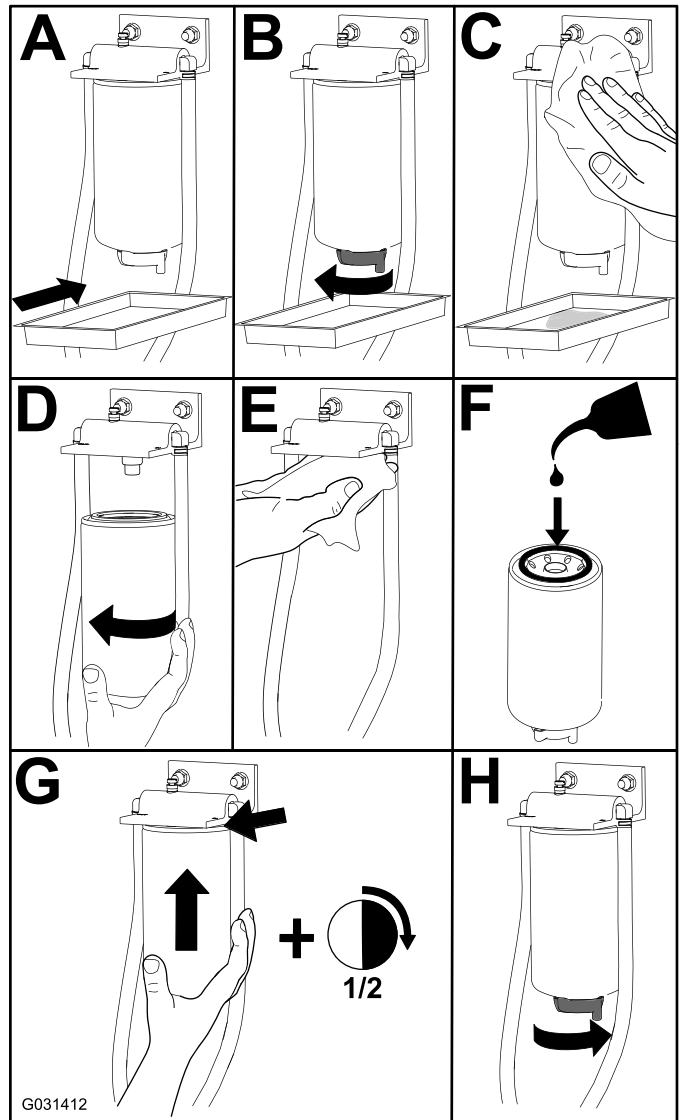

Figure 56

Servicing the Fuel Filter

Service Interval: Every 400 hours

1. Clean the area around the fuel-filter head (Figure 57).

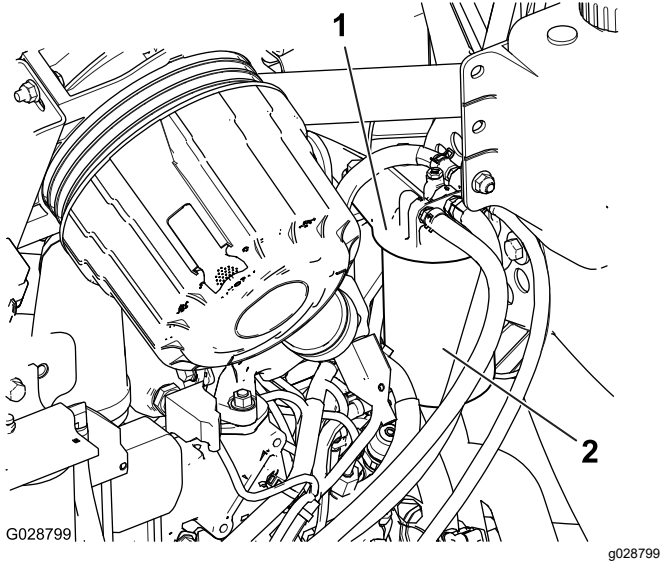

Figure 57

1. Fuel-filter head
2. Fuel filter

2. Remove the filter and clean the filter head mounting surface (Figure 57).
3. Lubricate the filter gasket with clean lubricating engine oil; refer to the engine owner's manual for additional information.
4. Install the dry filter canister, by hand, until the gasket contacts the filter head, then rotate it an additional 1/2 turn.
5. Prime the filter and the lines to the high pressure pump; refer to [Priming the Fuel System \(page 54\)](#).
6. Start the engine and inspect for leaks around the filter head again.

Cleaning the Fuel-Pickup Tube Screen

The fuel-pickup tube, located inside the fuel tank, is equipped with a screen to help prevent debris from entering the fuel system. Remove the fuel-pickup tube and clean the screen as required.

1. Remove the hose clamp that secures the fuel supply hose to the fitting of the fuel-pickup tube (Figure 58).

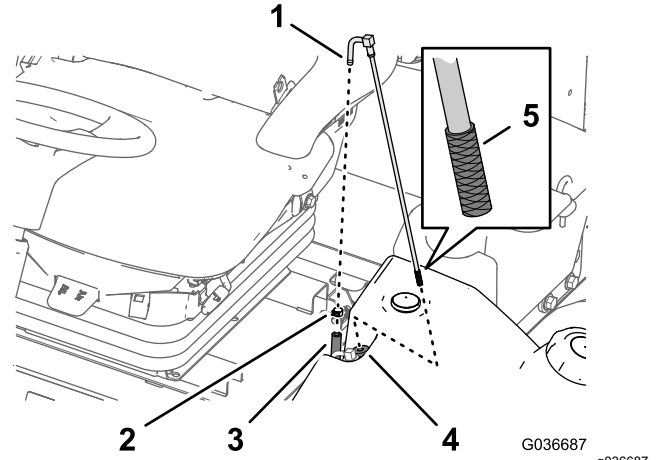

Figure 58

1. Fitting (fuel-pickup tube)
2. Hose clamp
3. Fuel supply hose
4. Rubber bushing
5. Screen

2. Separate the hose from the fitting (Figure 58).
3. Lift the fuel-pickup tube from the fuel tank (Figure 58).
Note: Lift the tube straight from the bushing in the tank.
4. Clean any debris from the screen at the end of the fuel-pickup tube (Figure 58).
5. Insert the fuel-pickup tube through the rubber bushing and into the tank (Figure 58).
Note: Ensure that the fuel-pickup tube is fully seated into the rubber bushing.
6. Install the supply hose onto the fitting of the fuel-pickup tube, and secure the hose with the hose clamp that you removed in step 1.

Priming the Fuel System

Prime the fuel system before starting the engine for the first time, after running out of fuel, or after fuel system maintenance (e.g., draining the filter/water separator, replacing a fuel hose).

To prime the fuel system, perform the following steps:

1. Ensure that fuel is in the fuel tank.
2. Perform the following steps to prime the filter and the lines to the high pressure pump to prevent wear or damage to the pump:
 - A. Cycle the key to the ON position for 15 to 20 seconds.
 - B. Cycle the key to the OFF position for 30 to 40 seconds.
Note: This allows the ECU to power down.
 - C. Cycle the key to the ON position for 15 to 20 seconds.
 - D. Inspect for leaks around the filter and hoses.

Important: Do not use the engine starter motor to crank the engine to prime the fuel system.

Electrical System Maintenance

Electrical System Safety

- Disconnect the battery before repairing the machine. Disconnect the negative terminal first and the positive last. Connect the positive terminal first and the negative last.
- Charge the battery in an open, well-ventilated area, away from sparks and flames. Unplug the charger before connecting or disconnecting the battery. Wear protective clothing and use insulated tools.

Checking the Battery Condition

Service Interval: Every 50 hours

Important: Before welding on the machine, disconnect the negative cable from the battery to prevent damage to the electrical system. Also, you must disconnect the engine, InfoCenter, and machine controllers before welding on the machine.

Note: Keep the terminals and the entire battery case clean, because a dirty battery discharges slowly. To clean the battery, wash the entire case with a solution of baking soda and water. Rinse with clear water. Coat the battery posts and cable connectors with Grafo 112X (skin-over) grease (Toro Part No. 505-47) or petroleum jelly to prevent corrosion.

Charging and Connecting the Battery

1. Loosen the latch for the cover of the right storage box and raise the cover (Figure 61).

▲ DANGER

Battery electrolyte contains sulfuric acid, which is fatal if consumed and causes severe burns.

- Do not drink electrolyte and avoid contact with skin, eyes, or clothing. Wear safety glasses to shield your eyes and rubber gloves to protect your hands.
- Fill the battery where clean water is always available for flushing the skin.

2. Remove the rubber boot from the positive terminal and inspect the battery.
3. Remove the negative cable (black) from the negative (-) terminal and the positive cable (red) from the positive (+) terminal of the battery (Figure 59).

⚠ WARNING

Incorrect battery cable routing could damage the machine and cables, causing sparks. Sparks can cause the battery gasses to explode, resulting in personal injury.

- **Always disconnect the negative (black) battery cable before disconnecting the positive (red) cable.**
- **Always connect the positive (red) battery cable before connecting the negative (black) cable.**

⚠ WARNING

Battery terminals or metal tools could short against metal components, causing sparks. Sparks can cause the battery gasses to explode, resulting in personal injury.

- **When removing or installing the battery, do not allow the battery terminals to touch any metal parts of the machine.**
- **Do not allow metal tools to short between the battery terminals and metal parts of the machine.**

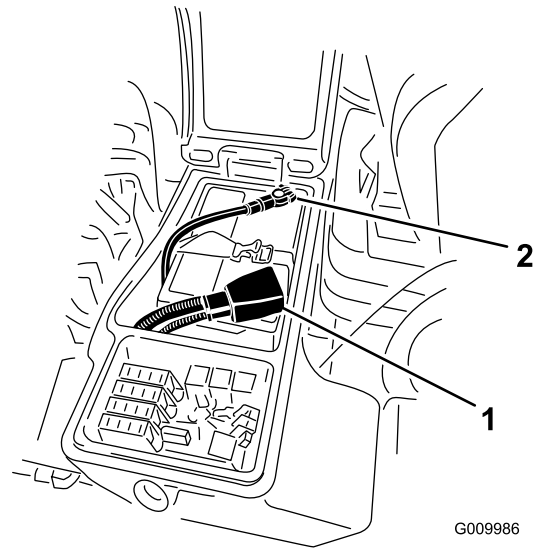

Figure 59

1. Positive battery cable
2. Negative battery cable

4. Connect a 3 to 4 A battery charger to the battery posts. Charge the battery at a rate of 3 to 4 A for 4 to 8 hours.

⚠ WARNING

Charging the battery produces gasses that can explode.

Never smoke near the battery and keep sparks and flames away from battery.

5. When the battery is charged, disconnect the charger from the power outlet and battery posts.
6. Install the positive cable (red) to the positive (+) terminal and the negative cable (black) to the negative (-) terminal of the battery (Figure 59).
7. Secure the cables to the posts with bolts and nuts.

Note: Make sure that the positive (+) terminal is all the way on the post and the cable is positioned snug to the battery. The cable must not contact the battery cover.

8. Coat both battery connections with Grafo 112X (skin-over) grease, Part No. 505-47, petroleum jelly, or light grease to prevent corrosion.
9. Slide the rubber boot over the positive terminal.
10. Close the console panel and secure the latch.

Locating the Fuses

The fuse block for the machine is located in the right storage box

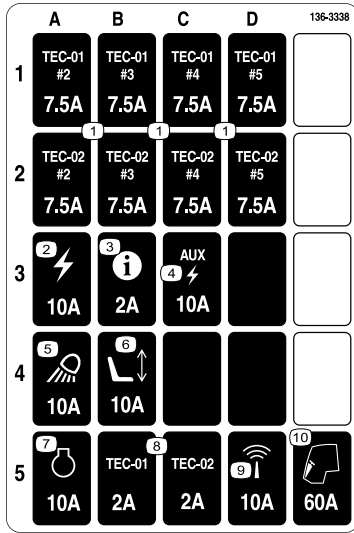
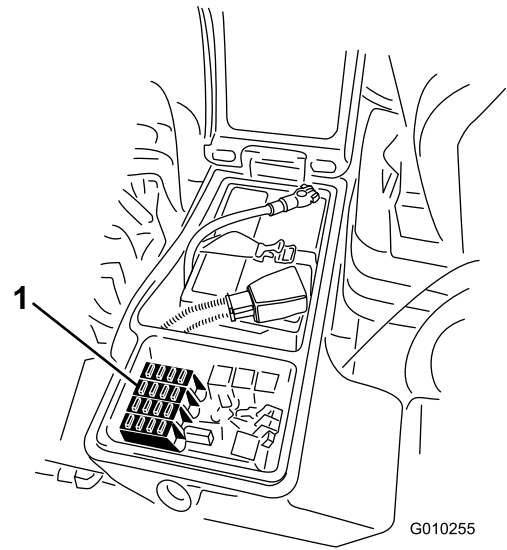

Figure 60

decal136-3338



G010255

g010255

Figure 62

1. Fuses

3. Close the cover of the right storage box and secure the cover with the latch (Figure 61).

1. Loosen the latch for the cover of the right storage box and raise the cover (Figure 61) to expose the fuse block (Figure 62).

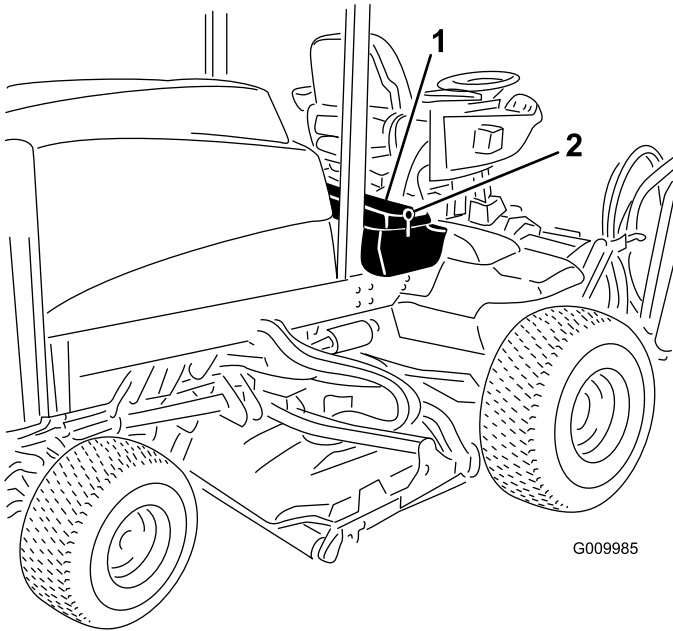

G009985

g009985

Figure 61

1. Latch

2. Right storage box

2. Replace the open fuse(s) as needed (Figure 62).

Drive System Maintenance

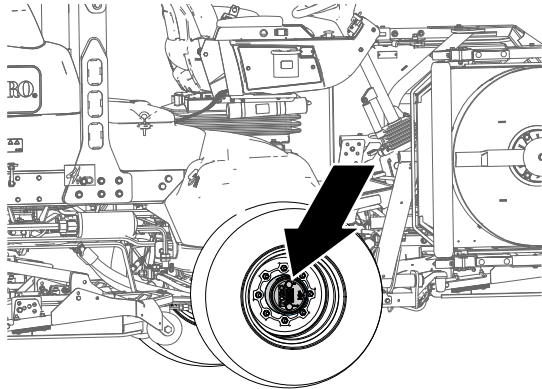

Figure 63

g225611

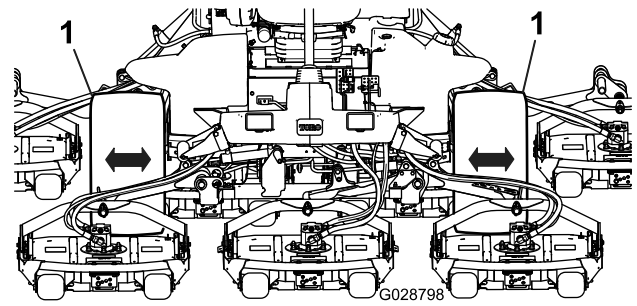

Figure 64

g028798

1. Front drive wheels

4. Repeat step 3 for the other drive wheel.
5. If either wheel moves, contact your authorized Toro distributor to have the planetary drive rebuilt.

Checking for End-Play in the Planetary Drives

Service Interval: Every 400 hours

There should be no end-play in the planetary drives/drive wheels (i.e., the wheels should not move when you pull or push them in a direction parallel to the axle).

1. Park the machine on a level surface, engage the parking brake, lower the cutting units, shut off the engine, and remove the key.
2. Chock the rear wheels and raise the front of machine, supporting the front axle/frame on jack stands.

⚠ DANGER

A machine on a jack may be unstable and slip off the jack, injuring anyone beneath it.

- Do not start the engine while the machine is on a jack.
 - Always remove the key from the switch before getting off the machine.
 - Block the tires when you are raising the machine with a jack.
 - Support the machine with jack stands.
3. Grasp 1 of the front drive wheels and push/pull it toward and away from the machine, noting any movement.

Checking the Planetary Gear-Drive Lubricant

Service Interval: Every 400 hours (check if you notice external leakage).

Lubricant Specification: high quality SAE 85W-140 gear lubricant

1. Park the machine on level surface, position the wheel so that the fill plug is at the 12 o'clock position, the check plug is at 3 o'clock position, and the drain plug is at the 6 o'clock position (Figure 65).

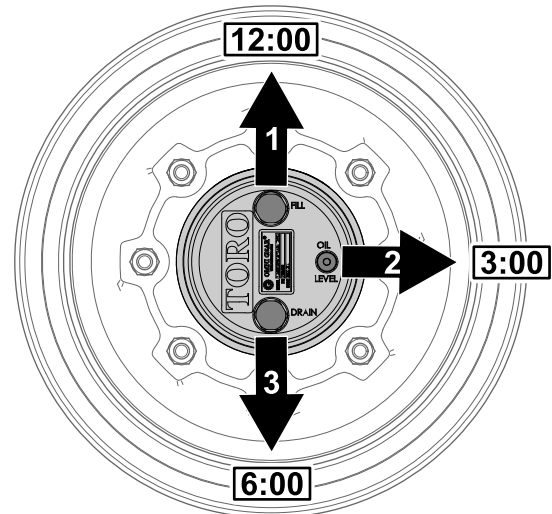

Figure 65

g225612

1. Fill plug (12 o'clock position)
2. Check plug (3 o'clock position)
3. Drain plug (6 o'clock position)

2. Remove the check plug at the 3 o'clock position (Figure 65).

The oil level should be at the bottom of the check-plug hole.

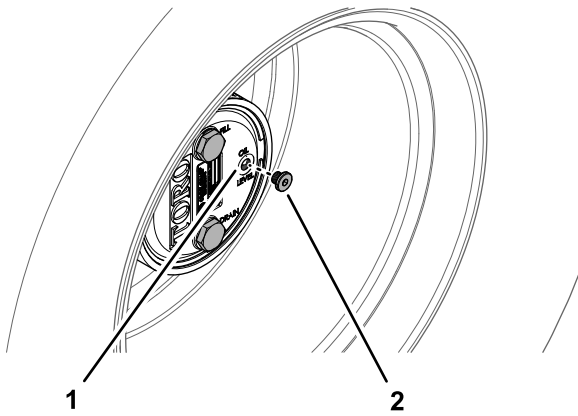

Figure 66

g225606

1. Check-plug hole
2. Check plug

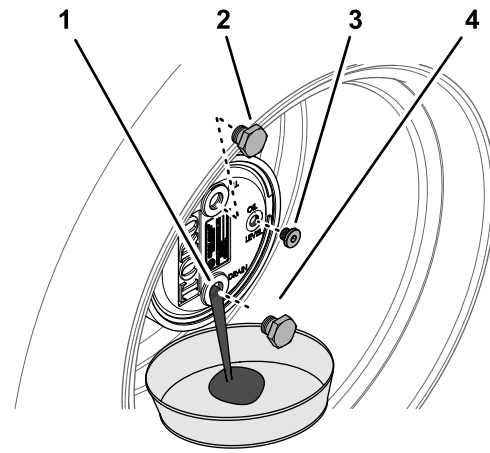

Figure 67

g225609

1. Drain-plug hole
2. Fill plug
3. Check plug
4. Drain plug

3. If the oil level is low, remove the fill plug at the 12 o'clock position and add oil until it begins to flow out of the hole at the 3 o'clock position.
4. Check the O-ring for the plug(s) for wear or damage.

Note: Replace the O-ring(s) as needed.
5. Install the plug(s).
6. Repeat steps 1 through 5 on the planetary gear assembly at the other side of the machine.

3. Place a drain pan under the planetary hub, remove the drain plug at the 6 o'clock position, and allow the oil to fully drain (Figure 67).
4. Check the O-rings for the fill, check, and drain plugs for wear or damage.

Note: Replace the O-ring(s) as needed.
5. Install the drain plug into the drain hole of the planetary housing (Figure 67).
6. Place a drain pan under the brake housing, remove the drain plug, and allow the oil to fully drain (Figure 68).

Changing the Planetary-Gear-Drive Oil

Service Interval: After the first 50 hours

Every 800 hours or yearly, whichever comes first.

Lubricant specification: high quality SAE 85W-140 gear lubricant

Planetary and brake housing lubrication capacity: 0.65 L (22 fl oz)

Draining the Planetary-Gear-Drive

1. Park the machine on level surface, position the wheel so that the fill plug is at the 12 o'clock position, the check plug is at 3 o'clock position, and the drain plug is at the 6 o'clock position; refer to Figure 65 in [Checking the Planetary Gear-Drive Lubricant](#) (page 57).
2. Remove the fill plug at the 12 o'clock position and the check plug at the 3 o'clock position (Figure 67).

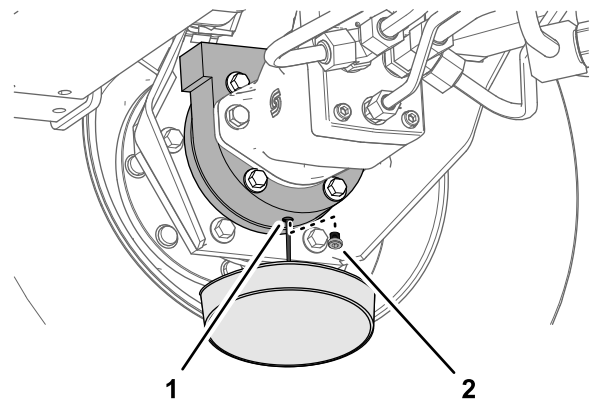

Figure 68

g225608

1. Drain hole (brake housing)
2. Drain plug

7. Check the O-ring for the plug for wear or damage and install the drain plug into the brake housing.

Note: Replace the O-ring as needed.

Filling the Planetary-Gear-Drive with Lubricant

1. Through the fill-plug hole, slowly fill the planetary with 0.65 L (22 fl oz) of high quality SAE 85W-140 wt gear lube.

Important: If the planetary fills before the 0.65 L (22 fl oz) of oil is added, wait 1 hour or install the plug and move the machine approximately ten feet to distribute the oil through the brake system. Then, remove the plug and add the remaining oil.

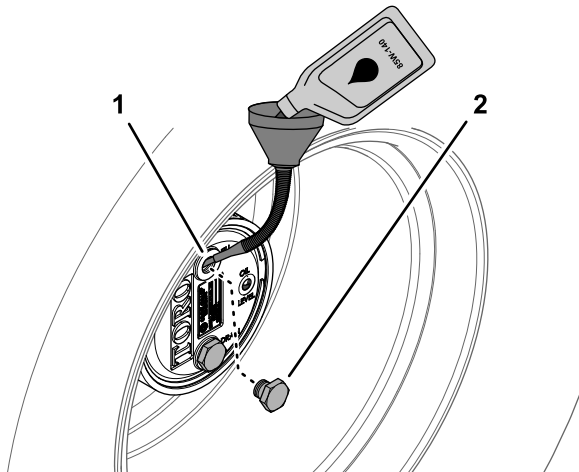

Figure 69

g225610

1. Fill-plug hole (planetary housing)
2. Fill plug

2. Install the fill plug and the check plug.
3. Wipe clean the planetary and brake housings (Figure 70).

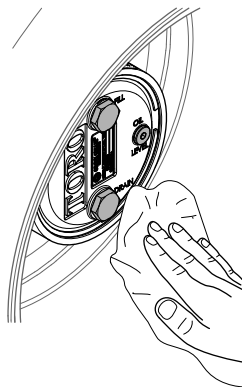

Figure 70

g225607

4. Repeat steps 1 through 7 in [Draining the Planetary-Gear-Drive \(page 58\)](#) and steps 1 through 3 in this procedure for the planetary/brake assembly at the other side of the machine.

Checking the Rear Axle and Gearbox for Leaks

Service Interval: Before each use or daily

Visually inspect the rear axle and rear-axle gearbox for leaks.

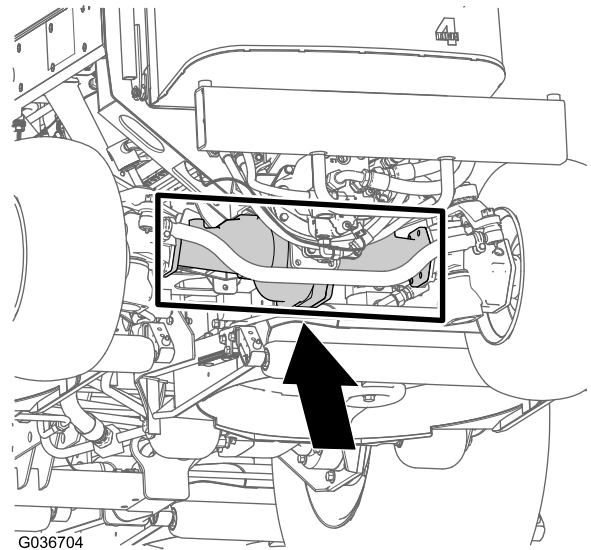

G036704

g036704

Figure 71

Checking the Rear-Axle Lubricant

Service Interval: Every 400 hours

The rear axle is filled with SAE 85W-140 gear lube. The capacity is 2.4 L (80 fl oz). Visually inspect for leaks daily.

1. Park the machine on a level surface, engage the parking brake, lower the cutting units, shut off the engine, and remove the key.
2. Remove a check plug from 1 end of the axle and ensure that the lubricant is up to the bottom of the hole (Figure 72).

Note: If the level is low, remove the fill plug and add enough lubricant to bring the level up to the bottom of the check-plug holes.

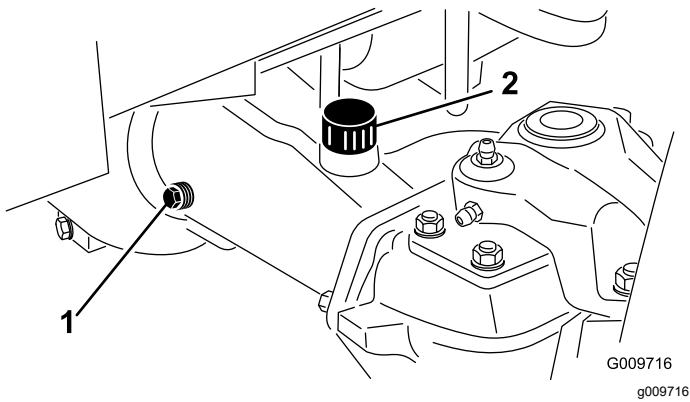

Figure 72

1. Check plug
2. Fill plug

Changing the Rear-Axle Lubricant

Service Interval: After the first 200 hours
Every 800 hours

Lubricant specification: high-quality SAE 85W-140 gear lubricant

Axle capacity: 2.4 L (80 fl oz)

1. Park the machine on a level surface, engage the parking brake, lower the cutting units, shut off the engine, and remove the key.
2. Clean the area around the 3 drain plugs—1 on each end and 1 in the center ([Figure 73](#)).

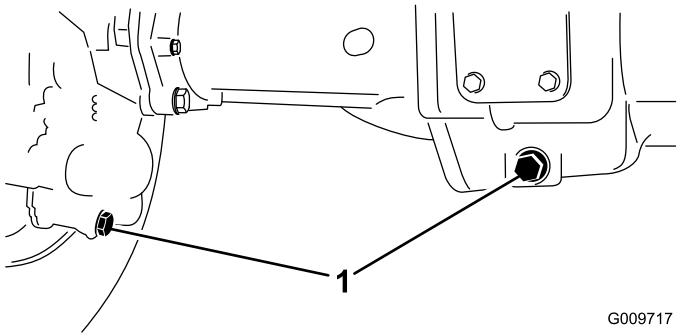

Figure 73

1. Drain-plug location

3. Remove the oil-level check plugs and the main-axle-vent cap to ease draining the gear lubricant.
4. Remove the drain plugs and allow the gear lubricant to drain into the pans.
5. Install the plugs.
6. Remove a check plug and fill the axle with approximately 2.4 L (80 fl oz) of 85W-140 gear

lube or until the lubricant is up to the bottom of the hole.

7. Install the check plug.

Checking the Rear-Axle-Gearbox Lubricant

Service Interval: Every 400 hours

The gear box is filled with SAE 85W-140 gear lube. The capacity is 0.5 L (16 fl oz). Visually inspect for leaks daily.

1. Park the machine on a level surface, engage the parking brake, lower the cutting units, shut off the engine, and remove the key.
2. Remove the check/fill plug from the left side of the gear box and ensure that lubricant is up to the bottom of the hole ([Figure 74](#)).

Note: If the level is low, add enough lubricant to bring the level up to the bottom of the hole.

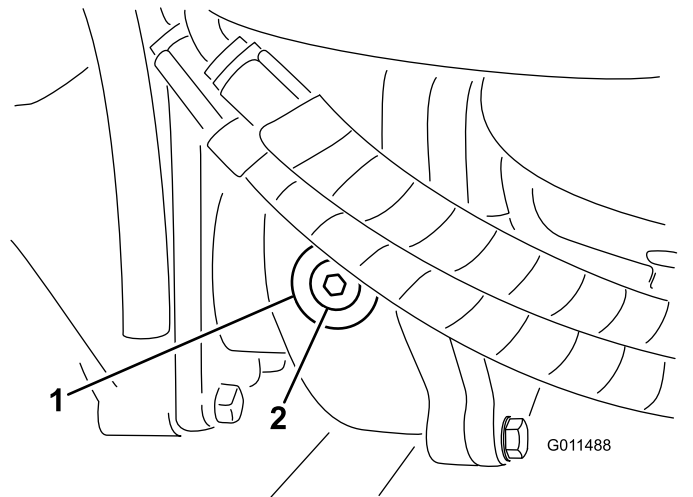

Figure 74

1. Gearbox
2. Check/fill plug

Checking the Rear Wheel Toe-In

Service Interval: Every 800 hours/Yearly (whichever comes first)

1. Park the machine on a level surface, engage the parking brake, lower the cutting units, shut off the engine, and remove the key.
2. Measure the center-to-center distance (at axle height) at the front and rear of the steering tires ([Figure 75](#)).

Note: The front measurement must be 3 mm (1/8 inch) less than the rear measurement.

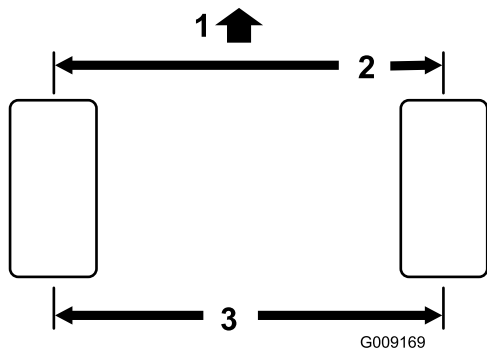

Figure 75

1. Front of the machine
2. 3 mm (1/8 inch) less than the rear measurement
3. Center to center distance

3. To adjust, remove the cotter pin and nut from either tie rod ball joint (Figure 76). Remove the tie-rod ball joint from the axle-case support.

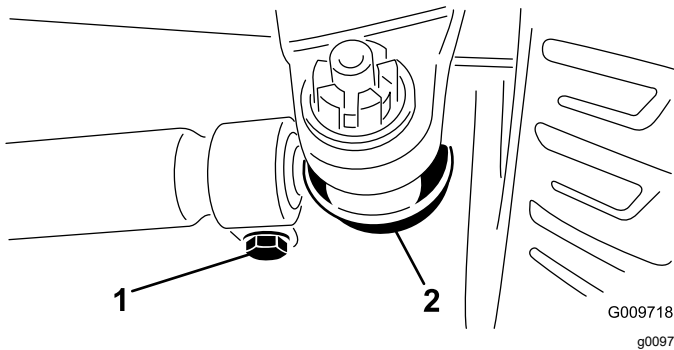

Figure 76

1. Tie-rod clamp
2. Tie-rod ball joint

4. Loosen the clamps at both ends of the tie rods (Figure 76).
5. Rotate the detached ball joint inward or outward 1 complete revolution and tighten the clamp at the loose end of the tie rod.
6. Rotate the entire tie-rod assembly the same direction (inward or outward) 1 complete revolution and tighten the clamp at the connected end of the tie rod.
7. Install the ball joint in the axle-case support, tighten the nut finger-tight, and measure the toe-in.
8. Repeat procedure if necessary.
9. Tighten the nut and install a new cotter pin when the adjustment is correct.
10. Check the opposite tie-rod and repeat the procedure if necessary.

Cooling System Maintenance

Cooling System Safety

- Swallowing engine coolant can cause poisoning; keep out of reach from children and pets.
- Discharge of hot, pressurized coolant or touching a hot radiator and surrounding parts can cause severe burns.
 - Always allow the engine to cool at least 15 minutes before removing the radiator cap.
 - Use a rag when opening the radiator cap, and open the cap slowly to allow steam to escape.
- Do not operate the machine without the covers in place.
- Keep your fingers, hands and clothing clear of rotating fan and drive belt.

Checking the Cooling System

Service Interval: Before each use or daily

Coolant specification: 50/50 mixture of water and ethylene glycol antifreeze

Cooling system capacity: 8.5 L (9 US qt).

▲ DANGER

The rotating fans and drive belts can cause personal injury.

- **Do not operate the machine without the guards in place.**
 - **Keep your fingers, hands, and clothing clear of the rotating fan and drive belt.**
 - **Shut off the engine and remove the key before performing maintenance.**
1. Park the machine on a level surface, engage the parking brake, lower the cutting units, shut off the engine, and remove the key.
 2. Carefully remove the radiator cap.

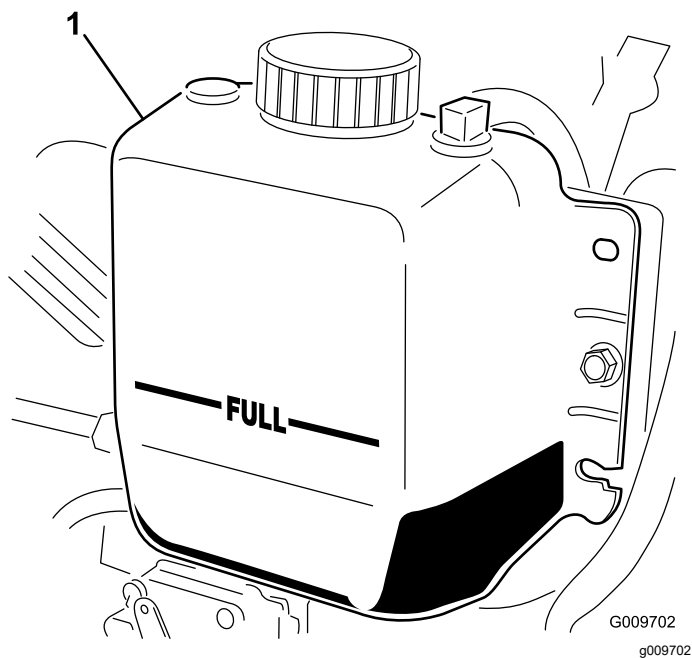

Figure 77

1. Expansion tank

3. Check the coolant level in the radiator. The radiator should be filled to the top of the filler neck and the expansion tank filled to the FULL mark (Figure 77).
4. If the coolant is low, add a 50/50 mixture of water and ethylene glycol anti-freeze. Do not use water only or alcohol/methanol based coolants.
5. Install the radiator cap and expansion-tank cap.

Cleaning the Cooling System

Service Interval: Before each use or daily—Remove debris from the engine area, oil cooler, and radiator (clean them more frequently in dirty conditions).

This machine is equipped with a hydraulically driven fan drive system that automatically (or manually) reverses to reduce oil cooler/radiator and screen debris buildup. While this feature can help reduce the time required to clean oil cooler/radiator, it does not eliminate the need for routine cleaning. Periodic cleaning and inspection of the radiator/cooler is still required.

1. Park the machine on a level surface, engage the parking brake, lower the cutting units, shut off the engine, and remove the key.
 2. Allow the machine to cool down; refer to [Maintenance Safety \(page 43\)](#) and [Cooling System Safety \(page 61\)](#).
 3. Unlatch and swing open the rear screen (Figure 78).
- Note:** To remove the screen, lift it off the hinge pins.
4. Clean the screen thoroughly of all debris.

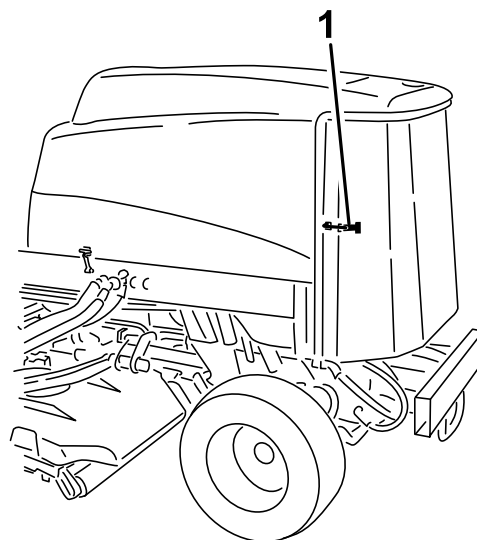

Figure 78

1. Rear-screen latch

5. Thoroughly clean both sides of the oil cooler and the radiator with compressed air (Figure 79).

Note: Start from the front and blow the debris out toward the back. Then clean from the back side and blow toward the front. Repeat procedure several times until you remove all chaff and debris.

Brake Maintenance

Adjusting the Service Brakes

Adjust the service brakes when there is more than 25 mm (1 inch) of free travel of the brake pedal, or when the brakes do not work effectively. Free travel is the distance the brake pedal moves before you feel braking resistance.

1. Park the machine on a level surface, engage the parking brake, lower the cutting units, shut off the engine, and remove the key.
2. Release the locking latch from the brake pedals so that both pedals work independently of each other.
3. To reduce free travel of the brake pedals, tighten the brakes as follows:
 - A. Loosen the front nut on the threaded end of the brake cable (Figure 80).

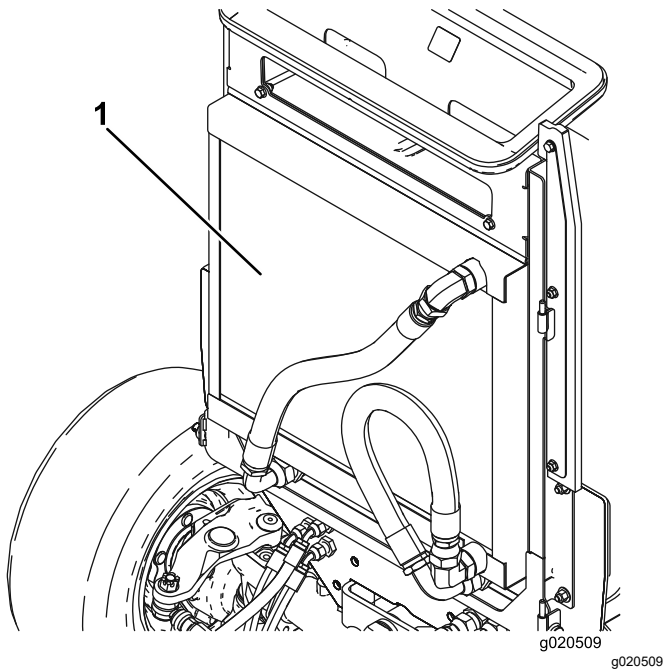

Figure 79

1. Oil cooler/radiator

Important: Cleaning the oil cooler/radiator with water promotes premature corrosion damage to components and compacts debris.

6. Close the rear screen and secure it with the latch.

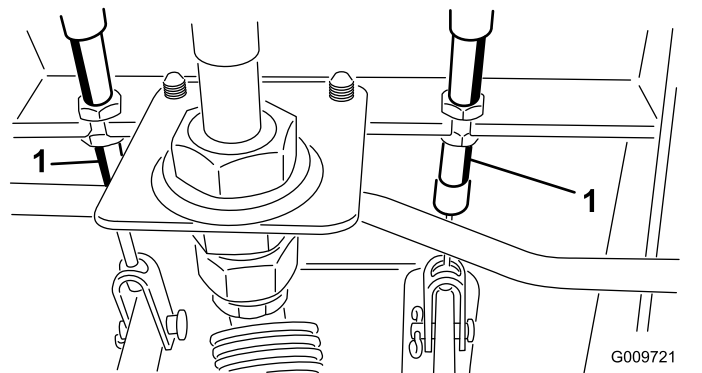

Figure 80

1. Brake cable

- B. Tighten the rear nut to move the cable rearward until the brake pedals have 13 to 25 mm (1/2 to 1 inch) of free travel.
- C. Tighten the front nuts after the brakes are adjusted correctly.

Belt Maintenance

Servicing the Alternator Belt

Service Interval: Every 100 hours

Proper tension of the belt allows 10 mm (3/8 inch) of deflection when a force of 4.5 kg (10 lb) is applied on the belt midway between the pulleys.

If the deflection is not 10 mm (3/8 inch), loosen the alternator-mounting bolts (Figure 81).

Note: Increase or decrease the alternator-belt tension and tighten the bolts. Check the deflection of the belt again to ensure that the tension is correct.

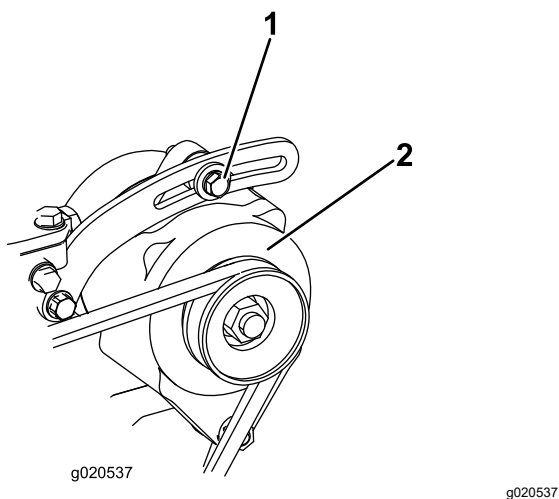

Figure 81

1. Mounting bolt

2. Alternator

Hydraulic System Maintenance

Hydraulic System Safety

- Seek immediate medical attention if fluid is injected into skin. Injected fluid must be surgically removed within a few hours by a doctor.
- Ensure that all hydraulic-fluid hoses and lines are in good condition and all hydraulic connections and fittings are tight before applying pressure to the hydraulic system.
- Keep your body and hands away from pinhole leaks or nozzles that eject high-pressure hydraulic fluid.
- Use cardboard or paper to find hydraulic leaks.
- Safely relieve all pressure in the hydraulic system before performing any work on the hydraulic system.

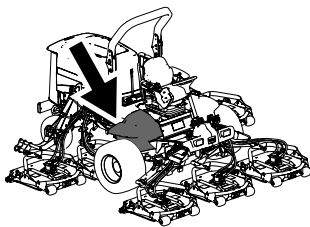

g198718

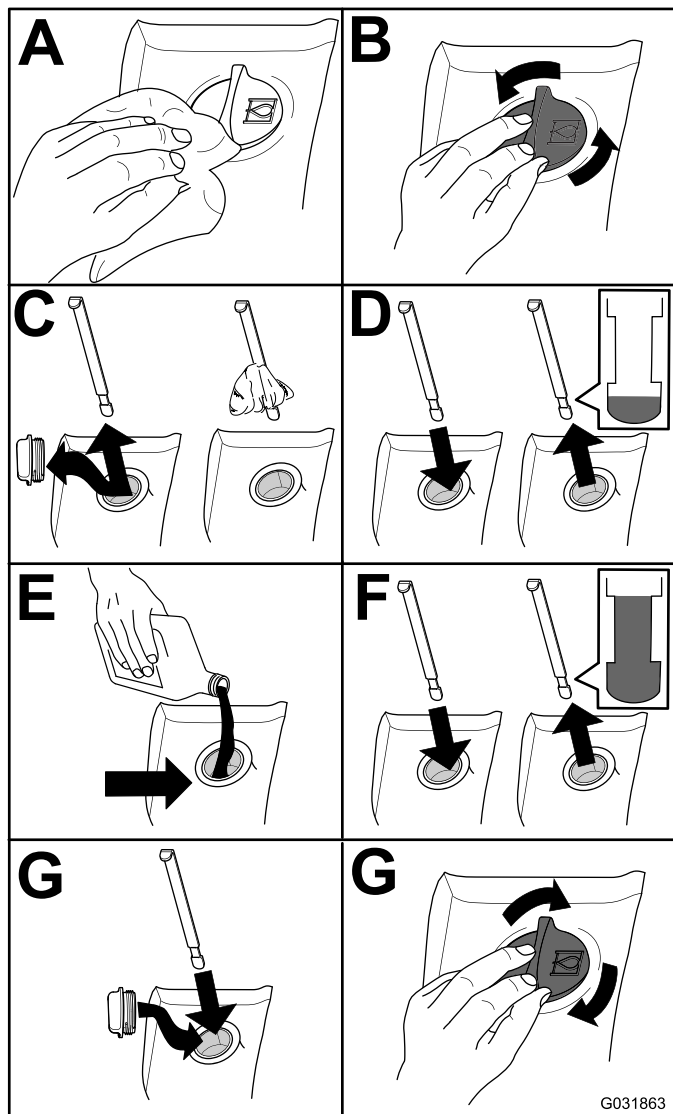

G031863

g031863

Figure 82

Changing the Hydraulic Fluid

Service Interval: Every 2,000 hours—**If you are using the recommended hydraulic fluid**, change the hydraulic fluid.

Every 800 hours—**If you are not using the recommended hydraulic fluid or have ever filled the reservoir with an alternative fluid**, change the hydraulic fluid.

Hydraulic Fluid Capacity: 28.4 L (7.50 US gallons)

If the fluid becomes contaminated, contact your authorized Toro distributor, because the system must be flushed. Contaminated fluid looks milky or black when compared to clean oil.

1. Park the machine on a level surface, engage the parking brake, lower the cutting units, shut off the engine, and remove the key.
2. Raise the hood.
3. Disconnect the case return line from the bottom of the reservoir and let the hydraulic fluid flow into a large drain pan.
4. Install the hose when the hydraulic fluid stops draining.
5. Fill the reservoir with hydraulic fluid; refer to [Checking the Hydraulic-Fluid Level \(page 65\)](#).
Important: Use only the hydraulic fluids specified. Other fluids could cause system damage.
6. Install the reservoir cap.
7. Turn the key in the key switch to the ON position to start the engine. Use all the hydraulic controls to distribute hydraulic fluid throughout the system, and check for leaks.
8. Turn the key in the key switch to the OFF position.
9. Check the fluid level and add enough to raise level the level to the FULL mark on the dipstick. **Do not overfill.**

Replacing the Hydraulic Filters

Service Interval: Every 1,000 hours—**If you are using the recommended hydraulic fluid**, replace the hydraulic filter (sooner if the service interval indicator is in the red zone).

Every 800 hours—**If you are not using the recommended hydraulic fluid or have ever filled the reservoir with an alternative fluid**, replace the hydraulic filter (sooner if the service interval indicator is in the red zone).

Use Toro replacement filters Part No. 94-2621 for the rear (cutting units) of the machine and Part No. 75-1310 for the front (charge) of the machine.

Important: Using another filter may void the warranty on some components.

1. Tilt the operator's seat to access the mower-pressure filter; refer to [Accessing the Hydraulic Lift Compartment \(page 47\)](#)

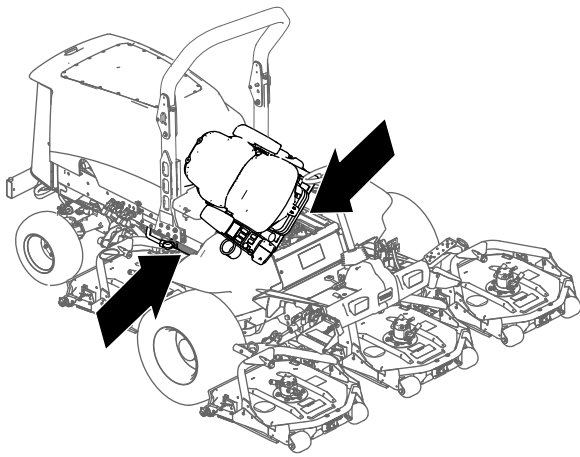
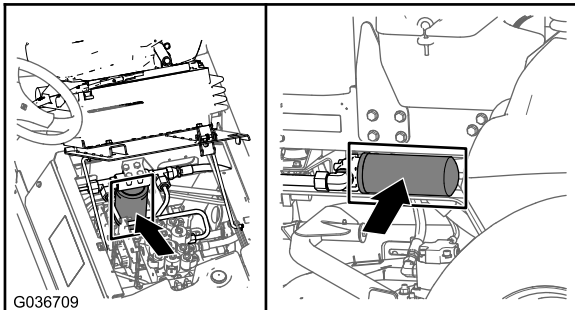

Figure 83

g201858

3. Lower and secure the operator's seat.
4. Replace the return filter at the right side of the machine (Figure 84).
5. Start the engine and let it run for about 2 minutes to purge air from the system. Shut off the engine and check for leaks.

2. Replace the charge hydraulic filter at the hydraulic lift compartment as shown in Figure 84.



G036709

g036709

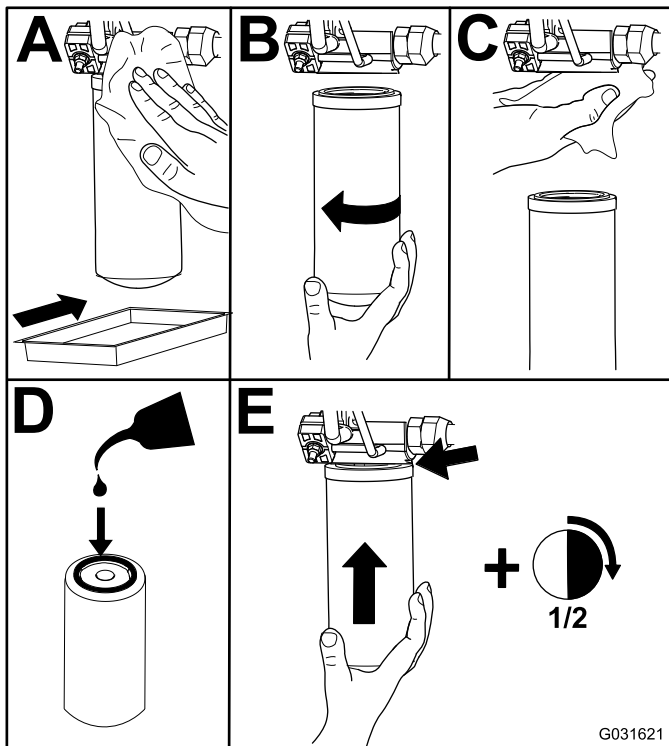

G031621

g031621

Figure 84

Checking the Hydraulic Lines and Hoses

Service Interval: Before each use or daily

Every 2 years

Inspect the hydraulic lines and hoses daily for leaks, kinked lines, loose mounting supports, wear, loose fittings, weather deterioration, and chemical deterioration. Make all necessary repairs before operating the machine.

⚠ WARNING

Hydraulic fluid escaping under pressure can penetrate skin and cause injury.

- Seek immediate medical help if fluid is injected into skin.
- Make sure that all hydraulic-fluid hoses and lines are in good condition and all hydraulic connections and fittings are tight before applying pressure to the hydraulic system.
- Keep your body and hands away from pinhole leaks or nozzles that eject high-pressure hydraulic fluid.
- Use cardboard or paper to find hydraulic leaks.
- Safely relieve all pressure in the hydraulic system before performing any work on the hydraulic system.

Cutting Unit Maintenance

Removing the Cutting Units

1. Park the machine on a level surface, engage the parking brake, lower the cutting units, shut off the engine, and remove the key.
2. Disconnect and remove the hydraulic motor from the cutting unit (Figure 85). Cover the top of the spindle to prevent contamination.

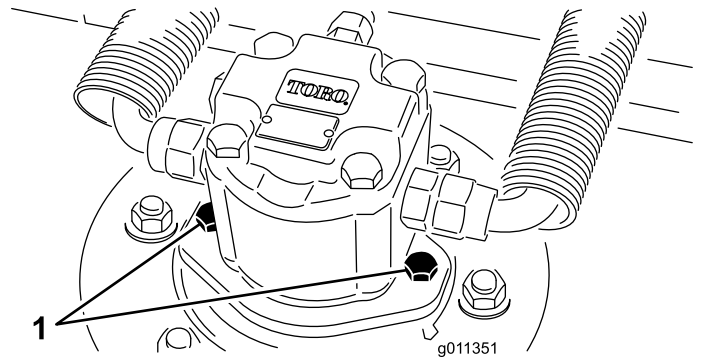

Figure 85

1. Motor-mounting screws

3. Remove the lynch pin (for Groundsmaster 4500 machines) or retaining nut (for Groundsmaster 4700 machines) securing the cutting unit-carrier frame to the lift-arm pivot pin (Figure 86).

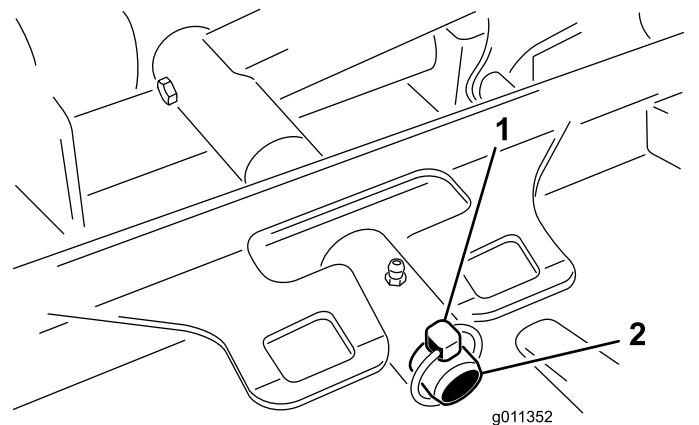

Figure 86

1. Lynch pin
2. Lift-arm pivot pin

4. Roll the cutting unit away from the machine.

Installing the Cutting Units

1. Move the cutting unit into position in front of the machine.
2. Slide the cutting unit-carrier frame onto the lift-arm-pivot pin (Figure 86). Secure the cutting unit to the pin with the lynch pin (for Groundsmaster 4500 machines) or retaining nut (for Groundsmaster 4700 machines).
3. Install the hydraulic motor to the cutting unit (Figure 85). Make sure that the O-ring is in position and not damaged.
4. Grease the spindle.

Servicing the Front Roller

Inspect the front roller for wear, excess wobble, or binding. Service or replace the roller or components if any of these conditions exist.

Disassembling the Front Roller

1. Remove the roller-mounting bolt (Figure 87).
2. Insert a punch through the end of the roller housing and drive the opposite bearing out by alternating taps to the opposite side of inner bearing race. There should be a 1.5 mm (0.060 inch) lip of inner race exposed.

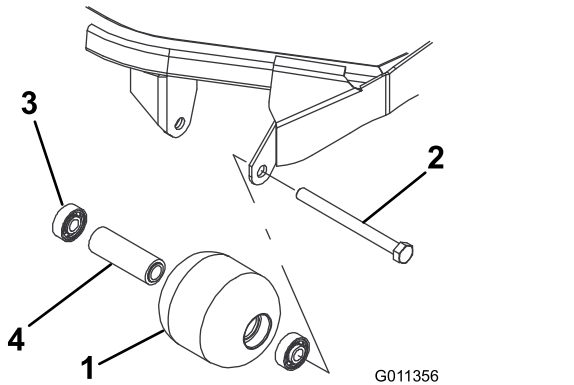

Figure 87

- | | |
|------------------|-------------------|
| 1. Front roller | 3. Bearing |
| 2. Mounting bolt | 4. Bearing spacer |

3. Push the second bearing out in press.
4. Inspect the roller housing, bearings, and bearing spacer for damage (Figure 87). Replace any damaged components and assemble them.

Assembling the Front Roller

1. Press the first bearing into the roller housing (Figure 87). Press on the outer race only or equally on the inner and outer race.
 2. Insert the spacer (Figure 87).
 3. Press the second bearing into the roller housing (Figure 87). Pressing equally on the inner and outer race until the inner race contacts the spacer.
 4. Install the roller assembly into the cutting-unit frame.
 5. Verify that there is no more than a 1.5 mm (0.060 inch) gap between roller assembly and the roller mount brackets of the cutting-unit frame. If there is a gap over 1.5 mm (0.060 inch), install enough 5/8-inch diameter washers to take up the slop.
- Important: Securing the roller assembly with a gap larger than 1.5 mm (0.060 inch) creates a side load on the bearing and can lead to premature bearing failure**
6. Torque the mounting bolt to 108 N·m (80 ft-lb).

Blade Maintenance

Blade Safety

- Inspect the blade periodically for wear or damage.
- Use care when checking the blades. Wrap the blades or wear gloves, and use caution when servicing the blades. Only replace or sharpen the blades; never straighten or weld them.
- On multi-bladed machines, take care as rotating one blade can cause other blades to rotate.

Servicing the Blade Plane

The cutting unit comes from the factory preset at 5 cm (2 inches) height of cut and blade rake of 7.9 mm (0.310 inch). The left and right heights are also preset to within ± 0.7 mm (0.030 inch) of the other.

The cutting unit is designed to withstand blade impacts without deformation of the chamber. If the blade strikes a solid object, inspect the blade for damage and the blade plane for accuracy.

Inspecting the Blade Plane

1. Remove the hydraulic motor from the cutting unit and remove the cutting unit from the machine.
2. Use a hoist (or minimum of 2 people) and place the cutting unit on a flat table.
3. Mark 1 end of the blade with a paint pen or marker. Use this end of the blade to check all heights.
4. Position the cutting edge of the marked end of the blade at 12 o'clock (straight ahead in the direction of mowing) (Figure 88) and measure height from table to cutting edge of blade.

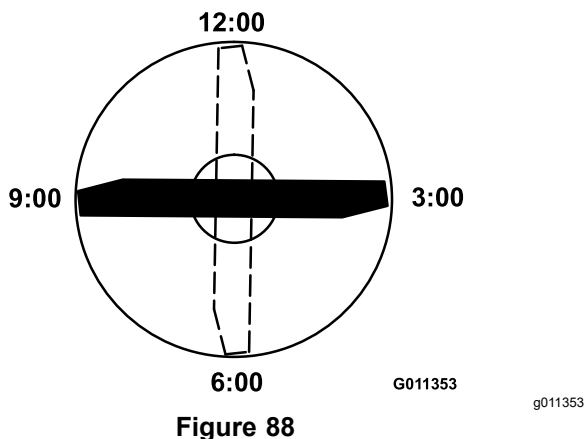

5. Rotate the marked end of the blade to the 3 and 9 o'clock positions (Figure 88) and measure the heights.

6. Compare the 12 o'clock measured height to the height-of-cut setting. It should be within 0.7 mm (0.030 inch). The 3 and 9 o'clock heights should be 1.6 to 6.0 mm (0.060 to 0.240 inch) higher than the 12 o'clock setting and within 2.2 mm (0.090 inch) of each other.

If any of these measurements are not within specification, proceed to [Adjusting the Blade Plane](#) (page 70).

Adjusting the Blade Plane

Start with the front adjustment (change 1 bracket at a time).

1. Remove the height-of-cut bracket, (front, left, or right) from the cutting-unit frame (Figure 89).
2. Insert 1.5 mm (0.060 inch) shims and/or 0.7 mm (0.030 inch) shims between the cutting-unit frame and bracket to achieve the desired height setting (Figure 89).

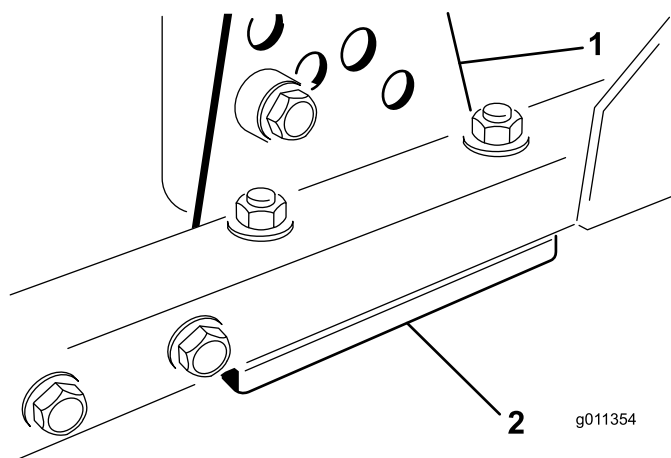

Figure 89

1. Height-of-cut bracket
2. Shims

3. Install the height-of-cut bracket to the cutting-unit frame with the remaining shims assembled below the height-of-cut bracket.
 4. Secure the socket-head bolt/spacer and flange nut.
- Note:** Socket-head bolt/spacer are held together with thread-locking adhesive to prevent the spacer from falling inside the cutting-unit frame.
5. Verify the 12 o'clock height and adjust if needed.
 6. Determine if only 1 or both (right and left) height-of-cut brackets need to be adjusted.

Note: If the 3 or 9 o'clock side is 1.6 to 6.0 mm (0.060 to 0.240 inch) higher than the new front height then no adjustment is needed for that

side. Adjust the other side to within ± 2.2 mm (0.090 inch) of the correct side.

- Adjust the right and/or left height-of-cut brackets by repeating steps 1 through 4.
- Secure the carriage bolts and flange nuts.
- Verify the 12, 3, and 9 o'clock heights.

Removing and Installing the Cutting-Unit Blade(s)

Replace the blade if it hits a solid object, is out of balance, or is bent. Always use genuine Toro replacement blades to ensure safety and optimum performance.

- Park the machine on a level surface, raise the cutting unit to the transport position, engage the parking brake, shut off the engine, and remove the key.

Note: Block or lock the cutting unit to prevent it from accidentally falling.

- Grasp the end of the blade using a rag or thickly-padded glove.
- Remove the blade bolt, anti-scalp cup, and blade from the spindle shaft (Figure 90).

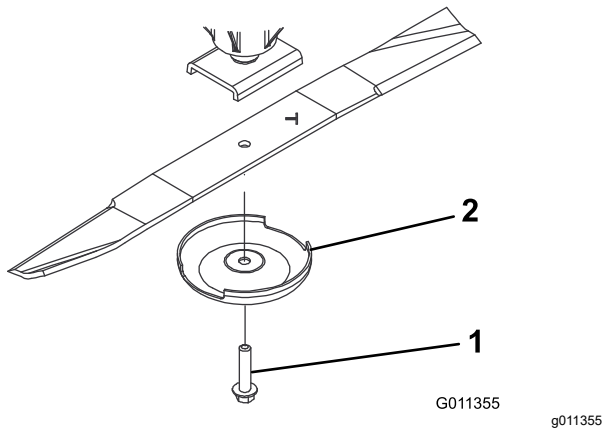

Figure 90

- Blade bolt
- Anti-scalp cup

- Install the blade, anti-scalp cup, and blade bolt and tighten the blade bolt to 115 to 149 N·m (85 to 110 ft-lb).

Important: The curved part of the blade must be pointing toward the inside of the cutting unit to ensure proper cutting.

Note: After striking a foreign object, torque all spindle-pulley nuts to 115 to 149 N·m (85 to 110 ft-lb).

Inspecting and Sharpening the Cutting Unit Blade(s)

Both cutting edges and the sail, which is the turned-up portion opposite of the cutting edge, contribute to a good quality of cut. The sail is important because it lifts the grass up straight, thereby producing an even cut. However, the sail gradually wears down during operation. As the sail wears down, the quality of cut degrades, although the cutting edges are sharp. The cutting edge of the blade must be sharp so that the grass is cut rather than torn. A dull cutting edge is evident when the tips of the grass appear brown and shredded. Sharpen the cutting edges to correct this condition.

- Park the machine on a level surface, raise the cutting unit, engage the parking brake, put the traction pedal in NEUTRAL, put the PTO lever in the OFF position, shut off the engine, and remove the key from the ignition.
- Examine the cutting ends of the blade carefully, especially where the flat and curved parts of the blade meet (Figure 91).

Note: Because sand and abrasive material can wear away the metal that connects the flat and curved parts of the blade, check the blade before using the mower. If the blade is worn (Figure 91), replace it.

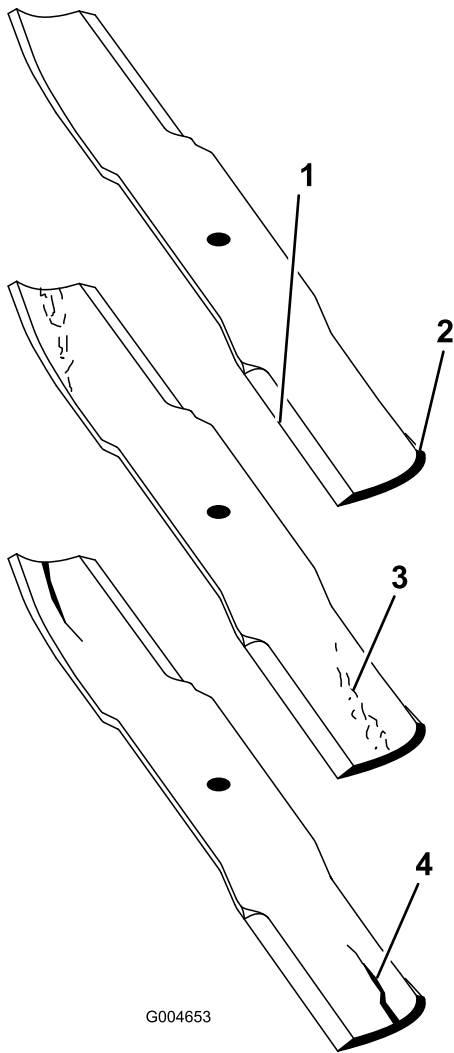

G004653

g004653

Figure 91

- | | |
|-----------------|----------------------|
| 1. Cutting edge | 3. Wear/slot forming |
| 2. Curved area | 4. Crack |

-
3. Examine the cutting edges of all of the blades and sharpen the cutting edges if they are dull or nicked (Figure 92).

Note: Sharpen only the top of the cutting edge and maintain the original cutting angle to ensure sharpness (Figure 92). The blade remains balanced if you remove the same amount of metal from both cutting edges.

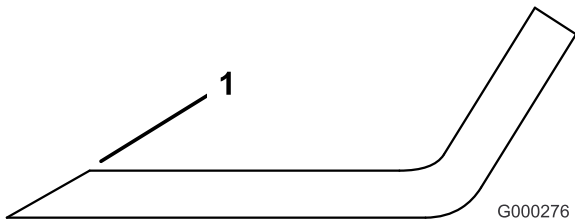

G000276

g000276

Figure 92

1. Sharpen at the original angle.
-

Note: Remove the blades and sharpen them on a grinder. After sharpening the cutting edges, install the blade with the anti-scalp cup and blade bolt; refer to [Removing and Installing the Cutting-Unit Blade\(s\)](#) (page 71).

4. Ensure that the blade is straight and parallel; lay the blade on a level surface and check its ends. The ends of the blade must be slightly lower than the center, and the cutting edge must be lower than the heel of the blade.

Storage

Storage Safety

- Shut off the engine, remove the key, and wait for all movement to stop before you leave the operator's position. Allow the machine to cool before adjusting, servicing, cleaning, or storing it.
- Do not store the machine or fuel container where there is an open flame, spark, or pilot light, such as on a water heater or other appliance.

Preparing the Machine for Storage

Important: Do not use brackish or reclaimed water to clean the machine.

Preparing the Traction Unit

1. Thoroughly clean the traction unit, cutting units, and engine.
2. Check the tire pressure. Inflate all traction unit tires to 83 to 103 kPa (12 to 15 psi).
3. Check all fasteners for looseness and tighten them as necessary.
4. Grease all grease fittings and pivot points. Wipe up any excess lubricant.
5. Lightly sand and use touch-up paint on painted areas that are scratched, chipped, or rusted. Repair any dents in the metal body.
6. Service the battery and cables as follows:
 - A. Remove the battery terminals from the battery posts.

Note: Always disconnect the negative terminal first and the positive last. Always connect the positive terminal first and the negative last.
 - B. Clean the battery, terminals, and posts with a wire brush and baking soda solution.
 - C. Coat the cable terminals and battery posts with Grafo 112X skin-over grease (Part Number 505-47) or petroleum jelly to prevent corrosion.
 - D. Slowly recharge the battery every 60 days for 24 hours to prevent lead sulfation of the battery.

Preparing the Engine

1. Drain the engine oil from the oil pan and replace the drain plug.

2. Remove and discard the oil filter. Install a new oil filter.
3. Refill the oil pan with designated quantity of motor oil.
4. Turn the key in the switch to the ON position, start the engine, and run it at idle speed for approximately 2 minutes.
5. Turn the key in the switch to the OFF position.
6. Thoroughly drain all fuel from the fuel tank, lines, and the fuel filter/water separator assembly.
7. Flush the fuel tank with fresh, clean diesel fuel.
8. Secure all fuel-system fittings.
9. Thoroughly clean and service the air-cleaner assembly.
10. Seal the air-cleaner inlet and the exhaust outlet with weatherproof tape.
11. Check the antifreeze protection and add as needed for expected minimum temperature in your area.

Preparing a Cutting Unit

If the cutting units are separated from the traction unit for any length of time, install a spindle plug in the top of the spindles to protect the spindles from dust and water.

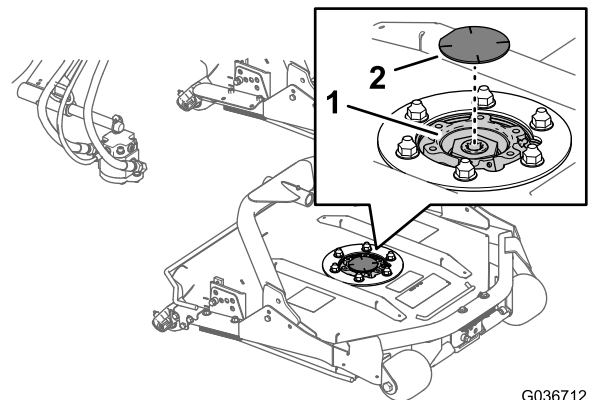

G036712
g036712

Figure 93

1. Spindle sprocket
2. Spindle plug

Notes:

EEA/UK Privacy Notice

Toro's Use of Your Personal Information

The Toro Company ("Toro") respects your privacy. When you purchase our products, we may collect certain personal information about you, either directly from you or through your local Toro company or dealer. Toro uses this information to fulfil contractual obligations - such as to register your warranty, process your warranty claim or to contact you in the event of a product recall - and for legitimate business purposes - such as to gauge customer satisfaction, improve our products or provide you with product information which may be of interest. Toro may share your information with our subsidiaries, affiliates, dealers or other business partners in connection these activities. We may also disclose personal information when required by law or in connection with the sale, purchase or merger of a business. We will never sell your personal information to any other company for marketing purposes.

Retention of your Personal Information

Toro will keep your personal information as long as it is relevant for the above purposes and in accordance with legal requirements. For more information about applicable retention periods please contact legal@toro.com.

Toro's Commitment to Security

Your personal information may be processed in the US or another country which may have less strict data protection laws than your country of residence. Whenever we transfer your information outside of your country of residence, we will take legally required steps to ensure that appropriate safeguards are in place to protect your information and to make sure it is treated securely.

Access and Correction

You may have the right to correct or review your personal data, or object to or restrict the processing of your data. To do so, please contact us by email at legal@toro.com. If you have concerns about the way in which Toro has handled your information, we encourage you to raise this directly with us. Please note that European residents have the right to complain to your Data Protection Authority.



The Toro Warranty

Two-Year or 1,500 Hours Limited Warranty

Conditions and Products Covered

The Toro Company and its affiliate, Toro Warranty Company, pursuant to an agreement between them, jointly warrant your Toro Commercial product ("Product") to be free from defects in materials or workmanship for 2 years or 1,500 operational hours*, whichever occurs first. This warranty is applicable to all products with the exception of Aerators (refer to separate warranty statements for these products). Where a warrantable condition exists, we will repair the Product at no cost to you including diagnostics, labor, parts, and transportation. This warranty begins on the date the Product is delivered to the original retail purchaser.

* Product equipped with an hour meter.

Instructions for Obtaining Warranty Service

You are responsible for notifying the Commercial Products Distributor or Authorized Commercial Products Dealer from whom you purchased the Product as soon as you believe a warrantable condition exists. If you need help locating a Commercial Products Distributor or Authorized Dealer, or if you have questions regarding your warranty rights or responsibilities, you may contact us at:

Toro Commercial Products Service Department
Toro Warranty Company
8111 Lyndale Avenue South
Bloomington, MN 55420-1196
952-888-8801 or 800-952-2740
E-mail: commercial.warranty@toro.com

Owner Responsibilities

As the product owner, you are responsible for required maintenance and adjustments stated in your *Operator's Manual*. Repairs for product issues caused by failure to perform required maintenance and adjustments are not covered under this warranty.

Items and Conditions Not Covered

Not all product failures or malfunctions that occur during the warranty period are defects in materials or workmanship. This warranty does not cover the following:

- Product failures which result from the use of non-Toro replacement parts, or from installation and use of add-on, or modified non-Toro branded accessories and products.
- Product failures which result from failure to perform recommended maintenance and/or adjustments.
- Product failures which result from operating the Product in an abusive, negligent, or reckless manner.
- Parts consumed through use that are not defective. Examples of parts which are consumed, or used up, during normal Product operation include, but are not limited to, brake pads and linings, clutch linings, blades, reels, rollers and bearings (sealed or greasable), bed knives, spark plugs, castor wheels and bearings, tires, filters, belts, and certain sprayer components such as diaphragms, nozzles, flow meters, and check valves.
- Failures caused by outside influence, including, but not limited to, weather, storage practices, contamination, use of unapproved fuels, coolants, lubricants, additives, fertilizers, water, or chemicals.
- Failure or performance issues due to the use of fuels (e.g. gasoline, diesel, or biodiesel) that do not conform to their respective industry standards.
- Normal noise, vibration, wear and tear, and deterioration. Normal "wear and tear" includes, but is not limited to, damage to seats due to wear or abrasion, worn painted surfaces, scratched decals or windows.

Countries Other than the United States or Canada

Customers who have purchased Toro products exported from the United States or Canada should contact their Toro Distributor (Dealer) to obtain guarantee policies for your country, province, or state. If for any reason you are dissatisfied with your Distributor's service or have difficulty obtaining guarantee information, contact your Authorized Toro Service Center.

Parts

Parts scheduled for replacement as required maintenance are warranted for the period of time up to the scheduled replacement time for that part. Parts replaced under this warranty are covered for the duration of the original product warranty and become the property of Toro. Toro will make the final decision whether to repair any existing part or assembly or replace it. Toro may use remanufactured parts for warranty repairs.

Deep Cycle and Lithium-Ion Battery Warranty

Deep cycle and Lithium-Ion batteries have a specified total number of kilowatt-hours they can deliver during their lifetime. Operating, recharging, and maintenance techniques can extend or reduce total battery life. As the batteries in this product are consumed, the amount of useful work between charging intervals will slowly decrease until the battery is completely worn out. Replacement of worn out batteries, due to normal consumption, is the responsibility of the product owner. Note: (Lithium-Ion battery only): Refer to the battery warranty for additional information.

Lifetime Crankshaft Warranty (ProStripe 02657 Model Only)

The ProStripe which is fitted with a genuine Toro Friction Disc and Crank-Safe Blade Brake Clutch (integrated Blade Brake Clutch (BBC) + Friction Disc assembly) as original equipment and used by the original purchaser in accordance with recommended operating and maintenance procedures, are covered by a Lifetime Warranty against engine crankshaft bending. Machines fitted with friction washers, Blade Brake Clutch (BBC) units and other such devices are not covered by the Lifetime Crankshaft Warranty.

Maintenance is at Owner's Expense

Engine tune-up, lubrication, cleaning and polishing, replacement of filters, coolant, and completing recommended maintenance are some of the normal services Toro products require that are at the owner's expense.

General Conditions

Repair by an Authorized Toro Distributor or Dealer is your sole remedy under this warranty.

Neither The Toro Company nor Toro Warranty Company is liable for indirect, incidental or consequential damages in connection with the use of the Toro Products covered by this warranty, including any cost or expense of providing substitute equipment or service during reasonable periods of malfunction or non-use pending completion of repairs under this warranty. Except for the Emissions warranty referenced below, if applicable, there is no other express warranty. All implied warranties of merchantability and fitness for use are limited to the duration of this express warranty.

Some states do not allow exclusions of incidental or consequential damages, or limitations on how long an implied warranty lasts, so the above exclusions and limitations may not apply to you. This warranty gives you specific legal rights, and you may also have other rights which vary from state to state.

Note Regarding Emissions Warranty

The Emissions Control System on your Product may be covered by a separate warranty meeting requirements established by the U.S. Environmental Protection Agency (EPA) and/or the California Air Resources Board (CARB). The hour limitations set forth above do not apply to the Emissions Control System Warranty. Refer to the Engine Emission Control Warranty Statement supplied with your product or contained in the engine manufacturer's documentation.