



**Count on it.**

**Parts Catalog**

**30in Stand-On Aerator**

Model No. 29521—Serial No. 408863720 and Up



# Ordering Replacement Parts

To order replacement parts, please supply the part number, the quantity, and the description of each part desired.

## **Understanding Reference Numbers**

Each identified part in an illustration has a reference number. The reference number for a part also appears in the parts list, along with other information about the part.

This catalog uses two special reference number formats, one to indicate parts in a service assembly and another to indicate the quantity of a given part in an illustration.

## **Service Assembly Reference Numbers**

Parts in service assemblies have reference numbers in the form a:b. The a represents the reference number of the entire service assembly and the b represents a sequential number unique to each part within the service assembly.

For example, a wheel assembly might be identified by reference number 6, the tire by 6:1, the valve by 6:2, and the wheel by 6:3. When you order the assembly identified by reference number 6, you receive all parts identified by reference numbers 6:1, 6:2, and 6:3. However, you may also order any part individually. Reference numbers of this type appear in illustration and in parts lists.

## **Reference Numbers Indicating Quantity**

In an illustration, if a reference number indicates more than one part, the reference number has the form nX y. The n represents the quantity of the part, the X is the multiplication symbol, and the y represents the reference number.

For example, in an illustration, the reference number 2X 37 means that two of the parts identified by reference number 37 are indicated.

# Contents

Main Frame Assembly .....	4
Main Frame Decal Assembly No. 135-5938 .....	6
Caster Wheel and Fork Assembly .....	8
Platform Assembly No. 116-9135 .....	10
Tower Assembly .....	12
Ground Drive Assembly .....	14
Idler Arm Assembly No. 116-9307 .....	16
RH Transaxle Assembly No. 135-1050 .....	18
LH Transaxle Assembly No. 135-1051 .....	20
Axle and Bearing Assembly No. 116-9545 .....	22
Tine Assembly .....	24
RH Tine Wheel Assembly No. 135-2507 .....	26
LH Tine Wheel Assembly No. 135-2510 .....	28
Fuel Assembly .....	30
Motion Control Assembly .....	32
Electrical Assembly .....	34
Auxiliary Hydraulic Assembly .....	36
Hydraulic Pump Assembly No. 116-9129 .....	38
Engine Assembly .....	40



## Main Frame Assembly (continued)

<i>Ref.</i>	<i>Part Number</i>	<i>Qty.</i>	<i>Description</i>	<i>Ref.</i>	<i>Part Number</i>	<i>Qty.</i>	<i>Description</i>
1	135-5938	1	Main Frame ASM	14	3234-40	4	Screw-HF
2		2	Front Caster ASM ●	18	104-8301	6	Nut-HF, NI
3	116-6536-01	1	Weight	19	3256-24	4	Washer-Flat
4	116-9135	1	Platform W/Rocker ASM	21	135-4629	2	Screw-Sems (3/8-16 X 1)
5	116-7300	1	Access Cover ASM	22	614672	2	Screw-Shoulder, HWH
5:2	121-6163	1	Decal-Operation, Tine Ground (CE)	23	1-811010	2	Plug
6	116-8258	1	Muffler Guard ASM	24	3256-6	2	Washer-Flat
6:2	115-2047	2	Decal-Surface, Hot	28	107-1865	2	R-Clamp
8	99-5107	4	Nut-Lock	29	120-4654	2	Screw-HHF
9	126-0015	2	Grommet	30	104-7050	1	Tube-Manual
10	116-6612-01	1	Guard-Chain, RH	31	104-7048	1	Cap-Housing
11	116-6611-01	1	Guard-Chain, LH	33	133-8062	1	Decal-Arrestor, Spark
				35	323-6	4	Screw-HH

● Not serviced separately

# Main Frame Decal Assembly No. 135-5938

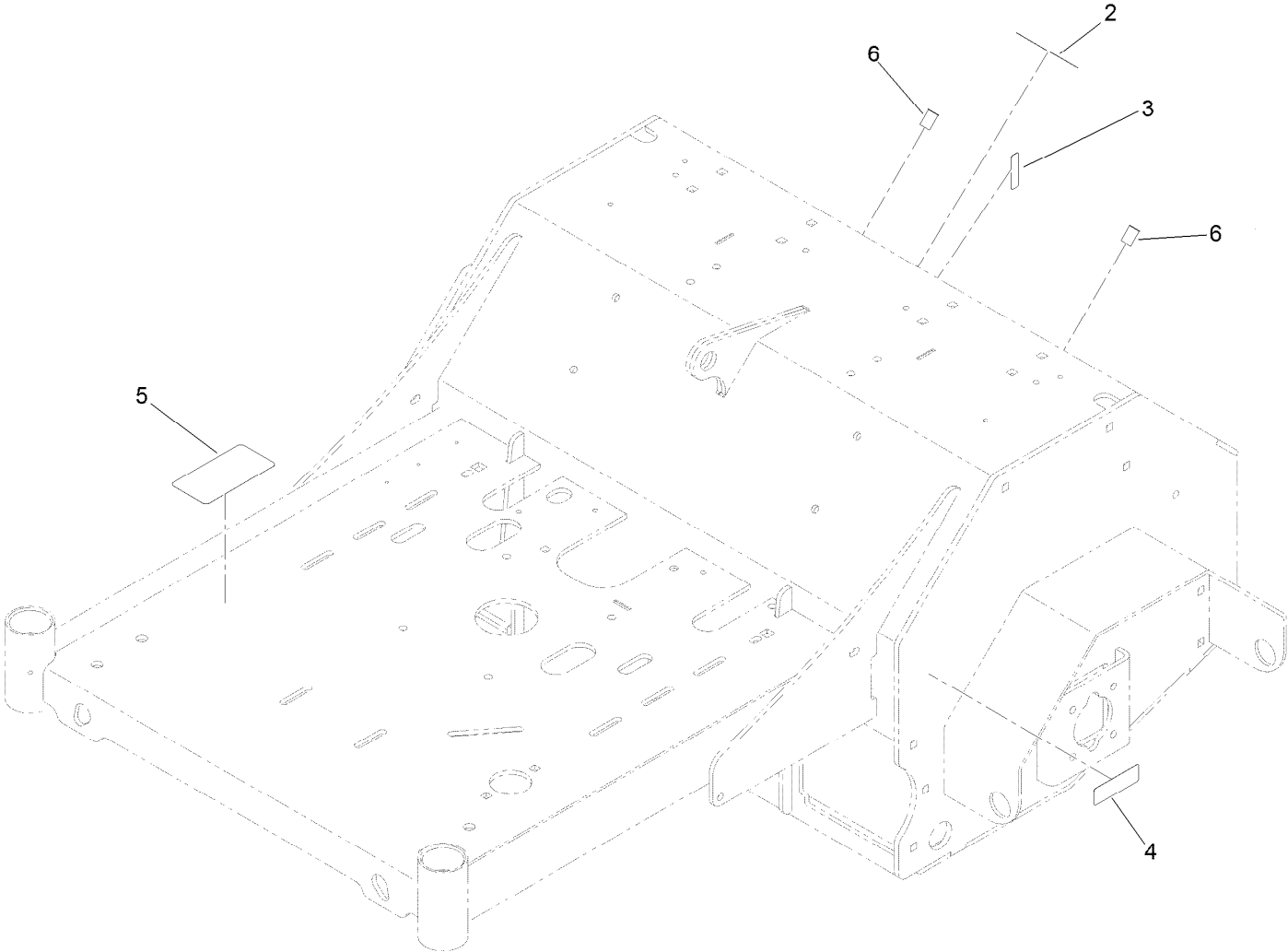

# Main Frame Decal Assembly No. 135-5938 (continued)

<i>Ref.</i>	<i>Part Number</i>	<i>Qty.</i>	<i>Description</i>	<i>Ref.</i>	<i>Part Number</i>	<i>Qty.</i>	<i>Description</i>
2	121-6150	1	Decal-Warning	5	116-9391	1	Decal-Routing, Belt
3	120-9570	1	Decal-Warning	6	32148-10	2	Nut-Clinch
4	121-6161	2	Decal-Danger				

# Caster Wheel and Fork Assembly

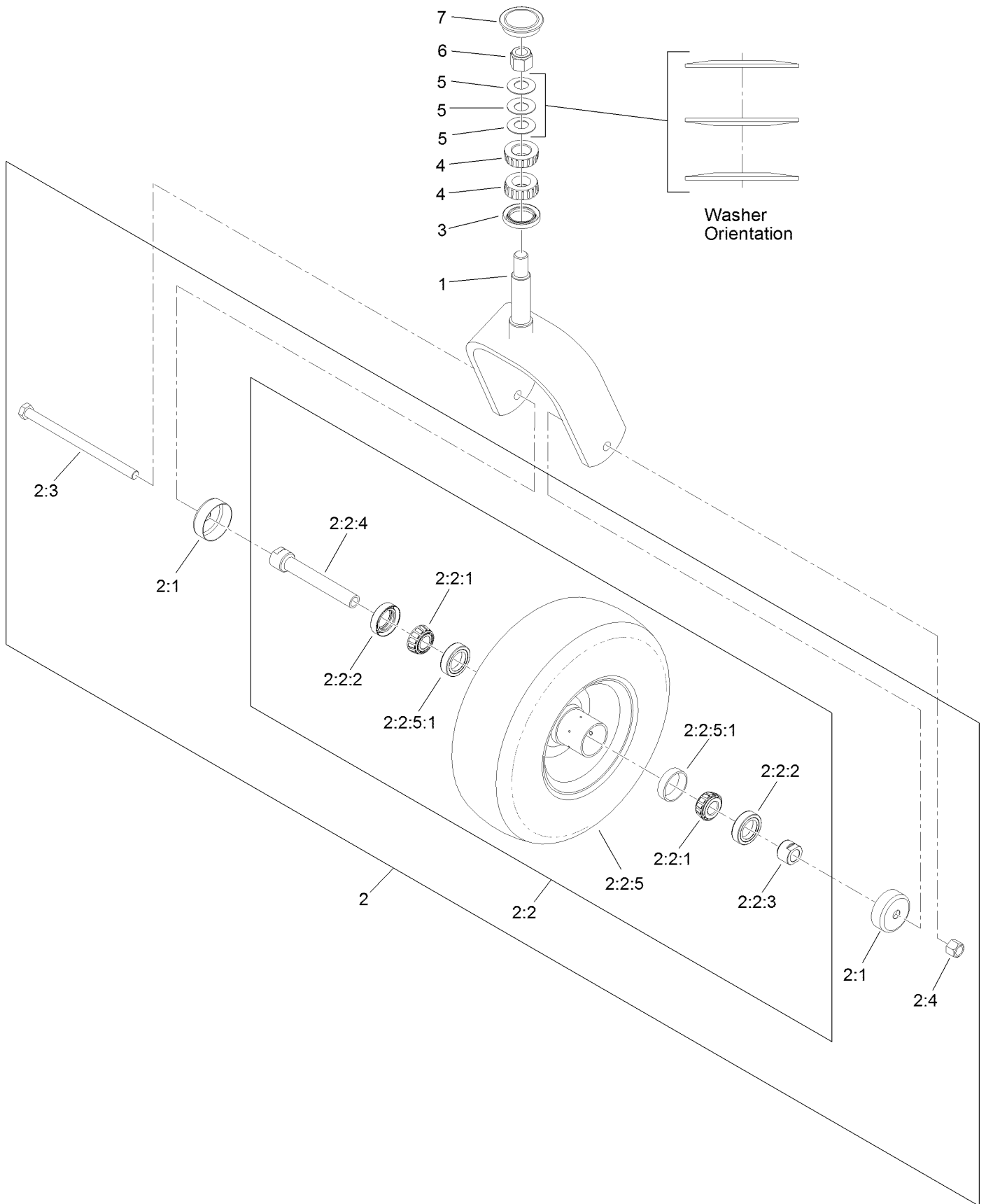



## Caster Wheel and Fork Assembly (continued)

<i>Ref.</i>	<i>Part Number</i>	<i>Qty.</i>	<i>Description</i>	<i>Ref.</i>	<i>Part Number</i>	<i>Qty.</i>	<i>Description</i>
1	116-6704-01	1	Caster	2:2:5:1	1-633584	2	Bearing-Cup
2	127-9531	1	Wheel And Axle ASM	2:3	325-42	1	Screw-HH
2:1	103-2768	2	Guard-Seal	2:4	3296-23	1	Nut-Lock, NI
2:2		1	Wheel And Bearing ASM ●	3	116-5647	1	Seal-Grease
2:2:1	1-633585	2	Bearing-Cone, Taper	4	1-543509	2	Bearing-Roller, Tapered
2:2:2	103-0063	2	Seal-Caster	5	1-633508	3	Washer-Bellville
2:2:3	103-3051	1	Spacer-Nut ■	6	3296-51	1	Nut-Lock, NI
2:2:4	126-5360	1	Axle-Caster	7	103-4882	1	Cap-Grease
2:2:5		1	Wheel And Tire ASM ●				

● Not serviced separately

■ Use Pro-Lock, Nut Type (P/N 1-840022, .5ml tube) on threads.

# Platform Assembly No. 116-9135

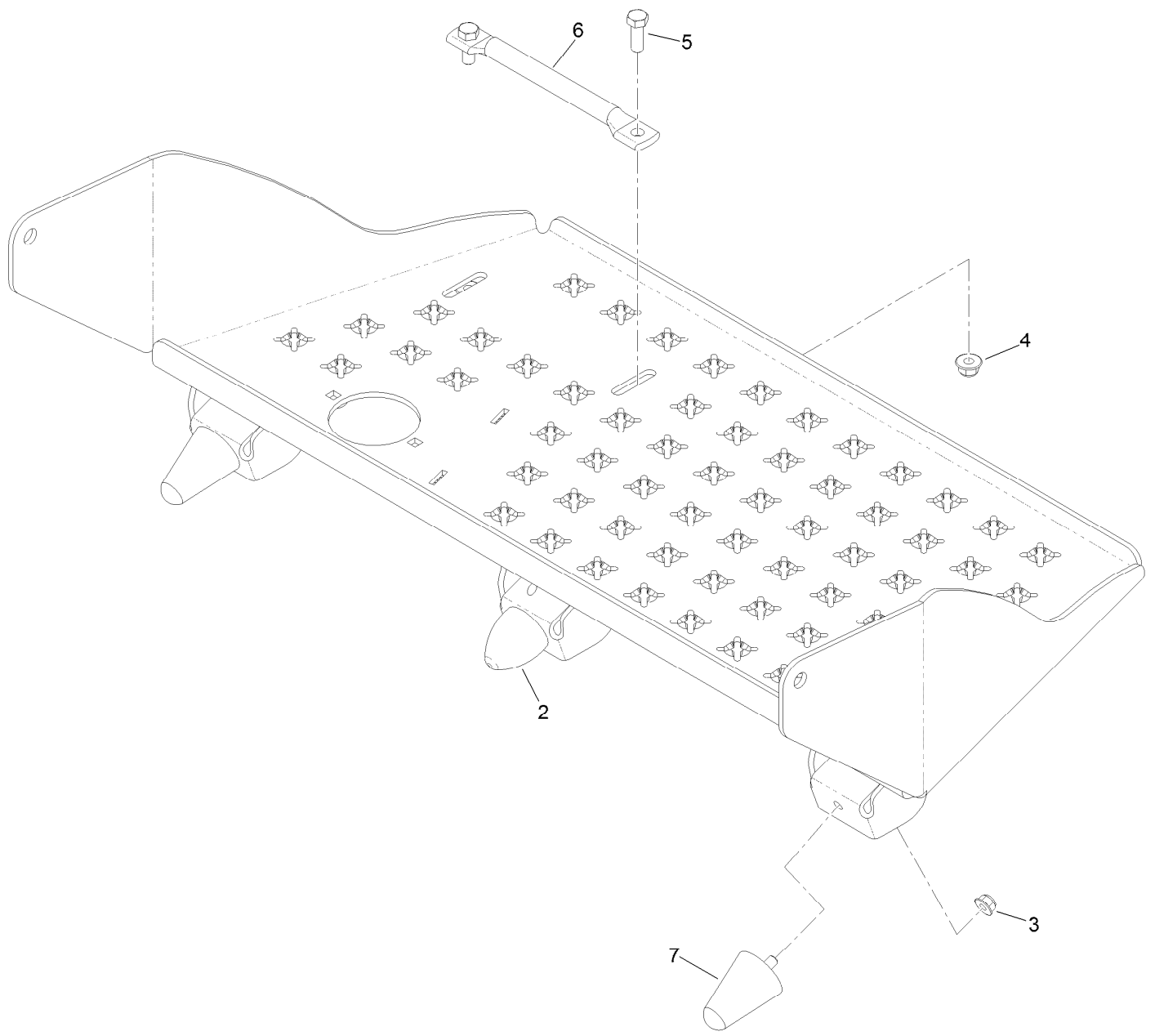

## Platform Assembly No. 116-9135 (continued)

<i>Ref.</i>	<i>Part Number</i>	<i>Qty.</i>	<i>Description</i>
2	114-1926	1	Bumper-Rubber
3	104-8300	3	Nut-HF, NI
4	104-8301	2	Nut-HF, NI

<i>Ref.</i>	<i>Part Number</i>	<i>Qty.</i>	<i>Description</i>
5	323-6	2	Screw-HH
6	116-8950-01	1	Rocker-Pedal, Foot
7	114-1925	2	Bumper-Rubber

# Tower Assembly

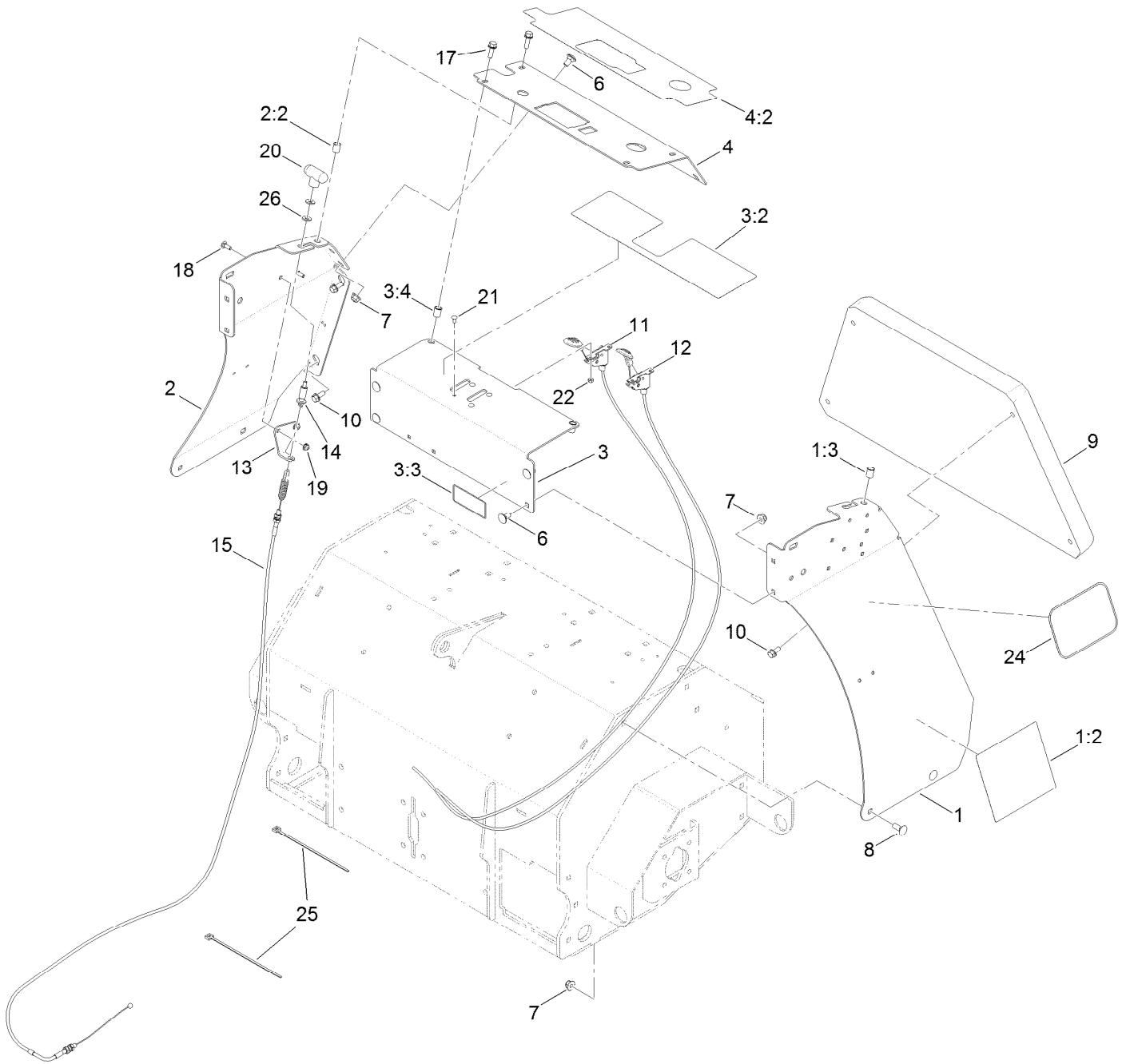

## Tower Assembly (continued)

<i>Ref.</i>	<i>Part Number</i>	<i>Qty.</i>	<i>Description</i>	<i>Ref.</i>	<i>Part Number</i>	<i>Qty.</i>	<i>Description</i>
1	135-5949	1	LH Side Panel ASM	10	3234-5	4	Screw-HHF
1:2	116-9392	1	Decal-Service Aid (CE)	11	109-9147	1	Control-Choke
1:3	32148-7	1	Nut-Clinch	12	109-3958	1	Control-Throttle
2	116-7657	1	RH Side Panel ASM	13	116-6630	1	Bracket-Cable, Brake
2:2	32148-7	1	Nut-Clinch	14	116-7504	1	Link-Cable, Brake
3	135-6293	1	Front Console Plate ASM	15	116-7503	1	Cable-Brake
3:2	121-6164	1	Decal-Warning, Control Panel	17	3234-29	4	Screw-HHF
3:3	121-6162	1	Decal-Warning, Tines	18	3229-1	2	Screw-CARR
3:4	32148-7	2	Nut-Clinch	19	104-7201	2	Nut-Flange, NI
4	135-5951	1	Console ASM	20	116-7607	1	Knob-Tee
4:2	135-5948	1	Decal-Panel, Control	21	1-807513	4	Bolt-CARR
6	3231-1	6	Screw-CARR	22	3296-2	4	Nut-Lock, NI
7	104-8301	10	Nut-HF, NI	24	62-5550	2	Decal
8	3231-2	4	Bolt-CARR	25	3290-378	2	Tie-Cable
9	116-6959	1	Cushion-Black	26	3256-2	2	Washer-Flat

# Ground Drive Assembly

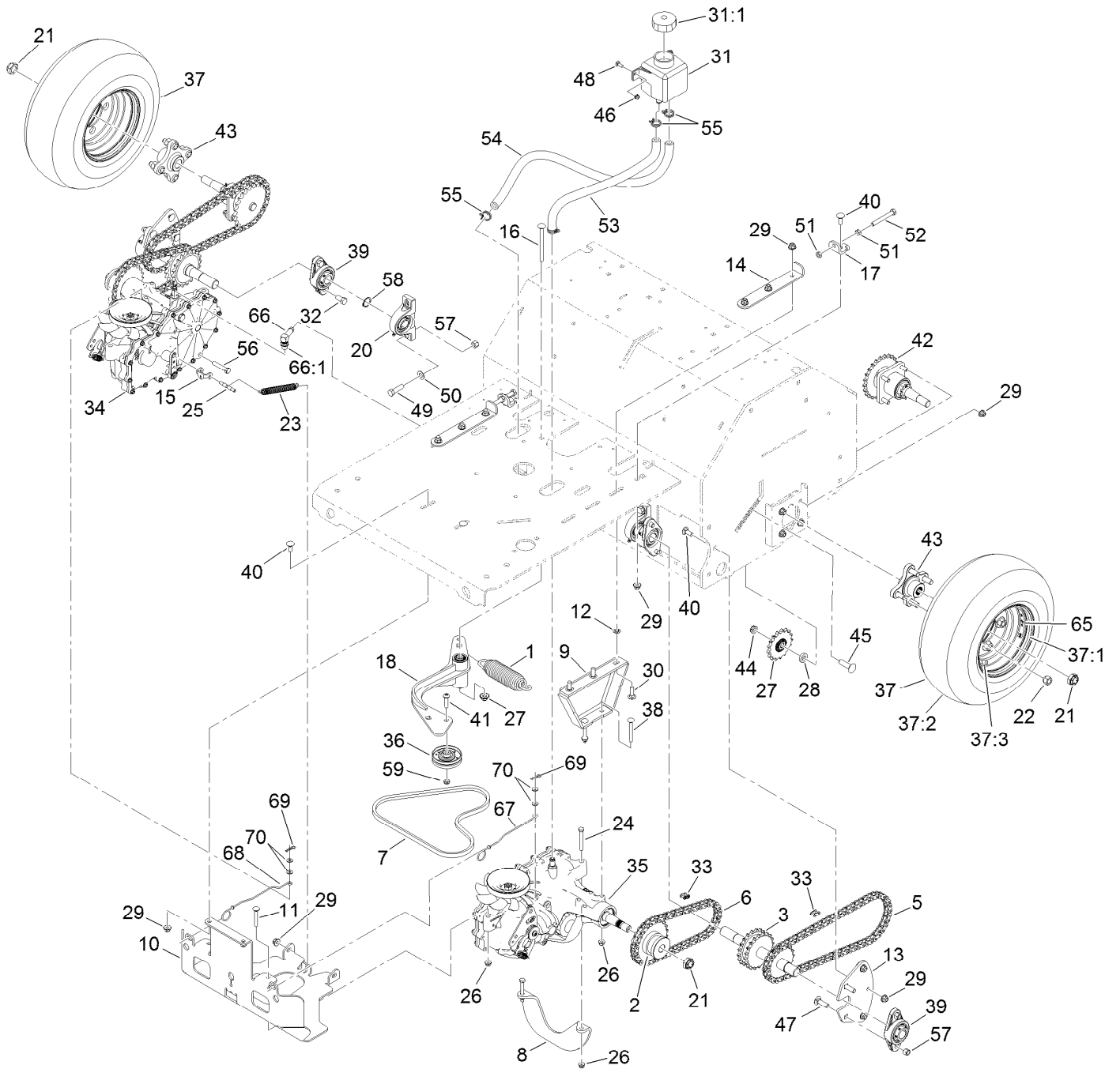

## Ground Drive Assembly (continued)

<i>Ref.</i>	<i>Part Number</i>	<i>Qty.</i>	<i>Description</i>	<i>Ref.</i>	<i>Part Number</i>	<i>Qty.</i>	<i>Description</i>
1	116-6317	1	Spring-Extension	36	116-9715	1	Pulley-Idler
2	116-9305	2	Hub-Drive, Chain	37	126-4267	2	Wheel And Tire ASM
3	126-5625	2	Jackshaft	37:1	126-4266	1	Rim-Gray
5	126-8808	2	Chain-Roller	37:2	116-6978	1	Tire
6	126-8807	2	Chain-Roller	37:3	232-27	1	Stem-Valve
7	116-8874	1	Belt-4L Section	38	3230-9	4	Screw-CARR
8	135-5051-03	1	Brace-Angle	39	116-6777	4	Bearing-Flange, 2 Bolt
9	116-9710-03	2	Mount-Transmission	40	3231-2	10	Bolt-CARR
10	126-5495-03	1	Guard-Transmission	41	116-9927	1	Screw-HSBH
11	3230-7	2	Bolt-CARR	42	116-9545	2	Axle And Bearing ASM
12	107-3154	6	Nut-Push	43	116-3872	2	Hub-Offset
13	116-6596-01	2	Plate-Jackshaft	44	3296-45	2	Nut-Hex
14	116-6619	2	Plate-Adjustment, Transmission	45	3233-14	2	Screw-CARR
15	116-7597	1	Yoke-Brake, Park	46	104-7201	2	Nut-Flange, NI
16	9000779	1	Bolt-CARR	47	3232-3	4	Bolt-CARR
17	116-6723	2	Bracket-Hydro, Adjust	48	3229-1	2	Screw-CARR
18	116-9307	1	Idler Arm ASM	49	324-6	4	Screw-HH
20	116-6756	2	Bearing-Pillow Block	50	3256-25	4	Washer-Flat
21	116-2839	4	Nut-Lock	51	3217-7	4	Nut-Hex
22	242-50	8	Nut-Lug	52	99-8664	2	Screw-HH
23	76-4660	1	Spring-Door	53	116-6775	1	Hose-Hydraulic
24	322-12	2	Screw-HH	54	116-6776	1	Hose-Hydraulic
25	116-7596	1	Pin-Brake, Park	55	109-3322	4	Clamp-Hose
26	104-8300	8	Nut-HF, NI	56	323-10	2	Screw-HH
27	126-9108	2	Sprocket-Idler, 15T	57	3296-48	8	Nut-Hex
28	104-8417	2	Washer	58	32151-29	2	Ring-Retaining
29	104-8301	27	Nut-HF, NI	59	3296-59	1	Nut-Lock, NI
30	3231-25	6	Bolt-CARR	65	126-2054	2	Decal-Hub, Wheel
31	109-2250	1	Tank-HYD	66	109-6449	1	Fitting-Elbow, 90
31:1	109-3320	1	Cap-Reservoir, HYD	66:1	237-42	1	O-Ring
32	135-7810	4	Screw-HH	67	135-0685	1	Rod-Bypass, RH
33	116-6897	4	Link-Connecting	68	135-0683	1	Rod-Bypass, LH
34	135-1050	1	RH Transaxle ASM (W/Pin)	69	1-806003	2	Pin-Cotter
35	135-1051	1	LH Transaxle ASM (W/Pin)	70	119-8952	4	Washer

# Idler Arm Assembly No. 116-9307

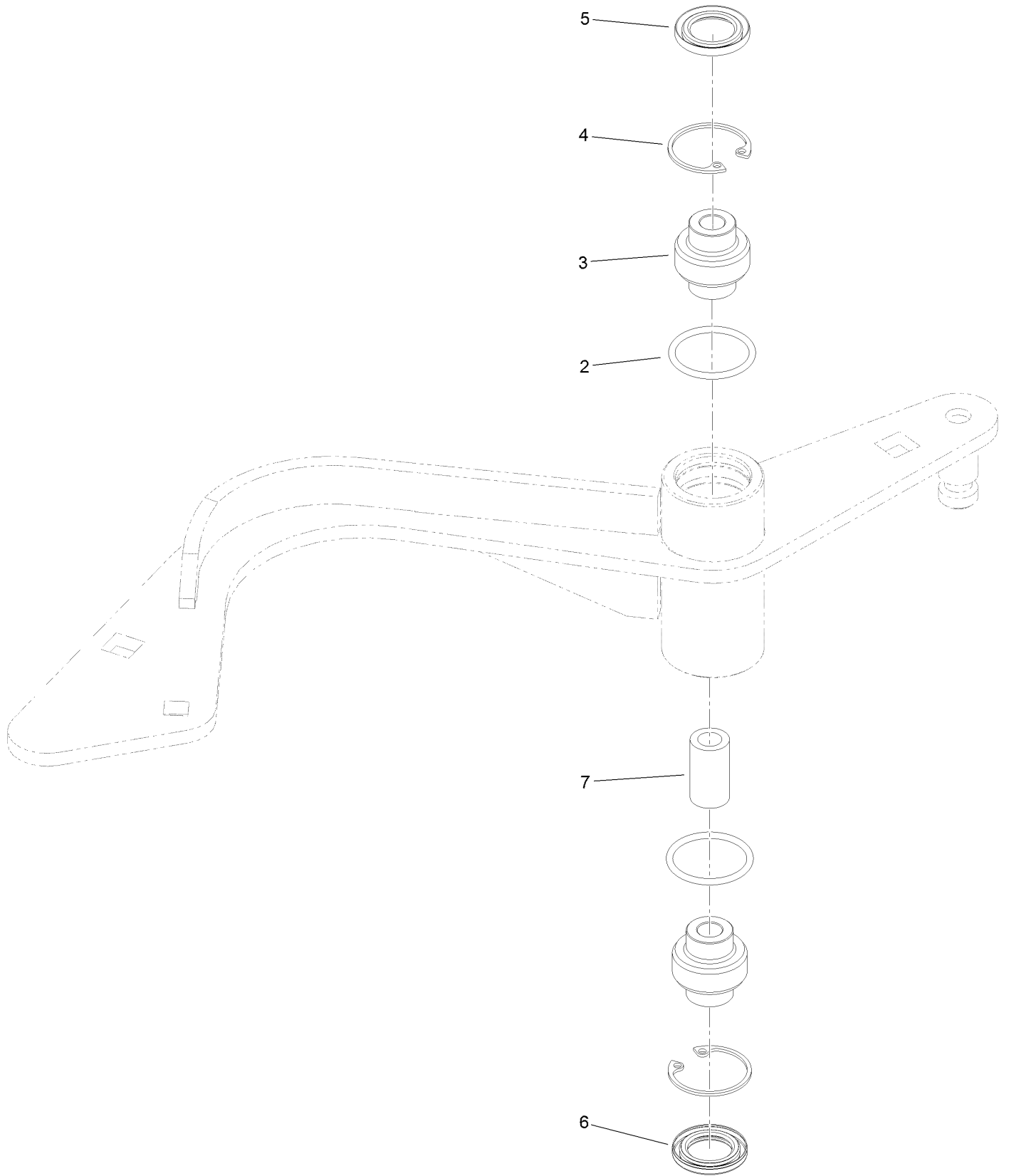



## Idler Arm Assembly No. 116-9307 (continued)

<i>Ref.</i>	<i>Part Number</i>	<i>Qty.</i>	<i>Description</i>	<i>Ref.</i>	<i>Part Number</i>	<i>Qty.</i>	<i>Description</i>
2	106-7159	2	O-Ring	5	103-3506	1	Seal-Lip, Single
3	103-3504	2	Bearing-Spherical	6	103-3505	1	Seal-Lip, Double
4	32120-10	2	Ring-Snap	7	1-603401	1	Spacer

# RH Transaxle Assembly No. 135-1050

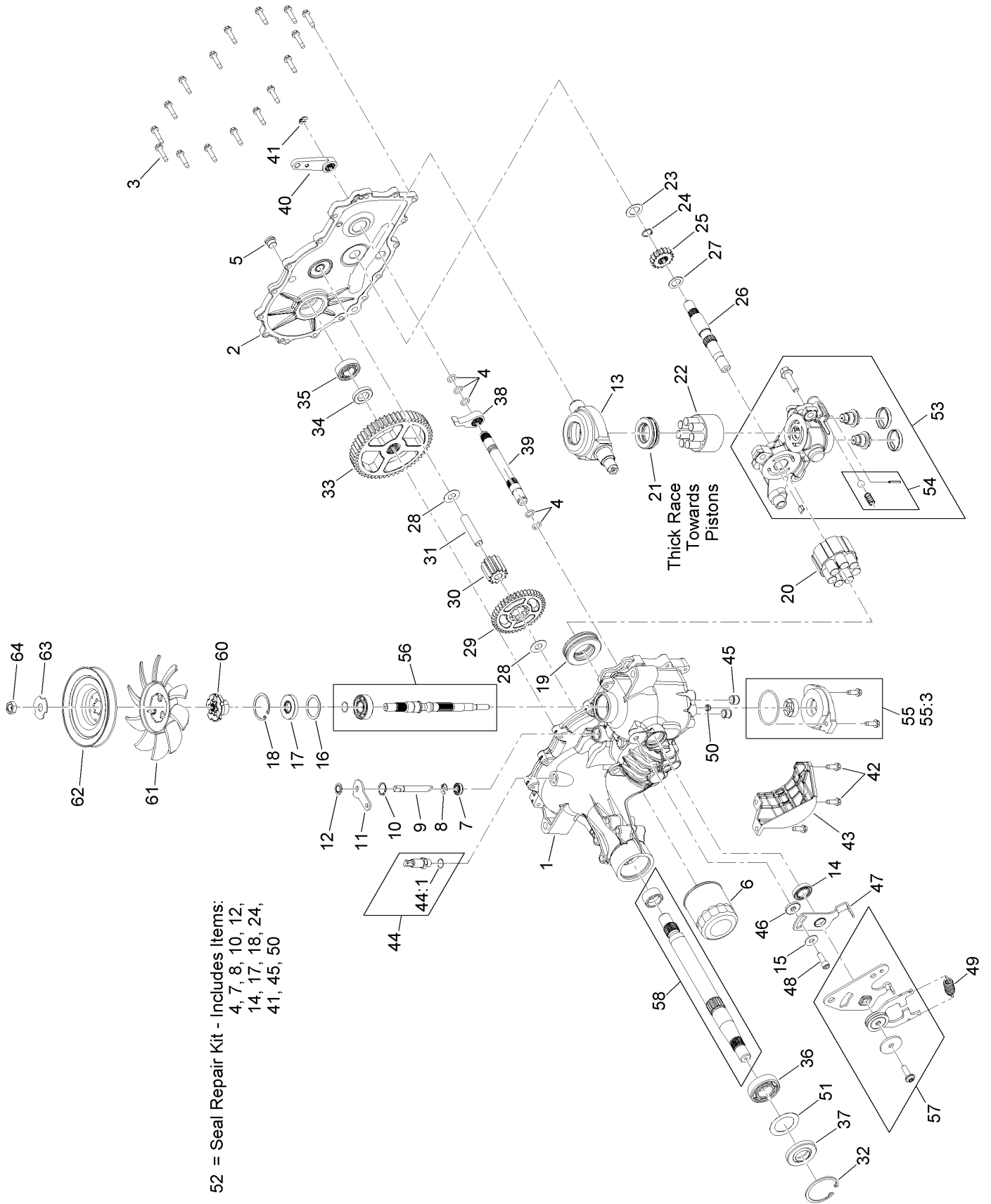

## RH Transaxle Assembly No. 135-1050 (continued)

<i>Ref.</i>	<i>Part Number</i>	<i>Qty.</i>	<i>Description</i>	<i>Ref.</i>	<i>Part Number</i>	<i>Qty.</i>	<i>Description</i>
1	114-1676	1	Main Housing Kit	35	135-1361	1	Bearing-Ball
2	117-5358	1	RH Housing Side Kit	36	130-8477	1	Bearing-Ball
3	117-5359	16	Screw-HHF	37	104-2144	1	Seal
4	114-1678	5	O-Ring	38	114-1697	1	Pawl-Brake
5	135-1140	1	Plug-Straight	39	114-1698	1	Shaft-Brake, Inboard
6	109-3321	1	Element-Oil Filter, HYD	40	125-0021	1	Handle-Brake
7	106-8676	1	Seal-Lip	41	131-0906	1	Ring-Retaining, EXT
8	106-8677	1	Ring-Retaining, External	42	104-2120	3	Screw
9	114-1685	1	Rod-Bypass	43	120-7981	1	Guard-Filter, RH
10	106-8679	1	Ring-Retaining, Internal	44	109-3278	1	Adapter-Straight
11	106-8680	1	Arm-Bypass	44:1	237-42	1	O-Ring
12	106-8681	1	Ring-Retaining, External	45	126-3251	2	Tube-Charge
13	104-5304	1	Swashplate-Trunnion	46	114-8458	1	Spacer
14	104-5313	1	Seal-Lip	47	114-8459	1	Arm-Neutral, Right
15	114-8491	1	Washer	48	106-8682	1	Screw-Sh
16	104-5308	1	Spacer	49	115-8307	1	Spring-Extension
17	104-5310	1	Seal-Lip	50	131-0908	1	Seal-Gerotor
18	104-5309	1	Ring-Retaining	51	121-5745	1	Spacer
19	112-4154	1	Bearing-Thrust	52	109-3537	1	Seal Kit
20	114-1689	1	Motor Cylinder Block Kit	53	120-7982	1	RH Center Section Charge Kit
21	94-6922	1	Bearing-Thrust				
22	110-8561	1	Pump Block ASM	54	114-8464	1	Charge Relief Kit
23	104-5339	1	Washer-Flat	55	114-8465	1	Charge Kit
24	104-5340	1	Ring-Retaining	55:3	109-3540	1	O Ring-Seal
25	126-0788	1	Gear-16T	56	117-5361	1	Input Shaft Kit
26	114-1691	1	Shaft-Motor	57	126-2291	1	Control Arm Kit
27	104-5360	1	Washer	58	114-8470	1	Axle Shaft Kit
28	94-1933	2	Washer	60	116-9705	1	Hub-Pulley
29	125-0000	1	Gear-43T	61	116-9706	1	Fan
30	120-7974	1	Gear-11T	62	116-9707	1	Pulley
31	104-5329	1	Pin-Jackshaft	63	116-9708	1	Washer-Slotted
32	104-2169	1	Ring-Retaining	64	116-9714	1	Nut-HJ
33	114-1694	1	Gear-54T	99	135-3604	1	Brake Shaft Seal Kit ●
34	120-7975	1	Spacer				

● Not illustrated

# LH Transaxle Assembly No. 135-1051

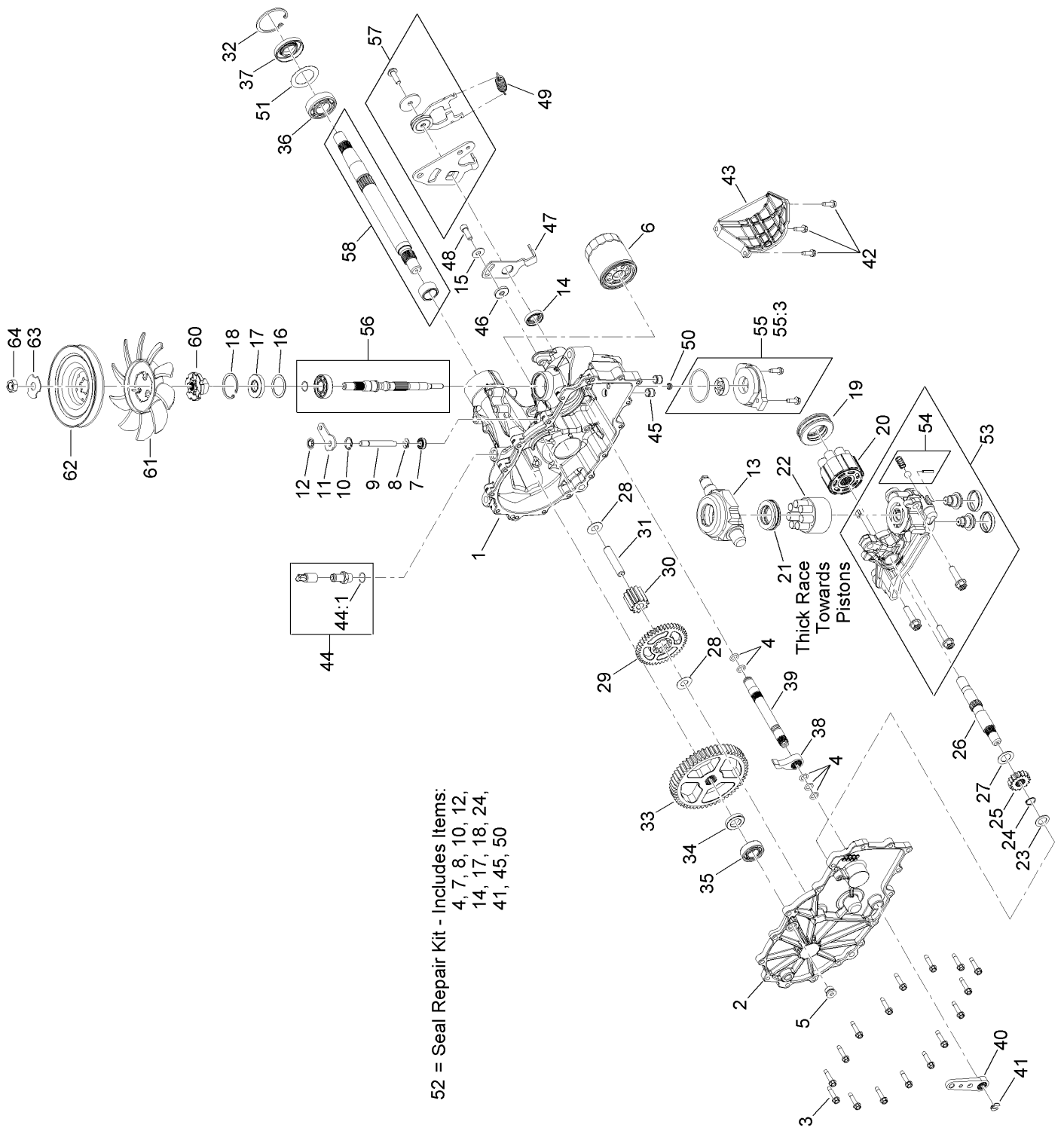

52 = Seal Repair Kit - Includes Items:  
 4, 7, 8, 10, 12,  
 14, 17, 18, 24,  
 41, 45, 50

Thick Race  
 Towards  
 Pistons

# LH Transaxle Assembly No. 135-1051 (continued)

<i>Ref.</i>	<i>Part Number</i>	<i>Qty.</i>	<i>Description</i>	<i>Ref.</i>	<i>Part Number</i>	<i>Qty.</i>	<i>Description</i>
1	114-8471	1	LH Main Housing Kit	35	135-1361	1	Bearing-Ball
2	114-8472	1	LH Side Cover Kit	36	130-8477	1	Bearing-Ball
3	117-5359	16	Screw-HHF	37	104-2144	1	Seal
4	114-1678	5	O-Ring	38	114-1697	1	Pawl-Brake
5	135-1140	1	Plug-Straight	39	114-1698	1	Shaft-Brake, Inboard
6	109-3321	1	Element-Oil Filter, HYD	40	125-0021	1	Handle-Brake
7	106-8676	1	Seal-Lip	41	131-0906	1	Ring-Retaining, EXT
8	106-8677	1	Ring-Retaining, External	42	104-2120	3	Screw
9	114-1685	1	Rod-Bypass	43	120-7981	1	Guard-Filter, RH
10	106-8679	1	Ring-Retaining, Internal	44	109-3278	1	Adapter-Straight
11	106-8680	1	Arm-Bypass	44:1	237-42	1	O-Ring
12	106-8681	1	Ring-Retaining, External	45	126-3251	2	Tube-Charge
13	104-5304	1	Swashplate-Trunnion	46	114-8458	1	Spacer
14	104-5313	1	Seal-Lip	47	114-8459	1	Arm-Neutral, Right
15	114-8491	1	Washer	48	106-8682	1	Screw-Sh
16	104-5308	1	Spacer	49	115-8307	1	Spring-Extension
17	104-5310	1	Seal-Lip	50	131-0908	1	Seal-Gerotor
18	104-5309	1	Ring-Retaining	51	121-5745	1	Spacer
19	112-4154	1	Bearing-Thrust	52	109-3537	1	Seal Kit
20	114-1689	1	Motor Cylinder Block Kit	53	120-7980	1	LH Center Section Charge Kit
21	94-6922	1	Bearing-Thrust	54	114-8464	1	Charge Relief Kit
22	110-8561	1	Pump Block ASM	55	114-8465	1	Charge Kit
23	104-5339	1	Washer-Flat	55:3	109-3540	1	O Ring-Seal
24	104-5340	1	Ring-Retaining	56	117-5361	1	Input Shaft Kit
25	126-0788	1	Gear-16T	57	126-2291	1	Control Arm Kit
26	114-1691	1	Shaft-Motor	58	114-8470	1	Axle Shaft Kit
27	104-5360	1	Washer	60	116-9705	1	Hub-Pulley
28	94-1933	2	Washer	61	116-9706	1	Fan
29	125-0000	1	Gear-43T	62	116-9707	1	Pulley
30	120-7974	1	Gear-11T	63	116-9708	1	Washer-Slotted
31	104-5329	1	Pin-Jackshaft	64	116-9714	1	Nut-HJ
32	104-2169	1	Ring-Retaining	99	135-3604	1	Brake Shaft Seal Kit ●
33	114-1694	1	Gear-54T				
34	120-7975	1	Spacer				

● Not illustrated

# Axle and Bearing Assembly No. 116-9545

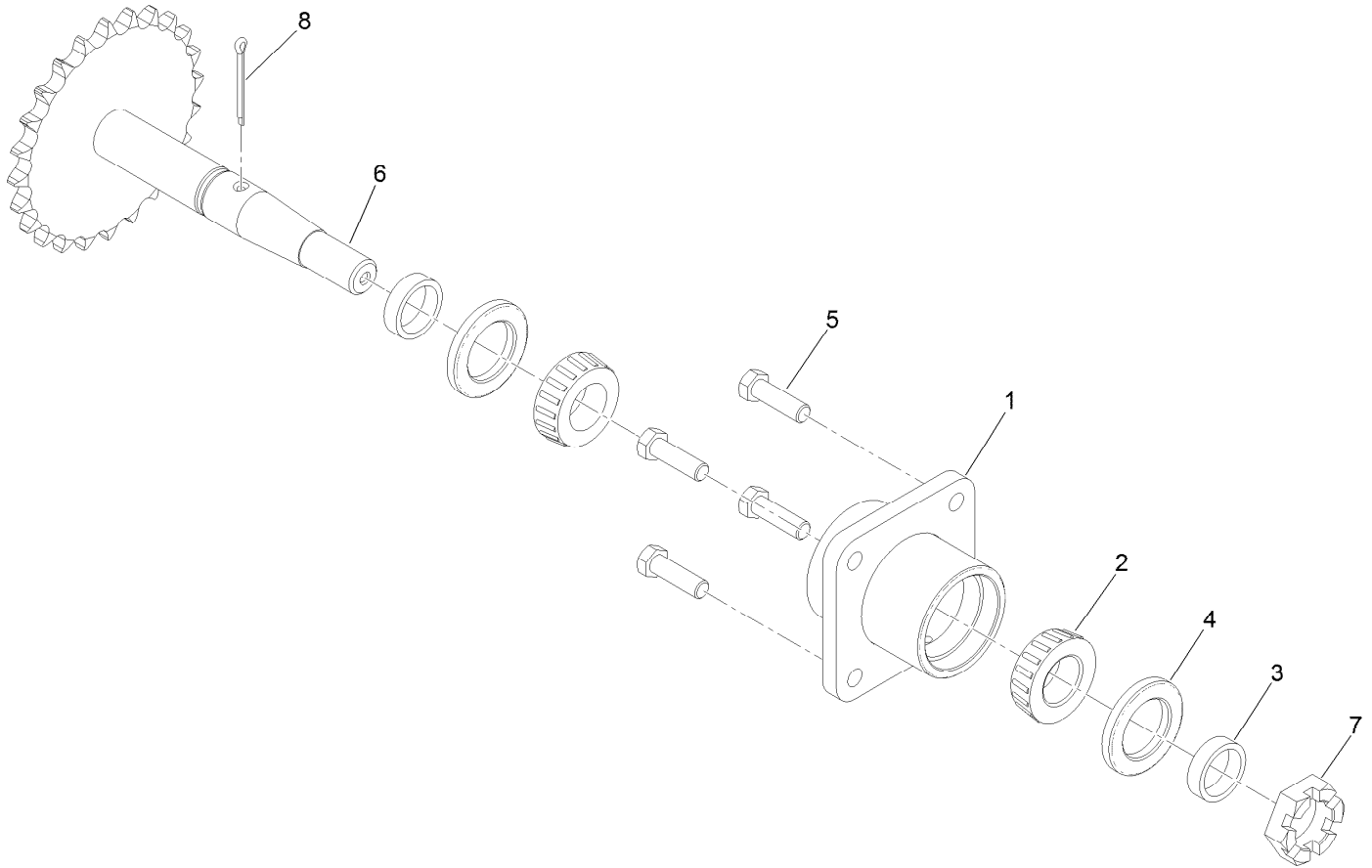

## Axle and Bearing Assembly No. 116-9545 (continued)

<i>Ref.</i>	<i>Part Number</i>	<i>Qty.</i>	<i>Description</i>	<i>Ref.</i>	<i>Part Number</i>	<i>Qty.</i>	<i>Description</i>
1	116-6746-01	1	Mount-Bearing, Wheel	5	323-7	4	Screw-HH
2	1-543509	2	Bearing-Roller, Tapered	6	126-0459	1	Axle
3	116-6758	2	Spacer	7	99-3139	1	Nut-Slotted
4	1-543511	2	Seal-Grease	8	1-806800	1	Pin-Cotter

# Tine Assembly

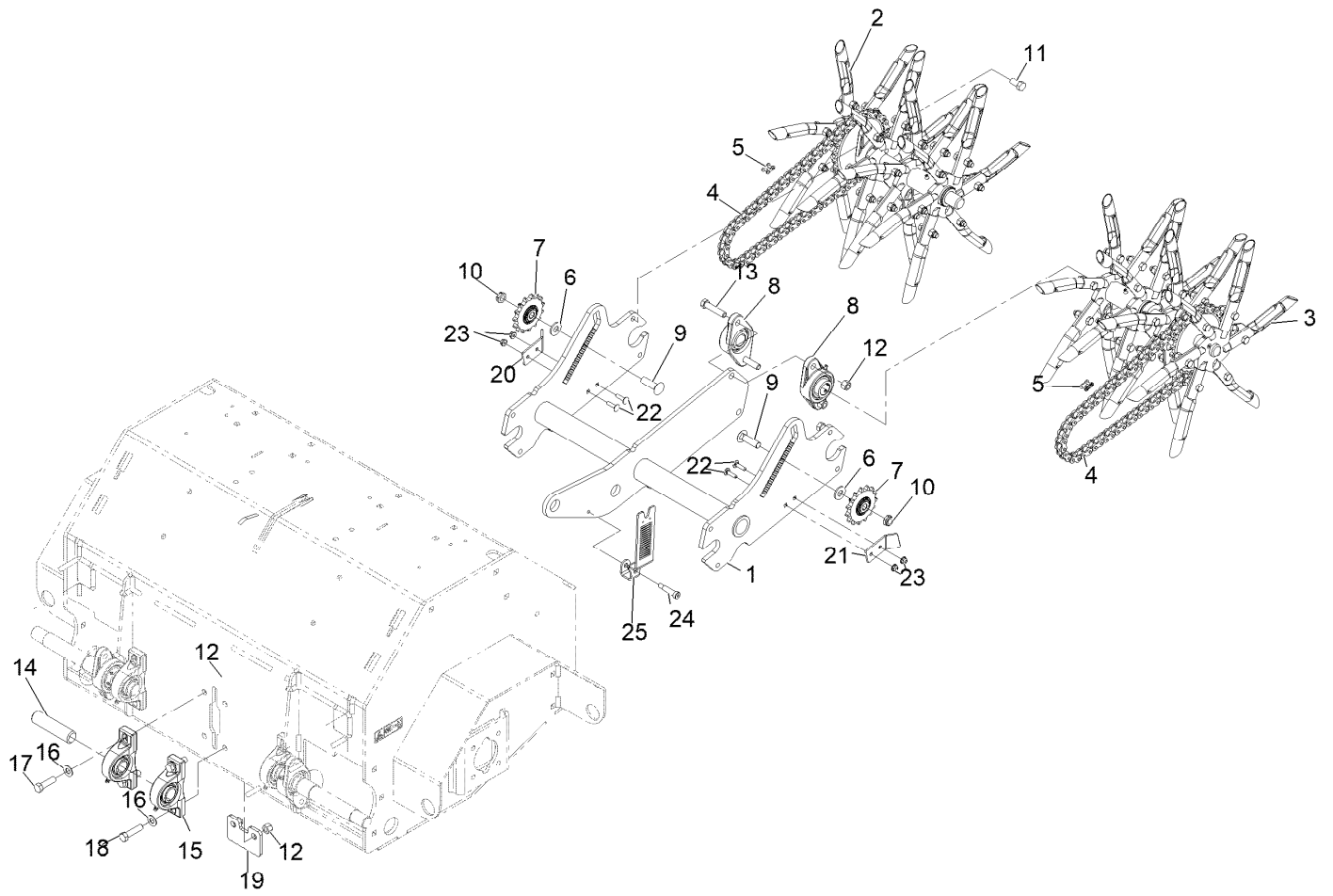



## Tine Assembly (continued)

<i>Ref.</i>	<i>Part Number</i>	<i>Qty.</i>	<i>Description</i>	<i>Ref.</i>	<i>Part Number</i>	<i>Qty.</i>	<i>Description</i>
1	135-5952-03	1	Arm-Trail	14	116-6629	1	Shaft
2	135-2507	1	RH Tine Wheel ASM	15	116-6756	2	Bearing-Pillow Block ●
3	135-2510	1	LH Tine Wheel ASM	16	3256-25	4	Washer-7/16 SAE
4	126-8808	2	Chain-Roller	17	324-6	2	Screw-HH 7/16-14 X 1 1/2
5	116-6897	2	Link-Connecting	18	324-7	2	Screw-HH
6	87-7270	2	Washer-Thrust	19	116-7327-01	1	Plate-Downstop
7	126-9108	2	Sprocket-Idler, 15T	20	126-4192-03	1	Guard-Chain, RH
8	116-6777	2	Bearing-Flange, 2 Bolt	21	126-4193-03	1	Guard-Chain, LH
9	3233-14	2	Screw-CARR	22	3229-30	4	Bolt-Carriage 1/4-20 X 1
10	3296-45	2	Nut-Nyloc 1/2-13 Thin	23	104-7201	4	Nut-Nyloc 1/4-20 Flg
11	135-7810	4	Screw-HH ●	24	114-0239	1	Screw-Shoulder 5/16-18 X 1/2
12	3296-48	6	Nut-Nyloc 7/16-14				
13	324-8	2	Screw-HH	25	135-5109	1	Bracket-Control, Depth

● Use Pro-Lock, Nut Type (P/N 1-840022, .5ml tube) on threads.

# RH Tine Wheel Assembly No. 135-2507

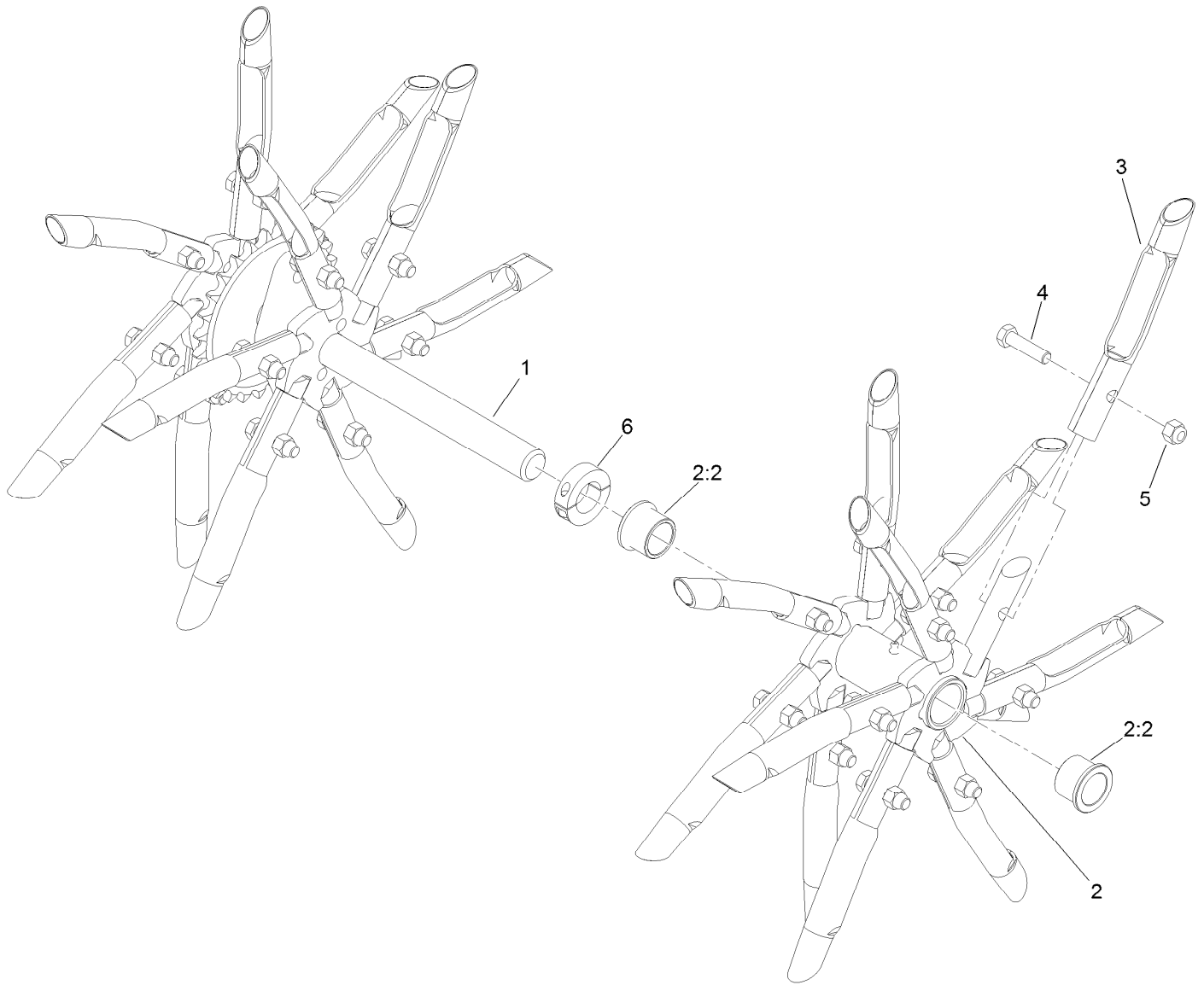

## RH Tine Wheel Assembly No. 135-2507 (continued)

<i>Ref.</i>	<i>Part Number</i>	<i>Qty.</i>	<i>Description</i>	<i>Ref.</i>	<i>Part Number</i>	<i>Qty.</i>	<i>Description</i>
1	135-4341	1	Shaft-Tine, RH	4	323-8	24	Screw-HH
2	135-4342	1	Tine Shaft Float ASM	5	3296-39	24	Nut-Lock, NI
2:2	94-8949	2	Bushing-Flange	6	116-7271	1	Collar-Locking
3	126-2143	24	Tine-Coring (3/4 Inch)				

# LH Tine Wheel Assembly No. 135-2510

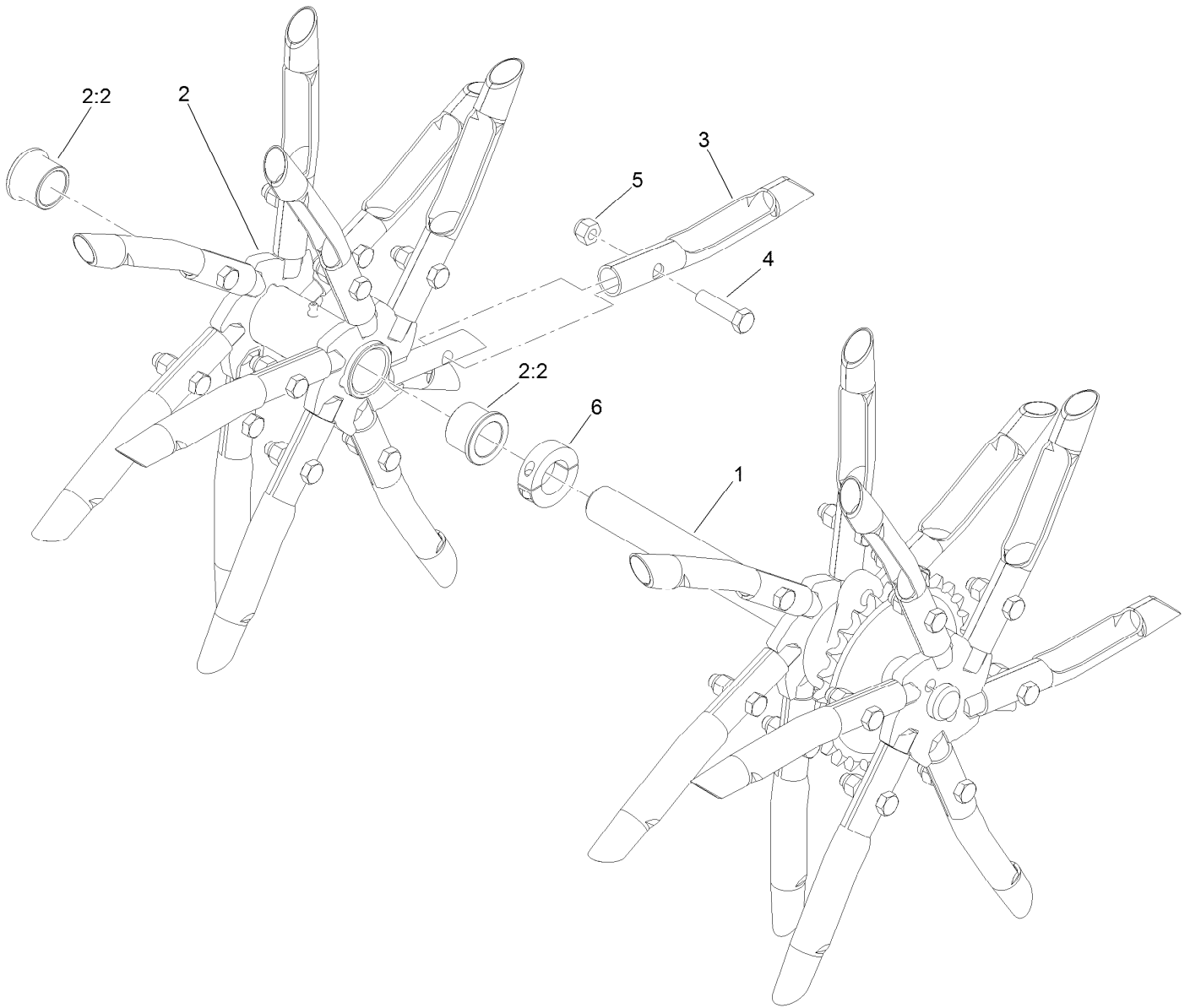

# LH Tine Wheel Assembly No. 135-2510 (continued)

<i>Ref.</i>	<i>Part Number</i>	<i>Qty.</i>	<i>Description</i>
1	135-4343	1	Shaft-Tine, LH
2	135-4342	1	Tine Shaft Float ASM
2:2	94-8949	2	Bushing-Flange
3	126-2143	24	Tine-Coring (3/4 Inch)

<i>Ref.</i>	<i>Part Number</i>	<i>Qty.</i>	<i>Description</i>
4	323-8	24	Screw-HH
5	3296-39	24	Nut-Lock, NI
6	116-7271	1	Collar-Locking ●

● Use Loctite® 243 on threads.

# Fuel Assembly

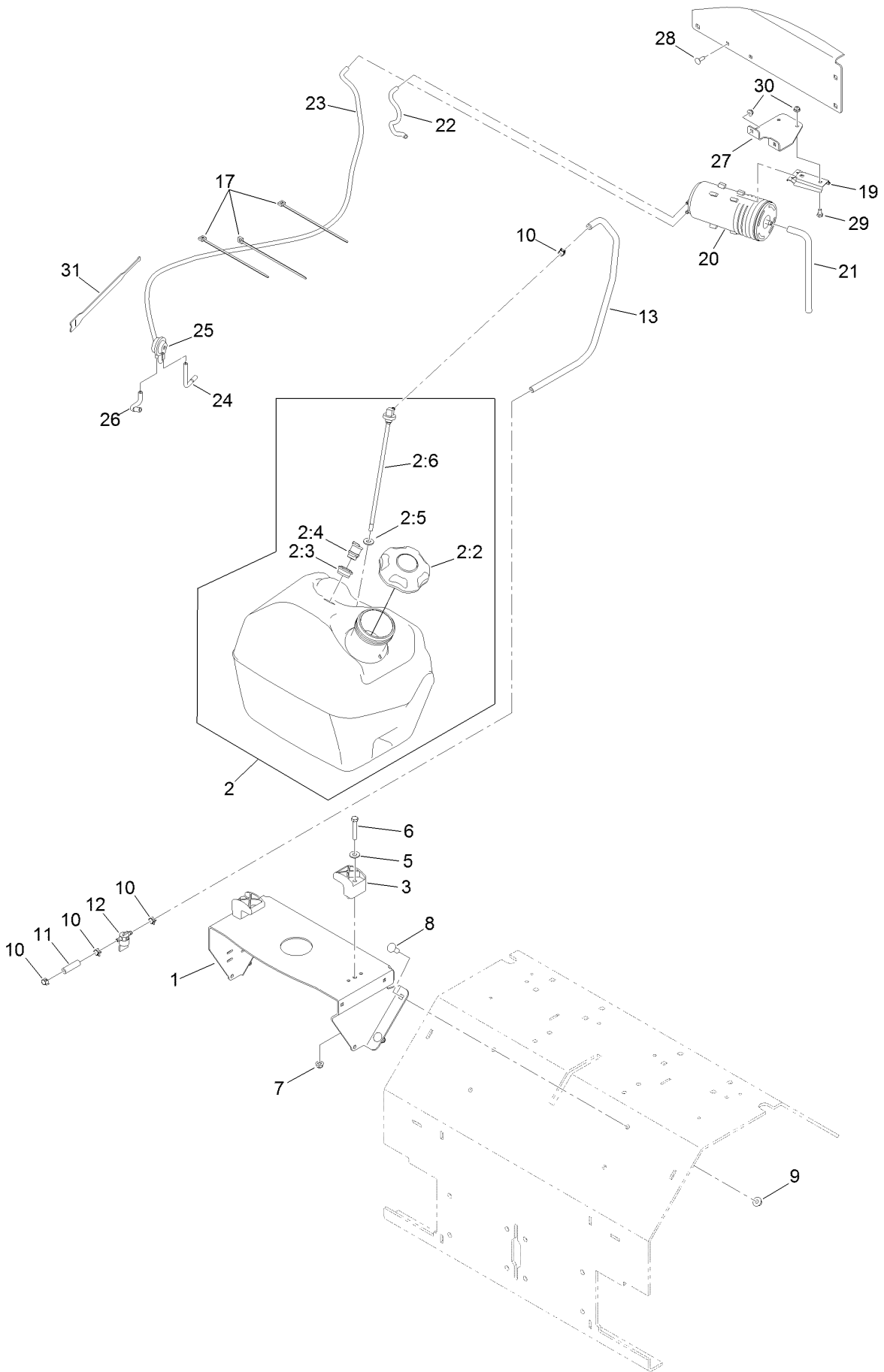

## Fuel Assembly (continued)

<i>Ref.</i>	<i>Part Number</i>	<i>Qty.</i>	<i>Description</i>	<i>Ref.</i>	<i>Part Number</i>	<i>Qty.</i>	<i>Description</i>
1	116-9541-01	1	Support-Tank, Fuel	12	1-603770	1	Valve-Fuel
2	137-9502	1	Fuel Tank ASM	13	135-0494	1	Hose-Fuel
2:2	137-4119	1	Cap-Fuel, Ratcheting	17	3290-378	3	Tie-Cable
2:3	114-0284	1	Grommet	19	114-0292	1	Bracket-Canister, Carbon
2:4	119-3547	1	Valve-Vent, Fuel	20	117-1221	1	Canister-Carbon, 800Cc
2:5	46-6560	1	Bushing	21	115-0962	1	Hose-Vent, Canister
2:6	109-9364	1	Fitting-Fuel (W/Line And Screen)	22	135-0986	1	Hose-Emissions
3	107-4543	2	Clamp	23	126-4179	1	Hose-Vent, Formed
5	3256-3	2	Washer-Flat	24	119-8501	1	Hose-Vent, Formed
6	322-10	2	Screw-HH	25	116-2232	1	Valve-Control, Vacuum
7	104-8300	2	Nut-HF, NI	26	119-8502	1	Hose-Vent, Formed
8	3231-22	4	Screw-CARR	27	126-2991-03	1	Bracket-Mounting, Canister
9	104-8301	4	Nut-HF, NI	28	3229-1	2	Screw-CARR
10	2412-98	4	Clamp-Hose	29	321-2	2	Screw-HH
11	119-7856	1	Hose-Fuel	30	104-7201	4	Nut-Flange, NI
				31	116-2469	1	Strap-Velcro, Cable Tie

# Motion Control Assembly

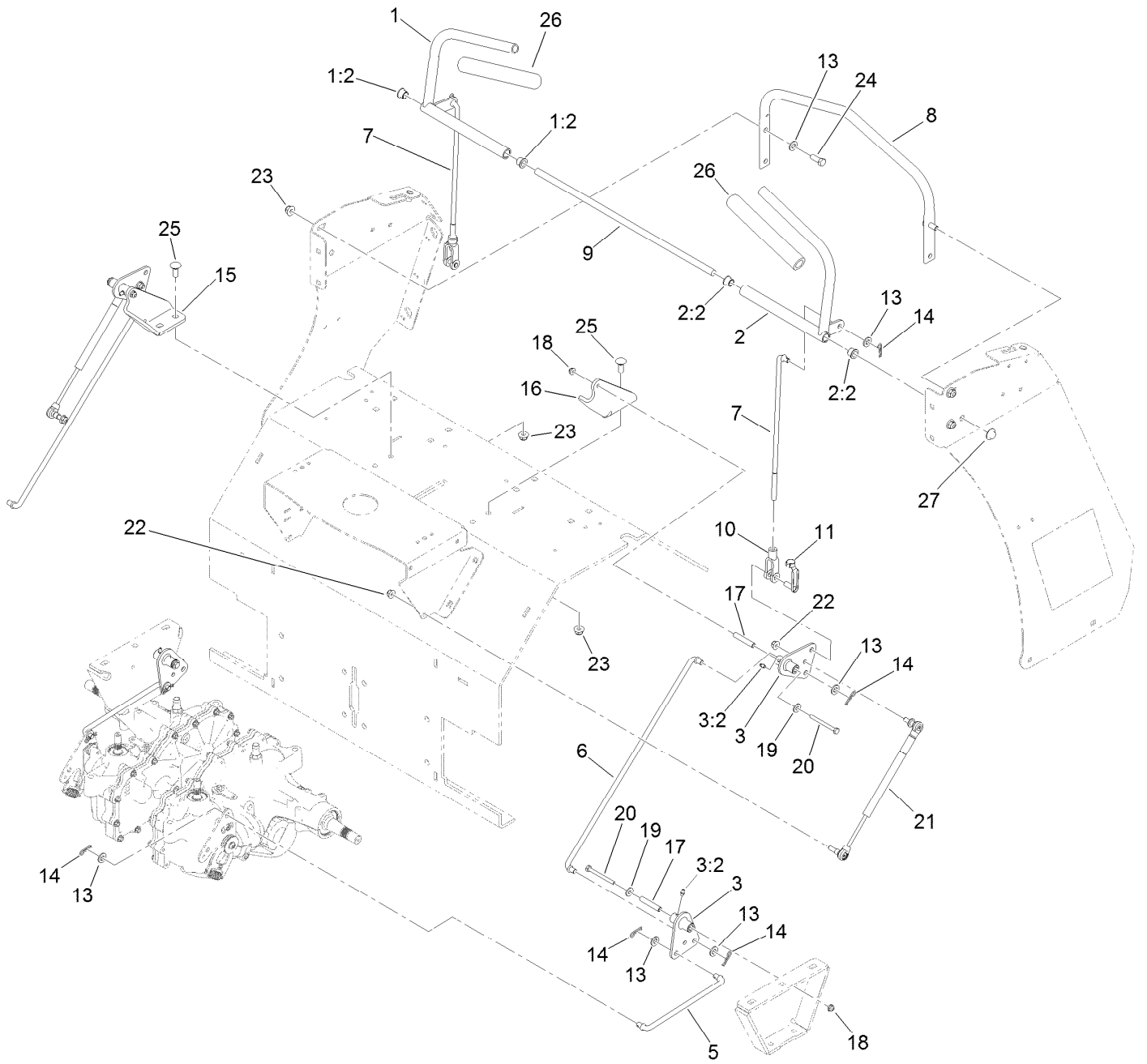



## Motion Control Assembly (continued)

<i>Ref.</i>	<i>Part Number</i>	<i>Qty.</i>	<i>Description</i>	<i>Ref.</i>	<i>Part Number</i>	<i>Qty.</i>	<i>Description</i>
1	116-6567	1	RH Control Handle ASM	14	1-806003	10	Pin-Cotter
1:2	116-4279	2	Bearing-Flange	15	116-6576-03	1	Bracket-Pivot, RH
2	116-6566	1	LH Control Handle ASM	16	116-6577-03	1	Bracket-Pivot, LH
2:2	116-4279	2	Bearing-Flange	17	116-7224	4	Spacer
3	126-0340	4	Crank-Bell	18	104-7201	4	Nut-Flange, NI
3:2	302-19	1	Fitting-Grease	19	3256-2	4	Washer-Flat
5	116-6722	2	Link-Control, Hydro	20	321-14	4	Screw-HH
6	116-9298	2	Link-Control, Bell Crank	21	116-0027	2	Damper-Control, Motion
7	116-6730	2	Link-Control, Bell Crank	22	104-8300	4	Nut-HF, NI
8	116-6608-03	1	Bar-Reference	23	104-8301	8	Nut-HF, NI
9	116-6607	1	Shaft-Pivot, Control	24	323-6	4	Screw-HH
10	1-633131	2	Yoke-Linkage, Brake	25	3231-2	4	Bolt-CARR
11	103-2399	2	Pin-Spring, Clevis	26	103-8153	2	Grip-Lever, Control
13	3256-24	14	Washer-Flat	27	32112-14	2	Nut-Push

# Electrical Assembly

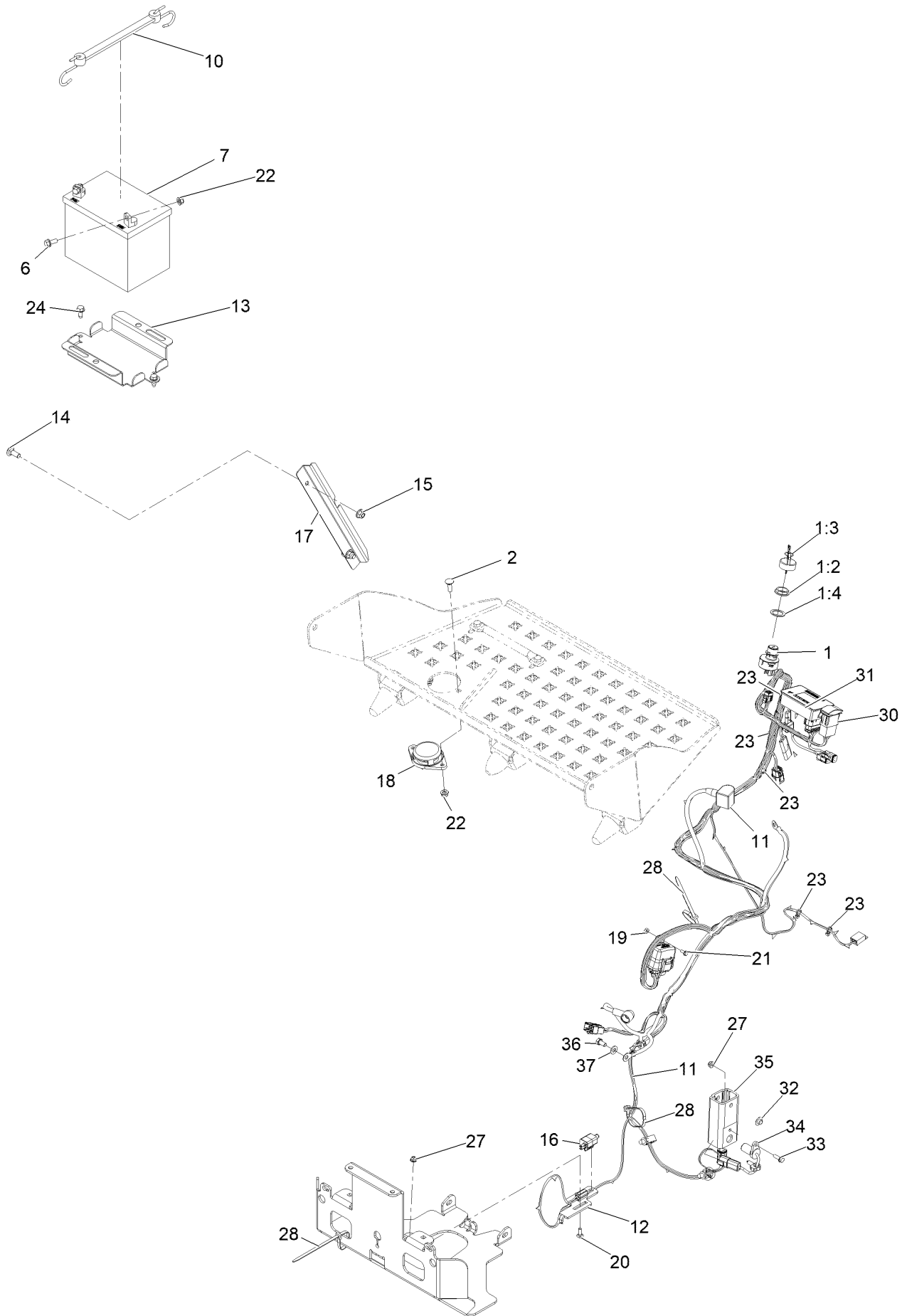

## Electrical Assembly (continued)

<i>Ref.</i>	<i>Part Number</i>	<i>Qty.</i>	<i>Description</i>	<i>Ref.</i>	<i>Part Number</i>	<i>Qty.</i>	<i>Description</i>
1	126-6285	1	Ignition Switch ASM	20	3229-1	1	Bolt-Carriage 1/4-20 X 3/4
1:2	108-8660	1	Nut-Mounting	21	3290-321	2	Screw-HWH
1:3	106-5270	1	Ignition Key Set	22	104-8300	4	Nut-Nyloc 5/16-18 Flg
1:4	108-8659	1	Washer-Backup	23	1-303287	5	Tie-Cable 5 1/2 (Small)
2	3230-2	2	Bolt-Carriage 5/16-18 X 1	24	32144-70	2	Screw-HWH 5/16-18 X 3/4 Tf
6	3234-5	2	Screw-HH Flg 5/16-18 X 3/4	27	104-7201	2	Nut-Nyloc 1/4-20 Flg
7	99-7421	1	Battery	28	3290-378	5	Tie-Cable
10	104-2466	1	Holddown-Battery	30	100-1535	1	Switch-Rocker, (On)-Off-(On)
11	135-5919	1	Harness-Wire ●	31	135-6910	1	Hour Meter ASM
12	116-7589	1	Mount-Switch	32	3290-320	1	Nut-Push
13	116-9383-03	1	Bracket-Battery	33	32105-15	1	Screw-Machine 1/4-20 X 3/4
14	3231-2	2	Bolt-Carriage 3/8-16 X 1	34	135-4381	1	Sensor, Quadrature
15	104-8301	2	Nut-Nyloc 3/8-16 Flg	35	135-6609	1	Housing-Depth Control 30
16	110-6765	1	Switch	36	33114-016	1	Screw-HH M8-1.25 X 16Mm
17	116-9394-03	1	Guard-Harness	37	33094-00	1	Washer
18	92-6282	1	Switch-Seat				
19	3296-2	2	Nut-Nyloc #10-24				

● Use dielectric grease on all unsealed connectors and terminals only. Do not apply in sealed connectors.

# Auxiliary Hydraulic Assembly

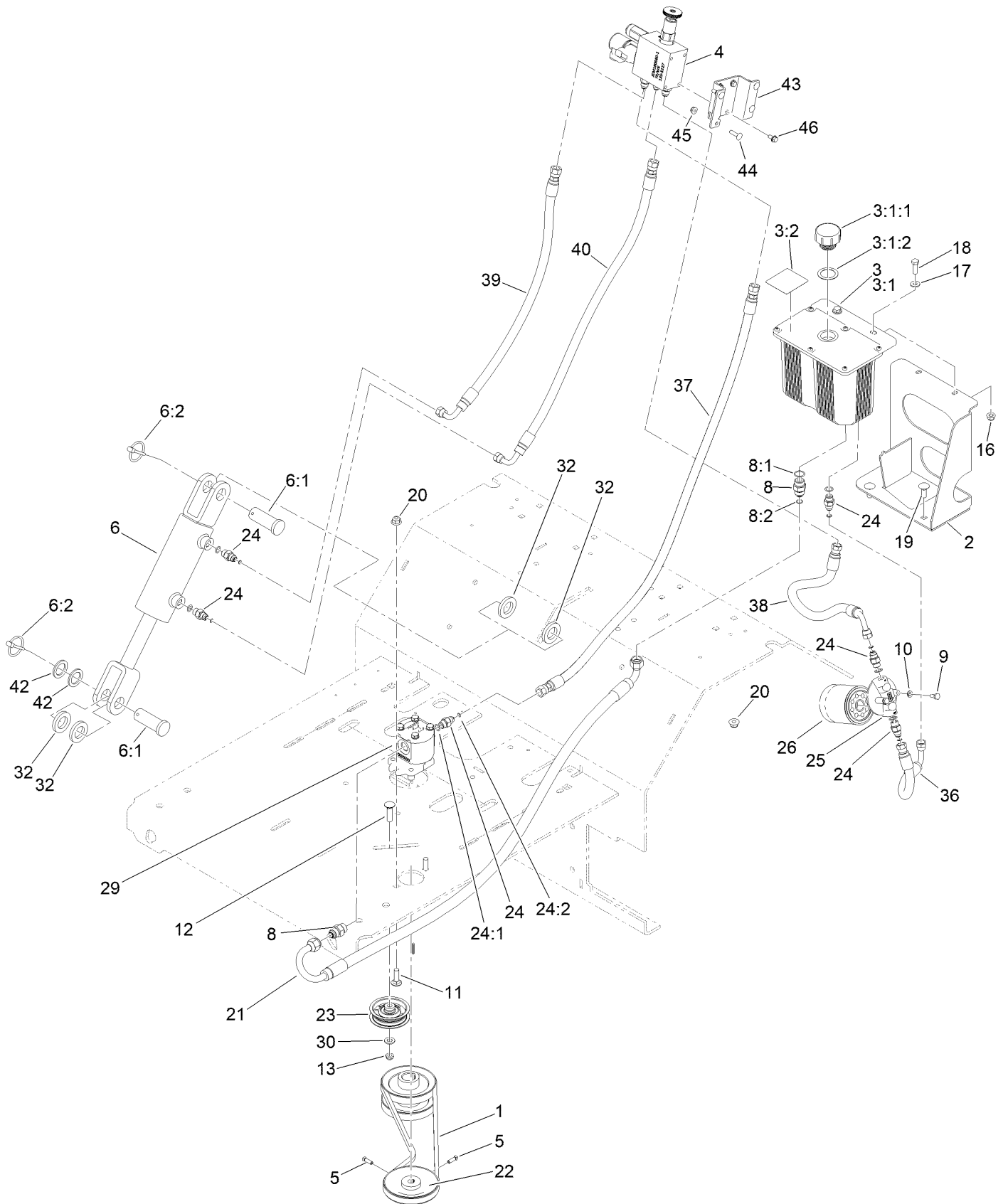

## Auxiliary Hydraulic Assembly (continued)

<i>Ref.</i>	<i>Part Number</i>	<i>Qty.</i>	<i>Description</i>	<i>Ref.</i>	<i>Part Number</i>	<i>Qty.</i>	<i>Description</i>
1	116-8874	1	Belt-4L Section	19	3231-2	4	Bolt-CARR
2	116-6618-03	1	Bracket-Tank, Hydraulic	20	104-8301	6	Nut-HF, NI
3	116-7557	1	Reservoir ASM	21	116-9309	1	Hose-Hydraulic
3:1		1	Tank-Hydraulic ■	22	116-6667	1	Pulley
3:1:1	103-1948	1	Cap-Reservoir, HYD	23	116-6760	1	Pulley-Idler, Flat
3:1:2	103-1949	1	Gasket-Cap	24	103-2156	6	Fitting-Straight
3:2	115-4212	1	Decal-Warning	24:1	1-603921	1	O-Ring
4	135-5127	1	Manifold ASM	24:2	103-1020	1	O-Ring
5	3241-6	2	Screw-SQH ▲	25	104-7836	1	Head-Filter
6	116-6969	1	HYD Cylinder ASM	26	1-633750	1	Filter-Oil, HYD
6:1	116-7290	2	Pin-Clevis	29	116-9129	1	Hydraulic Pump ASM
6:2	92-1298	2	Pin-Lynch	30	3256-24	1	Washer-Flat
6:3	127-3234	1	Seal Kit ●	32	116-6781	5	Spacer
8	1-603990	2	Fitting-Straight	36	116-6675	1	Hose-Hydraulic, LP
8:1	1-603920	1	O-Ring	37	116-8151	1	Hose-Hydraulic
8:2	1-603992	1	O-Ring	38	116-9308	1	Hose-Hydraulic
9	321-3	2	Screw-HH	39	116-6677	1	Hose-Hydraulic
10	1-805004	2	Washer-Lock	40	135-5973	1	Hydraulic Hose ASM
11	3231-25	2	Bolt-CARR	42	3-8514	2	Washer-Thrust
12	3231-4	1	Screw-CARR	43	135-3603-03	1	Bracket-Sensor, Control (Depth)
13	3296-59	1	Nut-Lock, NI	44	3229-30	4	Screw-CARR
16	104-8300	2	Nut-HF, NI	45	104-7201	4	Nut-Flange, NI
17	3256-2	2	Washer-Flat	46	119-1065	4	Screw-HWH
18	322-5	2	Screw-HH				

● Not illustrated

▲ Use Pro-Lock, Nut Type (P/N 1-840022, .5ml tube) on threads.

■ Not serviced separately

# Hydraulic Pump Assembly No. 116-9129

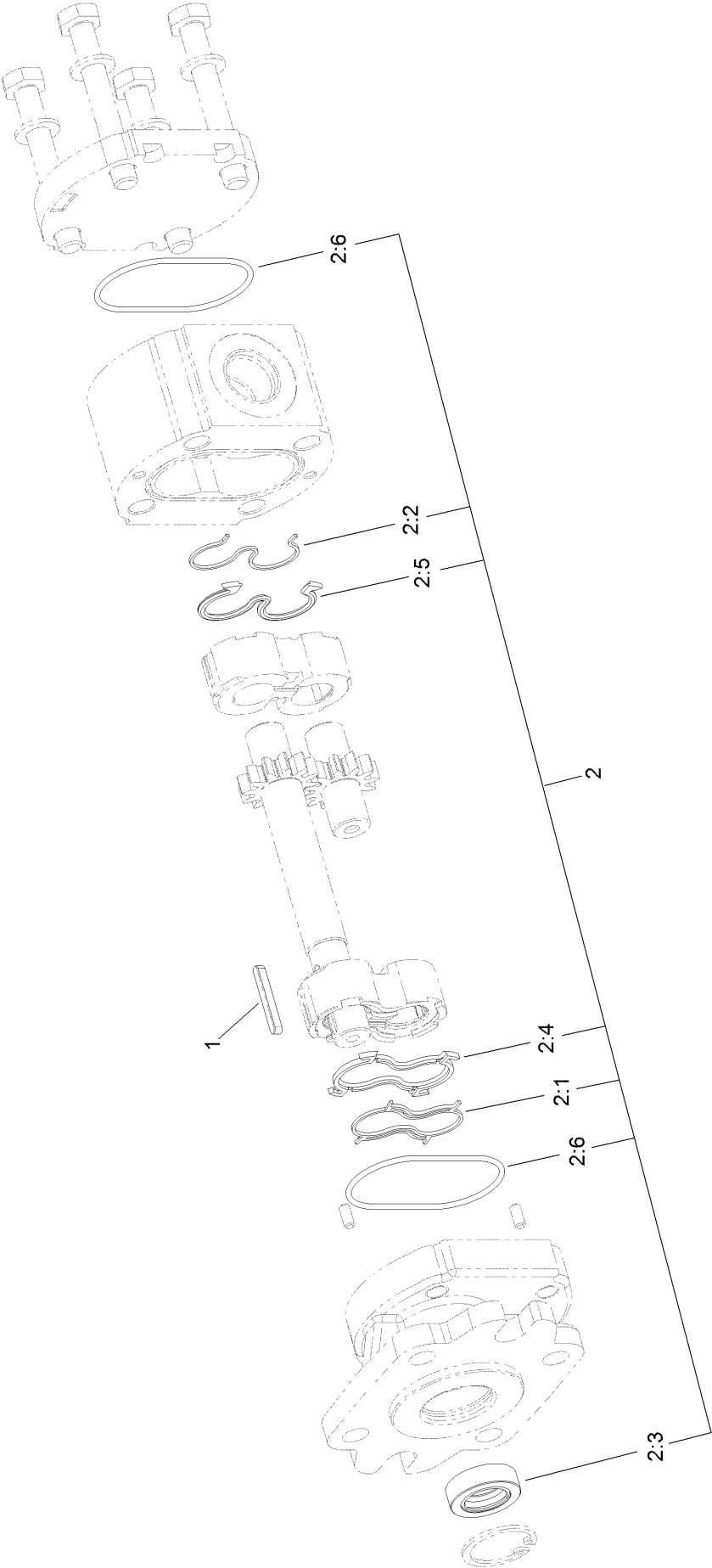

# Hydraulic Pump Assembly No. 116-9129 (continued)

<i>Ref.</i>	<i>Part Number</i>	<i>Qty.</i>	<i>Description</i>	<i>Ref.</i>	<i>Part Number</i>	<i>Qty.</i>	<i>Description</i>
1	115-7855	1	Key-Square	2:3		1	Seal-Shaft ●
2	112-0199	1	Seal Kit	2:4		1	Seal-Upper ●
2:1		1	Seal-Anti Extrusion ●	2:5		1	Seal ●
2:2		1	Seal-Anti Extrusion ●	2:6		2	O-Ring ●

● Not serviced separately

# Engine Assembly

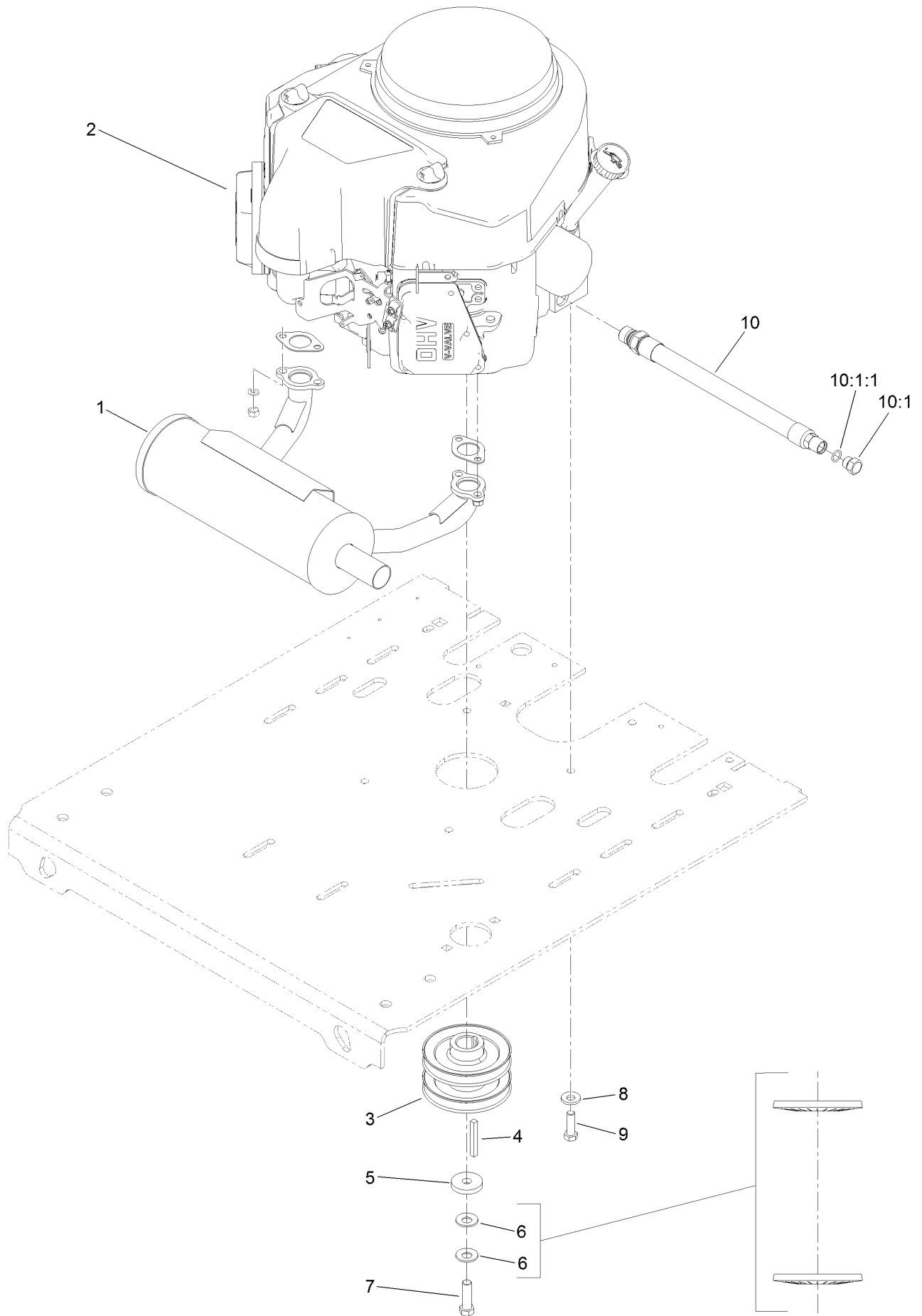



## Engine Assembly (continued)

<i>Ref.</i>	<i>Part Number</i>	<i>Qty.</i>	<i>Description</i>	<i>Ref.</i>	<i>Part Number</i>	<i>Qty.</i>	<i>Description</i>
1	116-3735	1	Muffler-Horizontal	8	98-5975	4	Washer-Belleville
2		1	Engine-Kawasaki, Fs541 ■▲	9	323-7	4	Screw-HH
3	116-9709	1	Pulley	10	116-4924	1	Engine Oil Drain Hose ASM
4	103-4177	1	Key				◆
5	1-543610	1	Washer-Clutch	10:1	353-508	1	Plug-HH ●
6	1-603610	2	Washer-Spring	10:1:1	237-42	1	O-Ring
7	109-9761	1	Screw-HH □				

● Torque to 24-26 ft-lb

▲ Obtain parts from [www.kawpower.com](http://www.kawpower.com)

◆ Use a Teflon Pipe Sealant or equivalent on threads.

□ Use Pro-Lock, Nut Type (P/N 1-840022, .5ml tube) on threads.

■ Not serviced separately

**Notes:**

**Notes:**



**Count on it.**