



EN Steel Tub, Material Buggies

68101

ES Cuba de acero, Carretillas

68101

FR Bac en acier, Buggies de transport de matériaux

68101

NL Stalen kuip, Materiaalbuggy's

68101





Steel Tub Material Buggies

Model No. 68101—Serial No. 321000001 and Up

Installation Instructions

Safety

Safety and Instructional Decals



Safety decals and instructions are easily visible to the operator and are located near any area of potential danger. Replace any decal that is damaged or missing.

WARNING: Cancer and Reproductive Harm - www.P65Warnings.ca.gov.
For more information, please visit www.ttcoCAProp65.com

133-8061
decal133-8061

133-8061

1. Park the machine on a level surface, engage the parking brake, lower the hopper, shut off the engine, and remove the key.
2. Remove the existing tub; retain the hardware.
3. Secure the new tub to the frame using the previously removed 4 bolts, 4 washers, and 4 nuts.

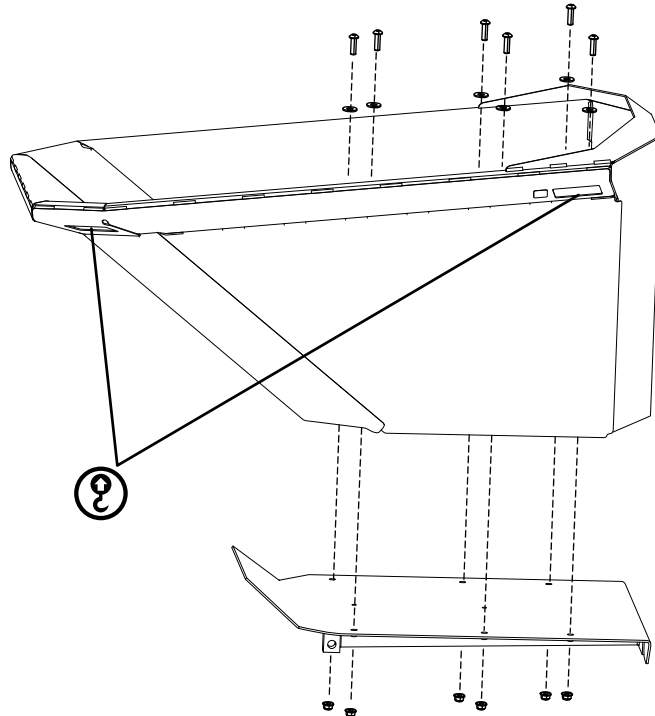

Figure 1

g347428



⚠ WARNING

Using a drill without proper eye protection may allow debris to enter the eye, causing injury.

When drilling, always wear eye protection.

- Using the new tub as a template, mark and drill 2 holes (9/16 inch).

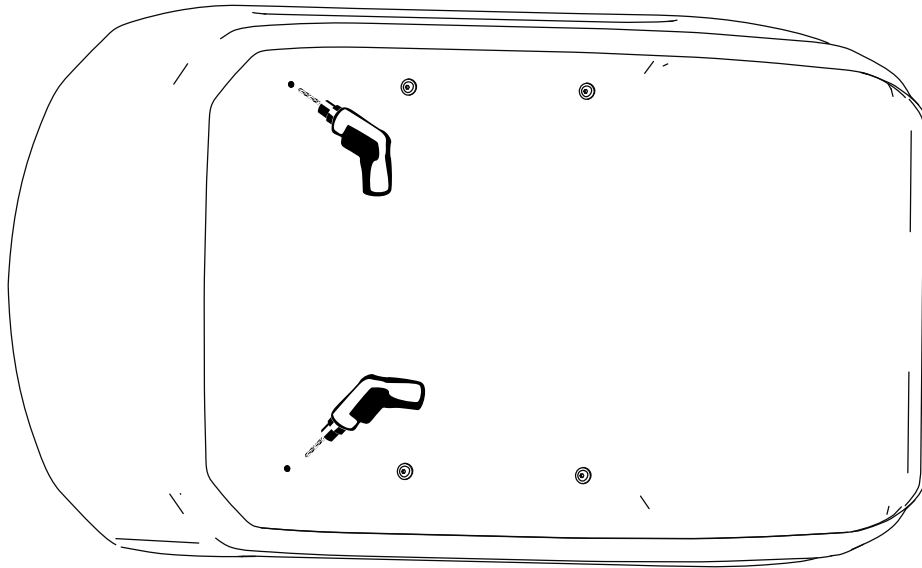

Figure 2

g322994

- Install the remaining hardware to secure the tub to the frame.

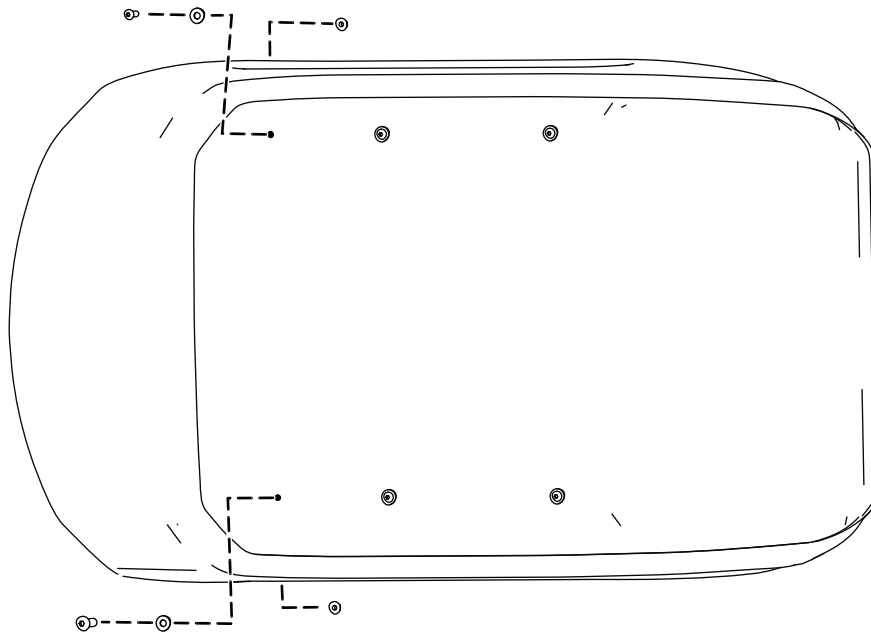

Figure 3

g322996

- Torque the bolt to 37 to 45 N·m (27 to 33 ft·lb).



Cuba de acero

Carretillas

Nº de modelo 68101—Nº de serie 321000001 y superiores

Instrucciones de instalación

Seguridad

Pegatinas de seguridad e instrucciones



Las pegatinas de seguridad e instrucciones están a la vista del operador y están ubicadas cerca de cualquier zona de peligro potencial. Sustituya cualquier pegatina que esté dañada o que falte.

WARNING: Cancer and Reproductive Harm - www.P65Warnings.ca.gov.
For more information, please visit www.ttcoCAProp65.com

133-8061
decal133-8061

133-8061

1. Aparque la máquina en una superficie nivelada, ponga el freno de estacionamiento, baje la tolva, apague el motor y retire la llave.
2. Retire la cuba existente. Guarde los herrajes.
3. Sujete la cuba nueva al bastidor con 4 pernos, 4 arandelas y 4 tuercas que retiró anteriormente.



Figura 1

g347428

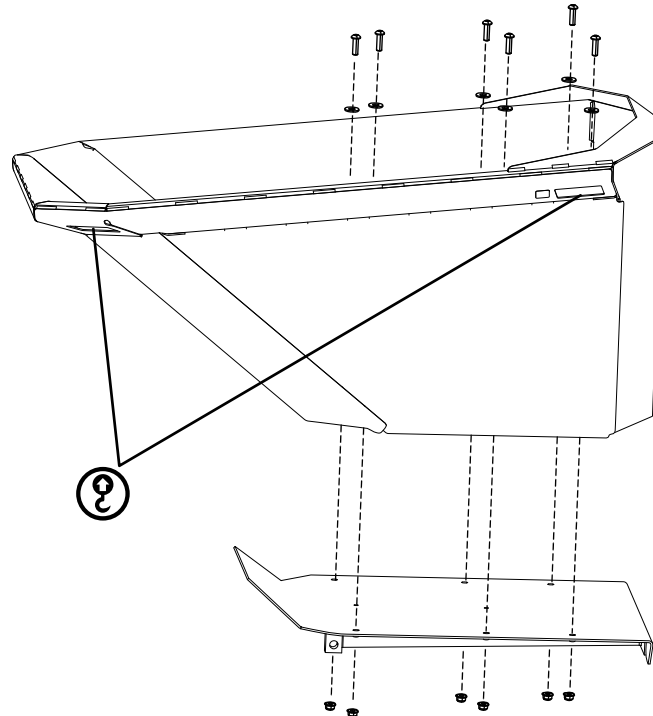

⚠ ADVERTENCIA

El uso de una taladradora sin la protección ocular adecuada puede hacer que entren residuos en los ojos y provocar lesiones.

Utilice siempre protección ocular mientras taladra.

4. Usando la cuba nueva como plantilla, marque y perforo 2 orificios (9/16").



Figura 2

g322994

5. Instale las fijaciones restantes para sujetar la cuba al bastidor.

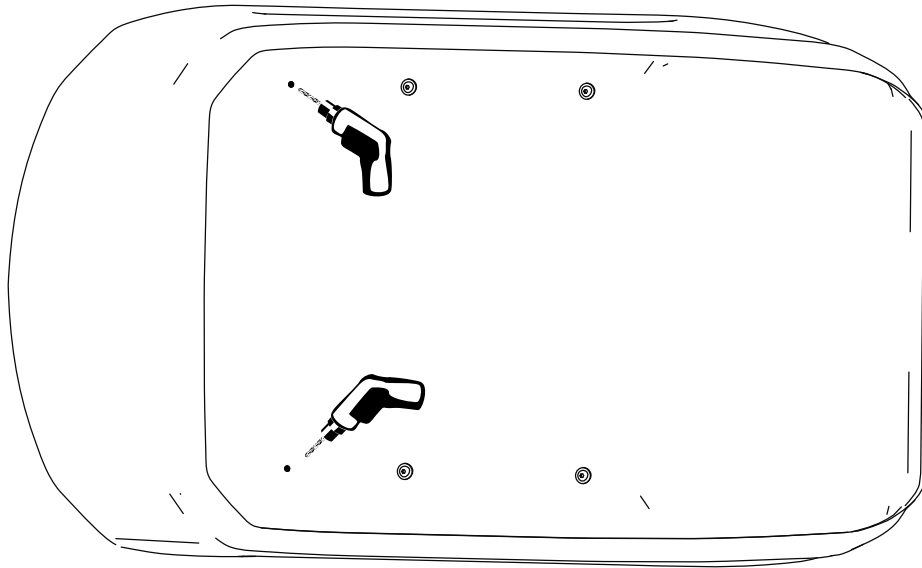

Figura 3

g322996

6. Apriete el perno a 37–45 N·m.

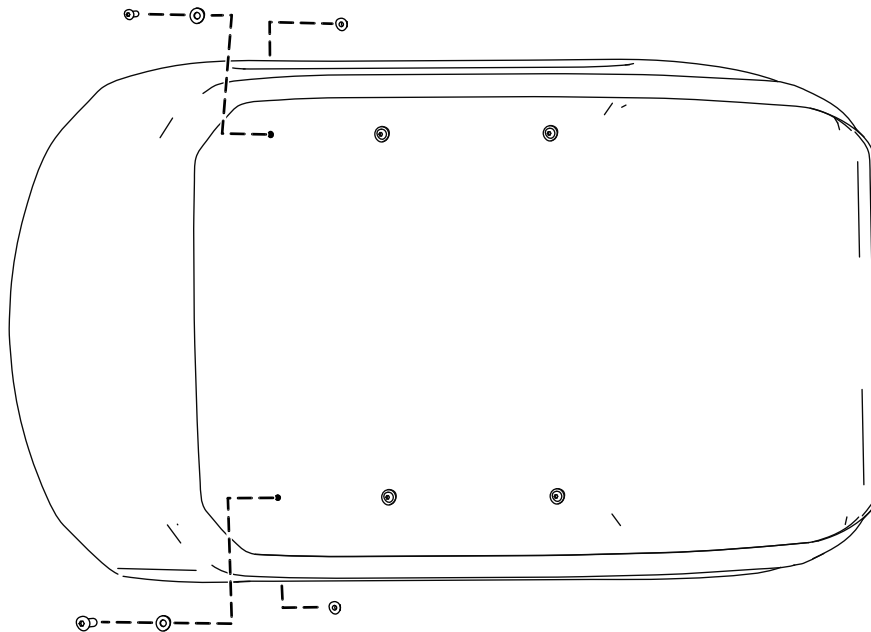

Bac en acier

Buggies de transport de matériaux

N° de modèle 68101—N° de série 321000001 et suivants

Instructions de montage

Sécurité

Autocollants de sécurité et d'instruction



Des autocollants de sécurité et des instructions bien visibles par l'opérateur sont placés près de tous les endroits potentiellement dangereux. Remplacez tout autocollant endommagé ou manquant.

▲ WARNING: Cancer and Reproductive Harm - www.P65Warnings.ca.gov.
For more information, please visit www.ttcocaprop65.com

133-8061

decal133-8061

133-8061

1. Garez la machine sur une surface plane et horizontale, serrez le frein de stationnement, abaissez la trémie, coupez le moteur et enlevez la clé.
2. Déposez le bac existant. Conservez les fixations.
3. Fixez le bac de rechange sur le cadre au moyen de 4 boulons, 4 rondelles et 4 écrous que vous avez retirés précédemment.

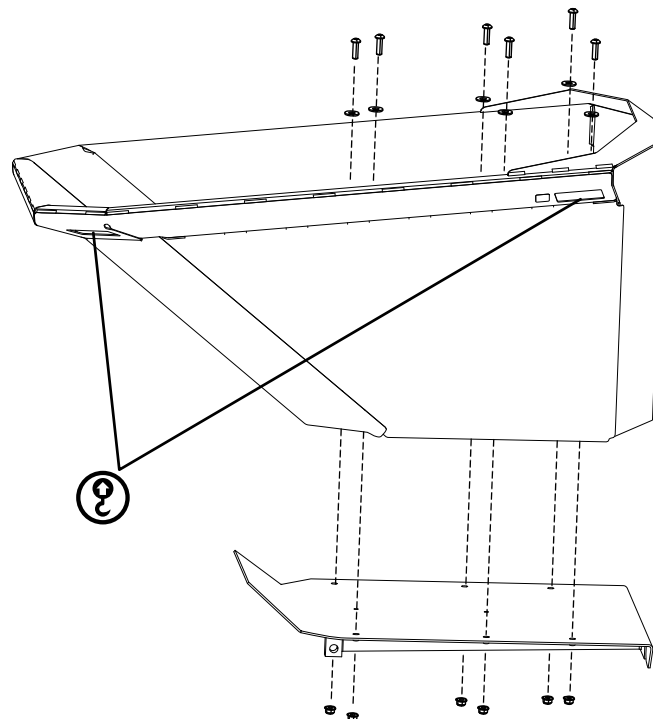

Figure 1

g347428



⚠ ATTENTION

Si vous utilisez une perceuse sans protection oculaire adéquate, des débris risquent d'atteindre vos yeux et de vous blesser.

Portez toujours une protection oculaire pour percer.

4. En vous servant du nouveau bac comme gabarit, repérez et percez 2 trous (9/16").

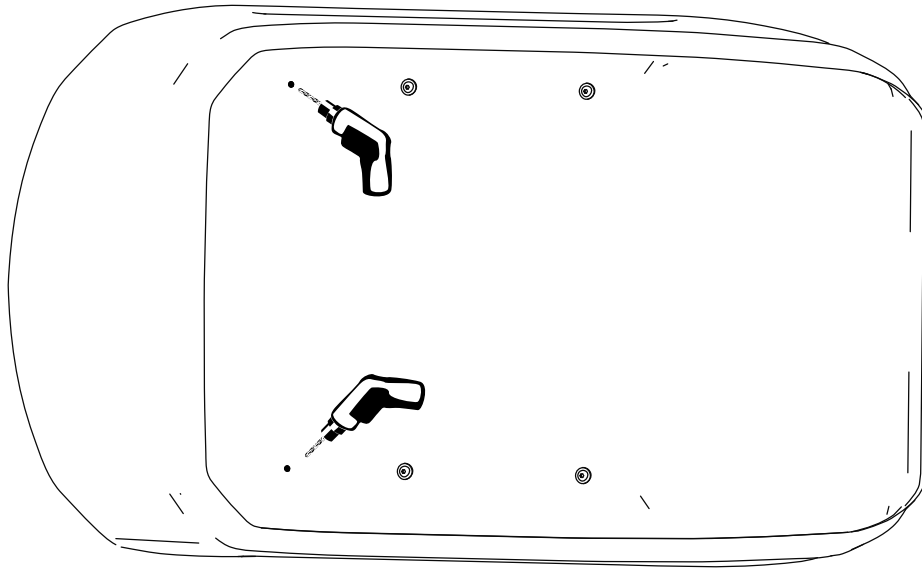

Figure 2

g322994

5. Installez les fixations restantes pour fixer le bac sur le cadre.

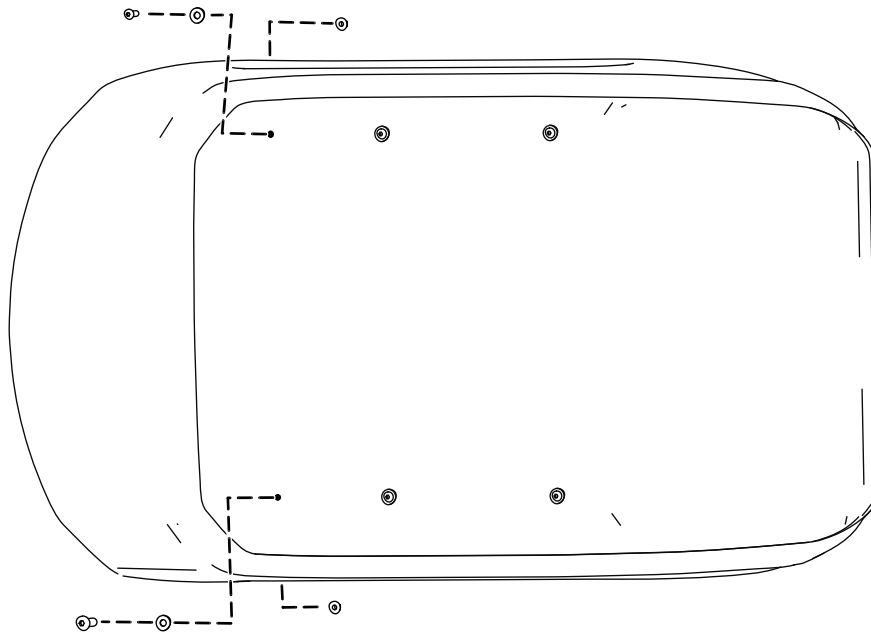

Figure 3

g322996

6. Serrez le boulon à un couple de 37 à 45 N·m.



Stalen kuip Materiaalbuggy's

Modelnr.: 68101—Serienr.: 321000001 en hoger

Form No. 3444-223 Rev D

Installatie-instructies

Veiligheid

Veiligheids- en instructiestickers



Veiligheidsstickers en veiligheidsinstructies zijn gemakkelijk zichtbaar voor de bestuurder en bevinden zich bij plaatsen waar gevaar kan ontstaan. Vervang alle beschadigde of ontbrekende stickers.

WARNING: Cancer and Reproductive Harm - www.P65Warnings.ca.gov.
For more information, please visit www.ttcoCAProp65.com

133-8061

decal133-8061

133-8061

1. Parkeer de machine op een horizontaal oppervlak, stel de parkeerrem in werking, laat de hopper zakken, schakel de motor uit en verwijder het sleuteltje.
2. Verwijder de bestaande kuip. Bewaar het bevestigingsmateriaal.
3. Bevestig de nieuwe kuip aan het frame met 4 bouten, 4 ringen en 4 moeren die u eerder verwijderd hebt.

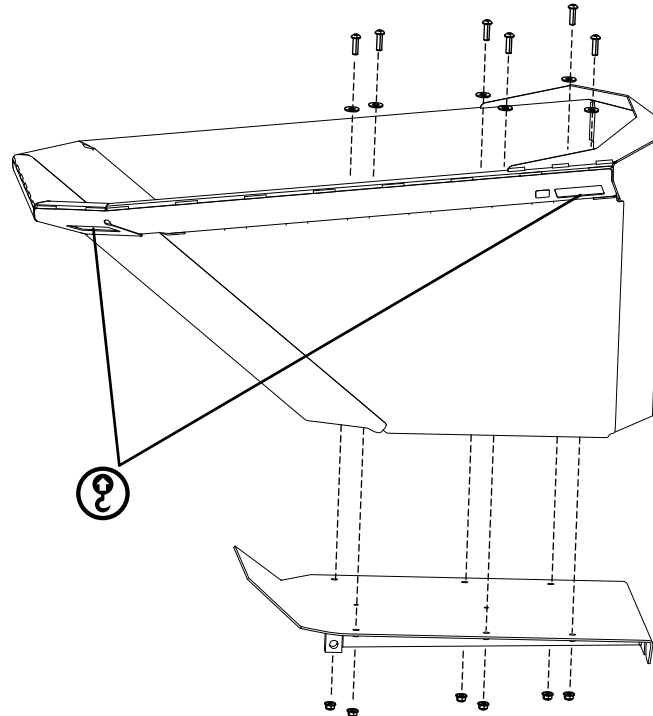

Figuur 1

g347428



⚠ WAARSCHUWING

Een boor gebruiken zonder geschikte oogbescherming kan ertoe leiden dat vuil in het oog belandt en letsel veroorzaakt.

Draag altijd oogbescherming wanneer u boort.

4. Gebruik de nieuwe kuip als een sjabloon en markeer en boor 2 openingen (9/16").

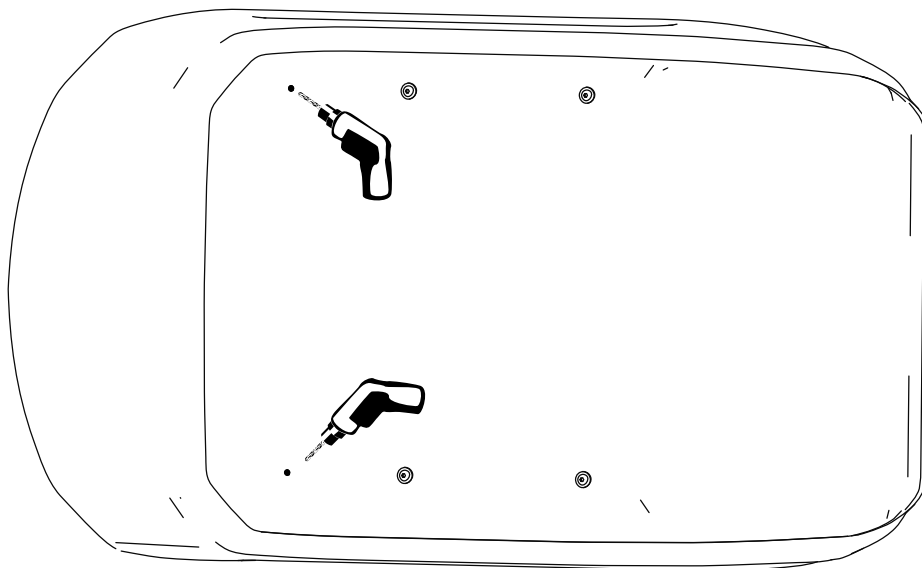

Figuur 2

g322994

5. Monteer het resterende bevestigingsmateriaal om de kuip aan het frame te bevestigen.

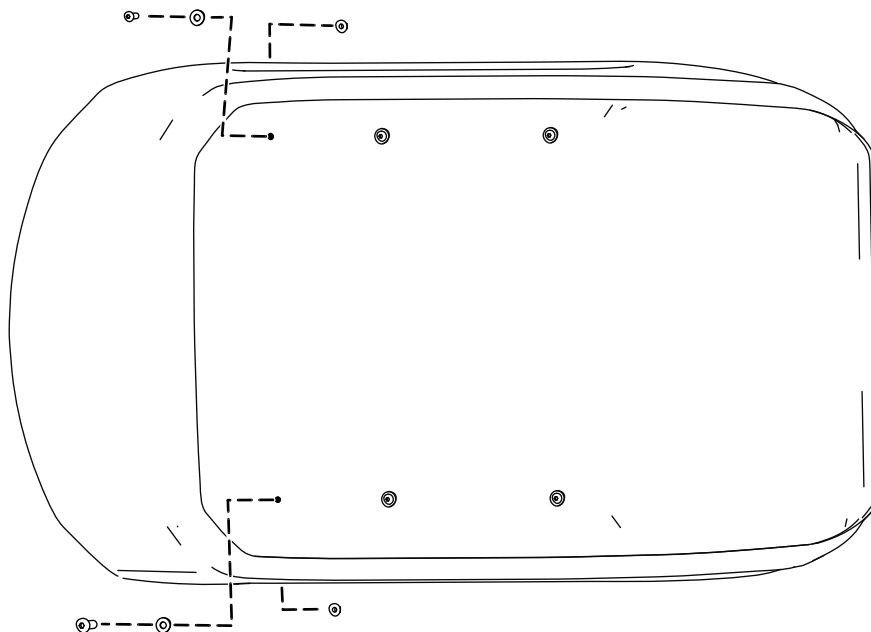

Figuur 3

g322996

6. Draai de bout vast met een torsie van 37 tot 45 N·m.



Count on it.