



**Count on it.**

**Operator's Manual**

# 320-D Compact Tool Carrier

Model No. 22337CP—Serial No. 404340000 and Up

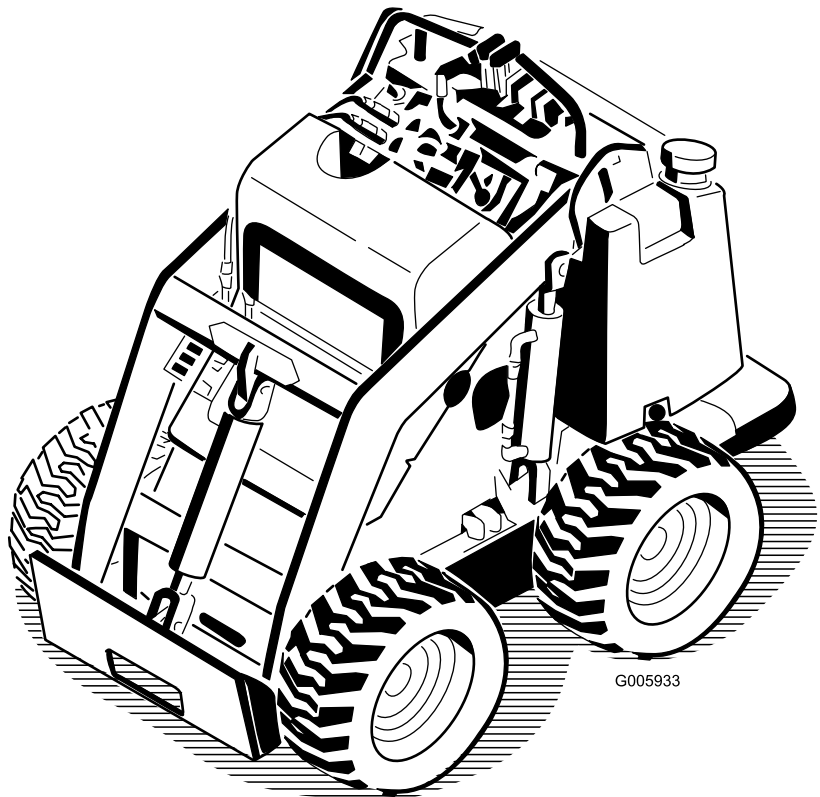

G005933



This product complies with all relevant European directives; for details, please see the separate product specific Declaration of Conformity (DOC) sheet.

It is a violation of California Public Resource Code Section 4442 or 4443 to use or operate the engine on any forest-covered, brush-covered, or grass-covered land unless the engine is equipped with a spark arrester, as defined in Section 4442, maintained in effective working order or the engine is constructed, equipped, and maintained for the prevention of fire.

The enclosed engine owner's manual is supplied for information regarding the US Environmental Protection Agency (EPA) and the California Emission Control Regulation of emission systems, maintenance, and warranty. Replacements may be ordered through the engine manufacturer.

### **⚠ WARNING**

#### **CALIFORNIA Proposition 65 Warning**

**Diesel engine exhaust and some of its constituents are known to the State of California to cause cancer, birth defects, and other reproductive harm.**

**Battery posts, terminals, and related accessories contain lead and lead compounds, chemicals known to the State of California to cause cancer and reproductive harm. Wash hands after handling.**

**Use of this product may cause exposure to chemicals known to the State of California to cause cancer, birth defects, or other reproductive harm.**

## Introduction

This machine is a compact tool carrier intended for use in various earth and materials moving activities for landscaping and construction work. It is designed to operate a wide variety of attachments each of which perform a specialized function. Using this product for purposes other than its intended use could prove dangerous to you and bystanders.

Read this information carefully to learn how to operate and maintain your product properly and to avoid injury and product damage. You are responsible for operating the product properly and safely.

Visit [www.Toro.com](http://www.Toro.com) for product safety and operation training materials, accessory information, help finding a dealer, or to register your product.

Whenever you need service, genuine Toro parts, or additional information, contact an Authorized Service Dealer or Toro Customer Service and have the model and serial numbers of your product ready. **Figure 1** identifies the location of the model and serial numbers on the product. Write the numbers in the space provided.

**Important:** With your mobile device, you can scan the QR code on the serial number decal (if equipped) to access warranty, parts, and other product information.

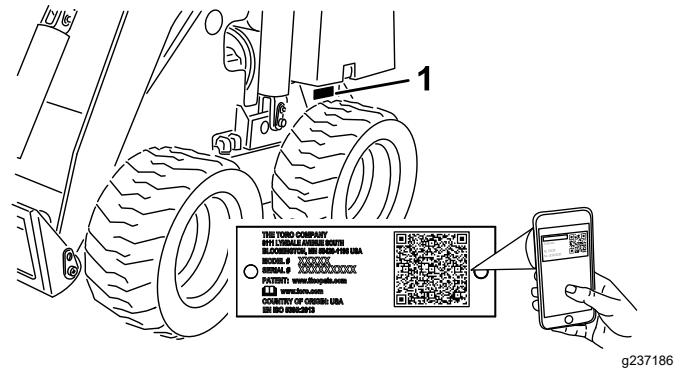

**Figure 1**

1. Model and serial number location

Model No. _____
Serial No. _____

This manual identifies potential hazards and has safety messages identified by the safety-alert symbol (**Figure 2**), which signals a hazard that may cause serious injury or death if you do not follow the recommended precautions.



**Figure 2**

1. Safety-alert symbol

This manual uses 2 words to highlight information. **Important** calls attention to special mechanical information and **Note** emphasizes general information worthy of special attention.

# Contents

Safety .....	4	Changing the Engine Coolant .....	36
General Safety .....	4	Brake Maintenance .....	36
Safety and Instructional Decals .....	5	Testing the Parking Brake .....	36
Setup .....	9	Hydraulic System Maintenance .....	37
1 Installing the Speed-Selector Lever.....	9	Hydraulic System Safety.....	37
2 Checking the Fluid Levels and Tire		Relieving Hydraulic Pressure.....	37
Pressure .....	9	Hydraulic Fluid Specifications.....	37
3 Charging the Battery .....	10	Checking the Hydraulic-Fluid Level.....	38
4 Setting the Engine Speed .....	10	Replacing the Hydraulic Filter .....	38
Product Overview .....	11	Changing the Hydraulic Fluid .....	39
Controls .....	12	Cleaning .....	39
Specifications .....	15	Removing Debris.....	39
Attachments/Accessories .....	15	Storage .....	40
Before Operation .....	15	Storage Safety.....	40
Before Operation Safety .....	15	Storage.....	40
Adding Fuel .....	16	Troubleshooting .....	41
Performing Daily Maintenance.....	17	Schematics .....	45
Adjusting the Thigh Support.....	17		
During Operation .....	18		
During Operation Safety .....	18		
Starting the Engine .....	19		
Driving the Machine .....	19		
Shutting Off the Engine.....	19		
Using Attachments .....	20		
After Operation .....	22		
After Operation Safety .....	22		
Moving a Non-Functioning Machine.....	22		
Hauling the Machine .....	22		
Lifting the Machine .....	24		
Maintenance .....	25		
Maintenance Safety.....	25		
Recommended Maintenance Schedule(s) .....	25		
Pre-Maintenance Procedures .....	26		
Using the Cylinder Locks .....	26		
Accessing Internal Components .....	27		
Lubrication .....	28		
Greasing the Machine.....	28		
Engine Maintenance .....	28		
Engine Safety .....	28		
Servicing the Air Cleaner .....	28		
Servicing the Engine Oil.....	29		
Fuel System Maintenance .....	31		
Draining Water from the Fuel Filter.....	31		
Changing the Fuel Filter.....	31		
Bleeding the Fuel System .....	32		
Draining the Fuel Tank .....	32		
Electrical System Maintenance .....	33		
Electrical System Safety .....	33		
Servicing the Battery.....	33		
Drive System Maintenance .....	35		
Checking the Tire Pressure.....	35		
Checking the Wheel-Lug Nuts .....	35		
Cooling System Maintenance .....	35		
Cooling System Safety .....	35		
Cleaning the Radiator Screen .....	35		
Checking the Engine-Coolant Level.....	35		

# Safety

## **⚠ DANGER**

**There may be buried utility lines in the work area. Digging into them may cause a shock or an explosion.**

**Have the property or work area marked for buried lines and do not dig in marked areas. Contact your local marking service or utility company to have the property marked (for example, in the US, call 811 or in Australia, call 1100 for the nationwide marking service).**

## General Safety

Always follow all safety instructions to avoid serious injury or death.

- Do not carry a load with the arms raised; always carry loads close to the ground.
- Slopes are a major factor related to loss-of-control and tip-over accidents, which can result in severe injury or death. Operating the machine on any slope or uneven terrain requires extra caution.
- Operate the machine up and down slopes with the heavy end of the machine uphill and the load close to the ground. Weight distribution changes with attachments. An empty bucket makes the rear of the machine the heavy end, and a full bucket makes the front of the machine the heavy end. Most other attachments make the front of the machine the heavy end.
- Have the property or work area marked for buried lines and other objects, and do not dig in marked areas.
- Read and understand the content of this *Operator's Manual* before starting the engine.
- Use your full attention while operating the machine. Do not engage in any activity that causes distractions; otherwise, injury or property damage may occur.
- Never allow children or untrained people to operate the machine.
- Keep your hands and feet away from the moving components and attachments.
- Do not operate the machine without the guards and other safety protective devices in place and working on the machine.
- Keep bystanders and children out of the operating area.
- Stop the machine, shut off the engine, and remove the key before servicing, fueling, or unclogging the machine.

Improperly using or maintaining this machine can result in injury. To reduce the potential for injury, comply with these safety instructions and always pay attention to the safety-alert symbol ⚠, which means Caution, Warning, or Danger—personal safety instruction. Failure to comply with these instructions may result in personal injury or death.

# Safety and Instructional Decals



Safety decals and instructions are easily visible to the operator and are located near any area of potential danger. Replace any decal that is damaged or missing.



## Battery Symbols

Some or all of these symbols are on your battery.

- |  |   |
|--|---|
| 1. Explosion hazard                    | 6. Keep bystanders away from the battery.                                       |
| 2. No fire, open flame, or smoking     | 7. Wear eye protection; explosive gases can cause blindness and other injuries. |
| 3. Caustic liquid/chemical burn hazard | 8. Battery acid can cause blindness or severe burns.                            |
| 4. Wear eye protection.                | 9. Flush eyes immediately with water and get medical help fast.                 |
| 5. Read the <i>Operator's Manual</i> . | 10. Contains lead; do not discard   |



93-9084

decal93-9084

1. Lift point/Tie-down point



98-4387

decal98-4387

1. Warning—wear hearing protection.

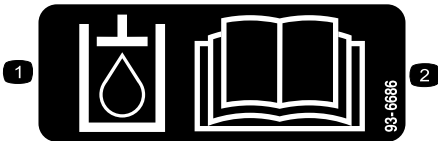

93-6686

decal93-6686

1. Hydraulic fluid
2. Read the *Operator's Manual*.

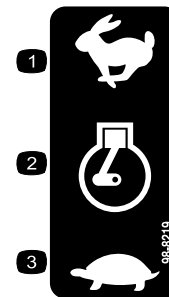

98-8219

decal98-8219

1. Fast
2. Throttle
3. Slow

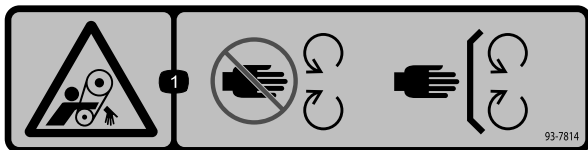

93-7814

decal93-7814

1. Entanglement hazard, belt—stay away from moving parts; keep all guards and shields in place.

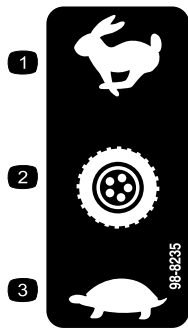

98-8235

decal98-8235

1. Fast
2. Traction drive
3. Slow

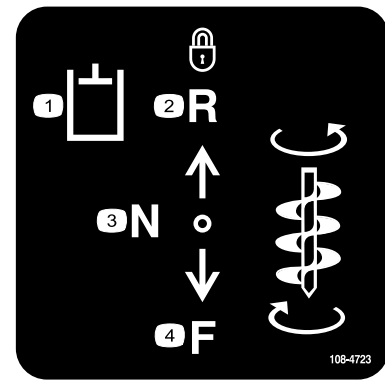

108-4723

decal108-4723

1. Auxiliary hydraulics
2. Locked reverse (detent)
3. Neutral (off)
4. Forward



100-1692

decal100-1692

1. Brake engaged
2. Parking brake
3. Brake disengaged

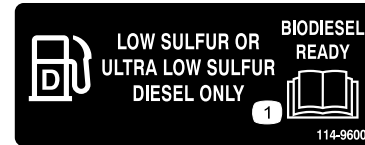

114-9600

decal114-9600

1. Read the *Operator's Manual*.

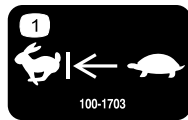

100-1703

decal100-1703

1. Speed selector

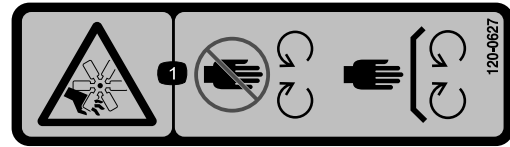

120-0627

decal120-0627

1. Cutting/dismemberment hazard, fan—stay away from moving parts; keep all guards and shields in place.

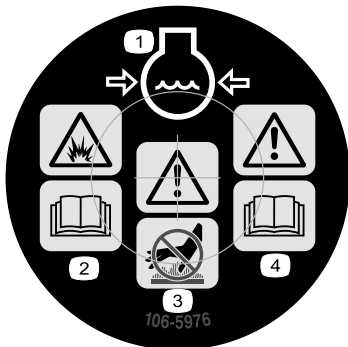

106-5976

decal106-5976

1. Engine coolant under pressure
2. Explosion hazard—read the *Operator's Manual*.
3. Warning—do not touch the hot surface.
4. Warning—read the *Operator's Manual*.

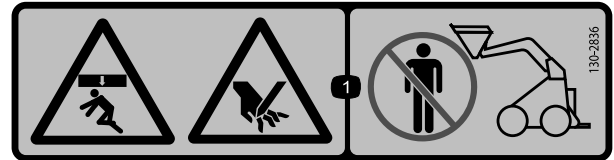

130-2836

decal130-2836

1. Crushing hazard from above; cutting hazard of the hand—keep away from the attachment and the lift arm.



130-2837

decal130-2837

1. Warning—do not carry passengers in the bucket.

**⚠ WARNING: Cancer and Reproductive Harm - www.P65Warnings.ca.gov.**  
For more information, please visit [www.ttcocaprop65.com](http://www.ttcocaprop65.com)

**CALIFORNIA SPARK ARRESTER WARNING**  
Operation of this equipment may create sparks that can start fires around dry vegetation. A spark arrester may be required. The operator should contact local fire agencies for laws or regulations relating to fire prevention requirements.

133-8062

133-8062

decal133-8062

**22337CP QUICK REFERENCE AID** 

**CHECK/SERVICE (daily)**

- OIL LEVEL ENGINE
- OIL LEVEL HYDRAULIC TANK
- BRAKE FUNCTION
- AIR FILTER
- TRACTION PUMP BELT
- GREASE POINTS (12)

SEE OPERATOR'S MANUAL

**FLUID SPECIFICATIONS / CHANGE INTERVALS**

SEE OPERATOR'S MANUAL FOR INITIAL CHANGE	FLUID TYPE	CAPACITY	CHANGE INTERVALS		FILTER PART NO.
			FLUID	FILTER	
A. ENGINE OIL	SAE 10W30, SAE 5W30	3.4 QTS. (3.2 L.)	75 HRS.	75 HRS.	115-8189
B. HYDRAULIC OIL	1000 PREMIUM HYD. FLUID (HYDRAULIC TRANSMISSION OIL)	13 GALS. (94.7 L.)	YEARLY	400 HRS.	54-0110
C. AIR FILTER				200 HRS.	109-3811
D. FUEL FILTER				YEARLY	109-3117
E. FUEL	DIESEL	4.0 GALS. (15.2 L.)			
F. COOLANT	50/50 ETHYLENE GLYCOL/WATER MIX		1500 HRS.		

**COMMON SERVICE PARTS**

V-BELT	100-1979	LH WHEEL ASM	98-2747
QUICK ATTACH ASM	132-6418	RH WHEEL ASM	99-1447

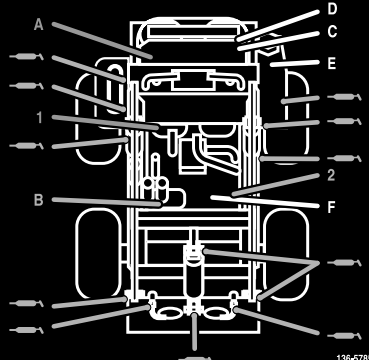

136-5785

decal136-5785

136-5785

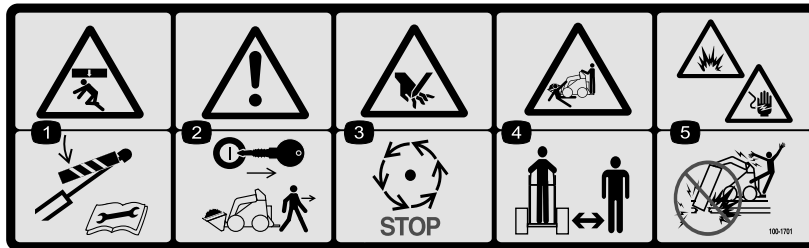

100-1701

decal100-1701

- Crushing hazard from above—install the cylinder lock and read the *Operator's Manual* before performing maintenance.
- Warning—remove the ignition key and lower the loader arms before leaving the machine.
- Cutting hazard of hand—wait for moving parts to stop.
- Crushing/dismemberment hazard of bystanders—keep bystanders away.
- Explosion and electrical shock hazards—do not dig in areas with buried gas or electrical lines.

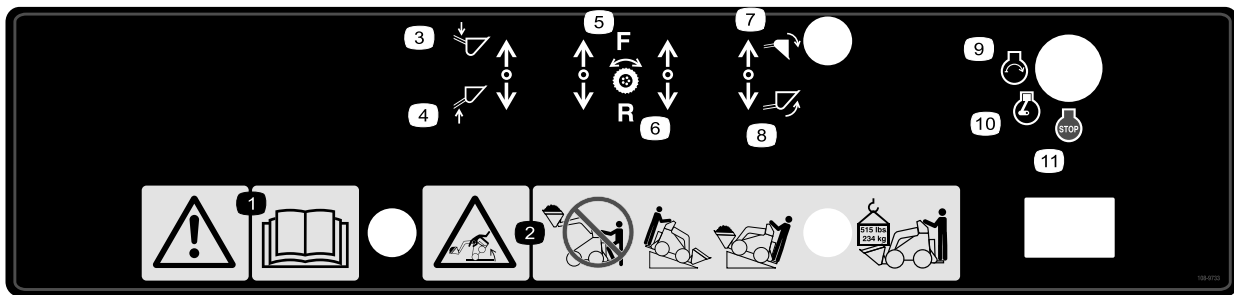

decal108-9733

**108-9733**

- |  |                        |                      |                 |
|--|------------------------|----------------------|-----------------|
| 1. Warning—read the <i>Operator's Manual</i> .   | 4. Arm lift—up         | 7. Bucket tilt— down | 10. Engine—run  |
| 2. Tipping hazard—do not step off operator platform with load raised; always operate with the heavy end of the machine pointed uphill; carry loads low; never jerk the controls; use a steady, even motion; maximum load is 234 kg (515 lb). | 5. Wheel drive—forward | 8. Bucket tilt—up    | 11. Engine—stop |
| 3. Arm lift—down   | 6. Wheel drive—reverse | 9. Engine—start      |                 |



# Setup

## 1

### Installing the Speed-Selector Lever

Parts needed for this procedure:

1	Speed-selector lever
---	----------------------

#### Procedure

1. Remove and discard the nut securing the bolt and lock washer to the speed-selector lever.
2. Secure the lever to the speed-selector valve using the bolt, lock washer, and nut as illustrated in [Figure 3](#).

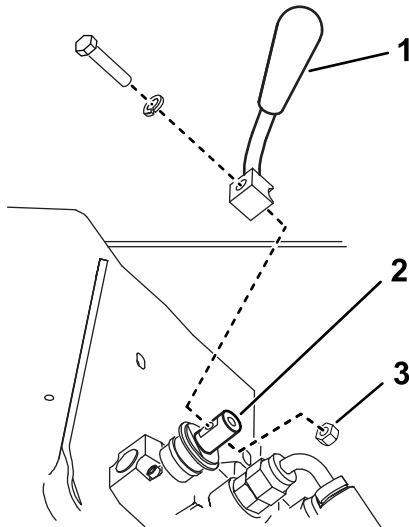

Figure 3

g230938

1. Speed-selector lever
2. Speed-selector valve
3. Nut

## 2

### Checking the Fluid Levels and Tire Pressure

No Parts Required

#### Procedure

Before starting the engine for the first time, check the engine-oil level, hydraulic-fluid level, engine-coolant level, and the tire pressure. Refer to the following sections for more information:

- [Checking the Engine-Oil Level \(page 29\)](#)
- [Checking the Hydraulic-Fluid Level \(page 38\)](#)
- [Checking the Engine-Coolant Level \(page 35\)](#)
- [Checking the Tire Pressure \(page 35\)](#)

# 3

## Charging the Battery

Parts needed for this procedure:

1	Battery (sold separately)
---	---------------------------

### Procedure

Charge and install the battery; refer to [Charging the Battery \(page 34\)](#).

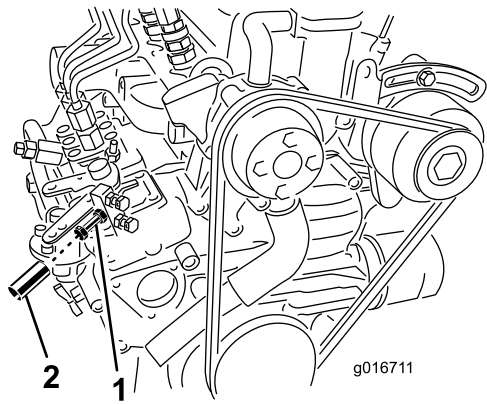

Figure 4

1. Throttle-adjustment screw    2. Aluminum tube

g016711

# 4

## Setting the Engine Speed

### CE Machines Only

Parts needed for this procedure:

1	Aluminum tube
---	---------------

### Procedure

If you are setting up this machine for use in the European Community (CE), you must permanently adjust the engine speed so that it is no more than 3,200 rpm, as follows:

1. Start the engine and run it at half throttle for 5 to 10 minutes to warm it up.

**Important:** The engine must be warm before making this adjustment.

2. Move the throttle to the FAST position.
3. Using a tachometer and the throttle-adjustment screw on the engine ([Figure 4](#)), set the engine speed to 3,200 rpm maximum, then tighten the jam nut on the adjusting screw.

**Important:** If the engine speed exceeds 3,200 rpm, the engine is not in compliance with CE regulations and cannot be legally sold or used in the European Community.

4. Shut off the engine.
  5. Slide an aluminum tube over the throttle-adjustment screw and jam nut ([Figure 4](#)) and crimp it down over the screw so that the screw cannot be adjusted again.
- Important:** The tube must be fully over the jam nut to prevent access to it.
6. Close the rear-access cover and secure it with the lanyard fastener.

# Product Overview

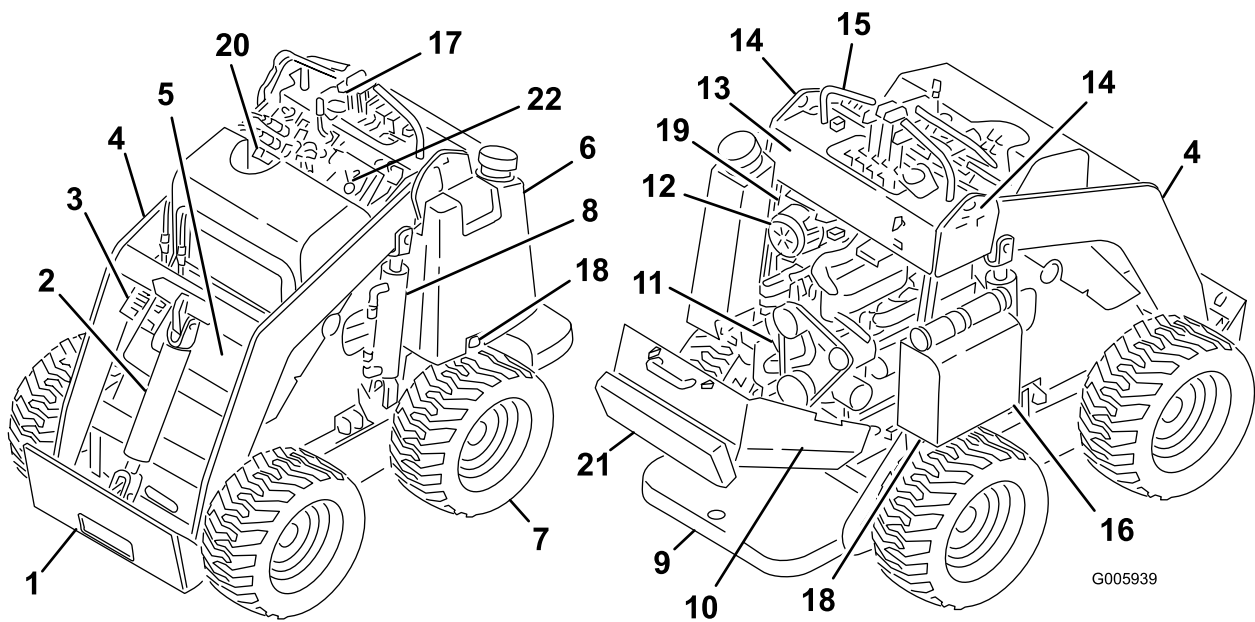

Figure 5

- |                                 |  |   |                          |
|---------------------------------|--|---|--------------------------|
| 1. Mount plate                  | 7. Wheel   | 13. Control panel                               | 19. Parking-brake lever  |
| 2. Tilt cylinder                | 8. Lift cylinder   | 14. Lift points                                 | 20. Radiator-fill cap    |
| 3. Auxiliary-hydraulic couplers | 9. Operator platform<br>(removable counterweight<br>not shown) | 15. Handle                                      | 21. Thigh support        |
| 4. Loader arms                  | 10. Rear-access cover (open)                                   | 16. Battery                                     | 22. Flow-divider control |
| 5. Front-access cover           | 11. Engine   | 17. Indicator lights                            |                          |
| 6. Fuel tank                    | 12. Air filter   | 18. Tow valves (under fuel tank<br>and battery) |                          |

# Controls

Become familiar with all the controls (Figure 6) before you start the engine and operate the machine.

## Control Panel

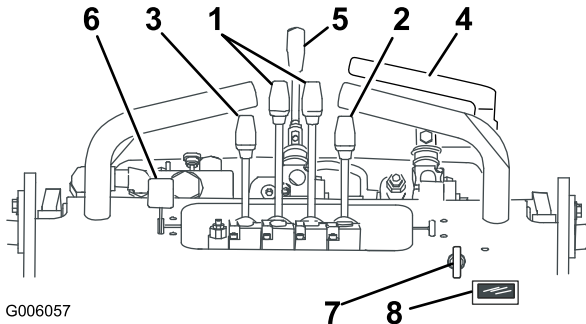

Figure 6

- |                               |                         |
|-------------------------------|-------------------------|
| 1. Traction-control levers    | 5. Speed-selector lever |
| 2. Attachment-tilt lever      | 6. Throttle lever       |
| 3. Loader-arm lever           | 7. Key switch           |
| 4. Auxiliary-hydraulics lever | 8. Hour meter           |

## Key Switch

The key switch, used to start and shut off the engine, has 3 positions: OFF, RUN, and START. Refer to [Starting the Engine \(page 19\)](#).

## Throttle Lever

Move the control forward to increase the engine speed and rearward to decrease speed.

## Traction-Control Levers

- To move forward, move the traction-control levers forward.
- To move rearward, move the traction-control levers rearward.
- To turn, move the lever located on the side you want to turn back toward the NEUTRAL position while keeping the other lever engaged.

**Note:** The farther you move the traction-control levers in either direction, the faster the machine moves in that direction.

- To slow or stop, move the traction-control levers to the NEUTRAL position.

## Attachment-Tilt Lever

- To tilt the attachment forward, slowly push the attachment-tilt lever forward.
- To tilt the attachment rearward, slowly pull the attachment-tilt lever rearward.

## Loader-Arm Lever

- To lower the loader arms, slowly push the loader-arm lever forward.
- To raise the loader arms, slowly pull the loader-arm lever rearward.

## Loader-Valve Lock

The loader-valve lock secures the loader-arm and attachment-tilt levers so that you cannot push them forward. This helps to ensure that no one accidentally lowers the loader arms during maintenance. Secure the loader arms with the lock anytime you need to shut off the machine with the loader arms raised.

To set the lock, pull it back and all the way down against the levers (Figure 7).

**Note:** You must move the levers rearward to engage or disengage the loader-valve lock.

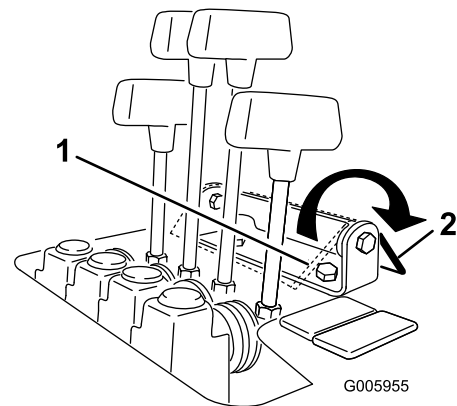

Figure 7

- |                                |                                   |
|--------------------------------|-----------------------------------|
| 1. Loader-valve lock (engaged) | 2. Loader-valve lock (disengaged) |
|--------------------------------|-----------------------------------|

## Auxiliary-Hydraulics Lever

- To operate a hydraulic attachment in the forward direction, slowly pull the auxiliary-hydraulics lever upward and then rearward.
- To operate a hydraulic attachment in the reverse direction, slowly pull the auxiliary-hydraulics lever upward and then push it forward. This is also called the DETENT position because it does not require operator presence.

## Speed-Selector Lever

- To set the traction drive, loader arms, and attachment tilt to high speed and the auxiliary hydraulics to low speed, move the speed-selector lever to the FORWARD position.
- To set the auxiliary hydraulics to high speed and the traction drive, loader arms, and attachment tilt to low speed, move the speed-selector lever to the REARWARD position.

### **▲ WARNING**

If you move the speed-selector lever while the machine is in motion, the machine will either stop suddenly or accelerate quickly. If you operate the machine with the speed-selector lever in an intermediate position, the machine will operate erratically and may be damaged. You could lose control of the machine and injure bystanders or yourself.

- Do not move the speed-selector lever when the machine is in motion.
- Do not operate the machine when the speed selector is in any intermediate position (i.e., any position other than fully forward or fully rearward).

## Hour Meter

The hour meter displays the number of hours of operation logged on the machine.

After 50 hours and every 75 hours thereafter (i.e., 50, 125, 200, etc.) the hour meter displays SVC on the lower left side of the screen to remind you to change the engine oil and perform the required maintenance.

After every 400 hours (i.e., 400, 800, 1200, etc.), the hour meter displays SVC on the lower right side of the screen to remind you to perform the other maintenance procedures based on a 400-hour schedule.

**Note:** These reminders come on starting 3 hours prior to the service interval time and flash at regular intervals for 6 hours.

## Flow-Divider Control

The traction unit hydraulics (i.e., the traction drive, loader arms, and attachment tilt) work on a separate hydraulic circuit from the auxiliary hydraulics for powering attachments; however, the 2 systems share the same hydraulic pumps. Using the flow-divider control (Figure 8), you can vary the speed of the traction unit hydraulics by diverting hydraulic flow to the auxiliary-hydraulics circuit. Therefore, the more hydraulic flow you divert to the auxiliary hydraulics, the slower the traction unit hydraulics move.

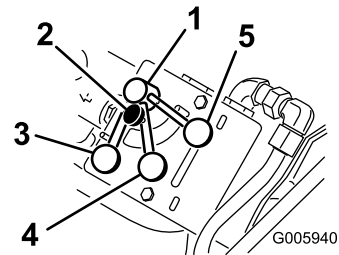

Figure 8

- |                         |                              |
|-------------------------|------------------------------|
| 1. Flow-divider control | 4. 10 to 11 o'clock position |
| 2. Knob                 | 5. 9 o'clock position        |
| 3. 12 o'clock position  |                              |

- Move the flow-divider control to the 12 o'clock position to provide maximum speed to the traction unit hydraulics.  
Use this setting for fast operation of the traction unit.
- Move the flow-divider control between the 12 o'clock and 9 o'clock positions to slow the traction unit hydraulics and fine-tune the speed.  
Use a setting in this range with attachments with hydraulics where you need to both run the attachment and move the traction unit hydraulics, such as the auger, boring unit, hydraulic blade, and tiller.
- Move the control to the 9 o'clock position to transfer all hydraulic flow to the auxiliary hydraulics of the attachment.

In this setting, the traction unit hydraulics do not work. Use this setting with hydraulic attachments that do not require the traction unit hydraulics. The trencher works best if you set it close to 9 o'clock so that the traction unit creeps slowly when trenching.

**Note:** The flow-divider control can be fixed in place by turning the knob on the control clockwise until it contacts the dial (Figure 8).

## Parking-Brake Lever

- To engage the parking brake, rotate the lever down (Figure 9).
- To release the parking brake, rotate the lever up (Figure 9).

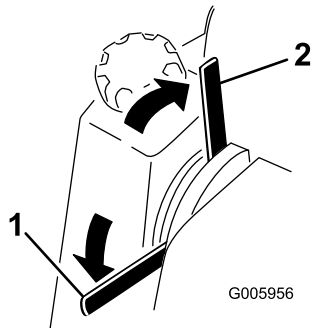

Figure 9

1. Parking-brake lever—engaged
2. Parking-brake lever—disengaged

persists, contact your Authorized Service Dealer for diagnostics and repair.

- Battery Light

This light is on for a few seconds whenever you start the engine. If the battery light is on while the engine is running, the alternator, battery, or electrical system is malfunctioning. Contact your Authorized Service Dealer for diagnostics and repair.

- Glow-Plug Light

This light is on when the key is turned to RUN before starting the engine. The glow-plug light remains on for up to 10 seconds, indicating that the glow plugs are warming the engine. If the glow-plug light is on while the engine is running, the glow plugs are malfunctioning. Contact your Authorized Service Dealer for diagnostics and repair.

---

## Indicator Lights

The indicator lights warn you in the case of a system malfunction and, in the case of the glow-plug light, indicate that the glow plugs are on. Figure 10 illustrates the 4 indicator lights.

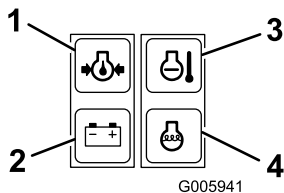

Figure 10

1. Oil-pressure light
2. Battery light
3. Engine-temperature light
4. Glow-plug light

- Engine-Temperature Light

If the engine-temperature light is on, the engine is overheating. Shut off the engine and allow the machine to cool down. Check the coolant level and the belts to the fan and water pump. Fill the coolant as required and replace any worn or slipping belts. If the problem persists, contact your Authorized Service Dealer for diagnostics and repair.

- Oil-Pressure Light

This light is on for a few seconds whenever you start the engine. If the oil-pressure light is on while the engine is running, the engine-oil pressure is low. Shut off the engine and allow the machine to cool down. Check the oil level and fill the crankcase with oil as needed. If the problem

# Specifications

**Note:** Specifications and design are subject to change without notice.

Width	103 cm (41 inches)
Length	152 cm (60 inches)
Height	125 cm (49 inches)
Weight (without attachment or counterweight)	783 kg (1,722 lb)
Weight of the counterweight	75 kg (165 lb)
Operating capacity—with 74.8 kg (165 lb) operator, the standard bucket, and without the counterweight	227 kg (500 lb)
Tipping capacity—with 74.8 kg (165 lb) operator, the standard bucket, and without the counterweight	454 kg (1,000 lb)
Wheelbase	71 cm (28 inches)
Dump height (with standard bucket)	120 cm (47 inches)
Reach—fully raised (with standard bucket)	66 cm (26 inches)
Height to hinge pin (narrow bucket in standard position)	168 cm (66 inches)

## Attachments/Accessories

A selection of Toro approved attachments and accessories is available for use with the machine to enhance and expand its capabilities. Contact your Authorized Service Dealer or authorized Toro distributor or go to [www.Toro.com](http://www.Toro.com) for a list of all approved attachments and accessories.

To ensure optimum performance and continued safety certification of the machine, use only genuine Toro replacement parts and accessories. Replacement parts and accessories made by other manufacturers could be dangerous, and such use could void the product warranty.

# Operation

## Before Operation

### Before Operation Safety

#### General Safety

- Never allow children or untrained people to operate or service the machine. Local regulations may restrict the age or require certified training of the operator. The owner is responsible for training all operators and mechanics.
- Become familiar with the safe operation of the equipment, operator controls, and safety decals.
- Always engage the parking brake (if equipped), shut off the engine, remove the key, wait for all moving parts to stop, and allow the machine to cool before adjusting, servicing, cleaning, or storing the machine.
- Know how to stop the machine and shut off the engine quickly.
- Check that the operator's presence controls, safety switches, and shields are attached and functioning properly. Do not operate the machine unless they are functioning properly.
- Locate the pinch-point areas marked on the machine and attachments; keep your hands and feet away from these areas.
- Before operating the machine with an attachment, ensure that the attachment is properly installed and that it is a genuine Toro attachment. Read all the attachment manuals.
- Evaluate the terrain to determine what accessories and attachments you need to properly and safely perform the job.
- Have the property or work area marked for buried lines and other objects, and do not dig in marked areas; note the location of unmarked objects and structures, such as underground storage tanks, wells, and septic systems.
- Inspect the area where you will use the equipment and remove all debris.
- Ensure that the area is clear of bystanders before operating the machine. Stop the machine if anyone enters the area.

## Fuel Safety

- Use extra care when handling fuel. It is flammable and its vapors are explosive.
- Extinguish all cigarettes, cigars, pipes, and other sources of ignition.
- Use only an approved fuel container.
- Do not remove the fuel cap or fill the fuel tank while the engine is running or hot.
- Do not add or drain fuel in an enclosed space.
- Do not store the machine or fuel container where there is an open flame, spark, or pilot light, such as on a water heater or other appliance.
- If you spill fuel, do not attempt to start the engine; avoid creating any source of ignition until the fuel vapors have dissipated.
- Do not fill containers inside a vehicle or on a truck or trailer bed with a plastic liner. Always place containers on the ground, away from your vehicle before filling.
- Remove the equipment from the truck or trailer and refuel it while it is on the ground. If this is not possible, then refuel from a portable container rather than a fuel-dispenser nozzle.
- Keep the fuel-dispenser nozzle in contact with the rim of the fuel tank or container opening at all times until fueling is complete. Do not use a nozzle lock-open device.

## Adding Fuel

### Recommended Fuel

Use only clean, fresh diesel fuel or biodiesel fuels with low (<500 ppm) or ultra low (<15 ppm) sulfur content. The minimum cetane rating should be 40. Purchase fuel in quantities that you can use within 180 days to ensure fuel freshness.

Use summer-grade diesel fuel (No. 2-D) at temperatures above -7°C (20°F) and winter grade (No. 1-D or No. 1-D/2-D blend) below that temperature. Using winter-grade fuel at lower temperatures provides lower flash point and cold flow characteristics, which eases starting and reduces fuel filter plugging.

Using summer-grade fuel above -7°C (20°F) contributes toward longer fuel pump life and increased power compared to winter-grade fuel.

***Important:*** Do not use kerosene or gasoline instead of diesel fuel. Failure to observe this caution will damage the engine.

### Biodiesel Ready

This machine can also use a biodiesel blended fuel of up to B20 (20% biodiesel, 80% petrodiesel). The petrodiesel portion should be low or ultra low sulfur. Observe the following precautions:

- The biodiesel portion of the fuel must meet specification ASTM D6751 or EN14214.
- The blended fuel composition should meet ASTM D975 or EN590.
- Painted surfaces may be damaged by biodiesel blends.
- Use B5 (biodiesel content of 5%) or lesser blends in cold weather.
- Monitor seals, hoses, gaskets in contact with fuel as they may degrade over time.
- Fuel filter plugging may occur for a time after converting to biodiesel blends.
- Contact your distributor for more information on biodiesel.



## Filling the Fuel Tank(s)

1. Park the machine on a level surface, engage the parking brake (if equipped), and lower the loader arms.
2. Shut off the engine, remove the key, and allow the engine to cool.
3. Clean around the fuel-tank cap and remove it (Figure 11).

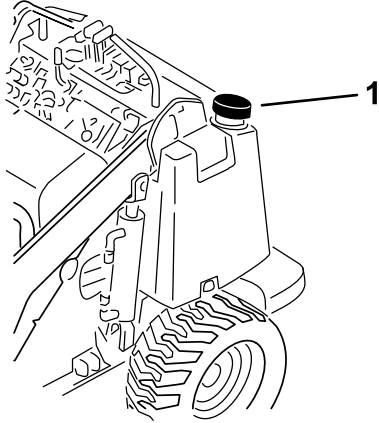

Figure 11

g237886

1. Fuel-tank cap

4. Fill the tank to about 2.5 cm (1 inch) below the top of the tank, not the filler neck, with fuel.

**Important:** This space in the tank allows fuel to expand. Do not fill the fuel tank completely full.

5. Install the fuel-tank cap securely, turning it until it clicks.
6. Wipe up any spilled fuel.

## Performing Daily Maintenance

Before starting the machine each day, perform the Each Use/Daily procedures listed in the [Maintenance \(page 25\)](#).

**Important:** Check the hydraulic-fluid level and bleed the fuel system before starting the engine for the first time; refer to [Checking the Hydraulic-Fluid Level \(page 38\)](#) and [Bleeding the Fuel System \(page 32\)](#).

## Adjusting the Thigh Support

To adjust the thigh support (Figure 12), loosen the knobs and raise or lower the support pad to the desired height. You can also obtain additional adjustment by loosening the nut securing the pad to the adjustment plate and moving the plate up or down as needed. Tighten all fasteners securely when finished.

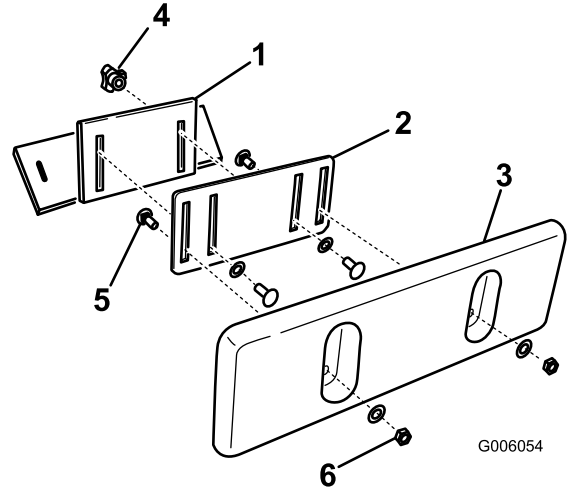

Figure 12

g006054

1. Thigh-support bracket
2. Adjustment plate
3. Thigh-support pad
4. Knob and flat washer
5. Carriage bolt
6. Locknut and flat washer

# *During Operation*

## During Operation Safety

### General Safety

- Do not carry a load with the arms raised. Always carry loads close to the ground.
- Do not exceed the rated operating capacity, as the machine may become unstable, which may result in loss of control.
- Use only Toro-approved attachments and accessories. Attachments can change the stability and the operating characteristics of the machine.
- For machines with a platform:
  - Lower the loader arms before stepping off the platform.
  - Do not try to stabilize the machine by putting your foot on the ground. If you lose control of the machine, step off the platform and away from the machine.
  - Do not place your feet under the platform.
  - Do not move the machine unless you are standing with both feet on the platform and your hands are holding onto the reference bars.
- Use your full attention while operating the machine. Do not engage in any activity that causes distractions; otherwise, injury or property damage may occur.
- Look behind and down before backing up to ensure that the path is clear.
- Never jerk the controls; use a steady motion.
- The owner/user can prevent and is responsible for accidents that may cause personal injury or property damage.
- Wear appropriate clothing including gloves, eye protection, long pants, substantial slip-resistant footwear, and hearing protection. Tie back long hair and do not wear loose clothing or loose jewelry.
- Do not operate the machine when you are tired, ill, or under the influence of alcohol or drugs.
- Never carry passengers and keep pets and bystanders away from the machine
- Operate the machine only in good light, keeping away from holes and hidden hazards.
- Ensure that all the drives are in neutral and engage the parking brake (if equipped) before starting the engine. Start the engine only from the operator's position.
- Use care when approaching blind corners, shrubs, trees, or other objects that may obscure vision.
- Slow down and use caution when making turns and crossing roads and sidewalks. Watch for traffic.
- Stop the attachment when you are not working.
- Stop the machine, turn off the engine, remove the key, and inspect the machine if you strike an object. Make any necessary repairs before resuming operation.
- Never run an engine in an enclosed area.
- Never leave a running machine unattended.
- Before leaving the operating position, do the following:
  - Park the machine on a level surface.
  - Lower the loader arms and disengage the auxiliary hydraulics.
  - Engage the parking brake (if equipped).
  - Shut off the engine and remove the key.
- Do not operate the machine when there is the risk of lightning.
- Operate the machine only in areas where there is sufficient clearance for you to safely maneuver. Be aware of obstacles in close proximity to you. Failure to maintain adequate distance from trees, walls, and other barriers may result in injury as the machine backs up during operation if you are not attentive to the surroundings.
- Check for overhead clearance (i.e., electrical wires, branches, and doorways) before driving under any objects and do not contact them.
- Do not overfill the attachment and always keep the load level when raising the loader arms. Items in the attachment could fall and cause injury.

### Slope Safety

- **Operate the machine up and down slopes with the heavy end of the machine uphill.** Weight distribution changes with attachments. An empty bucket makes the rear of the machine the heavy end, and a full bucket makes the front of the machine the heavy end. Most other attachments make the front of machine the heavy end.
- Raising the loader arms on a slope affects the stability of the machine. Keep the loader arms in the lowered position when on slopes.
- Slopes are a major factor related to loss of control and tip-over accidents, which can result in severe injury or death. Operating the machine on any slope or uneven terrain requires extra caution.
- Establish your own procedures and rules for operating on slopes. These procedures must include surveying the site to determine which slopes are safe for machine operation. Always

use common sense and good judgment when performing this survey.

- Slow down and use extra care on hillsides. Ground conditions can affect the stability of the machine.
  - Avoid starting or stopping on a slope. If the machine loses traction, proceed slowly, straight down the slope.
  - Avoid turning on slopes. If you must turn, turn slowly and keep the heavy end of the machine uphill.
  - Keep all movements on slopes slow and gradual. Do not make sudden changes in speed or direction.
  - If you feel uneasy operating the machine on a slope, do not do it.
  - Watch for holes, ruts, or bumps, as uneven terrain could overturn the machine. Tall grass can hide obstacles.
  - Use caution when operating on wet surfaces. Reduced traction could cause sliding.
  - Evaluate the area to ensure that the ground is stable enough to support the machine.
  - Use caution when operating the machine near the following:
    - Drop-offs
    - Ditches
    - Embankments
    - Bodies of water
- The machine could suddenly roll over if a track goes over the edge or the edge caves in. Maintain a safe distance between the machine and any hazard.
- Do not remove or add attachments on a slope.
  - Do not park the machine on a hillside or slope.

## Starting the Engine

1. Stand on the platform.
2. Ensure that the auxiliary hydraulics lever is in the NEUTRAL position.
3. Move the throttle lever midway between the SLOW and FAST positions.
4. Insert the key into the key switch and turn it to the RUN position.  
**Note:** The battery, oil pressure, and glow-plug lights come on.
5. When the glow-plug light turns off, turn the key to the START position. When the engine starts, release the key.

**Note:** A warm engine may be started without waiting for the light to turn off.

**Important:** Do not engage the starter for more than 10 seconds at a time. If the engine fails to start, wait 30 seconds for the starter to cool down between attempts. Failure to follow these instructions could burn out the starter motor.

6. Move the throttle lever to the FAST setting.

**Important:** Running the engine at high speeds when the hydraulic system is cold (i.e., when the air temperature is at or below freezing) could damage the hydraulic system. When starting the engine in cold conditions, allow it to run in the middle throttle position for 2 to 5 minutes before moving the throttle to the FAST position.

**Note:** If the outdoor temperature is below freezing, store the machine in a garage to keep it warmer and to aid in starting.

## Driving the Machine

Use the traction controls to move the machine. The farther you move the traction controls in any direction, the faster the machine moves in that direction. Release the traction controls to stop the machine.

The throttle control regulates the engine speed as measured in rpm (revolutions per minute). Place the throttle lever in the FAST position for best performance. You can, however, use the throttle position to operate at slower speeds.

## Shutting Off the Engine

1. Park the machine on a level surface, engage the parking brake (if equipped), and lower the loader arms.
  2. Ensure that the auxiliary hydraulics lever is in the NEUTRAL position.
  3. Move the throttle lever to the SLOW position.
  4. If the engine has been working hard or is hot, let it idle for a minute before turning the key switch to the OFF position.
- Note:** This helps to cool the engine before you shut it off. In an emergency, you can shut off the engine immediately.
5. Turn the key switch to the OFF position and remove the key.

## ⚠ CAUTION

Children or bystanders may be injured if they move or attempt to operate the machine while it is unattended.

Always remove the key and engage the parking brake when leaving the machine unattended.

## Using Attachments

### Installing an Attachment

**Important:** Use only Toro-approved attachments. Attachments can change the stability and the operating characteristics of the machine. The warranty of the machine may be voided if you use the machine with unapproved attachments.

**Important:** Before installing the attachment, ensure that the mount plates are free of any dirt or debris and that the pins rotate freely. If the pins do not rotate freely, grease them.

1. Position the attachment on a level surface with enough space behind it to accommodate the machine.
2. Start the engine.
3. Tilt the attachment mount plate forward.
4. Position the mount plate into the upper lip of the attachment receiver plate (Figure 13).

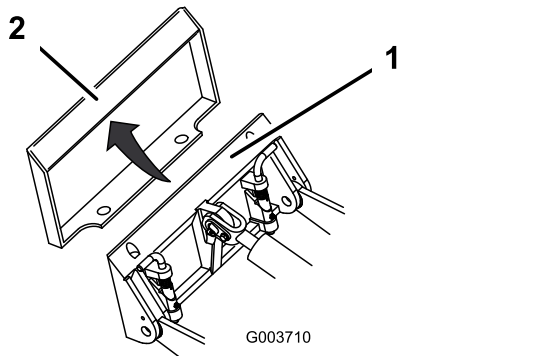

Figure 13

1. Mount plate
2. Receiver plate

5. Raise the loader arms while tilting back the mount plate at the same time.

**Important:** Raise the attachment enough to clear the ground and tilt the mount plate all the way back.

6. Shut off the engine and remove the key.
7. Engage the quick-attach pins, ensuring that they are fully seated in the mount plate (Figure 14).

**Important:** If the pins do not rotate to the engaged position, the mount plate is not fully aligned with the holes in the attachment receiver plate. Check the receiver plate and clean it if necessary.

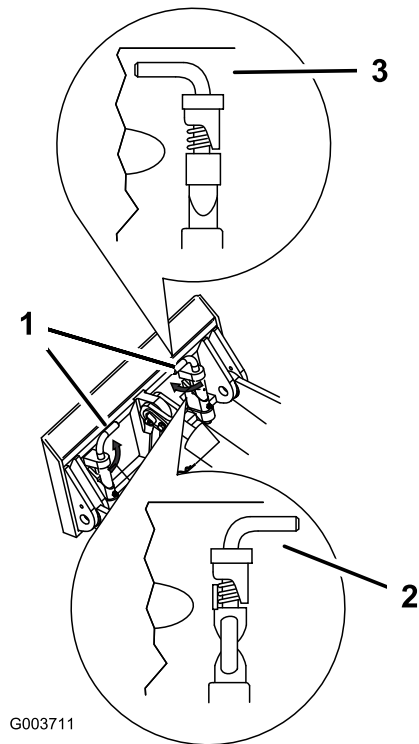

Figure 14

1. Quick-attach pins (engaged position)
2. Disengaged position
3. Engaged position

## ⚠ WARNING

If you do not fully seat the quick-attach pins through the attachment mount plate, the attachment could fall off the machine, crushing you or bystanders.

Ensure that the quick-attach pins are fully seated in the attachment mount plate.

## Connecting the Hydraulic Hoses

### ⚠ WARNING

Hydraulic fluid escaping under pressure can penetrate skin and cause injury. Fluid injected into the skin must be surgically removed within a few hours by a doctor familiar with this form of injury; otherwise, gangrene may result.

- Ensure that all hydraulic-fluid hoses and lines are in good condition and all hydraulic connections and fittings are tight before applying pressure to the hydraulic system.
- Keep your body and hands away from pinhole leaks or nozzles that eject high-pressure hydraulic fluid.
- Use cardboard or paper to find hydraulic leaks; never use your hands.

### ⚠ CAUTION

Hydraulic couplers, hydraulic lines/valves, and hydraulic fluid may be hot. If you contact hot components, you may be burned.

- Wear gloves when operating the hydraulic couplers.
- Allow the machine to cool before touching hydraulic components.
- Do not touch hydraulic fluid spills.

If the attachment requires hydraulics for operation, connect the hydraulic hoses as follows:

1. Shut off the engine and remove the key.
2. Move the auxiliary-hydraulics lever forward, backward, and back to the NEUTRAL position to relieve pressure at the hydraulic couplers.
3. Remove the protective covers from the hydraulic connectors on the machine.
4. Ensure that all foreign matter is cleaned from the hydraulic connectors.
5. Push the attachment male connector into the female connector on the machine.

**Note:** When you connect the attachment male connector first, you relieve any pressure built up in the attachment.

6. Push the attachment female connector onto the male connector on the machine.

7. Confirm that the connection is secure by pulling on the hoses.

## Removing an Attachment

1. Park the machine on a level surface.
2. Lower the attachment to the ground.
3. Shut off the engine and remove the key.
4. Disengage the quick-attach pins by turning them to the outside.
5. If the attachment uses hydraulics, move the auxiliary-hydraulics lever forward, backward, and back to the NEUTRAL position to relieve pressure at the hydraulic couplers.
6. If the attachment uses hydraulics, slide the collars back on the hydraulic couplers and disconnect them.

**Important:** Connect the attachment hoses together to prevent hydraulic system contamination during storage.

7. Install the protective covers onto the hydraulic couplers on the machine.
8. Start the engine, tilt the mount plate forward, and back the machine away from the attachment.

# After Operation

## After Operation Safety

- Shut off the engine, remove the key, wait for all movement to stop, and allow the machine to cool before adjusting, cleaning, storing, or servicing it.
- Clean debris from the attachments, drives, mufflers, and engine to help prevent fires. Clean up oil or fuel spills.
- Keep all parts in good working condition and all hardware tightened.
- Do not touch parts that may be hot from operation. Allow them to cool before attempting to maintain, adjust, or service the machine.
- Use care when loading or unloading the machine into a trailer or truck.

## Moving a Non-Functioning Machine

**Important:** Do not tow or pull the machine without first opening the tow valves, or you will damage the hydraulic system.

1. Shut off the engine and remove the key.
2. Remove the plug covering each tow valve (Figure 15).

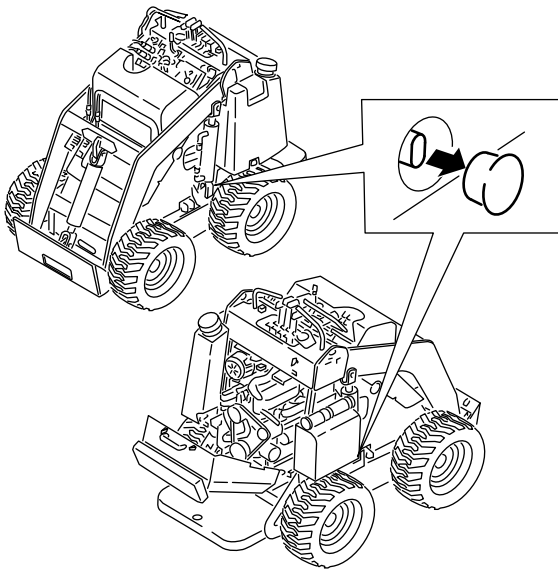

Figure 15

g237902

3. Loosen the jam nut on each tow valve.
4. Turn each valve counterclockwise 1 turn with a hex wrench to open them.
5. Tow the machine as required.

**Important:** Do not exceed 4.8 km/h (3 mph) when towing.

6. After repairing the machine, close the tow valves and tighten the jam nuts.

**Important:** Do not overtighten the tow valves.

7. Replace the plugs.

## Hauling the Machine

Use a heavy-duty trailer or truck to haul the machine. Use a full-width ramp. Ensure that the trailer or truck has all the necessary brakes, lighting, and marking as required by law. Please carefully read all the safety instructions. Knowing this information could help you or bystanders avoid injury. Refer to your local ordinances for trailer and tie-down requirements.

### ⚠ WARNING

Driving on the street or roadway without turn signals, lights, reflective markings, or a slow-moving-vehicle emblem is dangerous and can lead to accidents causing personal injury.

Do not drive the machine on a public street or roadway.

## Selecting a Trailer

### ⚠ WARNING

Loading a machine onto a trailer or truck increases the possibility of tip-over and could cause serious injury or death (Figure 16).

- Use only full-width ramps.
- Ensure that the length of ramp is at least 4 times as long as the height of the trailer or truck bed to the ground. This ensures that ramp angle does not exceed 15 degrees on flat ground.

## Loading the Machine

### ⚠ WARNING

Loading a machine onto a trailer or truck increases the possibility of tip-over and could cause serious injury or death.

- Use extreme caution when operating a machine on a ramp.
- Load and unload the machine with the heavy end up the ramp.
- Avoid sudden acceleration or deceleration while driving the machine on a ramp as this could cause a loss of control or a tip-over situation.

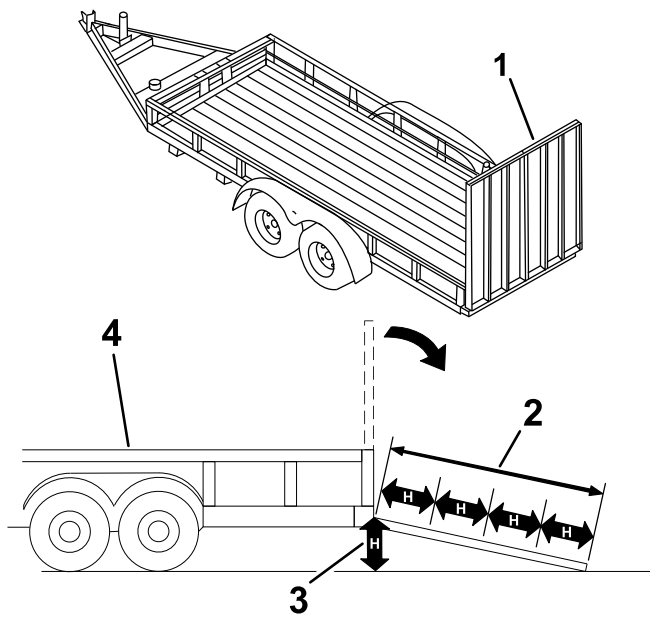
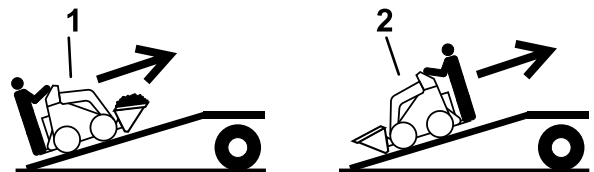

Figure 16

g229507

- |   |   |
|---|---|
| 1. Full-width ramp(s) in stowed position  | 3. H=height of the trailer or truck bed to the ground |
| 2. Ramp is at least 4 times as long as the height of the trailer or truck bed to the ground | 4. Trailer  |

1. If using a trailer, connect it to the towing vehicle and connect the safety chains.
2. If applicable, connect the trailer brakes.
3. Lower the ramp(s).
4. Lower the loader arms.
5. Load the machine onto the trailer with the heavy end up the ramp, carrying loads low (Figure 17).
  - If the machine has a **full** load-bearing attachment (e.g., bucket) or a non-load-bearing attachment (e.g., trencher), drive the machine forward up the ramp.
  - If the machine has an **empty** load-bearing attachment or no attachment, back the machine up the ramp.



g237904

Figure 17

1. Machine with full attachment or non-load-bearing attachment—drive the machine forward up the ramp(s).
2. Machine with empty or no attachment—back the machine up the ramp(s).

6. Lower the loader arms all the way down.
7. Engage the parking brake (if equipped), shut off the engine, and remove the key.
8. Use the metal tie-down loops on the machine to securely fasten the machine to the trailer or truck with straps, chains, cable, or ropes (Figure 18). Refer to local regulations for tie-down requirements.

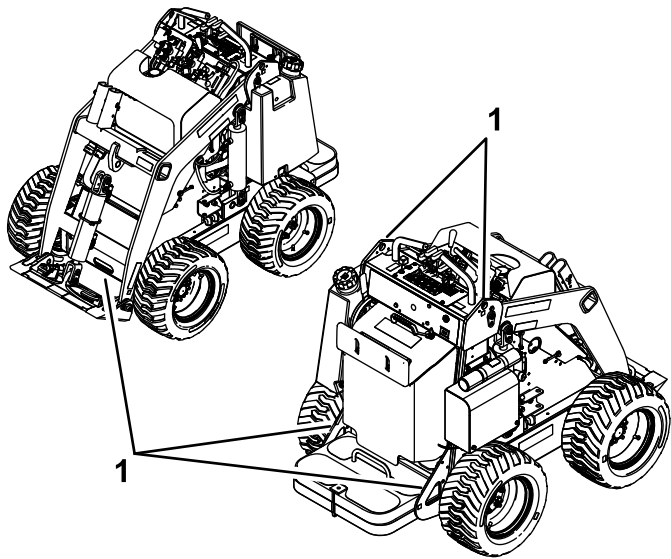

g248506

**Figure 18**

1. Tie-down loops

## Unloading the Machine

1. Lower the ramp(s).
2. Unload the machine from the trailer with the heavy end up the ramp, carrying loads low ([Figure 19](#)).
  - If the machine has a **full** load-bearing attachment (e.g., bucket) or a non-load-bearing attachment (e.g., trencher), back it down the ramp.
  - If the machine has an **empty** load-bearing attachment or no attachment, drive it forward down the ramp.

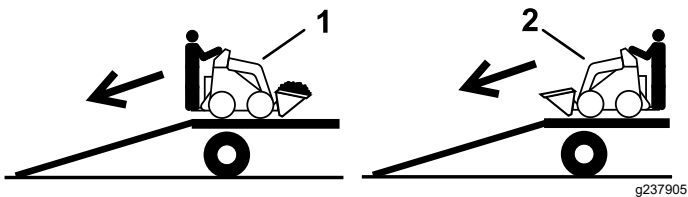

g237905

**Figure 19**

1. Machine with full attachment or non-load-bearing attachment—back the machine down the ramp(s).
2. Machine with empty or no attachment—drive the machine forward down the ramp(s).

## Lifting the Machine

You can lift the machine using the tie-down/lift loops as lift points; refer to [Figure 18](#).



# Maintenance

**Note:** Determine the left and right sides of the machine from the normal operating position.

## ⚠ CAUTION

If you leave the key in the switch, someone could accidentally start the engine and seriously injure you or other bystanders.

Remove the key from the switch before you perform any maintenance.

## Maintenance Safety

- Park the machine on a level surface, disengage the auxiliary hydraulics, lower the attachment, engage the parking brake (if equipped), shut off the engine, and remove the key. Wait for all movement to stop and allow the machine to cool before adjusting, cleaning, storing, or repairing it.
- Clean up oil or fuel spills.
- Do not allow untrained personnel to service the machine.
- Use jack stands to support the components when required.
- Carefully release pressure from components with stored energy; refer to [Relieving Hydraulic Pressure \(page 37\)](#).
- Disconnect the battery before making any repairs; refer to [Servicing the Battery \(page 33\)](#).
- Keep your hands and feet away from the moving parts. If possible, do not make adjustments with the engine running.
- Keep all parts in good working condition and all hardware tightened. Replace all worn or damaged decals.
- Do not tamper with the safety devices.
- Use only Toro-approved attachments. Attachments can change the stability and the operating characteristics of the machine. You may void the warranty if you use the machine with unapproved attachments.
- Use only genuine Toro replacement parts.
- If any maintenance or repair requires the loader arms to be in the raised position, secure the arms in the raised position with the hydraulic-cylinder lock(s).

## Recommended Maintenance Schedule(s)

Maintenance Service Interval	Maintenance Procedure
After the first 8 hours	<ul style="list-style-type: none"> <li>• Torque the wheel-lug nuts.</li> <li>• Replace the hydraulic filter.</li> </ul>
After the first 50 hours	<ul style="list-style-type: none"> <li>• Change the engine oil and filter.</li> </ul>
Before each use or daily	<ul style="list-style-type: none"> <li>• Grease the machine. (Grease immediately after every washing.)</li> <li>• Check the engine-oil level.</li> <li>• Drain water from the fuel filter.</li> <li>• Check the tire pressure.</li> <li>• Check and clean the radiator screen</li> <li>• Check the engine-coolant level.</li> <li>• Test the parking brake.</li> <li>• Remove debris from the machine.</li> <li>• Check for loose fasteners.</li> </ul>
Every 25 hours	<ul style="list-style-type: none"> <li>• Check the hydraulic lines for leaks, loose fittings, kinked lines, loose mounting supports, wear, weather, and chemical deterioration.</li> <li>• Check the hydraulic-fluid level.</li> </ul>
Every 75 hours	<ul style="list-style-type: none"> <li>• Change the engine oil and filter (more frequently when operating conditions are extremely dusty or sandy).</li> <li>• Check the battery cable connections.</li> <li>• Clean the battery.</li> </ul>
Every 100 hours	<ul style="list-style-type: none"> <li>• Torque the wheel-lug nuts.</li> </ul>

Maintenance Service Interval	Maintenance Procedure
Every 200 hours	<ul style="list-style-type: none"> <li>Service the air cleaner. (Service more frequently if conditions are extremely dusty or sandy.)</li> </ul>
Every 400 hours	<ul style="list-style-type: none"> <li>Replace the hydraulic filter.</li> </ul>
Every 1,500 hours	<ul style="list-style-type: none"> <li>Replace all moving hydraulic hoses.</li> </ul>
Yearly	<ul style="list-style-type: none"> <li>Change the fuel filter.</li> <li>Change the engine coolant.</li> <li>Change the hydraulic fluid.</li> </ul>
Yearly or before storage	<ul style="list-style-type: none"> <li>Touch up chipped paint.</li> </ul>

**Important:** Refer to your engine owner's manual for additional maintenance procedures.

## Pre-Maintenance Procedures

### Using the Cylinder Locks

#### ⚠ WARNING

The loader arms may lower when in the raised position, crushing anyone under them.

Install the cylinder lock(s) before performing maintenance that requires raised loader arms.

#### Installing the Cylinder Locks

1. Remove the attachment.
2. Raise the loader arms to the fully raised position.
3. Shut off the engine and remove the key.
4. Position a cylinder lock over each lift-cylinder rod (Figure 20).

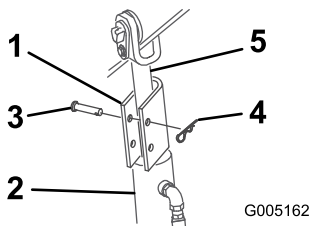

Figure 20

1. Cylinder lock
2. Lift cylinder
3. Hairpin cotter
4. Clevis pin
5. Lift-cylinder rod

### Removing and Storing the Cylinder Locks

**Important:** Remove the cylinder locks from the rods and fully secure them in the storage position before operating the machine.

1. Start the engine.
2. Raise the loader arms to the fully raised position.
3. Shut off the engine and remove the key.
4. Remove the clevis pin and cotter pin securing each cylinder lock.
5. Remove the cylinder locks.
6. Lower the loader arms.
7. Install the cylinder locks over the hydraulic hoses and secure them with the clevis pins and cotter pins (Figure 21).

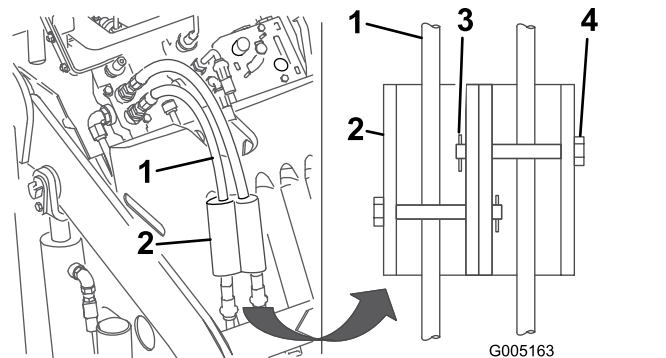

Figure 21

1. Hydraulic hoses
2. Cylinder locks
3. Hairpin cotter
4. Clevis pin

5. Secure each cylinder lock with a clevis pin and cotter pin (Figure 20).
6. **Slowly** lower the loader arms until the cylinder locks contact the cylinder bodies and rod ends.

# Accessing Internal Components

## **⚠ WARNING**

Opening or removing covers, hoods, and screens while the engine is running could allow you to contact moving parts, seriously injuring you.

Before opening any of the covers, hoods, and screens, shut off the engine, remove the key from the key switch, and allow the engine to cool.

## Removing the Front-Access Cover

1. Park the machine on a level surface and engage the parking brake.
2. Raise the loader arms and install the cylinder locks.

**Note:** If you must remove the front-access cover without raising the loader arms, be very careful not to damage the cover or hydraulic hoses as you maneuver the cover out from under the arms.

3. Shut off the engine and remove the key.
4. Release the 2 locking tabs (Figure 22, top, left tab illustrated).

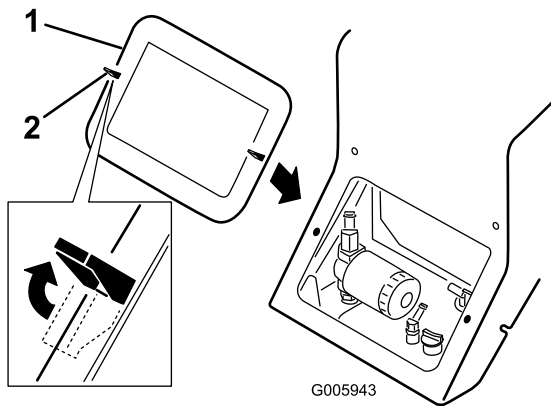

**Figure 22**

1. Cover
2. Locking tab

5. Pull the cover off the machine.
6. When finished, replace the front-access cover and secure it with the 2 locking tabs.

## Opening the Rear-Access Cover

1. Park the machine on a level surface, engage the parking brake, and lower the loader arms.
2. Shut off the engine and remove the key.
3. Release the 2 locking tabs on top of the rear-access cover (Figure 23).

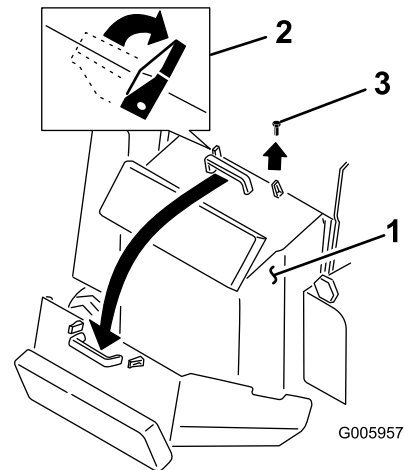

**Figure 23**

1. Rear-access cover
2. Locking tabs
3. Bolt

4. Remove the bolt located next to the right locking tab (Figure 23).
5. Grasping the handle, pull the cover up and back to swing it open (Figure 23).
6. When finished, close the rear-access cover by swinging it up and seating it in place.
7. Secure it with the 2 locking tabs and bolt.

# Lubrication

## Greasing the Machine

**Service Interval:** Before each use or daily (Grease immediately after every washing.)

**Grease Type:** General-purpose grease

1. Park the machine on a level surface, engage the parking brake (if equipped), and lower the loader arms.
2. Shut off the engine and remove the key.
3. Clean the grease fittings with a rag.
4. Connect a grease gun to each fitting (Figure 24 and Figure 25).

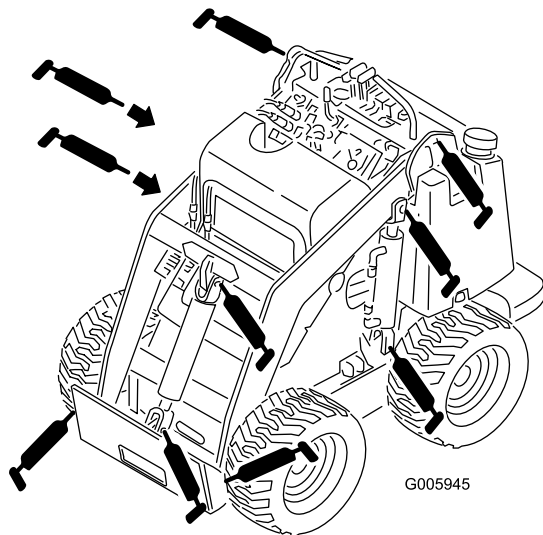

Figure 24

g005945

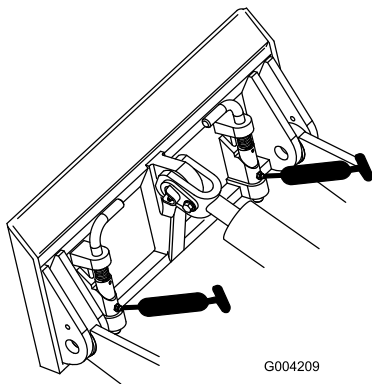

Figure 25

g004209

5. Pump grease into the fittings until grease begins to ooze out of the bearings (approximately 3 pumps).
6. Wipe up any excess grease.

# Engine Maintenance

## Engine Safety

- Shut off the engine before checking the oil or adding oil to the crankcase.
- Do not change the engine governor setting or overspeed the engine.
- Keep your hands, feet, face, clothing, and other body parts away from the muffler and other hot surfaces.

## Servicing the Air Cleaner

**Service Interval:** Every 200 hours—Service the air cleaner. (Service more frequently if conditions are extremely dusty or sandy.)

1. Park the machine on a level surface, engage the parking brake (if equipped), and lower the loader arms.
2. Shut off the engine and remove the key.
3. Release the latches on the air cleaner and pull the air-cleaner cover off the air-filter body (Figure 26).

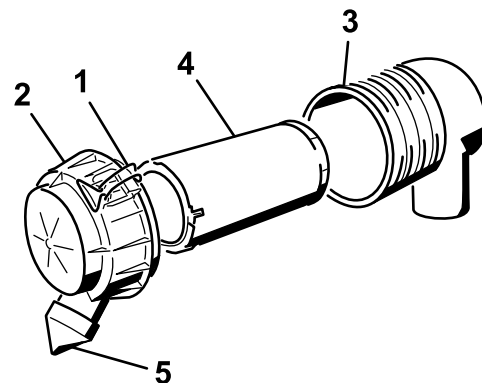

Figure 26

g200767

- |                      |                   |
|----------------------|-------------------|
| 1. Latches           | 4. Primary filter |
| 2. Air-cleaner cover | 5. Dust cap       |
| 3. Air-filter body   |                   |

4. Squeeze the dust cap sides to open it and knock the dust out.
5. Clean the inside of the air-cleaner cover with compressed air that is under 205 kPa (30 psi).

**Important:** Do not use compressed air on the air-cleaner body.

6. Gently slide the filter out of the air-filter body (Figure 26).

**Note:** Avoid knocking the filter into the side of the body.

**Important:** Do not attempt to clean the filter.

- Inspect the new filter for tears, an oily film, or damage to the rubber seal. Look into the filter while shining a bright light on the outside of the filter; holes in the filter appear as bright spots.

If the filter is damaged, do not use it.

- Carefully install the filter (Figure 26).

**Note:** Ensure that the filter is fully seated by pushing on the outer rim of the filter while installing it.

**Important:** Do not press on the soft inside area of the filter.

- Install the air-cleaner cover with the dust cap oriented downward and secure the latches (Figure 26).

## Servicing the Engine Oil

**Service Interval:** Before each use or daily—Check the engine-oil level.

After the first 50 hours—Change the engine oil and filter.

Every 75 hours—Change the engine oil and filter (more frequently when operating conditions are extremely dusty or sandy).

## Engine-Oil Specifications

**Oil Type:** Detergent diesel engine oil (API service CH-4, CI-4, or higher)

**Crankcase Capacity:** with filter, 3.2 L (0.84 US gallons)

**Viscosity:** See the table below.

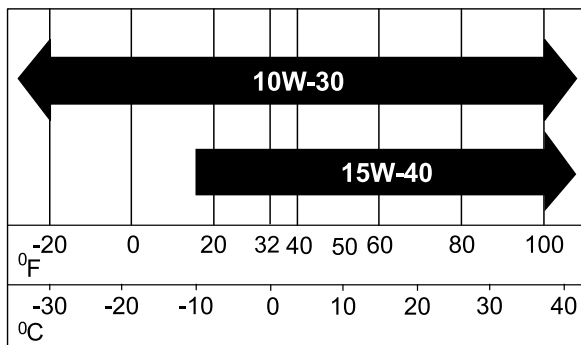

Figure 27

## Checking the Engine-Oil Level

- Park the machine on a level surface, engage the parking brake, and lower the loader arms.
- Shut off the engine, remove the key, and allow the engine to cool.
- Open the rear-access cover.
- Clean the area around the oil dipstick (Figure 28).

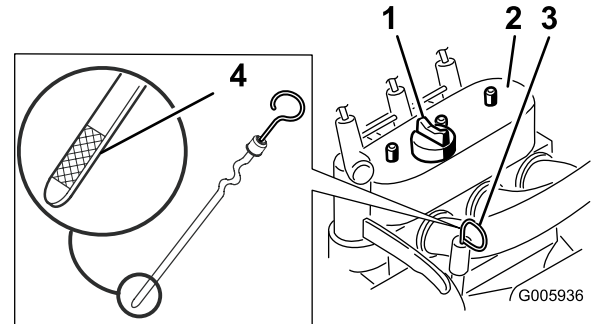

Figure 28

- Fill cap
- Valve cover
- Oil dipstick
- Metal end

- Pull out the dipstick and wipe the metal end clean (Figure 28).
- Slide the dipstick fully into the dipstick tube (Figure 28).
- Pull the dipstick out and look at the metal end.

**Note:** The oil level should be within the crosshatched area on the dipstick.

- If the oil level is low, clean the area around the oil-fill cap and remove the cap (Figure 28).
- Slowly pour oil into the valve cover. Check the oil level again and ensure that the level is at the top of the crosshatched area on the dipstick.

**Note:** Use diesel engine oil, API service CH-4, CI-4, or higher; refer to [Engine-Oil Specifications](#) (page 29).

**Important:** Do not overfill the crankcase with oil because it may damage the engine.

- Replace the fill cap and dipstick.
- Close the rear-access cover.

# Changing the Engine Oil and Filter

1. Start the engine and let it run for 5 minutes.  
**Note:** This warms the oil so that it drains better.
2. Park the machine so that the drain side is slightly lower than the opposite side to ensure that the oil drains completely.
3. Lower the loader arms, engage the parking brake, shut off the engine, and remove the key.
4. Place a pan under the oil-drain tube (Figure 29).

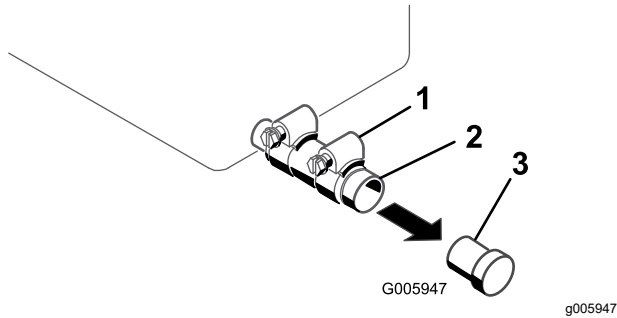

Figure 29

1. Clamp
2. Oil-drain tube
3. Plug

5. Loosen the clamp and remove the plug (Figure 29).
6. When the oil has drained completely, replace the plug and tighten the clamp.

**Note:** Dispose of the used oil at a certified recycling center.

7. Open the rear-access cover.
8. Remove the old filter and wipe the filter adapter (Figure 30) gasket surface.

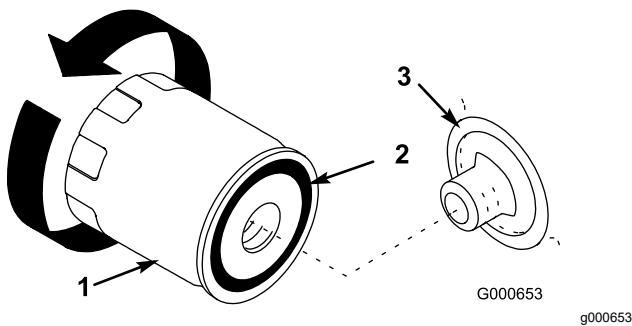

Figure 30

1. Oil filter
2. Gasket
3. Adapter

tighten the filter an additional 1/2 turn (Figure 30).

11. Remove the fill cap (Figure 28) and slowly pour approximately 80% of the specified amount of oil in through the valve cover.
12. Check the oil level.
13. Slowly add additional oil to bring the level to the upper mark on the dipstick.
14. Replace the fill cap.
15. Start the engine and let it run for 15 seconds to allow the filter to fill with oil.
16. Park the machine on a level surface, shut off the engine, and remove the key.
17. Check the engine-oil level. Add oil if needed.
18. Close the rear-access cover.

9. Apply a thin coat of new oil to the rubber gasket on the replacement filter (Figure 30).
10. Install the replacement oil filter to the filter adapter. Turn the oil filter clockwise until the rubber gasket contacts the filter adapter, then

# Fuel System Maintenance

## **⚠ DANGER**

In certain conditions, fuel is extremely flammable and highly explosive. A fire or explosion from fuel can burn you and others and can damage property.

- Drain fuel from the fuel tanks when the engine is cold. Do this outdoors in an open area. Wipe up any fuel that spills.
- Never smoke when draining fuel, and stay away from an open flame or where a spark may ignite the fumes.
- Refer to [Fuel Safety \(page 16\)](#) for a complete list of fuel related precautions.

## Draining Water from the Fuel Filter

**Service Interval:** Before each use or daily

1. Park the machine on a level surface, engage the parking brake, and lower the loader arms.
2. Shut off the engine and remove the key.
3. Open the rear-access cover.
4. Turn the drain valve until the water runs out of the filter ([Figure 31](#)).

**Note:** The fuel filter is located near the bottom of the fuel tank.

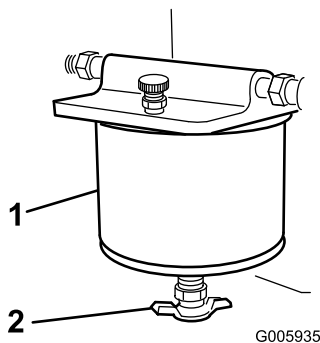

**Figure 31**

1. Fuel filter
2. Drain valve

## Changing the Fuel Filter

**Service Interval:** Yearly

**Important:** Never install a dirty filter.

1. Park the machine on a level surface, engage the parking brake, and lower the loader arms.
2. Shut off the engine and remove the key.
3. Shut off the fuel valve on the bottom of the fuel tank ([Figure 34](#)).
4. Open the rear-access cover.
5. Open the drain valve ([Figure 32](#)) and drain the fuel from the fuel filter into a suitable container and dispose of it properly.

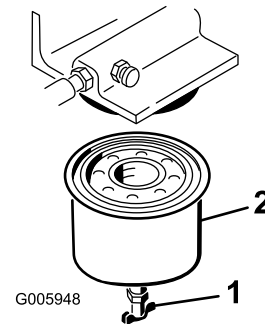

**Figure 32**

1. Drain valve
2. Fuel filter

6. Remove the fuel filter with a filter wrench ([Figure 32](#)).
7. Clean the mounting surface.
8. Lubricate the gasket on the new filter with clean engine oil.
9. Screw on the new filter by hand until the gasket contacts the housing, then tighten it another 1/2 turn.
10. Open the fuel valve on the bottom of the fuel tank ([Figure 34](#)).
11. Bleed the fuel system; refer to [Bleeding the Fuel System \(page 32\)](#).
12. Start the engine and check for leaks.

5. Close the valve.
6. Close the rear-access cover.



# Bleeding the Fuel System

Bleed the air from the fuel system in any of the following situations:

- Initial start-up of a new machine or a machine that has been stored
  - After the engine has ceased running due to lack of fuel
  - After maintenance has been performed on the fuel system components
1. Park the machine on a level surface, engage the parking brake, and lower the loader arms.
  2. Shut off the engine and remove the key.
  3. Open the rear-access cover.
  4. Place a drain pan under the fuel filter to catch fuel spills.
  5. Open the bleed screw on top of the fuel filter to fill the bowl with fuel (Figure 33).

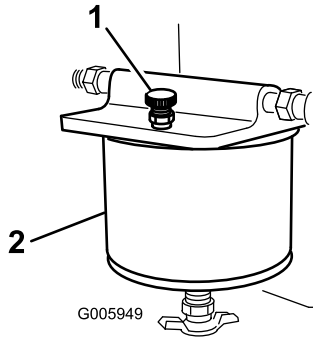

**Figure 33**

1. Fuel filter
2. Bleed screw

6. Close the bleed screw when fuel comes out in a steady stream.
7. On left side of the engine, locate the air vent plug on top of the fuel-injection pump and connect a hose to it, leading to a drain pan.
8. Open the vent plug and crank the engine until fuel comes out a steady stream.
9. Close the vent plug.
10. Close the rear-access cover.

# Draining the Fuel Tank

1. Park the machine on a level surface, engage the parking brake, and lower the loader arms.
2. Shut off the engine and remove the key.
3. Shut off the fuel valve in the hose near the bottom of the fuel tank (Figure 34).

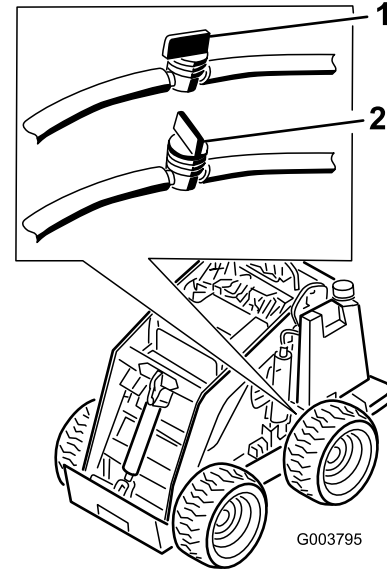

**Figure 34**

1. Fuel valve (open)
2. Fuel valve (closed)

4. Open the rear-access cover.
5. Loosen the hose clamp at the fuel filter and slide it up the fuel line away from the filter.
6. Pull the fuel line off the fuel filter, open the fuel valve, and allow the fuel to drain into a fuel can or drain pan.
7. Close the fuel valve.
8. Install the fuel line onto the fuel filter.
9. Slide the hose clamp close to the fuel filter to secure the fuel line.
10. Close the rear-access cover.
11. Open the fuel valve in the hose near the bottom of the fuel tank as illustrated in Figure 34.

**Note:** Now is the best time to install a new fuel filter because the fuel tank is empty.



# Electrical System Maintenance

## Electrical System Safety

- Disconnect the battery before repairing the machine. Disconnect the negative terminal first and the positive last. Connect the positive terminal first and the negative last.
- Charge the battery in an open, well-ventilated area, away from sparks and flames. Unplug the charger before connecting or disconnecting the battery. Wear protective clothing and use insulated tools.
- Battery acid is poisonous and can cause burns. Avoid contact with skin, eyes, and clothing. Protect your face, eyes, and clothing when working with a battery.
- Battery gases can explode. Keep cigarettes, sparks, and flames away from the battery.

## Servicing the Battery

**Service Interval:** Every 75 hours—Check the battery cable connections.

Every 75 hours—Clean the battery.

Always keep the battery clean and fully charged. Use a paper towel to clean the battery case. If the battery terminals are corroded, clean them with a solution of 4 parts water and 1 part baking soda. Apply a light coating of grease to the battery terminals to reduce corrosion.

**Specifications:** 12 V, 450 A (cold cranking)

## Removing the Battery

1. Park the machine on a level surface, engage the parking brake, and lower the loader arms.
2. Shut off the engine and remove the key.
3. Remove the battery cover ([Figure 35](#))

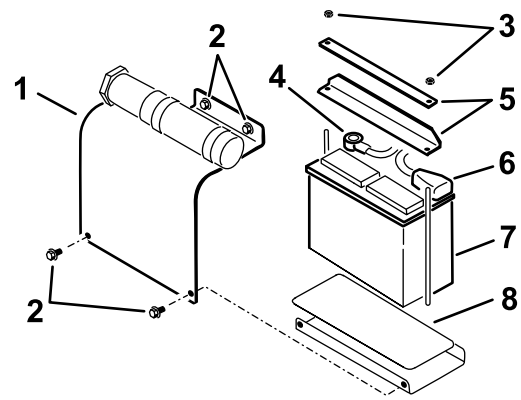

**Figure 35**

g230939

- |                  |                           |
|------------------|---------------------------|
| 1. Battery cover | 5. Nut                    |
| 2. Bolt          | 6. Positive battery cable |
| 3. Battery       | 7. Negative battery cable |
| 4. Bars          | 8. Battery pad            |

4. Remove the nuts and bars securing the battery ([Figure 35](#)).
5. Disconnect the negative (black) cable to the negative (-) battery post ([Figure 35](#)).
6. Disconnect the positive (red) cable to the positive (+) battery post ([Figure 35](#)).
7. Lift the battery off the platform.

## Charging the Battery

**Important:** Always keep the battery fully charged (1.265 specific gravity). This is especially important to prevent battery damage when the temperature is below 0°C (32°F).

1. Remove the battery from the machine; refer to [Removing the Battery \(page 33\)](#).
2. Charge the battery for 10 to 15 minutes at 25 to 30 A or 30 minutes at 4 to 6 A ([Figure 36](#)). Do not overcharge the battery.

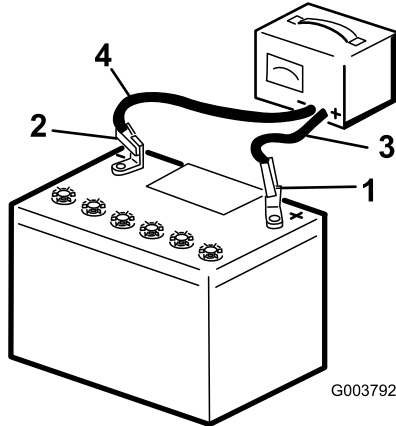

**Figure 36**

- |                          |                           |
|--------------------------|---------------------------|
| 1. Positive battery post | 3. Red (+) charger lead   |
| 2. Negative battery post | 4. Black (-) charger lead |

3. When the battery is fully charged, unplug the charger from the electrical outlet, then disconnect the charger leads from the battery posts ([Figure 36](#)).

## Cleaning the Battery

**Note:** Keep the terminals and the entire battery case clean, to help extend battery life.

1. Park the machine on a level surface, engage the parking brake (if equipped), and lower the loader arms.
2. Shut off the engine and remove the key.
3. Remove the battery from the machine; refer to [Removing the Battery \(page 33\)](#).
4. Wash the entire case with a solution of baking soda and water.
5. Rinse the battery with clear water.
6. Coat the battery posts and cable connectors with Grafo 112X (skin-over) grease (Toro Part No. 505-47) or petroleum jelly to prevent corrosion.
7. Install the battery; refer to [Installing the Battery \(page 34\)](#).

## Installing the Battery

1. Install the battery onto the platform ([Figure 35](#)).
2. Secure the battery in the chassis with the bars and nuts removed previously ([Figure 35](#)).
3. Using the fasteners previously removed, install the positive (red) battery cable to the positive (+) battery terminal ([Figure 35](#)).
4. Slide the red terminal boot onto the positive battery post.
5. Using the fasteners previously removed, install the negative (black) battery cable to the negative (-) battery terminal ([Figure 35](#)).
6. Install the battery cover ([Figure 35](#)).

**Important:** Ensure that the battery cables do not contact any sharp edges or each other.

## Servicing a Replacement Battery

The original battery is maintenance-free and does not require service. For servicing a replacement battery, refer to the battery manufacturer's instructions.

# Drive System Maintenance

## Checking the Tire Pressure

**Service Interval:** Before each use or daily

Maintain the air pressure in the tires as specified. Check the tires when they are cold to get the most accurate reading.

**Pressure:** 103 to 138 kPa (15 to 20 psi)

**Note:** Use a lower tire pressure, 103 kPa (15 psi), when operating in sandy soil conditions to provide better traction in the loose soil.

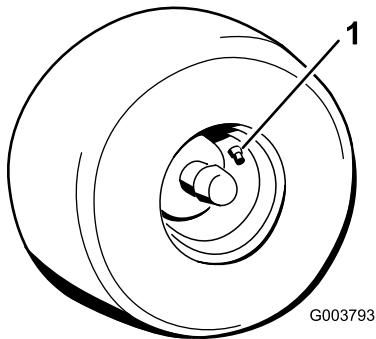

Figure 37

1. Valve stem

## Checking the Wheel-Lug Nuts

**Service Interval:** After the first 8 hours

Every 100 hours

Check and torque the wheel lug nuts to 68 N·m (50 ft-lb).

# Cooling System Maintenance

## Cooling System Safety

- Swallowing engine coolant can cause poisoning; keep out of reach from children and pets.
- Discharge of hot, pressurized coolant or touching a hot radiator and surrounding parts can cause severe burns.
  - Always allow the engine to cool at least 15 minutes before removing the radiator cap.
  - Use a rag when opening the radiator cap, and open the cap slowly to allow steam to escape.

## Cleaning the Radiator Screen

**Service Interval:** Before each use or daily

Remove any buildup of grass, dirt or other debris from the radiator screen with compressed air.

## Checking the Engine-Coolant Level

**Service Interval:** Before each use or daily

The cooling system is filled with a 50/50 solution of water and permanent ethylene glycol antifreeze. Check the level of coolant at the beginning of each day, before starting the engine.

### **⚠ DANGER**

**The rotating shaft and fan can cause personal injury.**

- **Do not operate the machine without the covers in place.**
  - **Keep your fingers, hands, and clothing clear of the rotating fan and drive shaft.**
  - **Park the machine on a level surface, lower the loader arms, engage the parking brake, shut off the engine, and remove the key from the key switch before performing maintenance.**
1. Park the machine on a level surface, lower the loader arms, engage the parking brake, and shut off the engine.
  2. Remove the key from the key switch and allow the engine to cool.

3. Remove the radiator cap and check the coolant level ([Figure 38](#)).

The coolant should be up to the filler neck.

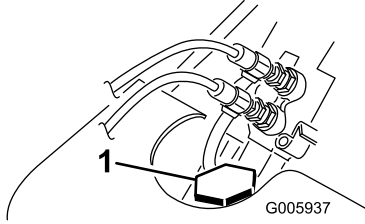

**Figure 38**

g005937

1. Radiator cap
- 

4. If the coolant level is low, add coolant up to the bottom of the filler neck.

**Important:** Do not overfill the radiator.

5. Replace the radiator cap, ensuring that it is tightly sealed.

## Changing the Engine Coolant

**Service Interval:** Yearly

Have an Authorized Service Dealer change the engine coolant yearly.

If you need to add engine coolant, refer to [Checking the Engine-Coolant Level \(page 35\)](#).

## Brake Maintenance

### Testing the Parking Brake

**Service Interval:** Before each use or daily

1. Engage the parking-brake; refer to [Parking-Brake Lever \(page 14\)](#).
2. Start the engine.
3. Slowly attempt to drive the machine forward or rearward.
4. If the machine moves, contact your Authorized Service Dealer for service.

# Hydraulic System Maintenance

## Hydraulic System Safety

- Seek immediate medical attention if fluid is injected into skin. Injected fluid must be surgically removed within a few hours by a doctor.
- Ensure that all hydraulic-fluid hoses and lines are in good condition and all hydraulic connections and fittings are tight before applying pressure to the hydraulic system.
- Keep your body and hands away from pinhole leaks or nozzles that eject high-pressure hydraulic fluid.
- Use cardboard or paper to find hydraulic leaks.
- Safely relieve all pressure in the hydraulic system before performing any work on the hydraulic system.

## Relieving Hydraulic Pressure

To relieve hydraulic pressure while the engine is on, disengage the auxiliary hydraulics and fully lower the loader arms.

To relieve the pressure while the engine is off, move the auxiliary-hydraulics lever between the forward and reverse flow positions to relieve auxiliary hydraulic pressure, move the attachment-tilt lever forward and rearward, and move the loader-arm lever forward to lower the loader arms (Figure 39).

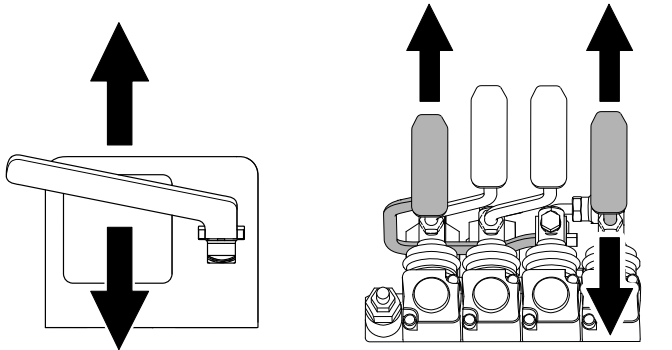

Figure 39

# Hydraulic Fluid Specifications

Every 1,500 hours/Every 2 years (whichever comes first)—Replace all moving hydraulic hoses.

**Hydraulic Tank Capacity:** 56 L (14.8 US gallons)

Use only 1 of the following fluids in the hydraulic system:

- **Toro Premium Transmission/Hydraulic Tractor Fluid** (refer to your Authorized Service Dealer for more information)
- **Toro PX Extended Life Hydraulic Fluid** (refer to your Authorized Service Dealer for more information)
- If either of the above Toro fluids are not available, you may use another Universal Tractor Hydraulic Fluid (UTHF), but they must be only conventional, petroleum-based products. The specifications must fall within the listed range for all the following material properties and the fluid should meet the listed industry standards. Check with your hydraulic fluid supplier to determine if the fluid meets these specifications.

**Note:** Toro will not assume responsibility for damage caused by improper substitutions, so use only products from reputable manufacturers who will stand behind their recommendations.

Material Properties	
Viscosity, ASTM D445	cSt at 40°C: 55 to 62
	cSt at 100°C: 9.1 to 9.8
Viscosity index, ASTM D2270	140 to 152
Pour Point, ASTM D97	-43 to -37°C (-46 to -35°F)
Industry Standards	
API GL-4, AGCO Powerfluid 821 XL, Ford New Holland FNHA-2-C-201.00, Kubota UDT, John Deere J20C, Vickers 35VQ25 and Volvo WB-101/BM	

**Note:** Many hydraulic fluids are almost colorless, making it difficult to spot leaks. A red dye additive for the hydraulic system fluid is available in 20 ml (0.67 fl oz) bottles. One bottle is sufficient for 15 to 22 L (4 to 6 US gallons) of hydraulic fluid. Order Part No. 44-2500 from your Authorized Service Dealer.

# Checking the Hydraulic-Fluid Level

**Service Interval:** Every 25 hours

Check the hydraulic-fluid level before the engine is first started and after every 25 operating hours.

Refer to [Hydraulic Fluid Specifications \(page 37\)](#).

**Important:** Always use the correct hydraulic fluid. Unspecified fluids will damage the hydraulic system.

1. Park the machine on a level surface, remove any attachment, engage the parking brake (if equipped), raise the loader arms, and install the cylinder locks.
2. Shut off the engine, remove the key, and allow the engine to cool.
3. Remove the hood/front access cover.
4. Clean the area around the filler neck of the hydraulic tank ([Figure 40](#)).
5. Remove the filler-neck cap and check the fluid level on the dipstick ([Figure 40](#)).

The fluid level should be between the marks on the dipstick.

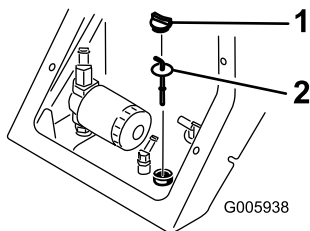

**Figure 40**

1. Filler neck cap
2. Dipstick

6. If the level is low, add enough fluid to raise it to the proper level.
7. Install the filler-neck cap.
8. Install the hood/front access cover.
9. Remove and store the cylinder locks and lower the loader arms.

# Replacing the Hydraulic Filter

**Service Interval:** After the first 8 hours

Every 400 hours

**Important:** Do not substitute an automotive oil filter; otherwise, severe hydraulic system damage may result.

1. Park the machine on a level surface, remove any attachment, engage the parking brake (if equipped), raise the loader arms, and install the cylinder locks.
2. Shut off the engine and remove the key.
3. Remove the hood/front access cover.
4. Place a drain pan under the filter.
5. Remove the old filter ([Figure 41](#)) and wipe the surface of the filter adapter clean.

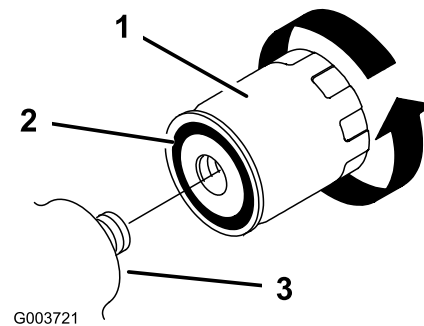

**Figure 41**

1. Hydraulic filter
2. Gasket
3. Filter adapter

6. Apply a thin coat hydraulic fluid to the rubber gasket on the replacement filter ([Figure 41](#)).
7. Install the replacement hydraulic filter onto the filter adapter ([Figure 41](#)). Tighten it clockwise until the rubber gasket contacts the filter adapter, then tighten the filter an additional 1/2 turn.
8. Clean up any spilled fluid.
9. Start the engine and let it run for about 2 minutes to purge air from the system.
10. Shut off the engine and check for leaks.
11. Check the fluid level in the hydraulic tank; refer to [Checking the Hydraulic-Fluid Level \(page 38\)](#). Add fluid to raise the level to mark on dipstick. Do not overfill the tank.
12. Install the hood/front access cover.
13. Remove and store the cylinder locks and lower the loader arms.

# Changing the Hydraulic Fluid

**Service Interval:** Yearly

1. Park the machine on a level surface, remove any attachment, engage the parking brake (if equipped), raise the loader arms, and install the cylinder locks.
2. Shut off the engine and remove the key.
3. Remove the hood/front-access cover.
4. Place a large drain pan under the machine that can hold at least 61 L (16 US gallons).
5. Remove the drain plug from the bottom of the hydraulic tank and allow the fluid to completely drain out.
6. Install the drain plug.
7. Fill the hydraulic tank with hydraulic fluid; refer to [Hydraulic Fluid Specifications \(page 37\)](#).

**Note:** Dispose of used oil at a certified recycling center.

8. Install the hood/front-access cover.
9. Remove and store the cylinder locks and lower the loader arms.

# Cleaning

## Removing Debris

**Service Interval:** Before each use or daily

**Important:** Operating the engine with blocked screens and/or cooling shrouds removed will result in engine damage due to overheating.

1. Park the machine on a level surface, raise the loader arms, and install the cylinder locks.
2. Shut off the engine and remove the key.
3. Remove the front-access cover.
4. Clean any debris from the grill.
5. Open the rear-access cover.
6. Wipe away debris from the air cleaner.
7. Clean any debris buildup on the engine with a brush or blower.

**Important:** Blow the dirt out rather than wash it out. If you use water, keep it away from electrical items and hydraulic valves. Do not use a high-pressure washer. High-pressure washing can damage the electrical system and hydraulic valves or deplete grease.

8. Replace and secure the front and rear-access covers.
9. Remove and store the cylinder locks and lower the loader arms.

# Storage

## Storage Safety

- Shut off the engine, remove the key, wait for all moving parts to stop, and allow the machine to cool before storing it.
- Do not store the machine or fuel near flames.

## Storage

1. Park the machine on a level surface, engage the parking brake, and lower the loader arms.
2. Shut off the engine and remove the key.
3. Remove dirt and grime from the external parts of the entire machine, especially the engine. Clean dirt and chaff from the radiator.

***Important:*** Wash the machine using mild detergent and water. Do not pressure-wash the machine. Avoid excessive use of water, especially near the control panel, engine, hydraulic pumps, and motors.

4. Service the air cleaner; refer to [Servicing the Air Cleaner \(page 28\)](#).
5. Grease the machine; refer to [Greasing the Machine \(page 28\)](#).
6. Drain water from the fuel filter; refer to [Draining Water from the Fuel Filter \(page 31\)](#).
7. Torque the wheel lug nuts to 68 N·m (50 ft-lb).
8. Check the hydraulic fluid level; refer to [Checking the Hydraulic-Fluid Level \(page 38\)](#).
9. Check the tire pressure; refer to [Checking the Tire Pressure \(page 35\)](#).
10. Charge the battery; refer to the [Charging the Battery \(page 34\)](#).
11. Flush the fuel tank with fresh, clean diesel fuel.
12. Check and tighten all fasteners. Repair or replace any worn, damaged, or missing parts.
13. Paint all scratched or bare metal surfaces with paint available from your Authorized Service Dealer.
14. Check antifreeze protection and fill the radiator with a 50/50 solution of water and permanent ethylene glycol antifreeze. Refer to your engine owner's manual or Authorized Service Dealer for details on checking and maintaining the cooling system.
15. Store the machine in a clean, dry garage or storage area. Remove the key from the key switch and keep it in a memorable place.

16. Cover the machine to protect it and keep it clean.

***Important:*** When removing the machine from storage, charge the battery; refer to [Charging the Battery \(page 34\)](#).



# Troubleshooting

Problem	Possible Cause	Corrective Action
The starter does not crank.	<ol style="list-style-type: none"> <li>1. The electrical connections are corroded or loose.</li> <li>2. A fuse is loose or blown.</li> <li>3. The battery is discharged.</li> <li>4. The relay or switch is damaged.</li> <li>5. A starter or starter solenoid is damaged.</li> <li>6. Internal engine components have seized.</li> </ol>	<ol style="list-style-type: none"> <li>1. Check the electrical connections for good contact.</li> <li>2. Connect or replace the fuse.</li> <li>3. Charge the battery or replace it.</li> <li>4. Contact your Authorized Service Dealer.</li> <li>5. Contact your Authorized Service Dealer.</li> <li>6. Contact your Authorized Service Dealer.</li> </ol>
The engine cranks but does not start.	<ol style="list-style-type: none"> <li>1. The starting procedure is incorrect.</li> <li>2. The fuel tank is empty.</li> <li>3. The fuel-shutoff valve is closed.</li> <li>4. Dirt, water, stale fuel, or incorrect fuel is in the fuel system.</li> <li>5. The fuel line is clogged.</li> <li>6. There is air in the fuel.</li> <li>7. The glow plugs are inoperative.</li> <li>8. The cranking speed is slow.</li> <li>9. The air-cleaner filters are dirty.</li> <li>10. The fuel filter is clogged.</li> <li>11. The improper fuel grade for cold weather is in the machine.</li> <li>12. There is low compression.</li> <li>13. The injection nozzles are damaged.</li> <li>14. The injection pump timing is incorrect.</li> <li>15. The injection pump is damaged.</li> <li>16. The ETR solenoid is damaged.</li> </ol>	<ol style="list-style-type: none"> <li>1. Use the correct starting procedure.</li> <li>2. Fill the tank with fresh fuel.</li> <li>3. Open the fuel-shutoff valve.</li> <li>4. Drain and flush the fuel system; add fresh fuel.</li> <li>5. Clean or replace the fuel line.</li> <li>6. Bleed the nozzles and check for air leaks at the fuel hose connections and fittings between the fuel tank and engine.</li> <li>7. Check the fuse, glow plugs, and wiring.</li> <li>8. Check the battery, oil viscosity, and starting motor (contact your Authorized Service Dealer).</li> <li>9. Service the air filters.</li> <li>10. Replace the fuel filter.</li> <li>11. Drain the fuel system and replace the fuel filter. Add fresh fuel of proper grade for ambient temperature conditions. You may need to warm the entire traction unit.</li> <li>12. Contact your Authorized Service Dealer.</li> <li>13. Contact your Authorized Service Dealer.</li> <li>14. Contact your Authorized Service Dealer.</li> <li>15. Contact your Authorized Service Dealer.</li> <li>16. Contact your Authorized Service Dealer.</li> </ol>

Problem	Possible Cause	Corrective Action
The engine starts but does not keep running.	<ol style="list-style-type: none"> <li>1. The fuel-tank vent is restricted.</li> <li>2. Dirt or water is in the fuel system.</li> <li>3. The fuel filter is clogged.</li> <li>4. There is air in the fuel.</li> <li>5. Improper fuel grade for cold weather was used in the machine.</li> <li>6. The spark-arrestor screen is clogged.</li> <li>7. The fuel pump is damaged.</li> </ol>	<ol style="list-style-type: none"> <li>1. Loosen the cap. If the engine runs with the cap loosened, replace the cap.</li> <li>2. Drain and flush the fuel system; add fresh fuel.</li> <li>3. Replace the fuel filter.</li> <li>4. Bleed the nozzles and check for air leaks at fuel hose connections and fittings between the fuel tank and engine.</li> <li>5. Drain the fuel system and replace the fuel filter. Add fresh fuel of proper grade for ambient temperature conditions.</li> <li>6. Clean or replace the spark-arrestor screen.</li> <li>7. Contact your Authorized Service Dealer.</li> </ol>
The engine runs but knocks or misses.	<ol style="list-style-type: none"> <li>1. Dirt, water, stale fuel, or incorrect fuel is in the fuel system.</li> <li>2. The engine is overheating.</li> <li>3. There is air in the fuel.</li> <li>4. The injection nozzles are damaged.</li> <li>5. There is low compression</li> <li>6. The injection-pump timing is incorrect.</li> <li>7. There is excessive carbon buildup.</li> <li>8. There is internal wear or damage.</li> </ol>	<ol style="list-style-type: none"> <li>1. Drain and flush the fuel system; add fresh fuel.</li> <li>2. Refer to "The engine overheats."</li> <li>3. Bleed the nozzles and check for air leaks at the fuel hose connections and fittings between the fuel tank and engine.</li> <li>4. Contact your Authorized Service Dealer.</li> <li>5. Contact your Authorized Service Dealer.</li> <li>6. Contact your Authorized Service Dealer.</li> <li>7. Contact your Authorized Service Dealer.</li> <li>8. Contact your Authorized Service Dealer.</li> </ol>
The engine does not idle.	<ol style="list-style-type: none"> <li>1. The fuel-tank vent is restricted.</li> <li>2. Dirt, water, stale fuel, or incorrect fuel is in the fuel system.</li> <li>3. The air-cleaner filters are dirty.</li> <li>4. The fuel filter is clogged.</li> <li>5. There is air in the fuel.</li> <li>6. The fuel pump is damaged.</li> <li>7. There is low compression</li> </ol>	<ol style="list-style-type: none"> <li>1. Loosen the cap. If the engine runs with the cap loosened, replace the cap.</li> <li>2. Drain and flush the fuel system; add fresh fuel.</li> <li>3. Service the air filters.</li> <li>4. Replace the fuel filter.</li> <li>5. Bleed the nozzles and check for air leaks at fuel hose connections and fittings between the fuel tank and engine.</li> <li>6. Contact your Authorized Service Dealer.</li> <li>7. Contact your Authorized Service Dealer.</li> </ol>

Problem	Possible Cause	Corrective Action
The engine overheats.	<ol style="list-style-type: none"> <li>1. More coolant is needed.</li> <li>2. There is restricted air flow to the radiator.</li> <li>3. The crankcase-oil level is incorrect.</li> <li>4. The engine load is excessive.</li> <li>5. Incorrect fuel is in the fuel system.</li> <li>6. The thermostat is damaged.</li> <li>7. The fan belt is loose or broken.</li> <li>8. Injection timing is incorrect.</li> <li>9. The coolant pump is damaged.</li> <li>10. The engine rpm is too low.</li> </ol>	<ol style="list-style-type: none"> <li>1. Check and add coolant.</li> <li>2. Inspect and clean the radiator screen with every use.</li> <li>3. Fill or drain to the Full mark.</li> <li>4. Reduce the load; use a lower ground speed.</li> <li>5. Drain and flush the fuel system; add fresh fuel.</li> <li>6. Contact your Authorized Service Dealer.</li> <li>7. Contact your Authorized Service Dealer.</li> <li>8. Contact your Authorized Service Dealer.</li> <li>9. Contact your Authorized Service Dealer.</li> <li>10. Check the high idle speed.</li> </ol>
The engine loses power.	<ol style="list-style-type: none"> <li>1. The engine load is excessive.</li> <li>2. The crankcase-oil level is incorrect.</li> <li>3. The air-cleaner filters are dirty.</li> <li>4. Dirt, water, stale fuel, or incorrect fuel is in the fuel system.</li> <li>5. The engine is overheating.</li> <li>6. The spark-arrestor screen is clogged.</li> <li>7. There is air in the fuel.</li> <li>8. There is low compression</li> <li>9. The fuel-tank vent is restricted.</li> <li>10. The injection-pump timing is incorrect.</li> <li>11. The injection pump is damaged.</li> <li>12. The engine high idle speed is too low.</li> </ol>	<ol style="list-style-type: none"> <li>1. Reduce the load; use a lower ground speed.</li> <li>2. Fill or drain to the Full mark.</li> <li>3. Service the air filters.</li> <li>4. Drain and flush the fuel system; add fresh fuel.</li> <li>5. Refer to "The engine overheats."</li> <li>6. Clean or replace the spark-arrestor screen.</li> <li>7. Bleed the nozzles and check for air leaks at fuel hose connections and fittings between the fuel tank and engine.</li> <li>8. Contact your Authorized Service Dealer.</li> <li>9. Contact your Authorized Service Dealer.</li> <li>10. Contact your Authorized Service Dealer.</li> <li>11. Contact your Authorized Service Dealer.</li> <li>12. Contact your Authorized Service Dealer.</li> </ol>
Exhaust produces excessive black smoke.	<ol style="list-style-type: none"> <li>1. The engine load is excessive.</li> <li>2. The air-cleaner filters are dirty.</li> <li>3. Incorrect fuel is in the fuel system.</li> <li>4. The injection-pump timing is incorrect.</li> <li>5. The injection pump is damaged.</li> <li>6. The injection nozzles are damaged.</li> </ol>	<ol style="list-style-type: none"> <li>1. Reduce the load; use a lower ground speed.</li> <li>2. Service the air filters.</li> <li>3. Drain and flush the fuel system; add fresh fuel.</li> <li>4. Contact your Authorized Service Dealer.</li> <li>5. Contact your Authorized Service Dealer.</li> <li>6. Contact your Authorized Service Dealer.</li> </ol>

Problem	Possible Cause	Corrective Action
Exhaust produces excessive white smoke.	<ol style="list-style-type: none"> <li>1. The key was turned to the START position before the glow-plug light turned off.</li> <li>2. The engine temperature is low.</li> <li>3. The glow plugs are inoperative.</li> <li>4. The injection-pump timing is incorrect.</li> <li>5. The injection nozzles are damaged.</li> <li>6. There is low compression.</li> </ol>	<ol style="list-style-type: none"> <li>1. Turn the key to the RUN position and allow the glow-plug light to turn off before starting the engine.</li> <li>2. Check the thermostat.</li> <li>3. Check the fuse, glow plugs and wiring.</li> <li>4. Contact your Authorized Service Dealer.</li> <li>5. Contact your Authorized Service Dealer.</li> <li>6. Contact your Authorized Service Dealer.</li> </ol>
The machine does not drive.	<ol style="list-style-type: none"> <li>1. The parking brake is engaged.</li> <li>2. The hydraulic-fluid level is low.</li> <li>3. The hydraulic system is damaged.</li> <li>4. The tow valves are open.</li> <li>5. The flow-divider valve lever is in 9 o'clock position.</li> <li>6. A traction pump drive coupler is loose or broken.</li> <li>7. Pump and/or wheel motor is damaged.</li> <li>8. The control valve is damaged.</li> <li>9. The relief valve is damaged.</li> </ol>	<ol style="list-style-type: none"> <li>1. Disengage the parking brake.</li> <li>2. Add hydraulic fluid to the reservoir.</li> <li>3. Contact your Authorized Service Dealer.</li> <li>4. Close the tow valves.</li> <li>5. Move the lever to the 12 o'clock to 10 o'clock position.</li> <li>6. Contact your Authorized Service Dealer.</li> <li>7. Contact your Authorized Service Dealer.</li> <li>8. Contact your Authorized Service Dealer.</li> <li>9. Contact your Authorized Service Dealer.</li> </ol>

# Schematics

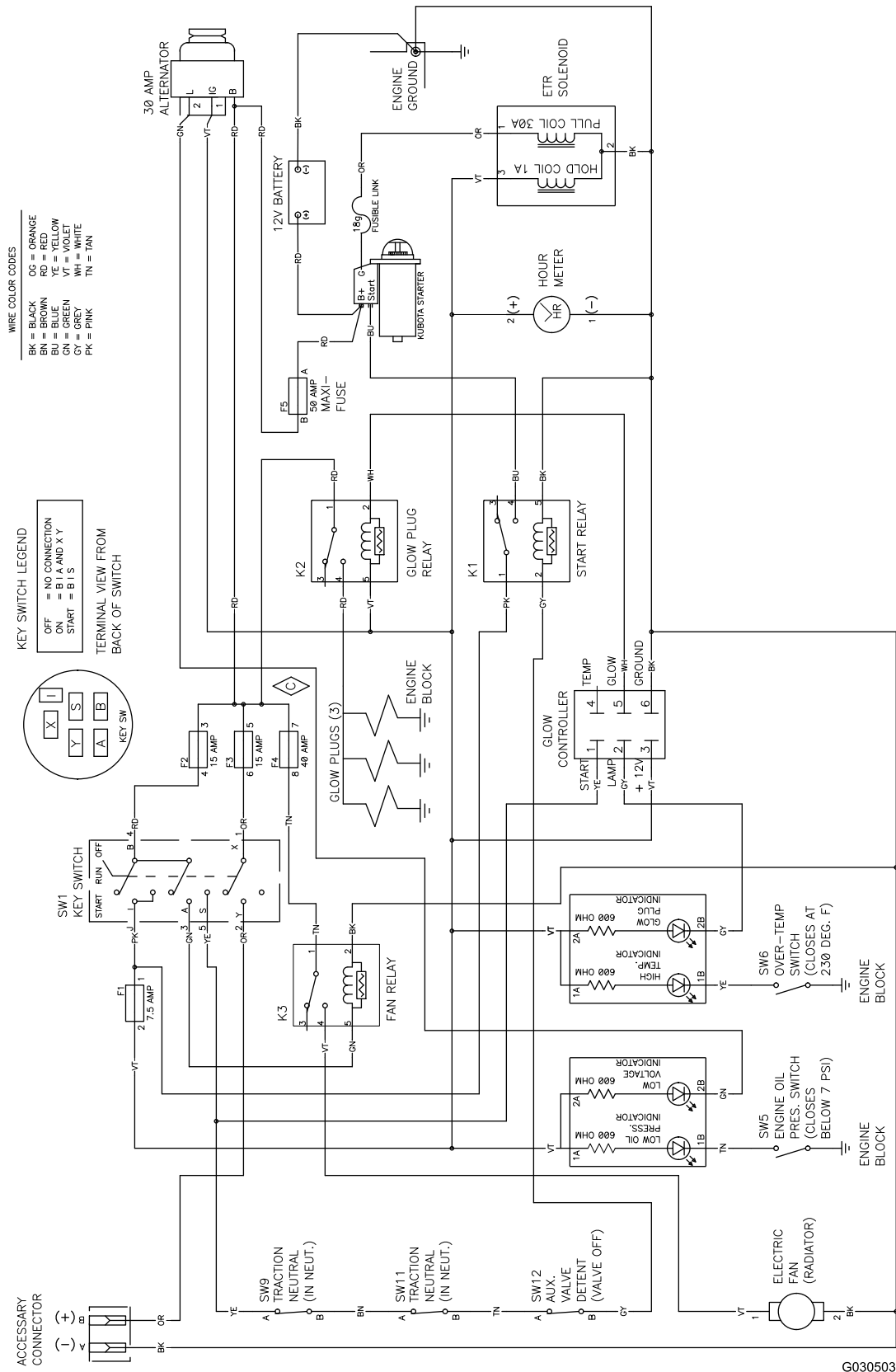

G030503

g030503

Electrical Schematic (Rev. C)

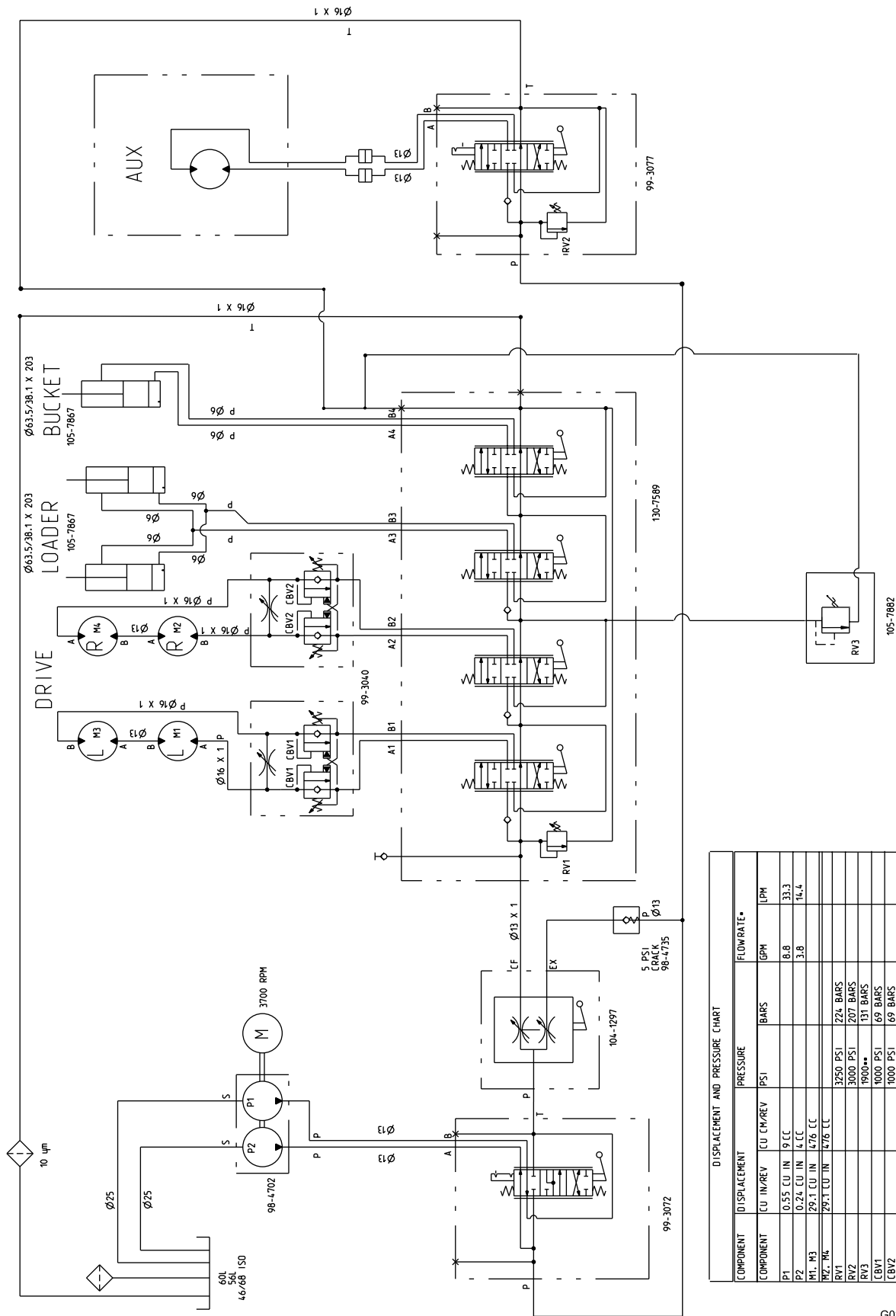

DISPLACEMENT AND PRESSURE CHART

COMPONENT	DISPLACEMENT		PRESSURE		FLOWRATE*	
	CU IN/REV	CU CM/REV	PSI	BAR	GPM	LPM
P1	0.55 CU IN	9 CC	8.8	33.3		
P2	0.24 CU IN	4 CC	3.8	14.4		
M1, M3	29.1 CU IN	476 CC				
M2, M4	29.1 CU IN	476 CC				
RV1			3250 PSI	224 BAR		
RV2			3000 PSI	207 BAR		
RV3			1900**	131 BAR		
CBV1			1000 PSI	69 BAR		
CBV2			1000 PSI	69 BAR		

\* FLOWRATE CALCULATED AT 3700 RPM AND 98% EFFICIENCY.  
 \*\* CRACKING PRESSURE. FULL FLOW - 8 GPM. RELIEF PRESSURE APPROX. 2100 PSI.

Hydraulic Schematic (Rev. B)

G029270

g029270

## **European Privacy Notice**

### **The Information Toro Collects**

Toro Warranty Company (Toro) respects your privacy. In order to process your warranty claim and contact you in the event of a product recall, we ask you to share certain personal information with us, either directly or through your local Toro company or dealer.

The Toro warranty system is hosted on servers located within the United States where privacy law may not provide the same protection as applies in your country.

**BY SHARING YOUR PERSONAL INFORMATION WITH US, YOU ARE CONSENTING TO THE PROCESSING OF YOUR PERSONAL INFORMATION AS DESCRIBED IN THIS PRIVACY NOTICE.**

### **The Way Toro Uses Information**

Toro may use your personal information to process warranty claims, to contact you in the event of a product recall and for any other purpose which we tell you about. Toro may share your information with Toro's affiliates, dealers or other business partners in connection with any of these activities. We will not sell your personal information to any other company. We reserve the right to disclose personal information in order to comply with applicable laws and with requests by the appropriate authorities, to operate our systems properly or for our own protection or that of other users.

### **Retention of your Personal Information**

We will keep your personal information as long as we need it for the purposes for which it was originally collected or for other legitimate purposes (such as regulatory compliance), or as required by applicable law.

### **Toro's Commitment to Security of Your Personal Information**

We take reasonable precautions in order to protect the security of your personal information. We also take steps to maintain the accuracy and current status of personal information.

### **Access and Correction of your Personal Information**

If you would like to review or correct your personal information, please contact us by email at [legal@toro.com](mailto:legal@toro.com).

## **Australian Consumer Law**

Australian customers will find details relating to the Australian Consumer Law either inside the box or at your local Toro Dealer.

# California Proposition 65 Warning Information

## What is this warning?

You may see a product for sale that has a warning label like the following:



**WARNING: Cancer and Reproductive Harm—[www.p65Warnings.ca.gov](http://www.p65Warnings.ca.gov).**

## What is Prop 65?

Prop 65 applies to any company operating in California, selling products in California, or manufacturing products that may be sold in or brought into California. It mandates that the Governor of California maintain and publish a list of chemicals known to cause cancer, birth defects, and/or other reproductive harm. The list, which is updated annually, includes hundreds of chemicals found in many everyday items. The purpose of Prop 65 is to inform the public about exposure to these chemicals.

Prop 65 does not ban the sale of products containing these chemicals but instead requires warnings on any product, product packaging, or literature with the product. Moreover, a Prop 65 warning does not mean that a product is in violation of any product safety standards or requirements. In fact, the California government has clarified that a Prop 65 warning "is not the same as a regulatory decision that a product is 'safe' or 'unsafe.'" Many of these chemicals have been used in everyday products for years without documented harm. For more information, go to <https://oag.ca.gov/prop65/faqs-view-all>.

A Prop 65 warning means that a company has either (1) evaluated the exposure and has concluded that it exceeds the "no significant risk level"; or (2) has chosen to provide a warning based on its understanding about the presence of a listed chemical without attempting to evaluate the exposure.

## Does this law apply everywhere?

Prop 65 warnings are required under California law only. These warnings are seen throughout California in a wide range of settings, including but not limited to restaurants, grocery stores, hotels, schools, and hospitals, and on a wide variety of products. Additionally, some online and mail order retailers provide Prop 65 warnings on their websites or in catalogs.

## How do the California warnings compare to federal limits?

Prop 65 standards are often more stringent than federal and international standards. There are various substances that require a Prop 65 warning at levels that are far lower than federal action limits. For example, the Prop 65 standard for warnings for lead is 0.5 µg/day, which is well below the federal and international standards.

## Why don't all similar products carry the warning?

- Products sold in California require Prop 65 labelling while similar products sold elsewhere do not.
- A company involved in a Prop 65 lawsuit reaching a settlement may be required to use Prop 65 warnings for its products, but other companies making similar products may have no such requirement.
- The enforcement of Prop 65 is inconsistent.
- Companies may elect not to provide warnings because they conclude that they are not required to do so under Prop 65; a lack of warnings for a product does not mean that the product is free of listed chemicals at similar levels.

## Why does Toro include this warning?

Toro has chosen to provide consumers with as much information as possible so that they can make informed decisions about the products they buy and use. Toro provides warnings in certain cases based on its knowledge of the presence of one or more listed chemicals without evaluating the level of exposure, as not all the listed chemicals provide exposure limit requirements. While the exposure from Toro products may be negligible or well within the "no significant risk" range, out of an abundance of caution, Toro has elected to provide the Prop 65 warnings. Moreover, if Toro does not provide these warnings, it could be sued by the State of California or by private parties seeking to enforce Prop 65 and subject to substantial penalties.