



**Count on it.**

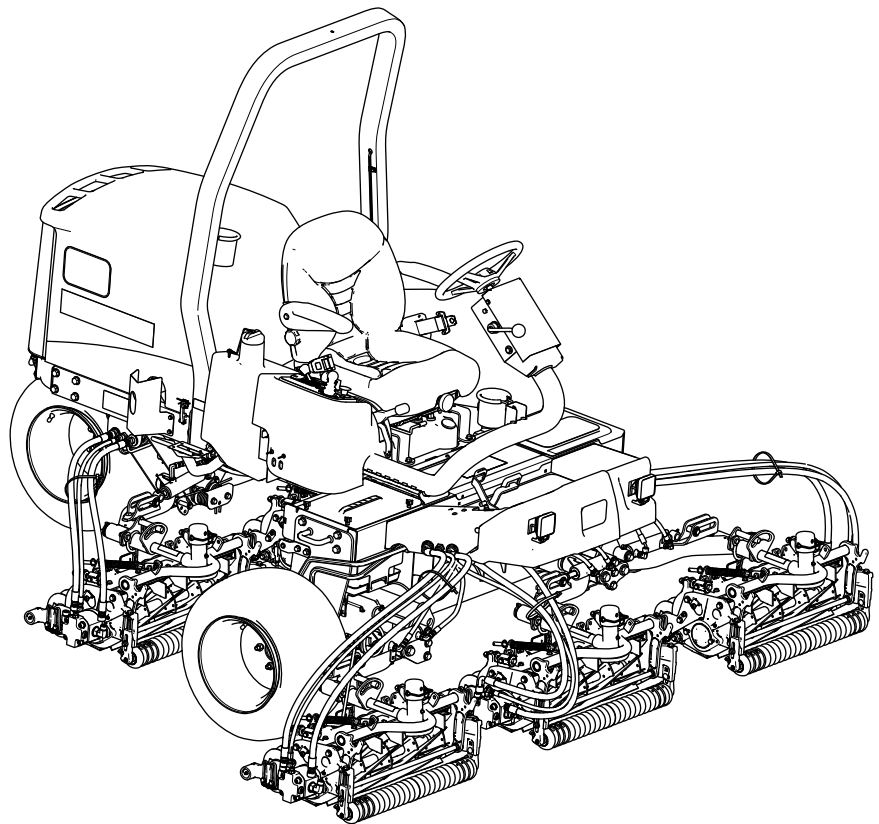
**Operator's Manual**

# Reelmaster® 3555, 3575, and 3550 Traction Unit

Model No. 03820—Serial No. 403446001 and Up

Model No. 03821—Serial No. 403446001 and Up

Model No. 03910—Serial No. 403446001 and Up



This product complies with all relevant European directives; for details, please see the separate product specific Declaration of Conformity (DOC) sheet.

It is a violation of California Public Resource Code Section 4442 or 4443 to use or operate the engine on any forest-covered, brush-covered, or grass-covered land unless the engine is equipped with a spark arrester, as defined in Section 4442, maintained in effective working order or the engine is constructed, equipped, and maintained for the prevention of fire.

The enclosed engine owner's manual is supplied for information regarding the US Environmental Protection Agency (EPA) and the California Emission Control Regulation of emission systems, maintenance, and warranty. Replacements may be ordered through the engine manufacturer.

**⚠ WARNING**

**CALIFORNIA**  
**Proposition 65 Warning**

**Diesel engine exhaust and some of its constituents are known to the State of California to cause cancer, birth defects, and other reproductive harm.**

**Battery posts, terminals, and related accessories contain lead and lead compounds, chemicals known to the State of California to cause cancer and reproductive harm. Wash hands after handling.**

**Use of this product may cause exposure to chemicals known to the State of California to cause cancer, birth defects, or other reproductive harm.**

# Introduction

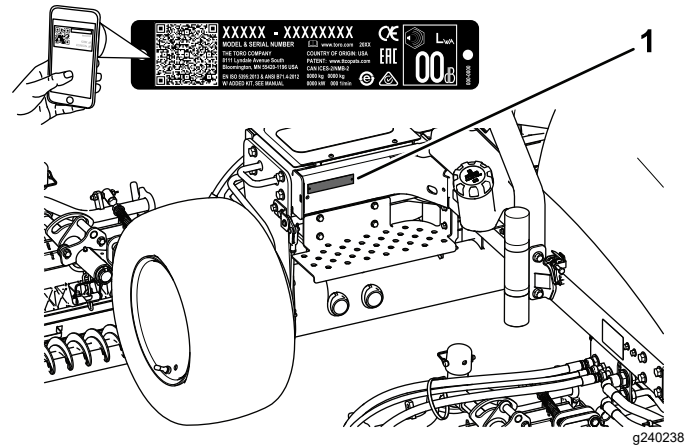
This machine is a ride-on, reel-blade lawn mower intended to be used by professional, hired operators in commercial applications. It is primarily designed for cutting grass on well-maintained turf. Using this product for purposes other than its intended use could prove dangerous to you and bystanders.

Read this information carefully to learn how to operate and maintain your product properly and to avoid injury and product damage. You are responsible for operating the product properly and safely.

Visit [www.Toro.com](http://www.Toro.com) for more information, including safety tips, training materials, accessory information, help finding a dealer, or to register your product.

Whenever you need service, genuine Toro parts, or additional information, contact an Authorized Service Dealer or Toro Customer Service and have the model and serial numbers of your product ready. **Figure 1** identifies the location of the model and serial numbers on the product. Write the numbers in the space provided.

**Important:** With your mobile device, you can scan the QR code on the serial number decal (if equipped) to access warranty, parts, and other product information.



**Figure 1**

1. Model and serial number location

Model No. \_\_\_\_\_

Serial No. \_\_\_\_\_

This manual identifies potential hazards and has safety messages identified by the safety-alert symbol (**Figure 2**), which signals a hazard that may cause serious injury or death if you do not follow the recommended precautions.



**Figure 2**

Safety-alert symbol

This manual uses 2 words to highlight information. **Important** calls attention to special mechanical information and **Note** emphasizes general information worthy of special attention.

# Contents

Safety .....	4
General Safety .....	4
Engine-Emission Certification.....	4
Safety and Instructional Decals .....	5
Setup .....	13
1 Installing the Cutting Units.....	14
2 Adjusting the Turf Compensation	
Spring .....	17
3 Installing the CE Decals .....	17
4 Installing the Hood Latch (CE Only).....	17
5 Reducing the Tire Pressure.....	18
6 Using the Cutting-Unit Kickstand.....	18
Product Overview .....	20
Controls .....	20
Specifications .....	23
Attachments/Accessories .....	23
Before Operation .....	23
Before Operation Safety .....	23
Performing Daily Maintenance.....	24
Checking the Parking Brake .....	24
Filling the Fuel Tank.....	24
Adjusting the Seat .....	25
During Operation .....	26
During Operation Safety .....	26
Starting the Engine .....	27
Shutting Off the Engine.....	27
Setting the Reel Speed.....	27
Adjusting the Lift-Arm Counterbalance .....	29
Bleeding the Fuel System.....	29
Understanding the Diagnostic Light.....	30
Understanding the Diagnostic ACE	
Display.....	30
Checking the Interlock Switches .....	30
Operating Tips .....	32
After Operation .....	33
After Operation Safety .....	33
Pushing or Towing the Machine .....	33
Hauling the Machine.....	34
Identifying the Tie-Down Points .....	34
Maintenance .....	35
Maintenance Safety.....	35
Recommended Maintenance Schedule(s) .....	35
Daily Maintenance Checklist.....	37
Pre-Maintenance Procedures .....	38
Removing the Hood.....	38
Removing the Battery Cover .....	38
Lubrication .....	39
Greasing the Bearings and Bushings.....	39
Engine Maintenance .....	40
Engine Safety.....	40
Checking the Engine-Oil Level.....	40
Servicing the Air Cleaner .....	41
Changing the Engine Oil and Filter.....	42
Fuel System Maintenance .....	42
Servicing the Fuel Tank.....	42

Inspecting the Fuel Lines and	
Connections.....	42
Draining the Water Separator .....	43
Changing the Fuel Filter Canister.....	43
Bleeding Air from the Injectors .....	43
Electrical System Maintenance .....	44
Electrical System Safety .....	44
Servicing the Battery.....	44
Checking the Fuses .....	44
Drive System Maintenance .....	45
Checking the Tire Pressure.....	45
Torquing the Wheel Nuts.....	45
Adjusting the Traction Drive for Neutral .....	45
Cooling System Maintenance .....	46
Cooling System Safety .....	46
Checking the Cooling System.....	46
Cleaning the Engine Cooling System .....	47
Brake Maintenance .....	47
Adjusting the Parking Brake.....	47
Servicing the Parking Brakes.....	47
Belt Maintenance .....	52
Servicing the Engine Belts .....	52
Controls System Maintenance .....	53
Adjusting the Throttle.....	53
Hydraulic System Maintenance .....	53
Hydraulic System Safety.....	53
Checking the Hydraulic Lines and	
Hoses.....	53
Checking the Hydraulic Fluid .....	53
Hydraulic Fluid Specifications.....	54
Hydraulic Fluid Capacity .....	54
Changing the Hydraulic Fluid.....	54
Changing the Hydraulic Filter.....	55
Cutting Unit System Maintenance .....	56
Blade Safety .....	56
Checking the Reel-to-Bedknife Contact .....	56
Using the Optional Gauge Bar .....	57
Backlapping the Cutting Units.....	57
Cleaning .....	58
Washing the Machine .....	58
Storage .....	59
Storage Safety.....	59
Preparing the Traction Unit .....	59
Preparing the Engine.....	59


# Safety

This machine has been designed in accordance with EN ISO 5395 (when you complete the setup procedures) and ANSI B71.4-2017.

## General Safety

This product is capable of amputating hands and feet and of throwing objects.

- Read and understand the contents of this *Operator's Manual* before starting the engine.
- Use your full attention while operating the machine. Do not engage in any activity that causes distractions; otherwise, injury or property damage may occur.
- Do not put your hands or feet near moving components of the machine.
- Do not operate the machine without all guards and other safety protective devices in place and functioning properly on the machine.
- Keep bystanders and children out of the operating area. Never allow children to operate the machine.
- Shut off the engine, remove the key, and wait for all movement to stop before you leave the operator's position. Allow the machine to cool before adjusting, servicing, cleaning, or storing it.

Improperly using or maintaining this machine can result in injury. To reduce the potential for injury, comply with these safety instructions and always pay attention to the safety-alert symbol , which means Caution, Warning, or Danger—personal safety instruction. Failure to comply with these instructions may result in personal injury or death.

## Engine-Emission Certification

The engine in this machine is EPA Tier 4 Final and EU Stage V emissions compliant.

# Safety and Instructional Decals

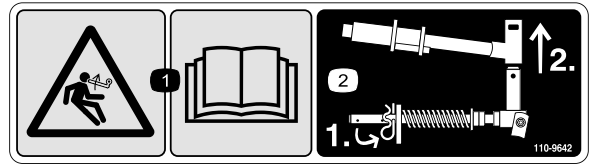


Safety decals and instructions are easily visible to the operator and are located near any area of potential danger. Replace any decal that is damaged or missing.



133-8062

decal133-8062



110-9642

decal110-9642

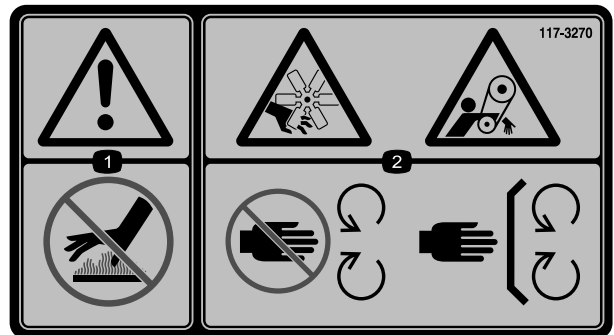
1. Stored energy hazard—read the *Operator's Manual*.
2. Move the cotter pin to the hole closest to the rod bracket and then remove the lift arm and pivot yoke.



93-7276

decal93-7276

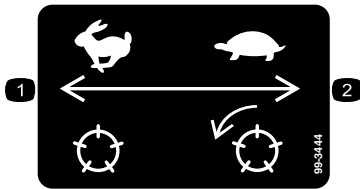
1. Explosion hazard—wear eye protection.
2. Caustic liquid/chemical burn hazard—to perform first aid, flush with water.
3. Fire hazard—no fire, open flames, or smoking.
4. Poison hazard—keep children away from the battery.



117-3270

decal117-3270

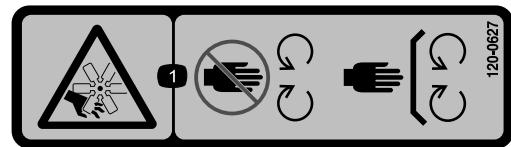
1. Warning—do not touch the hot surface.
2. Cutting/dismemberment hazard, hand; entanglement hazard, belt—stay away from moving parts, keep all guards and shields in place.



99-3444

decal99-3444

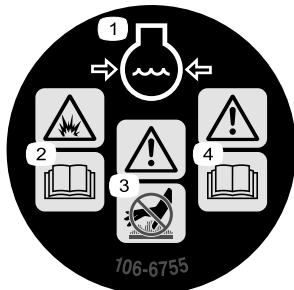
1. Transport speed—fast
2. Mowing speed—slow



120-0627

decal120-0627

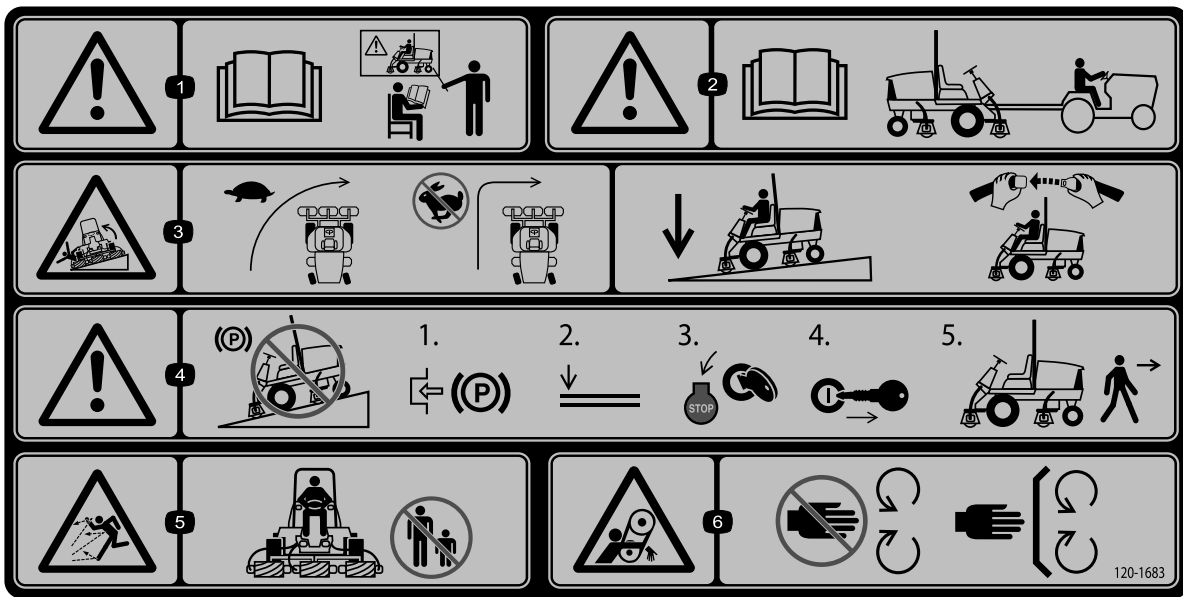
1. Cutting/dismemberment hazard, fan—stay away from moving parts, keep all guards and shields in place.



106-6755

decal106-6755

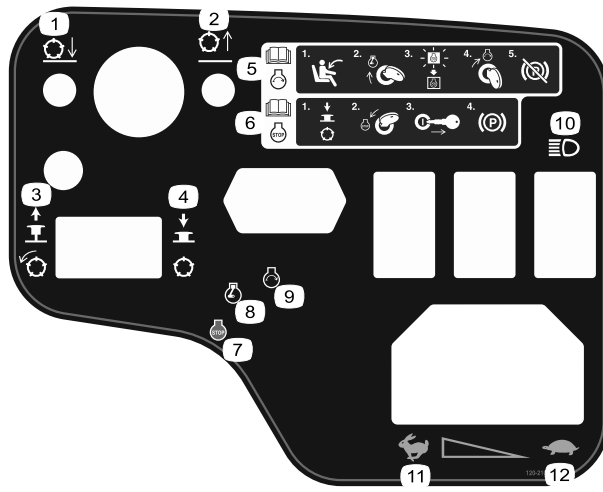
1. Engine coolant under pressure.
2. Explosion hazard—read the *Operator's Manual*.
3. Warning—do not touch the hot surface.
4. Warning—read the *Operator's Manual*.



decal120-1683

### 120-1683

1. Warning—read the *Operator's Manual*; all operators should be trained before operating the machine.
2. Warning—read the *Operator's Manual* before towing the machine.
3. Tipping hazard—drive slowly when turning; do not turn sharply while traveling fast; lower the cutting units when driving down slopes; use a rollover protection system and wear the seatbelt.
4. Warning—do not park the machine on slopes; engage the parking brake, lower the cutting units, shut off the engine, and remove the key before leaving the machine.
5. Thrown object hazard—keep bystanders away.
6. Entanglement hazard, belt—stay away from moving parts; keep all guards and shields in place.



**120-2105**

decal120-2105

1. Lower the cutting units.
2. Raise the cutting units.
3. Pull up to engage the cutting units.
4. Push down to disengage the cutting units.
5. Read the *Operator's Manual* for information on starting the engine—sit in the operator's position, turn the key to the engine preheat position, wait until the engine preheat light turns off, turn the key to the engine start position, and disengage the parking brake.
6. Read the *Operator's Manual* for information on stopping the engine—disengage the cutting units, turn the key to the engine stop position, remove the key from the ignition, and engage the parking brake.
7. Engine—Shut off
8. Engine—Preheat
9. Engine—Start
10. Lights
11. Fast
12. Slow

**HOC**

mm / inches

2	2	2	3	3	3	3	3	3	3
2	2	2	3	3	3	3	3	3	3
2	2	3	3	3	3	3	3	3	3
2	2	3	3	3	3	3	3	3	3
2	2	3	3	3	3	3	3	3	4
2	3	3	3	3	3	3	4	4	4
2	3	3	3	3	3	4	4	4	4
2	3	3	3	3	3	4	4	4	4
3	3	3	3	3	4	4	4	4	4
3	3	3	3	3	4	4	4	4	4
3	3	3	3	4	4	4	4	4	5
3	3	3	4	4	4	4	4	5	5
3	3	4	4	4	4	5	5	6	6
3	4	4	4	4	5	5	6	6	7
4	4	4	5	5	6	6	7	8	8
4	4	5	6	6	7	7	8	9	9
4	5	6	7	7	8	8	9		
5	6	7	8	8	9	9			
6	7	8	9	9					
7	8	9							

4.8 5.6 6.4 7.2 8.1 8.9 9.7 10.5 11.3 km  
3.0 3.5 4.0 4.5 5.0 5.5 6.0 6.5 7.0 mph

**5" (127mm)  
REEL SPEED  
CHART**

1

2

**HOC**

mm / inches

2	3	3	3	3	3	4	4	4	4
3	3	3	3	3	4	4	4	4	4
3	3	3	3	4	4	4	4	5	5
3	3	3	4	4	4	5	6	6	6
3	3	4	4	4	4	5	6	7	7
3	4	4	4	4	5	6	7	7	7
4	4	5	5	6	7	8	8	8	8
4	5	5	6	7	8	9	9	9	9
5	5	6	7	8	9				

4.8 5.6 6.4 7.2 8.1 8.9 9.7 10.5 11.3 km  
3.0 3.5 4.0 4.5 5.0 5.5 6.0 6.5 7.0 mph

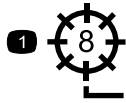
121-7884

**121-7884**

decal121-7884

1. 8-blade reel adjustment
2. 11-blade reel adjustment
3. Read the *Operator's Manual* for information on adjusting the reel.

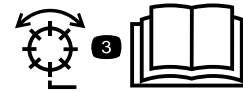
HOC



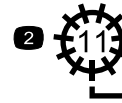
mm / inches	3	3	3	3	3	3	4	4	4
38.1 / 1.500	3	3	3	3	3	3	4	4	4
36.5 / 1.438	3	3	3	3	3	3	4	4	4
34.9 / 1.375	3	3	3	3	3	4	4	4	4
33.3 / 1.313	3	3	3	3	3	4	4	4	4
31.8 / 1.250	3	3	3	3	4	4	4	4	5
30.2 / 1.188	3	3	3	3	4	4	4	4	5
28.6 / 1.125	3	3	3	4	4	4	4	5	5
27.0 / 1.063	3	3	3	4	4	4	4	5	5
25.4 / 1.000	3	3	3	4	4	4	5	5	5
23.8 / 0.938	3	3	4	4	4	4	5	5	5
22.2 / 0.875	3	3	4	4	4	5	5	5	6
20.6 / 0.813	3	4	4	4	5	5	5	6	6
19.5 / 0.750	3	4	4	4	5	5	6	6	7
17.5 / 0.688	4	4	4	5	5	6	6	7	9
15.9 / 0.625	4	4	5	5	6	6	7	9	9
14.3 / 0.563	4	5	5	6	6	7	9		
12.7 / 0.500	4	5	6	7	7	9			
11.1 / 0.438	5	6	7	9	9				
9.5 / 0.375	6	7	9						
7.9 / 0.313	7	9							
6.3 / 0.25									
	4.8	5.6	6.4	7.2	8.1	8.9	9.7	10.5	11.3
	3.0	3.5	4.0	4.5	5.0	5.5	6.0	6.5	7.0



7" (178mm)  
REEL SPEED  
CHART



HOC



mm / inches	3	3	3	4	4	4	4	5	5
19.5 / 0.750	3	3	4	4	4	4	5	5	6
17.5 / 0.688	3	4	4	4	4	5	5	6	6
15.9 / 0.625	3	4	4	4	5	5	6	6	7
14.3 / 0.563	4	4	4	5	5	6	7	7	9
12.7 / 0.500	4	4	5	6	6	7	9	9	9
11.1 / 0.438	4	5	6	7	7	9	9		
9.5 / 0.375	4	5	6	7	7	9	9		
7.9 / 0.313	5	6	7	9	9				
6.4 / 0.250	7	9	9						
	4.8	5.6	6.4	7.2	8.1	8.9	9.7	10.5	11.3
	3.0	3.5	4.0	4.5	5.0	5.5	6.0	6.5	7.0

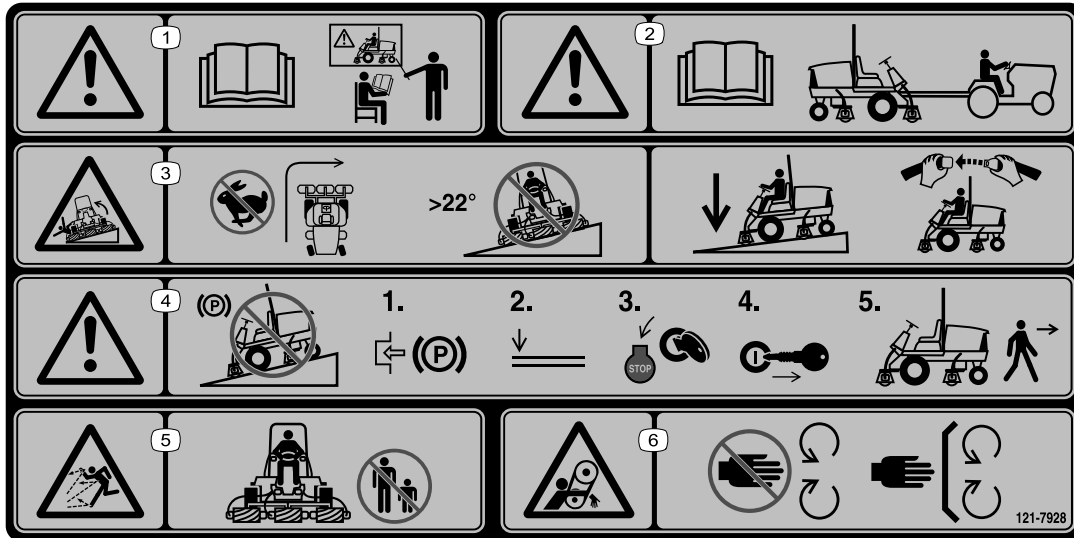


133-4901

decal133-4901

- 8-blade reel adjustment
- 11-blade reel adjustment
- Read the *Operator's Manual* for information on adjusting the reel.



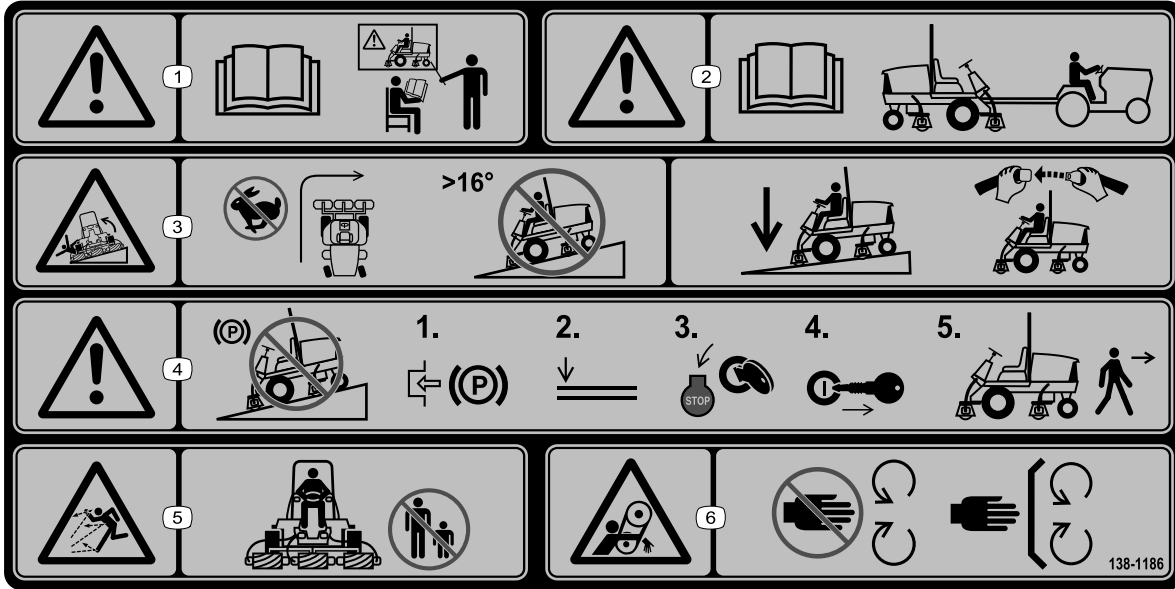


121-7928

decal121-7928

**Note:** This machine complies with the industry standard stability test in the static lateral and longitudinal tests with the maximum recommended slope indicated on the decal. Review the instructions for operating the machine on slopes in the *Operator's Manual* as well as the conditions in which you would operate the machine to determine whether you can operate the machine in the conditions on that day and at that site. Changes in the terrain can result in a change in slope operation for the machine. If possible, keep the cutting units lowered to the ground while operating the machine on slopes. Raising the cutting units while operating on slopes can cause the machine to become unstable.

1. Warning—read the *Operator's Manual*; all operators should be trained before operating the machine.
2. Warning—read the *Operator's Manual* before towing the machine.
3. Tipping hazard—do not turn sharply while traveling fast; do not drive up or down slopes greater than 22°; lower the cutting units when driving down slopes; use a rollover protection system and wear the seatbelt.
4. Warning—do not park the machine on slopes; engage the parking brake, lower the cutting units, shut off the engine, and remove the key before leaving the machine.
5. Thrown object hazard—keep bystanders away.
6. Entanglement hazard, belt—stay away from moving parts; keep all guards and shields in place.



138-1186

decal138-1186

**Note:** This machine complies with the industry standard stability test in the static lateral and longitudinal tests with the maximum recommended slope indicated on the decal. Review the instructions for operating the machine on slopes in the *Operator's Manual* as well as the conditions in which you would operate the machine to determine whether you can operate the machine in the conditions on that day and at that site. Changes in the terrain can result in a change in slope operation for the machine. If possible, keep the cutting units lowered to the ground while operating the machine on slopes. Raising the cutting units while operating on slopes can cause the machine to become unstable.

- |  |  |
|--|--|
| <ol style="list-style-type: none"> <li>1. Warning—read the <i>Operator's Manual</i>; all operators should be trained before operating the machine.</li> <li>2. Warning—read the <i>Operator's Manual</i> before towing the machine.</li> <li>3. Tipping hazard—do not turn sharply while traveling fast; do not drive up or down slopes greater than 16°; lower the cutting units when driving down slopes; use a rollover protection system and wear the seatbelt.</li> </ol> | <ol style="list-style-type: none"> <li>4. Warning—do not park the machine on slopes; engage the parking brake, lower the cutting units, shut off the engine, and remove the key before leaving the machine.</li> <li>5. Thrown object hazard—keep bystanders away.</li> <li>6. Entanglement hazard, belt—stay away from moving parts; keep all guards and shields in place.</li> </ol> |
|--|--|

## REELMASTER 3550-D

### QUICK REFERENCE AID

**CHECK/SERVICE (DAILY)**

1. OIL LEVEL, ENGINE
2. ENGINE OIL DRAIN (3/4" OR 19mm SOCKET)
3. OIL LEVEL HYDRAULIC TANK
4. COOLANT LEVEL, RADIATOR
5. FUEL/WATER SEPARATOR
6. AIR CLEANER
7. RADIATOR SCREEN
8. PARKING BRAKE
9. TIRE PRESSURE (12 psi)
10. BATTERY
11. BELTS (FAN, ALTERNATOR, HYDRAULIC PUMP)
12. REEL SPEED & BACKLAP CONTROL

GREASING - SEE OPERATOR'S MANUAL

#### FLUID SPECIFICATIONS/CHANGE INTERVALS

SEE OPERATOR'S MANUAL FOR INITIAL CHANGES.	FLUID TYPE	CAPACITY	CHANGE INTERVAL		FILTER PART NO.
			FLUID	FILTER	
A. ENGINE OIL	SAE 15W-40 CH-4	4.0 QTS.*	150 HRS.	150 HRS.	108-3841
B. HYD. CIRCUIT OIL	SEE OPERATOR'S MANUAL	6 GAL.*	2000 HRS.	1000 HRS.	86-3010
C. AIR CLEANER				200 HRS.	108-3811
D. WATER SEPARATOR				400 HRS.	110-9049
E. FUEL TANK	NO. 2-DIESEL	7.5 GALS.	DRAIN AND FLUSH, 2 YRS.		
F. COOLANT	50/50 ETHYLENE GLYCOL/WATER	6 QTS.	DRAIN AND FLUSH, 2 YRS.		

\* INCLUDING FILTER

**FUSES**

TEC-5002	2A	7.5A	7.5A	7.5A
15A	10A	10A	10A	10A

138-6980

138-6980

decal138-6980

1. Read the *Operator's Manual*.

Models 03820 and 03821

## REELMASTER 3555-D / 3575-D

### QUICK REFERENCE AID

**CHECK/SERVICE (DAILY)**

1. OIL LEVEL, ENGINE
2. ENGINE OIL DRAIN (3/4" OR 19mm SOCKET)
3. OIL LEVEL HYDRAULIC TANK
4. COOLANT LEVEL, RADIATOR
5. FUEL/WATER SEPARATOR
6. AIR CLEANER
7. RADIATOR SCREEN
8. PARKING BRAKE
9. TIRE PRESSURE: RM 3555-D (12 psi) RM 3575-D (20 psi)
10. BATTERY
11. BELTS (FAN, ALTERNATOR, HYDRAULIC PUMP)
12. REEL SPEED & BACKLAP CONTROL

GREASING - SEE OPERATOR'S MANUAL

#### FLUID SPECIFICATIONS/CHANGE INTERVALS

SEE OPERATOR'S MANUAL FOR INITIAL CHANGES.	FLUID TYPE	CAPACITY	CHANGE INTERVAL		FILTER PART NO.
			FLUID	FILTER	
(A) ENGINE OIL	SAE 15W-40 CH-4	4.0 QTS.*	150 HRS.	150 HRS.	108-3841
(B) HYD. CIRCUIT OIL	SEE OPERATOR'S MANUAL	6 GAL.*	2000 HRS.	1000 HRS.	86-3010
(C) AIR CLEANER				200 HRS.	108-3811
(D) WATER SEPARATOR				400 HRS.	110-9049
(E) FUEL TANK	NO. 2-DIESEL	7.5 GALS.	DRAIN AND FLUSH, 2 YRS.		
(F) COOLANT	50/50 ETHYLENE GLYCOL/WATER	6 QTS.	DRAIN AND FLUSH, 2 YRS.		

\* INCLUDING FILTER

**FUSES**

TEC-5002	2A	7.5A	7.5A	7.5A
15A	10A	10A	10A	10A

138-6981

138-6981

decal138-6981

1. Read the *Operator's Manual*.



### Battery Symbols

Some or all of these symbols are on your battery.

- |  |   |
|--|---|
| 1. Explosion hazard                    | 6. Keep bystanders away from the battery.                                       |
| 2. No fire, open flame, or smoking     | 7. Wear eye protection; explosive gases can cause blindness and other injuries. |
| 3. Caustic liquid/chemical burn hazard | 8. Battery acid can cause blindness or severe burns.                            |
| 4. Wear eye protection.                | 9. Flush eyes immediately with water and get medical help fast.                 |
| 5. Read the <i>Operator's Manual</i> . | 10. Contains lead; do not discard   |

# Setup

## Loose Parts

Use the chart below to verify that all parts have been shipped.

Procedure	Description	Qty.	Use
<b>1</b>	Right hose guide (Models 03820 and 03821)	1	Install the cutting units.
	Left hose guide (Models 03820 and 03821)	1	
<b>2</b>	No parts required	–	Adjust the turf compensation spring.
<b>3</b>	Warning decal 121-7928 (machine model 03910)	1	Install the CE decals, if required.
	Warning decal 138-1186 (machine models 03820 and 03821)	1	
	CE decal	1	
	Production year decal	1	
<b>4</b>	Lock bracket	1	Install the hood latch (CE only).
	Rivet	2	
	Washer	1	
	Screw (1/4 x 2 inches)	1	
	Locknut (1/4 inch)	1	
<b>5</b>	No parts required	–	Reduce the tire pressure.
<b>6</b>	Cutting-unit kickstand	1	Use the cutting-unit kickstand.

## Media and Additional Parts

Description	Qty.	Use
Keys	2	Start the engine.
Operator's Manual	1	Read the manuals before operating the machine.
Engine owner's manual	1	
Cutting performance paper	1	Use the paper for adjusting the cutting unit reel-to-bedknife contact.
Shim	1	Use the shim for adjusting the cutting unit reel-to-bedknife contact.

**Note:** Determine the left and right sides of the machine from the normal operating position.

# 1

## Installing the Cutting Units

Parts needed for this procedure:

1	Right hose guide (Models 03820 and 03821)
1	Left hose guide (Models 03820 and 03821)

## Preparing the Machine and Cutting Units

1. Park the machine on a level surface, engage the parking brake, shut off the engine, and remove the key from the ignition switch.
2. Remove the reel motors from the shipping brackets.
3. Remove and discard the shipping brackets.
4. Remove the cutting units from the cartons. Assemble and adjust them as described in the cutting unit *Operator's Manual*.
5. Make sure that the counterweight (Figure 3) is installed to the proper end of the cutting unit as described in the cutting unit *Operator's Manual*.

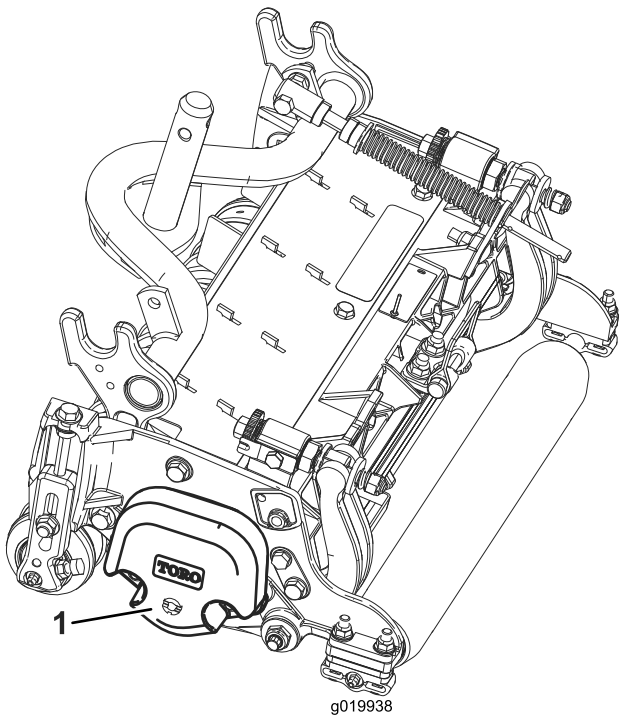


Figure 3

1. Counterweight

## Positioning the Turf Compensating Spring

All the cutting units are shipped with the turf compensation spring mounted at the right side of the cutting unit. Ensure that the turf compensation spring is mounted to the same side of the cutting unit as the reel drive motor.

**Note:** When installing or removing the cutting units, make sure that the hairpin cotter is installed in the spring rod hole next to the rod bracket. Otherwise, install the hairpin cotter in the hole in the end of the rod.

1. Remove the 2 carriage bolts and nuts securing the rod bracket to the cutting unit tabs (Figure 4).

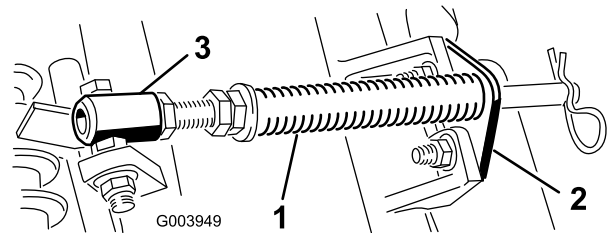


Figure 4

1. Turf compensation spring
2. Rod bracket
3. Spring tube

2. Remove the flange nut securing the spring tube bolt to the carrier frame tab (Figure 4), and remove the assembly.
3. Mount the spring tube bolt to the opposite tab on the carrier frame and secure it with the flange nut.

**Note:** Position the bolt head to the outer side of the tab as shown in Figure 4.

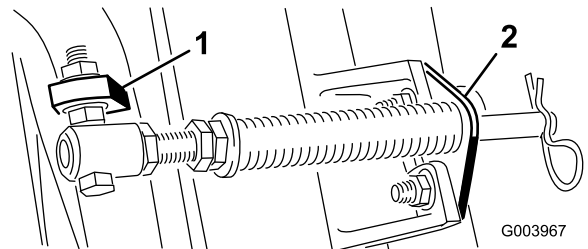


Figure 5

1. Opposite carrier frame tab
2. Rod bracket

4. Mount the rod bracket to the cutting unit tabs with the carriage bolts and nuts (Figure 5).

# Installing the Hose Guide

## Models 03820 and 03821

On cutting unit 4 (left front) and cutting unit 5 (right front), use the rod-bracket mounting nuts to install the hose guides to the front of the cutting-unit tabs. The hose guides should lean toward the center cutting unit (Figure 6, Figure 7, and Figure 8).

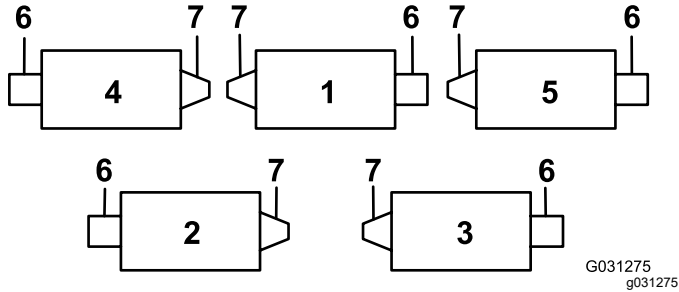


Figure 6

- |                   |                   |
|-------------------|-------------------|
| 1. Cutting unit 1 | 5. Cutting unit 5 |
| 2. Cutting unit 2 | 6. Reel motor     |
| 3. Cutting unit 3 | 7. Weight         |
| 4. Cutting unit 4 |                   |

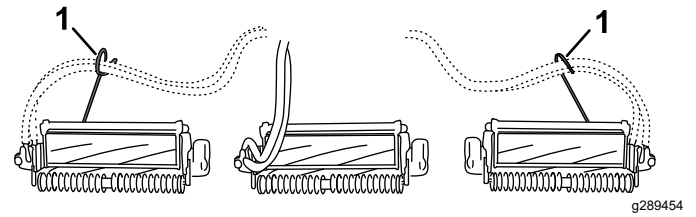


Figure 8

1. Hose guides (each must lean toward the center cutting unit)

## Aligning the Cutting Units to the Lift Arms

All Front Cutting Units, and Any Rear Cutting Units with a 1.2 cm (3/4 inch) or Lower Height of Cut

1. Lower all the lift arms completely.
2. Remove the snapper pin and the cap from the lift-arm pivot yoke (Figure 9).

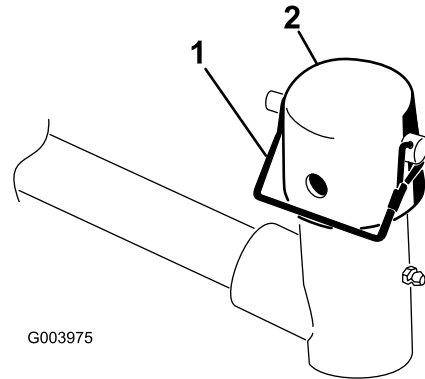


Figure 9

1. Snapper pin
2. Cap

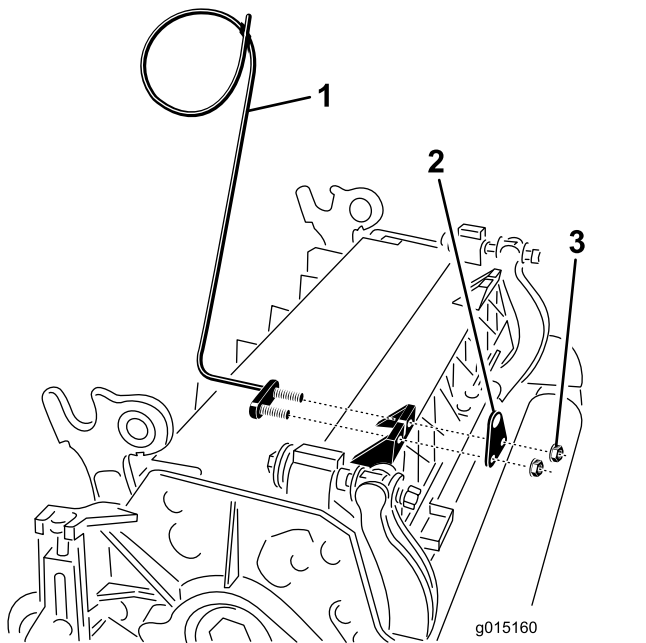
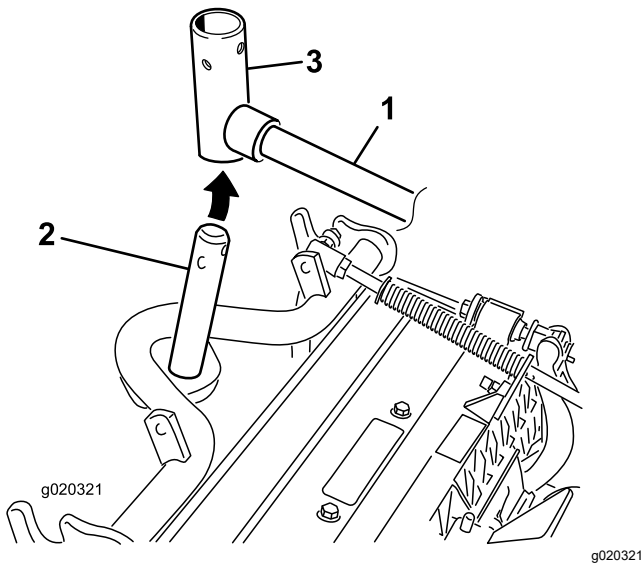


Figure 7

1. Hose guide (left side shown)
2. Rod bracket
3. Nuts



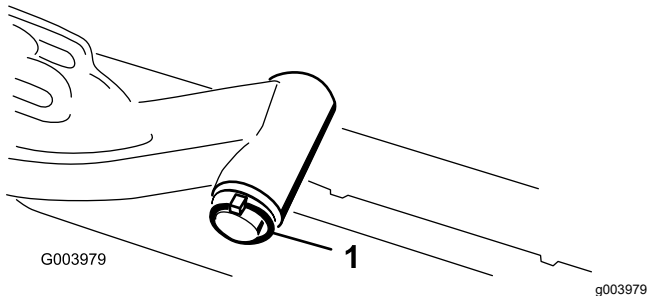
**Figure 10**

1. Lift arm
2. Carrier frame shaft
3. Lift-arm pivot yoke

## Aligning the Rear Cutting Units to the Lift Arms

Cutting Units adjusted for a 1.2 cm (3/4 inch) or Higher Height of Cut

1. Remove the lynch pin and washer securing the lift-arm pivot shaft to the lift arm and slide the lift-arm pivot shaft out of the lift arm (Figure 11).



**Figure 11**

1. Lift-arm shaft lynch pin and washer

2. Insert the lift-arm yoke onto the carrier frame shaft (Figure 10).
3. Insert the lift-arm shaft into the lift arm and secure it with the washer and lynch pin (Figure 11).

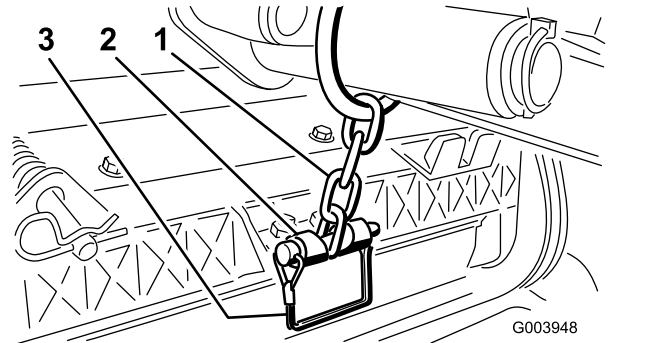
## Assembling the Cutting Units to the Lift Arms

1. Insert the cap over the carrier frame shaft and lift-arm yoke.
2. Secure the cap and the carrier frame shaft to the lift-arm yoke with the snapper pin.

**Note:** Use the slot if a steering cutting unit is desired or use the hole if the cutting unit is to be locked in position (Figure 9).

3. Secure the lift-arm chain to the chain bracket with the snapper pin (Figure 12).

**Note:** Use the number of chain links specified in the cutting unit *Operator's Manual*.



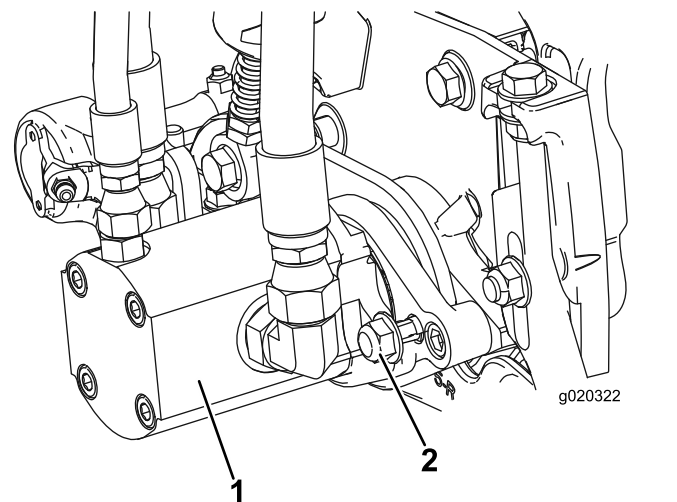
**Figure 12**

1. Lift-arm chain
2. Chain bracket
3. Snapper pin

## Installing the Reel Motors

1. Coat the spline shaft of the reel motor with clean grease.
2. Lubricate the reel-motor O-ring with oil, and install it onto the motor flange.
3. Install the motor by rotating it clockwise so that the motor flanges clear the locknuts (Figure 13).

**Important:** Ensure that the reel motor hoses are not twisted, kinked, or at risk of being pinched.



**Figure 13**

1. Reel-drive motor
2. Mounting nuts



4. Rotate the motor counterclockwise until the flanges encircle the nuts.
5. Torque the nuts to 37 to 45 N·m (27 to 33 ft-lb).

# 2

## Adjusting the Turf Compensation Spring

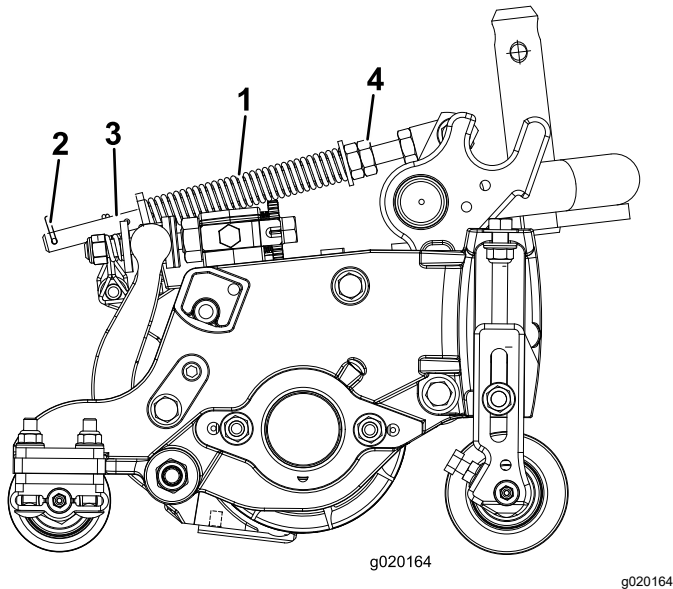
**No Parts Required**

### Procedure

The turf compensation spring (Figure 14) transfers weight from the front to the rear roller. This helps to reduce a wave pattern in the turf, also known as marcelling or bobbing.

**Important:** Make spring adjustments with the cutting unit mounted to the traction unit, pointing straight ahead and lowered to the shop floor.

1. Make sure that the hairpin cotter is installed in the rear hole in the spring rod (Figure 14).



**Figure 14**

- |                             |               |
|-----------------------------|---------------|
| 1. Turf compensation spring | 3. Spring rod |
| 2. Hairpin cotter           | 4. Hex nuts   |

2. Tighten the hex nuts on the front end of the spring rod until the compressed length of the spring (Figure 14) is 12.7 cm (5 inches) for 5-inch cutting units and 15.8 cm (6-1/4 inches) for 7-inch cutting units.

**Note:** When operating on rough terrain, decrease the spring length by 2.5 cm (1/2 inch). Ground following will be slightly decreased.

# 3

## Installing the CE Decals

**Parts needed for this procedure:**

1	Warning decal 121-7928 (machine model 03910)
1	Warning decal 138-1186 (machine models 03820 and 03821)
1	CE decal
1	Production year decal

### Procedure

On machines requiring CE compliance, apply the production year decal (Part No. 133-5615) near the serial plate, the CE decal (Part No. 93-7252) near the hood lock, and the CE warning decal (Part No. 121-7928 for machine model 03910 and Part No. 138-1186 for machine models 03820 and 03821) over the standard warning decal (Part No. 120-1683).

# 4

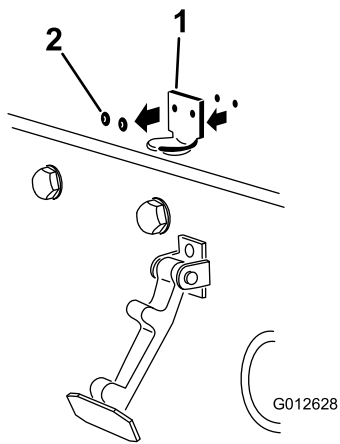
## Installing the Hood Latch (CE Only)

**Parts needed for this procedure:**

1	Lock bracket
2	Rivet
1	Washer
1	Screw (1/4 x 2 inches)
1	Locknut (1/4 inch)

### Procedure

1. Unhook the hood latch from the hood-latch bracket.
2. Remove the 2 rivets securing the hood-latch bracket to the hood (Figure 15) and remove the hood-latch bracket from the hood.



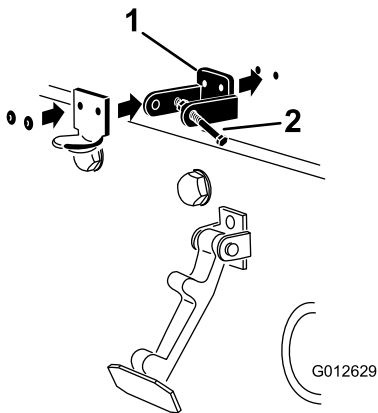
**Figure 15**

g012628

1. Hood-latch bracket
2. Rivets

3. While aligning the mounting holes, position the CE lock bracket and the hood-latch bracket onto the hood.

**Note:** The lock bracket must be against the hood (Figure 16). Do not remove the bolt and nut from the lock-bracket arm.

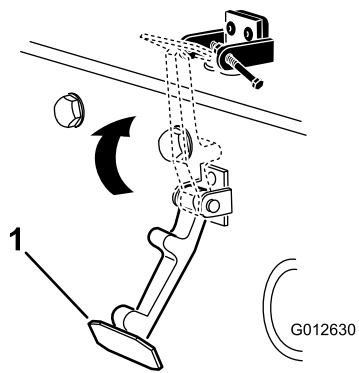


**Figure 16**

g012629

1. CE lock bracket
2. Bolt and nut

4. Align the washers with the holes on the inside of the hood.
5. Rivet the brackets and the washers to the hood (Figure 16).
6. Hook the latch onto the hood-latch bracket (Figure 17).



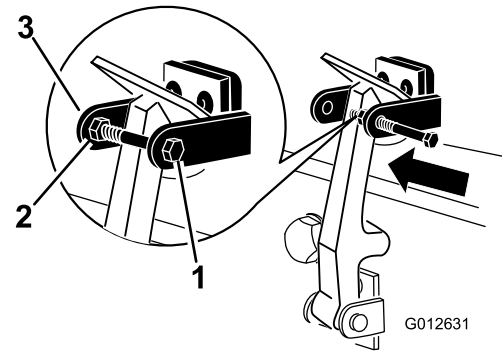
**Figure 17**

g012630

1. Hood latch

7. Screw the bolt into the other arm of the hood-lock bracket to lock the latch in position (Figure 18).

**Note:** Tighten the bolt securely but do not tighten the nut.



**Figure 18**

g012631

1. Bolt
2. Nut
3. Arm of hood-lock bracket

# 5

## Reducing the Tire Pressure

**No Parts Required**

### Procedure

The tires are overinflated at the factory for shipping purposes. Reduce the pressure to the proper levels before starting the machine; refer to [Checking the Tire Pressure](#) (page 45).

# 6

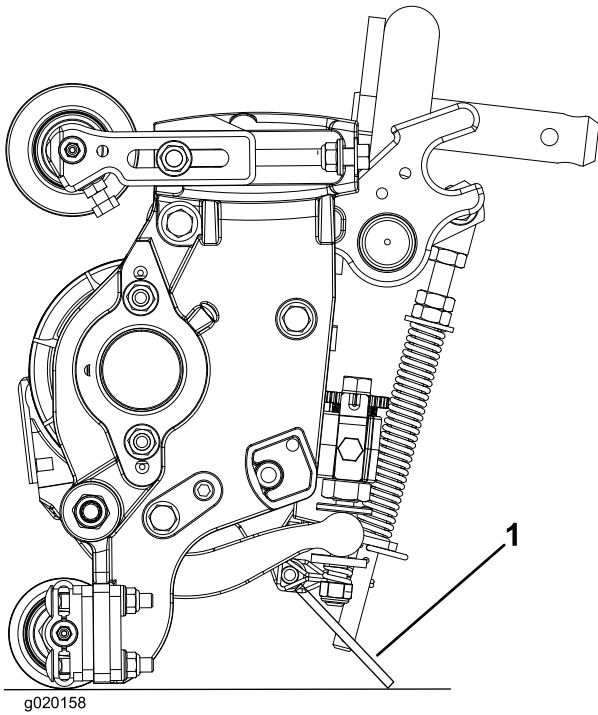
## Using the Cutting-Unit Kickstand

Parts needed for this procedure:

1	Cutting-unit kickstand
---	------------------------

### Procedure

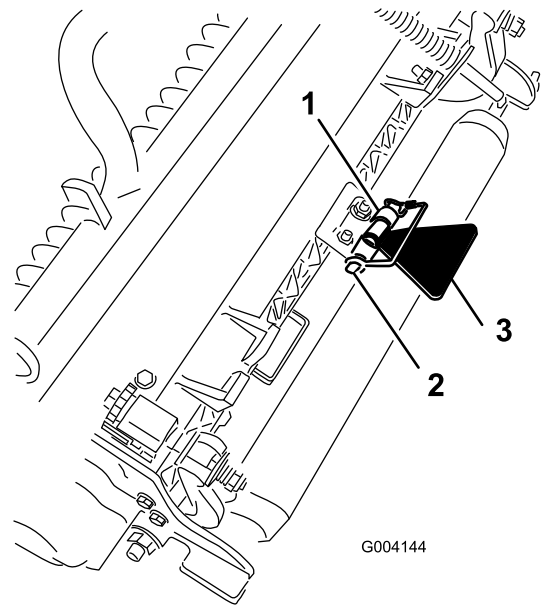
Whenever you tip a cutting unit to expose the bedknife/reel, prop up the rear of the cutting unit with the kickstand to ensure that the nuts on the back end of the bedbar adjusting screws are not resting on the work surface (Figure 19).



**Figure 19**

1. Cutting-unit kickstand

Secure the kickstand to the chain bracket with the snapper pin (Figure 20).



**Figure 20**

1. Chain bracket
2. Snapper pin
3. Cutting-unit kickstand

# Product Overview

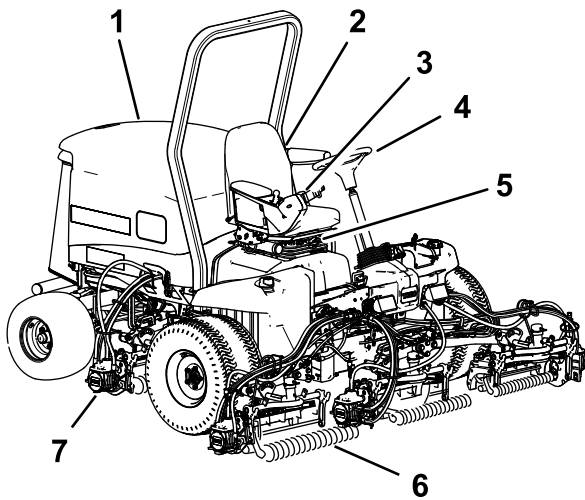


Figure 21

g216864

- |                   |                          |
|-------------------|--------------------------|
| 1. Engine hood    | 5. Seat adjustment lever |
| 2. Seat           | 6. Front cutting units   |
| 3. Control arm    | 7. Rear cutting units    |
| 4. Steering wheel |                          |

## Mow/Transport Slide

Using your heel, move the mow/transport slide (Figure 22) to the left to transport and to the right to mow. The cutting units will only operate in the Mow position and not lower in the TRANSPORT position.

**Important:** The mow speed is set at the factory to 9.7 km/h (6 mph). It can be increased or decreased by adjusting the speed stop screw (Figure 23).

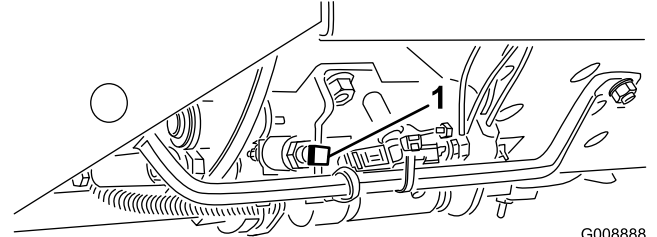


Figure 23

G008888  
g008888

1. Speed stop screw

## Controls

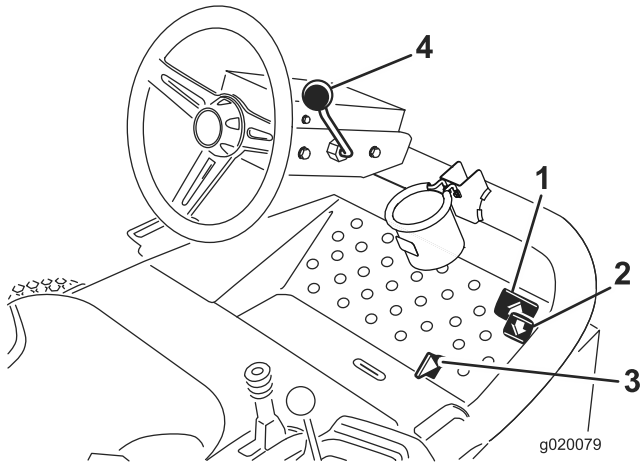


Figure 22

g020079

g020079

- |                           |                        |
|---------------------------|------------------------|
| 1. Forward traction pedal | 3. Mow/transport slide |
| 2. Reverse traction pedal | 4. Tilt-steering lever |

## Tilt-Steering Lever

Pull the tilt-steering lever (Figure 22) back to tilt the steering wheel to the desired position. Then push the lever forward to secure the position.

## Ignition Switch

The ignition switch (Figure 24), used to start, shut off, and preheat the engine, has 3 positions: OFF, ON/PREHEAT, and START. Rotate the key to the ON/PREHEAT position until the glow-plug indicator light goes out (approximately 7 seconds); then rotate the key to the START position to engage the starter motor. Release the key when the engine starts. The key moves automatically to the ON/RUN position. To shut off the engine, rotate the key to the OFF position. Remove the key from the switch to prevent accidental starting.

## Traction Pedals

Press the forward traction pedal (Figure 22) to move forward. Press reverse traction pedal (Figure 22) to move backward or to assist in stopping when moving forward. Also, allow the pedal to move or move it to the NEUTRAL position to stop the machine.

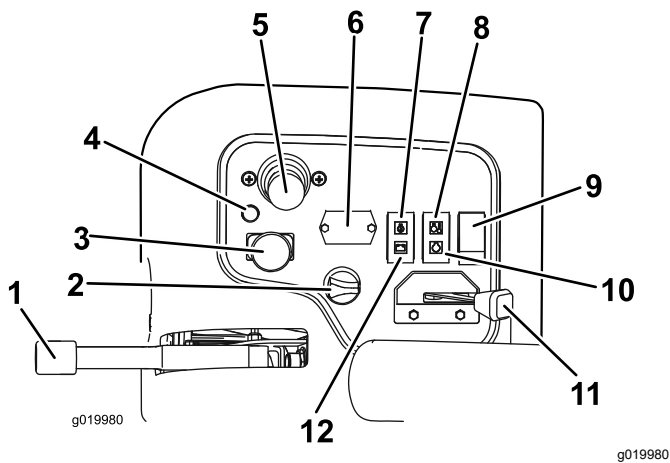


Figure 24

- |                                  |                               |
|----------------------------------|-------------------------------|
| 1. Parking brake                 | 7. Oil-pressure light         |
| 2. Ignition switch               | 8. Temperature light          |
| 3. Enable/Disable switch         | 9. Light switch               |
| 4. Diagnostic light              | 10. Glow-plug indicator light |
| 5. Lower mow/raise control lever | 11. Throttle                  |
| 6. Hour meter                    | 12. Alternator light          |

## Throttle

Move the throttle (Figure 24) forward to increase the engine speed and rearward to decrease the engine speed.

## Enable/Disable Switch

Use the enable/disable switch (Figure 24) in conjunction with the lower mow/raise control lever to operate the cutting units. **You cannot lower the cutting units when the mow/transport lever is in the TRANSPORT position.**

## Hour Meter

The hour meter (Figure 24) indicates the total hours of machine operation. It starts to function whenever the key switch is on.

## Lower Mow/Raise Control Lever

This lever (Figure 24) raises and lowers the cutting units and also starts and stops the reels when the reels are enabled in the mow mode. **You cannot lower the cutting units when the mow/transport lever is in the TRANSPORT position.**

**Note:** When the cutting units are enabled, you do not need to hold the lever in the forward position while the cutting units are lowered or raised.

## Engine Coolant Temperature Warning Light

The temperature warning light (Figure 24) glows if the engine coolant temperature is high. At this temperature, the cutting units are disabled. If the coolant temperature rises another 5.5° C (10° F), the engine shuts off to prevent further damage.

## Oil-Pressure Warning Light

The oil-pressure warning light (Figure 24) glows if the engine oil pressure drops below a safe level.

## Alternator Light

The alternator light (Figure 24) should be off when the engine is running. If it is on, check the charging system and repair it as necessary.

## Glow-Plug Indicator

The glow-plug indicator light (Figure 24) glows when the glow plugs are operating.

## Parking Brake

Whenever the engine is shut off, engage the parking brake (Figure 24) to prevent accidental movement of the machine. To engage the parking brake, pull up on the lever. The engine stops when you press the traction pedal with the parking brake engaged.

## Diagnostic Light

The diagnostic light (Figure 24) will illuminate if the system recognizes a system fault.

## Fuel Gauge

The fuel gauge (Figure 25) indicates the amount of fuel in the tank.

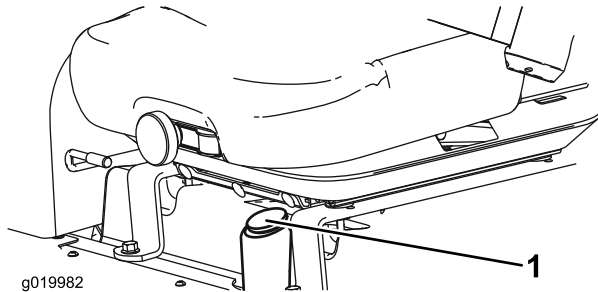


Figure 25

1. Fuel gauge

## Power Point

The power point, located on the outside of the control panel, is a 12 V power supply for electronic devices (Figure 26).

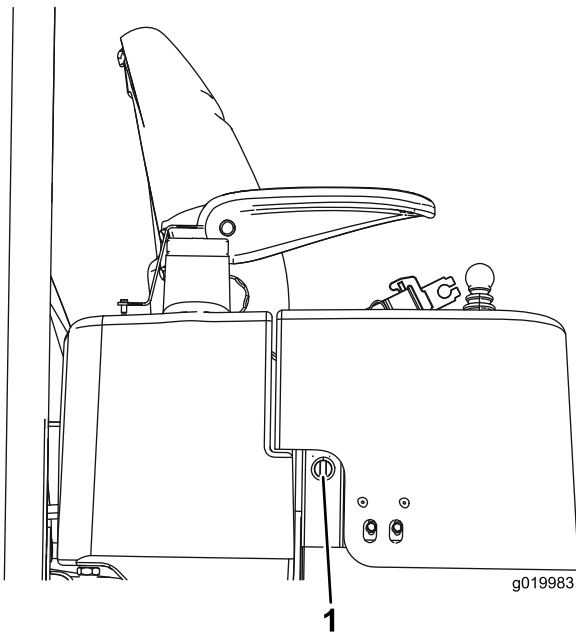


Figure 26

1. Power point

## Reel Speed Control Knob

The reel speed control controls the speed of the cutting units (Figure 27). The reel speed increases as you turn the knob counterclockwise. Refer to the reel speed chart decal (Figure 31), to determine the proper reel speed.

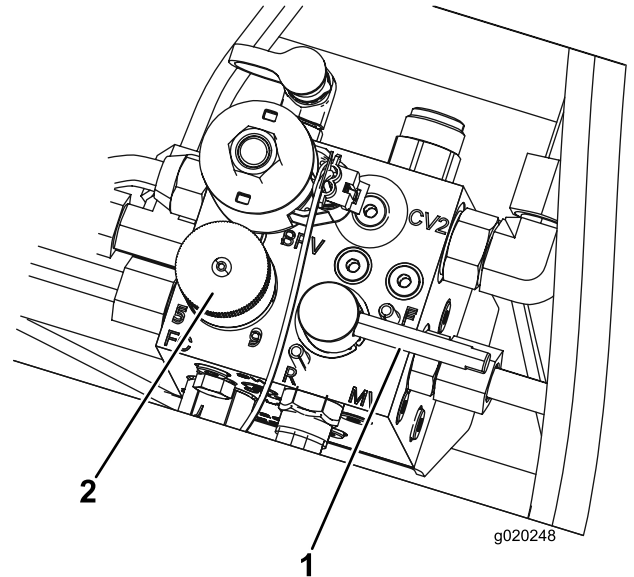


Figure 27

1. Backlap lever
2. Reel speed control knob

## Backlap Lever

Use the backlap lever in conjunction with the lower mow/raise control lever for the reels (Figure 27).

# Specifications

**Note:** Specifications and design are subject to change without notice.

Dimensions	Reelmaster 3550	Reelmaster 3555	Reelmaster 3575
Width of Cut	208 cm (82 inches)	254 cm (100 inches)	254 cm (100 inches)
Overall Width	239 cm (94 inches)	284 cm (112 inches)	284 cm (112 inches)
Transport Width	231 cm (91 inches)	231 cm (91 inches)	231 cm (91 inches)
Overall Length	295 cm (110 inches)	267 cm (105 inches)	267 cm (105 inches)
Height to top of ROPS	188 cm (74 inches)	201 cm (79 inches)	206 cm (81 inches)
Wheel Base	151 cm (59.5 inches)	152 cm (60 inches)	152 cm (60 inches)
Weight (configured)	900 kg (1985 lb)	1034 kg (2280 lb)	1157 kg (2550 lb)
Weight (no cutting units)	708 kg (1560 lb)	751 kg (1655 lb)	796 kg (1755 lb)

## Attachments/Accessories

A selection of Toro approved attachments and accessories is available for use with the machine to enhance and expand its capabilities. Contact your Authorized Service Dealer or authorized Toro distributor or go to [www.Toro.com](http://www.Toro.com) for a list of all approved attachments and accessories.

To ensure optimum performance and continued safety certification of the machine, use only genuine Toro replacement parts and accessories. Replacement parts and accessories made by other manufacturers could be dangerous, and such use could void the product warranty.

# Operation

## *Before Operation*

## Before Operation Safety

### General Safety

- Never allow children or untrained people to operate or service the machine. Local regulations may restrict the age of the operator. The owner is responsible for training all operators and mechanics.
- Become familiar with the safe operation of the equipment, operator controls, and safety signs.
- Shut off the engine, remove the key, and wait for all movement to stop before you leave the operator's position. Allow the machine to cool before adjusting, servicing, cleaning, or storing it.
- Know how to stop the machine and shut off the engine quickly.
- Do not operate the machine without all guards and other safety protective devices in place and functioning properly on the machine.

- Before mowing, always inspect the machine to ensure that the cutting units are in good working condition.
- Inspect the area where you will use the machine and remove all objects that the machine could throw.

### Fuel Safety

- Use extreme care in handling fuel. It is flammable and its vapors are explosive.
- Extinguish all cigarettes, cigars, pipes, and other sources of ignition.
- Use only an approved fuel container.
- Do not remove the fuel cap or fill the fuel tank while the engine is running or hot.
- Do not add or drain fuel in an enclosed space.
- Do not store the machine or fuel container where there is an open flame, spark, or pilot light, such as on a water heater or other appliance.
- If you spill fuel, do not attempt to start the engine; avoid creating any source of ignition until the fuel vapors have dissipated.

# Performing Daily Maintenance

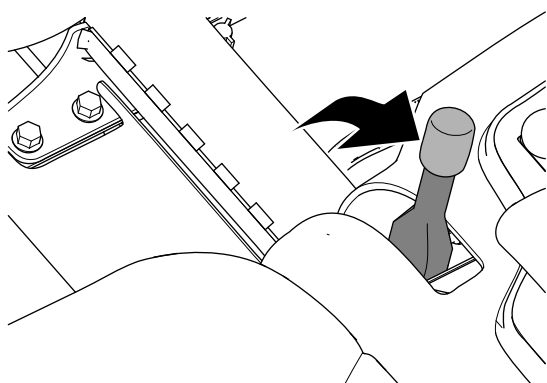
**Service Interval:** Before each use or daily

Before starting the machine each day, perform the Each Use/Daily procedures listed in [Maintenance \(page 35\)](#).

## Checking the Parking Brake

**Service Interval:** Before each use or daily

1. Start the engine, raise the cutting units, disengage the parking brake, and move the machine to an open flat area.
2. Engage the parking brake ([Figure 28](#)).



**Figure 28**

g332418

3. Press the traction pedal to move the machine forward.

**Note:** If the machine moves forward with the parking brake engaged, adjust parking brake; refer to [Adjusting the Parking Brake \(page 47\)](#).

**Note:** Moving the machine forward with the parking brake engaged will cause the engine to shutoff.

4. If you adjusted the parking brake, repeat steps [2](#) and [3](#).

**Note:** If the machine moves forward with the parking brake engaged: service the parking brakes, check left and right brake linkage for damage, and check the brake lever pivot for damage; refer to [Servicing the Parking Brakes \(page 47\)](#).

5. Shut off the engine, remove the key, and wait for all moving parts to stop before leaving the operator's seat.

# Filling the Fuel Tank

Use only clean, fresh diesel fuel or biodiesel fuels with low (<500 ppm) or ultra-low (<15 ppm) sulfur content. The minimum cetane rating should be 40. Purchase fuel in quantities that can be used within 180 days to ensure fuel freshness.

The fuel tank capacity is approximately 42 L (11 US gallons).

Use summer-grade diesel fuel (Number 2-D) at temperatures above -7°C (20°F) and winter-grade diesel fuel (Number 1-D or Number 1-D/2-D blend) below -7°C (20°F). Using winter-grade fuel at lower temperatures provides lower flash point and cold flow characteristics which will ease starting and reduce plugging of the fuel filter.

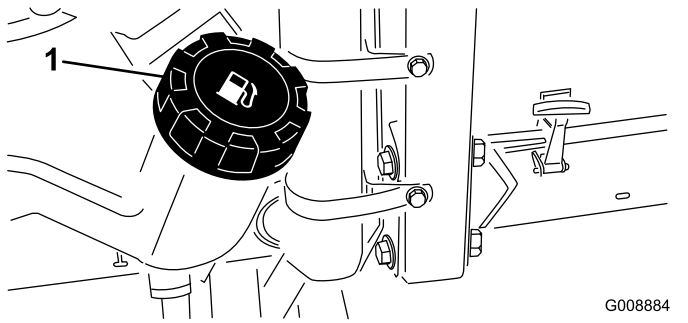
Using summer-grade fuel above -7°C (20°F) will contribute toward longer fuel-pump life and increased power compared to winter-grade fuel.

The machine is **biodiesel ready**.

This machine can also use a biodiesel blended fuel of up to B20 (20% biodiesel, 80% petrodiesel). The petrodiesel portion should be low or ultra-low sulfur. Observe the following precautions:

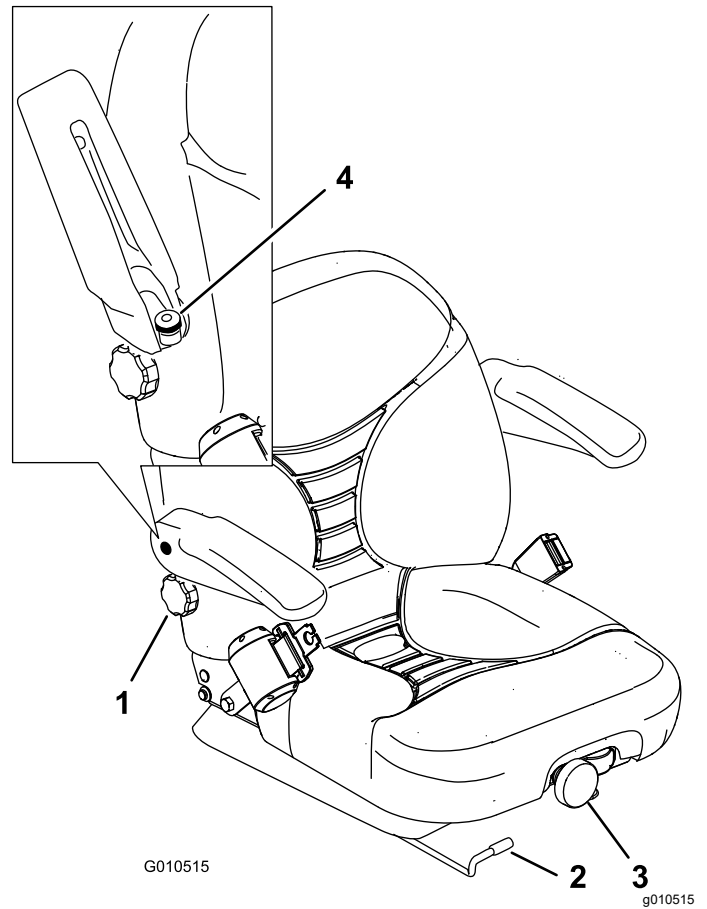
- The biodiesel portion of the fuel must meet specification ASTM D6751 or EN14214.
  - The blended fuel composition should meet ASTM D975 or EN590.
  - Painted surfaces may be damaged by biodiesel blends.
  - Use B5 (biodiesel content of 5%) or lesser blends in cold weather.
  - Monitor seals, hoses, and gaskets in contact with fuel as they may degrade over time.
  - Expect plugging of the fuel filter for a time after converting to biodiesel blends.
  - Contact your authorized Toro distributor if you wish for more information on biodiesel.
1. Park the machine on a level surface, lower the cutting units, engage the parking brake, shut off the engine, and remove the key from the ignition switch.
  2. Clean the area around the fuel-tank cap ([Figure 29](#)).
  3. Remove the fuel-tank cap.
  4. Fill the tank to the bottom of the filler neck. **Do not overfill the tank.**
  5. Install the cap.
  6. To prevent a fire hazard, wipe up any fuel that may have spilled.





**Figure 29**

1. Fuel-tank cap



**Figure 30**

1. Backrest knob
2. Seat-position adjustment lever
3. Seat-suspension knob
4. Armrest-adjusting knob

## Adjusting the Seat

### Changing the Seat Position

The seat can move forward and backward. Position the seat where you have the best control of the machine and are most comfortable.

1. Move the lever sideways to unlock the seat ([Figure 30](#)).
2. Slide the seat to the desired position and release the lever to lock it in position.

### Changing the Seat Suspension

You can adjust the seat to provide a smooth and comfortable ride. Position the seat where you are most comfortable.

To adjust it, turn the front knob in either direction to provide the best comfort ([Figure 30](#)).

### Changing the Back Position

You can adjust the back of the seat to provide a comfortable ride. Position the back of the seat where it is most comfortable.

To adjust it, turn the knob under the right armrest, in either direction, to provide the best comfort ([Figure 30](#)).

### Changing the Armrest Position

You can adjust the armrests to provide a comfortable ride. Position the armrests where they are most comfortable.

Raise the armrest and turn the knob, in either direction, to provide the best comfort ([Figure 30](#)).

# ***During Operation***

## **During Operation Safety**

### **General Safety**

- The owner/operator can prevent and is responsible for accidents that may cause personal injury or property damage.
- Wear appropriate clothing, including eye protection; long pants; substantial, slip-resistant footwear; and hearing protection. Tie back long hair and do not wear loose clothing or loose jewelry.
- Do not operate the machine while ill, tired, or under the influence of alcohol or drugs.
- Use your full attention while operating the machine. Do not engage in any activity that causes distractions; otherwise, injury or property damage may occur.
- Before you start the engine, ensure that all drives are in neutral, the parking brake is engaged, and you are in the operating position.
- Do not carry passengers on the machine and keep bystanders and children out of the operating area.
- Operate the machine only in good visibility to avoid holes or hidden hazards.
- Avoid mowing on wet grass. Reduced traction could cause the machine to slide.
- Keep your hands and feet away from the cutting units.
- Look behind and down before backing up to be sure of a clear path.
- Use care when approaching blind corners, shrubs, trees, or other objects that may obscure your vision.
- Stop the cutting units whenever you are not mowing.
- Slow down and use caution when making turns and crossing roads and sidewalks with the machine. Always yield the right-of-way.
- Operate the engine only in well-ventilated areas. Exhaust gases contain carbon monoxide, which is lethal if inhaled.
- Do not leave a running machine unattended.
- Before you leave the operator's position, do the following:
  - Park the machine on a level surface.
  - Disengage the cutting unit(s) and lower the attachments.
  - Engage the parking brake.
  - Shut off the engine and remove the key.

- Wait for all movement to stop.

- Operate the machine only in good visibility and appropriate weather conditions. Do not operate the machine when there is the risk of lightning.

### **Rollover Protection System (ROPS) Safety**

- Do not remove any of the ROPS components from the machine.
- Ensure that the seat belt is attached and that you can release it quickly in an emergency.
- Always wear your seat belt.
- Check carefully for overhead obstructions and do not contact them.
- Keep the ROPS in safe operating condition by thoroughly inspecting it periodically for damage and keeping all the mounting fasteners tight.
- Replace all damaged ROPS components. Do not repair or alter them.

### **Slope Safety**

- Slopes are a major factor related to loss of control and rollover accidents, which can result in severe injury or death. You are responsible for safe slope operation. Operating the machine on any slope requires extra caution.
- Evaluate the site conditions to determine if the slope is safe for machine operation, including surveying the site. Always use common sense and good judgment when performing this survey.
- Review the slope instructions, listed below, for operating the machine on slopes. Before you operate the machine, review the site conditions to determine whether you can operate the machine in the conditions on that day and at that site. Changes in the terrain can result in a change in slope operation for the machine.
  - Avoid starting, stopping, or turning the machine on slopes. Avoid making sudden changes in speed or direction. Make turns slowly and gradually.
  - Do not operate a machine under any conditions where traction, steering, or stability is in question.
  - Remove or mark obstructions such as ditches, holes, ruts, bumps, rocks, or other hidden hazards. Tall grass can hide obstructions. Uneven terrain could overturn the machine.
  - Be aware that operating the machine on wet grass, across slopes, or downhill may cause the machine to lose traction.
  - Use extreme caution when operating the machine near drop-offs, ditches,

embankments, water hazards, or other hazards. The machine could suddenly roll over if a wheel goes over the edge or the edge caves in. Establish a safety area between the machine and any hazard.

- Identify hazards at the base of the slope. If there are hazards, mow the slope with a pedestrian-controlled machine.
- If possible, keep the cutting units lowered to the ground while operating on slopes. Raising the cutting units while operating on slopes can cause the machine to become unstable.

## Starting the Engine

You may need to bleed the fuel system if any of the following situations have occurred; refer to [Bleeding the Fuel System \(page 29\)](#):

- Initial startup of a new engine
  - The engine has ceased running due to lack of fuel.
  - Maintenance has been performed upon the fuel system components; i.e. filter replaced, etc.
1. Ensure that the parking brake is engaged and the cutting unit drive switch is in the DISENGAGE position.
  2. Remove your foot from the traction pedal and ensure that the pedal is in the NEUTRAL position.
  3. Move the throttle lever to the 1/2 throttle position.
  4. Insert the key into the switch and rotate it to the ON/PREHEAT position until the glow-plug indicator light goes out (approximately 7 seconds); then rotate the key to the START position to engage the starter motor.

**Note:** Release the key when the engine starts. The key will move automatically to the ON/RUN position.

**Important:** To prevent overheating of the starter motor, do not engage the starter for longer than 15 seconds. After 10 seconds of continuous cranking, wait 60 seconds before engaging the starter motor again.

5. When the engine is started for the first time or after an overhaul of the engine, operate the machine in forward and reverse for 1 to 2 minutes. Also operate the lift lever and cutting unit drive switch to ensure proper operation of all parts.

Turn the steering wheel to the left and right to check steering response; then shut off the engine and check for oil leaks, loose parts, and any other noticeable malfunctions.

## ⚠ CAUTION

Contact with moving parts could result in injury.

Shut off the engine and wait for all moving parts to stop before checking for oil leaks, loose parts, and other malfunctions.

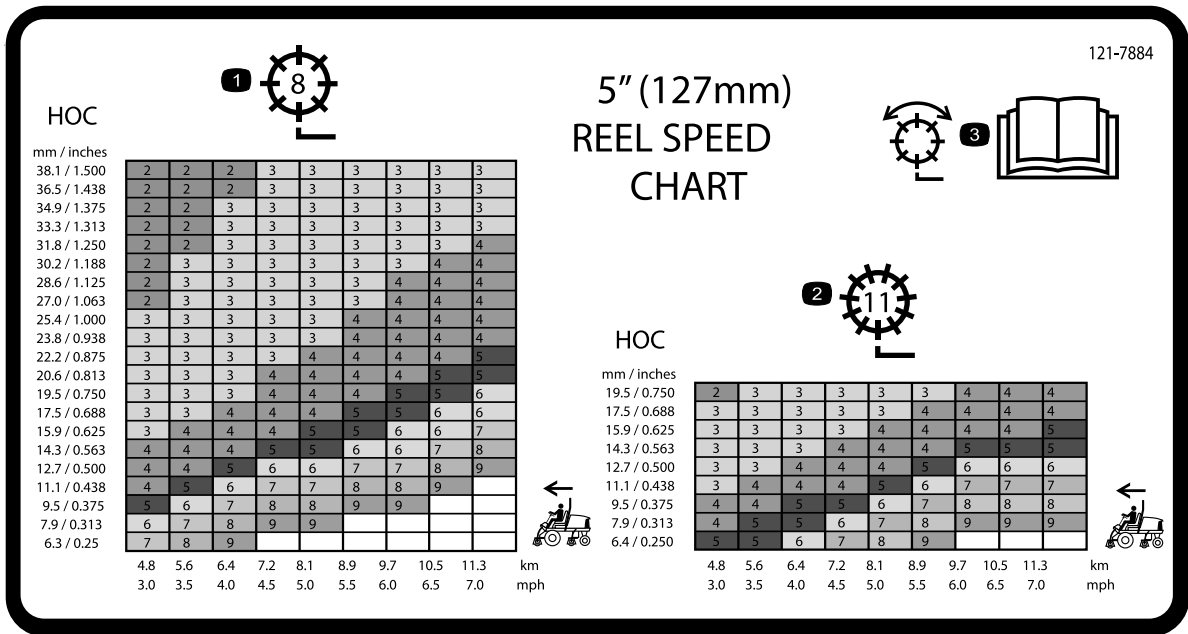
## Shutting Off the Engine

1. Move the throttle control to the IDLE position.
2. Move the cutting unit drive switch to DISENGAGE.
3. Rotate the key to OFF.
4. Remove the key to prevent accidental starting.

## Setting the Reel Speed

To achieve a consistent, high quality of cut and a uniform after-cut appearance, it is important that you set the reel speed controls (located under the seat) correctly. Adjust the reel speed controls as follows:

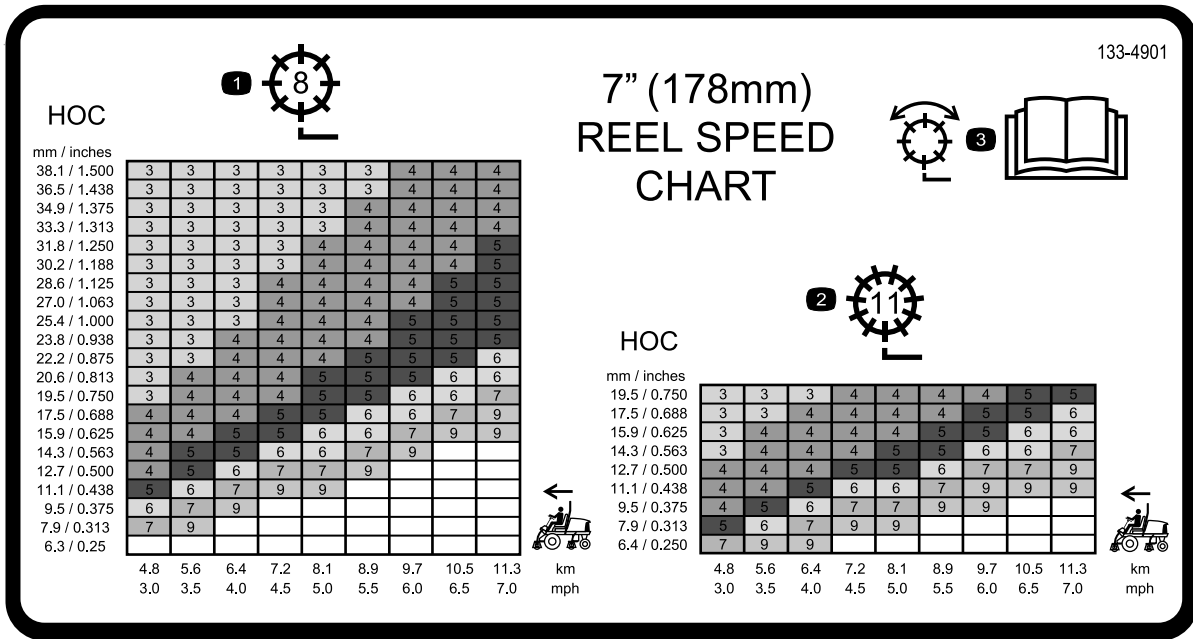
1. Select the height of cut at which the cutting units are set.
2. Choose the desired ground speed best suited for conditions.
3. Use the graph on the reel speed chart decals ([Figure 31](#) and [Figure 32](#)), to determine the proper reel speed setting.



decal121-7884

**Figure 31**  
Model 03820 and 03910

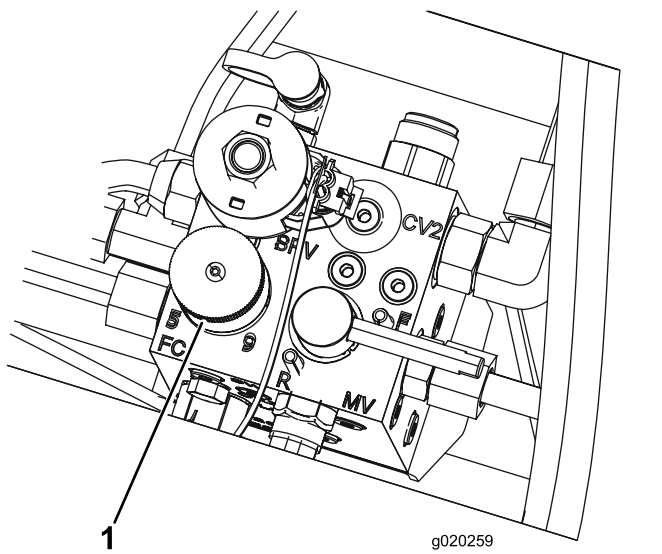
1. 8-blade reel adjustment
2. 11-blade reel adjustment
3. Read the *Operator's Manual* for information on adjusting the reel.



decal133-4901

**Figure 32**  
Model 03821

1. 8-blade reel adjustment
2. 11-blade reel adjustment
3. Read the *Operator's Manual* for information on adjusting the reel.
4. To set the reel speed, rotate the knob ([Figure 33](#)) until the indicator arrow is in line with the number designating the desired setting.



**Figure 33**

1. Reel speed control knob

**Note:** The reel speed can be increased or decreased to compensate for turf conditions. When using baskets, increase the reel speed to improve collection performance.

## Adjusting the Lift-Arm Counterbalance

You can adjust the counterbalance on the lift arms of the rear cutting units to compensate for different turf conditions and to maintain a uniform height of cut in rough conditions or in areas of thatch buildup.

You can adjust each counterbalance spring to 1 of 4 settings. Each increment increases or decreases counterbalance on the cutting unit by 2.3 kg (5 lb). You can position the springs on the back side of the first spring actuator to remove all counterbalance (fourth position).

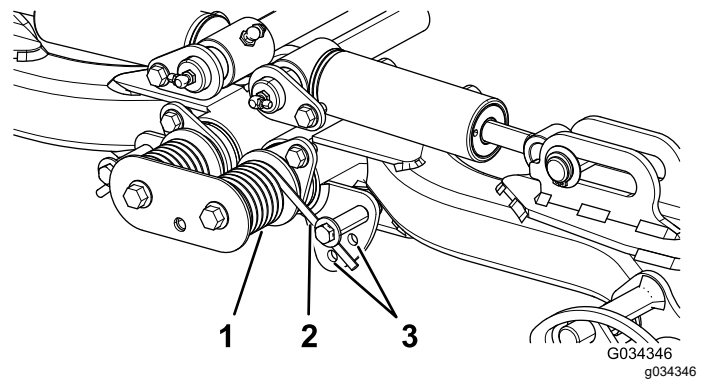
1. Park the machine on a level surface, lower the cutting units, engage the parking brake, shut off the engine, and remove the key from the ignition switch.
2. Insert a tube or similar object onto the long spring end to relieve the spring tension during the adjustment ([Figure 34](#)).

### **CAUTION**

**The springs are under tension and could cause personal injury.**

**Use caution when adjusting them.**

3. While relieving the spring tension, remove the bolt and locknut securing the spring actuator to the bracket ([Figure 34](#)).

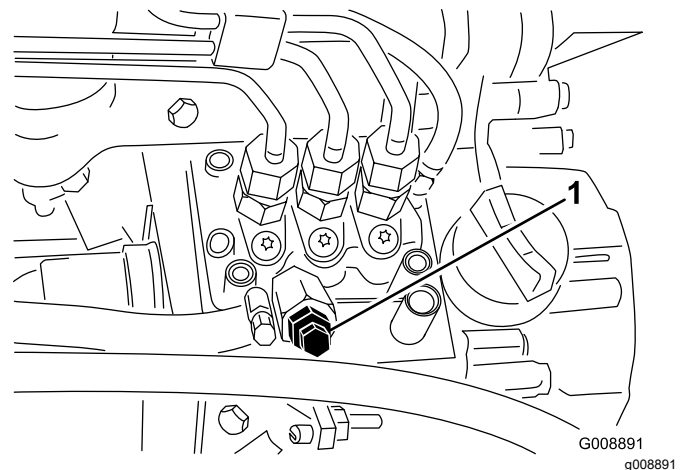


**Figure 34**

1. Spring
  2. Spring actuator
  3. Additional hole locations
- 
4. Move the spring actuator to the desired hole location and secure it with the bolt and the locknut.
  5. Repeat the procedure on the remaining spring.

## Bleeding the Fuel System

1. Park the machine on a level surface, lower the cutting units, engage the parking brake, shut off the engine, and remove the key.
2. Ensure that the fuel tank is at least half full.
3. Unlatch and raise the hood.
4. Open the air-bleed screw on the fuel-injection pump ([Figure 35](#)).



**Figure 35**

1. Fuel-injection pump bleed screw

5. Turn the key in the ignition switch to the ON position. The electric fuel pump will begin operation, thereby forcing air out around the air-bleed screw.

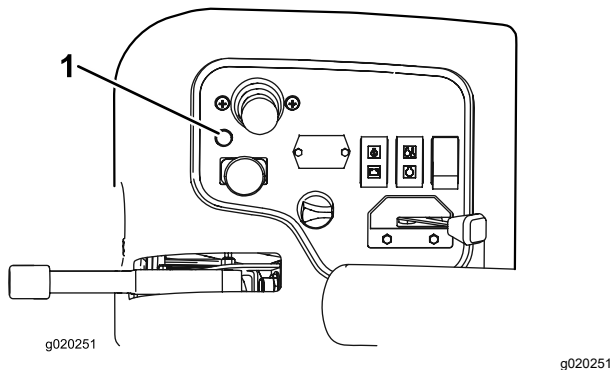
**Note:** Leave the key in the ON position until a solid stream of fuel flows out around the screw.

6. Tighten the screw and turn the ignition key to OFF.

**Note:** Normally the engine should start after the above bleeding procedures are followed. However, if the engine does not start, air may be trapped between the injection pump and injectors; refer to [Bleeding Air from the Injectors \(page 43\)](#).

## Understanding the Diagnostic Light

The machine is equipped with a diagnostic light that indicates if the electronic controller senses an electronic malfunction. The diagnostic light is located on the control panel ([Figure 36](#)). When the electronic controller is functioning correctly and you move the key switch to the ON position, the controller diagnostic light turns on for 3 seconds and turn off to indicate that the light is working properly. If the engine shuts off, then the light turns on steady until the you change key position. The light blinks if the controller detects a malfunction in the electrical system. The light stops blinking and automatically resets when you turn the key switch to the OFF position once the fault has been resolved.



**Figure 36**

1. Diagnostic light

When the controller diagnostic light blinks, 1 of the following problems has been detected by the controller:

- An output has been shorted.
- An output is open circuited.

Using the diagnostic display, determine which output is malfunctioning; refer to [Checking the Interlock Switches \(page 30\)](#).

If the diagnostic light is not illuminated when the key switch is in the ON position, this indicates that the electronic controller is not operating. Possible causes are as follows:

- The loop-back is not connected.
- The light is burned out.

- Fuses are blown.
- It is not functioning correctly.

Check the electrical connections, input fuses, and diagnostic light bulb to determine the malfunction. Ensure that the loop-back connector is secured to the wire harness connector.

## Understanding the Diagnostic ACE Display

The machine is equipped with an electronic controller which controls most machine functions. The controller determines what function is required for various input switches (i.e., seat switch, key switch, etc.) and turns on the outputs to actuate solenoids or relays for the requested machine function.

For the electronic controller to control the machine as desired, each of the input switches, output solenoids, and relays must be connected and functioning properly.

Use the Diagnostic ACE display to help verify and correct electrical functions of the machine.

## Checking the Interlock Switches

**Service Interval:** Before each use or daily

The purpose of the interlock switches is to prevent the engine from cranking or starting unless the traction pedal is in the NEUTRAL position, the Enable/Disable switch is in the DISABLE position, and the Lower Mow/Raise control is in the NEUTRAL position. In addition, the engine should shut off when you press the traction pedal with no one in the seat or if the parking brake is engaged.

### **⚠ CAUTION**

**If safety interlock switches are disconnected or damaged, the machine could operate unexpectedly, causing personal injury.**

- **Do not tamper with the interlock switches.**
- **Check the operation of the interlock switches daily and replace any damaged switches before operating the machine.**

## Verifying the Interlock Switch Function

1. Park the machine on a level surface, lower the cutting units, engage the parking brake, and shut off the engine.

2. Remove the cover from the control panel.
3. Locate the wire harness and loop-back connector (Figure 37).

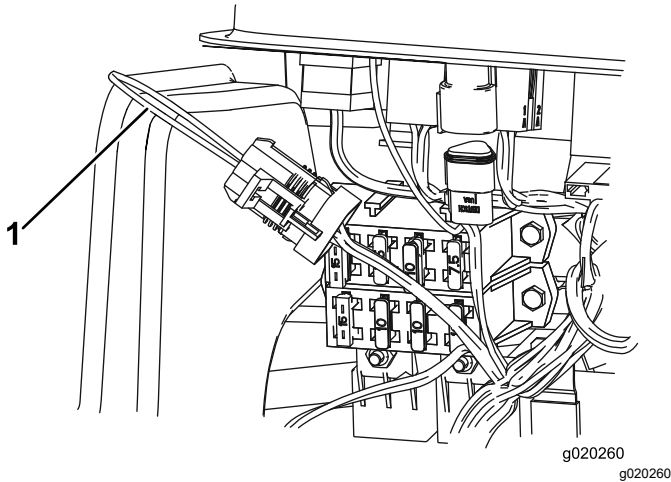


Figure 37

1. Loop-back connector

4. Carefully unplug the loop-back connector from the harness connector.
5. Connect the Diagnostic ACE display connector to the harness connector (Figure 38).

**Note:** Ensure that the correct overlay decal is positioned on the Diagnostic ACE display.

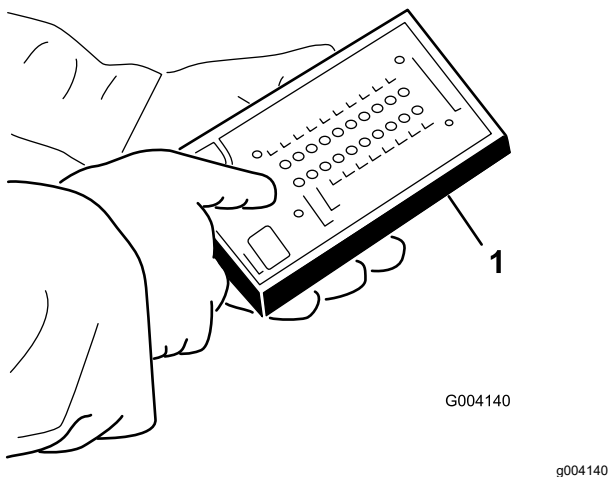


Figure 38

1. Diagnostic ACE

6. Turn the key switch to the ON position, but do not start the machine.

**Note:** The red text on the overlay decal refers to input switches and the green text refers to outputs.

7. The “inputs displayed” LED, on the lower right column of the Diagnostic ACE, should be illuminated. If the “outputs displayed” LED is illuminated, press the toggle button, on

Diagnostic ACE, to change LED to “inputs displayed.”

The Diagnostic ACE illuminates the LED associated with each of the inputs when that input switch is closed.

8. Individually, change each of the switches from open to closed (i.e., sit on the seat, engage the traction pedal, etc.), and note that the appropriate LED on the Diagnostic ACE blinks on and off when the corresponding switch is closed. Repeat this for all switches that you can change by hand.
9. If a switch is closed and the appropriate LED does not turn on, check all wiring and connections to the switch and/or check the switches with an ohm meter or multimeter. Replace any malfunctioning switches and repair any malfunctioning wiring.

**Note:** The Diagnostic ACE also has the ability to detect which output solenoids or relays are turned on. This is a quick way to determine if a machine malfunction is electrical or hydraulic.

## Verifying Output Function

1. Park the machine on a level surface, lower the cutting units, engage the parking brake, shut off the engine, and remove the key.
2. Remove the access panel from the side of the control arm.
3. Locate the wire harness and connectors near the controller.
4. Carefully unplug the loop-back connector from the harness connector.
5. Connect the Diagnostic ACE connector to the harness connector.

**Note:** Make sure that the correct overlay decal is positioned on the Diagnostic ACE.

6. Turn the key switch to the ON position, but do not start the machine.

**Note:** The red text on the overlay decal refers to input switches and the green text refers to outputs.

7. The “outputs displayed” LED, on lower right column of Diagnostic ACE, should be illuminated. If the “inputs displayed” LED is illuminated, press the toggle button, on the Diagnostic ACE, to change the LED to “outputs displayed”.

**Note:** It may be necessary to toggle between “inputs displayed” and “outputs displayed” several times to do the following step. To toggle

back and forth, press the toggle button once. This may be done as often as required. Do not hold the button.

8. Sit on the seat and attempt to operate the desired function of the machine. The appropriate output LEDs should illuminate to indicate that the ECM is turning on that function.

**Note:** If the correct output LEDs do not illuminate, verify that the required input switches are in the necessary positions to allow that function to occur. Verify correct switch function. If the output LEDs are on as specified, but the machine does not function properly, this indicates a non-electrical problem. Repair as necessary.

**Note:** If each output switch is in the correct position and functioning correctly, but the output LEDs are not correctly illuminated, this indicates an ECM problem. If this occurs, contact your authorized Toro distributor for assistance.

**Important:** The Diagnostic ACE display must not be left connected to the machine. It is not designed to withstand the environment of the everyday use of the machine. When you are finished using the Diagnostic ACE, disconnect it from the machine and connect the loop-back connector to the harness connector. The machine does not operate without the loop-back connector installed on the harness. Store the Diagnostic ACE in a dry, secure location in the shop, not on the machine.

## Operating Tips

### Becoming Familiar with the Machine

Before mowing grass, practice operating the machine in an open area. Start and shut off the engine. Operate in forward and reverse. Lower and raise the cutting units and engage and disengage the cutting units. When you feel familiar with the machine, practice operating up and down slopes at different speeds.

### Understanding the Warning System

If a warning light comes on during operation, stop the machine immediately and correct the problem before continuing operation. Serious damage could occur if you operate the machine with a malfunction.

### Mowing Grass

Start the engine and move the throttle to the FAST position. Move the Enable/Disable switch to the ENABLE position and use the Lower Mow/Raise lever to control the cutting units (the front cutting units are timed to lower before the rear cutting units). To move forward and cut grass, press the traction pedal forward.

### Driving the Machine in Transport Mode

Move the Enable/Disable switch to the DISABLE position and raise the cutting units to the transport position. Move the Mow/Transport lever to the TRANSPORT position. Be careful when driving between objects so that you do not accidentally damage the machine or the cutting units. Use extra care when operating the machine on slopes. Drive slowly and avoid sharp turns on slopes to prevent rollovers.



# After Operation

## After Operation Safety

### General Safety

- Shut off the engine, remove the key, and wait for all movement to stop before you leave the operator's position. Allow the machine to cool before adjusting, servicing, cleaning, or storing it.
- Clean grass and debris from the cutting units, drives, mufflers, cooling screens, and engine compartment to help prevent fires. Clean up oil or fuel spills.
- Disengage the drive to the attachment whenever you are hauling or not using the machine.
- Maintain and clean the seat belt(s) as necessary.
- Do not store the machine or fuel container where there is an open flame, spark, or pilot light, such as on a water heater or on other appliances.

## Pushing or Towing the Machine

In an emergency, you can move the machine by actuating the bypass valve in the variable displacement hydraulic pump and installing a hydraulic hose to bypass the check valve, and then pushing or towing the machine.

**Important:** Do not push or tow the machine faster than 3 to 4.8 km/h (2 to 3 mph) or for more than 0.4 km (1/4 mile), because internal transmission damage may occur. The bypass valve must be open whenever you push or tow the machine. Additionally, you need to install a hydraulic hose to bypass the check valve whenever you push or tow the machine in reverse.

If you need to push or tow your machine, you will likely need to move it both forward and in reverse. To ensure that the drive system does not become damaged from pushing or towing, it is best to prepare the machine for both forward and reverse pushing or towing.

## Preparing the Machine for Pushing or Towing in Reverse

**Important:** If you need to push or tow the machine in reverse, you must first bypass the check valve in the 4-wheel-drive manifold.

The following Toro parts are needed to bypass the check valve:

- Toro Part No. 59-7410, diagnostic fitting

- Toro Part No. 354-79, diagnostic-fitting cap
- Toro Part No. 95-8843, hydraulic hose
- Toro Part No. 95-0985, coupler fitting (2)
- Toro Part No. 340-77, hydraulic fitting (2)

1. Install a diagnostic fitting in the unmarked port located between ports M8 and P2 on the rear traction manifold (Figure 39).

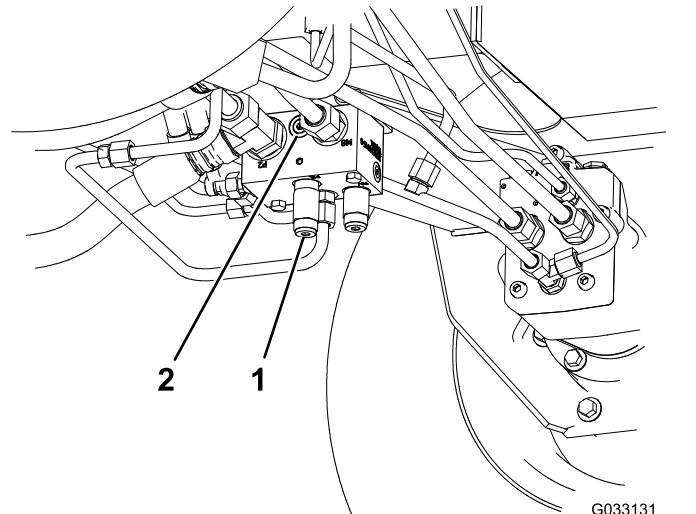


Figure 39

1. Rear traction manifold
2. Unmarked port (behind front left wheel)

2. Connect a hydraulic hose between the diagnostic fitting installed in the rear traction manifold and the reverse traction pressure test port (Figure 40).

**Note:** Use the hydraulic fittings and coupler fittings as needed to install the hose.

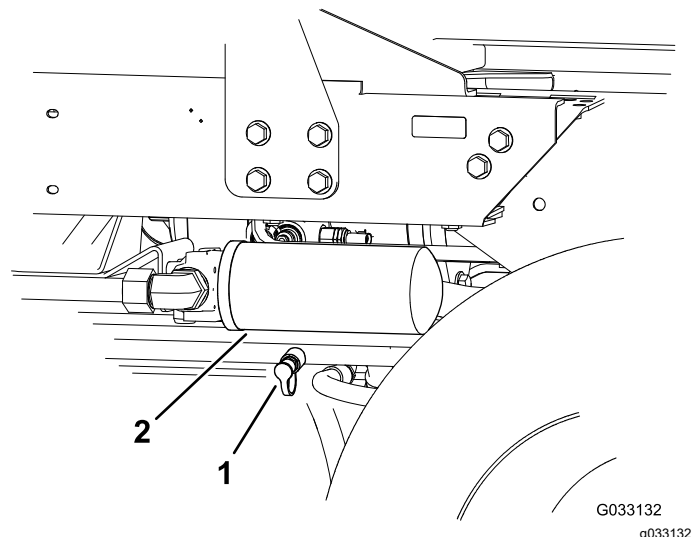


Figure 40

1. Reverse traction pressure
2. Hydraulic fluid return filter test port

3. Rotate the bypass valve 90° (1/4 turn) in either direction to open it and allow fluid to bypass internally (Figure 41).

**Note:** Because the fluid bypasses the transmission, you can move the machine slowly without damaging the transmission.

Note the position of the valve when opening and closing it.

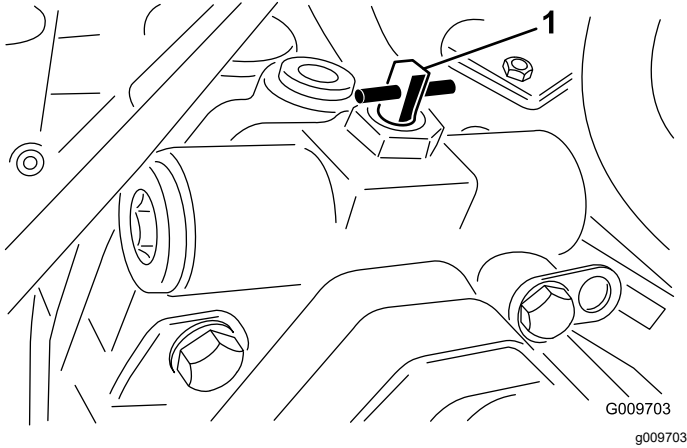


Figure 41

1. Bypass valve

4. When you are finished pushing or towing the machine, remove the hydraulic hose that you installed.
5. Install the existing cap onto the reverse traction pressure test port.
6. Install the diagnostic-fitting cap onto the fitting that you installed on the manifold.
7. Rotate the bypass valve 90° (1/4 turn) back before starting the engine.

**Note:** Do not exceed 7 to 11 N·m (5 to 8 ft·lb) torque to close the valve.

forward slowly without damaging the transmission.

Note the position of the valve when opening and closing it.

3. Rotate the bypass valve 90° (1/4 turn) back before starting the engine.

**Note:** Do not exceed 7 to 11 N·m (5 to 8 ft·lb) torque to close the valve.

## Hauling the Machine

- Use full-width ramps for loading the machine onto a trailer or truck.
- Tie the machine down securely.

## Identifying the Tie-Down Points

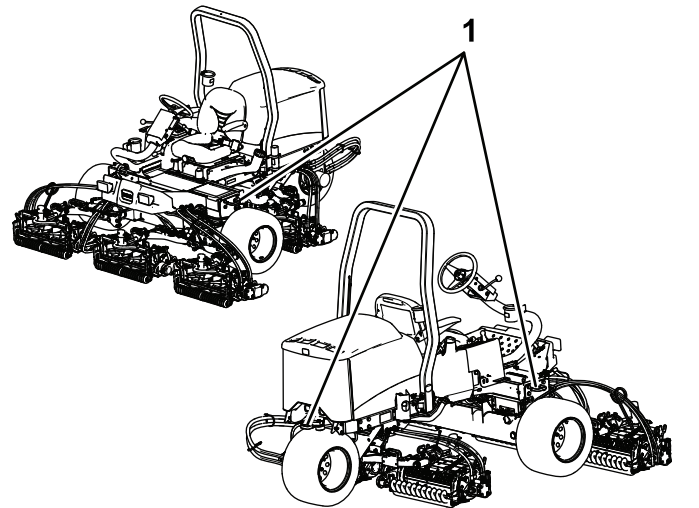


Figure 42

1. Tie-down loops

## Pushing or Towing the Machine Forward Only

If you need to push or tow the machine forward only, you can just rotate the bypass valve.

**Important:** If you need to push or tow the machine in reverse, refer to [Preparing the Machine for Pushing or Towing in Reverse \(page 33\)](#).

1. Open the hood and remove the center shroud.
2. Rotate the bypass valve 90° (1/4 turn) in either direction to open it and allow fluid to bypass internally (Figure 41).

**Note:** Because the fluid bypasses the transmission, you can move the machine

# Maintenance

**Note:** Determine the left and right sides of the machine from the normal operating position.

**Note:** Download a free copy of the electrical or hydraulic schematic by visiting [www.Toro.com](http://www.Toro.com) and searching for your machine from the Manuals link on the home page.

**Important:** Refer to your engine owner's manual and cutting unit *Operator's Manual* for additional maintenance procedures.

## Maintenance Safety

- Before you leave the operator's position, do the following:
  - Park the machine on a level surface.
  - Disengage the cutting unit(s) and lower the attachments.
  - Engage the parking brake.
  - Shut off the engine and remove the key.
  - Wait for all movement to stop.
- Allow machine components to cool before performing maintenance.
- If possible, do not perform maintenance while the engine is running. Keep away from moving parts.
- Support the machine with jack stands whenever you work under the machine.
- Carefully release pressure from components with stored energy.
- Keep all parts of the machine in good working condition and all hardware tightened.
- Replace all worn or damaged decals.
- To ensure safe, optimal performance of the machine, use only genuine Toro replacement parts. Replacement parts made by other manufacturers could be dangerous, and such use could void the product warranty.

## Recommended Maintenance Schedule(s)

Maintenance Service Interval	Maintenance Procedure
After the first hour	<ul style="list-style-type: none"> <li>• Torque the wheel nuts.</li> </ul>
After the first 10 hours	<ul style="list-style-type: none"> <li>• Torque the wheel nuts.</li> <li>• Check the condition and tension of all belts.</li> </ul>
After the first 50 hours	<ul style="list-style-type: none"> <li>• Change the oil and oil filter.</li> </ul>
Before each use or daily	<ul style="list-style-type: none"> <li>• Inspect the seat belt(s) for wear, cuts, and other damage. Replace the seat belt(s) if any component does not operate properly.</li> <li>• Check the parking brake.</li> <li>• Check the interlock system.</li> <li>• Check the engine-oil level.</li> <li>• Drain the water separator.</li> <li>• Check the tire pressure.</li> <li>• Check the engine-coolant level.</li> <li>• Clean debris off of the radiator.</li> <li>• Check the hydraulic lines and hoses.</li> <li>• Check the level of the hydraulic fluid.</li> <li>• Check the reel-to-bedknife contact.</li> </ul>
Every 25 hours	<ul style="list-style-type: none"> <li>• Check the electrolyte level (if machine is in storage, check every 30 days).</li> </ul>
Every 50 hours	<ul style="list-style-type: none"> <li>• Lubricate all bearings and bushings (daily when conditions are dusty and dirty).</li> </ul>
Every 100 hours	<ul style="list-style-type: none"> <li>• Check the condition and tension of all belts.</li> </ul>
Every 150 hours	<ul style="list-style-type: none"> <li>• Change the oil and oil filter.</li> </ul>
Every 200 hours	<ul style="list-style-type: none"> <li>• Service the air cleaner (more frequently in extremely dusty or dirty conditions).</li> <li>• Torque the wheel nuts.</li> <li>• Check the adjustment of the parking brake.</li> </ul>

<b>Maintenance Service Interval</b>	<b>Maintenance Procedure</b>
Every 400 hours	<ul style="list-style-type: none"> <li>• Check the fuel lines and connections.</li> <li>• Replace the fuel filter canister.</li> <li>• Service the parking brakes.</li> </ul>
Every 800 hours	<ul style="list-style-type: none"> <li>• If you are not using the recommended hydraulic fluid or have ever filled the reservoir with an alternative fluid, change the hydraulic fluid.</li> <li>• If you are not using the recommended hydraulic fluid or have ever filled the reservoir with an alternative fluid, replace the hydraulic filter.</li> </ul>
Every 1,000 hours	<ul style="list-style-type: none"> <li>• If you are using the recommended hydraulic fluid, replace the hydraulic filter.</li> </ul>
Every 2,000 hours	<ul style="list-style-type: none"> <li>• If you are using the recommended hydraulic fluid, change the hydraulic fluid.</li> </ul>
Every 2 years	<ul style="list-style-type: none"> <li>• Drain and clean the fuel tank.</li> </ul>

# Daily Maintenance Checklist

Duplicate this page for routine use.

Maintenance Check Item	For the week of:						
	Mon.	Tues.	Wed.	Thurs.	Fri.	Sat.	Sun.
Check the safety interlock operation.							
Check the brake operation.							
Check the engine-oil level.							
Check the cooling system fluid level.							
Drain the water/fuel separator.							
Check the air filter, dust cup, and burp valve.							
Check for unusual engine noises. <sup>1</sup>							
Check the radiator for debris.							
Check for unusual operating noises.							
Check the hydraulic system fluid level.							
Check the hydraulic hoses for damage.							
Check for fluid leaks.							
Check the fuel level.							
Check the tire pressure.							
Check the instrument operation.							
Check the height-of-cut adjustment.							
Lubricate all the grease fittings. <sup>2</sup>							
Touch-up any damaged paint.							
Wash the machine.							
<sup>1</sup> Check the glow plug and injector nozzles if starting is hard, there is excess smoke, or rough running is noted. <sup>2</sup> Immediately <b>after every</b> washing, regardless of the interval listed.							

## Notation for Areas of Concern

Inspection performed by:		
Item	Date	Information
1		
2		
3		
4		
5		

# Pre-Maintenance Procedures

## Removing the Hood

1. Unlatch and raise the hood.
2. Remove the hairpin cotter securing the hood pivot to the mounting brackets ([Figure 43](#)).

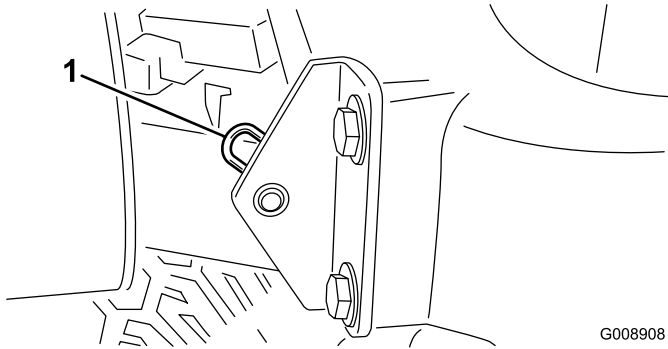


Figure 43

G008908  
g008908

1. Hairpin cotter

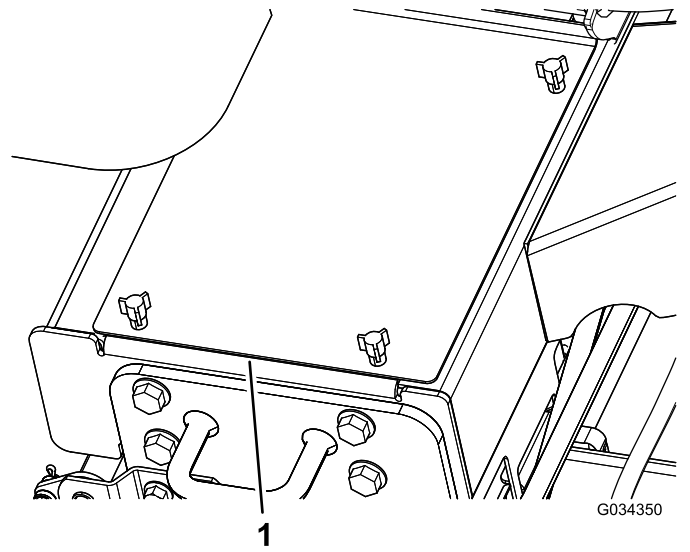


Figure 44

1. Battery cover

3. Slide the hood to the right side, lift the other side, and pull it out of the brackets.

**Note:** Reverse the procedure to install the hood.

## Removing the Battery Cover

Loosen the knobs and remove the battery cover ([Figure 44](#)).

**Note:** Refer to [Servicing the Battery \(page 44\)](#) for more information.

# Lubrication

## Greasing the Bearings and Bushings

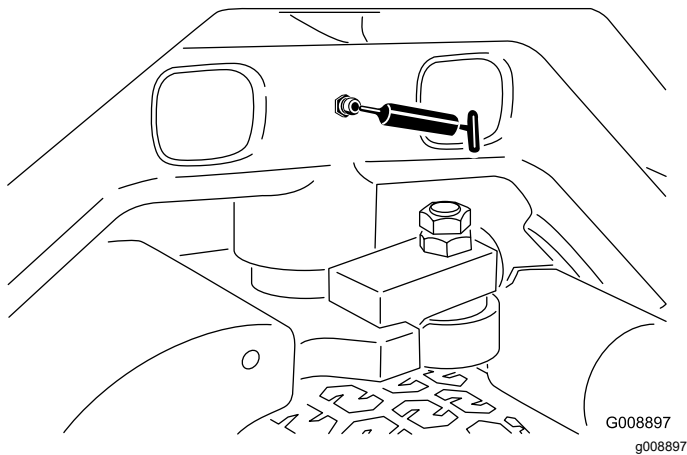
**Service Interval:** Every 50 hours (daily when conditions are dusty and dirty).

Park the machine on a level surface, lower the cutting units, engage the parking brake, shut off the engine, and remove the key from the ignition switch.

Lubricate the grease fittings regularly with No. 2 lithium grease. Lubricate the bearings and bushings daily when operating conditions are extremely dusty and dirty. Dusty and dirty operating conditions could cause dirt to get into the bearings and bushings, resulting in accelerated wear. Lubricate the grease fittings immediately after every washing, regardless of the interval specified.

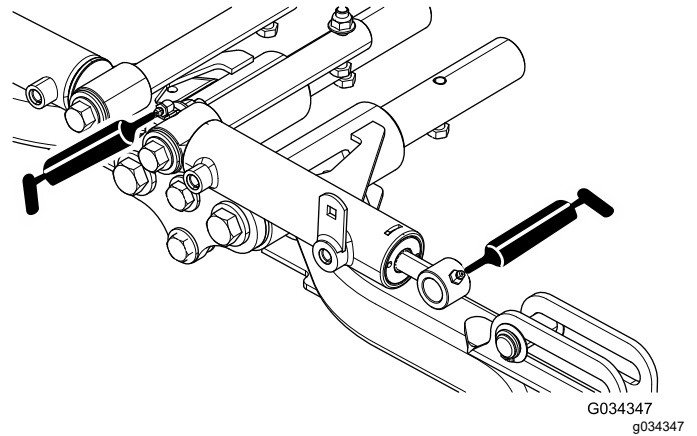
The grease fitting locations and quantities are as follows:

- Steering pivot ([Figure 45](#))



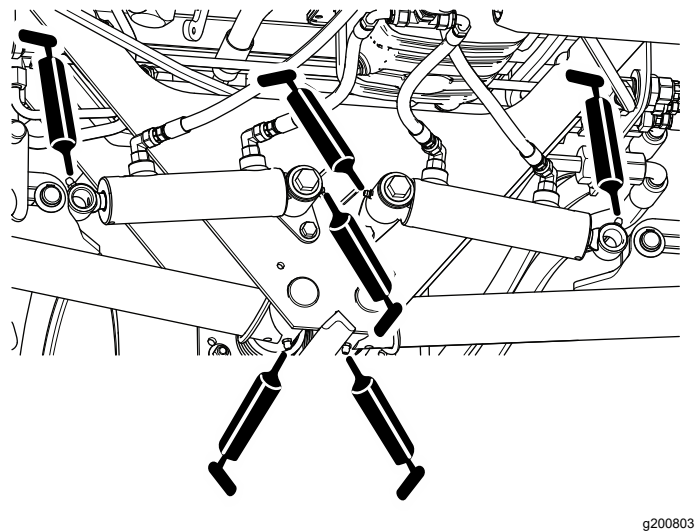
**Figure 45**

- Front lift-arm pivots and lift cylinders (3 each); refer to [Figure 46](#).



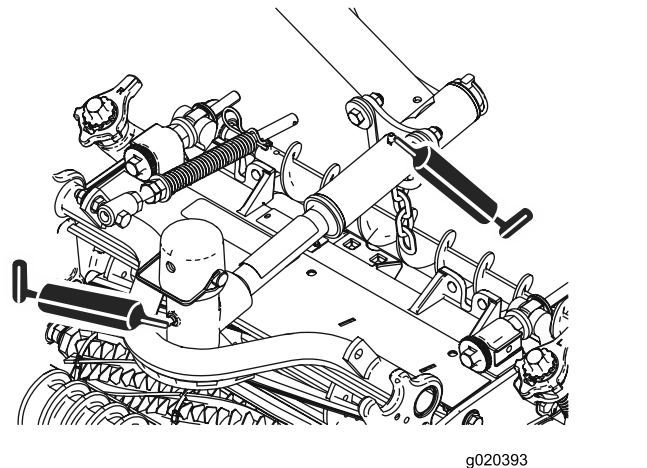
**Figure 46**

- Rear lift-arm pivots and lift cylinders (3 each side); refer to [Figure 47](#).



**Figure 47**

- Cutting unit pivots (2 each); refer to [Figure 48](#).



**Figure 48**

- Neutral adjust mechanism ([Figure 49](#))

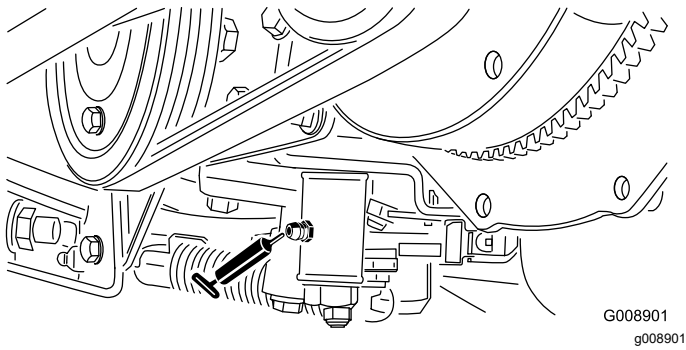


Figure 49

- Mow/transport slide (Figure 50)

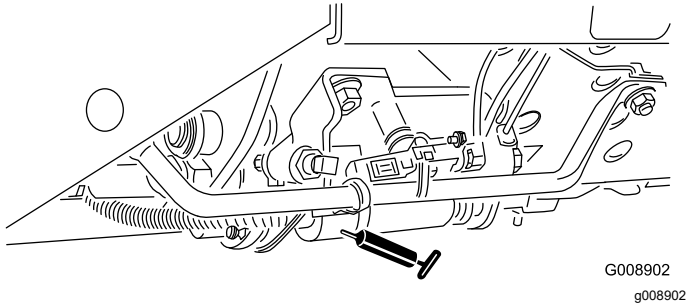


Figure 50

- Belt tension pivot (Figure 51)

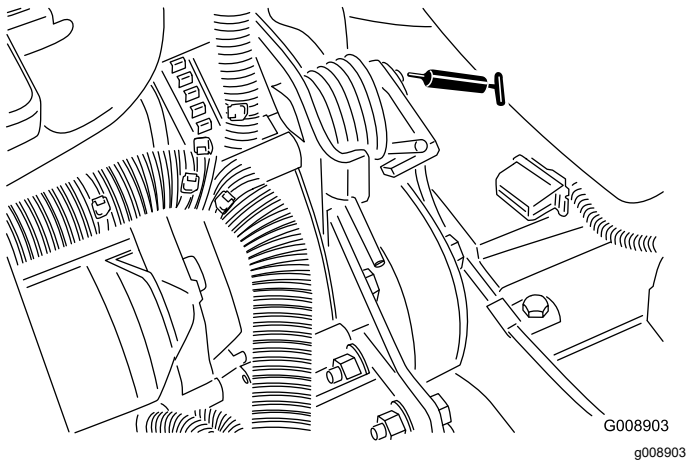


Figure 51

# Engine Maintenance

## Engine Safety

- Shut off the engine before checking the oil or adding oil to the crankcase.
- Do not change the governor speed or overspeed the engine.

## Checking the Engine-Oil Level

**Service Interval:** Before each use or daily

The engine is shipped with oil in the crankcase; however, the oil level must be checked before and after the engine is first started.

Crankcase capacity is approximately 3.8 L (4 US qt) with the filter.

Use high-quality engine oil that meets the following specifications:

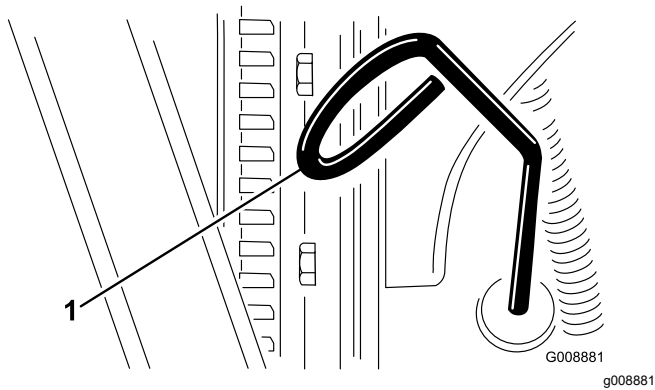
- API Classification Level Required: CH-4, CI-4 or higher.
- Preferred oil: SAE 15W-40 (above 0°F (-17°C))
- Alternate oil: SAE 10W-30 or 5W-30 (all temperatures)

**Note:** Toro Premium Engine Oil is available from your distributor in either 15W-40 or 10W-30 viscosity.

**Note:** The best time to check the engine oil is when the engine is cool before it has been started for the day. If it has already been run, allow the oil to drain back down to the sump for at least 10 minutes before checking. If the oil level is at or below the Add mark on the dipstick, add oil to bring the oil level to the Full mark. Do not overfill the engine. If the oil level is between the Full and Add marks, no oil addition is required.

1. Park the machine on a level surface, lower the cutting units, engage the parking brake, shut off the engine, and remove the key.
2. Remove the dipstick (Figure 52) and wipe it with a clean rag.

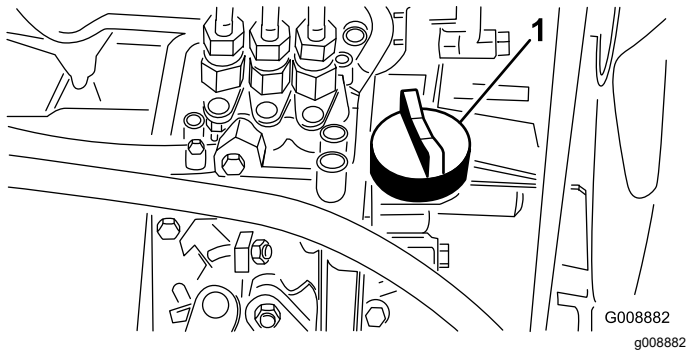




**Figure 52**

1. Dipstick

3. Push the dipstick down into the dipstick tube and make sure that it is seated fully. Pull the dipstick out and check the oil level.
4. If the oil level is low, remove the oil-fill cap (Figure 53) and gradually add small quantities of oil, checking the level frequently, until the level reaches the Full mark on the dipstick.



**Figure 53**

1. Oil-fill cap

5. Install the oil-fill cap and close the hood.

## Servicing the Air Cleaner

**Service Interval:** Every 200 hours (more frequently in extremely dusty or dirty conditions).

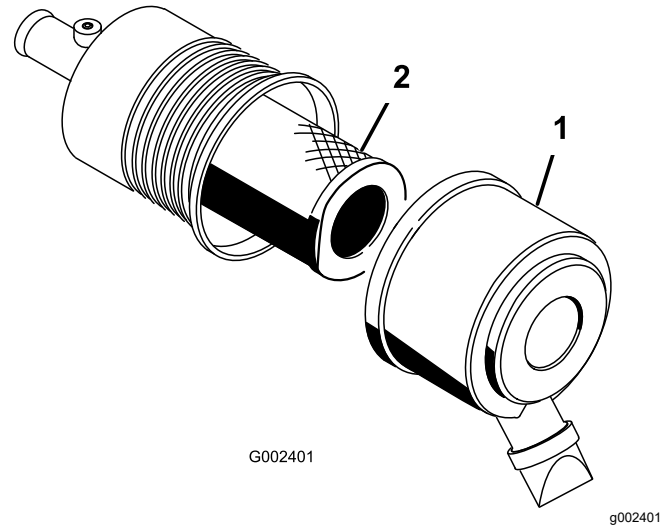
- Check the air-cleaner body for damage which could cause an air leak. Replace it if it is damaged. Check the whole intake system for leaks, damage, or loose hose clamps.
- Service the air cleaner at the recommended service interval or earlier if engine performance suffers due to extremely dusty, dirty conditions. Changing the air filter before it is necessary only increases the chance of dirt entering the engine when you remove the filter.
- Be sure that the cover is seated correctly and seals with the air-cleaner body.

1. Park the machine on a level surface, lower the cutting units, engage the parking brake, shut off the engine, and remove the key.
2. Release the latches securing the air-cleaner cover to the air-cleaner body (Figure 54).
3. Remove the cover from the air-cleaner body (Figure 54).
4. Before removing the filter, use low-pressure air (276 kPa [40 psi], clean and dry) to help remove large accumulations of debris packed between outside of primary filter and the canister.

**Note:** Avoid using high-pressure air, which could force dirt through the filter into the intake tract. This cleaning process prevents debris from migrating into the intake when you remove the primary filter.

5. Remove and replace the filter (Figure 54).

Do not clean the used element because it could damage the filter media.



**Figure 54**

1. Air-cleaner cover
2. Filter

6. Inspect the new filter for shipping damage, checking the sealing end of the filter and the body.

**Important:** Do not use a damaged element.

7. Insert the new filter by applying pressure to the outer rim of the element to seat it in the canister.

**Important:** Do not apply pressure to the flexible center of the filter.

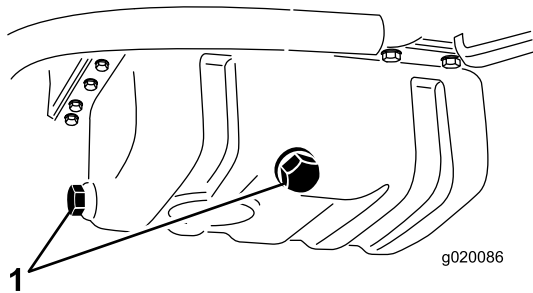
8. Clean the dirt-ejection port located in the removable cover.
9. Remove the rubber outlet valve from the cover, clean the cavity and replace the outlet valve.

10. Install the cover orienting the rubber outlet valve in a downward position—between approximately 5 o'clock to 7 o'clock when viewed from the end.
11. Secure the cover latches.

## Changing the Engine Oil and Filter

**Service Interval:** After the first 50 hours  
Every 150 hours

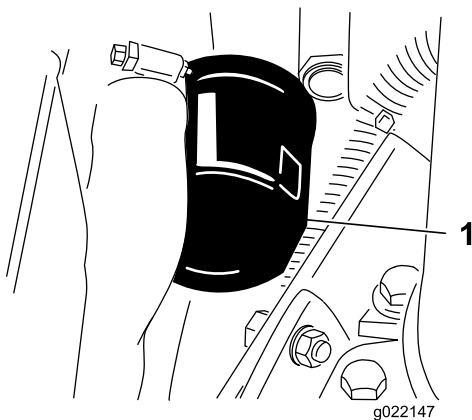
1. Park the machine on a level surface, lower the cutting units, engage the parking brake, shut off the engine, and remove the key.
2. Remove either drain plug ([Figure 55](#)) and let the oil flow into a drain pan. When the oil stops flowing, install the drain plug.



**Figure 55**

1. Engine-oil drain plugs

3. Remove the oil filter ([Figure 56](#)).



**Figure 56**

1. Engine oil filter

4. Apply a light coat of clean oil to the new filter seal, and install the filter.

**Important:** Do not overtighten the filter.

5. Add oil to the crankcase; refer to [Checking the Engine-Oil Level](#) (page 40).

## Fuel System Maintenance

### Servicing the Fuel Tank

**Service Interval:** Every 2 years—Drain and clean the fuel tank.

Park the machine on a level surface, lower the cutting units, engage the parking brake, shut off the engine, and remove the key.

Drain and clean the tank if the fuel system becomes contaminated or if the machine will be stored for an extended period of time. Use clean fuel to flush out the tank.

### Inspecting the Fuel Lines and Connections

**Service Interval:** Every 400 hours/Yearly (whichever comes first)

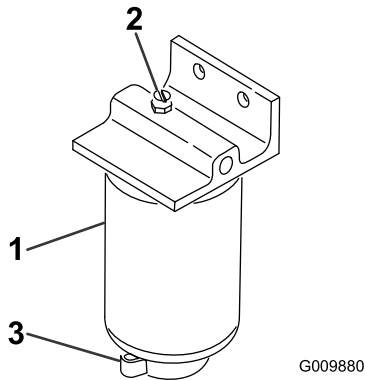
Park the machine on a level surface, lower the cutting units, engage the parking brake, shut off the engine, and remove the key from the ignition switch.

Inspect the fuel lines and connections for deterioration, damage, or loose connections.

# Draining the Water Separator

**Service Interval:** Before each use or daily

1. Park the machine on a level surface, lower the cutting units, engage the parking brake, shut off the engine, and remove the key from the ignition switch.
2. Place a clean container under the fuel filter.
3. Loosen the drain valve on the bottom of the filter canister ([Figure 57](#)).



**Figure 57**

1. Water separator/filter canister
2. Vent plug
3. Drain valve

4. Tighten the valve after draining.

# Changing the Fuel Filter Canister

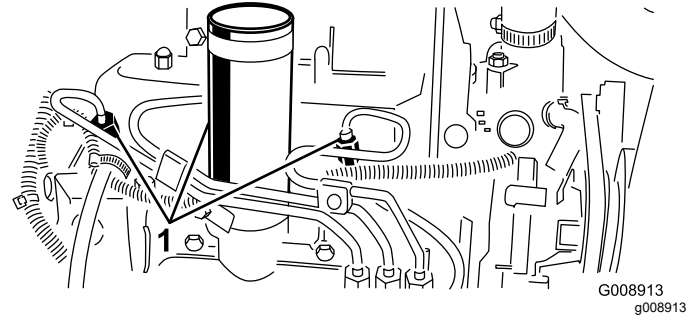
**Service Interval:** Every 400 hours

1. Park the machine on a level surface, lower the cutting units, engage the parking brake, shut off the engine, and remove the key from the ignition switch.
2. Clean the area where the filter canister mounts ([Figure 57](#)).
3. Remove the filter canister and clean the mounting surface.
4. Lubricate the gasket on the filter canister with clean oil.
5. Install the filter canister by hand until the gasket contacts the mounting surface; then rotate it an additional 1/2 turn.

# Bleeding Air from the Injectors

**Note:** Use this procedure only if the fuel system has been purged of air through normal priming procedures and the engine does not start; refer to [Bleeding the Fuel System](#) (page 29).

1. Park the machine on a level surface, lower the cutting units, engage the parking brake, and shut off the engine.
2. Loosen the pipe connection to the No. 1 nozzle and holder assembly.



**Figure 58**

1. Fuel injectors

3. Move the throttle to the FAST position.
4. Turn the key in the key switch to the START position and watch the fuel flow around the connector. Turn the key to the OFF position when there is a continuous flow.
5. Tighten the pipe connector securely.
6. Repeat the procedure on the remaining nozzles.

# Electrical System Maintenance

## Electrical System Safety

- Disconnect the battery before repairing the machine. Disconnect the negative terminal first and the positive last. Connect the positive terminal first and the negative last.
- Charge the battery in an open, well-ventilated area, away from sparks and flames. Unplug the charger before connecting or disconnecting the battery. Wear protective clothing and use insulated tools.

## Servicing the Battery

**Service Interval:** Every 25 hours—Check the electrolyte level (if machine is in storage, check every 30 days).

Park the machine on a level surface, lower the cutting units, engage the parking brake, shut off the engine, and remove the key from the ignition switch.

Maintain the battery electrolyte level and keep the top of the battery clean. Store the machine where the temperature is cooler rather than warmer to prevent the battery from discharging more rapidly.

Maintain the cell level with distilled or demineralized water. Do not fill the cells above the bottom of the split ring inside each cell. Install the filler caps with the vents pointing to the rear (toward the fuel tank).

### **⚠ DANGER**

**Battery electrolyte contains sulfuric acid which is fatal if consumed and causes severe burns.**

- **Do not drink electrolyte and avoid contact with skin, eyes, or clothing. Wear eye protection to shield your eyes and rubber gloves to protect your hands.**
- **Fill the battery where clean water is always available for flushing the skin.**

Keep the top of the battery clean by washing it periodically with a brush dipped in ammonia or bicarbonate of soda solution. Flush the top surface with water after cleaning. Do not remove the filler caps while cleaning.

The battery cables must be tight on the terminals to provide good electrical contact.

### **⚠ WARNING**

**Incorrect battery cable routing could damage the tractor and cables causing sparks. Sparks can cause the battery gasses to explode, resulting in personal injury.**

- **Always disconnect the negative (black) battery cable before disconnecting the positive (red) cable.**
- **Always connect the positive (red) battery cable before connecting the negative (black) cable.**

If corrosion occurs at the terminals, disconnect the cables, negative (–) cable first, and scrape the clamps and terminals separately. Connect the cables, positive (+) cable first, and coat the terminals with petroleum jelly.

## Checking the Fuses

The fuses in the electrical system are located under the control panel.

# Drive System Maintenance

## Checking the Tire Pressure

**Service Interval:** Before each use or daily

The tires are over-inflated for shipping. Therefore, release some of the air to reduce the pressure. The correct air pressure in the tires is 83 kPa (12 psi).

**Note:** Maintain the recommended pressure in all tires to ensure a good quality of cut and proper machine performance.

### **▲ DANGER**

Low tire pressure decreases machine side hill stability. This could cause a rollover, which may result in personal injury or death.

Do not under-inflate the tires.

## Torquing the Wheel Nuts

**Service Interval:** After the first hour

After the first 10 hours

Every 200 hours

Torque the wheel nuts to 103 to 127 N·m (76 to 94 ft-lb).

### **▲ WARNING**

Failure to maintain proper torque of the wheel nuts could result in personal injury.

Maintain proper torque of the wheel nuts.

## Adjusting the Traction Drive for Neutral

If the machine moves when the traction pedal is in the NEUTRAL position, adjust the traction cam.

1. Park the machine on a level surface, lower the cutting units, engage the parking brake, shut off the engine, and remove the key from the ignition switch.
2. Raise a front wheel and a rear wheel off the floor and place support blocks under the frame.

### **▲ WARNING**

If the machine is not supported adequately, it may accidentally fall, injuring anyone under the machine.

A front wheel *and* a rear wheel must be raised off the ground; otherwise, the machine will move during adjustment.

3. Loosen the locknut on the traction adjustment cam (Figure 59).

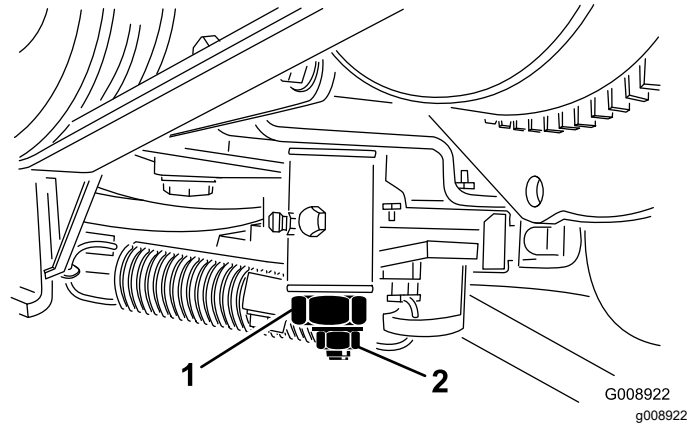


Figure 59

1. Traction adjustment cam
2. Locknut

### **▲ WARNING**

The engine must be running so that you can make a final adjustment of the traction adjustment cam. Contact with hot or moving parts can result in personal injury.

Keep your hands, feet, face, and other body parts away from the muffler, other hot parts of the engine, and rotating parts.

4. Start the engine and rotate the cam hex in both directions to determine the mid position of the neutral span.
5. Tighten the locknut securing the adjustment.
6. Shut off the engine.
7. Remove the support blocks and lower the machine to the shop floor. Test drive the machine to ensure that it does not move when the traction pedal is in neutral.

# Cooling System Maintenance

## Cooling System Safety

- Swallowing engine coolant can cause poisoning; keep out of reach from children and pets.
- Discharge of hot, pressurized coolant or touching a hot radiator and surrounding parts can cause severe burns.
  - Always allow the engine to cool at least 15 minutes before removing the radiator cap.
  - Use a rag when opening the radiator cap, and open the cap slowly to allow steam to escape.

## Checking the Cooling System

**Service Interval:** Before each use or daily

Clean debris off the radiator daily (Figure 60). Clean the radiator hourly if conditions are extremely dusty and dirty; refer to [Cleaning the Engine Cooling System](#) (page 47).

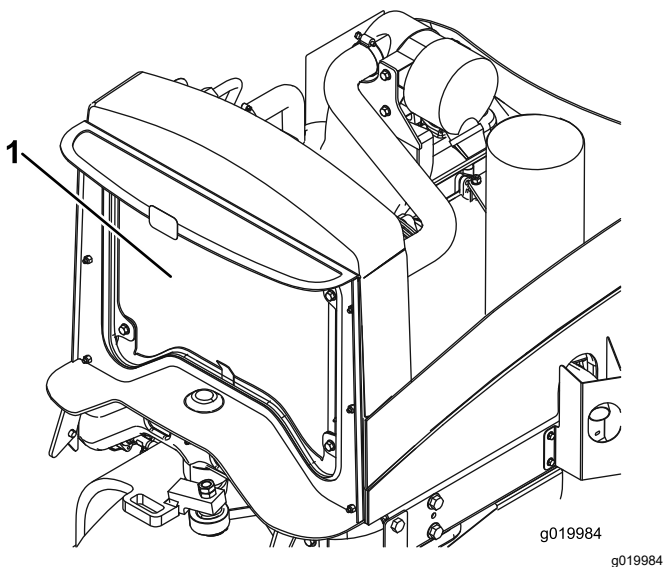


Figure 60

1. Radiator

The cooling system is filled with a 50/50 solution of water and permanent ethylene glycol antifreeze. Check the coolant level at the beginning of each day before starting the engine.

The capacity of the cooling system is approximately 5.7 L (6 US qt).

## ⚠ CAUTION

If the engine has been running, the pressurized, hot coolant can escape and cause burns.

- Do not open the radiator cap when the engine is running.
  - Use a rag when opening the radiator cap, and open the cap slowly to allow steam to escape.
1. Park the machine on a level surface, lower the cutting units, engage the parking brake, shut off the engine, and remove the key.
  2. Check the coolant level in the expansion tank (Figure 61). With a cold engine, the coolant level should be approximately midway between the marks on the side of the tank.
  3. If the coolant level is low, remove the expansion-tank cap and replenish the system. **Do not overfill the tank.**
  4. Install the expansion-tank cap.

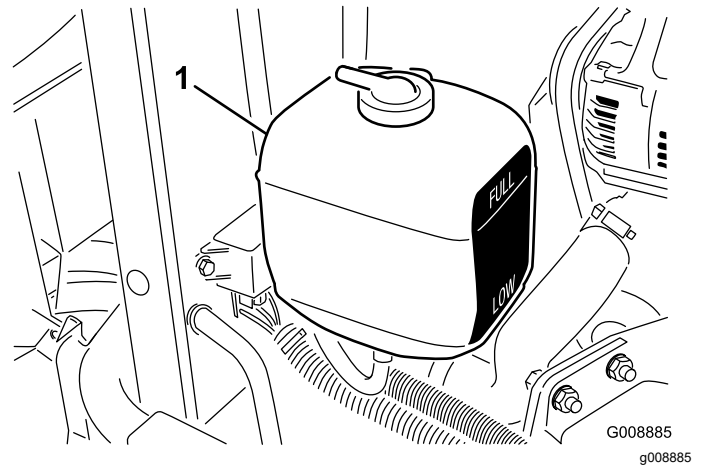


Figure 61

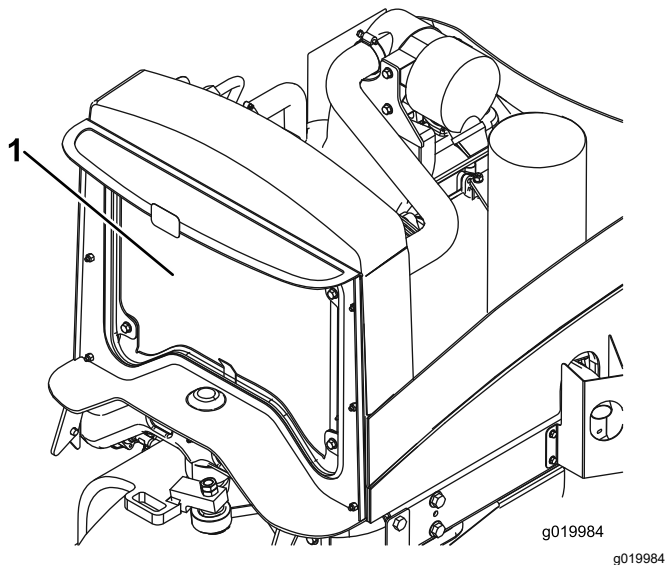
1. Expansion tank

# Cleaning the Engine Cooling System

**Service Interval:** Before each use or daily

Remove debris from the radiator daily. Clean it more frequently in dirty conditions.

1. Park the machine on a level surface, lower the cutting units, engage the parking brake, shut off the engine, and remove the key from the ignition switch.
2. Raise the hood.
3. Clean the engine area thoroughly of all debris.
4. Clean both sides of the radiator thoroughly with compressed air (Figure 62).



**Figure 62**

1. Radiator

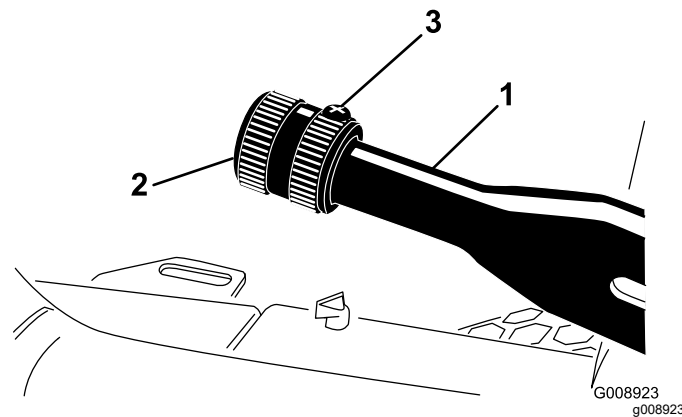
5. Close the hood.

# Brake Maintenance

## Adjusting the Parking Brake

**Service Interval:** Every 200 hours—Check the adjustment of the parking brake.

1. Park the machine on a level surface, lower the cutting units, engage the parking brake, shut off the engine, and remove the key from the ignition switch.
2. Loosen the setscrew securing the knob to the parking-brake lever (Figure 63).



**Figure 63**

1. Parking-brake lever
2. Knob
3. Set screw

3. Rotate the knob until a force of 133 to 178 N (30 to 40 lb) is required to actuate the lever.
4. Tighten the setscrew after the adjustment has been attained.

## Servicing the Parking Brakes

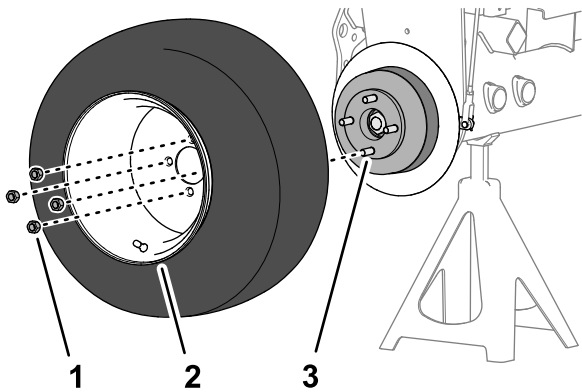
**Service Interval:** Every 400 hours

### Preparing the Machine

1. Park machine on a level surface, engage parking brake, lower cutting units, shut off the engine, remove the key, and wait for all moving parts to stop before leaving the operator's seat.
2. Raise the front of machine.
3. Support the machine with jack stands rated for the weight of your machine; refer to [Specifications \(page 23\)](#).
4. Repeat steps 2 and 3 at the other side of the machine.

## Removing the Front Wheels

1. Remove the 4 lug nuts that secure the front wheel to the hub, and remove the wheel ([Figure 64](#)).



**Figure 64**

g332518

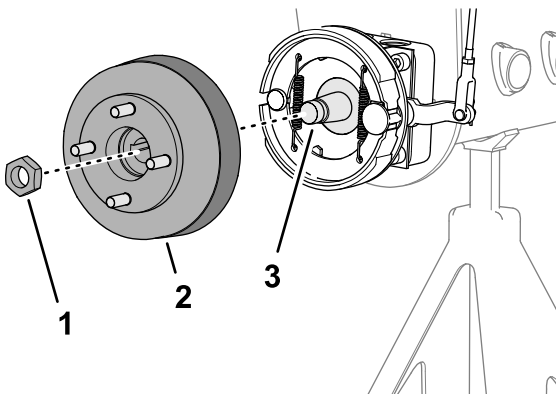
1. Lug nut
2. Wheel
3. Hub

2. Repeat step 1 at the other side of the machine.

## Removing the Wheel Hub and Brake Drum

**Special Tools:** Wheel Hub Puller—Toro Part No. TOR4097

1. Remove the locknut that secures the hub to the wheel-motor shaft ([Figure 65](#) or [Figure 66](#)).

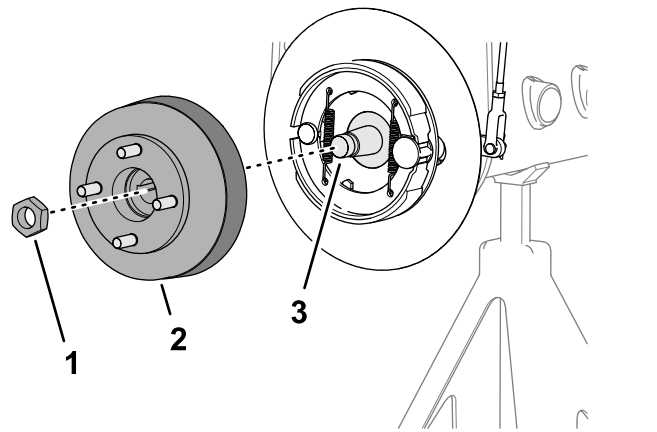


**Figure 65**

g332519

Machines without the Optional Grass Shield

1. Locknut
2. Hub and brake drum
3. Wheel-motor shaft



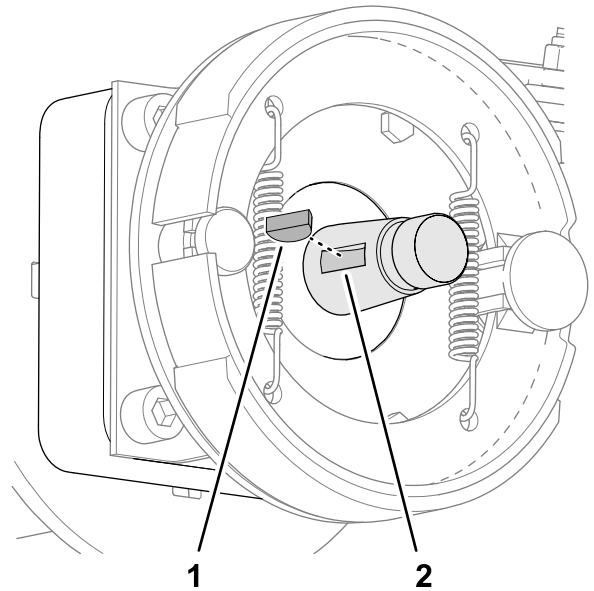
**Figure 66**

Machines with the Optional Grass Shield

g332520

1. Locknut
2. Hub and brake drum
3. Wheel-motor shaft

2. Repeat step 1 at the other side of the machine.
3. Release the parking brake.
4. Use the specified wheel hub puller to remove wheel hub and brake drum from the wheel-motor shaft ([Figure 65](#) or [Figure 66](#)).
5. Remove woodruff key from the wheel-motor shaft ([Figure 67](#)).



**Figure 67**

g332521

1. Woodruff key
2. Groove (wheel-motor shaft)

6. Repeat steps 4 and 5 at the other side of the machine.



## Cleaning the Brake Drum and Shoes

At both sides of the machine, clean inside the brake drums, the brake shoes, backing plate (Figure 68), and when installed, the optional grass shield of any grass, dirt, and dust.

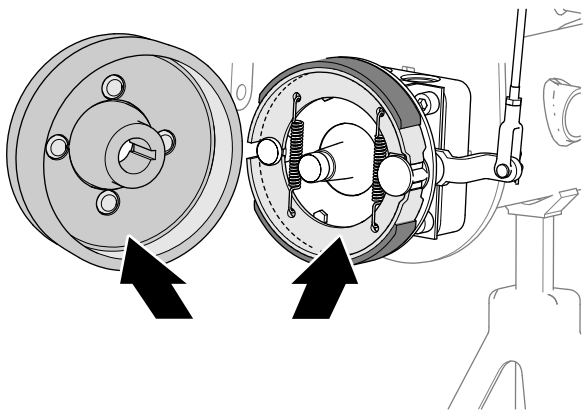


Figure 68

g332543

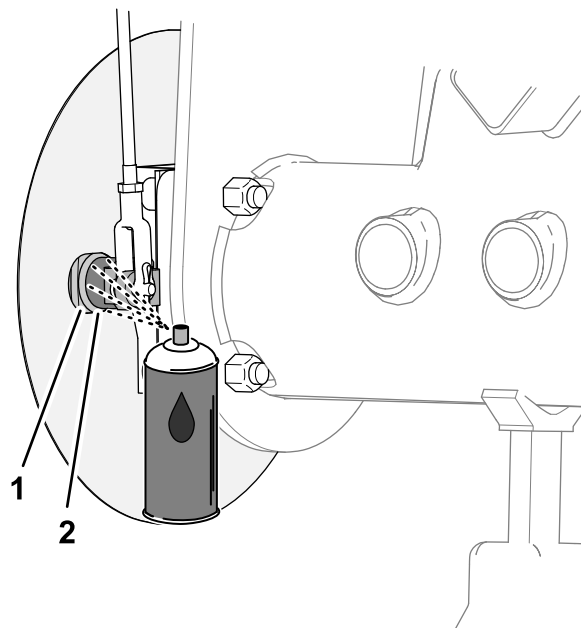


Figure 70

Machines with the Optional Grass Shield

g332545

1. Backing plate
2. Brake cam shaft

## Inspecting and Lubricating the Brake Cam Shaft

1. At the inboard side of the brake-backing plate (machines without the optional wheel-rim grass shield) or the wheel shield (machines with the optional wheel-rim grass shield), spray penetrating oil between the brake cam shaft and the backing plate (Figure 69 or Figure 70).

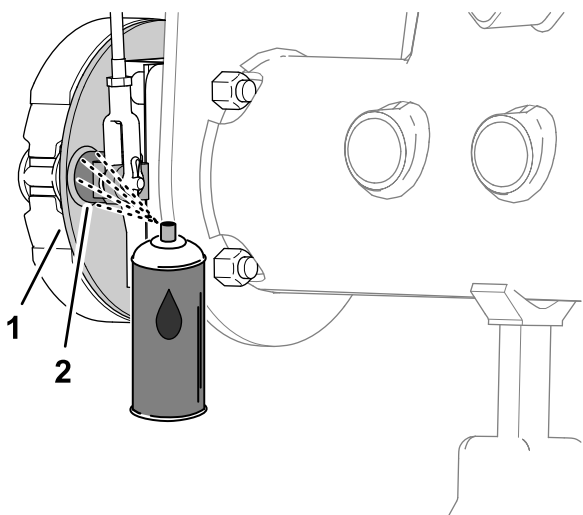


Figure 69

Machines without the Optional Grass Shield

g332544

1. Backing plate
2. Brake cam shaft

2. Move the parking brake lever up and down to check that the lever for the brake-cam lever moves freely (Figure 71).

**Note:** If the brake cam binds, repair or replace the brake cam; refer to the *Service Manual* for your machine.

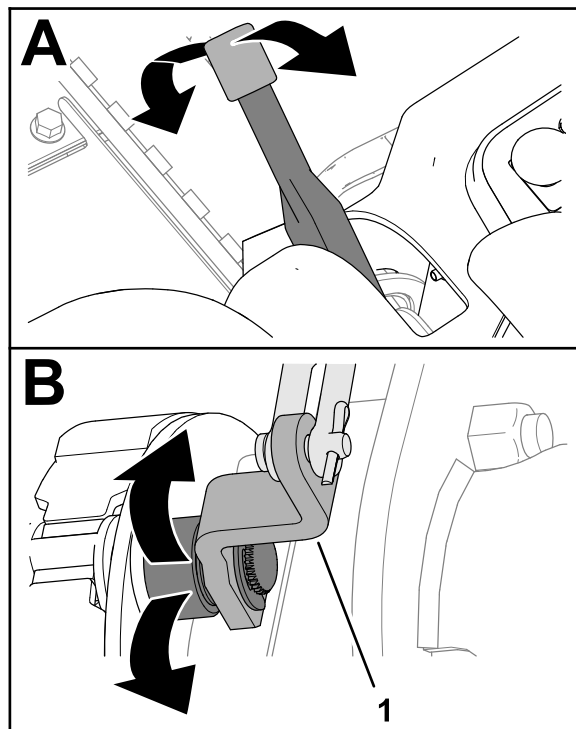


Figure 71

g332560

1. Brake-cam lever

3. Repeat steps 1 and 2 at the other side of the machine.
4. Move the parking brake lever down (the disengaged position).

## Inspecting the Brake Linkage

1. Inspect the left and right brake-rod assemblies (Figure 72) for damage and wear.

**Note:** If the brake rod parts are damaged and worn, replace them; refer to the *Service Manual* for your machine.

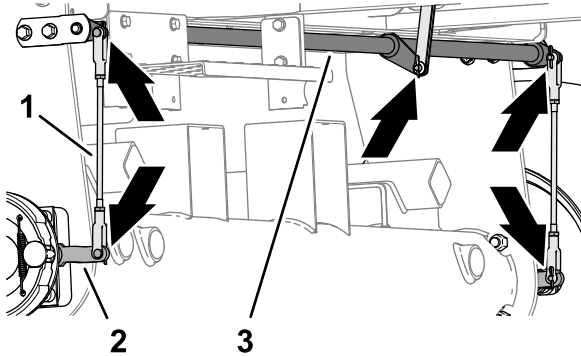


Figure 72

g332541

1. Brake-rod assemblies
2. Brake-cam lever
3. Brake pivot shaft

2. Inspect the brake pivot shaft (Figure 72) for damage and wear.

If the pivot shaft is damaged and worn, replace them; refer to the *Service Manual* for your machine.

## Installing the Wheel Hub and Brake Drum

1. Thoroughly clean the wheel hub and hydraulic motor shaft.
2. Insert the woodruff key into the groove of the wheel-motor shaft (Figure 73).

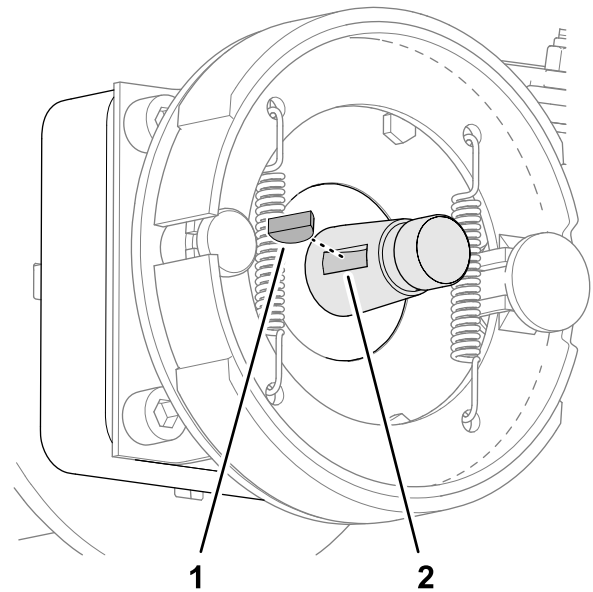


Figure 73

g332521

1. Woodruff key
2. Groove (wheel-motor shaft)

3. Assemble the wheel hub and brake drum onto the wheel-motor shaft (Figure 74 or Figure 75).

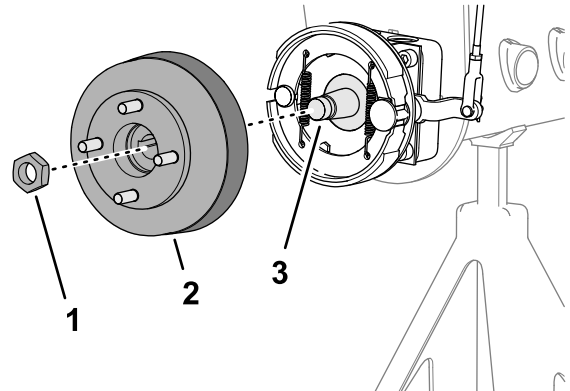
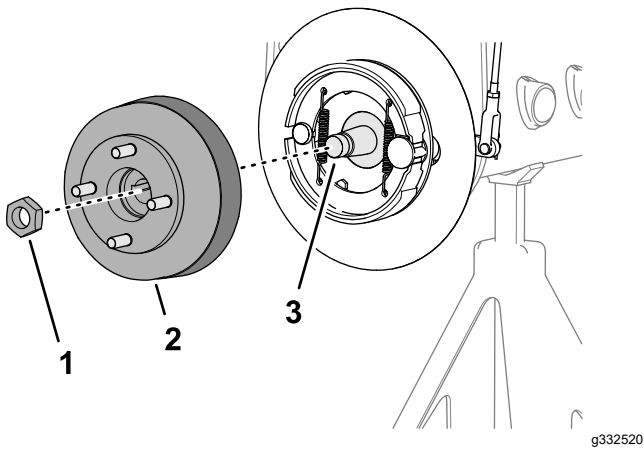


Figure 74

g332519

Machines without the Optional Grass Shield

1. Locknut
2. Hub and brake drum
3. Wheel-motor shaft



**Figure 75**

Machines with the Optional Grass Shield

1. Locknut
2. Hub and brake drum
3. Wheel-motor shaft

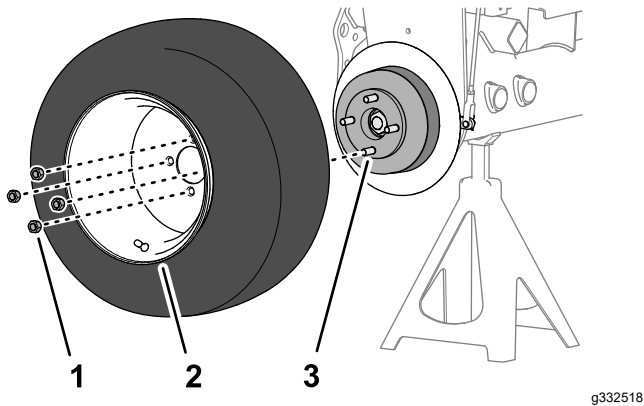
4. Secure the wheel hub to the shaft with the locknut (Figure 74 or Figure 75), and tighten by hand.

**Note:** The brake shoes and backing plate must concentrically align with the brake drum. If the shoes, plate, and drum are misaligned, refer to the *Service Manual* for your machine.

5. Repeat steps 1 through 4 at the other side of the machine.

## Installing the Wheel

1. Assemble the wheel to the hub with the 4 lug nuts (Figure 76), and tighten the lug nuts by hand.



**Figure 76**

1. Lug nut
2. Wheel
3. Hub

2. Repeat step 1 at the other side of the machine.
3. Remove the jack stands and lower the machine.
4. Torque wheel lug nuts to 95 to 122·Nm (70 to 90 ft-lb) in a crossing pattern.

5. Torque the locknut is to 339 to 372 N·m (250 to 275 ft-lb).
6. Check parking brake and adjust it if necessary; refer to [Checking the Parking Brake \(page 24\)](#).

# Belt Maintenance

## Servicing the Engine Belts

**Service Interval:** After the first 10 hours—Check the condition and tension of all belts.

Every 100 hours—Check the condition and tension of all belts.

### Tensioning the Alternator/Fan Belt

1. Park the machine on a level surface, lower the cutting units, engage the parking brake, shut off the engine, and remove the key from the ignition switch.
2. Open the hood.
3. Check the belt tension by pressing the belt midway between the alternator and crankshaft pulleys.

**Note:** With 98 N (22 lb) of force, the belt should deflect 11 mm (7/16 inch).

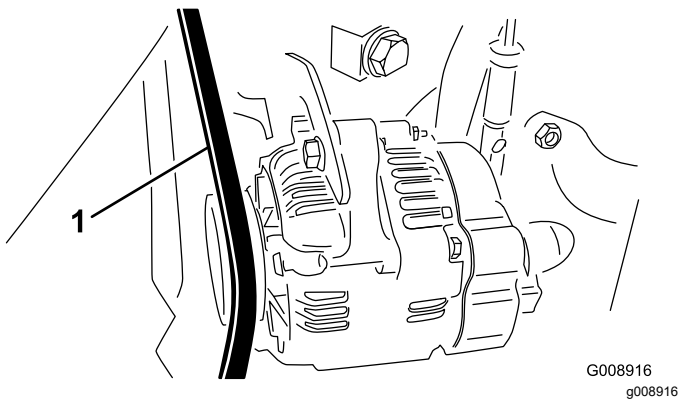


Figure 77

1. Alternator/fan belt

4. If the deflection is incorrect, complete the following procedure to tension the belt:
  - A. Loosen the bolt securing the brace to the engine and the bolt securing the alternator to the brace.
  - B. Insert a pry bar between the alternator and engine and pry the alternator outward.
  - C. When the proper tension is achieved, tighten the alternator and brace bolts to secure the adjustment.

### Replacing the Hydrostat Drive Belt

1. Park the machine on a level surface, lower the cutting units, engage the parking brake, shut off

the engine, and remove the key from the ignition switch.

2. Insert a nut driver or small piece of tubing onto the end of the belt tensioning spring.

#### **▲ WARNING**

**The spring is under a heavy load and could cause personal injury**

**Use caution when de-tensioning the spring.**

3. Push down and forward on the spring end (Figure 78) to unhook it from the bracket and release tension on the spring.

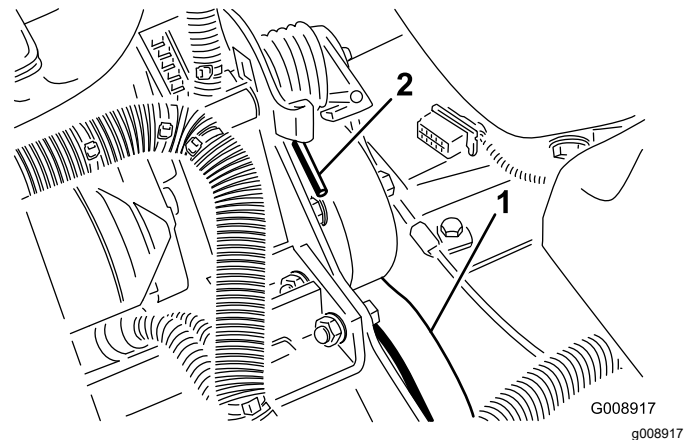


Figure 78

1. Hydrostat drive belt
2. Spring end

4. Replace the belt.
5. Reverse the procedure to tension the spring.

# Controls System Maintenance

## Adjusting the Throttle

1. Park the machine on a level surface, lower the cutting units, engage the parking brake, shut off the engine, and remove the key from the ignition switch.
2. Position the throttle lever rearward so that it stops against the control panel slot.
3. Loosen the throttle cable connector on the injection pump lever arm (Figure 79).

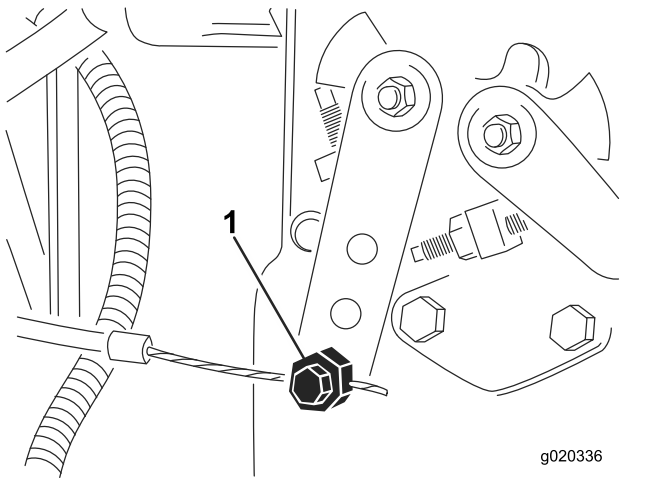


Figure 79

1. Injection pump lever arm
4. Hold the injection pump lever arm against the low idle stop and tighten the cable connector.
5. Loosen the screws securing the throttle control to the control panel.
6. Push the throttle control lever all of the way forward.
7. Slide the stop plate until it contacts the throttle lever and tighten the screws securing the throttle control to the control panel.
8. If the throttle does not stay in position during operation, torque the locknut, used to set the friction device on the throttle lever, to 5 to 6 N·m (44 to 53 in-lb).

**Note:** The maximum force required to operate the throttle lever should be 89 N (20 lb).

# Hydraulic System Maintenance

## Hydraulic System Safety

- Seek immediate medical attention if fluid is injected into skin. Injected fluid must be surgically removed within a few hours by a doctor.
- Ensure that all hydraulic-fluid hoses and lines are in good condition and all hydraulic connections and fittings are tight before applying pressure to the hydraulic system.
- Keep your body and hands away from pinhole leaks or nozzles that eject high-pressure hydraulic fluid.
- Use cardboard or paper to find hydraulic leaks.
- Safely relieve all pressure in the hydraulic system before performing any work on the hydraulic system.

## Checking the Hydraulic Lines and Hoses

**Service Interval:** Before each use or daily

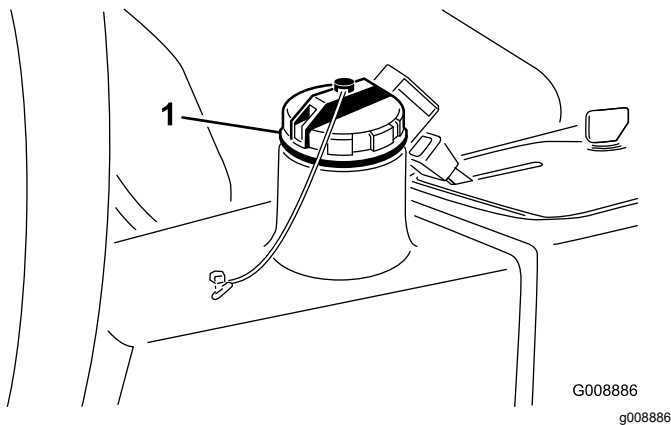
Check the hydraulic lines and hoses for leaks, kinked lines, loose mounting supports, wear, loose fittings, weather deterioration, and chemical deterioration. Make all necessary repairs before operating.

## Checking the Hydraulic Fluid

**Service Interval:** Before each use or daily—Check the level of the hydraulic fluid.

The reservoir is filled at the factory with high-quality hydraulic fluid. The best time to check the hydraulic oil is when the fluid is cold. The machine should be in its transport configuration.

1. Park the machine on a level surface, lower the cutting units, engage the parking brake, shut off the engine, and remove the key.
2. Clean the area around the filler neck and cap of the hydraulic tank (Figure 80).



**Figure 80**

1. Hydraulic-tank cap

3. Remove the cap.
4. Remove the dipstick from the filler neck and wipe it with a clean rag. Insert the dipstick into the filler neck; then remove it and check the fluid level. The fluid level should be within 6 mm (1/4 inch) of the mark on the dipstick.
5. If the level is low, add the appropriate fluid to raise the level to the full mark.
6. Install the dipstick and cap onto the filler neck.

## Hydraulic Fluid Specifications

The reservoir is filled at the factory with high-quality hydraulic fluid. Check the level of the hydraulic fluid before you first start the engine and daily thereafter; refer to [Checking the Hydraulic Fluid \(page 53\)](#).

**Recommended hydraulic fluid:** Toro PX Extended Life Hydraulic Fluid; available in 19 L (5 US gallon) pails or 208 L (55 US gallon) drums.

**Note:** A machine using the recommended replacement fluid requires less frequent fluid and filter changes.

**Alternative hydraulic fluids:** If Toro PX Extended Life Hydraulic Fluid is not available, you may use another conventional, petroleum-based hydraulic fluid having specifications that fall within the listed range for all the following material properties and that it meets industry standards. Do not use synthetic fluid. Consult with your lubricant distributor to identify a satisfactory product.

**Note:** Toro does not assume responsibility for damage caused by improper substitutions, so use products only from reputable manufacturers who will stand behind their recommendation.

### High Viscosity Index/Low Pour Point Anti-wear Hydraulic Fluid, ISO VG 46

Material Properties:

Viscosity, ASTM D445 cSt @ 40°C (104°F)  
44 to 48

Viscosity Index ASTM D2270 140 or higher

Pour Point, ASTM D97 -37°C to -45°C (-34°F  
to -49°F)

Industry Specifications: Eaton Vickers 694 (I-286-S,  
M-2950-S/35VQ25 or  
M-2952-S)

**Note:** Many hydraulic fluids are almost colorless, making it difficult to spot leaks. A red dye additive for the hydraulic fluid is available in 20 ml (0.67 fl oz) bottles. A bottle is sufficient for 15 to 22 L (4 to 6 US gallons) of hydraulic fluid. Order Part No. 44-2500 from your authorized Toro distributor.

**Important:** Toro Premium Synthetic Biodegradable Hydraulic Fluid is the only synthetic biodegradable fluid approved by Toro. This fluid is compatible with the elastomers used in Toro hydraulic systems and is suitable for a wide-range of temperature conditions. This fluid is compatible with conventional mineral oils, but for maximum biodegradability and performance, the hydraulic system should be thoroughly flushed of conventional fluid. The oil is available in 19 L (5 US gallon) pails or 208 L (55 US gallon) drums from your authorized Toro distributor.

## Hydraulic Fluid Capacity

22.7 L (6 US gallons); refer to [Hydraulic Fluid Specifications \(page 54\)](#)

## Changing the Hydraulic Fluid

**Service Interval:** Every 2,000 hours—**If you are using the recommended hydraulic fluid**, change the hydraulic fluid.

Every 800 hours—**If you are not using the recommended hydraulic fluid or have ever filled the reservoir with an alternative fluid**, change the hydraulic fluid.

### **⚠ WARNING**

**Hot hydraulic fluid can cause severe burns.**

**Allow the hydraulic fluid to cool before performing any maintenance to the hydraulic system.**

If the fluid becomes contaminated, contact your local Toro distributor because the system must be flushed. Contaminated fluid looks milky or black when compared to clean oil.

1. Park the machine on a level surface, lower the cutting units, engage the parking brake, shut off the engine, and remove the key from the ignition switch.
2. Disconnect the large hydraulic hose (Figure 81) from the reservoir and let the hydraulic fluid flow into a drain pan.

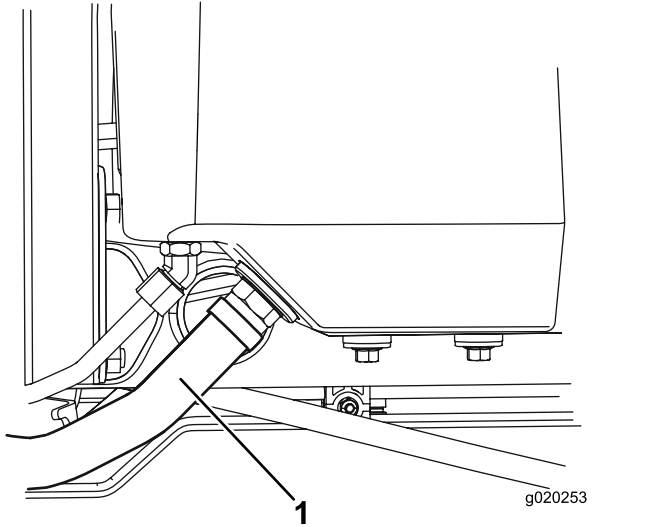


Figure 81

1. Hydraulic hose

3. Install the hydraulic hose when hydraulic fluid stops draining.
4. Fill the reservoir (Figure 82) with approximately 22.7 L (6 US gallons) of hydraulic fluid; refer to [Hydraulic Fluid Specifications \(page 54\)](#).

**Important:** Use only the hydraulic fluids specified. Other fluids could cause system damage.

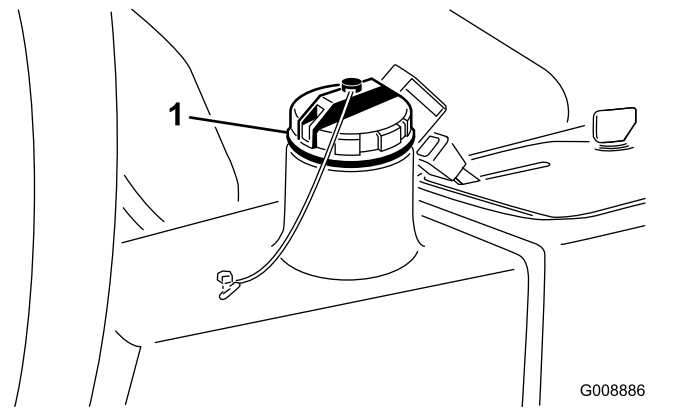


Figure 82

1. Hydraulic fill cap

5. Install the reservoir cap. Start the engine and use all of the hydraulic controls to distribute the hydraulic fluid throughout the system.
6. Check for leaks; then shut off the engine.
7. Check the fluid level and add enough to raise the level to Full mark on the dipstick.

**Important:** Do not overfill the reservoir.

## Changing the Hydraulic Filter

**Service Interval:** Every 1,000 hours—**If you are using the recommended hydraulic fluid**, replace the hydraulic filter.

Every 800 hours—**If you are not using the recommended hydraulic fluid or have ever filled the reservoir with an alternative fluid**, replace the hydraulic filter.

### **⚠ WARNING**

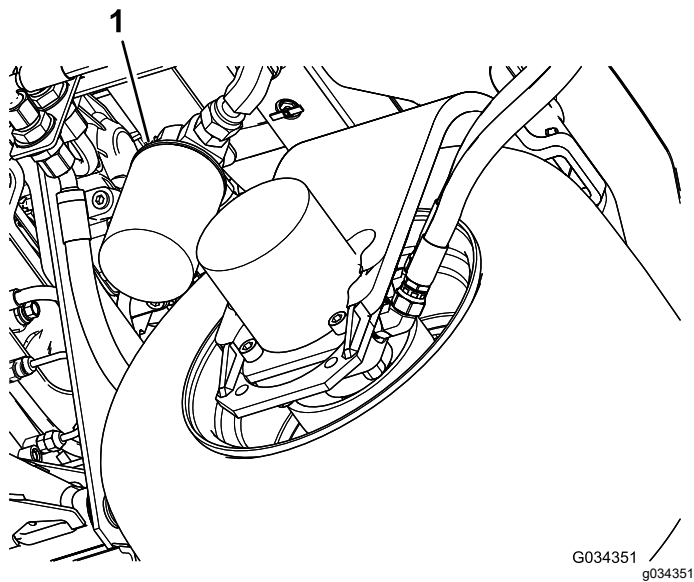
**Hot hydraulic fluid can cause severe burns.**

**Allow the hydraulic fluid to cool before performing any maintenance to the hydraulic system.**

Use a genuine Toro replacement filter, Part No. 86-3010.

**Important:** Use of any other filter may void the warranty on some components.

1. Park the machine on a level surface, lower the cutting units, engage the parking brake, shut off the engine, and remove the key from the ignition switch.
2. Clean around the filter mounting area. Place a drain pan under the filter (Figure 83) and remove the filter.



**Figure 83**

1. Hydraulic filter

3. Lubricate the new filter gasket and fill the filter with hydraulic fluid.
4. Ensure that the filter mounting area is clean. Screw the filter on until the gasket contacts the mounting plate; then tighten the filter 1/2 turn.
5. Start the engine and let it run for about 2 minutes to purge air from the system. Shut off the engine and check for leaks.

# Cutting Unit System Maintenance

## Blade Safety

A worn or damaged blade or bedknife can break, and a piece could be thrown toward you or bystanders, resulting in serious personal injury or death.

- Inspect the blades and bedknives periodically for excessive wear or damage.
- Use care when checking the blades. Wear gloves and use caution when servicing them. Only replace or backlap the blades and bedknives; never straighten or weld them.
- On machines with multiple cutting units, take care when rotating a cutting unit; it can cause the reels in the other cutting units to rotate.

## Checking the Reel-to-Bedknife Contact

**Service Interval:** Before each use or daily

Each day before operating, check the reel-to-bedknife contact, regardless of whether the quality of cut had previously been acceptable. There must be light contact across the full length of the reel and the bedknife (refer to Adjusting the Reel to Bedknife in the cutting unit *Operator's Manual*).



# Using the Optional Gauge Bar

Use the gauge bar (Figure 84) to adjust the cutting unit. Refer to the cutting unit *Operator's Manual* for the adjustment procedure.

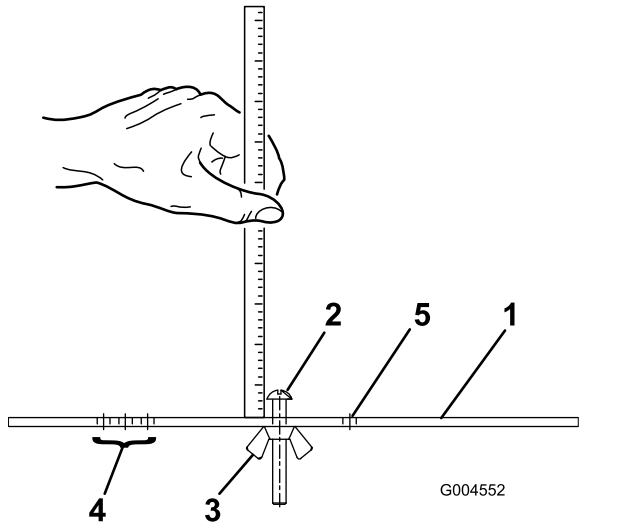


Figure 84

- |                           |                                       |
|---------------------------|---------------------------------------|
| 1. Gauge bar              | 4. Holes used for setting groomer HOG |
| 2. Height adjusting screw | 5. Hole not used                      |
| 3. Nut                    |                                       |

# Backlapping the Cutting Units

## ⚠ WARNING

Contact with the cutting units or other moving parts can result in personal injury.

- Keep your fingers, hands, and clothing away from the cutting units and other moving parts.
- Never attempt to turn the cutting units by hand or foot while the engine is running.

**Note:** When backlapping, all the cutting units operate together.

1. Park the machine on a level surface, lower the cutting units, engage the parking brake, shut off the engine, and move the Enable/Disable switch to the DISABLE position.
2. Raise the floor panel to expose the controls.
3. Make the initial reel-to-bedknife adjustments appropriate for backlapping; refer to the cutting unit *Operator's Manual*.

4. Start the engine and allow it to run at low idle speed.

## ⚠ DANGER

Changing the engine speed while backlapping may cause the cutting units to stall.

- Never change the engine speed while backlapping
- Backlap only at idle engine speed.

5. Set the reel speed control to position 1 (Figure 85).

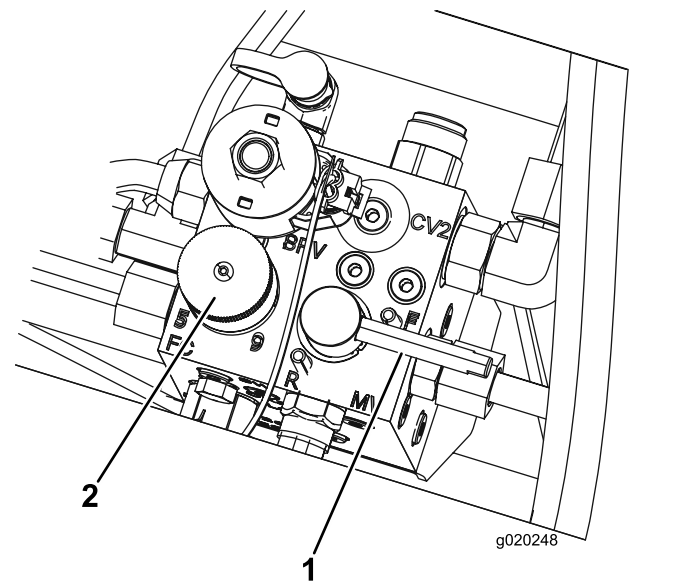


Figure 85

1. Backlap lever
2. Reel speed control knob

6. Move the backlap lever to the R (backlap) position (Figure 85).

## ⚠ DANGER

Contacting the cutting units when they are moving could cause personal injury.

To avoid personal injury, be certain that you are clear of the cutting units before proceeding.

7. With the Mow/Transport lever in the MOW position, move the Enable/Disable switch to the ENABLE position. Move the Lower Mow/Lift control forward to start the backlapping operation on the designated cutting units.
8. Apply lapping compound with a long-handle brush. Never use a short-handled brush.

9. If the cutting units stall or become erratic while backlapping, select a higher reel speed setting until the speed stabilizes, then return the reel speed to setting 1 or to your desired speed.
10. To make an adjustment to the cutting units while backlapping, turn the cutting units off by moving the Lower Mow/Raise lever rearward; the Enable/Disable switch to the DISABLE position, and shut off the engine. After completing the adjustments, repeat steps 5 through 9.
11. Repeat the procedure for all the cutting units that you want to backlap.
12. When you are finished, return the backlap lever to the Mow position, lower the floor panel, and wash all lapping compound off of the cutting units. Adjust the cutting unit reel-to-bedknife contact as needed. Move the cutting unit reel speed control to the desired mowing position.

**Important:** If the backlap switch is not returned to the F (Mow) position after backlapping, the cutting units will not raise or function properly.

**Note:** For a better cutting edge, run a file across the front face of the bedknife after lapping. This removes any burrs or rough edges that may have built up on the cutting edge.

## Cleaning

### Washing the Machine

Wash the machine as needed using water alone or with a mild detergent. You may use a rag when washing the machine.

**Important:** Do not use brackish or reclaimed water to clean the machine.

**Important:** Do not use power-washing equipment to wash the machine. Power-washing equipment may damage the electrical system, loosen important decals, or wash away necessary grease at friction points. Avoid excessive use of water near the control panel, engine, and battery.

**Important:** Do not wash the machine with the engine running. Washing the machine with the engine running may result in internal engine damage.

# Storage

## Storage Safety

- Shut off the engine, remove the key, and wait for all movement to stop before you leave the operator's position. Allow the machine to cool before adjusting, servicing, cleaning, or storing it.
- Do not store the machine or fuel container where there is an open flame, spark, or pilot light, such as on a water heater or other appliance.

## Preparing the Traction Unit

1. Park the machine on a level surface, lower the cutting units, engage the parking brake, shut off the engine, and remove the key.
2. Thoroughly clean the traction unit, cutting units, and the engine.
3. Check the tire pressure; refer to [Checking the Tire Pressure \(page 45\)](#).
4. Check all fasteners for looseness; tighten them as necessary.
5. Grease or oil all grease fittings and pivot points. Wipe up any excess lubricant.
6. Lightly sand and use touch-up paint on painted areas that are scratched, chipped, or rusted. Repair any dents in the metal body.
7. Service the battery and cables as follows; refer to [Electrical System Safety \(page 44\)](#):
  - A. Remove the battery terminals from the battery posts.
  - B. Clean the battery, terminals, and posts with a wire brush and baking-soda solution.
  - C. Coat the cable terminals and battery posts with Grafo 112X skin-over grease (Toro Part No. 505-47) or petroleum jelly to prevent corrosion.
  - D. Slowly charge the battery every 60 days for 24 hours to prevent lead sulfation of the battery.

## Preparing the Engine

1. Drain the engine oil from the oil pan and install the drain plug.
2. Remove and discard the oil filter. Install a new oil filter.
3. Fill the engine with specified motor oil.
4. Start the engine and run it at idle speed for approximately 2 minutes.
5. Shut off the engine and remove the key.
6. Flush the fuel tank with fresh, clean fuel.
7. Secure all of the fuel-system fittings.
8. Thoroughly clean and service the air-cleaner assembly.
9. Seal the air-cleaner inlet and the exhaust outlet with weatherproof tape.
10. Check the antifreeze protection and add a 50/50 solution of water and ethylene glycol antifreeze as needed for the expected minimum temperature in your area.

**Notes:**

**Notes:**

## EEA/UK Privacy Notice

### **Toro's Use of Your Personal Information**

The Toro Company ("Toro") respects your privacy. When you purchase our products, we may collect certain personal information about you, either directly from you or through your local Toro company or dealer. Toro uses this information to fulfil contractual obligations - such as to register your warranty, process your warranty claim or to contact you in the event of a product recall - and for legitimate business purposes - such as to gauge customer satisfaction, improve our products or provide you with product information which may be of interest. Toro may share your information with our subsidiaries, affiliates, dealers or other business partners in connection these activities. We may also disclose personal information when required by law or in connection with the sale, purchase or merger of a business. We will never sell your personal information to any other company for marketing purposes.

### **Retention of your Personal Information**

Toro will keep your personal information as long as it is relevant for the above purposes and in accordance with legal requirements. For more information about applicable retention periods please contact [legal@toro.com](mailto:legal@toro.com).

### **Toro's Commitment to Security**

Your personal information may be processed in the US or another country which may have less strict data protection laws than your country of residence. Whenever we transfer your information outside of your country of residence, we will take legally required steps to ensure that appropriate safeguards are in place to protect your information and to make sure it is treated securely.

### **Access and Correction**

You may have the right to correct or review your personal data, or object to or restrict the processing of your data. To do so, please contact us by email at [legal@toro.com](mailto:legal@toro.com). If you have concerns about the way in which Toro has handled your information, we encourage you to raise this directly with us. Please note that European residents have the right to complain to your Data Protection Authority.

# California Proposition 65 Warning Information

## What is this warning?

You may see a product for sale that has a warning label like the following:



**WARNING: Cancer and Reproductive Harm—[www.p65Warnings.ca.gov](http://www.p65Warnings.ca.gov).**

## What is Prop 65?

Prop 65 applies to any company operating in California, selling products in California, or manufacturing products that may be sold in or brought into California. It mandates that the Governor of California maintain and publish a list of chemicals known to cause cancer, birth defects, and/or other reproductive harm. The list, which is updated annually, includes hundreds of chemicals found in many everyday items. The purpose of Prop 65 is to inform the public about exposure to these chemicals.

Prop 65 does not ban the sale of products containing these chemicals but instead requires warnings on any product, product packaging, or literature with the product. Moreover, a Prop 65 warning does not mean that a product is in violation of any product safety standards or requirements. In fact, the California government has clarified that a Prop 65 warning "is not the same as a regulatory decision that a product is 'safe' or 'unsafe.'" Many of these chemicals have been used in everyday products for years without documented harm. For more information, go to <https://oag.ca.gov/prop65/faqs-view-all>.

A Prop 65 warning means that a company has either (1) evaluated the exposure and has concluded that it exceeds the "no significant risk level"; or (2) has chosen to provide a warning based on its understanding about the presence of a listed chemical without attempting to evaluate the exposure.

## Does this law apply everywhere?

Prop 65 warnings are required under California law only. These warnings are seen throughout California in a wide range of settings, including but not limited to restaurants, grocery stores, hotels, schools, and hospitals, and on a wide variety of products. Additionally, some online and mail order retailers provide Prop 65 warnings on their websites or in catalogs.

## How do the California warnings compare to federal limits?

Prop 65 standards are often more stringent than federal and international standards. There are various substances that require a Prop 65 warning at levels that are far lower than federal action limits. For example, the Prop 65 standard for warnings for lead is 0.5 µg/day, which is well below the federal and international standards.

## Why don't all similar products carry the warning?

- Products sold in California require Prop 65 labelling while similar products sold elsewhere do not.
- A company involved in a Prop 65 lawsuit reaching a settlement may be required to use Prop 65 warnings for its products, but other companies making similar products may have no such requirement.
- The enforcement of Prop 65 is inconsistent.
- Companies may elect not to provide warnings because they conclude that they are not required to do so under Prop 65; a lack of warnings for a product does not mean that the product is free of listed chemicals at similar levels.

## Why does Toro include this warning?

Toro has chosen to provide consumers with as much information as possible so that they can make informed decisions about the products they buy and use. Toro provides warnings in certain cases based on its knowledge of the presence of one or more listed chemicals without evaluating the level of exposure, as not all the listed chemicals provide exposure limit requirements. While the exposure from Toro products may be negligible or well within the "no significant risk" range, out of an abundance of caution, Toro has elected to provide the Prop 65 warnings. Moreover, if Toro does not provide these warnings, it could be sued by the State of California or by private parties seeking to enforce Prop 65 and subject to substantial penalties.



# The Toro Warranty

Two-Year or 1,500 Hours Limited Warranty

## Conditions and Products Covered

The Toro Company and its affiliate, Toro Warranty Company, pursuant to an agreement between them, jointly warrant your Toro Commercial product ("Product") to be free from defects in materials or workmanship for 2 years or 1,500 operational hours\*, whichever occurs first. This warranty is applicable to all products with the exception of Aerators (refer to separate warranty statements for these products). Where a warrantable condition exists, we will repair the Product at no cost to you including diagnostics, labor, parts, and transportation. This warranty begins on the date the Product is delivered to the original retail purchaser.

\* Product equipped with an hour meter.

## Instructions for Obtaining Warranty Service

You are responsible for notifying the Commercial Products Distributor or Authorized Commercial Products Dealer from whom you purchased the Product as soon as you believe a warrantable condition exists. If you need help locating a Commercial Products Distributor or Authorized Dealer, or if you have questions regarding your warranty rights or responsibilities, you may contact us at:

Toro Commercial Products Service Department  
Toro Warranty Company  
8111 Lyndale Avenue South  
Bloomington, MN 55420-1196  
952-888-8801 or 800-952-2740  
E-mail: commercial.warranty@toro.com

## Owner Responsibilities

As the product owner, you are responsible for required maintenance and adjustments stated in your *Operator's Manual*. Repairs for product issues caused by failure to perform required maintenance and adjustments are not covered under this warranty.

## Items and Conditions Not Covered

Not all product failures or malfunctions that occur during the warranty period are defects in materials or workmanship. This warranty does not cover the following:

- Product failures which result from the use of non-Toro replacement parts, or from installation and use of add-on, or modified non-Toro branded accessories and products.
- Product failures which result from failure to perform recommended maintenance and/or adjustments.
- Product failures which result from operating the Product in an abusive, negligent, or reckless manner.
- Parts consumed through use that are not defective. Examples of parts which are consumed, or used up, during normal Product operation include, but are not limited to, brake pads and linings, clutch linings, blades, reels, rollers and bearings (sealed or greasable), bed knives, spark plugs, castor wheels and bearings, tires, filters, belts, and certain sprayer components such as diaphragms, nozzles, flow meters, and check valves.
- Failures caused by outside influence, including, but not limited to, weather, storage practices, contamination, use of unapproved fuels, coolants, lubricants, additives, fertilizers, water, or chemicals.
- Failure or performance issues due to the use of fuels (e.g. gasoline, diesel, or biodiesel) that do not conform to their respective industry standards.
- Normal noise, vibration, wear and tear, and deterioration. Normal "wear and tear" includes, but is not limited to, damage to seats due to wear or abrasion, worn painted surfaces, scratched decals or windows.

## Countries Other than the United States or Canada

Customers who have purchased Toro products exported from the United States or Canada should contact their Toro Distributor (Dealer) to obtain guarantee policies for your country, province, or state. If for any reason you are dissatisfied with your Distributor's service or have difficulty obtaining guarantee information, contact your Authorized Toro Service Center.

## Parts

Parts scheduled for replacement as required maintenance are warranted for the period of time up to the scheduled replacement time for that part. Parts replaced under this warranty are covered for the duration of the original product warranty and become the property of Toro. Toro will make the final decision whether to repair any existing part or assembly or replace it. Toro may use remanufactured parts for warranty repairs.

## Deep Cycle and Lithium-Ion Battery Warranty

Deep cycle and Lithium-Ion batteries have a specified total number of kilowatt-hours they can deliver during their lifetime. Operating, recharging, and maintenance techniques can extend or reduce total battery life. As the batteries in this product are consumed, the amount of useful work between charging intervals will slowly decrease until the battery is completely worn out. Replacement of worn out batteries, due to normal consumption, is the responsibility of the product owner. Note: (Lithium-Ion battery only): Refer to the battery warranty for additional information.

## Lifetime Crankshaft Warranty (ProStripe 02657 Model Only)

The Prostripe which is fitted with a genuine Toro Friction Disc and Crank-Safe Blade Brake Clutch (integrated Blade Brake Clutch (BBC) + Friction Disc assembly) as original equipment and used by the original purchaser in accordance with recommended operating and maintenance procedures, are covered by a Lifetime Warranty against engine crankshaft bending. Machines fitted with friction washers, Blade Brake Clutch (BBC) units and other such devices are not covered by the Lifetime Crankshaft Warranty.

## Maintenance is at Owner's Expense

Engine tune-up, lubrication, cleaning and polishing, replacement of filters, coolant, and completing recommended maintenance are some of the normal services Toro products require that are at the owner's expense.

## General Conditions

Repair by an Authorized Toro Distributor or Dealer is your sole remedy under this warranty.

**Neither The Toro Company nor Toro Warranty Company is liable for indirect, incidental or consequential damages in connection with the use of the Toro Products covered by this warranty, including any cost or expense of providing substitute equipment or service during reasonable periods of malfunction or non-use pending completion of repairs under this warranty. Except for the Emissions warranty referenced below, if applicable, there is no other express warranty. All implied warranties of merchantability and fitness for use are limited to the duration of this express warranty.**

Some states do not allow exclusions of incidental or consequential damages, or limitations on how long an implied warranty lasts, so the above exclusions and limitations may not apply to you. This warranty gives you specific legal rights, and you may also have other rights which vary from state to state.

## Note Regarding Emissions Warranty

The Emissions Control System on your Product may be covered by a separate warranty meeting requirements established by the U.S. Environmental Protection Agency (EPA) and/or the California Air Resources Board (CARB). The hour limitations set forth above do not apply to the Emissions Control System Warranty. Refer to the Engine Emission Control Warranty Statement supplied with your product or contained in the engine manufacturer's documentation.