



Count on it.

Operator's Manual

8in Earth Auger

Model No. 58630—Serial No. 321000001 and Up

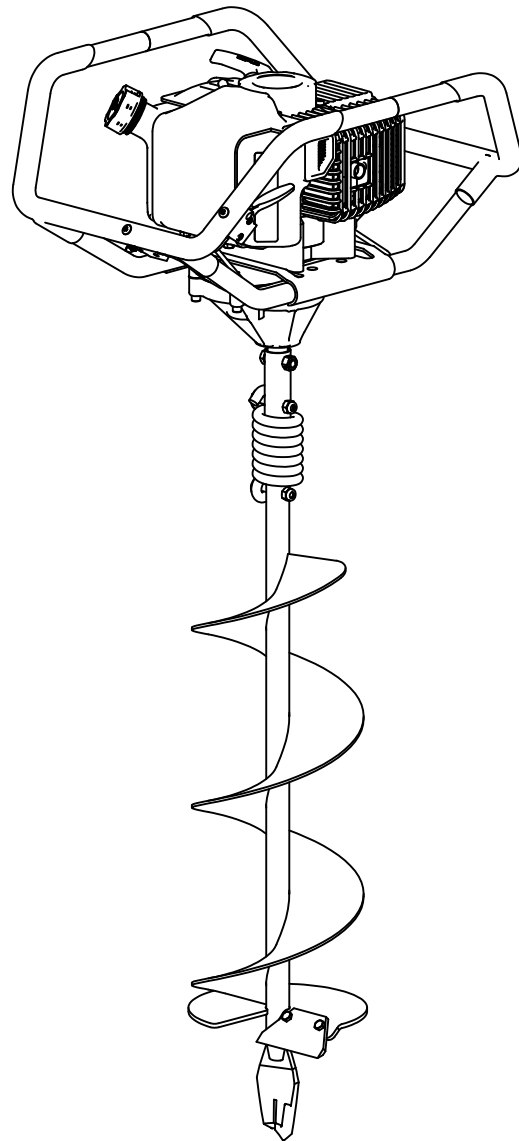

It is a violation of California Public Resource Code Section 4442 or 4443 to use or operate the engine on any forest-covered, brush-covered, or grass-covered land unless the engine is equipped with a spark arrester, as defined in Section 4442, maintained in effective working order or the engine is constructed, equipped, and maintained for the prevention of fire.

⚠ WARNING

**CALIFORNIA
Proposition 65 Warning**

The engine exhaust from this product contains chemicals known to the State of California to cause cancer, birth defects, or other reproductive harm.

Use of this product may cause exposure to chemicals known to the State of California to cause cancer, birth defects, or other reproductive harm.

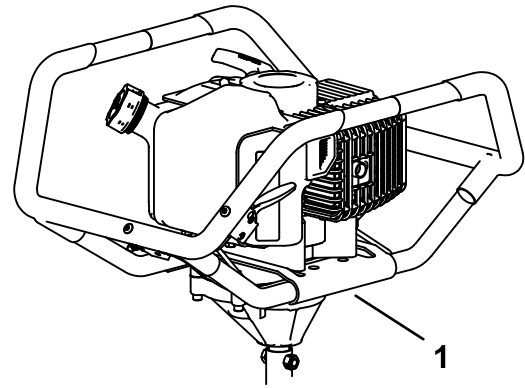

Figure 1

g356701

1. Model and serial number location

Model No. _____

Serial No. _____

Introduction

This earth auger is designed primarily to dig vertical holes in the earth for the installation of posts, plants, and other construction and landscaping needs. Using this product for purposes other than its intended use could prove dangerous to you and bystanders.

Read this information carefully to learn how to operate and maintain your product properly and to avoid injury and product damage. You are responsible for operating the product properly and safely.

Visit www.Toro.com for more information, including safety tips, training materials, accessory information, help finding a dealer, or to register your product.

Whenever you need service, genuine Toro parts, or additional information, contact an Authorized Service Dealer or Toro Customer Service and have the model and serial numbers of your product ready. [Figure 1](#) identifies the location of the model and serial numbers on the product. Write the numbers in the space provided.

This manual uses 2 words to highlight information. **Important** calls attention to special mechanical information and **Note** emphasizes general information worthy of special attention.

The safety-alert symbol ([Figure 2](#)) appears both in this manual and on the machine to identify important safety messages that you must follow to avoid accidents. This symbol will appear with the word **Danger**, **Warning**, or **Caution**.

- **Danger** indicates an imminently hazardous situation which, if not avoided, **will** result in death or serious injury.
- **Warning** indicates a potentially hazardous situation which, if not avoided, **could** result in death or serious injury.
- **Caution** indicates a potentially hazardous situation which, if not avoided, **may** result in minor or moderate injury.



Figure 2

Safety-alert symbol

g000502

Contents

Safety	3
General Safety	3
Safety and Instructional Decals	4
Setup	5
Assembling the Auger.....	6
Product Overview	7
Controls	7
Specifications	8
Attachments/Accessories	8
Before Operation	9
Before Operation Safety	9
Adding Fuel	10
Performing Daily Maintenance.....	10
During Operation	11
During Operation Safety	11
Starting the Engine	12
Operating the Auger	12
Shutting Off the Engine.....	12
After Operation	13
After Operation Safety	13
Maintenance	14
Maintenance Safety.....	14
Recommended Maintenance Schedule(s)	14
Pre-Maintenance Procedures	15
Preparing for Maintenance	15
Engine Maintenance	15
Servicing the Air Filter.....	15
Servicing the Spark Plug.....	16
Auger Maintenance.....	17
Maintaining the Auger.....	17
Storage	18
Storage Safety.....	18
Cleaning and Storing the Machine	18
Troubleshooting	19

Safety

General Safety

▲ DANGER

There may be buried utility lines in the work area. Digging into them may cause a shock or an explosion.

Have the property or work area marked for buried lines and do not dig in marked areas. Contact your local marking service or utility company to have the property marked (for example, in the US, call 811 for the nationwide marking service).

- Read, understand, and follow the instructions and warnings in this Operator's Manual and on the machine and attachments before starting the engine.
- Be thoroughly familiar with the controls and the proper use of the equipment. Know how to stop the machine and disengage the controls quickly.
- Do not allow your hands, feet, or other body parts or clothing near or under rotating parts or any other moving parts of the machine.
- Do not operate the machine without all proper shields, guards, and other safety protective devices in place and functioning properly on the machine.
- Keep bystanders, especially small children, and pets out of the operating area.
- Do not allow children to operate the machine. Allow only people who are responsible, trained, familiar with the instructions, and physically capable to operate the machine.
- Shut off the machine and wait for all moving parts to stop before you leave the operator's position. Disconnect the spark-plug wire, keep it away from the plug to prevent accidental starting, and allow the machine to cool before adjusting, fueling, unclogging, servicing, cleaning, or storing the machine.

Improperly using or maintaining this machine can result in injury. To reduce the potential for injury, comply with these safety instructions and always pay attention to the safety-alert symbol ▲, which means Caution, Warning, or Danger—personal safety instruction. Failure to comply with these instructions may result in personal injury or death.

Safety and Instructional Decals



Safety decals and instructions are easily visible to the operator and are located near any area of potential danger. Replace any decal that is damaged or missing.



133-8062

decal133-8062



144-5143

g368764

1. Move the engine switch to the ON position.
2. Press the primer bulb 3 times.
3. Move the choke lever to the CHOKE position.
4. Pull the starter handle lightly until you feel resistance, then pull the handle briskly.
5. Move the choke lever to the RUN position.
6. Read the *Operator's Manual* for more info.



144-5144

decal39939

1. Warning—read the *Operator's Manual*.
2. Warning—shut off the machine before moving it.
3. Entanglement hazard, auger—stay away from moving parts; keep bystanders away.
4. Explosion and/or electric shock hazard—do not dig in areas with buried gas or power lines.
5. 50:1 Fuel-to-Oil Ratio Mix

Setup

Loose Parts

Use the chart below to verify that all parts have been shipped.

Description	Qty.	Use
Powerhead	1	Assemble the auger.
Bolt (3/8 x 1-1/2 inches)	1	
Locknut (3/8 inch)	1	
Auger	1	
Fishtail point	1	

Assembling the Auger

1. Insert the output shaft on the powerhead into the open end of the auger (Figure 3).
2. Secure the powerhead to the auger using the bolt (3/8 x 1-1/2 inches) and locknut (3/8 inch) as shown in Figure 3.
3. Secure the fishtail point to the auger (Figure 3).

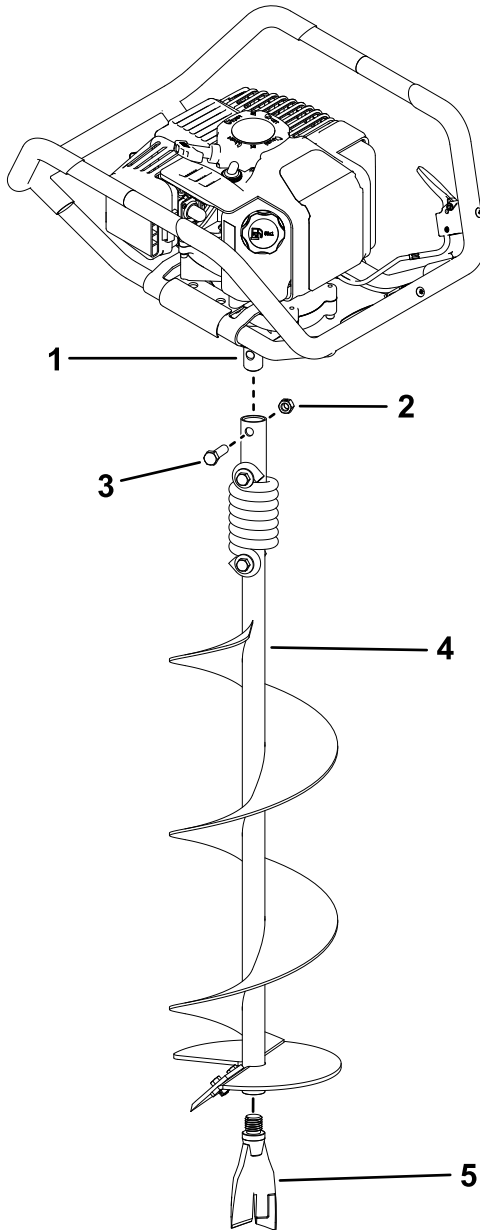

Figure 3

g356736

- | | |
|----------------------------------|-------------------|
| 1. Output shaft on the powerhead | 4. Auger |
| 2. Locknut (3/8 inch) | 5. Fishtail point |
| 3. Bolt (3/8 x 1-1/2 inches) | |

Product Overview

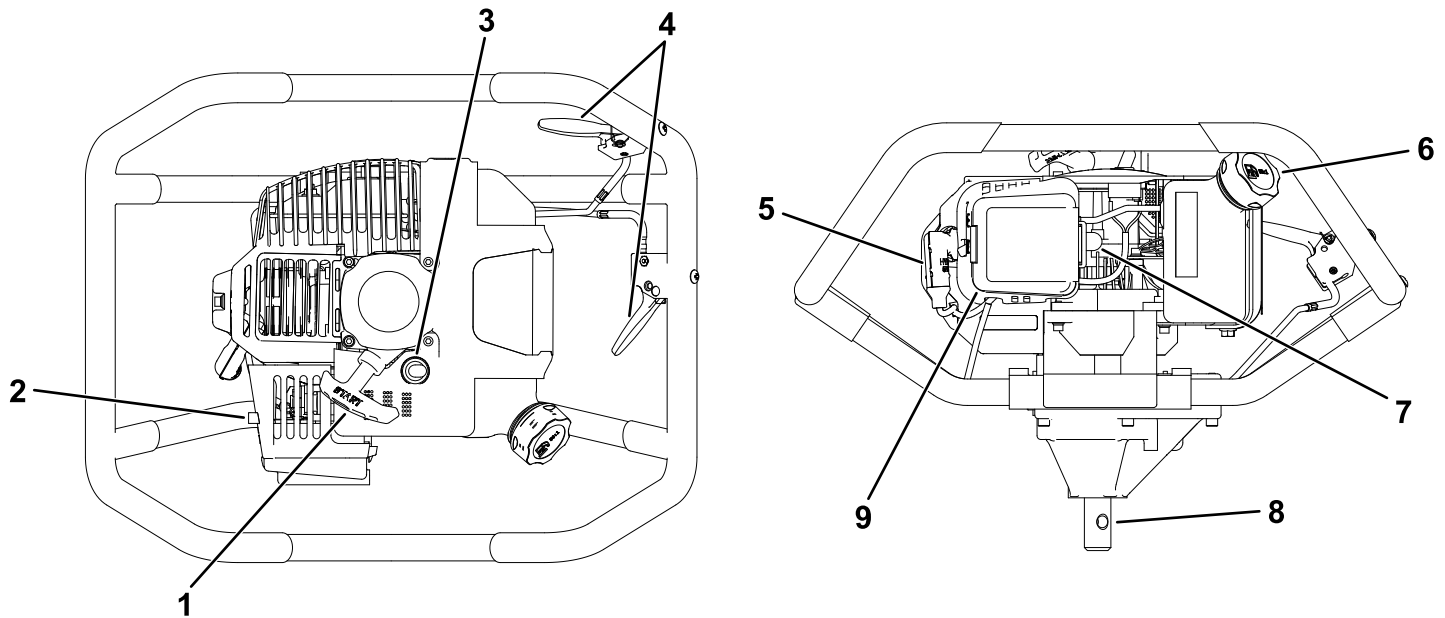

Figure 4

g356798

- | | | |
|--------------------------|----------------------|------------------|
| 1. Engine-starter handle | 4. Throttle controls | 7. Engine primer |
| 2. Choke lever | 5. Spark-plug wire | 8. Output shaft |
| 3. Engine on/off switch | 6. Fuel-tank cap | 9. Air filter |

Controls

Become familiar with all the controls before you start the engine and operate the machine.

Engine On/Off Switch

Use the engine On/Off switch to shut the engine off. Ensure that the switch is in the ON position before starting the engine.

Throttle Control

The throttle controls the engine speed, and it has a continuous-variable setting.

Operate the machine using full throttle for best performance.

Choke Lever

Move the choke lever on the engine to the CHOKE position when initially starting a cold engine, then move it into the RUN position once started.

Engine-Primer Bulb

Push the engine-primer bulb 3 times to prime the engine before starting.

Engine-Starter Handle

Pull the starter handle to start the engine.

Specifications

Specifications and design are subject to change without notice.

Height	41 cm (16-3/16 inches)
Length	122 cm (48.1 inches)
Width	51 cm (20-3/16 inches)
Weight	16 kg (35.7 lb)

Attachments/Accessories

A selection of Toro approved attachments and accessories is available for use with the machine to enhance and expand its capabilities. Contact your Authorized Service Dealer or authorized Toro distributor or go to www.Toro.com for a list of all approved attachments and accessories.

To ensure optimum performance and continued safety certification of the machine, use only genuine Toro replacement parts and accessories. Replacement parts and accessories made by other manufacturers could be dangerous, and such use could void the product warranty.

Operation

Note: Determine the left and right sides of the machine from the normal operating position.

Before Operation

Before Operation Safety

General Safety

- Do not allow children to operate the machine. Allow only people who are responsible, trained, familiar with the instructions, and physically capable to operate the machine.
- Working with this machine is strenuous. You must be in good physical condition and mentally alert. If you have any condition that might be aggravated by strenuous work, check with your doctor before operating this machine.
- Shut off the engine and wait for all moving parts to stop before leaving the operating position. Disconnect the spark-plug wire (and keep it away from the plug to prevent accidental starting) and allow the machine to cool before unclogging, fueling, inspecting, adjusting, servicing, cleaning, or storing it.
- Become familiar with the safe operation of the equipment, operator controls, and safety signs.
- Do not operate the machine without proper shields, guards, or other safety protective devices in place.
- Keep the operating area clear of all persons, particularly small children, and pets.
- Thoroughly inspect the area where you will use the equipment and remove all foreign objects.
- Become familiar with all the safety and operating decals on the machine and its attachments or accessories.
- Do not use the machine above underground utilities, including water lines, gas lines, electric cables, or pipes.

Fuel Safety

- Use extreme care in handling fuel. Fuel is extremely flammable and its vapors are explosive.
- Do not refuel the machine indoors. Fill the fuel tank outdoors with extreme care.
- Extinguish all cigarettes, cigars, pipes, and other sources of ignition.
- Do not remove the fuel cap or add fuel to a hot or running engine.
- Allow the engine to cool before refueling.
- Do not overfill the fuel tank. Replace the fuel cap and tighten it securely. Clean up spilled fuel before starting the engine.
- If you must drain the fuel tank, do it outdoors.
- Use only an approved fuel container.
- Do not fill containers inside a vehicle or on a truck or trailer bed with a plastic liner. Always place containers on the ground away from your vehicle before filling.
- Remove fuel-powered equipment from the truck or trailer and refuel it on the ground. If this is not possible, then refuel such equipment with a portable container rather than from a fuel-dispenser nozzle.
- Keep the nozzle in contact with the rim of the fuel tank or container opening at all times until fueling is complete. Do not use a nozzle lock-open device.
- If you spill fuel, do not attempt to start the engine but move the machine away from the spill and avoid creating any source of ignition until the fuel vapors have dissipated.
- If you spill fuel on your clothing, change your clothing immediately.
- Do not store the machine with fuel in the fuel tank or the fuel container inside a building where ignition sources (an open flame, spark, or pilot light) are present, such as on hot water and space heaters, clothes dryers, etc. Allow the engine to cool before storing in any enclosure.
- Fuel is harmful or fatal if swallowed. Long-term exposure to vapors can cause serious injury and illness.
 - Avoid prolonged breathing of vapors.
 - Keep your hands and face away from the nozzle and the fuel-tank opening.
 - Keep fuel away from your eyes and skin.

Adding Fuel

Recommended Fuel

Type	Unleaded gasoline
Minimum octane rating	87 (US) or 91 (research octane; outside the US)
Ethanol	No more than 10% by volume
Methanol	None
MTBE (methyl tertiary butyl ether)	Less than 15% by volume
Oil	2-cycle oil; mixed in 50:1 fuel-to-oil ratio

Use only clean, fresh (no more than 30 days old), fuel from a reputable source.

Mixing Fuel

This product is powered by a 2-cycle engine and requires pre-mixing fuel and 2-cycle oil. Pre-mix unleaded gasoline and 2-cycle engine oil in a clean container approved for fuel. Do not mix quantities larger than usable in a 30-day period.

Important: To prevent engine damage, do not use automotive oil (such as SAE 30 or 10W30) or fuel mixed at the wrong fuel-to-oil ratio.

50:1 Fuel-to-Oil Ratio Mixing Chart

Fuel	Oil
3.8 L (1 US gallon)	76 ml (2.6 fl oz)
7.6 L (2 US gallons)	152 ml (5.1 fl oz)
19 L (5 US gallons)	380 ml (13 fl oz)

1. Pour 1.9 L (0.5 US gallon) fresh, unleaded fuel into an approved fuel container.
2. Add 2-cycle oil to the fuel according to the chart.

Note: When you purchase the machine, you will receive a 76 ml (2.6 fl oz) bottle of oil. Mix this bottle with 3.8 L (1 US gallon) of recommended fuel.

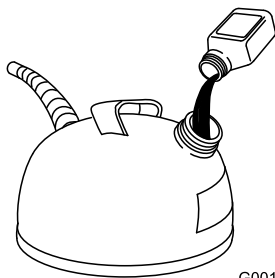

G001120

g001120

Figure 5

3. Install the cap on the fuel container.
4. Shake the container to mix the fuel and oil thoroughly.
5. Slowly remove the cap and add the remaining amount of fuel.

Note: Do not mix fuel and oil in the fuel tank. Oil at room temperature mixes easier and more thoroughly than cold oil. Oil below 0°C (32°F) requires additional mixing.

Using Stabilizer/Conditioner

Use fuel stabilizer/conditioner in the machine to keep the fuel fresh longer when used as directed by the fuel-stabilizer manufacturer.

Important: Do not use fuel additives containing methanol or ethanol.

Add the amount of fuel stabilizer/conditioner to fresh fuel as directed by the fuel-stabilizer manufacturer.

Filling the Fuel Tank

Fuel-tank capacity: 1.1 L (36 fl oz)

Refer to your engine owner's manual for additional information.

Fill the fuel tank as shown in [Figure 6](#).

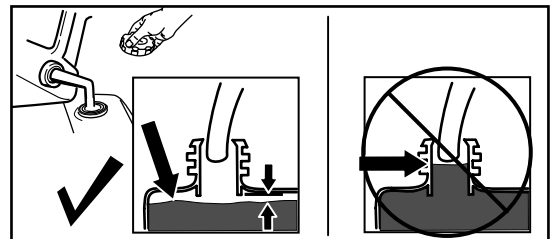

g230458

Figure 6

Performing Daily Maintenance

Before starting the machine each day, perform the Each Use/Daily procedures listed in [Maintenance \(page 14\)](#).

During Operation

During Operation Safety

General Safety

- Wear appropriate clothing, including eye protection; long pants; substantial, slip-resistant footwear; work gloves; and hearing protection. Tie back long hair and do not wear loose clothing or loose jewelry.
- Use your full attention while operating the machine. Do not engage in any activity that causes distractions; otherwise, injury or property damage may occur.
- Do not operate the machine while ill, tired, or under the influence of alcohol or drugs.
- Do not allow your hands, feet, or other body parts or clothing near or under the moving parts. The auger begins rotating once you start the engine and engage the activating device. The auger may momentarily rotate after you release the activating device.
- Keep the operating area clear of all persons, particularly small children, and pets.
- Disengage all clutches and shift the transmission into neutral before starting the engine.
- Start the engine carefully according to the instructions and with your feet away from the auger.
- Never pick up or carry a machine while the engine is running.
- Do not operate the machine without good visibility or light.
- Avoid operating the machine in wet grass. Always be sure of your footing; keep a firm hold on the handle and walk; never run.
- Exercise caution to avoid slipping or falling.
- After striking a foreign object, shut off the engine, disconnect the spark-plug wire, thoroughly inspect the machine (especially the powerhead and the auger) for any damage, and repair the machine before starting and operating the machine.
- If the machine should start to vibrate abnormally, shut off the engine and check immediately for the cause. Vibration is generally a warning sign of trouble.
- Shut off the engine and wait for all moving parts to stop before leaving the operating position. Disconnect the spark-plug wire (and keep it away from the plug to prevent accidental starting) and allow the machine to cool before unclogging, fueling, inspecting, adjusting, servicing, cleaning, or storing it.
- The temperature of the muffler and nearby areas may be hot enough to cause a burn. Allow the muffler and engine areas to cool before touching them.
- Do not operate the engine in a confined space, where dangerous carbon monoxide fumes can collect.
- Never attempt to make any adjustments while the engine is running except where specifically recommended by Toro.
- Do not change the engine governor settings or over speed the engine. Use only attachments and accessories approved by the manufacturer of the machine (such as wheel weights, counterweights, cabs, etc.).
- Avoid prolonged exposure to noise and vibration from engine-powered equipment. Take intermittent breaks and/or wear hearing protection from engine noise as well as heavy work gloves to reduce the vibration in the hands.
- Do not transport the machine from one place to another with the engine running.
- The auger should not rotate when you release the drive control lever into the Neutral position. If the machine does rotate when in neutral, contact customer service for instructions.
- If an object becomes lodged in the auger, shut off the engine and allow it to cool before attempting to remove the foreign object.
- Do not run the engine outdoors where exhaust fumes may be pulling into a building.
- Do not run the engine outdoors in a poorly ventilated area, where the exhaust fumes may be trapped and not easily taken away (e.g., in a large hole or areas where hills surround your working area).
- Always run the engine with the exhaust and muffler directed away from you.
- Do not direct the exhaust muffler toward anyone. People should always be away during operation.
- Do not leave the machine unattended when the engine is running.
- The auger should not rotate when the engine is idling; otherwise, contact an Authorized Service Dealer.
- The earth blade is very sharp. Use extreme caution when drilling a hole or replacing the blade.

Starting the Engine

1. Seat the auger tip into the earth at the location of the desired hole.
2. Press the primer bulb until the primer hose is filled with gasoline. Allow the bulb to return to its original position between presses.

Note: A warm or hot engine may not require priming.

3. Move the choke lever to the CHOKE position.

Note: A warm or hot engine may not require choking.

4. Press the engine On/Off switch to the ON position.
5. Grab the handle bar with 1 hand, With your other hand, pull the starter handle lightly until you feel resistance, then pull the handle briskly. Return the starter handle gently.

Note: If the engine does not start after 5 or 6 pulls, press the primer bulb once and pull the starter handle again.

6. Once the engine is running, move the choke lever midway between the CHOKE and RUN positions.
7. When the engine runs smoothly, move the choke lever to the RUN position.
8. Squeeze the throttle lever to the desired speed.

Note: Use full throttle when possible. Do not let the machine idle for extended periods of time.

Operating the Auger

⚠ DANGER

There may be buried utility lines in the work area. Digging into them may cause a shock or an explosion.

Have the property or work area marked for buried lines and do not dig in marked areas. Contact your local marking service or utility company to have the property marked (for example, in the US, call 811 for the nationwide marking service).

Note: Using 2 operators eases clearing the hole and lifting the auger.

Important: Do not operate the machine on ice; otherwise, you may damage the machine.

1. Start the engine as described in [Starting the Engine \(page 12\)](#).
2. Squeeze the throttle lever on the right handlebar until the engine speed (rpm) increases and the clutch engages.
3. Drill holes as required. Do not place excessive body weight on the unit.
 - In most soils, the auger operates most efficiently with a shaving action caused by the weight of the machine.
 - Pay attention to the amount of earth you are removing from the hole. As the auger goes deeper, you need to lift more dirt from the hole. Lift the machine from the hole frequently to ensure you can lift the weight.

Note: The clutch will transfer maximum power after approximately 2 hours of normal operation. During this break-in period, clutch slippage may occur. Keep the clutch free of oil and moisture for efficient operation.

Shutting Off the Engine

1. Release the throttle lever.
2. Remain in the operating position and grab the handle bar with 1 hand.
3. Move the engine On/Off switch to the OFF position.
4. Wait for all moving parts to stop before leaving the operating position.

After Operation

After Operation Safety

General Safety

- Shut off the engine and wait for all moving parts to stop before leaving the operating position. Disconnect the spark-plug wire (and keep it away from the plug to prevent accidental starting) and allow the machine to cool before unclogging, fueling, inspecting, adjusting, servicing, cleaning, or storing it.
- Clean debris from the machine to help prevent fires. Clean up oil or fuel spills.
- Follow the instructions in this *Operator's Manual* for safe loading, unloading, transport, and storage of the machine.

Hauling Safety

- Disconnect the spark-plug wire before loading the machine for hauling.
- Use care when loading or unloading the machine.

Maintenance

Maintenance Safety

- Shut off the engine and wait for all moving parts to stop before leaving the operating position. Disconnect the spark-plug wire (and keep it away from the plug to prevent accidental starting) and allow the machine to cool before unclogging, fueling, inspecting, adjusting, servicing, cleaning, or storing it.
- Wear gloves and eye protection when servicing the machine.
- Keep the machine, attachments, and accessories in safe working condition.
- Keep all parts in good working condition. Check shear bolts, engine mounting bolts, and other bolts at frequent intervals for proper tightness to ensure that the machine is in safe working condition.
- Do not attempt to repair the machine unless you have the proper tools and instructions for disassembly, assembly, and repair of the machine.
- Regularly inspect the machine. Ensure that parts are not bent, damaged, or loose.
- To ensure optimum performance of the machine, use only genuine Toro replacement parts and accessories. Replacement parts and accessories made by other manufacturers could be dangerous, and such use could void the product warranty.

Recommended Maintenance Schedule(s)

Maintenance Service Interval	Maintenance Procedure
Before each use or daily	<ul style="list-style-type: none">• Check the air filter.
Every 20 hours	<ul style="list-style-type: none">• Clean the air filter. (Clean daily in extremely dusty conditions.)• Replace the air filter.• Check, clean, and gap the spark plug.
Every 50 hours	<ul style="list-style-type: none">• Open the gear case and check the grease level.
Yearly	<ul style="list-style-type: none">• Replace the air filter.• Replace the spark plug.

Pre-Maintenance Procedures

Preparing for Maintenance

1. Move the machine to a level surface, shut off the engine, and wait for all moving parts to stop.
2. Disconnect the spark-plug wire from the spark plug.

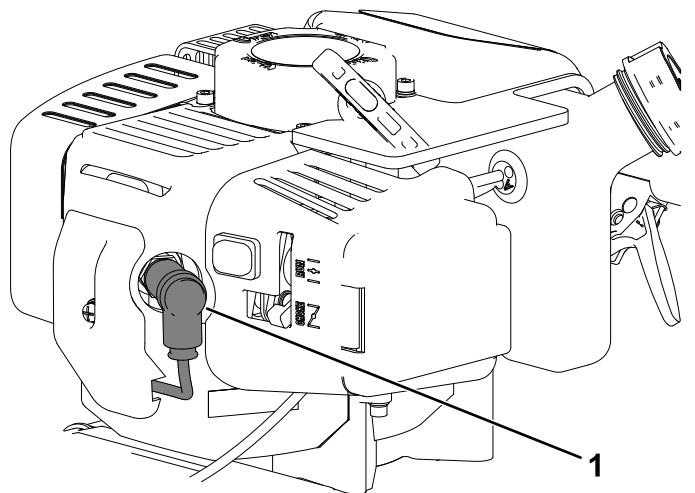

Figure 7

g356809

1. Spark-plug wire

3. After performing the maintenance procedure(s), connect the spark-plug wire to the spark plug.

Important: Before tipping the machine to replace the blade, allow the fuel tank to run dry through normal usage. If you must tip the machine prior to running out of fuel, use a hand fuel pump to remove the fuel.

Engine Maintenance

Servicing the Air Filter

Service Interval: Before each use or daily—Check the air filter.

Every 20 hours—Clean the air filter. (Clean daily in extremely dusty conditions.)

Every 20 hours—Replace the air filter.

Yearly—Replace the air filter.

1. Move the choke lever to the CHOKE position.
2. Squeeze the latch tabs and rotate the air filter cover off the machine.

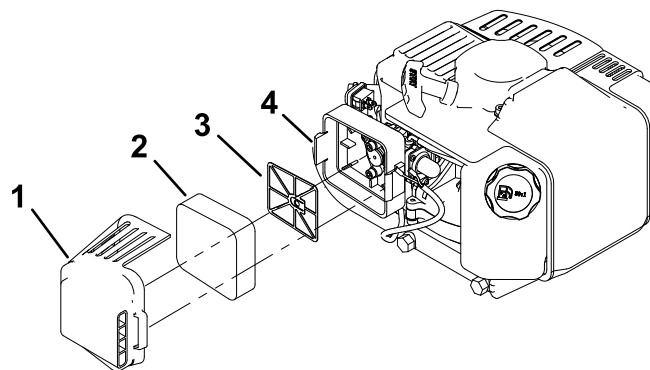

Figure 8

g335328

1. Air filter cover
2. Foam filter element
3. Filter-reinforcement plate
4. Latch tab (2)

3. Remove and inspect the foam filter element.

Important: Replace the foam element if it is torn or worn.

4. Wash the foam element in liquid soap and warm water. When the element is clean, rinse it thoroughly.

Important: Do not twist the foam element while cleaning it.

5. Dry the element by squeezing it in a clean cloth.
6. Dip the foam element in clean engine oil (30 or 40 weight), then squeeze out the excess oil.
7. Install the filter over the filter-reinforcement plate. Press the foam filter evenly over the plate to ensure it is fully seated into its sealed position.
8. Install the air filter cover. Ensure that it snaps into place and is secured by the latch tabs.

Servicing the Spark Plug

Service Interval: Every 20 hours—Check, clean, and gap the spark plug.

Yearly—Replace the spark plug.

Ensure that the air gap between the center and side electrodes is correct before installing the spark plug.

Use a spark plug wrench for removing and installing the spark plug(s) and a gapping tool/feeler gauge to check and adjust the air gap. Install a new spark plug(s) if necessary.

Type: Torch L7RTC, Champion RCJ8Y, or equivalent

Air gap: 0.71 mm (0.028 inch)

Removing the Spark Plug

1. Disconnect the spark-plug wire from the spark plug.

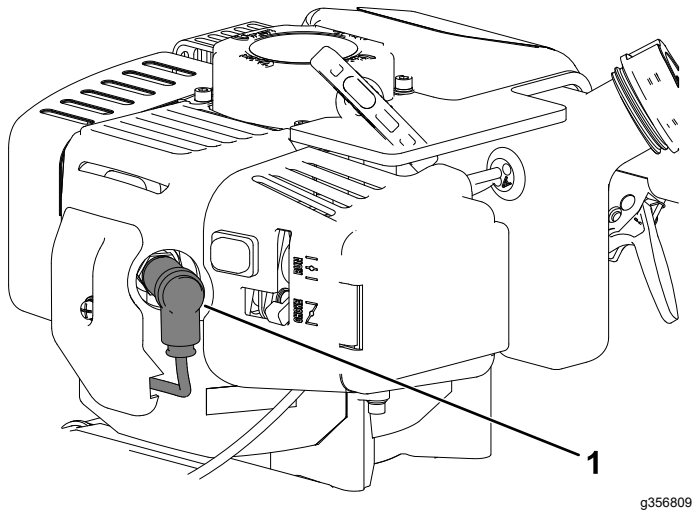

Figure 9

g356809

1. Spark-plug wire
-
2. Clean around the spark plugs to prevent dirt from entering the engine and potentially causing damage.
 3. Remove the spark plug.

Checking the Spark Plug

Important: Do not clean the spark plug(s). Always replace the spark plug(s) when it has a black coating, worn electrodes, an oily film, or cracks.

If you see light brown or gray on the insulator, the engine is operating properly. A black coating on the insulator usually means the air cleaner is dirty.

Set the gap to 0.71 mm (0.028 inch).

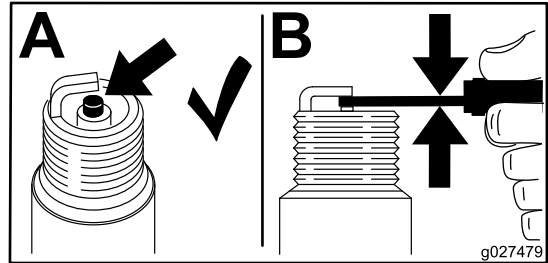

Figure 10

g027479

Installing the Spark Plug

1. Thread the spark plug clockwise into the spark-plug hole by hand.
2. Rotate the spark plug clockwise using a spark-plug wrench until the plug and sealing washer are seated.
3. Tighten the spark plug as follows:
 - When installing the original spark plug, tighten the plug an additional 1/2 turn.
 - When installing a new spark plug, tighten the plug an additional 1/8 to 1/4 turn.

Important: A loose spark plug may cause the cylinder to overheat. An over-tight spark plug may damage the threads in the cylinder head.

4. Connect the spark-plug wire to the spark plug.

Auger Maintenance

Maintaining the Auger

Service Interval: Every 50 hours

Gear case grease capacity: 118 mL (4 fl oz)

1. Add grease only if the level of the grease is below top of the gears.

Important: Do not overfill the gear case.

2. Keep all screws, nuts, and bolts tight.
3. For cold-weather operation, store the machine in a cool environment.

Important: Transferring the machine from a warm place to a cold place can cause condensation, which may damage the machine.

4. If the auger performance decreases, carefully inspect the cutting edge of the blade for signs of wear and/or damage.

If the blades show any of these signs, replace the blades.

Storage

Storage Safety

- Shut off the machine and wait for all moving parts to stop before you leave the operator's position. Disconnect the spark-plug wire, keep it away from the plug to prevent accidental starting, and allow the machine to cool before adjusting, fueling, unclogging, servicing, cleaning, or storing the machine.
- Run the engine dry or remove the fuel with a hand pump; never siphon the fuel. If you must drain the fuel tank, do it outdoors.
- Follow the instructions in this *Operator's Manual* to safely unload, transport, and store the machine.
- Do not store the machine with fuel in the fuel tank inside a building where ignition sources are present, such as hot water and space heaters and clothes dryers. Allow the engine to cool before storing the machine in an enclosure.
- Always refer to the *Operator's Manual* for important details if the machine is to be stored for an extended period.

- E. Dispose of fuel properly. Recycle the fuel according to local codes.

***Important:* Do not store fuel containing stabilizer/conditioner longer than the duration recommended by the fuel-stabilizer manufacturer.**

5. Remove and check the condition of the spark plug; refer to [Servicing the Spark Plug \(page 16\)](#). With the spark plug removed from the engine, pour 15 ml (1 tablespoon) of engine oil into the spark plug hole. Install the spark plug and pull the recoil rope 3 times to coat the cylinder with oil. Do not install the wire on the spark plug.
6. Check and tighten all fasteners. Repair or replace any part that is damaged.
7. Paint all scratched or bare metal surfaces. Paint is available from your Authorized Service Dealer.
8. Store the machine in an secure, upright position in a clean, dry garage or storage area. Keep it out of reach of children or other unauthorized users. Cover the machine to protect it and keep it clean.

Cleaning and Storing the Machine

1. Shut off the engine and wait for all moving parts to stop before leaving the operating position.
2. Remove all debris from the auger and engine.

***Important:* You can wash the machine with mild detergent and water. Do not pressure-wash the machine. Avoid excessive use of water, especially near the engine and powerhead.**

3. Service the air filter; refer to [Servicing the Air Filter \(page 15\)](#).
4. Prepare the machine for storage for over 30 days as follows:
 - A. Add fuel stabilizer/conditioner to fresh fuel in the tank. Follow mixing instructions from the fuel stabilizer manufacturer. Do not use an alcohol-based stabilizer (ethanol or methanol).
 - B. Run the engine to distribute conditioned fuel through the fuel system for 5 minutes.
 - C. Shut off the engine, allow it to cool, and drain the fuel tank.
 - D. Start the engine and run it until it shuts off.

Troubleshooting

Problem	Possible Cause	Corrective Action
The engine does not start.	<ol style="list-style-type: none"> 1. The engine switch is in the OFF position. 2. The spark-plug wire is loose or disconnected. 3. The spark plug is wet, pitted, fouled, or the gap is incorrect. 4. The fuel-line hose is not positioned at the bottom of the fuel tank. 	<ol style="list-style-type: none"> 1. Move the switch to the ON position. 2. Install the wire on the spark plug. 3. Install a new, correctly gapped spark plug. 4. Push the fuel-line hose into the fuel in the fuel tank.
The engine runs rough or floods during operation.	<ol style="list-style-type: none"> 1. The air filter is dirty. 2. The choke is partially engaged. 3. The carburetor is out of adjustment. 	<ol style="list-style-type: none"> 1. Clean or replace the air filter. 2. Move the choke lever to the RUN position. 3. Contact an Authorized Service Dealer
The engine is difficult to start.	<ol style="list-style-type: none"> 1. Stale fuel is in the fuel system. 2. The spark-plug wire is loose or disconnected. 3. The carburetor is dirty. 4. The fuel is not sufficiently primed. 	<ol style="list-style-type: none"> 1. Drain the fuel tank and add fresh fuel. 2. Install the wire on the spark plug. 3. Clean the carburetor, use fuel stabilizer, and use a new fuel can. 4. Press the primer bulb 3 times, then pull recoil handle.
The engine does not start, starts hard, or fails to keep running.	<ol style="list-style-type: none"> 1. The fuel tank is empty. 2. The choke is not engaged. 3. The air filter is dirty. 4. Dirt, water, or stale fuel is in fuel system. 5. There is incorrect fuel in the fuel tank. 	<ol style="list-style-type: none"> 1. Fill the fuel tank. 2. Move the choke lever to the CHOKE position. 3. Clean or replace the air filter. 4. Contact an Authorized Service Dealer. 5. Drain the tank and replace the fuel with the proper type.
The engine misses or lacks power.	<ol style="list-style-type: none"> 1. The fuel filter is clogged. 2. The air cleaner is dirty or damaged. 3. The carburetor is out of adjustment. 4. The spark plug is wet, pitted, fouled, or the gap is incorrect. 	<ol style="list-style-type: none"> 1. Clean the fuel tank and replace the fuel filter. 2. Clean or replace the air-cleaner element. 3. Contact an Authorized Service Dealer 4. Install a new, correctly gapped spark plug.
The engine runs and then stops.	<ol style="list-style-type: none"> 1. The fuel cap is not venting. 2. The fuel filter is plugged. 3. The carburetor is out of adjustment. 	<ol style="list-style-type: none"> 1. Clean or replace the fuel cap; check the vent. 2. Clean or replace the fuel filter. 3. Contact an Authorized Service Dealer.
The engine speed is too high.	<ol style="list-style-type: none"> 1. The carburetor is out of adjustment. 	<ol style="list-style-type: none"> 1. Contact an Authorized Service Dealer
The auger turns at idle.	<ol style="list-style-type: none"> 1. The idle speed is too high. 	<ol style="list-style-type: none"> 1. Lower the idle speed.
The auger turns, but has no power.	<ol style="list-style-type: none"> 1. The choke lever is in the ON position. 2. The carburetor is out of adjustment. 3. The powerhead is damaged or broken. 4. The clutch shoes are worn or damaged. 	<ol style="list-style-type: none"> 1. Turn the choke lever to the OFF position after starting the engine. 2. Contact an Authorized Service Dealer. 3. Contact an Authorized Service Dealer. 4. Replace the clutch shoes and spring.
The auger jumps.	<ol style="list-style-type: none"> 1. The blade is damaged. 	<ol style="list-style-type: none"> 1. Replace the blade.
The auger cuts slowly.	<ol style="list-style-type: none"> 1. The blade is dull. 2. The fishtail point is damaged. 	<ol style="list-style-type: none"> 1. Replace the blade. 2. Replace the fishtail point.

Notes:

Notes:



Warranty Terms and Conditions

Product 5-Year Limited Warranty Statement

The Toro Company warrants this product under a five-year limited warranty to be free from defects in the material or workmanship or both for a period not exceeding 60 consecutive months from the date of original purchase by the first retail consumer or first commercial end user. This warranty does not apply to the engine mounted on the product. "Consumer use" means personal recreational use by a retail consumer. "Commercial use" or "commercial application" means all other uses, including use for commercial, income producing, or rental purposes. Once a product has experienced commercial use, it shall thereafter be considered as a commercial use product for the purpose of this warranty. This warranty applies to the original owner who provides a proof of purchase. This warranty is not transferable. The warranty period begins on the date of purchase by the first retail consumer or commercial end user and continues for the 60 month consecutive period thereafter. Any unit used in a commercial application is covered for a period of 90 days after purchase by the first commercial end user. For the warranty to be valid, the product must be registered online within 30 days of purchase, or the warranty card must be filled out and received by Toro within 30 days of purchase. Toro shall not be obligated for transportation charges that result from repair or replacement under the terms of this warranty. Transportation charges are the sole responsibility of the purchaser.

This warranty excludes parts that are worn or damaged due to normal wear such as blades, bearings, belts, tines, debris deflector chain, wheels, tires, tri-hammers, j-hammers, chipper knives, seals, bushings, clutches, pulleys, trimmer line, debris shield, line cutter, grips, shafts, springs and cables. This warranty excludes routine maintenance items such as batteries, filter elements, O-rings, seals, lubricants, tune-ups, rotating parts, accessory parts such as tiller furrowers, edger kits, dethatcher kits, manual canister, battery box, nylon collection bag, collection bag mounts, augers, extensions, shocktops, nylon parts bags and height adjustment heads. These warranties shall not cover damage caused by improper storage and maintenance including but not limited to use of unauthorized parts, failure to perform periodic maintenance as specified in product manual, or repairs performed at unauthorized service centers. These warranties apply only to products which have not been subjected to negligent use, abuse, misuse, alteration or overload which includes but is not limited to running the product dry (without oil), or below minimum oil levels, running engine without proper fuel (straight gasoline or mixed gas), damage to tow bar caused by over cornering, using the equipment for a purpose other than that for which it was designed and manufactured, continued use of product after sudden change in vibration, using the equipment in violation of local codes, ordinances and good trade practices, improper installation, operating the equipment above recommended maximums as stated in the accompanying product and/or engine manuals.

This warranty does not cover events beyond the control of Toro such as accident, acts of God, lightning, and vandalism. This limited warranty applies only to defects in the material or workmanship. There is no other express warranty. Implied warranties, including those of merchantability and fitness for a particular purpose, are limited to one year from purchase, or to the extent permitted by law. All other implied warranties are excluded. Liability for incidental or consequential damages are excluded to the extent exclusion is permitted by law. Toro does not assume, and does not authorize any other person to assume for Toro, any liability in connection with the sale of Toro products. To be at "No Charge," warranty work must be sent directly to and performed by Toro or an Toro Authorized Warranty Service Facility. To obtain warranty service and/or replacement instructions, contact the Toro Customer Service Department at 952-888-8801. If you choose to ship your product to Toro for warranty repair, you must first have prior approval from Toro by calling the Toro Customer Service Department for a return material authorization number (RMA#). Under these circumstances, all items must be shipped prepaid. Toro will, in its discretion, at no charge, repair or replace any defective part to which this warranty applies. Toro retains the right to change models, specifications and price without notice. Toro shall not be obligated to ship any repair or replacement product to any location outside of the United States of America or Canada. Some states and countries do not allow the limitations on how long an implied warranty lasts, or the exclusion or limitation of incidental or consequential damages, so the above limitation may not apply to you. This warranty gives you specific legal rights, and you may also have other rights which vary from state to state and country to country.

California Proposition 65 Warning Information

What is this warning?

You may see a product for sale that has a warning label like the following:



WARNING: Cancer and Reproductive Harm—www.p65Warnings.ca.gov.

What is Prop 65?

Prop 65 applies to any company operating in California, selling products in California, or manufacturing products that may be sold in or brought into California. It mandates that the Governor of California maintain and publish a list of chemicals known to cause cancer, birth defects, and/or other reproductive harm. The list, which is updated annually, includes hundreds of chemicals found in many everyday items. The purpose of Prop 65 is to inform the public about exposure to these chemicals.

Prop 65 does not ban the sale of products containing these chemicals but instead requires warnings on any product, product packaging, or literature with the product. Moreover, a Prop 65 warning does not mean that a product is in violation of any product safety standards or requirements. In fact, the California government has clarified that a Prop 65 warning "is not the same as a regulatory decision that a product is 'safe' or 'unsafe.'" Many of these chemicals have been used in everyday products for years without documented harm. For more information, go to <https://oag.ca.gov/prop65/faqs-view-all>.

A Prop 65 warning means that a company has either (1) evaluated the exposure and has concluded that it exceeds the "no significant risk level"; or (2) has chosen to provide a warning based on its understanding about the presence of a listed chemical without attempting to evaluate the exposure.

Does this law apply everywhere?

Prop 65 warnings are required under California law only. These warnings are seen throughout California in a wide range of settings, including but not limited to restaurants, grocery stores, hotels, schools, and hospitals, and on a wide variety of products. Additionally, some online and mail order retailers provide Prop 65 warnings on their websites or in catalogs.

How do the California warnings compare to federal limits?

Prop 65 standards are often more stringent than federal and international standards. There are various substances that require a Prop 65 warning at levels that are far lower than federal action limits. For example, the Prop 65 standard for warnings for lead is 0.5 µg/day, which is well below the federal and international standards.

Why don't all similar products carry the warning?

- Products sold in California require Prop 65 labelling while similar products sold elsewhere do not.
- A company involved in a Prop 65 lawsuit reaching a settlement may be required to use Prop 65 warnings for its products, but other companies making similar products may have no such requirement.
- The enforcement of Prop 65 is inconsistent.
- Companies may elect not to provide warnings because they conclude that they are not required to do so under Prop 65; a lack of warnings for a product does not mean that the product is free of listed chemicals at similar levels.

Why does Toro include this warning?

Toro has chosen to provide consumers with as much information as possible so that they can make informed decisions about the products they buy and use. Toro provides warnings in certain cases based on its knowledge of the presence of one or more listed chemicals without evaluating the level of exposure, as not all the listed chemicals provide exposure limit requirements. While the exposure from Toro products may be negligible or well within the "no significant risk" range, out of an abundance of caution, Toro has elected to provide the Prop 65 warnings. Moreover, if Toro does not provide these warnings, it could be sued by the State of California or by private parties seeking to enforce Prop 65 and subject to substantial penalties.



Count on it.