



# Rear Roller Brush with Groomer

## Greensmaster<sup>®</sup> 3200 Series

Model No. 04491

## Parts Catalog

### Ordering Replacement Parts

To order replacement parts, please supply: the part number, the quantity, and the description of each part desired.

### Understanding Reference Numbers

Each identified part in an illustration has a reference number. The reference number for a part also appears in the parts list, along with other information about the part.

This catalog uses two special reference number formats, one to indicate parts in a service assembly and another to indicate the quantity of a given part in an illustration.

### Service Assembly Reference Numbers

Parts in service assemblies have reference numbers in the form **a:b**. The **a** represents the reference number of the entire service assembly and the **b** represents a sequential number unique to each part within the service assembly.

For example, a wheel assembly might be identified by reference number **6**, the tire by **6:1**, the valve by **6:2**, and the wheel by **6:3**. When you order the assembly identified by reference number **6**, you receive all parts identified by reference numbers **6:1**, **6:2**, and **6:3**. However, you may also order any part individually.

Reference numbers of this type appear in illustrations and in part lists.

### Reference Numbers Indicating Quantity

In an illustration, if a reference number indicates more than one part, the reference number has the form **nX y**. The **n** represents the quantity of the part, the **X** is the multiplication symbol, and the **y** represents the reference number.

For example, in an illustration, the reference number **2X 37** means that two of the parts identified by reference number **37** are indicated.

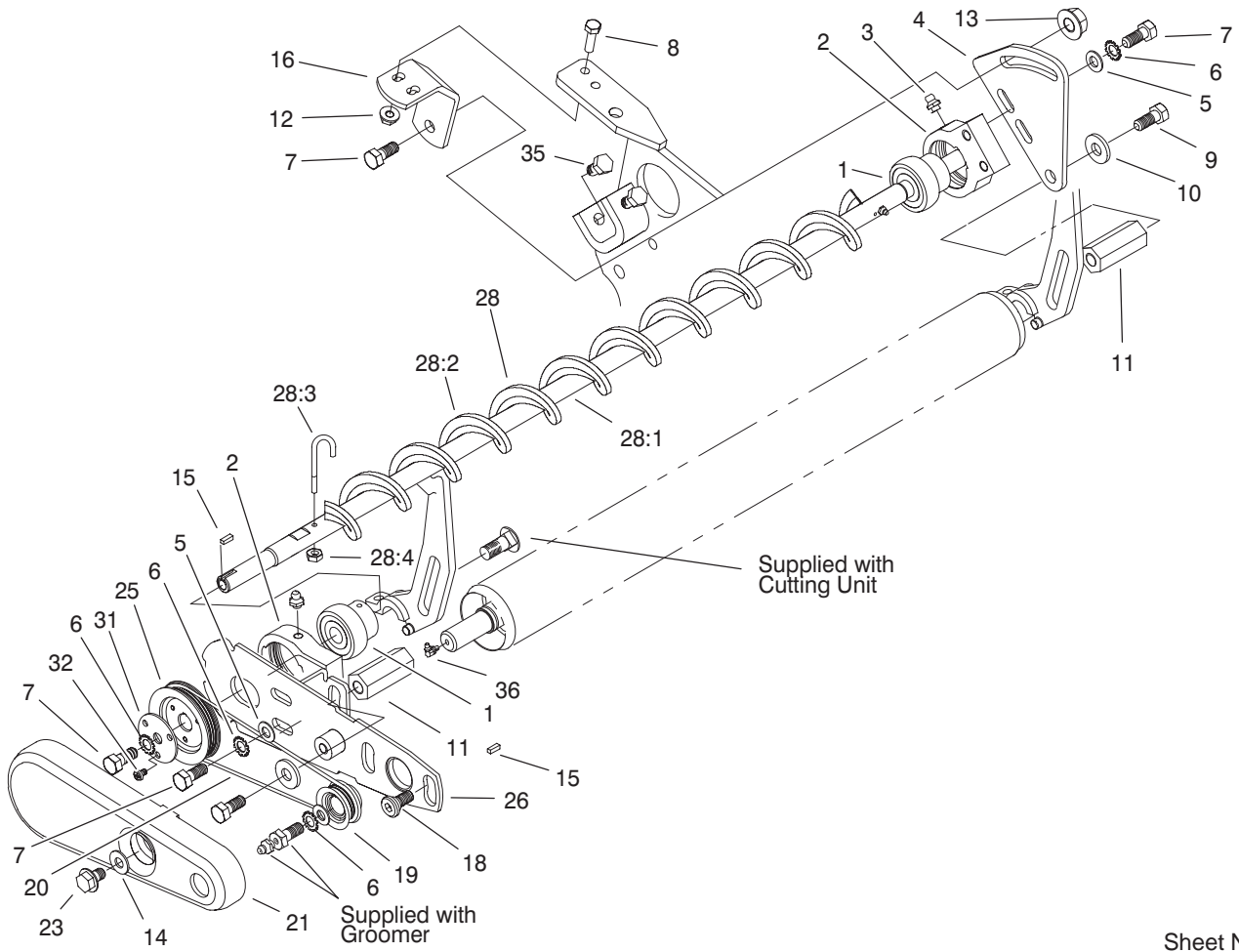

Sheet No.:1

## Roller Brush Assembly

Ref. No.	Part No.	Qty.	Description
1	98-5208	6	Bearing-Roller
2	98-5205	6	Housing-Bearing
3	302-5	6	Fitting-Grease
4	100-6432	3	Plate-Bearing, Adjust
5	3256-2	15	Washer-Flat
6	3255-8	18	Washer-Lock
7	33114-020	18	Screw-HH
8	33113-020	6	Screw-HH
9	33115-020	6	Screw-HH
10	3256-24	6	Washer-Flat
11	98-5220	6	Spacer-Hex, Long
12	33023-00	6	Nut-Lock
13	33004-00	3	Nut-HF
14	87-8640	3	Washer-Flat
15	95-9619	6	Key-Square
16	100-6433	3	Bracket-Support
18	98-5217	6	Bolt-Shoulder
19	98-5232	3	Pulley-Drive
20	98-5213	3	Belt-Drive
21	100-9849	3	Cover-Belt
23	3234-30	3	Screw-HHF
25	98-5231	3	Pulley-Driven
26	100-9848	3	Pivot Plate ASM
28	104-7710	3	Roller Brush ASM
28:1	104-7711	1	Shaft-Brush, Roller
28:2	104-1829	1	Brush-Roller

Ref. No.	Part No.	Qty.	Description
28:3	104-1830	2	Bolt-J
28:4	3296-2	2	Nut-Lock
31	98-5237	3	Washer-Retaining
32	64-7720	9	Screw
35	98-5219	6	Screw-HH
36	302-60	3	Fitting-Grease