



Cup Holder Kit	
260 Series YGT and 300 Series Classic Tractors	
Part No. 105-1400	INSTALLATION INSTRUCTIONS

Loose Parts

Note: Use the chart below to identify parts for assembly.

DESCRIPTION	QTY.	USE
Cup Holder	1	Installing Cup Holder
Screw	4	

Drilling Holes in Tractor Fender

Note: A template must be used to locate the proper location for drilling holes. The template is located in the back of this instruction sheet.

1. Locate and cut out template from the back of this instruction sheet.
2. Take the template and place it on the right side rear fender (Fig. 1).

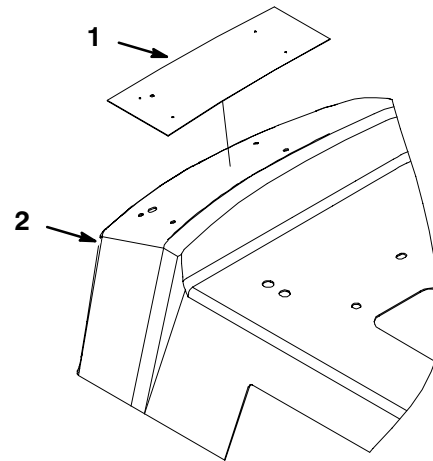

m-5256

Figure 1

1. Template
2. Right rear fender

3. Position the template so front and outside edges, of the template, are positioned just where the fender top surface starts to curve down (Fig. 2).

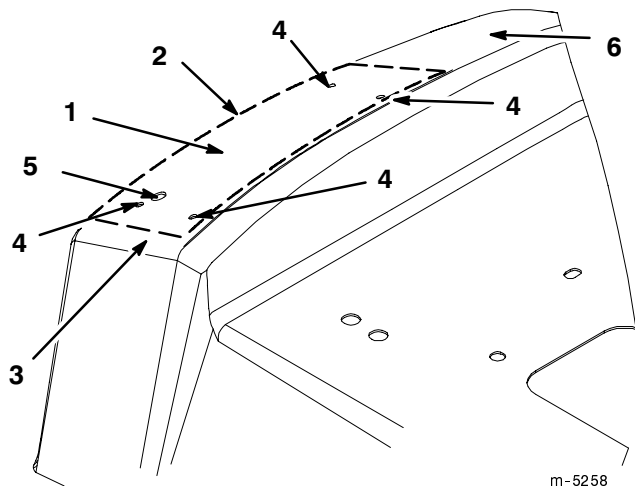

Figure 2

- | | |
|-----------------|-----------------------|
| 1. Template | 4. 7/32 in. hole |
| 2. Outside edge | 5. 3/8 in. hole |
| 3. Front edge | 6. Fender top surface |

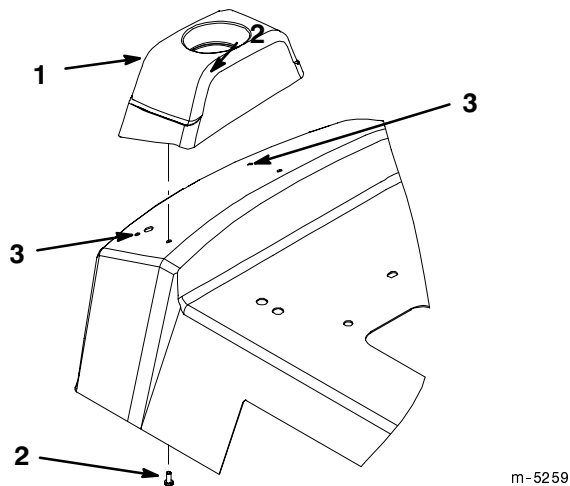

Figure 3

- | | |
|---------------|------------------|
| 1. Cup holder | 3. Drilled holes |
| 2. Screw | |

4. Tape template to rear fender.
5. Mark the location for all five holes.
6. Remove paper template.
7. Using a 7/32 in. drill bit, drill four holes into the fender as located on the template (Fig. 2).
8. Using a 3/8 in. drill bit, drill one hole into the fender as located on the template (Fig. 2).

Installing Cup Holder

1. Place cup holder onto tractor fender and install with screws as shown in figure 3.

Template

