



ProLine H800 Rotary Mower

Model No. 31051—Serial No. 321000000 and Up

Setup Instructions

Setup

Loose Parts

Use the chart below to verify that all parts have been shipped.

Procedure	Description	Qty.	Use
1	Mower deck	1	Remove the machine from the crate.
	Machine	1	
	Hopper door	1	
2	Flat washer	6	Install the hopper door.
	Bolt	2	
	Locknut	2	
3	Hook	1	Install the latch.
	Spacer	1	
	Long bolt	2	
	Short bolt	1	
	Flat washer	3	
	Rod connector	1	
	Spring	1	
	Bushing	2	
	Flange nut	3	
Locknut	2		
4	Rear bumper	1	Install the rear bumper.
	Bolt	4	
	Flat washer	8	
	Locknut	4	
	Cable ties	4	
5	Front light assembly	1	Install the front lights.
	Knob	2	
6	No parts required	—	Position the beacon light.
7	Warning decal	1	Install the decals.
	Spark arrestor/Prop 65 decal	1	
	Diesel fuel decal	1	
8	No parts required	—	Completing the setup.

Note: Determine the left and right sides of the machine from the normal operating position.



1

Removing the Machine from the Crate

Parts needed for this procedure:

1	Mower deck
1	Machine
1	Hopper door

Procedure

1. Remove the 4 planks that attach the mower-deck crate to the traction-unit crate.
2. Remove the mower deck crate (Figure 1).
3. Remove the hopper door from the crate (Figure 1).
4. Remove the front panel, plastic bags, and other packaging material.
5. Remove all the packaged machine components attached to the pallet.
6. Remove the wood over the seat that is used to support the hopper door.
7. Remove the rear bumper and the light assembly.
8. Remove the wooden blocks from the wheels and the steel hooks.
9. Charge and connect the battery; refer to the *Operator's Manual*.
10. Remove the machine from the crate (Figure 1).

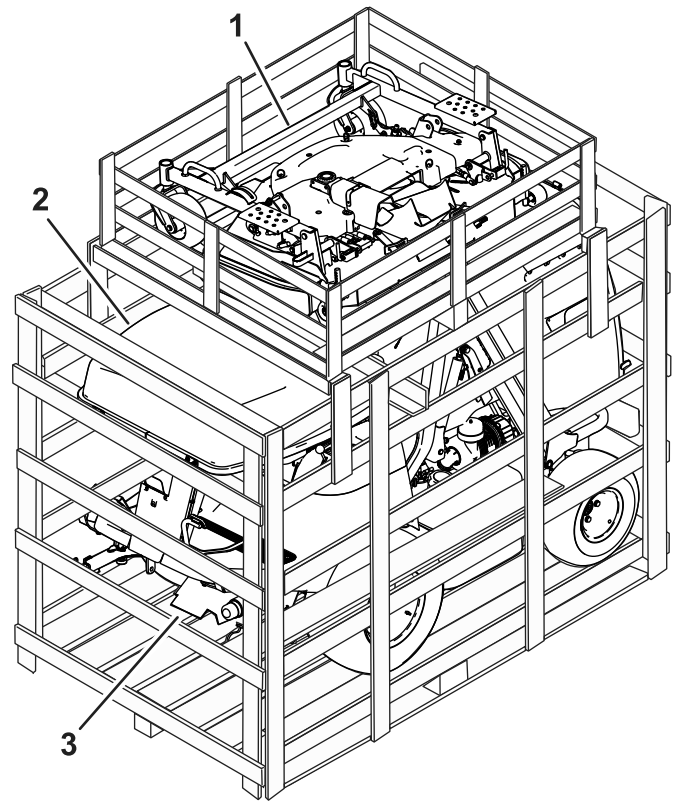

Figure 1

1. Mower deck
2. Hopper door
3. Machine

g315990

2

Installing the Hopper Door

Parts needed for this procedure:

6	Flat washer
2	Bolt
2	Locknut

Procedure

1. Remove the hardware from the brackets on the hopper.
2. Install the hopper door to the hopper with the previously removed hardware; refer to [Figure 2](#).

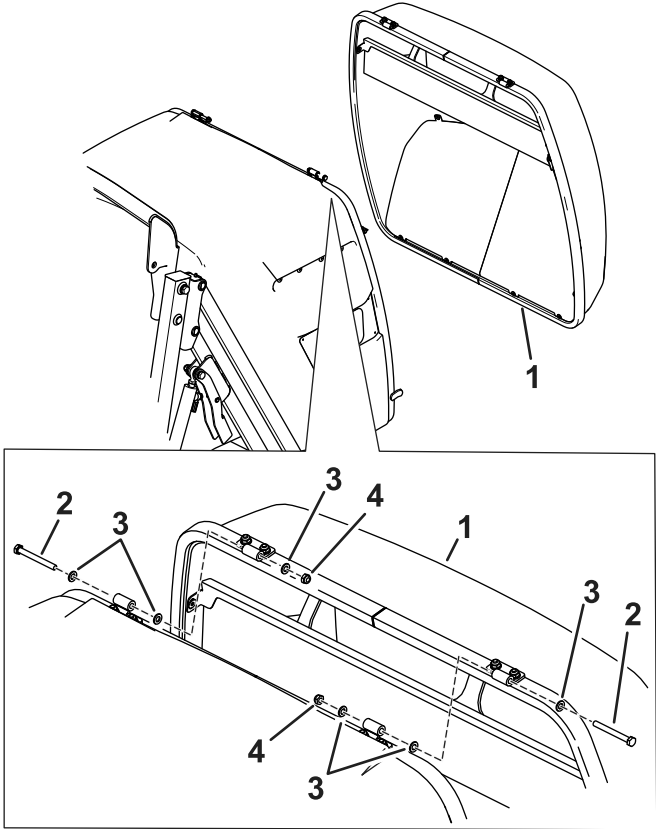

Figure 2

g315991

- | | |
|----------------|------------|
| 1. Hopper door | 3. Washer |
| 2. Bolt | 4. Locknut |

3

Installing the Latch

Parts needed for this procedure:

1	Hook
1	Spacer
2	Long bolt
1	Short bolt
3	Flat washer
1	Rod connector
1	Spring
2	Bushing
3	Flange nut
2	Locknut

Procedure

1. Install the hook and spacer to the hopper with a long bolt, flat washer, flange nut, spring, and locknut ([Figure 3](#)).

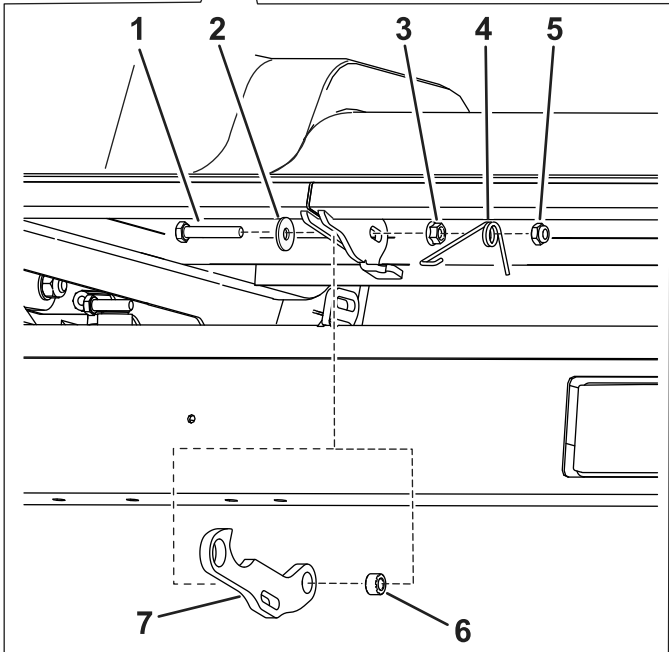
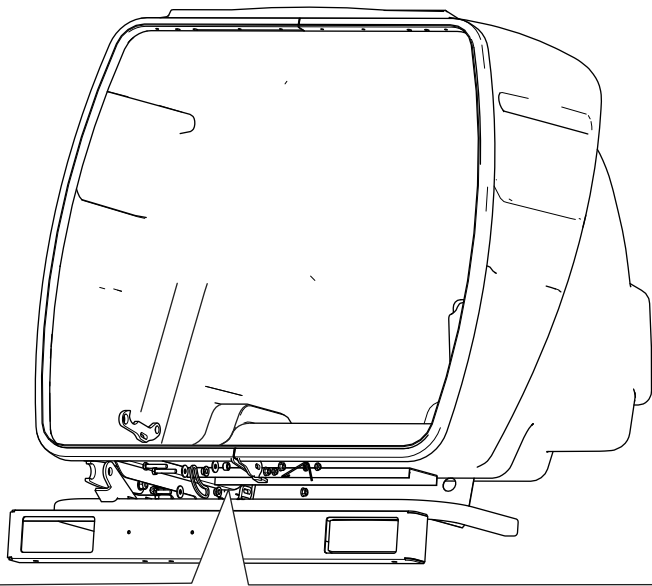

Figure 3

g315989

- | | |
|----------------|------------|
| 1. Long bolt | 5. Locknut |
| 2. Flat washer | 6. Spacer |
| 3. Flange nut | 7. Hook |
| 4. Spring | |

2. Install the rod connector to the hook with a long bolt, flat washer, bushing, flange nut, and locknut (Figure 4).

Note: Ensure that the locknut is not fully installed onto the bolt. The space between the flange nut and locknut is used for the spring (Figure 6).

3. Install the rod connector to the hook with a short bolt, flat washer, bushing, and locknut. (Figure 4).

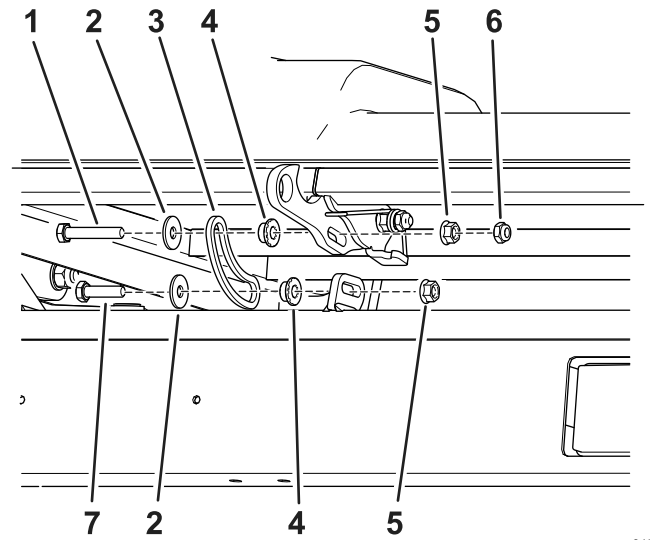

Figure 4

g315987

- | | |
|------------------|---------------|
| 1. Long bolt | 5. Flange nut |
| 2. Flat washer | 6. Locknut |
| 3. Rod connector | 7. Short bolt |
| 4. Bushing | |

4. Check the gap between the hook and the closed hopper door. Ensure that the gap is 2 mm (1/16 inch) and adjust if necessary (Figure 5).

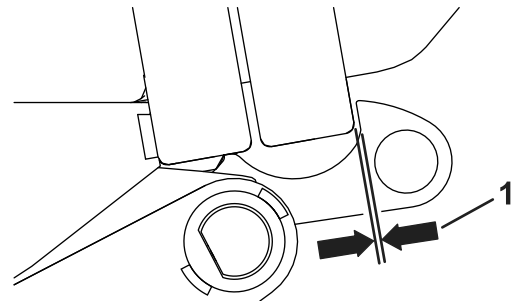

Figure 5

g316170

1. 2 mm (1/16 inch) gap

5. Install the spring ends as shown in Figure 6.

4

Installing the Rear Bumper

Parts needed for this procedure:

1	Rear bumper
4	Bolt
8	Flat washer
4	Locknut
4	Cable ties

Procedure

1. Remove the hardware from the rear bumper (Figure 7).
2. Install the rear bumper under the hopper with the previously removed hardware (Figure 7).
3. Connect the wire harness to the machine harness.
4. Verify that the left and right turn lights are hooked up correctly by using the turn signal. If needed, change the connections.
5. Use the cable ties to fasten the wire harness to the rear bumper.

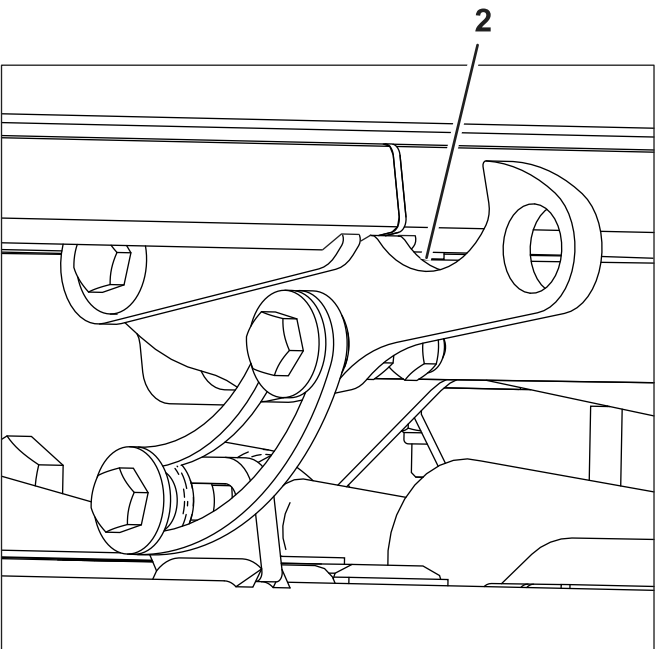
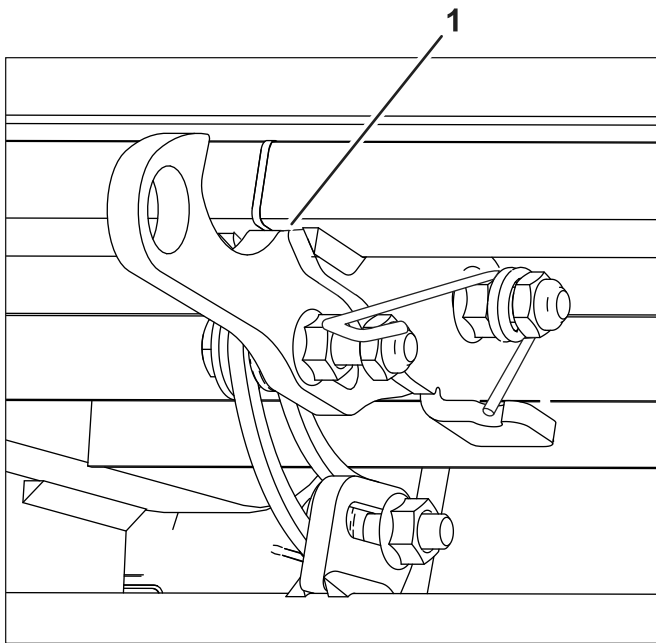

g315988

Figure 6
Hook installed

1. Right side

2. Left side

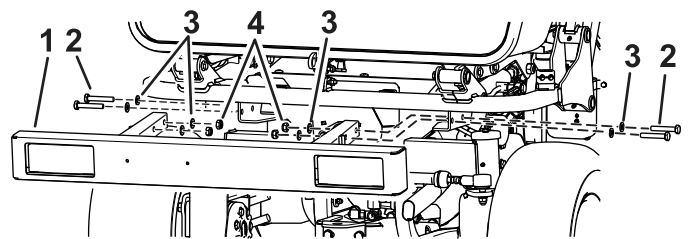
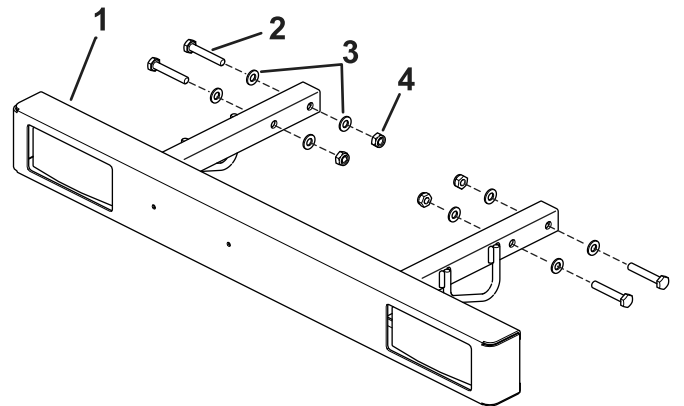

g316095

Figure 7

1. Rear bumper

3. Washer

2. Bolt

4. Locknut

5

Installing the Front Lights

Parts needed for this procedure:

1	Front light assembly
2	Knob

Procedure

1. Install the front lights onto the machine brackets by using the slots in the brackets ([Figure 8](#)).
2. Tighten the knobs ([Figure 8](#)).
3. Connect the wire harness to the machine harness.

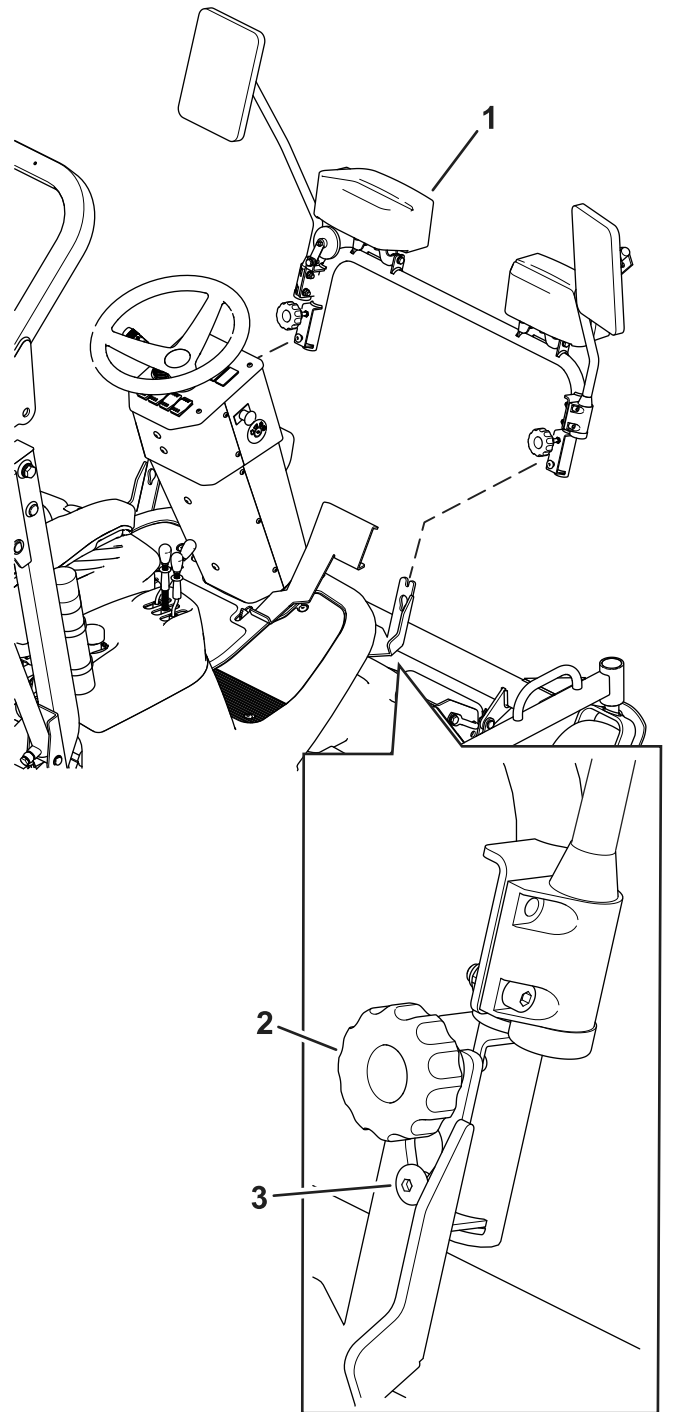

Figure 8

g316094

1. Front lights
2. Knob installed
3. Screw head in the slot

6

Positioning the Beacon Light

No Parts Required

Procedure

1. Raise the rollbar; refer to the *Operator's Manual*.
2. Rotate the beacon light to the upright position and secure the fasteners.

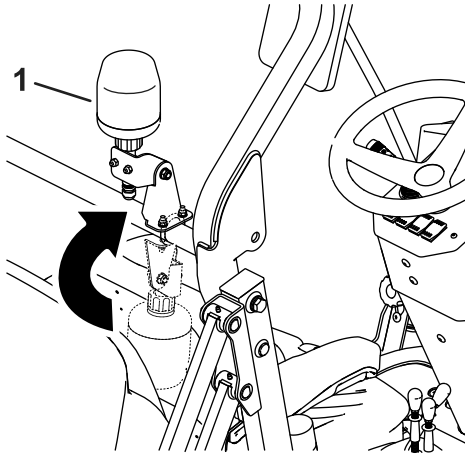

Figure 9

1. Operating position

7

Installing the Decals

Parts needed for this procedure:

1	Warning decal
1	Spark arrestor/Prop 65 decal
1	Diesel fuel decal

Procedure

Note: Ensure the decals are installed at the time of sale or shown to the public for the countries listed in the table on page 8.

Install the warning decal, spark arrestor decal, and the diesel fuel decal (Figure 10).

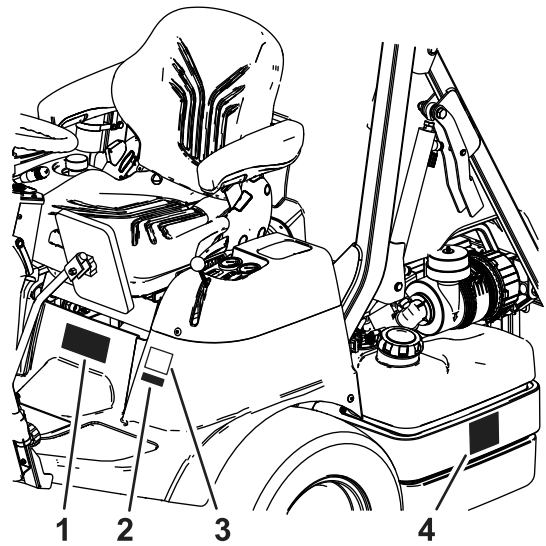

Figure 10

g316208

1. Warning decal—install over the existing decal
2. Spark-arrestor decal
3. Existing decal
4. Diesel fuel decal

8

Completing the Setup

No Parts Required

Procedure

Complete the setup instructions that are in the *Operator's Manual*.

Countries

ISO	Language
AI	Anguilla
AG	Antigua and Barbuda
AR	Argentina
BS	Bahamas
BB	Barbados
Bz	Belize
BM	Bermuda
BO	Bolivia
VG	British Virgin Islands
BN	Brunei
BU	Burma (Myanmar)
CA	Canada
KY	Cayman Islands
CO	Colombia
CR	Costa Rica
DM	Dominica
EC	Ecuador
EG	Egypt
FJ	Fiji
GD	Grenada

ISO	Language
GU	Guam
GT	Guatemala
GY	Guyana
HT	Haiti
IN	India
IL	Israel
JM	Jamaica
LB	Lebanon
MY	Malaysia
MV	Maldives
MU	Mauritius
MX	Mexico
UM	Minor Outlying Islands
MS	Montserrat
MP	Northern Mariana Islands
OM	Oman
Pa	Panama
PY	Paraguay
PE	Peru
PH	Philippines

ISO	Language
PR	Puerto Rico
LC	Saint Lucia, Saint Kitts and Nevis
VC	Saint Vincent, Grenadines
AS	Samoa, American
SG	Singapore
LK	Sri Lanka
SR	Suriname
TW	Taiwan
TH	Thailand
TT	Trinidad and Tobago
TN	Tunisia
TC	Turks and Caicos Islands
AE	United Arab Emirates
US	United States
VI	U.S. Virgin Islands
UY	Uruguay
VE	Venezuela
VN	Vietnam