



MODEL NO. 03706 - 210000001 & UP  
 MODEL NO. 03707 - 210000001 & UP

OPERATOR'S  
 MANUAL

**REELMASTER® 4000 D**  
 TRACTION UNIT

To understand this product, and for safety and optimum performance, read this manual before starting the engine. Pay special attention to **SAFETY INSTRUCTIONS** highlighted by this symbol.



It means **CAUTION, WARNING or DANGER** - personal safety instruction. Failure to comply with the instruction may result in personal injury.



The REELMASTER 4000 D conforms to the American National Standards Institute's safety standards for riding mowers when rear tires are filled with calcium chloride and two rear wheel weight kits (Part No. 11-0440) are installed.

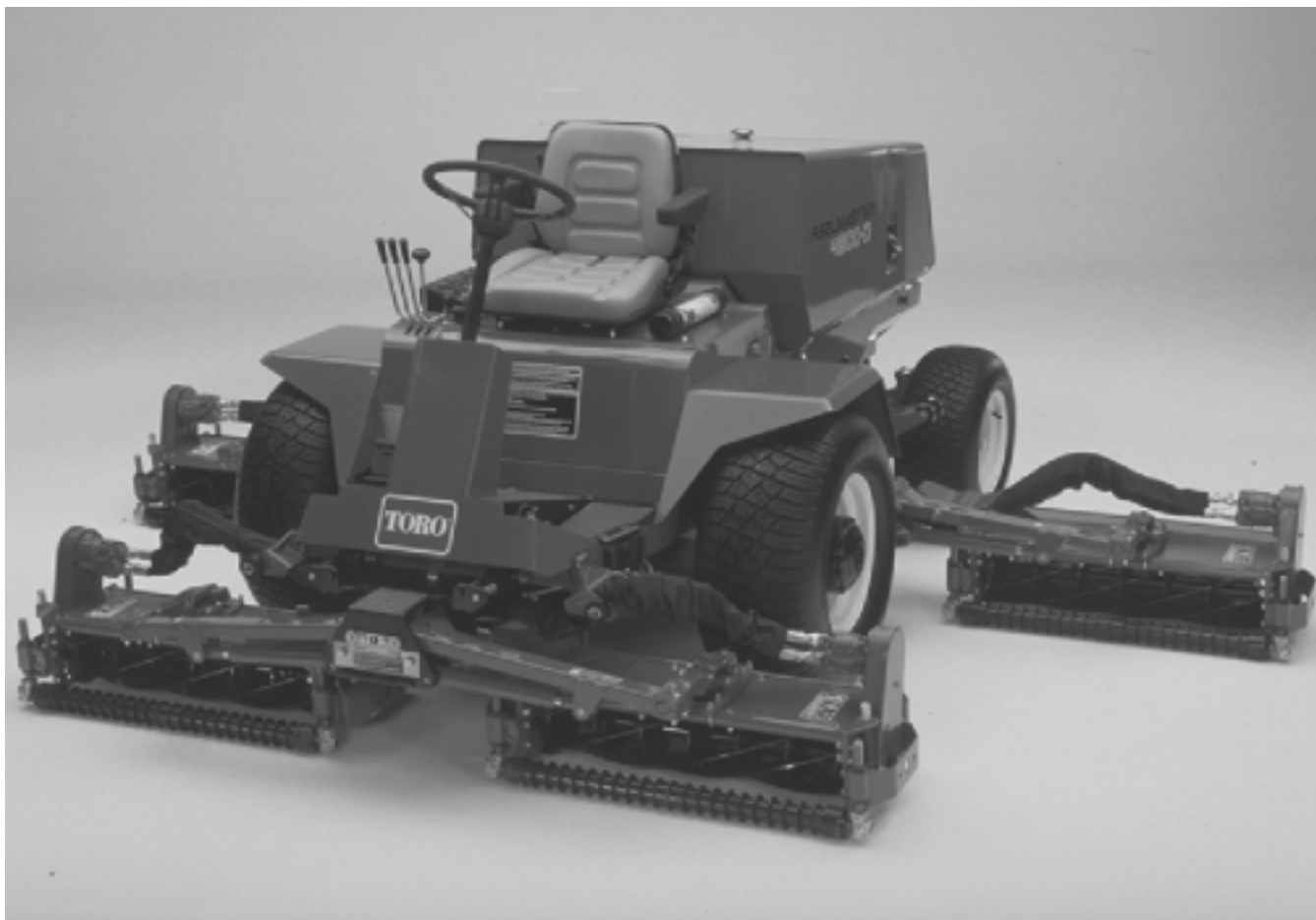

# FOREWORD

This operator's manual has instructions on safety, proper set-up and operation, adjustments and maintenance. Therefore, anyone involved with the product, including the operator, should read and understand this manual.

Major sections are:

- Safety Instructions
- Specifications
- Before Operating
- Know Your Controls
- Operating Instructions
- Maintenance
- Schematics

This manual emphasizes safety, mechanical and general product information. DANGER, WARNING and CAUTION identify safety messages. Whenever the triangular safety alert symbol appears, understand the safety message that follows. For complete safety instructions, read pages 4 – 5. IMPORTANT highlights special mechanical information and NOTE emphasizes general product information worthy of special attention.

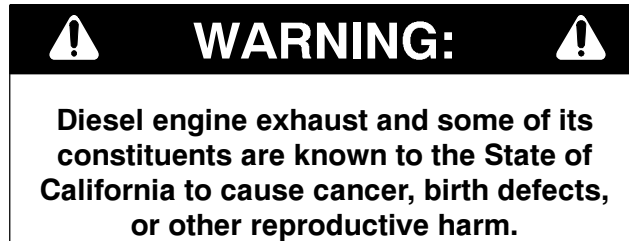

## SPARK ARRESTER

Because in some areas there are local, state or federal regulations requiring that a spark arrestor muffler be used on the engine of this mower, a spark arrestor muffler is available as an option. If a spark arrestor muffler is required, order one of the following parts from your local Authorized Toro Distributor.

- (1) 74-2900 Spark Arrestor Muffler (Two wheel drive model only)
- (1) 92-6074 Spark Arrestor Muffler (Four wheel drive model only)

When the mower is used or operated on any California forest, brush or grass covered land, a properly operating spark arrester must be attached to the muffler. The operator is violating state law, Section 442 Public Resources Code if a spark arrester is not used.

Whenever you have questions or need service, contact your local authorized Toro Distributor. In addition to having a complete line of accessories and professional turf care service technicians, the distributor has a complete line of genuine TORO replacement parts to keep your machine operating properly. Keep your TORO all TORO. Buy genuine TORO parts and accessories.

# TABLE OF CONTENTS

<b>SAFETY INSTRUCTIONS</b> .....	<b>4–5</b>	<b>MAINTENANCE</b> .....	<b>23–29</b>
<b>SAFETY AND INSTRUCTION DECALS</b> .....	<b>6–8</b>	General Air Cleaner Maintenance .....	23
<b>SPECIFICATIONS</b> .....	<b>9–10</b>	Servicing Air Cleaner .....	23
<b>BEFORE OPERATING</b> .....	<b>11–12</b>	Engine Oil and Filter .....	24
Check Engine Oil .....	11	Fuel System .....	24
Check Cooling System .....	11	Engine Cooling System .....	25
Fill Fuel Tank .....	12	Alternator Belt .....	25
Check Hydraulic System .....	12	Battery Care .....	26
Check Reel to Bedknife Contact .....	12	Adjusting Hand Brake & Traction Switches ..	26
Check Tire Pressure .....	12	Adding Hydraulic Oil .....	26
Rear Ballast .....	12	Draining Water From Hydraulic Reservoir ...	26
<b>KNOW YOUR CONTROLS</b> .....	<b>13–16</b>	Changing Hydraulic Oil .....	27
<b>OPERATING INSTRUCTIONS</b> .....	<b>16–20</b>	Replacing Hydraulic Filter .....	27
Starting and Stopping .....	16	Replacing Hydraulic System Breather .....	28
Priming Fuel System .....	16	Checking Hydraulic Lines and Hoses .....	28
Checking Warning Indicator Lights .....	17	Hydraulic System Test Ports .....	28
Checking Interlock System .....	17	Rear Wheel Toe-In .....	29
Pushing or Towing Traction Unit .....	17	Checking Planetary Gear Drive .....	29
Operating Characteristics .....	18	Engine Valve Clearance .....	29
Cutting Charts .....	20	<b>ELECTRICAL SCHEMATIC</b> .....	<b>30</b>
<b>LUBRICATION</b> .....	<b>21</b>	<b>HYDRAULIC SCHEMATIC</b> .....	<b>31</b>
<b>MAINTENANCE CHART &amp; CHECKLIST</b> .....	<b>22</b>	<b>MAINTENANCE SCHEDULE</b> .....	<b>32</b>
		<b>PRODUCT IDENTIFICATION</b> .....	<b>33</b>
		<b>WARRANTY</b> .....	<b>BACK COVER</b>



# SAFETY INSTRUCTIONS

Improper use or maintenance by the operator or owner of the machine can result in injury. Reduce the potential for any injury by complying with the following safety instructions.

## BEFORE OPERATING

1. Read and understand the contents of the traction unit and cutting unit operator's manuals before operating the machine. To get replacement manuals, send complete model and serial number to:

The Toro Company  
8111 Lyndale Avenue South  
Minneapolis, MN 55420–1196

2. Never allow children to operate the machine or adults to operate it without proper instruction.

3. Become familiar with the controls and know how to stop the machine and engine quickly.

4. Keep all shields, safety devices and decals in place. If a shield, safety device or decal is damaged, repair or replace it before operating the machine.

5. Always wear substantial shoes. Do not operate machine while wearing sandals, tennis shoes, sneakers or when barefoot. Do not wear loose fitting clothing that could get caught in moving parts and possibly cause personal injury.

6. Wearing safety glasses, safety shoes, long pants and a helmet is advisable and required by some local ordinances and insurance regulations.

7. Make sure the work area is clear of objects which might be picked up and thrown by the reels.

8. Do not carry passengers on the machine. Keep everyone, especially children and pets, away from the areas of operation.

9. Since diesel fuel is highly flammable, handle it carefully:

- A. Use an approved fuel container.
- B. Do not remove fuel tank cap while engine is hot or running.
- C. Do not smoke while handling fuel.
- D. Fill fuel tank outdoors and only to within an inch (25 mm) from the top of the tank, not the filler neck. Do not overfill.
- E. Wipe up any spilled fuel.

## WHILE OPERATING

10. Do not run engine in a confined area without adequate ventilation. Exhaust is hazardous and could be deadly.

11. Sit on the seat when starting and operating the machine.

12. Check interlock switches daily for proper operation. If a switch fails, replace it before operating the machine. The interlock system is for your protection, so do not bypass it. Replace all interlock switches every two years.

13. This product may exceed noise levels of 85 dB(A) at the operator position. Ear protectors are recommended for prolonged exposure to reduce the potential of permanent hearing damage.

14. Before starting the engine each day, check indicator lights, warning buzzer and signal lights to assure proper operation.

15. Pay attention when using the machine. To prevent loss of control:

- A. Mow only in daylight or when there is good artificial light.
- B. Watch for holes or other hidden hazards.
- C. Be extremely careful when operating close to sand traps, ditches, creeks, steep hillsides or other hazards.
- D. Reduce speed when making sharp turns. Avoid sudden stops and starts. Use ground speed limiter lever to set pedal travel so excessive ground speed will be avoided during mowing and transport.
- E. Look to the rear to assure no one is behind the machine before backing up.
- F. Watch for traffic when near or crossing roads. Always yield the right-of-way.
- G. Reduce speed when driving downhill.

16. Keep hands, feet and clothing away from moving parts and the reel.

17. Traverse slopes carefully. Do not start or stop suddenly when traveling uphill or downhill.

18. Operator must be skilled and trained in how to drive on hillsides. Failure to use caution on slopes or hills may cause loss of control and vehicle to tip or roll possibly resulting in personal injury or death.

19. When operating 4 wheel drive machine, always use the seat belt and ROPS together and have seat pivot retaining pin installed.

20. If engine stalls or loses traction and cannot make it to the top of a slope, do not turn machine around. Always back slowly straight down the slope.

21. Raise cutting units and latch them securely in transport position before driving from one work area to another.

22. Do not touch engine, muffler or exhaust pipe while engine is running or soon after it is stopped. These areas could be hot enough to cause burns.



## SAFETY INSTRUCTIONS

**23.** If cutting unit strikes a solid object or vibrates abnormally, stop immediately, turn engine off, set parking brake and wait for all motion to stop. Inspect for damage. If reel or bedknife is damaged, repair or replace it before operating. Do not attempt to free blocked cutting unit by moving Mow/Backlap lever rapidly between FORWARD and BACKLAP. Damage to hydraulic system may result. Lever should easily return and hold in the STOP position.

**24.** Before getting off the seat:

- A. Disengage cutting units and wait for reels to stop.
- B. Move traction pedal to neutral.
- C. Set parking brake.
- D. Stop engine and remove key from switch.
- E. Do not park on slopes unless wheels are chocked or blocked.

**25.** The optional TORO tow bar (Part No. 58–7020) is for emergency towing only. Use only the special tow bar if it becomes necessary to tow machine. Use trailer for normal transport. Refer to page 18 for towing procedure.

### MAINTENANCE

**26.** Before servicing or making adjustments, stop engine and remove key from the switch.

**27.** Assure entire machine is properly maintained and in good operating condition. Make sure all nuts, bolts and screws are tight.

**28.** Frequently check all hydraulic line connectors and fittings. Assure all hydraulic hoses and lines are in good condition before applying pressure to the system.

**29.** Keep body and hands away from pin hole leaks or nozzles that eject high pressure hydraulic fluid. Use cardboard or paper to find hydraulic leaks. Hydraulic fluid escaping under pressure can penetrate skin and cause injury. Fluid accidentally injected into the skin must be surgically removed within a few hours by a doctor or gangrene may occur.

**30.** Before any hydraulic system maintenance, stop engine and lower cutting units to the ground so all pressure is relieved.

**31.** For major repairs or other assistance, contact your local Toro Distributor.

**32.** To reduce potential fire hazard, keep engine area free of excessive grease, grass, leaves and dirt. Clean protective screen on back of engine frequently.

**33.** If engine must be running to perform maintenance or an adjustment, keep hands, feet, clothing and other parts of the body away from cutting units and other moving parts. Keep everyone away.

**34.** Do not overspeed the engine by changing governor setting. Maximum engine speed is 2500 rpm + or – 100 rpm. To assure safety and accuracy, have an Authorized Toro Distributor check maximum engine speed.

**35.** Shut engine off before checking or adding oil to the crankcase.

**36.** Disconnect battery before servicing the machine. If battery voltage is required for troubleshooting or test procedures, temporarily connect the battery.

**37.** Toro recommends that two people be used to backlap reels. Each person has specific duties and you must communicate with one another.

**38.** For optimum performance and safety, use genuine Toro replacement parts and accessories. Replacement parts and accessories made by other manufacturers could be dangerous and may void the product warranty of The Toro Company.

### SOUND PRESSURE LEVEL

This unit has an equivalent continuous A-weighted sound pressure at the operator ear of: 90 dB(A), based on measurements of identical machines per Directive 84/538/EEC and amendments.

### VIBRATION LEVEL

#### Hand-Arm

This unit does not exceed a vibration level of 2.5 m/s<sup>2</sup>, at the hands based on measurements of identical machines per ISO 5349 procedures.

#### WHOLE BODY

This unit does not exceed a vibration level of 0.5 m/s<sup>2</sup> at the posterior based on measurements of identical machines per ISO 2631 procedures.



# SAFETY AND INSTRUCTION DECALS

The following safety and instruction decals are installed on the traction unit. If any become damaged, replace them. Decals are listed in your Parts Catalog. Order replacements from your Authorized TORO Distributor.

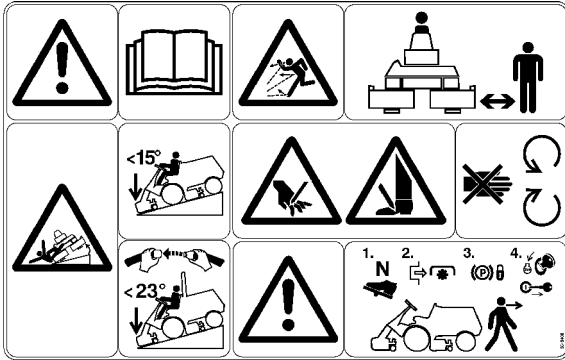

**ON PANEL IN FRONT OF OPERATOR'S SEAT  
(Part No. 93-9408)**

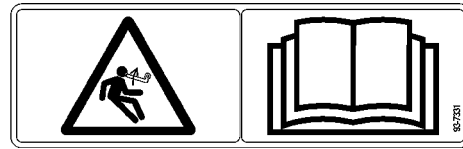

**ON LIFT ARMS  
(Part No. 93-7331)**

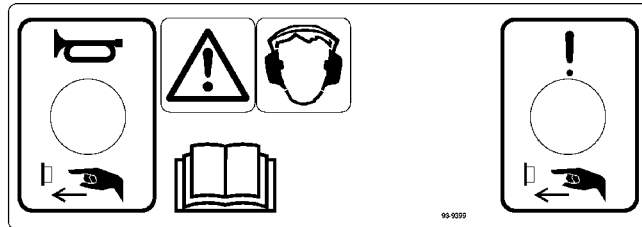

**ON STEERING CONSOLE  
(Part No. 93-9399)**

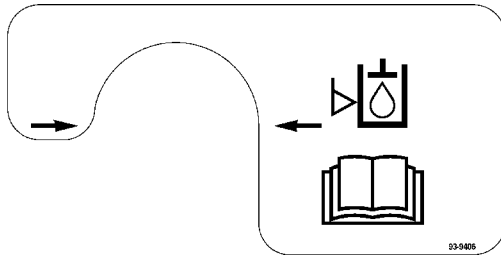

**ON LEFT SIDE OF MACHINE  
(Part No. 93-9406)**

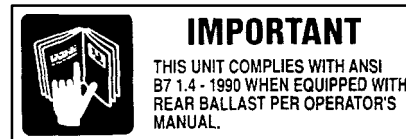

**ON FRAME ABOVE RIGHT REAR WHEEL  
(Part No. 88-6700)**

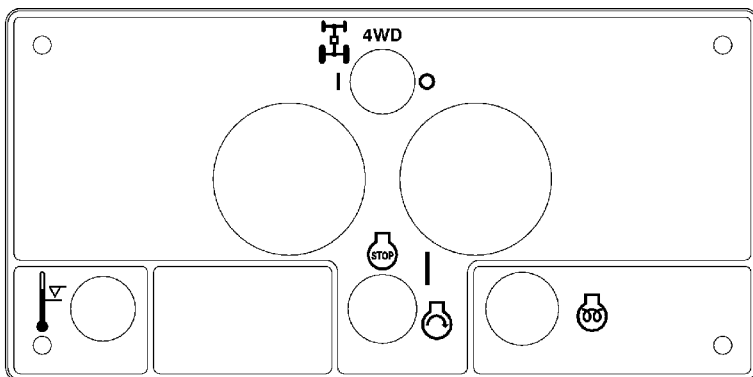

**ON RIGHT CONTROL PANEL  
(Part No. 98-3830)**

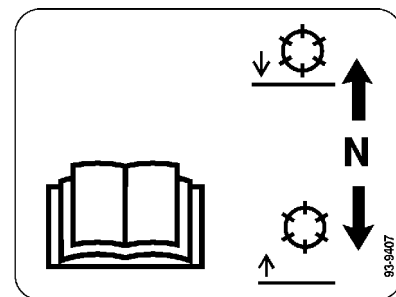

**NEXT TO LIFT LEVERS  
(Part No. 93-9407)**



# SAFETY AND INSTRUCTION DECALS

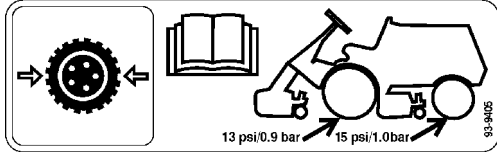

**ON FRAME ABOVE REAR WHEELS**  
(Part No.93-9405)

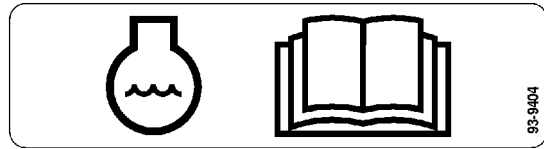

**NEAR RADIATOR FILL CAP**  
(Part No. 93-9404)

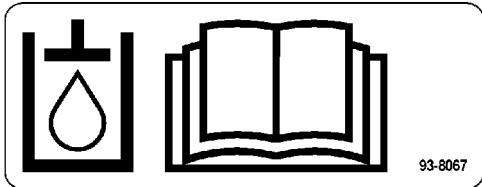

**UNDER SEAT NEAR OIL FILL CAP**  
(Part No. 93-8067)

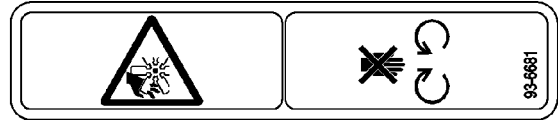

**ON FAN SHROUD**  
(Part No. 93-6681)

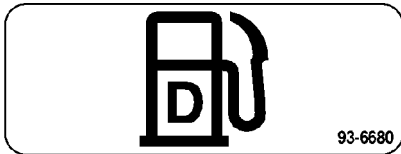

**NEAR FUEL TANK FILL CAP**  
(Part No. 93-6680)



**ON CUTTING UNIT**  
(Part No. 76-8760)

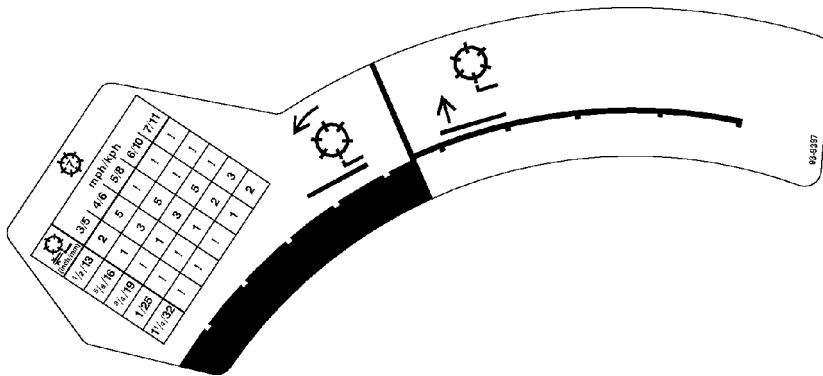

**NEXT TO TRACTION PEDAL ON STEERING CONSOLE**  
(Part No. 93-9397)



**ON RADIATOR CAP**  
(Part No. 59-8440)



# SAFETY AND INSTRUCTION DECALS

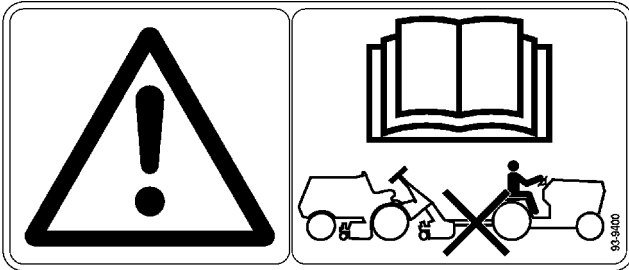

**ON FRONT CARRIER & TOW BAR**  
(Part No. 93-9400)

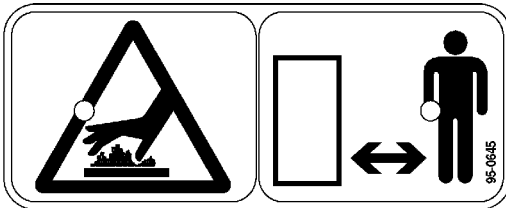

**ON EXHAUST SHIELD**  
(Part No. 95-0645)

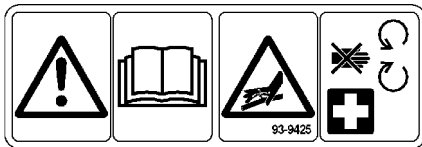

**ON FRONT ACCESS PANEL**  
(Part No. 93-9425)

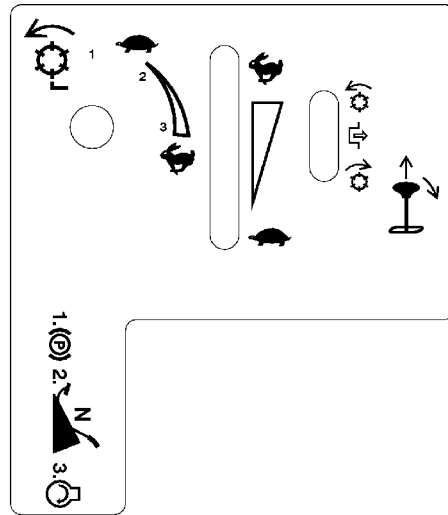

**ON RIGHT CONTROL PANEL**  
(Part No. 93-9402)



# SPECIFICATIONS

**Engine:** Kubota, four-cycle, four cylinder, 134 cu-in. displacement, water cooled diesel engine. Rated 40 hp @ 2300 rpm, 23:1 compression ratio. Low idle – 1200 rpm, high idle – 2500 rpm. Injection Timing – 17–18° BTDC. Oil capacity is 8 qt. (7.6 L) with filter.

**Cooling System:** Capacity is 3.7 gal. (14 L) of 50/50 mixture of ethylene glycol anti-freeze.

**Fuel System:** Capacity is 15 gal. (56.8 L) of #2 diesel fuel.

**Hydraulic System:** Reservoir capacity is 9.3 gal. (35.2 L) and total system capacity is 18.2 gal. (69 L). Replaceable breather element. Replaceable spin-on filter element.

**Traction System:** Ground speed is 0–12.5 mph (0–20 km/h).

**Cutting Unit Drive System:** Adjustable reel speed to match clip to ground speed. Backlap reel speed is 385 rpm.

**Seat:** Adjusts 6 in. (15.2 cm) forward and backward. Adjustable backrest and three-positions for operator weight. Integral seat switch at rear of bottom seat cushion.

**Diagnostic System:** Test ports for traction system, cutting unit drive system, lift/counterbalance, lift/relief, steering circuits and charge pressure are located near individual components.

**Steering System:** Automotive type, full power.

**Brakes:** Hand brake automatically locks traction linkage in neutral. With traction motor wheel locks engaged, twin disc brakes provide positive, emergency braking.

**Electrical System:** 12 volt, 66 amp hour (DIN) battery and 40 amp alternator. Negative ground.

**Interlock System:** Designed to stop engine if operator gets off seat while cutting unit drive lever is either in forward or reverse. Prevents engine from starting unless parking brake is engaged, traction pedal is in neutral and cutting units are disengaged. Low hydraulic oil level and high engine temperature protection systems stop engine from running.

## Warning Systems:

- Water in fuel
- Hydraulic oil filter
- Engine coolant temperature
- Engine oil pressure
- Voltage Indicator
- Air Cleaner Clogged
- Hydraulic oil temperature
- Hydraulic oil level

## General Specifications (approx.):

### Width-of-Cut :

5 Cutting Units	137 in. (348 cm)
4 Cutting Units	110 in. (279 cm)
3 Cutting Units	83 in. (211 cm)
1 Cutting Unit	29 1/2 in. (75 cm)

### Overall Width:

Cutting Units Raised	91 1/2 in. (232 cm)
Cutting Units Down	147 in. (373 cm)

### Overall Length:

110 in. (282 cm)

### Height:

55 1/2 in. (141 cm)

### Height w/ROPS:

82 in. (208 cm)

### Ground Clearance:

approx. 7 in. (17.8 cm)

### Recommended Height-of-Cut:

5 Blade Cutting Unit:	1 – 3 in. (25 – 76 mm)
7 Blade Cutting Unit:	3/8 – 1 3/4 in. (9.5 – 45 mm)
11 Blade Cutting Unit:	3/8 – 3/4 in. (9.5 – 19 mm)

### Wheel Tread:

53 in. (135 cm)

### Wheel Base:

57 in. (145 cm)

### Operating Circle:

60 in. (152 cm)

### Dry Weight:

4360 lbs. (1717 kg)

### Reel Speed:

800 – 1000 rpm

Note: 1200 rpm is attainable with a special coupler.

### Clip (variable to match conditions):

5 Blade Cutting Unit:	.176 in. per mph (.352 in. at 2 mph – 1.32 in. at 7.5 mph)
7 Blade Cutting Unit:	.126 in. per mph (.252 in. at 2 mph – .945 in. at 7.5 mph)
11 Blade Cutting Unit:	.080 in. per mph (.16 in. at 2 mph – .600 in. at 7.5 mph)

### Fluids:

#### Engine Oil:

See page 11 for specifications

#### Diesel Fuel:

#2

#### Cooling System:

50/50 Water & Anti-Freeze

#### Hydraulic Oils (Interchangeable):

Mobil DTE 26/Shell Tellus 68 Equivalent\*

\*Equivalent Hydraulic Oils (Interchangeable)

Mobil	DTE 15 M
Amoco	Rykon Oil #68
Conoco	Super Hydraulic Oil 68
Exxon	Nuto H 68
Kendall	Kenoil R & O AW 68
Pennzoil	Penreco 68
Phillips	Magnus A 68
Standard	Energol HLP 68
Sun	Sunvis 831 WR
Union	Unax AW 68

# SPECIFICATIONS

## OPTIONAL EQUIPMENT

5 Blade L. H. Cutting Unit, Model No. 03752  
(2 per machine)

5 Blade R. H. Cutting Unit, Model No. 03753  
(3 per machine)

7 Blade L. H. Cutting Unit, Model No. 03754  
(2 per machine)

7 Blade R. H. Cutting Unit, Model No. 03756  
(3 per machine)

11 Blade L. H. Cutting Unit, Model No. 03741  
(2 per machine)

11 Blade R. H. Cutting Unit, Model No. 03751  
(3 per machine)

L. H. Dethatcher Kit, Model No. 03730  
(2 per machine)

R. H. Dethatcher Kit, Model No. 03732  
(3 per machine)

Cutting Unit Fixed Head Kit, Model 03762  
(1 per machine)

Cutting Unit Floatation Kit, Model No. 03760  
(1 per machine)

Front Roller Kit, Model No. 03742  
(1 per machine)

Wiehle Roller Kit, Model No. 03740  
(1 per machine)

Rear Roller Scraper Kit, Part No. 59–6090  
(1 per cutting unit)

Front Roller Scraper Kit, Part No. 62–6220  
(1 per cutting unit)

Side Skid Kit, Model No. 03744  
(1 per machine)

Spark Arrester Muffler Kit, Part No. 74–2900  
(2 wheel drive only)

Spark Arrester Muffler Kit, Part No. 92–6074  
(4 wheel drive only)

R.O.P.S. Kit, Part No. 92–9286  
(Standard on 4 wheel drive machines)

# BEFORE OPERATING



## CAUTION

Before servicing or making adjustments to the machine, stop engine and remove key from the switch.

## CHECK ENGINE OIL

Check oil level of at the beginning of each day.

Crankcase capacity is 8 qt. (7.6 L) with filter.

1. Park machine on a level surface. Release engine cover latches (Fig. 1).

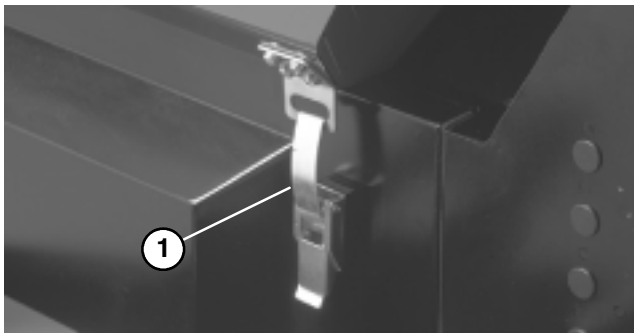

**Figure 1**  
1. Engine Cover Latch

2. Open engine cover.
3. Remove dipstick, wipe clean and reinstall dipstick into tube and pull it out again: Oil level should be up to FULL mark (Fig. 2).

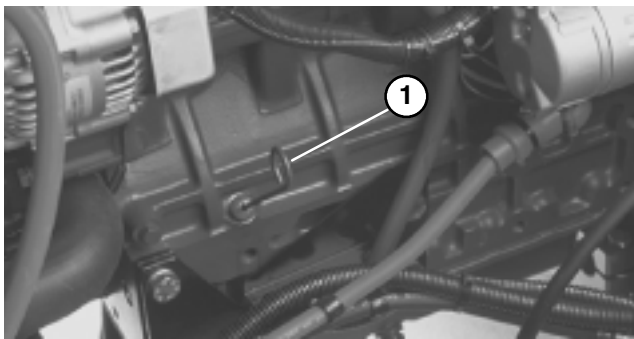
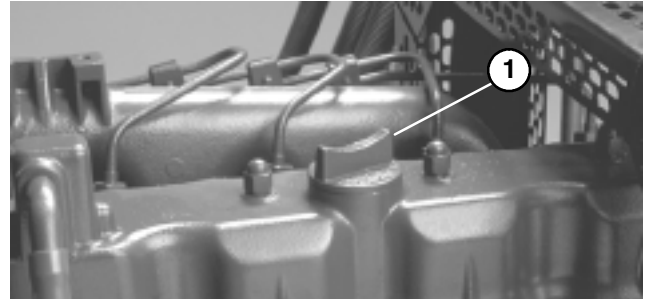

**Figure 2**  
1. Dipstick

4. If oil is below FULL mark, remove fill cap (Fig. 3) and add oil until level reaches FULL mark. DO NOT OVERFILL.
5. The engine uses any high-quality detergent oil having the American Petroleum Institute — API — "service classification" CD, CE, CF, CF-4 or CG-4. Use the following chart to select the proper viscosity grade for the temperature expected.

above 77°F (25° C)	SAE 30 or	SAE 10W-30 SAE 10W-40
32° to 77°F (0 to 25° C)	SAE 20 or	SAE 10W-30 SAE 10W-40
below 32°F (0° C)	SAE 10W or	SAE 10W-30 SAE 10W-40

**NOTE:** When using different oil, drain all old oil from crankcase before adding new oil.



**Figure 3**  
1. Oil Fill Cap

6. Install oil fill cap and dipstick.
7. Close engine cover and secure with the latches.

## CHECK COOLING SYSTEM

Check level of coolant at the beginning of each day. Capacity of system is 3.7 gal. (14 L).

1. Carefully remove radiator cap (Fig. 5) and expansion tank cap (Fig. 4).



## CAUTION

If engine is hot, pressurized coolant can escape and cause burns when the radiator cap is removed. Remove radiator cap slowly and carefully if engine coolant is hot.

2. Check level of coolant in radiator. Radiator should be filled to the top of the filler neck and the expansion tank filled to the marks on its side

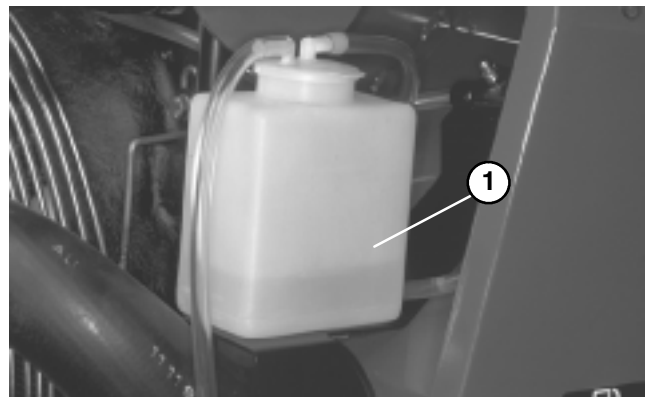

**Figure 4**  
1. Expansion tank

# BEFORE OPERATING

3. If coolant is low, add a 50/50 mixture of water and ethylene glycol anti-freeze. **DO NOT USE WATER ONLY OR ALCOHOL / METHANOL BASE COOLANTS.**
4. Install radiator cap and expansion tank cap.

## FILL FUEL TANK

1. Remove fuel tank cap (Fig. 5).
2. Fill tank to about one inch (25 mm) below bottom of filler neck with No. 2 diesel fuel. Then install cap.

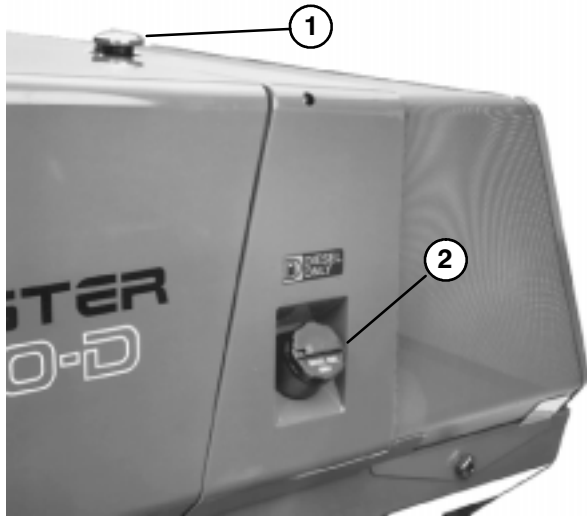

**Figure 5**  
1. Radiator Cap  
2. Fuel Tank Cap



## DANGER

Because diesel fuel is flammable, use caution when storing or handling it. Do not smoke while filling the fuel tank. Do not fill fuel tank while engine is running, hot, or when machine is in an enclosed area. Always fill fuel tank outside and wipe up any spilled diesel fuel before starting the engine. Store fuel in a clean, safety-approved container and keep cap in place. Use diesel fuel for the engine only; not for any other purpose.

## CHECK HYDRAULIC SYSTEM

1. Park machine on a level surface.
2. Look into sight glass (Fig. 6). Oil level should be even with arrows when checking warm oil. Oil will be 1/4 to 1/2 inch below arrows when cold.

3. If oil level is low, add hydraulic oil to the reservoir. Refer to Hydraulic Oil Specifications.

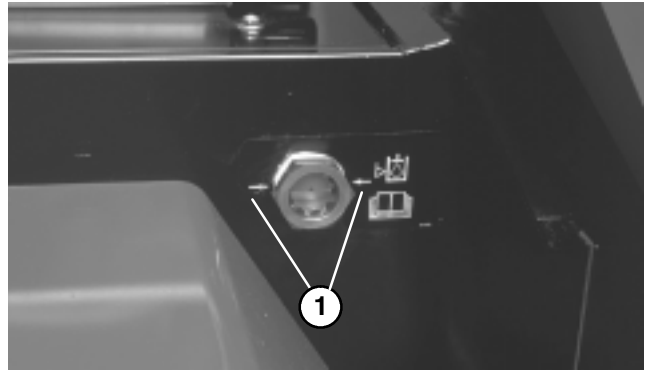

**Figure 6**  
1. Sight Glass Arrows

## CHECK REEL TO BEDKNIFE CONTACT

Each day before operating, check reel to bedknife contact, regardless if quality of cut had previously been acceptable. There must be light contact across the full length of the reel and bedknife (refer to Adjusting Cutting Units in Cutting Unit Manual, Step #1 – Reel to Bedknife Adjustment).

## CHECK TIRE PRESSURE

For normal mowing conditions and a wide variety of turf grasses, use these tire pressures: 13 psi front and 15 psi rear. However, when turf is either wetter or drier than normal, tire pressure may need to be changed. On hard turf, use high tire pressure (18 psi front and rear). When turf is soft, use low pressure (9 psi front and 12 psi rear).

**IMPORTANT:** Maintain even pressure in two front tires (ie. 13 psi) and both rear tires (ie 15 psi) to assure excellent quality-of-cut. Do not exceed 10 mph transport speed (for extended periods) when tire pressure is 12 psi or less because tires may be damaged. Maximum transport speed can be used when front tire pressure is 13 psi or more.

## REAR BALLAST

This unit complies with the ANSI B71.4-1990 Standard when rear tires are filled with calcium chloride and 2 rear wheel weight kits (Part No. 11-0440) are installed.

**IMPORTANT:** If a puncture occurs in a tire with calcium chloride, remove unit from turf area as quickly as possible. To prevent possible damage to turf, immediately soak affected area with water.

# KNOW YOUR CONTROLS

**Seat Adjusting Lever** (Fig. 7) – Seat adjusting lever allows 5.9 inch (15 cm) fore and aft adjustment in 19/32 inch (15 mm) increments.

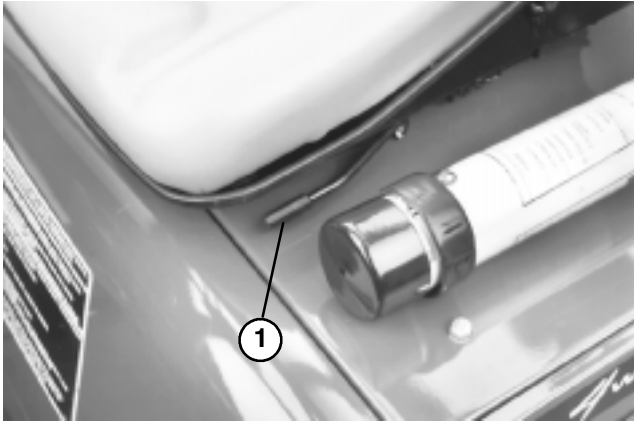

**Figure 7**  
1. Seat Adjusting Lever

**Arm Rest** (Fig. 8) – Pivot arm rest up and down for operator comfort.

**Backrest Knob** (Fig. 8) – Backrest knob adjusts backrest angle from 5–20 degrees.

**Suspension Lever** (Fig. 8) – Suspension lever adjusts seat to the operator's weight. Use up position for light weight operators, center position for medium weight operators and down for heavier weight operators.

**Note:** Backrest and bottom seat cushions are removable.

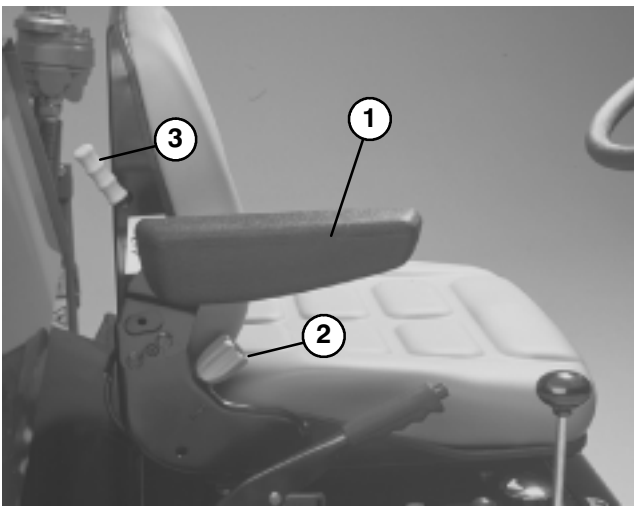

**Figure 8**  
1. Arm Rest  
2. Backrest Knob  
3. Suspension Lever



## CAUTION

**TO ASSURE INTERLOCK SWITCH OPERATES PROPERLY, SEAT SUSPENSION MUST BE SET FOR THE WEIGHT OF EACH OPERATOR. IF SUSPENSION IS NOT SET CORRECTLY, THE ENGINE WILL RUN INTERMITTENTLY AND TEND TO STALL. TO CORRECT THIS, SET SUSPENSION LIGHTER.**

**Warning Light Test Button** (Fig. 9) – Before operating, press test button. All lights on the steering tower should illuminate. Any light that does not come on indicates an electrical malfunction that should be repaired immediately. Oil pressure and electrical no charge indicator lights illuminate when turning key switch "ON".

**Hydraulic and Engine Indicator Lights** (Fig. 9) – If these lights come on, stop machine and make repairs immediately.

**Engine Oil Pressure Warning** (Fig. 9) – Dangerously low engine oil pressure is indicated by both a warning indicator light and audible signal. When this occurs, stop the engine immediately and correct problem.

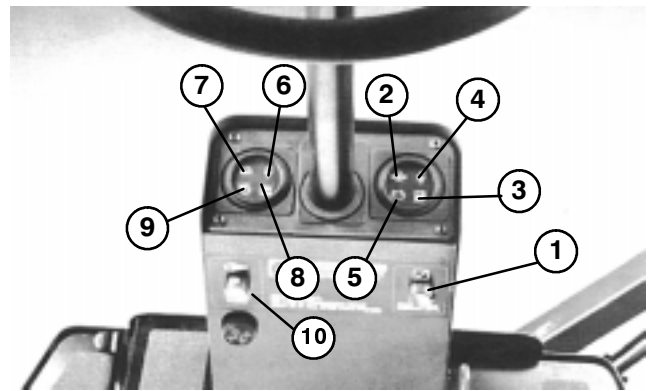

**Figure 9**

1. Warning Light Check Switch
2. Engine Oil Pressure Warning
3. Fuel System Warning
4. Coolant Temperature Warning
5. Electrical No Charge Warning
6. Hydraulic Oil Temperature Warning
7. Hydraulic Oil Level Warning
8. Hydraulic Oil Filter Warning
9. Air Cleaner Warning
10. Alarm Silence Button

**Fuel System Warning** (Fig. 9) – A warning indicator light and audible signal warn of excess water in fuel system. Remove water from system.

**Coolant Temperature Warning** (Fig. 9) – If engine coolant temperature exceeds 221° F (105° C) a warning indicator light illuminates and audible signal sounds. The engine shuts down if temperature of coolant exceeds 230° F (110° C). Switch resets automatically when system and engine cools down.

# KNOW YOUR CONTROLS

**Electrical No Charge Warning** (Fig. 9) – No charge to the batteries is indicated by a warning indicator light and audible signal.

**Hydraulic Oil Temperature Warning** (Fig. 9) – A warning indicator light and audible signal warn of excessively high hydraulic temperature.

**Hydraulic Oil Level Warning** (Fig. 9) – A warning indicator light and audible signal warn of low hydraulic oil level. If oil level drops further, the engine will automatically be stopped. Engine cannot be restarted until oil supply is brought to a safe level.

**Hydraulic Oil Filter Warning** (Fig. 9) – A warning indicator light and audible signal warn of clogged hydraulic filter.

**Air Cleaner Warning** (Fig. 9) – A warning indicator light and audible signal warn the filter is clogged and in need of service.

**Alarm Silence Button** (Fig. 9) – Pressing button silences alarm. Alarm system will disengage and automatically reset when problem is corrected or the alarm silence button is pressed.

**Traction Pedal** (Fig. 10) – Controls forward and reverse operation. Depress top of pedal to move forward and bottom to move backward. Ground speed depends on how far pedal is depressed. For maximum ground speed, fully depress pedal while throttle is in FAST. For maximum power under load or when going uphill, keep engine rpm high by having throttle in FAST and traction pedal held stationary against ground speed limiter. If engine rpm begins to decrease due to load, gradually reduce traction pedal pressure until engine speed is increased.

To stop, reduce foot pressure on traction pedal and allow it to return to center position. On extreme downhill slopes, apply pressure to REVERSE side of pedal, or operate with heel on REVERSE and toe on FORWARD portion of pedal.

**Ground Speed Limiter** (Fig. 10) – Controls traction pedal movement. Limiter lever helps control the rate of clip and eliminates sudden speed variations over rough terrain.

**IMPORTANT: Cam lever nut (Fig. 10 Inset) can be tightened if limiter stop will not hold traction pedal in desired position.**

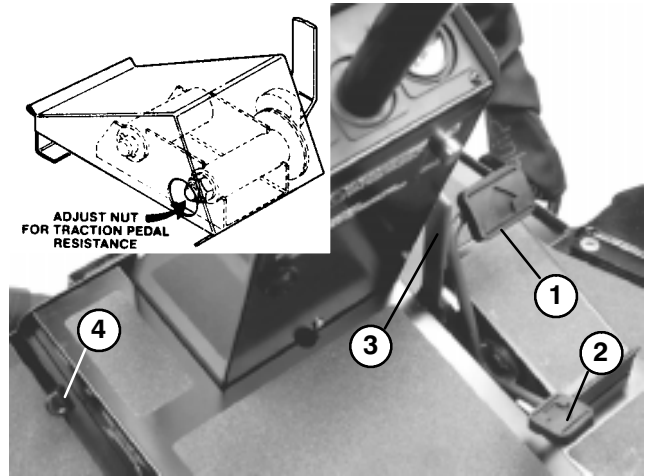

**Figure 10**

1. Top of Traction Pedal – Forward
2. Bottom of Traction Pedal – Reverse
3. Speed Limiter
4. Transport Latch – Front Cutting Units

**Transport Latches** (Fig. 10 and 11) – Latches secure cutting units in upright position for transport operation. Latch for front cutting units is foot-operated (Fig. 9). Hand-operated latches control the center and outside cutting units (Fig. 11).

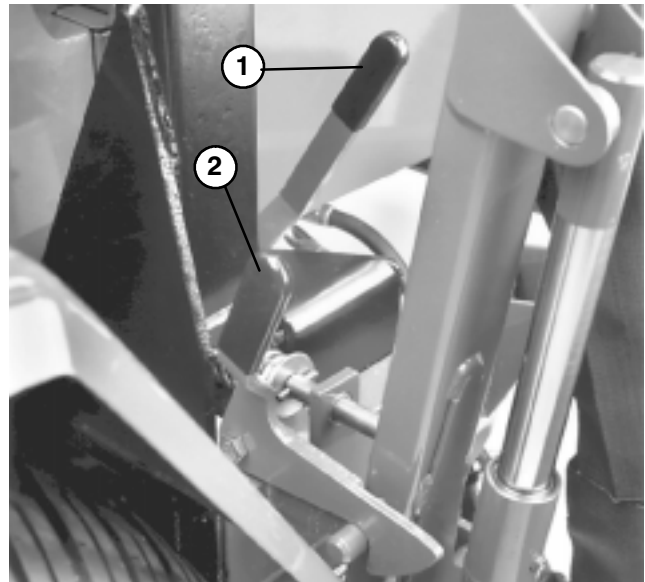

**Figure 11**

1. Center Cutting Unit Latch
2. Outside Cutting Unit Latch

# KNOW YOUR CONTROLS

**Cutting Unit Lift Controls** (Fig. 12) – The two outside levers raise and lower the two outside cutting units. The center lever raises and lowers the two front and the center cutting units. Engine must be running to lower cutting units. When cutting units are lifted, reels automatically stop. Do not allow levers to snap-back

to neutral, or cutting units may not float freely.

**Engine Override Button** (Fig. 12) – When button is depressed, engine can be operated after it has over heated and automatically been stopped by the electrical safety system. Use only for short intervals.

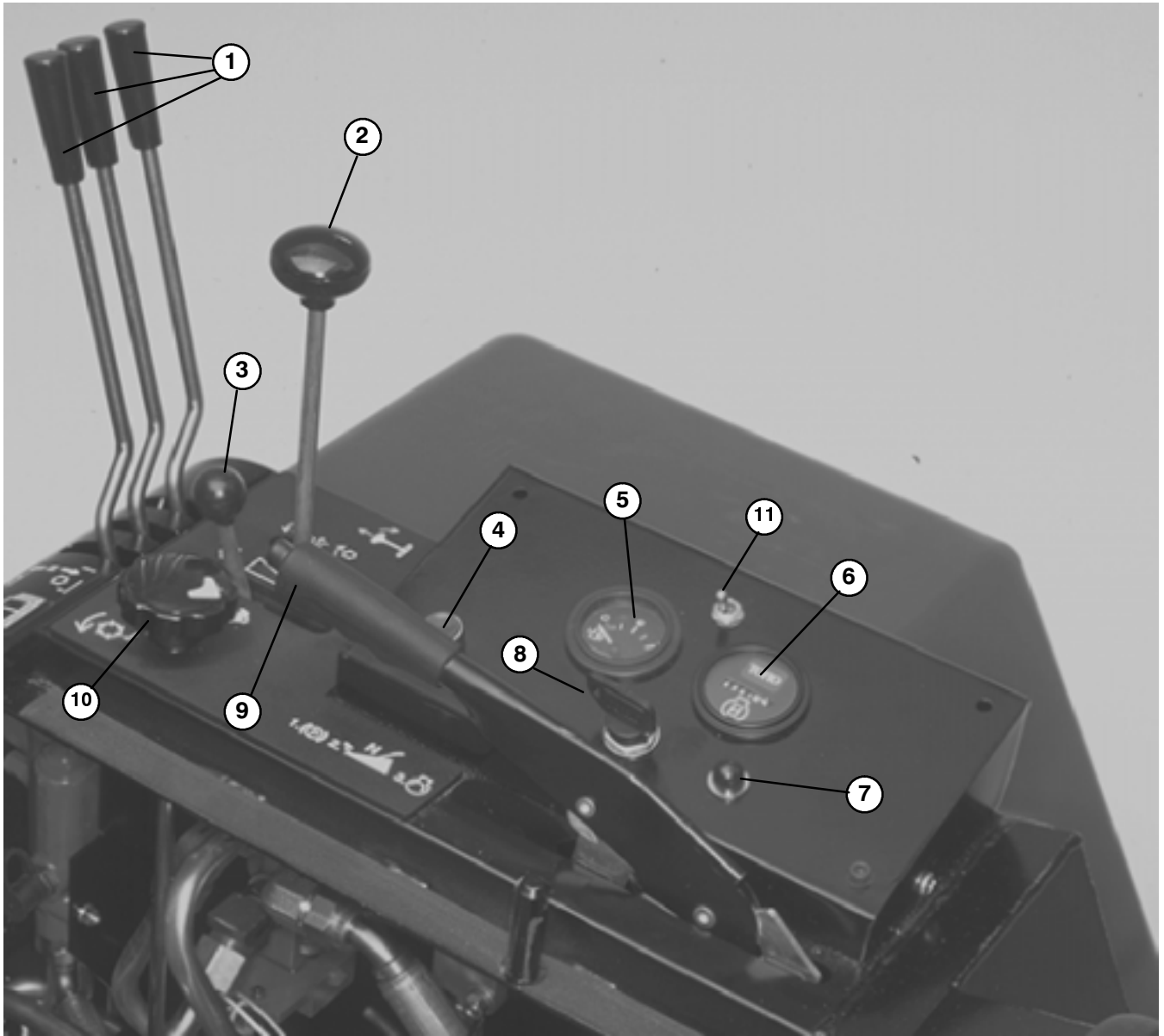

**Figure 12**

- |                               |  |
|-------------------------------|--|
| 1. Cutting Unit Lift Controls | 7. Engine Preheat Indicator Light                |
| 2. Mow/Backlap Lever          | 8. Key Switch                                    |
| 3. Throttle                   | 9. Hand Brake                                    |
| 4. Engine Override Button     | 10. Reel Speed Control                           |
| 5. Fuel Gauge                 | 11. 4 Wheel Drive Switch<br>(4 Wheel Drive Only) |
| 6. Hourmeter                  |  |

# KNOW YOUR CONTROLS

**Fuel Level Gauge** (Fig. 12) – Indicates amount of fuel in tank.

**Hour Meter** (Fig. 12) – Indicates total hours that machine has been operated.

**Note:** Lines circling in the small window at left side of gauge indicate hour meter is operating.

**Engine Preheat Indicator Light** (Fig. 12) – Light turns on when key is moved to ON position. Glow plugs engage for 10 seconds, then, light goes off when engine is ready to start.

**Key Switch** (Fig. 12) – Three positions: OFF, ON and START. Rotate key to START and release key when engine begins running. To stop engine, rotate key to OFF.

**Parking Brake Lever** (Fig. 12) – Pull lever up to lock brake. To release brake, pull up on lever, press button and lower lever. Brake must be engaged to start engine. Always engage parking brake before getting off seat.

**Mow–Backlap Lever** (Fig. 12) – Move lever forward to engage cutting units. Move lever to the center to stop the cutting units. To backlap cutting units, lift lever over stop and hold in the rear position.

**CAUTION: Do not move lever directly between MOW and BACKLAP positions. Pause briefly in STOP position.**

**Reel Speed Control** (Fig. 12) – Rotate knob clockwise to increase reel speed, counter–clockwise to decrease speed. Use in conjunction with the ground speed limiter to achieve appropriate rate of clip.

**Throttle Control** (Fig. 12) – Move control forward to increase engine speed, backward to decrease speed.

**4 Wheel Drive Switch** (Fig. 12) – (4 wheel drive model only) Move switch forward to engage 4 wheel drive. Move switch to rear position to disengage 4 wheel drive.

## OPERATING INSTRUCTIONS

	<b>CAUTION</b>
<b>Before servicing or making adjustments to the machine, stop engine and remove key from the switch.</b>	

### STARTING AND STOPPING

1. Sit on the seat, keep foot off traction pedal. Assure parking brake is engaged (Fig. 12). Traction pedal and mow/backlap lever must be in neutral.
2. Turn key switch to ON position. When glow plug indicator light goes off, engine is ready to START.
3. Turn key to START. Release key when engine starts.
4. To stop, disengage and move all controls to neutral and set parking brake. Raise and latch all cutting units in transport position. Turn key to OFF and remove it from switch.

### PRIMING FUEL SYSTEM

**IMPORTANT: The fuel system must be primed when a new engine is started for the first time, if it runs out of fuel or if maintenance is performed on the fuel system.**

1. Raise engine cover.

**Note:** The fuel pump, located on left side of engine, behind fuel injection pump, can be manually primed to get fuel from fuel tank to fuel filters and water/separator (Fig. 13).

2. Insert a 3/16" hose over bleed screw and run other end into a container to catch fuel (Fig. 13).

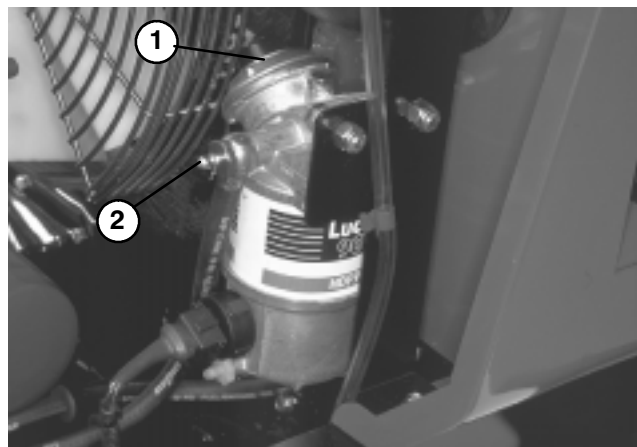

**Figure 13**  
1. Primer Plunger  
2. Bleed Screw

3. Loosen fuel filter / water separator bleed screw (Fig. 13) a few turns. Pump priming plunger until a steady stream of fuel comes out of hole in bleed screw. When fuel stops foaming, tighten the bleed screw during the downstroke of the priming plunger. Wipe up any spilled fuel.

**Note:** Priming fuel filter without opening bleed screw may damage priming plunger.



# OPERATING INSTRUCTIONS

4. Pump priming plunger until resistance is felt. Try to start engine. If engine does not start repeat step 3.

5. It may be necessary to bleed the air out of the fuel line between the fuel filter / water separator and the injection pump. To do this, loosen the knob on the injection pump (Fig. 14) and pump primer lever, located below injection pump.

6. If fuel does not flush during the priming process, check both fuel filters for restrictions and replace if required. Refer to Changing Fuel Filters, page 25.

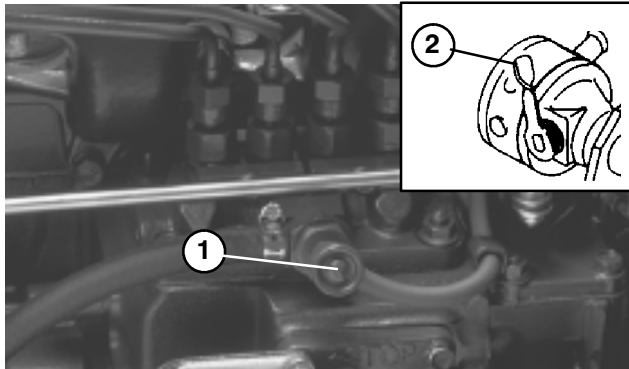

**Figure 14**

1. Injection Pump Bleed Screw
2. Fuel Pump Primer Lever

## CHECKING WARNING INDICATOR LIGHTS

Each day before operating, assure all warning lights are working.

**Note: Alarm will continue to sound until problem is corrected or until alarm silence button is pressed. If a second problem is encountered, the alarm will not sound but indicator light will illuminate.**

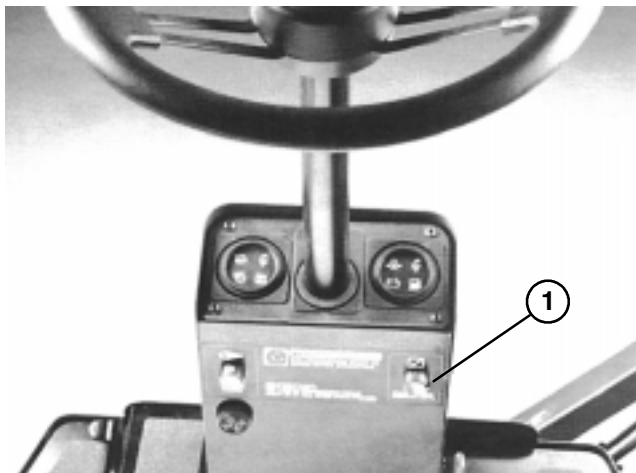

**Figure 15**

1. Warning Indicator Light Test Button

## CHECKING INTERLOCK SYSTEM.



### CAUTION

**THE INTERLOCK SWITCHES ARE FOR THE OPERATOR'S PROTECTION, SO DO NOT DISCONNECT THEM. CHECK OPERATION OF THE SWITCHES DAILY TO ASSURE INTERLOCK SYSTEM IS OPERATING. IF A SWITCH IS DEFECTIVE, REPLACE IT BEFORE OPERATING. REGARDLESS IF SWITCHES ARE OPERATING PROPERLY OR NOT, REPLACE THEM EVERY TWO YEARS TO ASSURE MAXIMUM SAFETY.**

1. In a wide open area free of debris and bystanders, lower cutting units to the ground. Stop engine.

2. Sit on the seat and engage parking brake (Fig. 12). Turn key and try to start engine with Mow-Backlap lever (Fig. 12) in both the MOW and BACKLAP positions. If engine cranks, there is a malfunction that must be repaired immediately. If engine does not crank, the cutting unit drive switch is operating properly.

3. Sit on the seat and disengage the parking brake. Turn key and try to start engine with Mow-Backlap lever in STOP. If engine cranks, there is a malfunction that must be repaired immediately. If engine does not crank, brake switch is operating properly.

4. Engage parking brake, start engine and lower cutting units. Move Mow-Backlap lever to MOW. Raise off the seat; engine should stop within a few seconds, which indicates the interlock system is operating. Also raise off the seat with lever in BACKLAP. Engine should stop, indicating interlock system is operating. If engine does not stop, there is a malfunction that must be repaired immediately.

**Note:** There is a 1 – 2 second delay between rising off seat and engine shut off.

5. Engage parking brake, move Mow-Backlap lever to NEUTRAL, start engine, disengage hand brake and raise off seat. If engine stops, interlock system is operating. If engine does not stop, there is a malfunction that must be repaired immediately.

## PUSHING OR TOWING TRACTION UNIT

In an emergency, the traction unit can be pushed or towed for a very short distance, by using the traction pump by-pass valve.

**IMPORTANT:** Do not push or tow the traction unit faster than 2 to 3 MPH ( 3 to 5 Km/Hr) because hydraulic system may be damaged. If traction unit must be moved a considerable distance, transport it on a truck or trailer.

# OPERATING INSTRUCTIONS

1. Remove retainer clip from seat lock rod (Fig. 16).

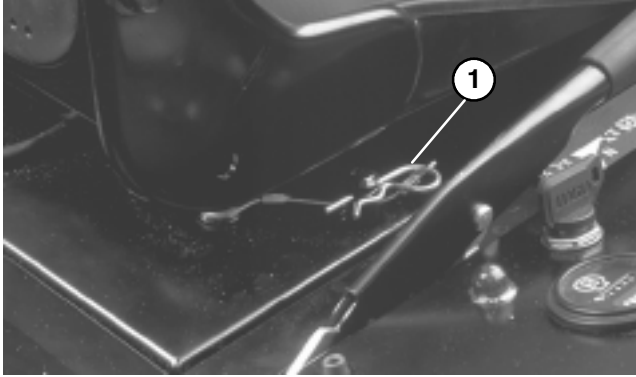

**Figure 16**

1. Retainer Clip

2. Raise seat and support it in upright position with seat support rod (Fig. 17).

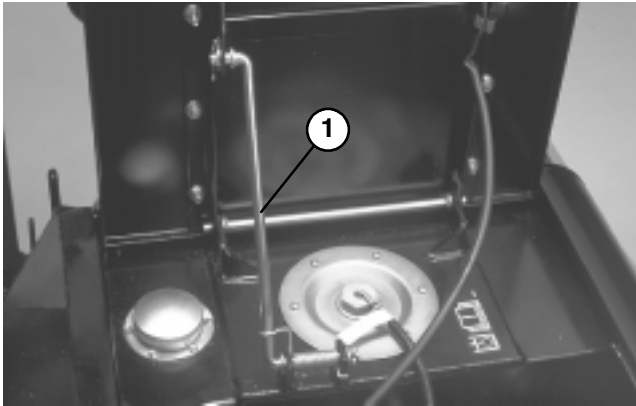

**Figure 17**

1. Seat Support Rod

4. Rotate by-pass valve 90 degrees (Fig. 18). Opening the valve opens an internal passage in the traction pump, thereby by-passing hydraulic oil. Because oil is by-passed, traction unit can be moved without damaging the hydraulic system.

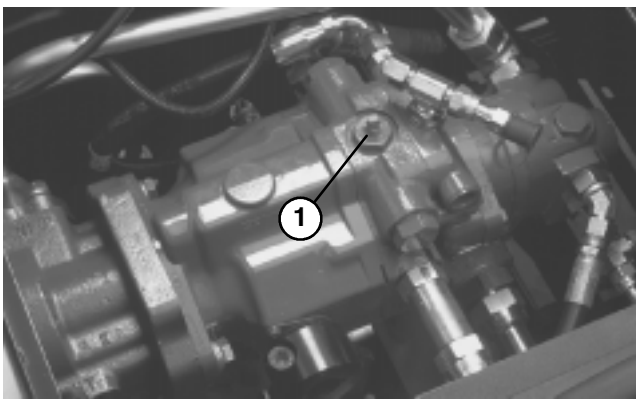

**Figure 18**

1. By-Pass Valve

**IMPORTANT:** Make sure that hand brake is engaged before opening the by-pass valve.

5. Before starting engine, close by-pass valve. Do not start engine when valve is open.

**IMPORTANT:** Running the machine with the by-pass valve open will cause the hydraulic system to overheat.



**DANGER**

Vehicle will roll with front wheel motors disengaged. Vehicle must be on level surface or wheels must be blocked. There is no effective braking with wheel motors disengaged.

If towing, with front wheel motors disengaged, Optional Tow Bar Assembly, Toro part no. 58-7020, must be used.

## OPERATING CHARACTERISTICS

**Familiarization** – Before mowing grass practice operating in an open area. Start and stop the engine. Operate in forward and reverse. Lower and raise cutting units simultaneously and individually. Engage and disengage reels. Operate with all cutting units down, then with only an individual cutting unit. When you feel familiar with the machine, practice operating around trees and obstacles. Also drive up and down slopes using both mowing and transport speeds.

**WARNING:** When operating 4 wheel drive machine, always use the seat belt and ROPS together.

**Warning System** – If a warning light comes on during operation, stop the machine immediately and correct the problem before continuing operation. Serious damage could occur if the machine is operated with a malfunction. For short intervals, however, the emergency engine override button (Fig. 12) can be used to operate the engine if it stops because of overheating.

**Mowing** – When you are at the area to be mowed, release front, center and outside cutting unit transport latches, lower cutting units, engage hand brake and stop the engine.

**Cutting Unit Grass Deflectors** – Adjust grass deflectors to horizontal position (Fig. 19), so clippings disperse backward; out and away from the cutting units. This will prevent clumps of clippings, especially wet clippings, dropping off the machine or cutting units, which affects the visual appearance of the turf.

**Note:** Generally you can adjust the deflectors down slightly in dry grass and up slightly in wet grass.

# OPERATING INSTRUCTIONS

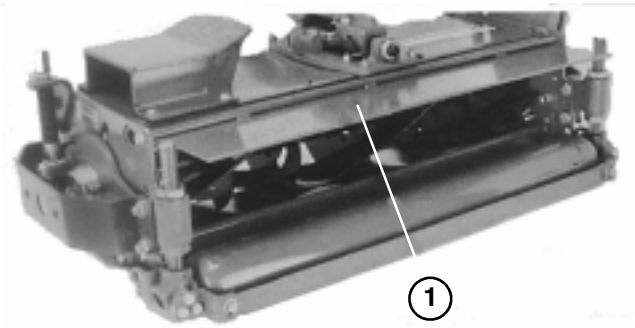

**Figure 19**  
1. Grass Deflector

While checking speedometer, match ground speed limiter (Fig. 20) and reel speed control knob (Fig. 21) to desired height-of-cut: refer to Cutting Chart (Fig. 22). Use decal at side of steering column as a guide only.

Start engine and move throttle to FAST so engine is running at maximum speed. Disengage hand brake. To move forward, press traction pedal forward (Fig. 20). Move Mow-Backlap lever to MOW. Reels are now spinning. Maintain traction pedal contact with ground speed limiter (Fig. 20) to assure consistent clip and quality-of-cut.

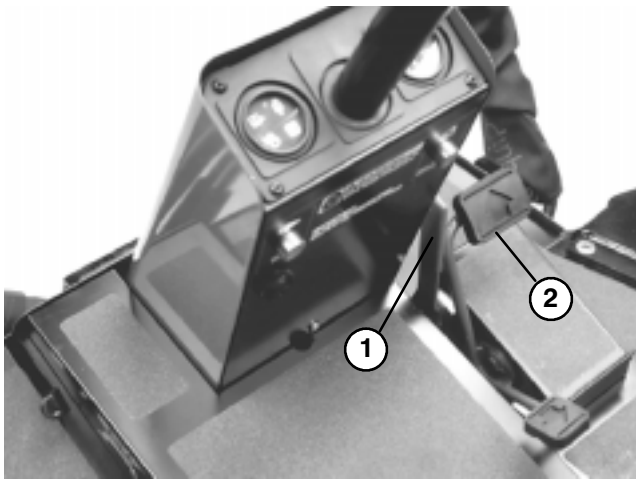

**Figure 20**  
1. Ground Speed Limiter  
2. Traction Pedal

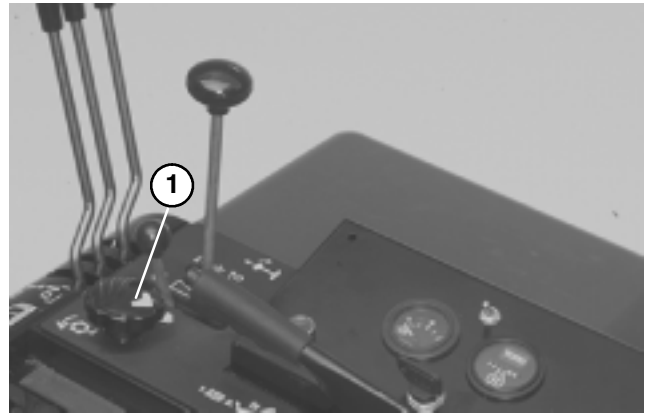

**Figure 21**  
1. Reel Speed Control

**CAUTION:** This product may exceed noise levels of 85 dB(A) at the operator position. Ear protectors are recommended for prolonged exposure to reduce the potential of permanent hearing damage.

**Transport** – When mowing is complete, move MOW-BACKLAP lever to STOP. Raise cutting units by pulling back on lift control levers. Hold levers back until cutting units are fully raised (a squeal from the hydraulic system means cutting units are fully raised). Lock cutting units in place with transport latches. Be careful when driving between objects so you do not accidentally damage the machine or cutting units.

**Matching Ground Speed and Reel Speed** – Vary reel speed (while maintaining constant ground speed) to establish the best quality of cut for the area being mowed. Reel speeds either too fast or too slow for conditions may effect the quality of cut. Use the following cutting chart (Fig. 22) and decal on steering console as a guide for initial adjustment of ground and reel speeds.

# OPERATING INSTRUCTIONS

## CUTTING CHARTS

Relate HOC and ground speed to required reel speed setting on a 1 thru 5 scale on reel speed knob.  
 Note: 1 = 800 RPM; 2 = 900 RPM; 3 = 1000 RPM; 4 = 1100 RPM and 5 = 1200 RPM (Fig. 26).

\* Speeds are approximate

### Recommended Reel Speed Settings

#### 5 Blade Reel

HOC	Ground Speed In MPH				
	3	4	5	6	7
1	1	3	5	N/R	N/R
1.25	N/R	1	3	5	N/R
1.5	N/R	N/R	2	3	4
2	N/R	N/R	N/R	1	2
2.5	N/R	N/R	N/R	N/R	1

#### 7 Blade Reel

HOC	Ground Speed In MPH				
	3	4	5	6	7
1/2	2	5	N/R	N/R	N/R
5/8	1	3	5	N/R	N/R
3/4	N/R	1	3	5	N/R
1	N/R	N/R	1	2	3
1.25	N/R	N/R	N/R	1	2

#### 11 Blade Reel

HOC	Ground Speed In MPH				
	3	4	5	6	7
3/8	1	3	5	N/R	N/R
1/2	N/R	1	3	4	N/R
5/8	N/R	N/R	1	2	4
3/4	N/R	N/R	N/R	1	2

Note: N/R = Not Recommended

Note: Positions 4 and 5 are only attainable with a special coupler (Part No. 58-1530). Contact your Toro Dealer for information.

Figure 22

# LUBRICATION



## CAUTION

Before servicing or making adjustments to the machine, stop engine and remove key from the switch.

### GREASING BEARINGS AND BUSHINGS

The machine has grease fittings that must be lubricated after every 50 hours of operation with No. 2 General Purpose Lithium Base Grease. Lubricate fitting immediately after every washing regardless of interval listed. The lubrication points are: lift arms (5) (Fig. 23), rear axle (6) (Fig. 24), floating or fixed head kit pivots (Fig. 25) and cutting unit reel and roller bearings (Fig. 26). Also, grease fitting on reel control valve (not shown), located under right hand console.

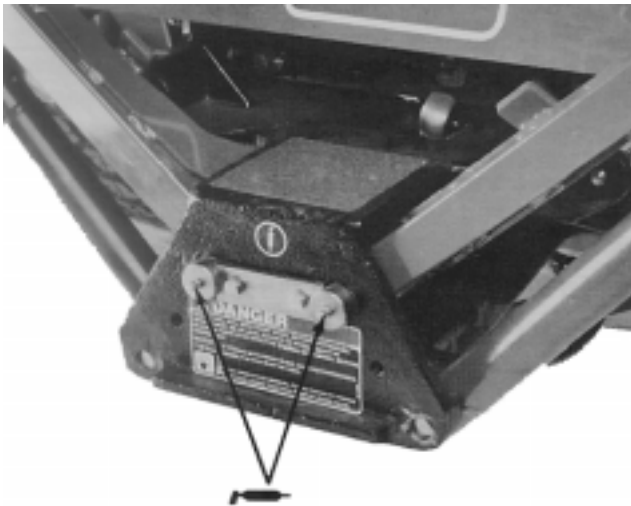

**Figure 23**

Lift Arms (5 fittings)

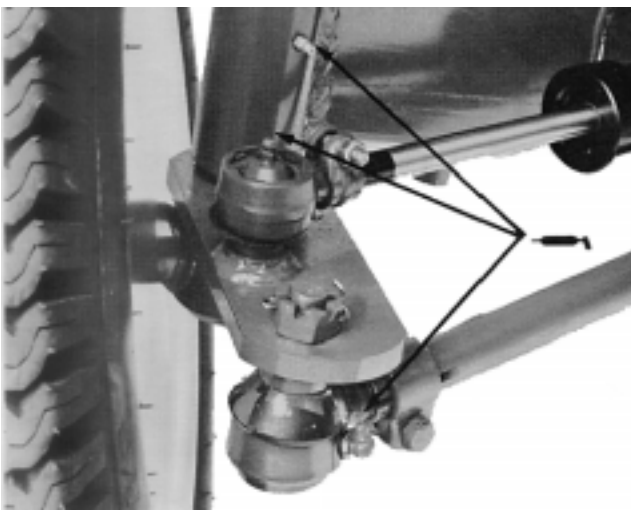

**Figure 24**

Rear Axle (6 fittings)

**NOTE:** Remove the plastic caps over the fittings on the floating or fixed head kit pivots and replace after greasing (Fig. 25).

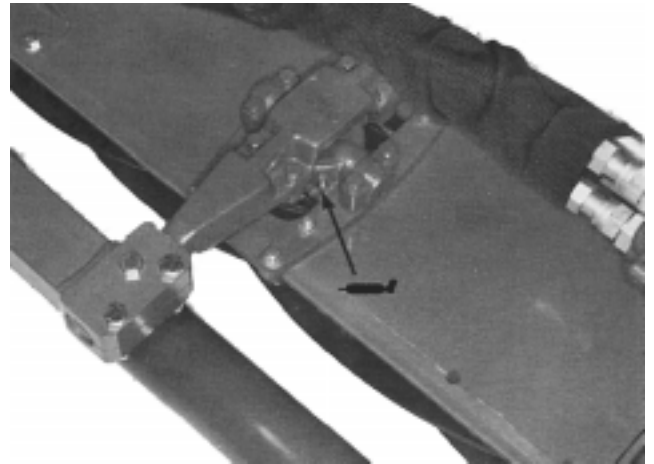

**Figure 25**

Floating or Fixed Head Kit Pivots  
(Floating Head Kit Shown)

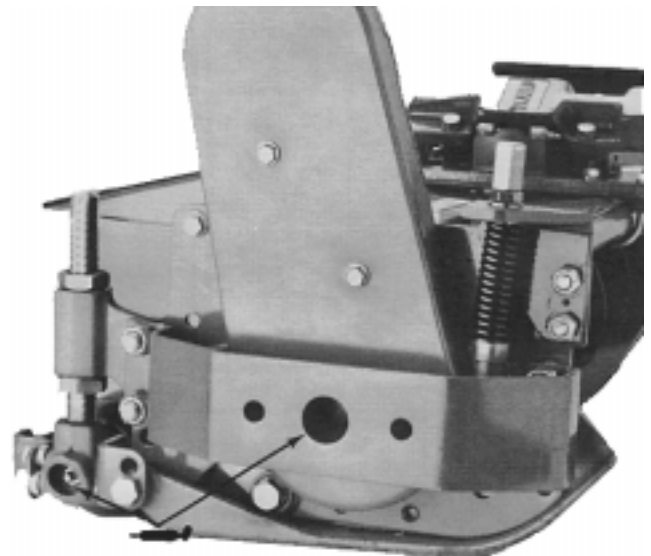

**Figure 26**

Reel & Roller Bearings

1. Wipe grease fitting clean so foreign matter cannot be forced into the bearing or bushing.
2. Pump grease into the bearing or bushing.
3. Wipe up excess grease.

# MAINTENANCE CHART AND CHECKLIST

Daily Maintenance: (duplicate this page for routine use)

Check proper section of Operator's Manual for fluid specifications

Maintenance Check Item	Daily Maintenance Check For Week Of _____						
	MON	TUES	WED	THURS	FRI	SAT	SUN
✓ Safety Interlock Operation							
✓ Parking Brake Operation							
✓ Engine Oil Level							
✓ Fuel Level							
✓ Cooling System Fluid Level							
Drain Water/Fuel Separator							
✓ Air Filter Restriction Indicator							
✓ Radiator, Oil Cooler and Screen for Debris <sup>1</sup>							
Clean Traction Pedal Lockout							
✓ Unusual Engine Noises <sup>2</sup>							
✓ Unusual Operating Noises							
✓ Hydraulic System Oil Level							
✓ Hydraulic Hoses for Damage							
✓ Fluid Leaks							
✓ Tire Pressure							
✓ Instrument Operation							
✓ Warning Lamps Operation							
✓ Reel-to-Bedknife Adjustment							
✓ Height-of-Cut Adjustment							
Lubricate All Grease Fittings <sup>3</sup>							
Touch-up Damaged Paint							

<sup>1</sup>= Use only low pressure compressed air for debris removal. **Do not use water.**

<sup>2</sup>= Check glow plugs and injector nozzles, if hard starting excess smoke or rough running is noted.

<sup>3</sup>= Immediately after every washing, regardless of the interval listed.

**Notation for areas of concern:**      Inspection performed by \_\_\_\_\_

Item	Date	Information
1		
2		
3		
4		
5		
6		
7		
8		

# MAINTENANCE



## CAUTION

Before servicing or making adjustments to the machine, stop engine and remove key from the switch.

## GENERAL AIR CLEANER MAINTENANCE

1. Check air cleaner body for damage which could possibly cause an air leak. Replace a damaged air cleaner body.
2. Service the air cleaner filters when ever air cleaner indicator light illuminates and warning signal sounds or every 400 hours (more frequently in extreme dusty or dirty conditions). Do not over service air filter.
2. Be sure cover is sealing around air cleaner body.

## SERVICING AIR CLEANER

1. Remove knobs securing rear screen to frame (Fig. 27). Remove screen.

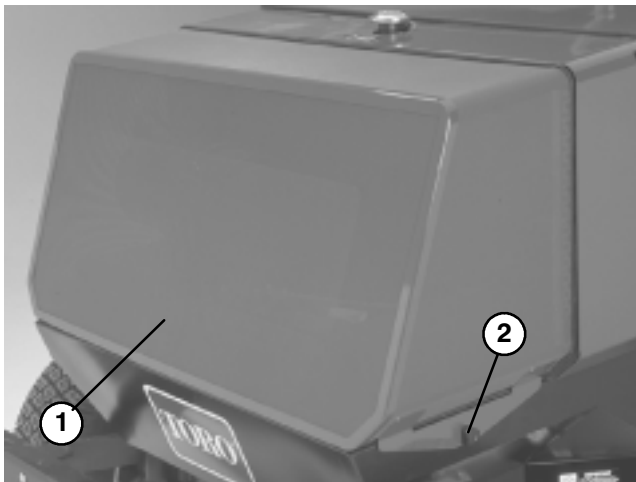

**Figure 27**  
1. Rear Screen  
2. Knob

2. Release latches securing air cleaner cover to air cleaner body. Separate cover from body. Clean inside of air cleaner cover.

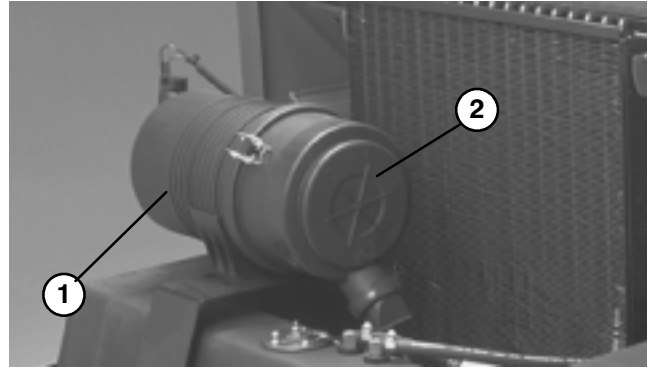

**Figure 28**

1. Air Cleaner Body
2. Air Cleaner Cover

3. Gently slide primary filter out of air cleaner body to reduce the amount of dust dislodged. Avoid knocking filter against air cleaner body. **Do not remove safety filter.**
4. Inspect primary filter and discard if damaged. Do not wash or reuse a damaged filter.

**IMPORTANT: Never attempt to clean a safety filter (Located inside primary filter). Replace the safety filter with a new one after every three primary filter services.**

### Washing Method

- A. Prepare a solution of filter cleaner and water and soak filter element about 15 minutes. Refer to directions on filter cleaner carton for complete information.
- B. After soaking filter for 15 minutes, rinse it with clear water. Maximum water pressure must not exceed 40 psi to prevent damage to the filter element. Rinse filter from clean side to dirty to side.
- C. Dry filter element using warm, flowing air (160°F max), or allow element to air-dry. Do not use a light bulb to dry the filter element because damage could result.

### Compressed Air Method

- A. Blow compressed air from inside to the outside of dry filter element. Do not exceed 100 psi to prevent damage to the element.
  - B. Keep air hose nozzle at least 2" from filter and move nozzle up and down while rotating the filter element. Inspect for holes and tears by looking through the filter toward a bright light.
5. Inspect new filter for shipping damage. Check sealing end of filter. Do not install a damaged filter.
  6. Insert new filter properly into air cleaner body. Make sure filter is sealed properly by applying pressure to outer rim of filter when installing. Do not press on flexible center of filter.
  7. Reinstall cover and secure latches. Make sure cover is positioned with TOP side up.

# MAINTENANCE

## ENGINE OIL AND FILTER

Change oil and filter after the first 50 hours of operation and every 100 hours thereafter.

1. Remove drain plug (Fig. 29) and let oil flow into drain pan. When oil stops, install drain plug.

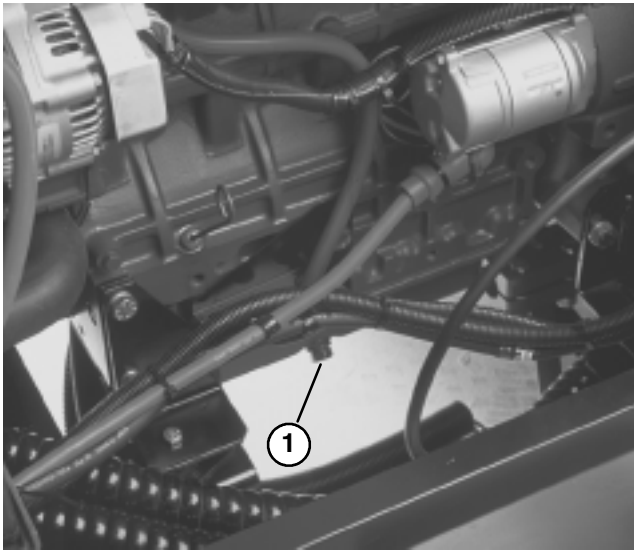

**Figure 29**  
1. Drain Plug

2. Remove oil filter (Fig. 30). Apply a light coat of clean oil to the new filter seal before screwing it on. **DO NOT OVER-TIGHTEN.**
3. Add oil to crankcase. Refer to Check Engine Oil, page 11 for oil specifications.

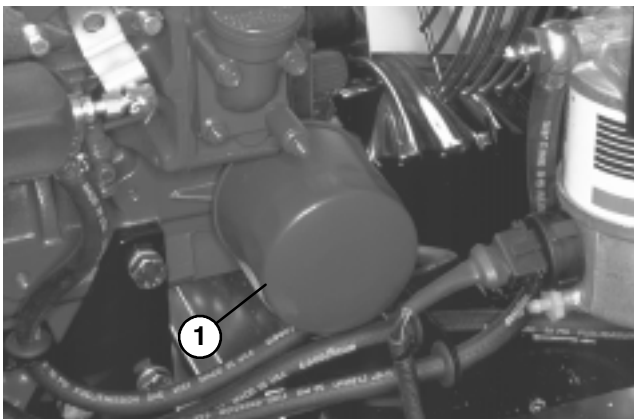

**Figure 30**  
1. Oil Filter

## FUEL SYSTEM

### Fuel Tank

Drain and clean fuel tank every 800 hours of operation or yearly, whichever comes first. Also, drain and clean tank if fuel system becomes contaminated or if machine is to be stored for an extended period. Use clean fuel to flush out the tank.



## DANGER

Because diesel fuel is highly flammable, use caution when storing or handling it. Do not smoke while filling the fuel tank. Do not fill fuel tank while engine is running, hot, or when machine is in an enclosed area. Always fill fuel tank outside and wipe up any spilled diesel fuel before starting the engine. Store fuel in a clean, safety-approved container and keep cap in place. Use diesel fuel for the engine only; not for any other purpose.

### Fuel Lines and Connections

Check lines and connections every 400 hours or yearly, whichever comes first. Inspect for deterioration, damage, or loose connections.

### Draining Fuel Filter / Water Separator

Drain water or other contaminants from fuel filter / water separator daily.

1. Place a clean container under fuel filter (Fig. 31).

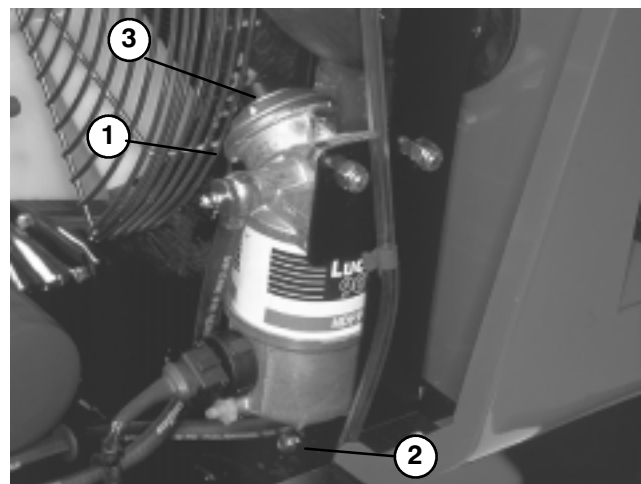

**Figure 31**  
1. Fuel Filter / Water Separator  
2. Drain Screw  
3. Primer Plunger

2. Loosen drain thumb screw on side of fuel filter and press primer plunger until only fuel is evident draining into container.
3. Tighten drain screw.



# MAINTENANCE

## Changing Fuel Filter

Replace fuel filter if fuel flow becomes restricted, after every 400 hours of operation or annually, whichever comes first.

1. Unscrew bottom filter cap from filter assembly. Remove cap, gaskets, o-ring and filter from assembly. Note position of gaskets and o-ring when disassembling from filter.
2. Install new filter, gaskets, o-ring with filter assembly cap.
3. Prime fuel system, refer to Priming Fuel System.

## Changing Inline Fuel Filter

Replace fuel filter if fuel flow becomes restricted, after every 400 hours of operation or annually, whichever comes first.

1. Clamp both fuel lines that connect to fuel filter (Fig. 33) so fuel cannot drain when lines are removed.
2. Loosen hose clamps at each end of filter, pull fuel lines off and discard filter.
3. Be sure arrow on side of filter points away from tank. Slide hose clamps onto ends of fuel lines and push fuel lines onto fuel filter. Tighten clamps.

## ENGINE COOLING SYSTEM

1. Removing Debris – Remove debris from oil cooler, radiator and rear screen daily, clean more frequently in dirty conditions.

A. Turn engine off, release front engine cover latches and raise engine cover. Clean engine area thoroughly of all debris.

B. Remove knobs securing rear screen to frame and remove screen (Fig. 32).

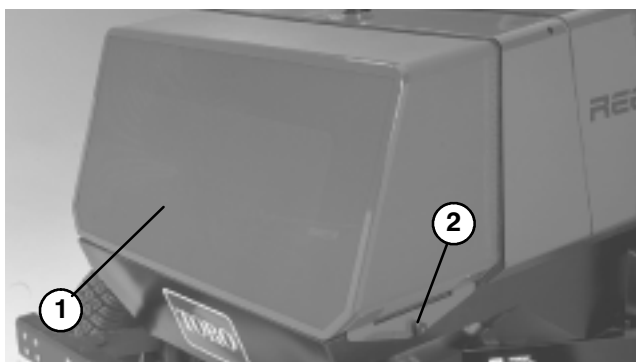

**Figure 32**

1. Rear Screen
2. Knob

C. Lift up on oil cooler handles and pivot rearward in mounting slot. Clean both sides of oil cooler, radiator and rear engine area thoroughly with compressed air.

D. Pivot oil cooler back into position and install rear screen.

- E. Lower engine cover and secure latches.

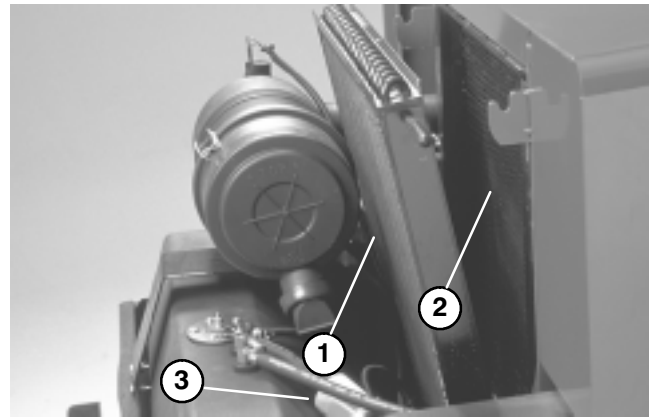

**Figure 33**

1. Oil Cooler
2. Radiator
3. Inline Fuel Filter

2. Maintaining Cooling System – Capacity of the system is 3.7 gal. (14 L). Always protect cooling system with a 50/50 solution of water and ethylene glycol anti-freeze. DO NOT USE WATER ONLY IN COOLING SYSTEM.

A. After every 100 operating hours, tighten hose connections. Replace any deteriorated hoses.

B. After every 800 operating hours, drain and flush the cooling system. Add anti-freeze (refer to Check Cooling System).

## ALTERNATOR BELT

1. Condition and Tension – Check condition and tension of belt (Fig. 34) after every 100 operating hours.

A. Proper tension will allow 3/8 in. (10 mm) deflection when a force of 10 lbs. is applied on the belt midway between the pulleys.

B. If deflection is not 3/8 in. (10 mm), loosen alternator mounting bolts. Increase or decrease alternator belt tension and tighten bolts. Check deflection of belt again to assure tension is correct.

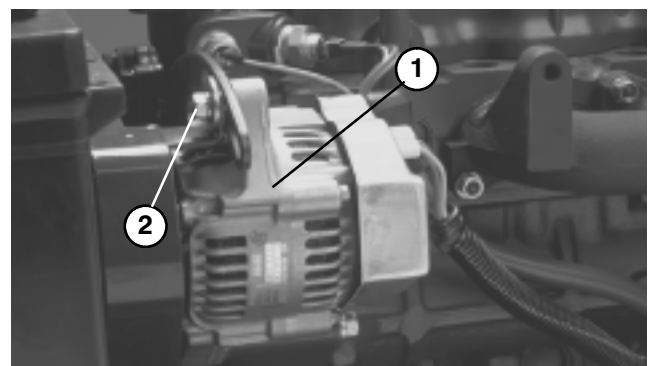

**Figure 34**

1. Alternator
2. Mounting Bolt

# MAINTENANCE

## BATTERY CARE

Check battery and cable connections after every 50 operating hours.

1. Turn engine off, release front engine cover latches and raise engine cover.
2. If battery or cables are damaged, worn or loose, make necessary repairs.
3. To clean the battery wash the entire case with solution of baking soda and water. Rinse with clear water. Coat the battery posts and cable connector with Grafo 112X (Skin-over) grease, Toro Part No. 505-47 or petroleum jelly to prevent corrosion.
4. Check electrolyte level in each cell.
5. Install battery cover and secure with capscrews.

## ADJUSTING HAND BRAKE & TRACTION SWITCHES

In time, the hand brake cable may stretch, causing the engine not to start. If this happens, adjust the cable (Fig. 35).

1. Pull brake lever to 3rd click.

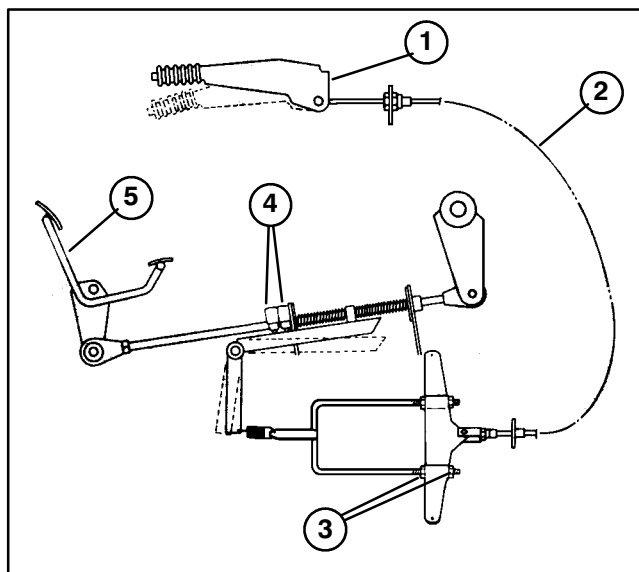

**Figure 35**

- |                   |                      |
|-------------------|----------------------|
| 1. Parking Brake  | 4. Traction Switches |
| 2. Brake Cable    | 5. Traction Pedal    |
| 3. U-bracket Nuts |                      |

2. Pull brake lever up one additional click.
3. Adjust four U-bracket nuts equally so spring has tension. Adjustment affects operation of traction switches.
4. Adjust four U-bracket nuts so engine will start and run when hand brake is at fourth click, but will not start or run when hand brake is at second click.

## ADDING HYDRAULIC OIL

Capacity of the hydraulic reservoir is approximately 9.3 gal. (35.2 L). With machine on a level surface, hydraulic oil level should be 1/4 to 1/2 inch below arrows on sight glass, when oil is cold. Warm oil should be even with arrows on sight glass (Fig. 36). If level is low, add hydraulic oil. Refer to Hydraulic Oil Specifications.

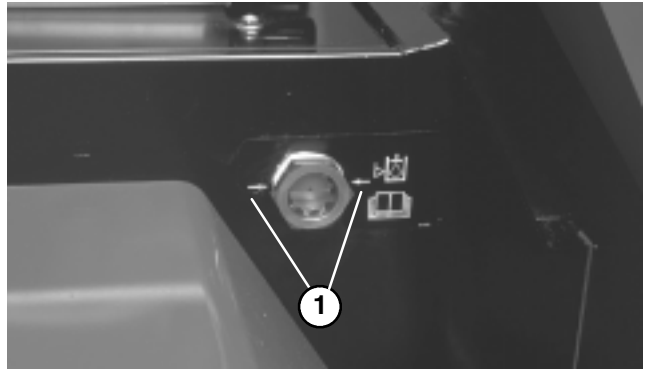

**Figure 36**

1. Sight Glass Arrows

1. Remove seat lock pin, raise seat and hold open with support rod.
2. Clean around reservoir cover (Fig. 37). Remove cover and add hydraulic oil until it is even with arrows on sight glass (Fig.36).

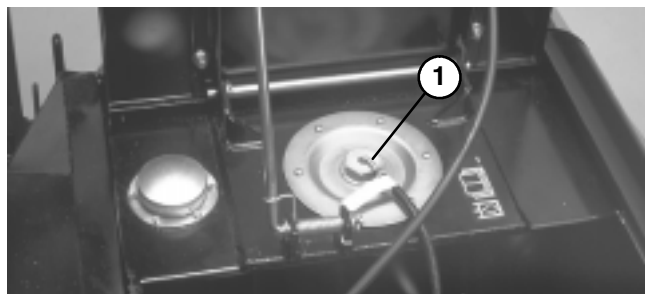

**Figure 37**

1. Reservoir Cover

**IMPORTANT: To prevent contamination, clean top of hydraulic oil containers before opening. Assure pour spout and funnel are clean.**

3. Install reservoir cover, lower seat and secure with lock pin.

## DRAINING WATER FROM HYDRAULIC RESERVOIR

After every 100 operating hours, drain water from hydraulic reservoir. Before draining, allow machine to set about 8 hours to allow water to settle to bottom of reservoir.

1. Open drain plug (Fig. 38) one-half turn and allow fluid to flow into drain pan until water is not noticed in hydraulic oil.

# MAINTENANCE

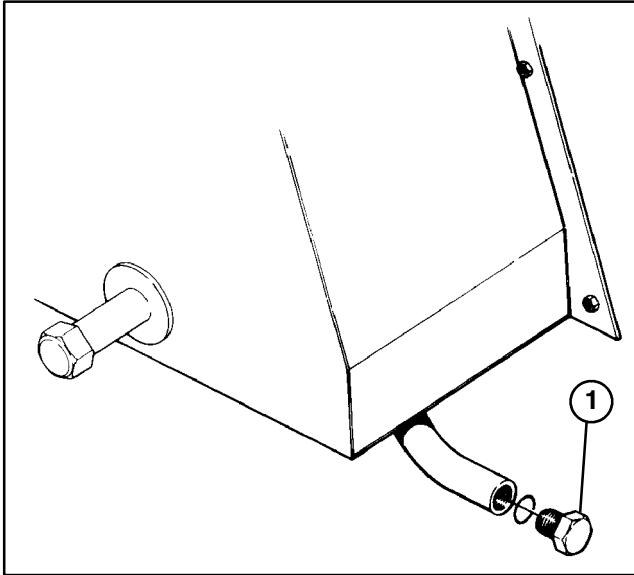

**Figure 38**  
1. Drain Plug

2. Tighten drain plug and add hydraulic oil, Refer to Adding Hydraulic Oil.

## CHANGING HYDRAULIC OIL

Normally, change hydraulic oil after every 2 years or 1500 operating hours. If oil becomes contaminated, contact your local TORO distributor because the system must be flushed. Contaminated oil looks milky or black when compared to clean oil.

1. Remove drain plug (Fig. 38) from reservoir and let hydraulic oil flow into drain pan. Tighten plug when hydraulic oil stops draining.
2. Fill reservoir with approximately 9.3 gallons of hydraulic oil. Refer to Hydraulic Oil Specifications.

**IMPORTANT: Use only hydraulic oils specified. Other fluids could cause system damage.**

3. Install reservoir cover, lower seat and secure with lock pin. Start engine, run slowly and use all hydraulic controls to distribute hydraulic oil throughout the system. Also check for leaks. Then stop the engine.
4. With cutting units up and oil warm, look into sight glass (Fig. 36). If hydraulic oil is not even with arrows, add enough to raise to proper level. Do not fill full if oil is cold.

## REPLACING HYDRAULIC FILTER

Initially, change filter after the first 50 operating hours, thereafter, every 800 operating hours, annually, or on indication.

Use Toro replacement filter (Part No. 86-6110).

**IMPORTANT: Use of any other filter may void the warranty on some components.**

1. Remove seat lock pin, raise seat and hold open with support rod. Also remove panel (secured with magnets) ahead of the seat.
2. Clean area around filter mounting area (Fig. 39). Place drain pan under filter and remove filter.
3. Lubricate new filter gasket and fill the filter with hydraulic oil.
4. Assure filter mounting area is clean. Screw filter on until gasket contacts mounting plate. Then tighten filter one-half turn.
5. Start engine and let it run slowly for about two minutes to purge air from the system. Stop the engine and check for leaks.

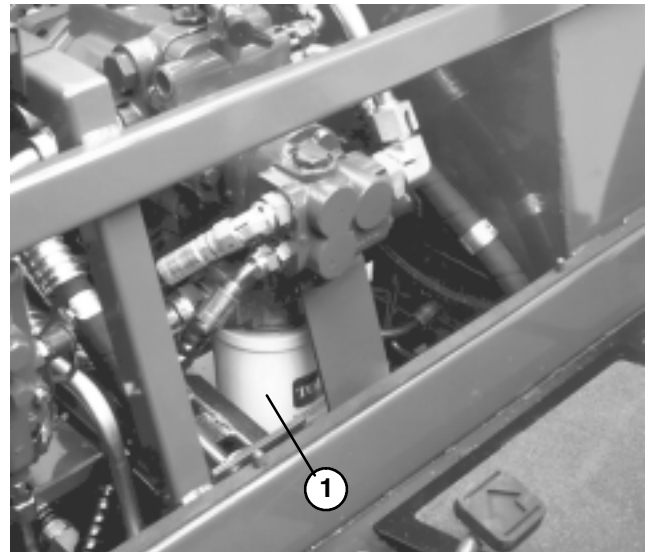

**Figure 39**  
1. Hydraulic Filter

6. Look into sight glass (Fig. 36). Hydraulic oil level should be even with arrows when oil is warm. If level is low, add hydraulic oil to the reservoir. Refer to Hydraulic Oil Specifications.

**Note:** Under certain conditions, a bypass valve in the filter mounting plate allows oil to bypass the filter. Before the filter starts to bypass a warning light on the steering console will illuminate. The warning light may come on momentarily when the oil is cold. If the light does not go out after the oil is warm, the filter is clogged or an electrical problem exists. Correct problem before commencing operation.

# MAINTENANCE

## REPLACING HYDRAULIC SYSTEM BREATHER

Change hydraulic system breather after every 800 operating hours, or annually, whichever comes first. More often in extremely dusty or dirty conditions.

1. Release latches and open engine cover.
2. Clean around the breather and unscrew it with a wrench (Fig. 40). Install new breather.



**Figure 40**  
1. Breather

3. Close engine cover and latch securely.

## CHECKING HYDRAULIC LINES AND HOSES

Check hydraulic lines and hoses daily for leaks, kinked lines, loose mounting supports, wear, loose fittings, weather deterioration and chemical deterioration. Make all necessary repairs before operating.

## HYDRAULIC SYSTEM TEST PORTS

The test ports (Fig. 41 & 42) are used to test the hydraulic circuits. Check all pressures when engine is at full speed and hydraulic oil is at normal operating temperature. Contact your local Toro distributor for assistance.

1. Traction Forward and Reverse (Fig. 41) (behind wheel motors) has a normal relief setting of approximately 5300 psi and 50 – 150 psi charge pressure. Use a gauge with 7500 – 10,000 psi full scale rating.

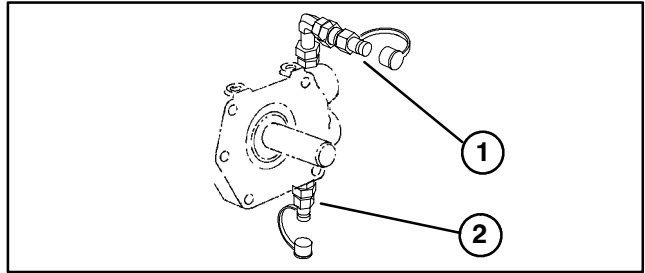

**Figure 41**

1. Traction Forward
2. Traction Reverse

2. Cutting unit Counterbalance has adjustable pressure.

Normal Setting      Hot Oil: 500–550 psi  
Cold Oil: 600–650 psi

Maximum Hill Climbing Setting  
Hot Oil: 550+ psi  
Cold Oil: 650+ psi

Maximum Quality of Cut Setting  
Hot Oil: 500 psi  
Cold Oil: 600 psi

Lift circuit relief pressure is approximately 2650 psi when counterbalance setting is 550 psi.

**Note:** Changes in counterbalance setting will effect the lift circuit relief pressure.

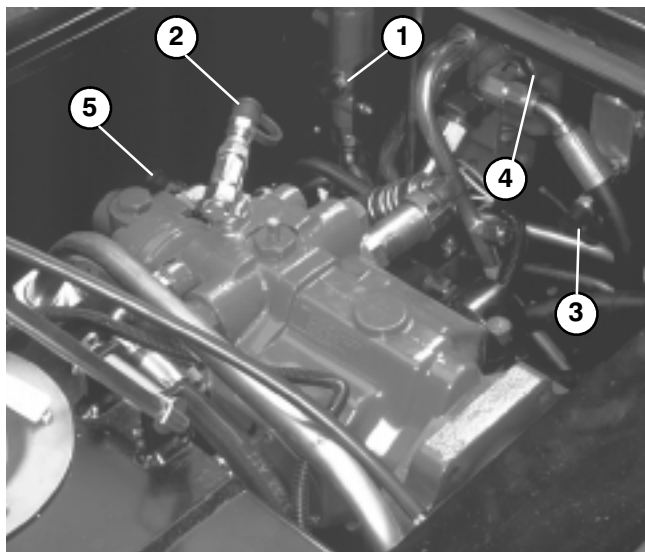

**Figure 42**

1. Lift/relief Circuit
2. Charge Pressure Circuit
3. Cutting Unit Counterbalance
4. Cutting Unit Circuit
5. Steering Circuit

3. Cutting Unit Circuit has a normal relief setting of approximately 2700–3000 psi.

4. Steering Circuit has a normal relief setting of approximately 1500 psi.

# MAINTENANCE

5. Lift/relief Circuit has a normal relief setting of approximately 2650–2750 psi.

6. Charge Pressure Circuit has a normal relief setting of approximately 100–150 psi.

## REAR WHEEL TOE-IN

After every 800 operating hours or annually, check rear wheel toe-in.

1. Measure center-to-center distance (at axle height) at front and rear of steering tires (Fig. 43). Front measurement must be 1/8 in. less than rear measurement.



Figure 43

2. Loosen clamps at both ends of tie rods (Fig. 44).

3. Rotate tie rod to move front of tire inward or outward.

4. Tighten tie rod clamps when adjustment is correct.

**Note:** Make sure tie rod clamps are positioned so they do not interfere with steering linkage.

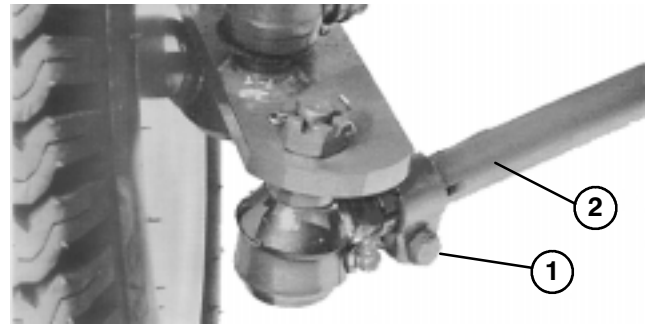

Figure 44

1. Clamp 2. Tie Rod

## CHECKING PLANETARY GEAR DRIVE

Initially, check oil level after 50 operating hours and check every 800 hours thereafter. Oil capacity is approximately 30 oz. (885 ml) high quality SAE 80–90 wt. Gear Lube (ISO 150/220).

1. To check the oil level, the oil should be at the bottom of the check/drain plug hole (Fig. 45) when the hole is placed in the 3 o'clock or 9 o'clock position. The traction unit must be on level ground when making this check.

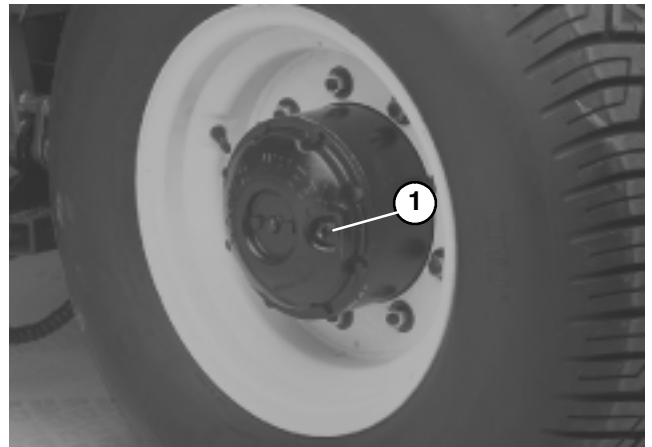

Figure 45

1. Check/Drain Plug

## ENGINE VALVE CLEARANCE

1. Adjust every 800 operating hours.





# MAINTENANCE SCHEDULE

## Minimum Recommended Maintenance Intervals

Maintenance Procedure	Maintenance Interval & Service				
Lubricate Reel Control Valve Grease Fitting Lubricate Reel Speed Valve with Oil Lubricate All Grease Fittings Check Battery Condition and Connections	Every 50hrs	Every 100hrs	Every 200hrs	Every 400hrs	Every 800hrs
‡ Change Engine Oil and Filter Drain Water from Hydraulic Tank † Check Engine Fan and Alternator Belt Inspect Cooling System Hoses Inspect Cutting Unit Reel Drive Belts † Torque Wheel Lug Nuts Service Air Cleaner Replace Fuel Filters Inspect Fuel Lines and Connections ‡ Check Engine RPM (idle and full throttle)					
Drain and Clean Fuel Tank ‡ Replace Hydraulic Oil Filter ‡ Adjust Valves Replace Hydraulic Tank Breather ‡ Change Front Planetary Gear Lube Pack Rear Wheel Bearings Check Rear Wheel Toe-in					
† Initial break in at 10 hours ‡ Initial break in at 50 hours					
Replace Moving Hydraulic Hoses Replace Safety Switches Coolant System – Flush/Replace Fluid Change Hydraulic Oil					

**Annual Recommendations:**  
*Items listed are recommended every 1500 hours or 2 years, whichever occurs first.*

(See Operator's and Service Manual for specifications and procedures)



# PRODUCT IDENTIFICATION

The traction unit has two identification numbers: a model number and a serial number that are stamped into a plate. The identification plate is located just ahead of the right front wheel. In any correspondence concerning the traction unit, supply the model and serial numbers to ensure correct information and replacement parts are obtained.

To order replacement parts from an Authorized TORO

Distributor supply the following information:

1. Model and serial numbers of the traction unit.
2. Part number, description and quantity of parts desired.

**Note:** Do not order by reference number if a parts catalog is being used; use the part number.

# NOTES

# NOTES



# The Toro General Commercial Products Warranty

## A Two-Year Limited Warranty

### Conditions and Products Covered

The Toro Company and its affiliate, Toro Warranty Company, pursuant to an agreement between them, jointly warrant your 1996 or newer Toro Commercial Product ("Product") purchased after January 1, 1997, to be free from defects in materials or workmanship for two years or 1500 operational hours\*, whichever occurs first. Where a warrantable condition exists, we will repair the Product at no cost to you including diagnosis, labor, parts, and transportation. This warranty begins on the date the Product is delivered to the original retail purchaser.

\* Product equipped with hour meter

### Instructions for Obtaining Warranty Service

You are responsible for notifying the Commercial Products Distributor or Authorized Commercial Products Dealer from whom you purchased the Product as soon as you believe a warrantable condition exists.

If you need help locating a Commercial Products Distributor or Authorized Dealer, or if you have questions regarding your warranty rights or responsibilities, you may contact us at:

Toro Commercial Products Service Department  
Toro Warranty Company  
8111 Lyndale Avenue South  
Bloomington, MN 55420-1196  
612-888-8801  
800-982-2740  
E-mail: [commercial.service@toro.com](mailto:commercial.service@toro.com)

### Owner Responsibilities

As the Product owner, you are responsible for required maintenance and adjustments stated in your operator's manual. Failure to perform required maintenance and adjustments can be grounds for disallowing a warranty claim.

### Items and Conditions Not Covered

Not all product failures or malfunctions that occur during the warranty period are defects in materials or workmanship. This express warranty does not cover:

- Product failures which result from the use of non-Toro replacement parts, or from installation and use of add-on, modified, or unapproved accessories.
- Product failures which result from failure to perform required maintenance and/or adjustments.
- Product failures which result from operating the Product in an abusive, negligent or reckless manner.
- Parts subject to consumption through use unless found to be defective. Examples of parts which are consumed, or used up, during normal Product operation include, but are not limited to, blades, reels, bedknives, tines, spark plugs, castor wheels, tires, filters, belts, etc.

- Failures caused by outside influence. Items considered to be outside influence include, but are not limited to, weather, storage practices, contamination, use of unapproved coolants, lubricants, additives, or chemicals, etc.
- Normal "wear and tear" items. Normal "wear and tear" includes, but is not limited to, damage to seats due to wear or abrasion, worn painted surfaces, scratched decals or windows, etc.

### Parts

Parts scheduled for replacement as required maintenance are warranted for the period of time up to the scheduled replacement time for that part.

Parts replaced under this warranty become the property of Toro. Toro will make the final decision whether to repair any existing part or assembly or replace it. Toro may use factory remanufactured parts rather than new parts for some warranty repairs.

### General Conditions

Repair by an Authorized Toro Distributor or Dealer is your sole remedy under this warranty.

**Neither The Toro Company nor Toro Warranty Company is liable for indirect, incidental or consequential damages in connection with the use of the Toro Products covered by this warranty, including any cost or expense of providing substitute equipment or service during reasonable periods of malfunction or non-use pending completion of repairs under this warranty. Except for the Emissions warranty referenced below, if applicable, there is no other express warranty. All implied warranties of merchantability and fitness for use are limited to the duration of this express warranty.**

Some states do not allow exclusions of incidental or consequential damages, or limitations on how long an implied warranty lasts, so the above exclusions and limitations may not apply to you.

This warranty gives you specific legal rights, and you may also have other rights which vary from state to state.

**Note regarding engine warranty:** The Emissions Control System on your Product may be covered by a separate warranty meeting requirements established by the U.S. Environmental Protection Agency (EPA) and/or the California Air Resources Board (CARB). The hour limitations set forth above do not apply to the Emissions Control System Warranty. Refer to the Engine Emission Control Warranty Statement printed in your operator's manual or contained in the engine manufacturer's documentation for details.

### Countries Other than the United States or Canada

Customers who have purchased Toro products exported from the United States or Canada should contact their Toro Distributor (Dealer) to obtain guarantee policies for your country, province, or state. If for any reason you are dissatisfied with your Distributor's service or have difficulty obtaining guarantee information, contact the Toro importer. If all other remedies fail, you may contact us at Toro Warranty Company.