



**Count on it.**

**Operator's Manual**

**Groundsmaster® 4500-D and  
4700-D Rotary Mower**

Model No. 30881—Serial No. 403365001 and Up

Model No. 30882—Serial No. 403365001 and Up



This product complies with all relevant European directives; for details, please see the separate product specific Declaration of Conformity (DOC) sheet.

Genuine Toro spark arresters are approved by the USDA Forestry Service.

It is a violation of California Public Resource Code Section 4442 or 4443 to use or operate the engine on any forest-covered, brush-covered, or grass-covered land unless the engine is equipped with a spark arrester, as defined in Section 4442, maintained in effective working order or the engine is constructed, equipped, and maintained for the prevention of fire.

Please refer to the engine manufacturer's information included with the machine

**⚠ WARNING**

**CALIFORNIA**  
**Proposition 65 Warning**

**Diesel engine exhaust and some of its constituents are known to the State of California to cause cancer, birth defects, and other reproductive harm.**

**Battery posts, terminals, and related accessories contain lead and lead compounds, chemicals known to the State of California to cause cancer and reproductive harm. Wash hands after handling.**

**Use of this product may cause exposure to chemicals known to the State of California to cause cancer, birth defects, or other reproductive harm.**

# Introduction

This machine is a ride-on, rotary-blade lawn mower intended to be used by professional, hired operators in commercial applications. It is primarily designed for cutting grass on well-maintained lawns in parks, golf courses, sports fields, and on commercial grounds. It is not designed for cutting brush, mowing grass and other growth alongside highways, or for agricultural uses.

Read this information carefully to learn how to operate and maintain your product properly and to avoid injury and product damage. You are responsible for operating the product properly and safely.

You may contact Toro directly at [www.Toro.com](http://www.Toro.com) for product safety and operation training materials, accessory information, help finding a dealer, or to register your product.

Whenever you need service, genuine Toro parts, or additional information, contact an Authorized Service Dealer or Toro Customer Service and have the model and serial numbers of your product ready. **Figure 1** identifies the location of the model and serial numbers on the right front frame member of the product. Write the numbers in the space provided.

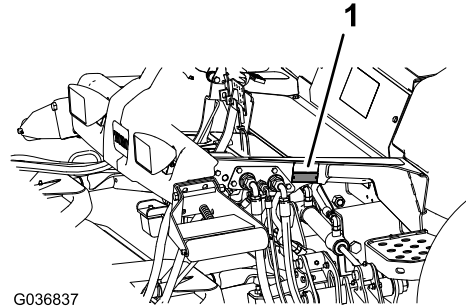

**Figure 1**

1. Model and serial number location

Model No. _____
Serial No. _____

This manual identifies potential hazards and has safety messages identified by the safety-alert symbol (**Figure 2**), which signals a hazard that may cause serious injury or death if you do not follow the recommended precautions.



**Figure 2**

1. Safety-alert symbol.

This manual uses 2 words to highlight information. **Important** calls attention to special mechanical information and **Note** emphasizes general information worthy of special attention.

# Contents

Safety .....	4	Maintenance Safety .....	53
General Safety .....	4	Preparing the Machine for Maintenance .....	53
Engine-Emission Certification .....	4	Lifting the Machine .....	53
Safety and Instructional Decals .....	5	Opening the Hood .....	54
Setup .....	11	Accessing the Hydraulic Lift	
1 Replacing the Warning Decal .....	11	Compartment .....	55
2 Installing the Hood Latch .....	11	Lubrication .....	55
3 Adjusting the Roller Scraper .....	13	Greasing the Bearings and Bushings .....	55
4 Installing the Mulching Baffle .....	13	Engine Maintenance .....	57
5 Preparing the Machine .....	13	Engine Safety .....	57
Product Overview .....	14	Servicing the Air Cleaner .....	57
Controls .....	14	Servicing the Engine Oil .....	58
Specifications .....	22	Servicing the Diesel-Oxidation Catalyst	
Machine Specifications .....	23	(DOC) and the Soot Filter .....	59
Cutting Unit Specifications .....	23	Fuel System Maintenance .....	60
Attachments/Accessories .....	23	Draining the Fuel Tank .....	60
Before Operation .....	24	Inspecting the Fuel Lines and	
Before Operation Safety .....	24	Connections .....	60
Checking the Engine-Oil Level .....	24	Servicing the Fuel-Water Separator .....	60
Checking the Cooling System .....	24	Servicing the Fuel Filter .....	61
Checking the Hydraulic System .....	24	Cleaning the Fuel-Pickup Tube Screen .....	61
Draining the Water Separator .....	24	Priming the Fuel System .....	62
Checking the Rear Axle and Gearbox for		Electrical System Maintenance .....	62
Leaks .....	24	Electrical System Safety .....	62
Filling the Fuel Tank .....	25	Checking the Battery Condition .....	62
Checking the Tire Pressure .....	26	Charging and Connecting the Battery .....	63
Checking the Torque of the Wheel Lug		Locating the Fuses .....	64
Nuts .....	26	Drive System Maintenance .....	65
Adjusting the Roll Bar .....	27	Checking for End-Play in the Planetary	
Adjusting the Height of Cut .....	28	Drives .....	65
Checking the Interlock Switches .....	28	Checking the Planetary Gear-Drive	
Checking the Blade-Stopping Time .....	29	Lubricant .....	65
Selecting a Blade .....	29	Changing the Planetary-Gear-Drive	
Choosing Accessories .....	30	Oil .....	66
During Operation .....	31	Checking the Rear Axle and Gearbox for	
During Operation Safety .....	31	Leaks .....	67
Starting the Engine .....	32	Checking the Rear-Axle Lubricant .....	67
Shutting Off the Engine .....	32	Changing the Rear-Axle Lubricant .....	68
Cutting Grass with the Machine .....	32	Checking the Rear-Axle-Gearbox	
Diesel Particulate Filter Regeneration .....	33	Lubricant .....	68
Understanding the Operating Characteristics		Checking the Rear Wheel Toe-In .....	69
of the Machine .....	45	Cooling System Maintenance .....	70
Operating the Engine-Cooling Fan .....	45	Cooling System Safety .....	70
Using Cruise Control .....	46	Checking the Cooling System .....	70
Using the Transport Latches .....	46	Cleaning the Cooling System .....	71
Operating Tips .....	46	Brake Maintenance .....	72
After Operation .....	48	Adjusting the Service Brakes .....	72
After Operation Safety .....	48	Belt Maintenance .....	72
Using the Cutting-Unit Storage Lanyard .....	48	Servicing the Alternator Belt .....	72
Hauling the Machine .....	49	Hydraulic System Maintenance .....	73
Pushing or Towing the Machine .....	49	Hydraulic System Safety .....	73
Locating the Tie-Down Points .....	50	Checking the Hydraulic-Fluid Level .....	73
Maintenance .....	51	Changing the Hydraulic Fluid .....	74
Recommended Maintenance Schedule(s) .....	51	Replacing the Hydraulic Filters .....	75
Daily Maintenance Checklist .....	52	Checking the Hydraulic Lines and	
Pre-Maintenance Procedures .....	53	Hoses .....	75
		Cutting Unit Maintenance .....	76
		Removing the Cutting Units .....	76

Installing the Cutting Units .....	76
Servicing the Front Roller .....	76
Blade Maintenance .....	77
Blade Safety .....	77
Servicing the Blade Plane .....	77
Removing and Installing the Cutting-Unit Blade(s) .....	78
Inspecting and Sharpening the Mower Blade(s) .....	79
Storage .....	80
Preparing for Seasonal Storage .....	80

# Safety

This machine has been designed in accordance with ANSI B71.4-2017 and EN ISO 5395:2013 when you install the CE decal and the hood latch.

## General Safety

This product is capable of amputating hands and feet and of throwing objects. Always follow all safety instructions to avoid serious personal injury.

Using this product for purposes other than its intended use could prove dangerous to you and bystanders.

- Read and understand the contents of this *Operator's Manual* before starting the engine.
- Use your full attention while operating the machine. Do not engage in any activity that causes distractions; otherwise, injury or property damage may occur.
- Do not put your hands or feet near moving components of the machine.
- Do not operate the machine without all guards and other safety protective devices in place and working on the machine.
- Keep clear of any discharge opening. Keep bystanders and pets a safe distance away from the machine.
- Keep children out of the operating area. Never allow children to operate the machine.
- Stop the machine, shut off the engine, remove the key, and wait for all moving parts to stop before servicing, fueling, or unclogging the machine.

Improperly using or maintaining this machine can result in injury. To reduce the potential for injury, comply with these safety instructions and always pay attention to the safety-alert symbol , which means Caution, Warning, or Danger—personal safety instruction. Failure to comply with these instructions may result in personal injury or death.

You can find additional safety information where needed throughout this *Operator's Manual*.

## Engine-Emission Certification

The engine in this machine is EPA Tier 4i and EU Stage 3b emissions compliant.

# Safety and Instructional Decals



Safety decals and instructions are easily visible to the operator and are located near any area of potential danger. Replace any decal that is damaged or missing.

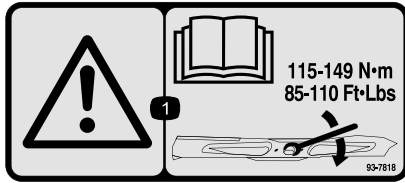

93-7818

decal93-7818

1. Warning—read the *Operator's Manual* for instructions on torquing the blade bolt/nut to 115 to 149 N·m (85 to 110 ft-lb).



107-1971

decal107-1971



98-4387

decal98-4387

1. Warning—wear hearing protection.

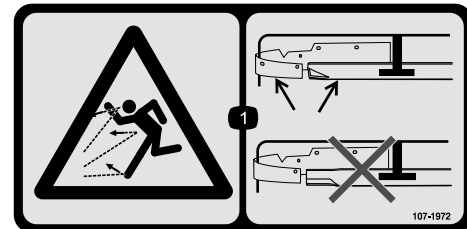

107-1972

decal107-1972

1. Thrown object hazard—use a standard blade when the mulch baffle is installed; do not use a high-lift blade when the mulch baffle is installed.

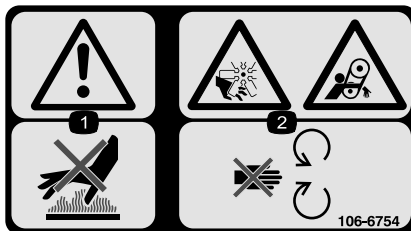

106-6754

decal106-6754

1. Warning—do not touch the hot surface.
2. Cutting/dismemberment hazard, fan and entanglement hazard, belt—stay away from moving parts.

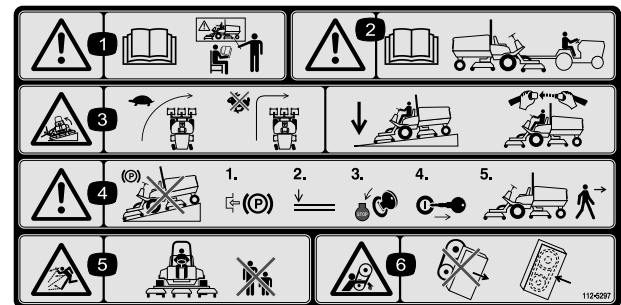

112-5297

decal112-5297

1. Warning—read the *Operator's Manual*, do not operate this machine unless you are trained.
2. Warning—read the *Operator's Manual* before towing the machine.
3. Tipping hazard—slow machine before turning, do not turn at high speeds; lower the cutting unit when driving down slopes; use a rollover protection system and wear the seat belt.
4. Warning—do not park the machine on slopes; engage the parking brake, lower the cutting units, shut off the engine, and remove the key before leaving the machine.
5. Thrown object hazard—keep bystanders a safe distance away from the machine.
6. Entanglement hazard, belt—stay away from moving parts; keep all guards and shields in place.



106-6755

decal106-6755

1. Engine coolant under pressure.
2. Explosion hazard—read the *Operator's Manual*.
3. Warning—do not touch the hot surface.
4. Warning—read the *Operator's Manual*.

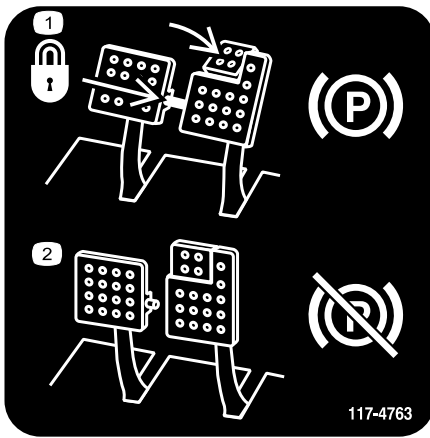

117-4763

decal117-4763

1. To engage the parking brake, secure the brake pedals with the locking pin, press the parking-brake pedals and engage the toe pedal.
2. To disengage the parking brake, disengage the locking pin and release the pedals.

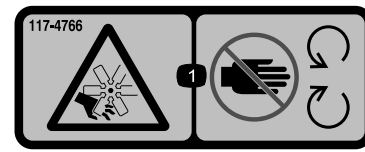

117-4766

decal117-4766

1. Cutting/dismemberment hazard; fan—stay away from moving parts, keep all guards and shields in place.

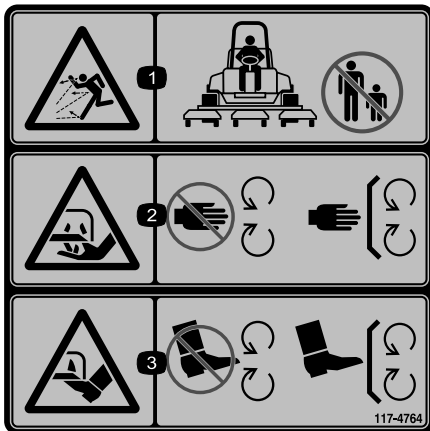

117-4764

decal117-4764

1. Thrown object hazard—keep bystanders a safe distance away from the machine.
2. Cutting hazard of hand, mower blade—stay away from moving parts, keep all guards and shields in place.
3. Cutting hazard of foot, mower blade—stay away from moving parts, keep all guards and shields in place.

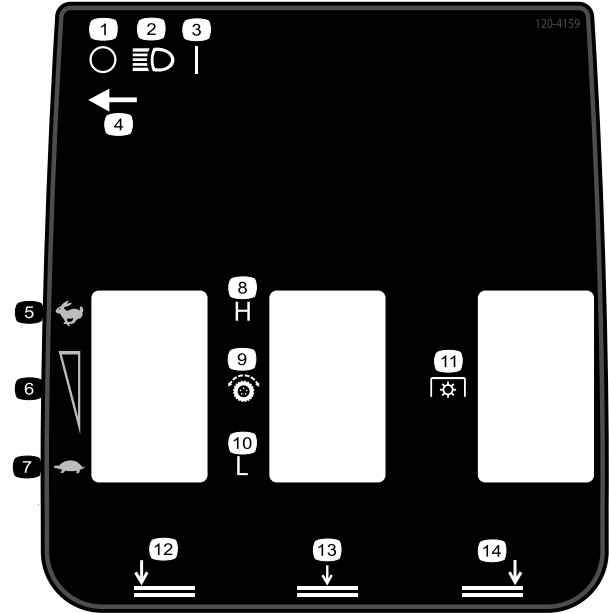

120-4159

decal120-4159

- |                              |                                 |
|------------------------------|---------------------------------|
| 1. Off                       | 8. High                         |
| 2. Lights                    | 9. Traction drive               |
| 3. On                        | 10. Low                         |
| 4. Light-switch location     | 11. Power takeoff (PTO)         |
| 5. Fast                      | 12. Lower, left cutting unit    |
| 6. Variable-speed adjustment | 13. Lower, center cutting units |
| 7. Slow                      | 14. Lower, right cutting unit   |

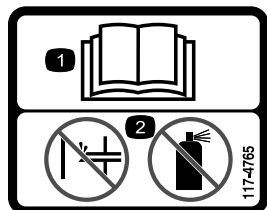

117-4765

decal117-4765

1. Read the *Operator's Manual*.
2. Do not use starting aids.

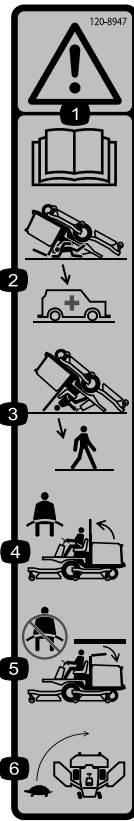

**120-8947**

decal120-8947

1. Warning—read the *Operator's Manual*.
2. There is no rollover protection when the roll bar is down.
3. There is rollover protection when the roll bar is up.
4. If the roll bar is raised, wear the seat belt.
5. If the roll bar is lowered, do not wear the seat belt.
6. Drive slowly when turning.

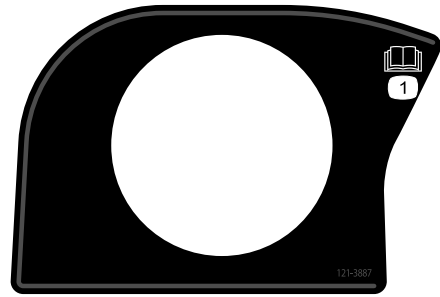

**121-3887**

decal121-3887

1. Read the *Operator's Manual*.

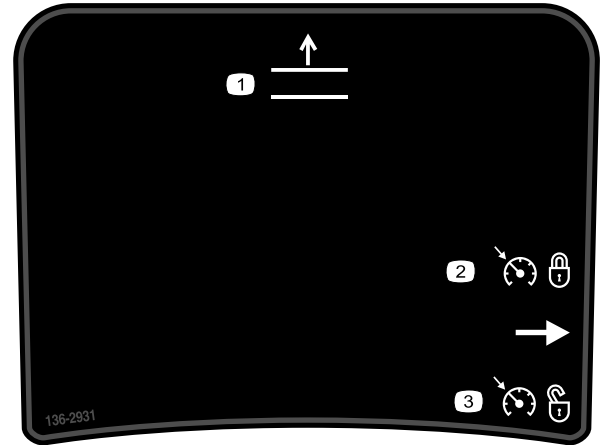

**136-2931**

decal136-2931

For Groundsmaster 4500 Only

1. Raise the decks.
2. Set the cruise control.
3. Disengage the cruise control.

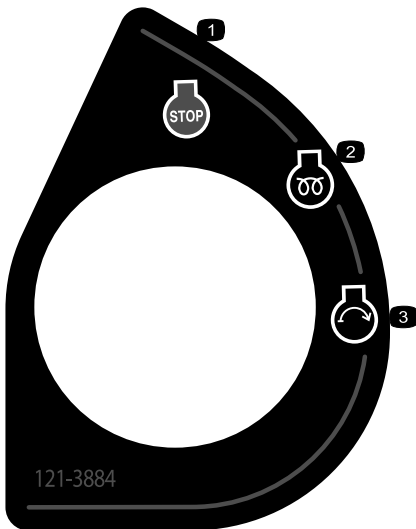

**121-3884**

decal121-3884

1. Engine—stop
2. Engine—preheat
3. Engine—start

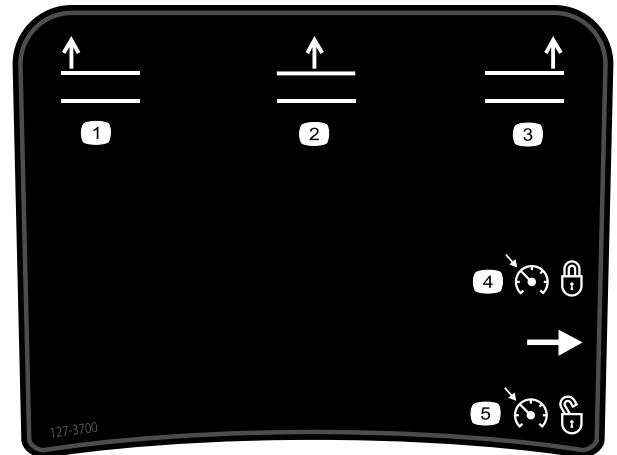

**127-3700**

decal127-3700

For Groundsmaster 4700 Only

1. Raise the left cutting unit.
2. Raise the center cutting units.
3. Raise the right cutting unit.
4. Set the cruise control.
5. Disengage the cruise control.

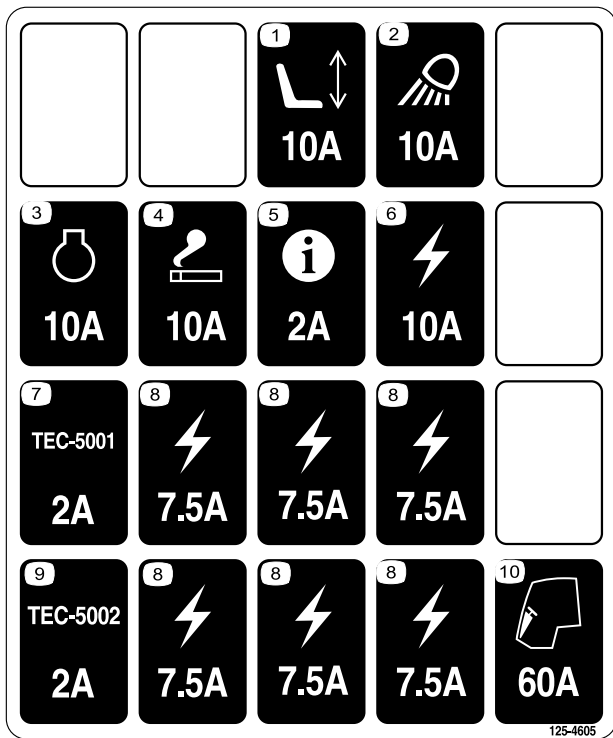

125-4605

decal125-4605

1. Power seat (10 A)
2. Work light (10 A)
3. Engine (10 A)
4. Power port (10 A)
5. Infocenter (2 A)
6. Power supplied (10 A)
7. GM4700 controller (2 A)
8. Power supplied (7.5 A)
9. GM4500 controller (2 A)
10. Cab (60 A)



decalbatterysymbols

### Battery Symbols

Some or all of these symbols are on your battery

1. Explosion hazard
2. No fire, open flame, or smoking
3. Caustic liquid/chemical burn hazard
4. Wear eye protection.
5. Read the *Operator's Manual*.
6. Keep bystanders a safe distance away from the battery.
7. Wear eye protection; explosive gases can cause blindness and other injuries.
8. Battery acid can cause blindness or severe burns.
9. Flush eyes immediately with water and get medical help fast.
10. Contains lead; do not discard

**GROUNDMASTER 4500/4700**  
QUICK REFERENCE AID

**CHECK/SERVICE (DAILY)**

1. ENGINE OIL LEVEL
2. HYDRAULIC OIL FLUID LEVEL
3. ENGINE COOLANT LEVEL
4. FUEL - DIESEL ONLY
5. FUEL/WATER SEPARATOR
6. RADIATOR SCREEN
7. AIR CLEANER
8. BRAKE FUNCTION
9. TIRE PRESSURE: 20 PSI/1.40 BAR  
WHEEL NUT TORQUE: 93 FT/LB (127 N·m)

**CHECK/SERVICE** (SEE OPERATOR'S MANUAL)

10. BATTERY
11. BELTS (FAN, ALT)
12. PLANETARY GEAR DRIVE
13. INTERLOCK SYSTEM
14. REAR AXLE
15. ENGINE OIL DRAIN
16. GREASING

**SPECIFICATIONS/CHANGE INTERVALS**

SEE OPERATOR'S MANUAL FOR INITIAL CHANGES	FLUID TYPE	CAPACITY	CHANGE INTERVAL		FILTER PART NO.
			FLUID	FILTER	
① ENGINE OIL	15W-40 CH-4	6 QUARTS	250 HOURS	250 HOURS	125-7025
	15W-40 CH-4	6 QUARTS			
② HYDRAULIC FLUID	ISO VG 46/68	8.25 GALLONS	800 HOURS	800 HOURS	75-1310
③ HYDRAULIC FILTER				800 HOURS	94-2621
④ HYDRAULIC BREATHER				800 HRS/YRLY	115-9793
⑤ FUEL SYSTEM	> 32 F	NO. 2 DIESEL	800 HOURS	400 HOURS/ YEARLY	110-9049 (017)
	< 32 F	NO. 1 DIESEL	22 GALLONS	400 HOURS/ YEARLY	125-2915 (018)
⑥ ENGINE COOLANT	50% WATER 50% ETHYLENE GLYCOL	9 QUARTS	DRAIN & FLUSH EVERY 2 YRS.		
⑦ PRIMARY AIR FILTER				REVERSE PACKING	108-3814
⑧ SAFETY AIR FILTER				SEE OPERATOR'S MANUAL	108-3816
⑨ REAR AXLE	85W-140	80 OUNCES	800 HOURS		110-4812 (01)
⑩ PLANETARY DRIVE	85W-140	16 OUNCES	800 HOURS		

125-4606

decal125-4606

1. Read the *Operator's Manual* for information on maintenance.

**⚠ WARNING: Cancer and Reproductive Harm - [www.P65Warnings.ca.gov](http://www.P65Warnings.ca.gov).**  
For more information, please visit [www.ttcocalprop65.com](http://www.ttcocalprop65.com)

**CALIFORNIA SPARK ARRESTER WARNING**  
Operation of this equipment may create sparks that can start fires around dry vegetation. A spark arrester may be required. The operator should contact local fire agencies for laws or regulations relating to fire prevention requirements.

decal133-8062

133-8062



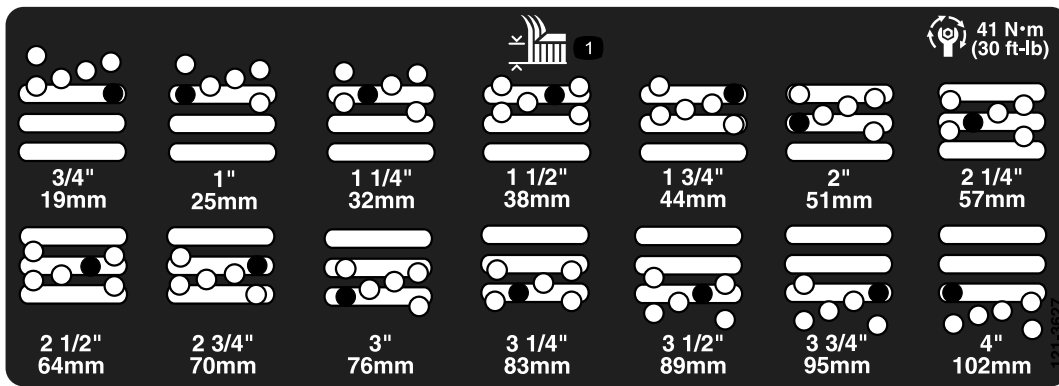

121-3627

decal121-3627

1. Height-of-cut settings

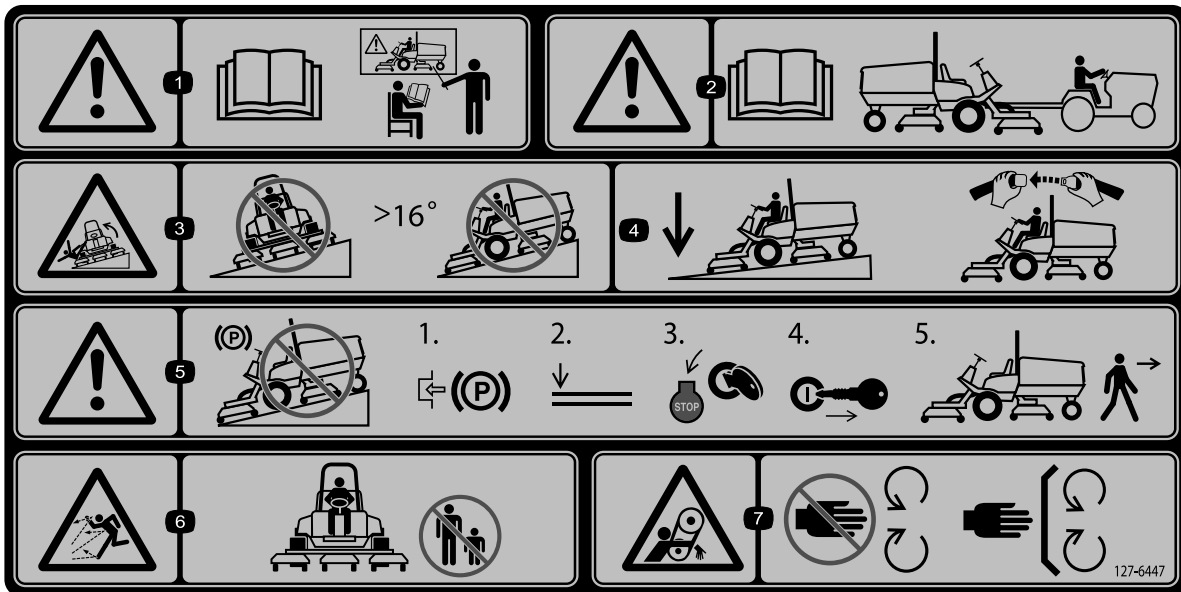

127-6447

decal127-6447

**Note:** This machine complies with the industry standard stability test in the static lateral and longitudinal tests with the maximum recommended slope indicated on the decal. Review the instructions for operating the machine on slopes in the *Operator's Manual* as well as the conditions in which you would operate the machine to determine whether you can operate the machine in the conditions on that day and at that site. Changes in the terrain can result in a change in slope operation for the machine.

- |  |  |   |  |
|--|--|---|--|
| <p>1. Warning—read the <i>Operator's Manual</i>; all operators should be trained before operating the machine.</p> | <p>3. Tipping hazard—do not drive on slopes greater than 16°.</p>  | <p>5. Warning—do not park on slopes; engage the parking brake, lower the cutting units, shut off the engine, and remove the key before leaving the machine.</p> | <p>7. Entanglement hazard, belt—stay away from moving parts; keep all guards and shields in place.</p> |
| <p>2. Warning—read the <i>Operator's Manual</i> for towing information.</p>  | <p>4. Keep the cutting units lowered while driving down slopes; always wear a seatbelt when operating the machine.</p> | <p>6. Thrown object hazard—keep bystanders away.</p>  |  |

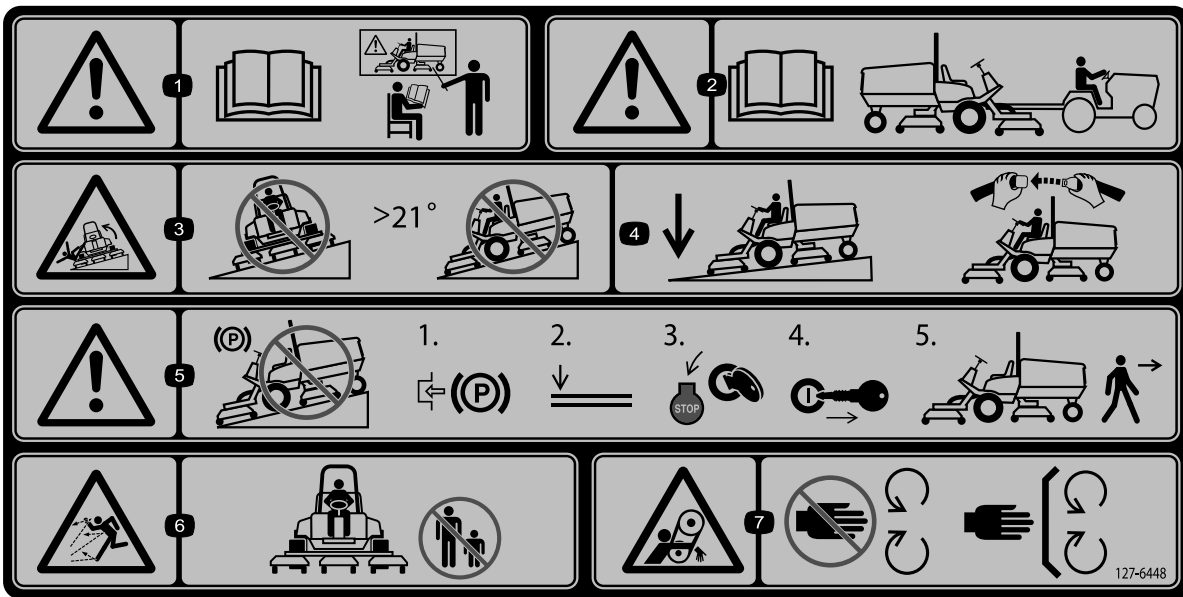

decal127-6448

### 127-6448

**Note:** This machine complies with the industry standard stability test in the static lateral and longitudinal tests with the maximum recommended slope indicated on the decal. Review the instructions for operating the machine on slopes in the *Operator's Manual* as well as the conditions in which you would operate the machine to determine whether you can operate the machine in the conditions on that day and at that site. Changes in the terrain can result in a change in slope operation for the machine.

- |  |  |   |  |
|--|--|---|--|
| <p>1. Warning—read the <i>Operator's Manual</i>; all operators should be trained before operating the machine.</p> | <p>3. Tipping hazard—do not drive on slopes greater than 21°.</p>  | <p>5. Warning—do not park on slopes; engage the parking brake, lower the cutting units, shut off the engine, and remove the key before leaving the machine.</p> | <p>7. Entanglement hazard, belt—stay away from moving parts; keep all guards and shields in place.</p> |
| <p>2. Warning—read the <i>Operator's Manual</i> for towing information.</p>  | <p>4. Keep the cutting units lowered while driving down slopes; always wear a seatbelt when operating the machine.</p> | <p>6. Thrown object hazard—keep bystanders away.</p>  |  |

# Setup

## Loose Parts

Use the chart below to verify that all parts have been shipped.

Procedure	Description	Qty.	Use
<b>1</b>	Warning decal	1	Replace the warning decal (CE machines only).
<b>2</b>	Hood-latch bracket Rivet Washer Screw (1/4 x 2 inches) Locknut (1/4 inch)	1 2 1 1 1	Install the hood latch (CE machines only).
<b>3</b>	No parts required	–	Adjust the roller scraper (optional).
<b>4</b>	No parts required	–	Install the mulching baffle (optional).
<b>5</b>	No parts required	–	Prepare the machine.

## Media and Additional Parts

Description	Qty.	Use
Operator's Manual	1	Review before operating the machine.
Engine owner's manual	1	Refer to the manual for additional maintenance information.
Operator Training Material	1	Review before operating the machine.

**Note:** Determine the left and right sides of the machine from the normal operating position.

# 1

## Replacing the Warning Decal

### CE Machines Only

Parts needed for this procedure:

1	Warning decal
---	---------------

### Procedure

On machines requiring European CE compliance, replace the warning decal Part No. 112-5297 with warning decal Part No. 127-6447 (for 4500 series machines) or decal Part No. 127-6448 (for 4700 series machines).

# 2

## Installing the Hood Latch

### CE Machines Only

Parts needed for this procedure:

1	Hood-latch bracket
2	Rivet
1	Washer
1	Screw (1/4 x 2 inches)
1	Locknut (1/4 inch)

### Procedure

1. Unhook the hood latch from the hood-latch bracket.

- Remove the 2 rivets securing the hood-latch bracket to the hood (Figure 3).

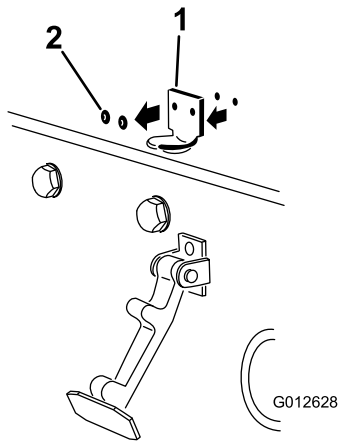
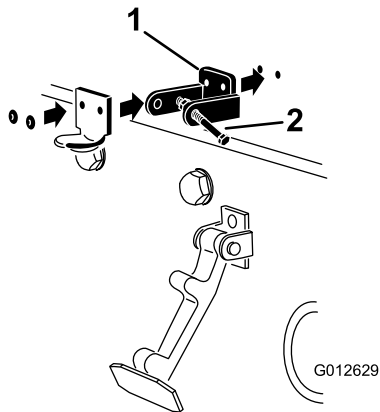

**Figure 3**

- Hood-latch bracket
- Rivets

- Remove the hood-latch bracket from the hood.
- While aligning the mounting holes, position the CE lock bracket and the hood-latch bracket onto the hood (Figure 4).

**Note:** The lock bracket must be against the hood. Do not remove the bolt and nut from the lock-bracket arm.



**Figure 4**

- CE lock bracket
- Bolt and nut

- Align the washers with the holes on the inside of the hood.
- Rivet the brackets and the washers to the hood (Figure 4).
- Hook the latch onto the hood-latch bracket (Figure 5).

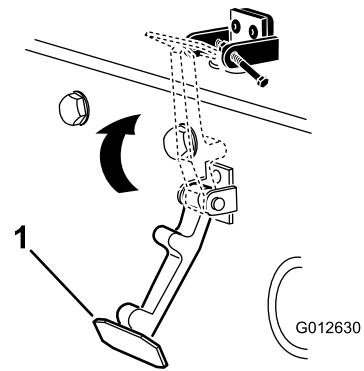

**Figure 5**

- Hood latch

- Install the bolt into the other arm of the hood-latch bracket to lock the latch in position (Figure 6). Tighten the bolt but do not tighten the nut.

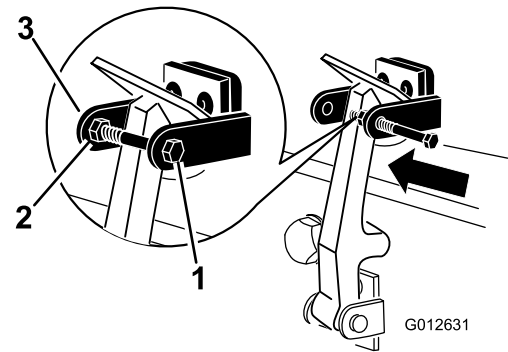

**Figure 6**

- Bolt
- Nut
- Arm of hood-latch bracket

# 3

## Adjusting the Roller Scraper

### Optional

No Parts Required

### Procedure

The optional rear roller scraper functions best when there is an even gap of 0.5 to 1 mm (0.02 to 0.04 inch) between the scraper and the roller.

1. Loosen the grease fitting and the mounting screw (Figure 7).

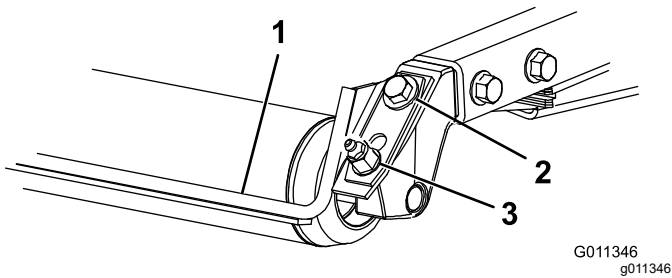

Figure 7

1. Roller scraper
2. Mounting screw
3. Grease fitting

2. Slide the scraper up or down until you obtain a gap of 0.5 to 1 mm (0.02 to 0.04 inch) between the rod and the roller.
3. Tighten the grease fitting and screw to 41 N·m (30 ft·lb) in an alternating sequence.

# 4

## Installing the Mulching Baffle

### Optional

No Parts Required

### Procedure

1. Thoroughly clean debris from the mounting holes on the rear wall and left wall of the chamber.
2. Install the mulching baffle in the rear opening and secure it with 5 flange-head bolts (Figure 8).

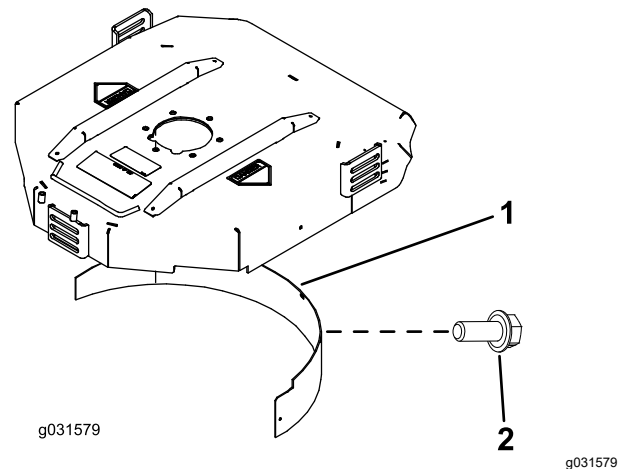

Figure 8

1. Mulching baffle
2. Flange-head bolt

3. Verify that the mulching baffle does not interfere with the tip of the blade and does not protrude inside the surface of the rear chamber wall.

### **⚠ DANGER**

Using the high-lift blade with the mulching baffle could cause the blade to break, resulting in personal injury or death.

Do not use the high-lift blade with the baffle.

# 5

## Preparing the Machine

No Parts Required

### Procedure

1. Park the machine on a level surface.
2. Lower the cutting units.
3. Engage the parking brake.
4. Shut off the engine and remove the key.
5. Check the tire pressure before use; refer to [Checking the Tire Pressure \(page 26\)](#).

**Important:** Maintain pressure in all tires to ensure a good quality-of-cut and proper machine performance. Do not underinflate the tires.

6. Check the rear-axle lubricant level before you start the engine for the first time; refer to [Checking the Rear-Axle Lubricant \(page 67\)](#).
7. Check the engine-oil level before starting the engine; refer to [Checking the Engine-Oil Level \(page 58\)](#).
8. Check the hydraulic-fluid level before starting the engine; refer to [Checking the Hydraulic-Fluid Level \(page 73\)](#).
9. Check the cooling system before starting the engine; refer to [Checking the Hydraulic-Fluid Level \(page 73\)](#).
10. Grease the machine before use; refer to [Greasing the Bearings and Bushings \(page 55\)](#). Failure to properly grease the machine will result in premature failure of critical parts.

## Product Overview Controls

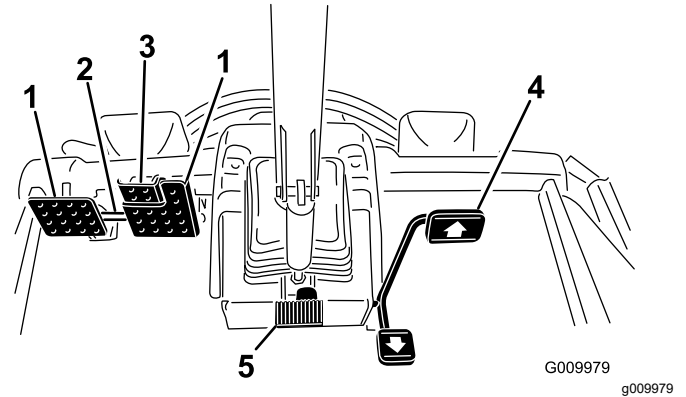

Figure 9

- |                        |                        |
|------------------------|------------------------|
| 1. Brake pedal         | 4. Traction pedal      |
| 2. Pedal-locking latch | 5. Tilt-steering pedal |
| 3. Parking-brake pedal |                        |

### Traction Pedal

The traction pedal ([Figure 9](#)) controls forward and reverse operation. Press the top of the pedal to move forward and the bottom to move backward.

To stop the machine, use 1 of the following procedures:

- Reduce your foot pressure on the traction pedal and allow it to return to the center position. The machine dynamically brakes to a smooth stop.
- Tap or hold the reverse pedal briefly. This stops the machine faster than dynamic braking.

**Note:** In emergency braking situations, press the service brake pedals in addition to using the reverse pedal as stated above. This is the quickest way to stop the machine.

### Brake Pedals

There are 2 foot pedals that operate individual wheel brakes for turning assistance, parking, and to aid in better side-hill traction. A latch connects the pedals for parking-brake operation and transport ([Figure 9](#)).

### Pedal-Locking Latch

The pedal-locking latch connects the pedals together to engage the parking brake ([Figure 9](#)).

### Parking-Brake Pedal

To engage the parking brake, ([Figure 9](#)) connect the pedals together with the pedal-locking latch and push

down on the right brake pedal while engaging the toe pedal. To release the parking brake, press 1 of the brake pedals until the parking brake latch retracts.

## Tilt-Steering Pedal

Press the tilt-steering pedal to tilt the steering wheel to the desired position, then release the pedal to lock the adjustment (Figure 9).

## Key Switch

The key switch (Figure 10) has 3 positions: OFF, ON/PREHEAT, and START.

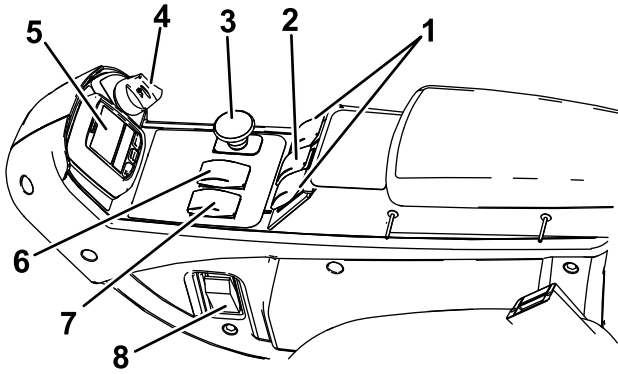
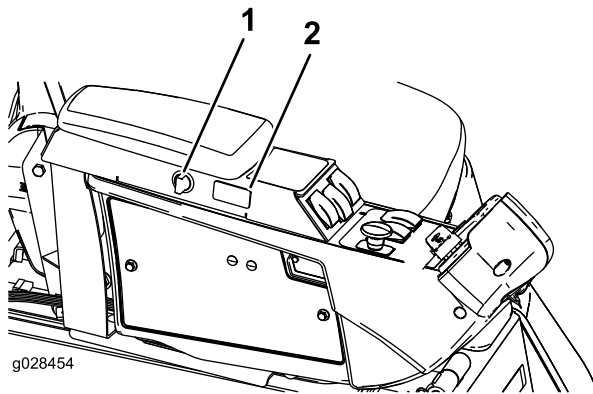

Figure 10

g208967

- |  |                        |
|--|------------------------|
| 1. Lift switches<br>(Groundsmaster 4700<br>machine only) | 5. InfoCenter          |
| 2. Lift switch (Groundsmaster<br>4500 and 4700 machines) | 6. Hi-Lo speed control |
| 3. PTO switch  | 7. Engine-speed switch |
| 4. Key switch  | 8. Light switch        |



g028454

Figure 11

g028454

- |                       |                          |
|-----------------------|--------------------------|
| 1. Power-point switch | 2. Cruise-control switch |
|-----------------------|--------------------------|

## Engine-Speed Switch

The engine-speed switch (Figure 10) has 2 modes to change the engine speed. Tap the switch to increase

or decrease the engine speed in 100 rpm increments. Hold down the switch to automatically move to High or Low idle, depending on which end of the switch you press.

## PTO Switch

The PTO switch has 2 positions: OUT (START) and IN (STOP). Pull the PTO button out to engage the cutting-unit blades. Push the button in to disengage the cutting-unit blades (Figure 10).

## High-Low Speed Control

The switch (Figure 10) allows the speed range to increase for transporting the machine. To switch between the High and Low speed ranges, raise the decks, disengage the PTO and the cruise control, put the traction pedal into the NEUTRAL position, and move the machine at a slow speed.

**Note:** The cutting decks do not operate and/or cannot be lowered from the transport position when the switch is in the high range.

## Lift Switches

The lift switches raise and lower the mower decks (Figure 10). Press the switches forward to lower the mower decks and rearward to raise the mower decks. When starting the machine, with the mower decks in the down position, press the lift switch down to allow the mower decks to float and mow.

**Note:** The decks do not lower while in the high-speed range and they do not raise or lower if you are out of the seat while the engine is running. Also, the decks lower with the key in the ON position and you are in the seat.

## Cruise-Control Switch

The cruise-control switch locks in the pedal position to maintain the desired ground speed (Figure 10). Pressing the rear of the switch turns off the cruise control, the middle position of the switch enables the cruise-control function, and the front of the switch sets the desired ground speed.

**Note:** Pressing either brake pedal or moving the traction pedal into the reverse position, for 1 second, also disengages the pedal position.

## Light Switch

Press the lower edge of the switch (Figure 10) to turn on the lights. Press the upper edge of the switch to turn off the lights.

## Power Point

Use the power point (Figure 12) to power optional 12 V electrical accessories.

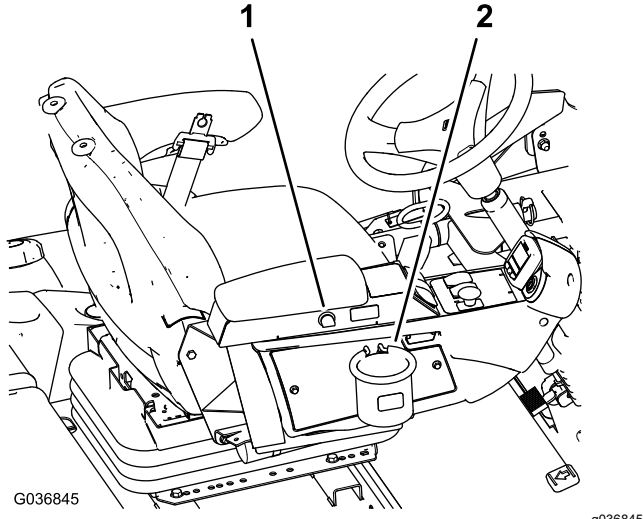

Figure 12

1. Power point
2. Bag holder

## Bag Holder

Use the bag holder for storage (Figure 12).

## Seat Adjustments

### Seat-Adjustment Lever

Move the seat adjustment lever on the side of the seat outward, slide the seat to the desired position, and release the lever to lock the seat into position (Figure 13).

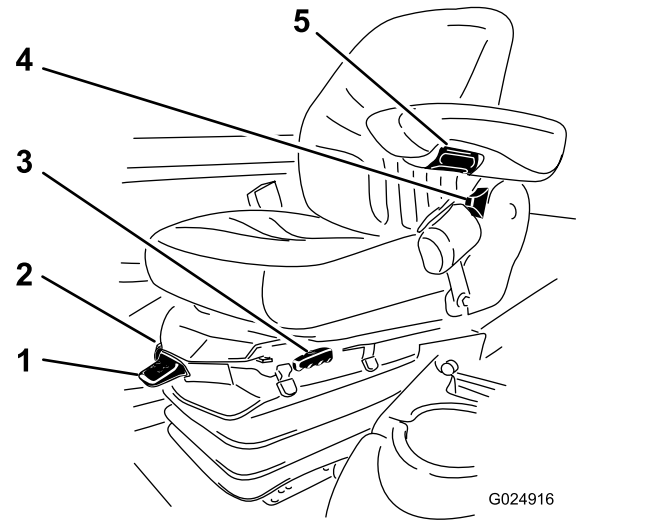

Figure 13

1. Weight gauge
2. Weight adjustment lever
3. Seat adjustment lever
4. Seat-back adjustment lever
5. Armrest adjustment knob

### Armrest Adjustment Knob

Rotate the knob to adjust the armrest angle (Figure 13).

### Seat-Back Adjustment Lever

Move the lever to adjust the seat-back angle (Figure 13).

### Weight Gauge

The weight gauge indicates when the seat is adjusted to the weight of the operator (Figure 13). Adjust the height by positioning the suspension within the range of the green region.

### Weight Adjustment Lever

Use this lever to adjust the seat to your weight (Figure 13). Pull the lever up to increase the air pressure and push the lever down to decrease the air pressure. The proper adjustment is correct when the weight gauge is in the green region.



# Using the InfoCenter LCD Display

The InfoCenter LCD display shows information about your machine, such as the operating status, various diagnostics and other information about the machine (Figure 14). There is a splash screen and main information screen of the InfoCenter. You can switch between the splash screen and main information screen at any time by pressing any of the InfoCenter buttons and then selecting the appropriate directional arrow.

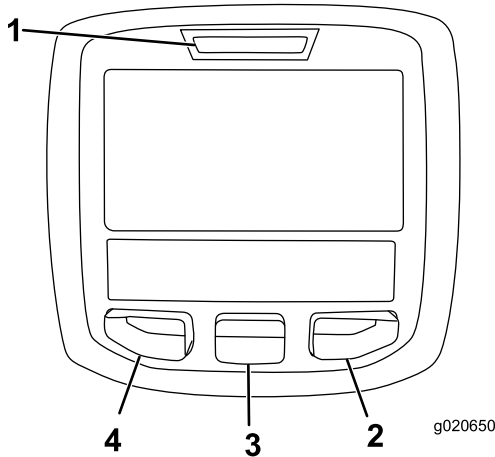

Figure 14

- 1. Indicator light
- 2. Right button
- 3. Middle button
- 4. Left button













- Left Button, Menu Access/Back Button—press this button to access the InfoCenter menus. You can use it to exit any menu that you are currently using.
- Middle Button—use this button to scroll down menus.
- Right Button—use this button to open a menu where a right arrow indicates additional content.
- Beeper—activated when lowering the cutting units or for advisories and faults.

**Note:** The purpose of each button may change depending on what is required at the time. Each button is labeled with an icon displaying its current function.













## InfoCenter Icon Description

<b>SERVICE DUE</b>	Indicates when scheduled service should be performed
	Hours remaining until service
	Reset the service hours
	The status of the engine rpm
	Info icon
	Maximum traction speed setting
	Fast
	Slow
	The fan is reversed
	Stationary regeneration is required
	The air-intake heater is active
	Raise the left cutting unit.
	Raise the center cutting unit
	Raise the right cutting unit
	The operator must sit in the seat
	The parking brake is engaged
<b>H</b>	The range is high
<b>N</b>	Neutral
<b>L</b>	Identifies the range as Low
	Coolant temperature (°C or °F)
	Temperature (hot)
	Traction or Traction Pedal
	Not allowed

## InfoCenter Icon Description (cont'd.)

	Start the engine.
	The PTO is on.
	The cruise control is on.
	Shut off the engine
	Engine
	Key switch
	Cutting units are lowering
	Cutting units are raising
<b>PIN</b>	PIN code
	Hydraulic fluid temperature
<b>CAN</b>	CAN bus
	InfoCenter
<b>Bad</b>	Bad or failed
<b>Ctr</b>	Center
<b>Rht</b>	Right
<b>Left</b>	Left
	Bulb
<b>OUT</b>	Output of TEC controller or control wire in harness
<b>HI</b>	Over the allowed range
<b>LO</b>	Under the allowed range
<b>HI / LO</b>	Out of range
	Switch
	Operator must release switch

## InfoCenter Icon Description (cont'd.)

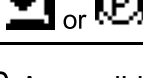
	Operator should change to indicated state
Symbols are often combined to form sentences. Some examples are shown below	
	Operator should put machine in neutral
	Engine start is denied
	Engine shutdown
	Engine coolant is too hot
	Hydraulic fluid is too hot
	DPF ash accumulation notification. Refer to Servicing the Diesel Particulate Filter (DPF) in the maintenance section for details 48.1g/l
	Reset-standby regeneration request
	Parked or recovery regeneration request
	A parked or recovery regeneration is processing.
	High exhaust temperature
	The power take-off is disabled.
	Sit down or engage parking brake

 Accessible only by entering PIN







# Using the Menus

To access the InfoCenter menu system, press the menu access button while at the main screen. This brings you to the main menu. Refer to the following tables for an overview of the options available from the menus:

Main Menu—Menu Item	Description
Faults	Contains a list of the recent machine faults; refer to the <i>Service Manual</i> for more information.
Service	Contains information on the machine such as hours of use and other similar numbers
Diagnostics	Lists various states that the machine currently has; you can use this to troubleshoot certain issues as it quickly tells you which machine controls are on and which are off.
Settings	Allows you to customize and modify configuration variables on the InfoCenter display
About	Lists the model number, serial number, and software version of your machine

Service—Menu Item	Description
Hours	Lists the total number of hours that the machine, engine, and fan have been on, as well as the number of hours the machine has been transported and overheated
Counts	Lists the number of starts, cutting unit/PTO cycles, and fan reversals the machine has experienced
DPF Regeneration	The diesel particulate filter regeneration option and DPF submenus
Inhibit Regen	Use to control reset regeneration
Parked Regen	Use to initiate a parked regeneration
Last Regen	Lists the number hours since the last reset, parked, or recovery regeneration
Recover Regen	Use to initiate a recovery regeneration

Diagnostics—Menu Item	Description
Left Cutting Unit	Refer to the <i>Service Manual</i> or your authorized Toro distributor for more information on the Engine Run menu and the information contained there.
Center Cutting Unit	
Right Cutting Unit	
Traction	
HI/LO Range	
PTO	
Engine	
Cruise	

Settings—Menu Item	Description
Units	Controls the units used on the InfoCenter (English or Metric)
Language	Controls the language used on the InfoCenter*
LCD Backlight	Controls the brightness of the LCD display
LCD Contrast	Controls the contrast of the LCD display
Protected Menus	Allows a person authorized by your company with the PIN code to access protected menus.
Protect Settings	Allows the ability to change the settings in the protected settings
Auto Idle 	Controls the amount of time allowed before idling the engine when the machine is not in use
Mow Speed 	Controls the maximum speed while in mow (low range)
Trans. Speed 	Controls the maximum speed while in transport (high range)
Smart Power 	Turns Smart Power on and off
Counterbalance 	Controls the amount of counterbalance applied by the cutting units
Turnaround 	Turns Turnaround on and off

\*Only "operator-faced" text is translated. Faults, Service, and Diagnostics screens are "service-faced." Titles are in the selected language, but menu items are in English.

 Protected under Protected Menus—accessible only by entering PIN

About—Menu Item	Description
Model	Lists the model number of the machine
SN	Lists the serial number of the machine
S/W Rev	Lists the software revision of the master controller

## Protected Menu

There are 6 operating configuration settings that are adjustable within the Settings Menu of the InfoCenter: auto idle, maximum mowing ground speed, maximum transport ground speed, Smart Power, cutting unit counterbalance, and Turnaround. These settings are in the Protected Menu.

### Accessing Protected Menus

**Note:** The factory default PIN code for your machine is either 0000 or 1234.

If you changed the PIN code and forgot the code, contact your Authorized Toro Distributor for assistance.

1. From the MAIN MENU, use the center button to scroll down to the SETTINGS MENU and press the right button (Figure 15).

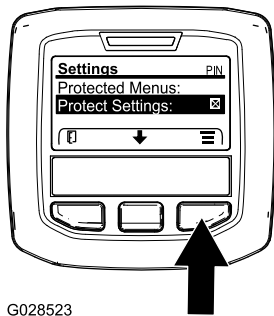

G028523

g028523

Figure 15

2. In the SETTINGS MENU, use the center button to scroll down to the PROTECTED MENU and press the right button (Figure 16A).

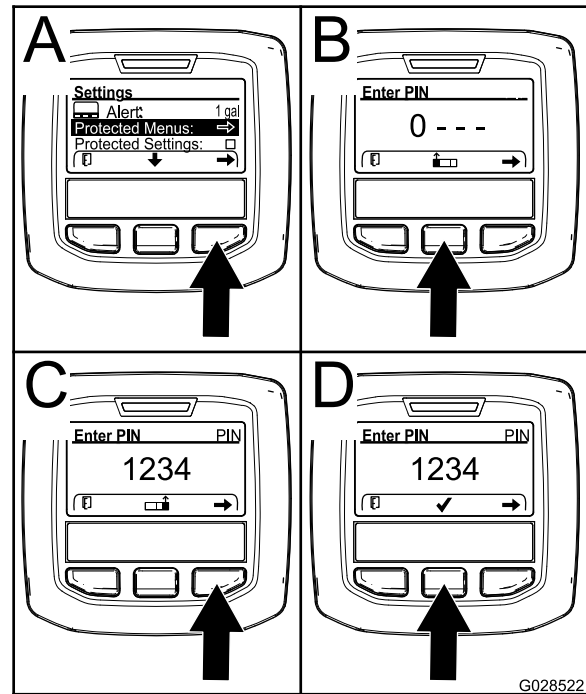

G028522

g028522

Figure 16

3. To enter the PIN code, press the center button until the correct first digit appears, then press the right button to move on to the next digit (Figure 16B and Figure 16C). Repeat this step until the last digit is entered and press the right button once more.
4. Press the middle button to enter the PIN code (Figure 16D).

Wait until the red indicator light of the InfoCenter illuminates.

**Note:** If the InfoCenter accepts the PIN code and the protected menu is unlocked, the word "PIN" displays in the upper right corner of the screen.

**Note:** Rotate the key switch to the OFF position and then to the ON position locks the protected menu.

You have the ability to view and change the settings in the Protected Menu. Once you access the Protected Menu, scroll down to Protect Settings option. Use the right button to change the setting. Setting the Protect Settings to OFF allows you to view and change the settings in the Protected Menu without entering the PIN code. Setting the Protect Settings to ON hides the protected options and requires you to enter the PIN code to change the setting in the Protected Menu. After you set the PIN code, rotate the key switch OFF and back to the ON position to enable and save this feature.

### **Viewing and Changing the Protected Menu Settings**

1. In the Protected Menu, scroll down to Protect Settings.
2. To view and change the settings without entering a PIN code, use the right button to change the Protect Settings to OFF.
3. To view and change the settings with a PIN code, use the left button to select ON, set the PIN code, and turn the key to the OFF position and then to the ON position.

### **Setting the Auto Idle**

1. In the Settings Menu, scroll down to Auto Idle.
2. Press the right button to change the auto idle time between Off, 8S, 10S, 15S, 20S, and 30S.

### **Setting the Maximum Allowed Mow Speed**

1. In the Settings Menu, scroll down to Mow Speed and press the right button.
2. Use the right button to increase the maximum mow speed in 5% increments between 50% and 100%.
3. Use the center button to decrease the maximum mow speed in 5% increments between 50% and 100%.
4. Press the left button to exit.

### **Setting the Maximum Allowed Transport Speed**

1. In the Settings Menu, scroll down to Transport Speed and press the right button.
2. Use the right button to increase the maximum transport speed in 5% increments between 50% and 100%.
3. Use the center button to decrease the maximum transport speed in 5% increments between 50% and 100%.
4. Press the left button to exit.

### **Turning the Smart Power ON/OFF**

1. In the settings menu, scroll down to Smart Power.
2. Press the right button to switch between ON and OFF.
3. Press the left button to exit.

### **Setting the Counterbalance**

1. In the Settings Menu, scroll down to Counter Balance and press the right button.
2. Press the right button to switch between Low, Med, and High.

When finished with the Protected Menu, press the left button to exit to the Main Menu, then press the left button to exit to the Run Menu.

### **Actuating Turnaround ON/OFF**

1. In the Settings Menu, scroll down to Turnaround.
2. Press the right button to switch between ON and OFF.
3. Press the left button to exit.

### **Viewing the Fuel Consumption Rate**

You can view the average fuel consumption rate for the lifetime of the machine in the Service Menu.

# Specifications

4500 Series ■  
4700 Series ■+■

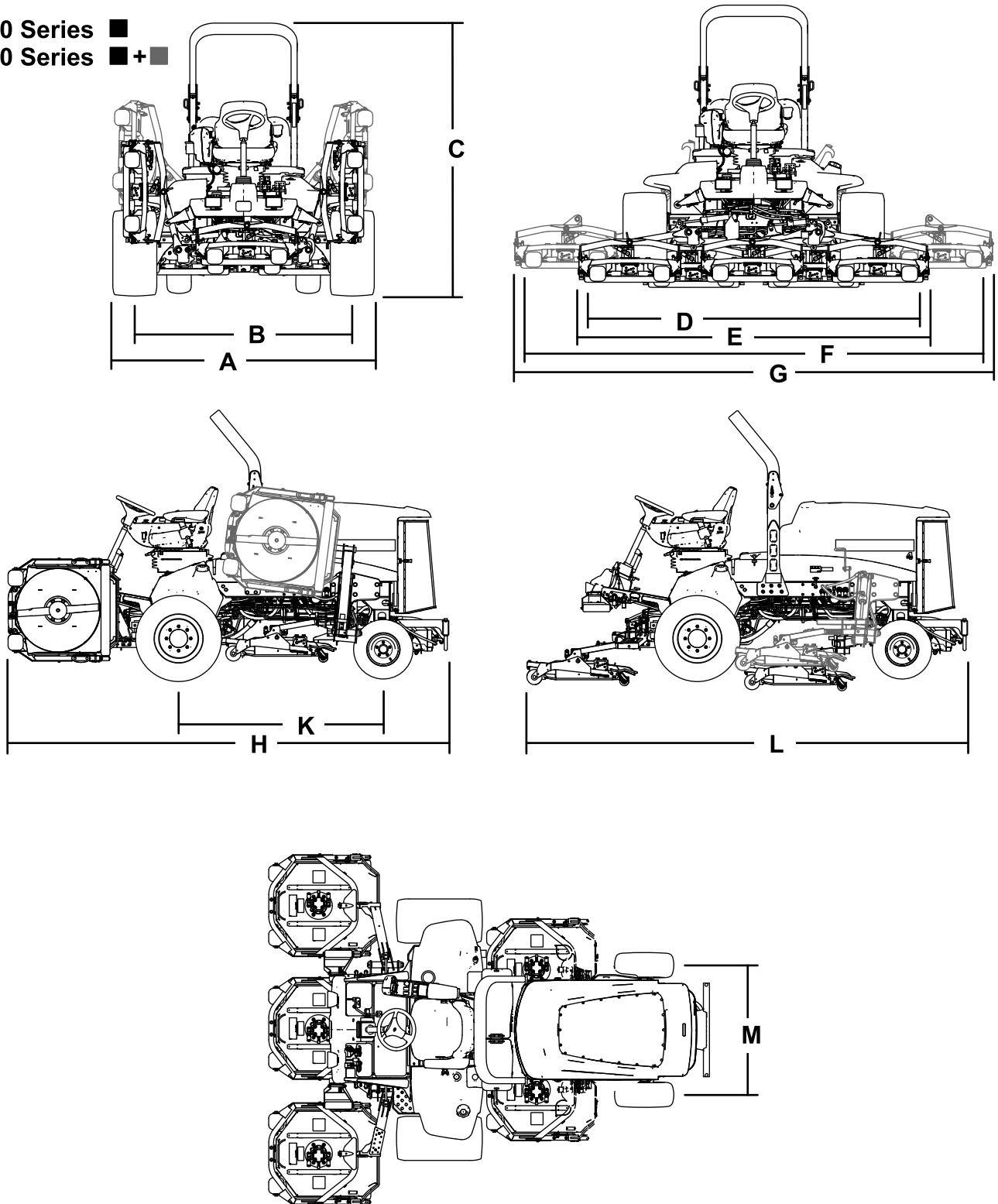

Figure 17

g198614

# Machine Specifications

## Specifications Table

Description	4500-D	Figure 17 reference	4700-D	Figure 17 reference
Width of cut	280 cm (110 inches)	D	380 cm (150 inches)	F
<b>Overall width</b>				
Cutting units down	286 cm (113 inches)	E	391 cm (154 inches)	G
Cutting units up (transport)	224 cm (88 inches)	A	224 cm (88 inches)	A
<b>Track width</b>				
Front	224 cm (88 inches)	B	224 cm (88 inches)	B
Rear	141 cm (56 inches)	M	141 cm (56 inches)	M
<b>Height with ROPS</b>	226 cm (88.8 inches)	C	226 cm (88.8 inches)	C
<b>Overall length</b>				
Cutting units down	370 cm (146 inches)	H	370 cm (146 inches)	H
Cutting units up (transport)	370 cm (146 inches)	L	370 cm (146 inches)	L
<b>Ground clearance</b>	15 cm (6 inches)		15 cm (6 inches)	
<b>Wheel base</b>	171 cm (68 inches)	K	171 cm (68 inches)	K
<b>Net weight</b> (with cutting units and no fuel)	1937 kg (4,270 lb)		2277 kg (5,020 lb)	

**Note:** Specifications and design are subject to change without notice.

## Cutting Unit Specifications

### Specifications Table

Length	86.4 cm (34 inches)
Width	86.4 cm (34 inches)
Height	24.4 cm (9.6 inches) to carrier mount 26.7 cm (10-1/2 inches) at 3/4-inch height of cut 34.9 cm (13-3/4 inches) at 4-inch height of cut
Weight	88 kg (195 lb)

## Attachments/Accessories

A selection of Toro approved attachments and accessories is available for use with the machine to enhance and expand its capabilities. Contact your Authorized Service Dealer or authorized Toro distributor or go to [www.Toro.com](http://www.Toro.com) for a list of all approved attachments and accessories.

To ensure optimum performance and continued safety certification of the machine, use only genuine Toro replacement parts and accessories. Replacement parts and accessories made by other manufacturers could be dangerous, and such use could void the product warranty.

# Operation

**Note:** Determine the left and right sides of the machine from the normal operating position.

## *Before Operation*

### Before Operation Safety

#### General Safety

- Never allow children or untrained people to operate or service the machine. Local regulations may restrict the age of the operator. The owner is responsible for training all operators and mechanics.
- Become familiar with the safe operation of the equipment, operator controls, and safety signs.
- Know how to stop the machine and shut off the engine quickly.
- Check that operator-presence controls, safety switches, and shields are attached and functioning properly. Do not operate the machine unless they are functioning properly.
- Before mowing, always inspect the machine to ensure that the blades, blade bolts, and cutting assemblies are in good working condition. Replace worn or damaged blades and bolts in sets to preserve balance.
- Inspect the area where you will use the machine and remove all objects that the machine could throw.

#### Fuel Safety

- Use extreme care in handling fuel. It is flammable and its vapors are explosive.
- Extinguish all cigarettes, cigars, pipes, and other sources of ignition.
- Use only an approved fuel container.
- Never remove the fuel cap or fill the fuel tank while the engine is running or hot.
- Never refuel the machine in an enclosed space.
- Never store the machine or fuel container where there is an open flame, spark, or pilot light, such as on a water heater or other appliance.
- If you spill fuel, do not attempt to start the engine; avoid creating any source of ignition until the fuel vapors have dissipated.

## Checking the Engine-Oil Level

Before you start the engine and use the machine, check the oil level in the engine crankcase; refer to [Checking the Engine-Oil Level \(page 58\)](#).

## Checking the Cooling System

Before you start the engine and use the machine, check the cooling system; refer to [Checking the Cooling System \(page 24\)](#).

## Checking the Hydraulic System

Before you start the engine and use the machine, check the hydraulic system; refer to [Checking the Hydraulic-Fluid Level \(page 73\)](#).

## Draining the Water Separator

Drain water or other contaminants from the water separator; refer to [Draining Water from the Fuel/Water Separator \(page 60\)](#).

## Checking the Rear Axle and Gearbox for Leaks

Check the rear axle and rear-axle gearbox for leaks; refer to [Checking the Rear Axle and Gearbox for Leaks \(page 67\)](#).



# Filling the Fuel Tank

## Fuel Tank Capacity

Fuel tank capacity: 83 L (22 US gallons)

## Fuel Specification

**Important:** Use only ultra-low sulphur diesel fuel. Fuel with higher rates of sulfur degrades the diesel oxidation catalyst (DOC), which causes operational problems and shortens the service life of engine components.

Failure to observe the following cautions may damage the engine.

- Never use kerosene or gasoline instead of diesel fuel.
- Never mix kerosene or used engine oil with the diesel fuel.
- Never keep fuel in containers with zinc plating on the inside.
- Do not use fuel additives.

## Petroleum Diesel

Cetane rating: 45 or higher

Sulfur content: Ultra-low sulfur (<15 ppm)

## Fuel Table

Diesel fuel specification	Location
ASTM D975 No. 1-D S15 No. 2-D S15	USA
EN 590	European Union
ISO 8217 DMX	International
JIS K2204 Grade No. 2	Japan
KSM-2610	Korea

- Use only clean, fresh diesel fuel or biodiesel fuels.
- Purchase fuel in quantities that can be used within 180 days to ensure fuel freshness.

Use summer-grade diesel fuel (No. 2-D) at temperatures above -7°C (20°F) and winter-grade fuel (No. 1-D or No. 1-D/2-D blend) below that temperature.

**Note:** Use of winter-grade fuel at lower temperatures provides lower flash point and cold flow characteristics which eases starting and reduces fuel filter plugging.

Using summer-grade fuel above -7°C (20°F) contributes toward longer fuel pump life and increased power compared to winter-grade fuel.

## Biodiesel

This machine can also use a biodiesel blended fuel of up to B20 (20% biodiesel, 80% petroleum diesel).

**Sulfur content:** Ultra-low sulfur (<15 ppm)

**Biodiesel fuel specification:** ASTM D6751 or EN14214

**Blended fuel specification:** ASTM D975, EN590, or JIS K2204

**Important:** The petroleum diesel portion must be ultra-low sulfur.

Observe the following precautions:

- Biodiesel blends may damage painted surfaces.
- Use B5 (biodiesel content of 5%) or lesser blends in cold weather.
- Monitor seals, hoses, gaskets in contact with fuel as they may be degraded over time.
- Fuel filter plugging may be expected for a time after converting to biodiesel blends.
- Contact your Authorized Toro Distributor if you wish for more information on biodiesel.

## Adding Fuel

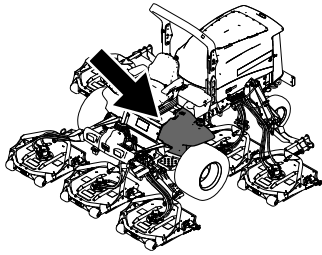

g198621

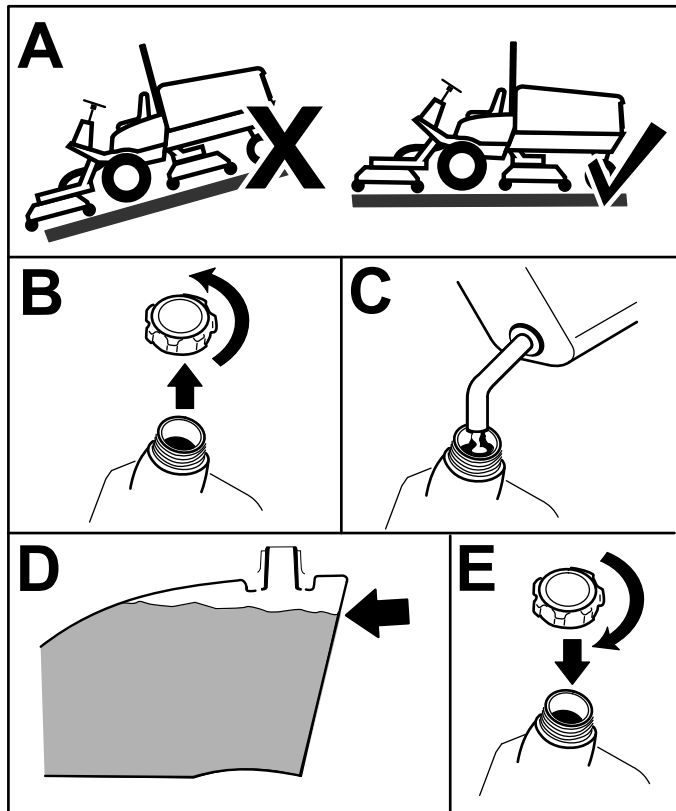

g198620

Figure 18

1. Park the machine on a level surface (Figure 18).
2. Remove the cap from the fuel tank (Figure 18).
3. Fill the tank until the level is 6 to 13 mm (1/4 to 1/2 inch) below the bottom of the filler neck (Figure 18).

**Note:** Fill the tank to about 6 to 13 mm (1/4 to 1/2 inch) below the top of the tank, not the filler neck.

4. Install the fuel-tank cap tightly after filling the tank (Figure 18).

**Note:** If possible, fill the fuel tank after each use. This minimizes possible buildup of condensation inside the fuel tank.

## Checking the Tire Pressure

**Service Interval:** Before each use or daily

The correct air pressure in the tires is 138 kPa (20 psi).

**Important:** Maintain the recommended pressure in all tires to ensure a good quality of cut and proper machine performance. Do not under-inflate the tires.

Check the air pressure in all the tires before operating the machine.

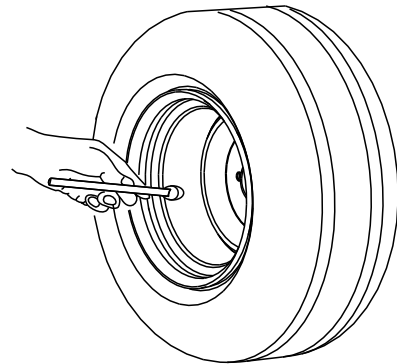

G001055

g001055

Figure 19

## Checking the Torque of the Wheel Lug Nuts

**Service Interval:** After the first hour

After the first 10 hours

Every 200 hours

Torque the wheel lug nuts to 115 to 136 N·m (85 to 100 ft-lb) in the order shown in Figure 20 and Figure 21.

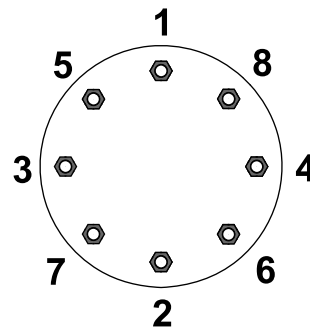

G033358

g033358

Figure 20  
Front Wheels

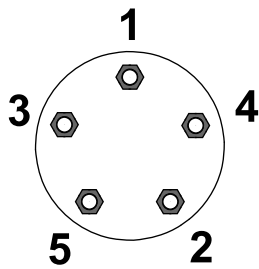

G033359

g033359

Figure 21  
Rear Wheels

### ⚠ WARNING

Failing to maintain proper torque of the wheel lug nuts could result in personal injury.

Torque the wheel lug nuts to the proper torque value.

## Adjusting the Roll Bar

### ⚠ WARNING

To avoid injury or death from rollover: keep the roll bar in the raised locked position and use the seat belt.

Ensure that the seat is secured with the seat latch.

### ⚠ WARNING

There is no rollover protection when the roll bar is in the down position.

- Do not operate the machine on uneven ground or on a hill side with the roll bar in the down position.
- Lower the roll bar only when absolutely necessary.
- Do not wear the seat belt when the roll bar is in the down position.
- Drive slowly and carefully.
- Raise the roll bar as soon as clearance permits.
- Check carefully for overhead clearances (i.e., branches, doorways, electrical wires) before driving under any objects and do not contact them.

**Important:** Always use the seat belt when the roll bar is in the raised and locked position. Do

not use the seat belt when the roll bar is in the lowered position.

## Lowering the Roll Bar

**Important:** Lower the roll bar only when necessary.

**Important:** Ensure that the seat is secured with the seat latch.

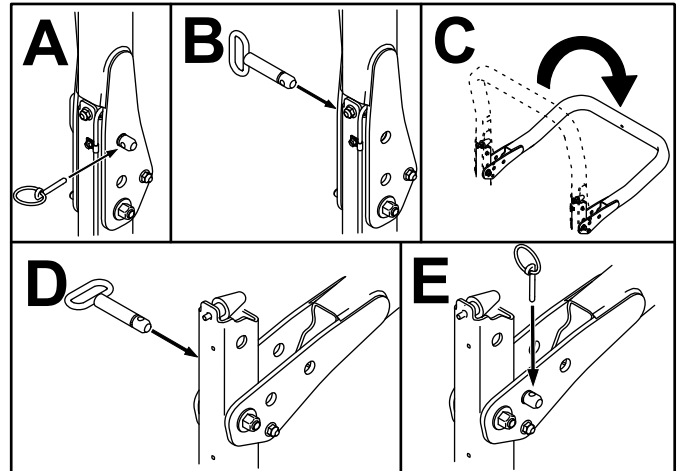

g201853

Figure 22

## Raising the Roll Bar

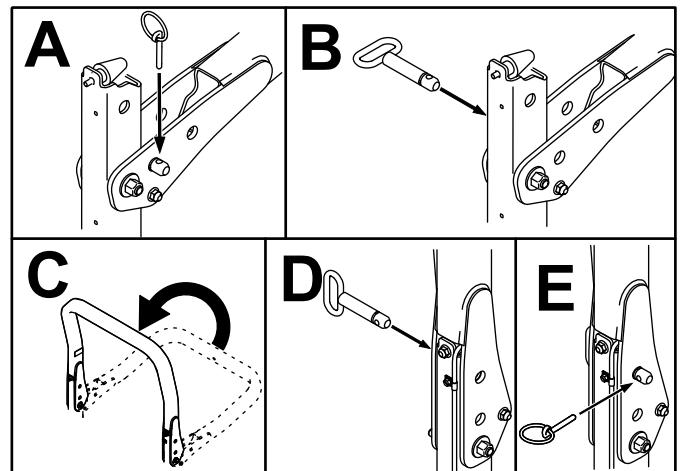

g201854

Figure 23

# Adjusting the Height of Cut

**Important:** The cutting units often cut approximately 6 mm (1/4 inch) lower than a reel cutting unit with the same bench setting. It may be necessary to set the cutting-unit bench measurement at 6 mm (1/4 inch) above that of reel cutting units cutting in the same area.

**Important:** Access to the rear cutting units is greatly improved by removing the cutting unit from the machine.

1. Park the machine on a level surface, engage the parking brake, lower the cutting unit to the ground, shut off the engine, and remove the key.
2. Loosen the bolt securing each height-of-cut bracket to the height-of-cut plate (front and each side) as shown in Figure 24.
3. Beginning with front adjustment, remove the bolt.

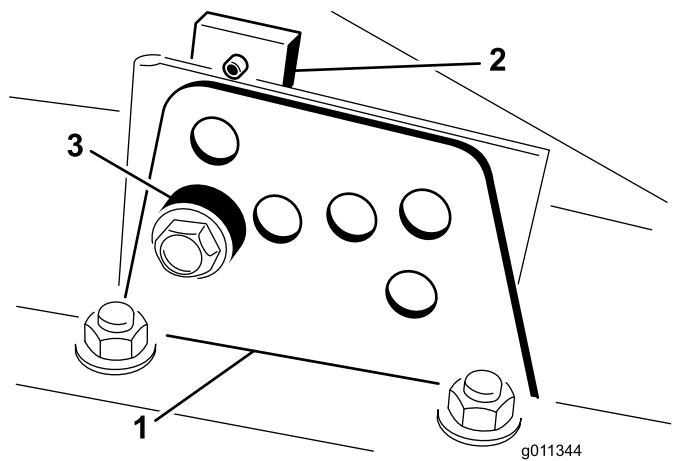

Figure 24

1. Height-of-cut bracket
2. Height-of-cut plate
3. Spacer

4. While supporting the chamber, remove the spacer (Figure 24).
5. Move the chamber to the desired height of cut and install a spacer into the designated height-of-cut hole and slot (Figure 25).

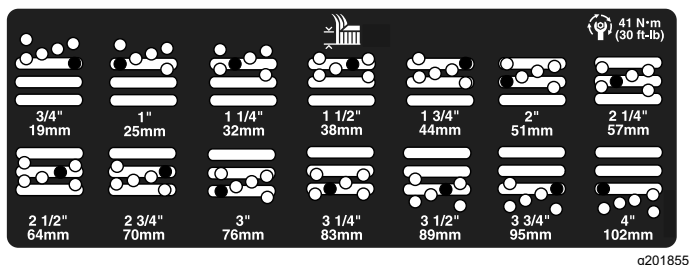

Figure 25

6. Position the tapped plate in-line with the spacer.

7. Install the bolt finger-tight.
8. Repeat steps 4 through 7 for each side adjustment.
9. Torque all 3 bolts to 41 N·m (30 ft-lb). Always tighten the front bolt first.

**Note:** Adjustments of more than 3.8 cm (1-1/2 inches) may require temporary assembly to an intermediate height to prevent binding (e.g., changing from 3.1 to 7 cm (1-1/4 to 2-3/4 inches) height of cut).

# Checking the Interlock Switches

**Service Interval:** Before each use or daily

## CAUTION

If safety interlock switches are disconnected or damaged, the machine could operate unexpectedly, causing personal injury.

- Do not tamper with the interlock switches.
- Check the operation of the interlock switches daily and replace any damaged switches before operating the machine.

The interlock switches are designed to shut off the machine when you rise from the seat when the traction pedal is pressed. However, you may rise from the seat while the engine is running and the traction pedal is in the NEUTRAL position. Although the engine continues to run when you disengage the PTO switch and release the traction pedal, shut off the engine before rising from the seat.

1. Park the machine on a level surface, engage the parking brake, lower the mower decks, and turn the key to the OFF position.
2. Press the traction pedal and turn the key to the ON position.

**Note:** If the engine cranks, there is a malfunction in the interlock system. Correct this malfunction before operating the machine.

3. Turn the key to the ON position, rise from the seat, and move the PTO switch to ON.

**Note:** The PTO should not engage. If the PTO engages, there is a malfunction in the interlock system. Correct this malfunction before operating the machine.

4. Engage the parking brake, start the engine and allow the glow plugs to heat, then turn the key to the ON position and move the traction pedal out of the NEUTRAL position.

**Note:** The InfoCenter displays "traction denied" and the machine should not move. If the machine does move, there is a malfunction in the interlock system. Correct this malfunction before operating the machine.

## Checking the Blade-Stopping Time

**Service Interval:** Before each use or daily

**Note:** Lower the cutting units onto a clean section of turf or hard surface to avoid throwing dust and debris.

To verify this stopping time, have someone stand back from the cutting units at least 6 m (20 ft) and watch the blades on 1 of the cutting units. Disengage the PTO and record the time it takes for the blades to come to a complete stop. If this time is greater than 7 seconds, adjust the braking valve. Call your authorized Toro distributor for assistance in making this adjustment.

## Selecting a Blade

### Standard Combination Sail

This blade provides excellent lift and dispersion in almost any condition. If you require more or less lift and discharge velocity, consider a different blade.

Attributes: Excellent lift and dispersion in most conditions.

### Angled Sail

This blade generally performs best in lower heights of cut—1.9 to 6.4 cm (3/4 to 2-1/2 inches).

Attributes:

- Discharge remains more even at lower heights of cut.
- Discharge has less tendency to throw left and thus leaves a cleaner look around bunkers and fairways.
- Lower power is required at lower heights and dense turf.

## High-Lift, Parallel Sail

The blade generally performs better in the higher heights of cut—7 to 10 cm (2 to 4 inches).

Attributes:

- It has more lift and a higher discharge velocity.
- Sparse or limp turf is picked up significantly at higher heights of cut.
- Wet or sticky clippings are discharged more efficiently, reducing congestion under the cutting units.
- It requires more horsepower to run.
- It tends to discharge further left and can tend to windrow at lower heights of cut.

### **⚠ DANGER**

**Using the high-lift blade with the mulching baffle could cause the blade to break, resulting in personal injury or death.**

**Do not use the high-lift blade with the baffle.**

### Atomic Blade

This blade was designed to provide excellent leaf mulching.

Attributes: Excellent leaf mulching

# Choosing Accessories

	Angle Sail Blade	High-Lift, Parallel-Sail Blade ( <i>Do not use with the mulching baffle</i> )	Mulching Baffle	Roller Scraper
Grass Cutting—1.9 to 4.4 cm (3/4 to 1-3/4 inches) height of cut	Recommended in most applications	May work well in light or sparse turf	Has been shown to improve dispersion and after cut performance on northern grasses that are cut at least 3 times per week and less than 1/3 of the grass blade is removed; <b>do not use with the high-lift, parallel-sail blade</b>	Can be used whenever the rollers build up with grass or large flat grass clumps of grass are seen; the scrapers may increase clumping in certain applications.
Grass Cutting—5 to 6.4 cm (2 to 2-1/2 inches) height of cut	Recommended for thick or lush turf	Recommended for light or sparse turf		
Grass Cutting—7 to 10 cm (2-3/4 to 4 inches) height of cut	May work well in lush turf	Recommended in most applications		
Leaf Mulching	Recommended for use with the mulching baffle	<b>Not allowed</b>	Use with combination sail or angle sail blade only	
Pros	Even discharge at lower height of cut; cleaner look around bunkers and fairways; lower power requirements	More lift and higher discharge velocity; sparse or limp turf is picked up at high height of cut; wet or sticky clippings are discharged efficiently	May improve dispersion and appearance in certain grass cutting applications; very good for leaf mulching	Reduces roller buildup in certain applications
Cons	Does not lift the grass well in high height-of-cut applications; wet or sticky grass tends to buildup in the chamber, leading to poor quality of cut and higher power requirements	Requires more power to run in some applications; tends to windrow at lower height of cut in lush grass; cannot be used with the mulching baffle	Grass will build up in the chamber if attempting to remove too much grass with baffle in place	

# *During Operation*

## During Operation Safety

### General Safety

- The owner/operator can prevent and is responsible for accidents that may cause personal injury or property damage.
- Wear appropriate clothing, including eye protection; slip-resistant, substantial foot protection; and hearing protection. Tie back long hair and do not wear jewelry.
- Do not operate the machine while ill, tired, or under the influence of alcohol or drugs.
- Never carry passengers on the machine and keep bystanders and pets away from the machine during operation.
- Operate the machine only in good visibility. Avoid holes or hidden hazards.
- Avoid mowing on wet grass. Reduced traction could cause the machine to slide.
- Before you start the engine, ensure that all drives are in neutral, the parking brake is engaged, and you are in the operating position.
- Keep your hands and feet away from the cutting units. Keep clear of the discharge opening at all times.
- Look behind and down before backing up to be sure of a clear path.
- Use care when approaching blind corners, shrubs, trees, or other objects that may obscure your vision.
- Do not mow near drop-offs, ditches, or embankments. The machine could suddenly roll over if a wheel goes over the edge or if the edge gives way.
- Stop the blades whenever you are not mowing.
- Stop the machine and inspect the blades after striking an object or if there is an abnormal vibration in the machine. Make all necessary repairs before resuming operation.
- Slow down and use caution when making turns and crossing roads and sidewalks with the machine. Always yield the right-of-way.
- Disengage the drive to the cutting unit and shut off the engine before adjusting the height of cut (unless you can adjust it from the operating position).
- Never run an engine in an area where exhaust gases are enclosed.
- Never leave a running machine unattended.

- Before leaving the operating position (including to empty the catchers or to unclog the chute), do the following:
  - Park the machine on a level surface.
  - Disengage and lower the cutting units and lower the attachments.
  - Engage the parking brake.
  - Shut off the engine and remove the key.
  - Wait for all moving parts to stop.
- Do not operate the machine when there is the risk of lightning.
- Do not change the governor speed or overspeed the engine.
- Do not use the machine as a towing vehicle.
- Use accessories and attachments approved by The Toro® Company only.

### Rollover Protection System (ROPS) Safety

- **Do not** remove the ROPS from the machine.
- Ensure that the seat belt is attached and that you can release it quickly in an emergency.
- Check carefully for overhead obstructions and do not contact them.
- Keep the ROPS in safe operating condition by thoroughly inspecting it periodically for damage and keeping all the mounting fasteners tight.
- Replace a damaged ROPS. Do not repair or alter it.

### Machines with a Foldable Roll Bar

- Always use the seat belt with the roll bar in the raised position.
- The ROPS is an integral safety device. Keep a folding roll bar in the raised and locked position, and use the seat belt when operating the machine with the roll bar in the raised position.
- Lower a folding roll bar temporarily only when necessary. Do not wear the seat belt when the roll bar is folded down.
- Be aware that there is no rollover protection when a folded roll bar is in the down position.
- Check the area that you will be mowing and never fold down a folding roll bar in areas where there are slopes, drop-offs, or water.

### Slope Safety

- Establish your own procedures and rules for operating on slopes. These procedures must

include surveying the site to determine which slopes are safe for machine operation. Always use common sense and good judgment when performing this survey.

- Slopes are a major factor related to loss-of-control and tip-over accidents, which can result in severe injury or death. Operating the machine on any slope requires extra caution.
- Operate the machine at a lower speed when you are on a slope.
- If you feel uneasy operating the machine on a slope, do not do it.
- Watch for holes, ruts, bumps, rocks, or other hidden objects. Uneven terrain could overturn the machine. Tall grass can hide obstacles.
- Choose a low ground speed so you will not have to stop or shift while on a slope.
- A rollover can occur before the tires lose traction.
- Avoid operating the machine on wet grass. Tires may lose traction; regardless if the brakes are available and functioning.
- Avoid starting, stopping, or turning the machine on a slope.
- Keep all movement on slopes slow and gradual. Do not suddenly change the speed or direction of the machine.
- Do not operate the machine near drop-offs, ditches, embankments, or bodies of water. The machine could suddenly roll over if a wheel goes over the edge or the edge caves in. Establish a safety area between the machine and any hazard (2 machine widths).

## Starting the Engine

**Important:** Bleed the fuel system if any of the following have occurred:

- The engine has shut off due to lack of fuel.
  - Maintenance has been performed upon the fuel system components.
1. Remove your foot from the traction pedal and ensure that it is in NEUTRAL. Ensure that the parking brake is engaged.
  2. Press down and hold the engine-speed switch to set the engine to low-idle speed.
  3. Turn the key to the RUN position. The glow indicator should illuminate.
  4. When the glow indicator dims, turn the key to the START position.

**Important:** Do not run the starter motor more than 15 seconds at a time or premature

starter failure may result. If the engine fails to start after 15 seconds, turn the key to the OFF position, check the controls and procedures, wait 15 additional seconds, and repeat the starting procedure.

5. Release the key immediately when the engine starts and allow it to return to the RUN position.
6. Press the engine-speed switch to set the desired engine speed.

When the temperature is less than -7°C (20°F), the starter motor can be run for 30 seconds on then 60 seconds off for 2 attempts.

**Important:** Shut off the engine and allow the engine to cool before you check for oil leaks, loose parts, or other malfunctions.

## Shutting Off the Engine

**Important:** Allow the engine to idle for 5 minutes before shutting it off after a full-load operation. This allows the turbocharger to cool down before shutting off the engine. Failure to do so may lead to turbocharger trouble.

**Note:** Lower the cutting units to the ground whenever machine is parked. This relieves the hydraulic load from the system, prevents wear on system parts and also prevents accidental lowering of the cutting units.

1. Press down and hold the engine-speed switch to set the engine to low-idle speed.
2. Move the PTO switch to the OFF position.
3. Engage the parking brake.
4. Rotate the ignition key to the OFF position.
5. Remove the key to prevent accidental starting.

## Cutting Grass with the Machine

**Note:** Cutting grass at a rate that loads the engine promotes DPF regeneration.

1. Move the machine to the job site and align the machine outside the cutting area for the first cutting pass.
2. Ensure that the PTO switch is set to the DISABLE position.
3. Move the lever for the mow-speed limiter forward.
4. Press the throttle-speed switch to set the engine speed to HIGH IDLE.
5. Use the joystick to lower the cutting units to the ground.



6. Press the PTO switch to prepare cutting units for operation.
7. Use the joystick to raise the cutting units off the ground.
8. Begin moving the machine toward the cutting area and lower the cutting units.
 

**Note:** Cutting grass at a rate that loads the engine promotes DPF regeneration.
9. When you complete the mowing pass, use the joystick to lift the cutting units.
10. Perform a tear-shaped turn to quickly line up for your next pass.

- Passive regeneration occurs continuously while the engine is running—run the engine at full engine speed when possible to promote DPF regeneration.
- If the back pressure in the DPF is too high or a reset regeneration has not occurred for 100 hours, the engine computer signals you through the InfoCenter when reset regeneration is running.
- Allow the reset regeneration process to complete before shutting off the engine.

Operate and maintain your machine with the function of the DPF in mind. Engine load at high idle (full throttle) engine speed generally produces adequate exhaust temperature for DPF regeneration.

**Important:** Minimize the amount of time that you idle the engine or operate the engine at low-engine speed to help reduce the accumulation of soot in the soot filter.

## Diesel Particulate Filter Regeneration

The diesel particulate filter (DPF) is part of the exhaust system. The diesel-oxidation catalyst of the DPF reduces harmful gasses and the soot filter removes soot from the engine exhaust.

The DPF regeneration process uses heat from the engine exhaust to incinerate the soot accumulated on the soot filter, converting the soot to ash, and clears the channels of the soot filter so that filtered engine exhaust flows out the DPF.

The engine computer monitors the accumulation of soot by measuring the back pressure in the DPF. If the back pressure is too high, soot is not incinerating in the soot filter through normal engine operation. To keep the DPF clear of soot, remember the following:

## DPF Soot Accumulation

- Over time, the diesel particulate filter accumulates soot in the soot filter. The computer for the engine monitors the soot level in the DPF.
- When enough soot accumulates, the computer informs you that it is time to regenerate the DPF.
- DPF regeneration is a process that heats the DPF to convert the soot to ash.
- In addition to the warning messages, the computer reduces the power produced by the engine at different soot-accumulation levels.

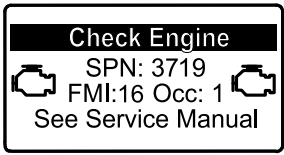
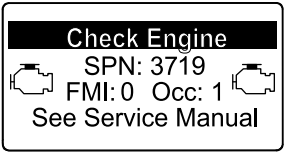

### Engine Warning Messages—Soot Accumulation

Indication Level	Fault Code	Engine Power Rating	Recommended Action
Level 1: Engine Warning	 <p style="text-align: center;"><small>g213866</small></p> <p style="text-align: center;"><b>Figure 26</b> Check Engine SPN 3719, FMI 16</p>	The computer de-rates the engine power to 85%.	Perform a parked regeneration as soon as possible; refer to <a href="#">Parked or Recovery Regeneration (page 40)</a> .
Level 2: Engine Warning	 <p style="text-align: center;"><small>g213867</small></p> <p style="text-align: center;"><b>Figure 27</b> Check Engine SPN 3719, FMI 0</p>	The computer de-rates the engine power to 50%.	Perform a recovery regeneration as soon as possible; refer to <a href="#">Parked or Recovery Regeneration (page 40)</a> .

# DPF Ash Accumulation

- The lighter ash is discharged through the exhaust system; the heavier ash collects in the soot filter.
- Ash is a residue of the regeneration process. Over time, the diesel particulate filter accumulates ash that does not discharge with the engine exhaust.
- The computer for the engine calculates the amount of ash accumulated in the DPF.
- When enough ash accumulates, the engine computer sends information to the InfoCenter in the form of an engine fault to indicate the accumulation of ash in the DPF.
- The fault messages indicate that it is time to service the DPF.
- In addition to the warnings, the computer reduces the power produced by the engine at different ash-accumulation levels.

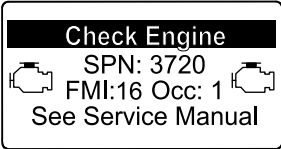
## InfoCenter Advisory and Engine Warning Messages—Ash Accumulation

Indication Level	Fault Code	Engine Speed Reduction	Engine Power Rating	Recommended Action
Level 1: Engine Warning	 <p>Check Engine SPN: 3720 FMI:16 Occ: 1 See Service Manual</p> <p><small>g213863</small></p> <p><b>Figure 28</b> Check Engine SPN 3720, FMI 16</p>	None	The computer de-rates the engine power to 85%.	Service the DPF; refer to <a href="#">Servicing the Diesel-Oxidation Catalyst (DOC) and the Soot Filter (page 59)</a>
Level 2: Engine Warning	 <p>Check Engine SPN: 3720 FMI:16 Occ: 1 See Service Manual</p> <p><small>g213863</small></p> <p><b>Figure 29</b> Check Engine SPN 3720, FMI 16</p>	None	The computer de-rates the engine power to 50%.	Service the DPF; refer to <a href="#">Servicing the Diesel-Oxidation Catalyst (DOC) and the Soot Filter (page 59)</a>
Level 3: Engine Warning	 <p>Check Engine SPN: 3251 FMI: 0 Occ: 1 See Service Manual</p> <p><small>g214715</small></p> <p><b>Figure 30</b> Check Engine SPN 3251, FMI 0</p>	Engine speed at maximum torque + 200 rpm	The computer de-rates the engine power to 50%.	Service the DPF; refer to <a href="#">Servicing the Diesel-Oxidation Catalyst (DOC) and the Soot Filter (page 59)</a>

# Types of Diesel Particulate Filter Regeneration

## Types of diesel particulate filter regeneration that are performed while the machine is operating:

Type of Regeneration	Conditions that cause DPF regeneration	DPF description of operation
<b>Passive</b>	Occurs during normal operation of the machine at high-engine speed or high-engine load	<ul style="list-style-type: none"> <li>The InfoCenter does not display an icon indicating passive regeneration.</li> <li>During passive regeneration, the DPF processes high-heat exhaust gasses, oxidizing harmful emissions, and burning soot to ash.</li> </ul> Refer to <a href="#">Passive DPF Regeneration (page 37)</a> .
<b>Assist</b>	Occurs because of low-engine speed, low-engine load, or after the computer detects the DPF is becoming obstructed with soot	<ul style="list-style-type: none"> <li>The InfoCenter does not display an icon indicating assist regeneration.</li> <li>During assist regeneration, the engine computer adjusts the engine settings to raise the exhaust temperature.</li> </ul> Refer to <a href="#">Assist DPF Regeneration (page 38)</a> .
<b>Reset</b>	Occurs every 100 hours  Also occurs after assist regeneration only if the computer detects that assist regeneration did not sufficiently reduce the soot level	 <ul style="list-style-type: none"> <li>When the high exhaust-temperature icon is displayed in the InfoCenter, a regeneration is in progress.</li> <li>During reset regeneration, the engine computer adjusts the engine settings to raise the exhaust temperature.</li> </ul> Refer to <a href="#">Reset Regeneration (page 38)</a> .

## Types of diesel particulate filter regeneration that require you to park the machine:

Type of Regeneration	Conditions that cause DPF regeneration	DPF description of operation
<b>Parked</b>	Occurs because the computer detects back pressure in the DPF due to soot buildup  Also occurs because the operator initiates a parked regeneration  May occur because you set the InfoCenter to inhibit reset regeneration and continued operating the machine, adding more soot when the DPF already needs a reset regeneration  May result from using the incorrect fuel or engine oil	<ul style="list-style-type: none"> <li>When the reset-standby/parked or recovery regeneration icon  or ADVISORY #188 displays in the InfoCenter, a regeneration is requested.</li> <li>Perform the parked regeneration as soon as possible to avoid needing a recovery regeneration.</li> <li>A parked regeneration requires 30 to 60 minutes to complete.</li> <li>You must have at least a 1/4 tank of fuel in the tank.</li> <li>You must park the machine to perform a parked regeneration.</li> </ul> Refer to <a href="#">Parked or Recovery Regeneration (page 40)</a> .

## Types of diesel particulate filter regeneration that require you to park the machine: (cont'd.)

Type of Regeneration	Conditions that cause DPF regeneration	DPF description of operation
Recovery	Occurs because the operator ignored requests for a parked regeneration and continued operating the machine, adding more soot to the DPF	<ul style="list-style-type: none"> <li>When the reset-standby/parked or recovery regeneration icon  or ADVISORY #190 displays in the InfoCenter, a recovery regeneration is requested.</li> <li>A recovery regeneration requires up to 3 hours to complete.</li> <li>You must have at least a 1/2 tank of fuel in the machine.</li> <li>You must park the machine to perform a recovery regeneration.</li> </ul> <p>Refer to <a href="#">Parked or Recovery Regeneration (page 40)</a>.</p>

## Accessing the DPF Regeneration Menus

### Accessing the DPF Regeneration Menus

1. Access the Service menu, press the center button to scroll down to the DPF REGENERATION option ([Figure 31](#)).

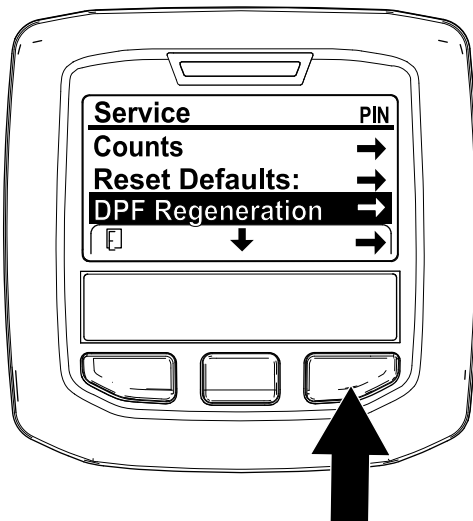

Figure 31

g227667

2. Press the right button to select the DPF Regeneration entry ([Figure 31](#)).

### Time Since Last Regeneration

Access the DPF Regeneration menu, press the center button to scroll down to the LAST REGEN field ([Figure 32](#)).

Use the LAST REGEN field to determine how many hours you have run the engine since the last reset, parked, or recovery regeneration.

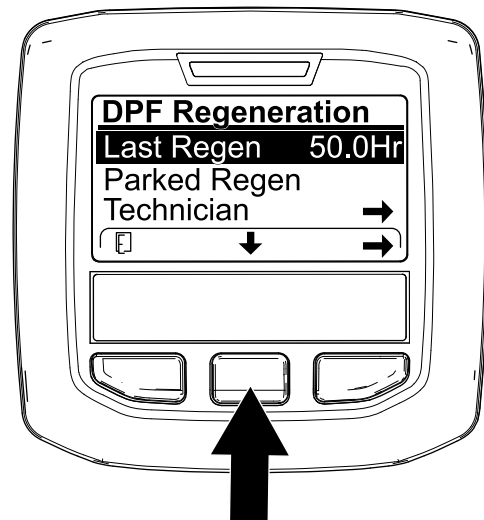

Figure 32

g224693

### Technician Menu

**Important:** For operating convenience, you may decide to perform a parked regeneration before the soot load reaches 100%, provided the engine has run more than 50 hours since the last successful reset, parked, or recovery regeneration.

Use the technician menu to view the current state of engine regeneration control and view the reported soot level.

Access the DPF Regeneration menu, press the center button to scroll down to the TECHNICIAN option, and

press the right button to select the Technician entry (Figure 33).

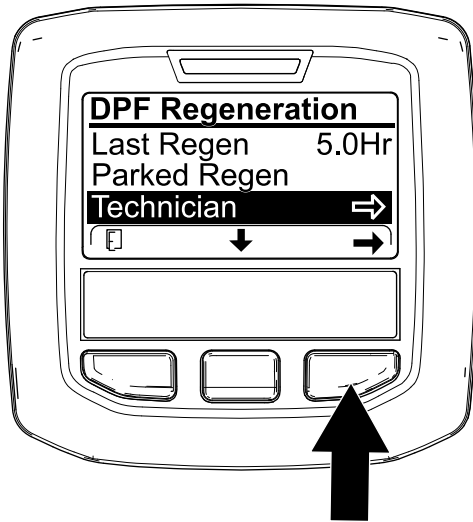

Figure 33

g227348

- Use the DPF operation table to understand the current state of DPF operation (Figure 34).

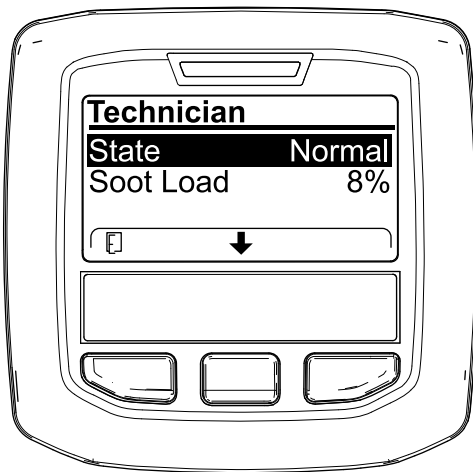

Figure 34

g227360

**DPF Operation Table**

State	Description	
Normal	The DPF is in normal-operating mode—passive regeneration.	
Assist Regen	The engine computer is performing an assist regeneration.	
Reset Stby	The engine computer is trying to run a reset regeneration, but 1 of the following conditions prevents regeneration:	The regen inhibit setting is set to ON.
		The exhaust temperature is too low for regeneration.

**DPF Operation Table (cont'd.)**

State	Description
Reset Regen	The engine computer is running a reset regeneration.
Parked Stby	The engine computer is requesting that you run a parked regeneration.
Parked Regen	You initiated a parked regeneration request and the engine computer is processing the regeneration.
Recov. Stby	The engine computer is requesting that you run a recovery regeneration.
Recov. Regen	You initiated a recovery regeneration request and the engine computer is processing the regeneration.

- View the soot load which is measured as the percentage of soot in the DPF (Figure 35); refer to the soot-load table.

**Note:** The soot load value varies as the machine is operated and DPF regeneration occurs.

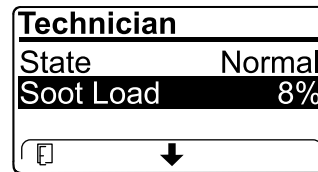

Figure 35

g227359

**Soot-Load Table**

Important Soot Load Values	Regeneration State
0% to 5%	Minimum soot load range
78%	The engine computer performs an assist regeneration.
100%	The engine computer automatically requests a parked regeneration.
122%	The engine computer automatically requests a recovery regeneration.

**Passive DPF Regeneration**

- Passive regeneration occurs as part of normal engine operation.
- While operating the machine, run the engine at full-engine speed and high load when possible to promote DPF regeneration.

## Assist DPF Regeneration

- The engine computer adjusts engine settings to raise the exhaust temperature.
- While operating the machine, run the engine at full engine speed and high load when possible to promote DPF regeneration.

## Reset Regeneration

### ⚠ CAUTION

The exhaust temperature is hot (approximately 600°C (1,112°F)) during DPF regeneration. Hot exhaust gas can harm you or other people.

- Never operate the engine in an enclosed area.
- Make sure that there are no flammable materials around the exhaust system.
- Never touch a hot exhaust system component.
- Never stand near or around the exhaust pipe of the machine.

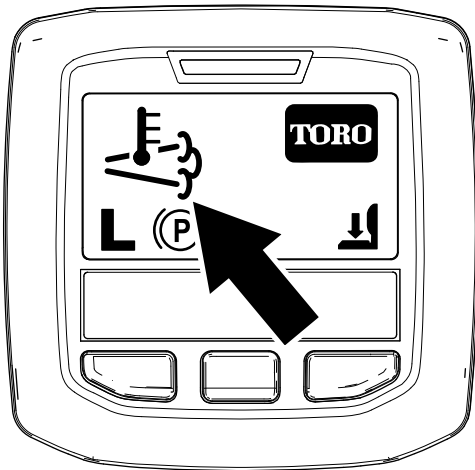



Figure 36

g224417

- The high exhaust-temperature icon  displays in the InfoCenter (Figure 36).
- The engine computer adjusts engine settings to raise the exhaust temperature.

**Important:** The high exhaust-temperature icon indicates that the exhaust temperature discharged from of your machine may be hotter than during regular operation.

- While operating the machine, run the engine at full engine speed and high load when possible to promote DPF regeneration.

- The icon displays in the InfoCenter while the reset regeneration is processing.
- Whenever possible, do not shut off the engine or reduce engine speed while the reset regeneration is processing.

**Important:** Whenever possible, allow the machine to complete the reset regeneration process before shutting off the engine.

## Periodic Reset Regeneration

If the engine has not completed a successful Reset, Parked, or Recovery regeneration in the previous 100 hours of engine operation, the engine computer will attempt to perform a reset regeneration.

## Setting the Inhibit Regen

### Reset Regeneration Only

**Note:** If you set the InfoCenter to inhibit regeneration, the InfoCenter displays ADVISORY #185 (Figure 37) every 15 minutes while the engine requests a reset regeneration.

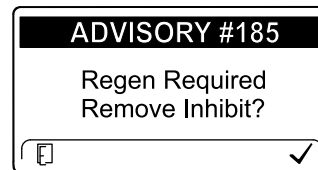

Figure 37

g224692

A reset regeneration produces the elevated engine exhaust. If you are operating the machine around trees, brush, tall grass, or other temperature-sensitive plants or materials, you can use the Inhibit Regen setting to prevent the engine computer from performing a reset regeneration.

**Important:** When you shut off the engine and start it again, the inhibit regen setting defaults to OFF.

1. Access the DPF Regeneration menu, press the center button to scroll down to the INHIBIT REGEN option, and press the right button to select the Inhibit Regen entry (Figure 38).

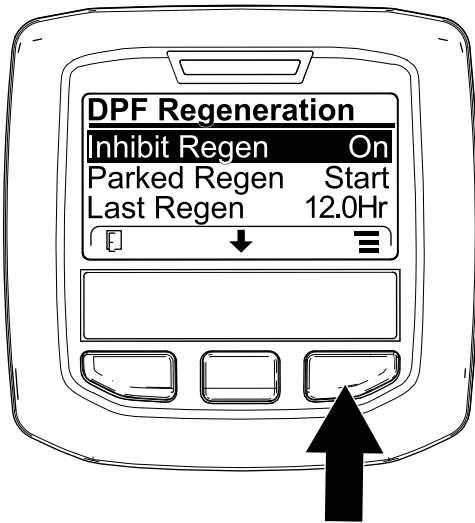

Figure 38

g227304

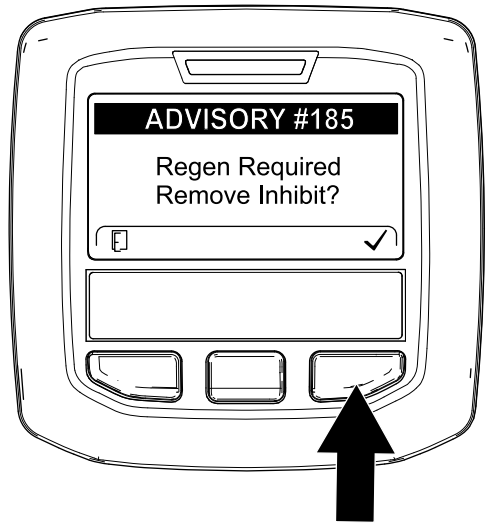

Figure 40

g224394

- Press the right button to change the inhibit regeneration setting from On to Off (Figure 38) or from Off to On (Figure 39).

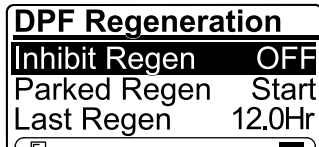

Figure 39

g224691

**Note:** If the engine exhaust temperature is too low, the InfoCenter displays ADVISORY #186 (Figure 41) to inform you to set the engine to full throttle (high idle).

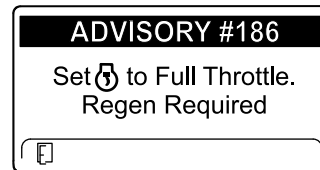



Figure 41

g224395

### Allowing a Reset Regeneration

The InfoCenter displays the high exhaust-temperature

icon  when the reset regeneration is in process.

**Note:** If INHIBIT REGEN is set to ON, the InfoCenter displays ADVISORY #185 (Figure 40). Press button 3 to set inhibit regeneration setting to OFF and continue with the reset regeneration.

**Note:** When the reset regeneration completes, the

high exhaust-temperature  disappears from the InfoCenter screen.

## Parked or Recovery Regeneration

- When the engine computer requests either a parked regeneration or a recovery regeneration, the regeneration request icon (Figure 42) displays in the InfoCenter.

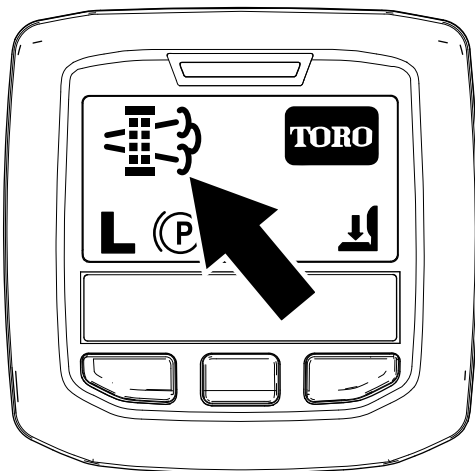

Figure 42

g224404

- The machine does not automatically perform a parked regeneration or a recovery regeneration, you must run the regeneration through the InfoCenter.

### Parked Regeneration Messages

When a parked regeneration is requested by the engine computer the following messages display in the InfoCenter:

- Engine warning SPN 3720, FMI 16 (Figure 43)

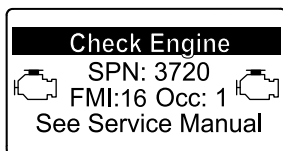

Figure 43

g213863

- Parked regeneration required ADVISORY #188 (Figure 44)

**Note:** Advisory #188 displays every 15 minutes.

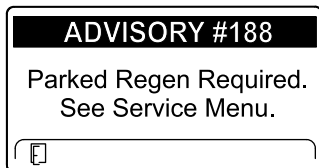

Figure 44

g224397

- If you do not perform a parked regeneration within 2 hours, the InfoCenter displays parked

regeneration required—power takeoff disabled ADVISORY #189 (Figure 45).

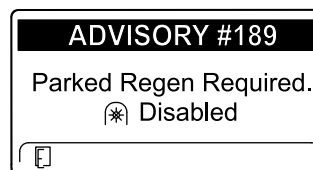

Figure 45

g224398

**Important:** Perform a parked regeneration to restore the PTO function; refer to [Preparing to Perform a Parked or Recovery Regeneration \(page 41\)](#) and [Performing a Parked or Recovery Regeneration \(page 41\)](#).

**Note:** The Home screen displays the PTO disabled Icon (Figure 46).

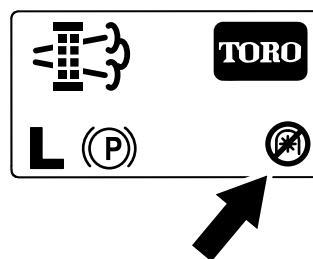

Figure 46

g224415

### Recovery Regeneration Messages

When a recovery regeneration is requested by the engine computer, the following messages display in the InfoCenter:

- Engine warning SPN 3719, FMI 0 (Figure 47)

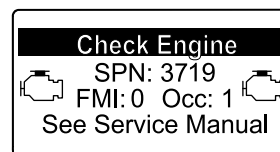

Figure 47

g213867

- Recovery regeneration required—power takeoff disabled ADVISORY #190 (Figure 48)

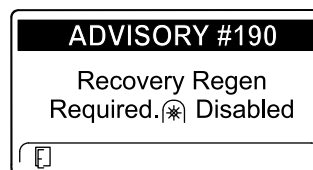

Figure 48

g224399



**Important:** Perform a recovery regeneration to restore the PTO function; refer to [Preparing to Perform a Parked or Recovery Regeneration \(page 41\)](#) and [Performing a Parked or Recovery Regeneration \(page 41\)](#).

**Note:** The Home screen displays the PTO disabled icon; refer to [Figure 46 in Parked Regeneration Messages \(page 40\)](#).

### DPF Status-Limitation

- If the engine computer requests a recovery regeneration or is processing a recovery regeneration and you scroll down to the PARKED REGEN option, parked regeneration locks and the lock icon ([Figure 49](#)) appears in the lower right corner of the InfoCenter.

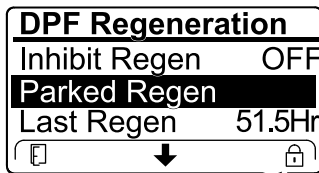

Figure 49

g224625

- If the engine computer has not requested a recovery regeneration and you scroll down to the RECOVERY REGEN option, the recovery regeneration locks and the lock icon ([Figure 50](#)) appears in the lower right corner of the InfoCenter.

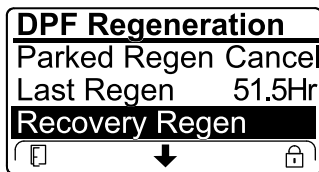

Figure 50

g224628

### Preparing to Perform a Parked or Recovery Regeneration

- Ensure that the machine has fuel in the tank for the type of regeneration you are performing:
  - Parked Regeneration:** Ensure that you have 1/4 tank of fuel before performing the parked regeneration.
  - Recovery Regeneration:** Ensure that you have 1/2 tank of fuel before performing the recovery regeneration.

- Move the machine outside to an area away from combustible materials.
- Park the machine on a level surface.
- Ensure that the traction control or motion-control levers are in the NEUTRAL position.
- If applicable, shut off the PTO, and lower the cutting units or accessories.
- Engage the parking brake.
- Set the throttle to the low IDLE position.

### Performing a Parked or Recovery Regeneration

#### ⚠ CAUTION

The exhaust temperature is hot (approximately 600°C (1,112°F) during DPF regeneration. Hot exhaust gas can harm you or other people.

- Never operate the engine in an enclosed area.
- Make sure that there are no flammable materials around the exhaust system.
- Never touch a hot exhaust system component.
- Never stand near or around the exhaust pipe of the machine.

**Important:** The computer of the machine cancels DPF regeneration if you increase the engine speed from low idle or release the parking brake.

- Access the DPF Regeneration menu, press the center button to scroll down to either the PARKED REGEN START option or the RECOVERY REGEN START option ([Figure 51](#)), and press the right button to select the start the regeneration ([Figure 51](#)).

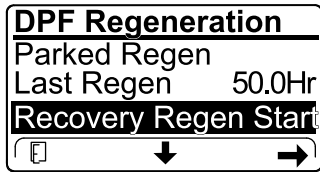
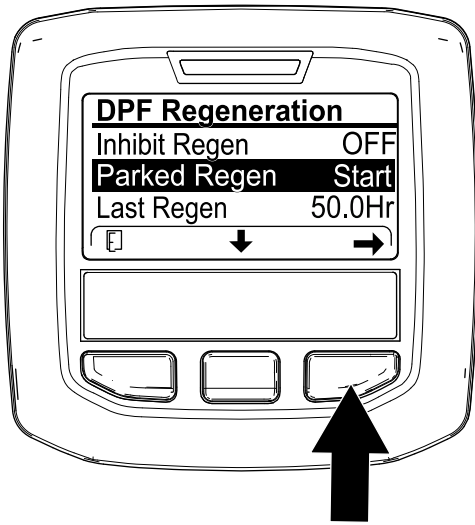

Figure 51

g224402

g224629

- At the DPF checklist screen, verify that the parking brake is engaged and that the engine speed is set to low idle (Figure 53).

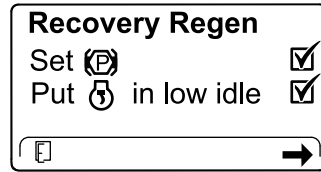
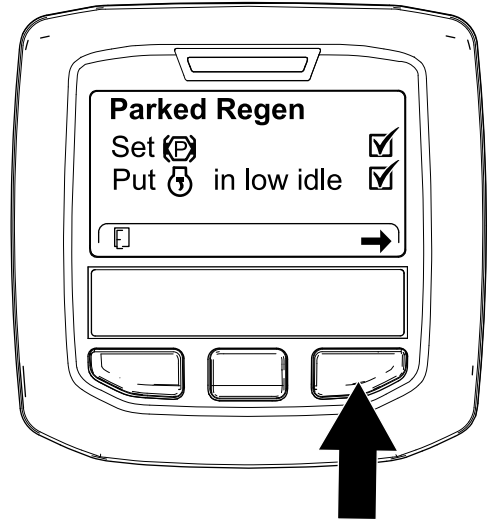

Figure 53

g224407

g227679

- At the VERIFY FUEL LEVEL screen, verify that you have 1/4 tank of fuel if you are performing the parked regeneration or 1/2 tank of fuel if you are performing the recovery regeneration, and press the right button to continue (Figure 52).

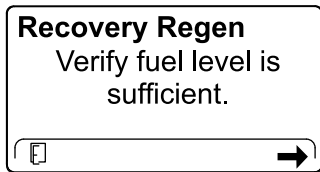
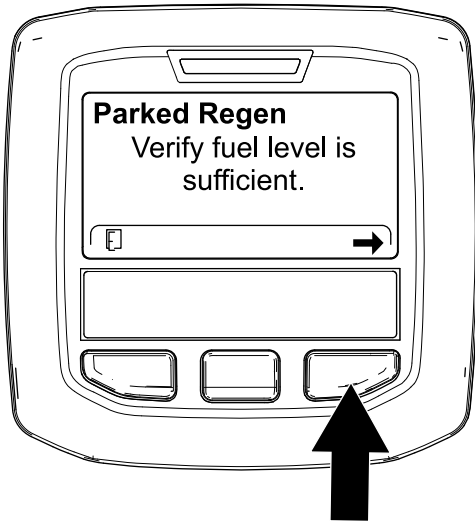

Figure 52

g224414

g227678

- At the INITIATE DPF REGEN screen, press the right button to continue (Figure 54).

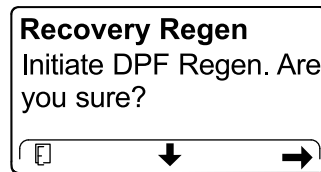
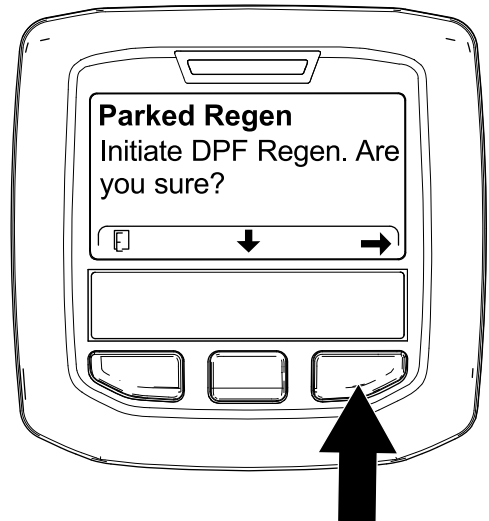
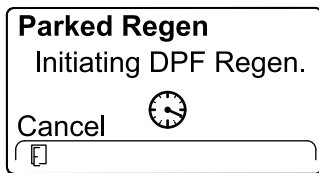

Figure 54

g224626

g224630

5. The InfoCenter displays the INITIATING DPF REGEN message (Figure 55).



g224411

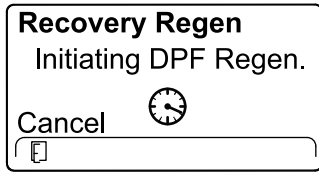

g227681

Figure 55

6. The InfoCenter displays the time to complete message (Figure 56).

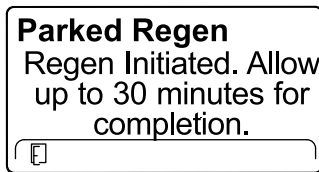

g224406

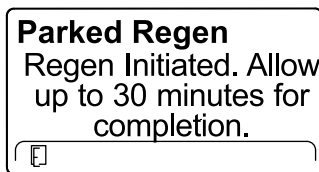

g224406

Figure 56

7. The engine computer checks the engine state and fault information. The InfoCenter may display the following messages found in the table that follows:

### Check Message and Corrective Action Table

<p><b>Corrective Action:</b> Exit the regeneration menu and run the machine until the time since last regeneration is greater than 50 hours; refer to <a href="#">Time Since Last Regeneration</a> (page 36).</p>	
<p><b>Corrective Action:</b> Troubleshoot the engine fault and retry DPF regeneration.</p>	

### Check Message and Corrective Action Table (cont'd.)

<p><b>Corrective Action:</b> Start and run the engine.</p>	
<p><b>Corrective Action:</b> Run the engine to warm the coolant temperature to 60°C (140°F).</p>	
<p><b>Corrective Action:</b> Change the engine speed to low idle.</p>	
<p><b>Corrective Action:</b> Troubleshoot the engine computer condition and retry DPF regeneration.</p>	

8. The InfoCenter displays the home screen and the regeneration acknowledge icon (Figure 57) appears in the lower right corner of the screen as the regeneration processes.

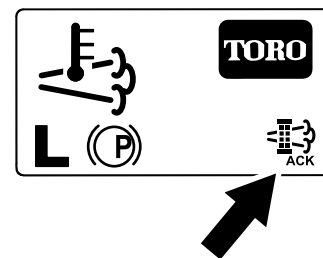

Figure 57

g224403

**Note:** While the DPF regeneration runs, the InfoCenter displays the high

exhaust-temperature icon .

9. When the engine computer completes a parked or recovery regeneration, the InfoCenter

displays ADVISORY #183 (Figure 58). Press the left button to exit to the home screen.

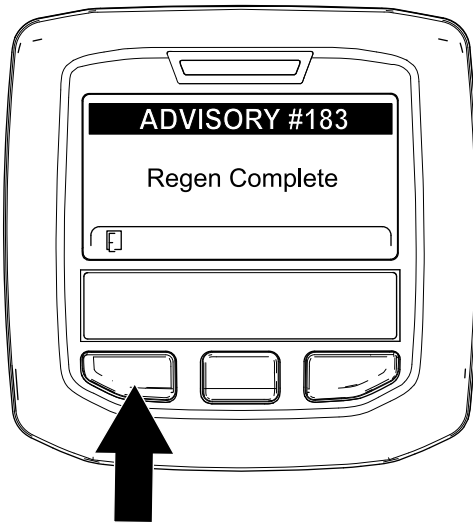

Figure 58

g224392

**Note:** If the regeneration fails to complete, the InfoCenter displays Advisory #184 (Figure 59). Press the left button to exit to the home screen.

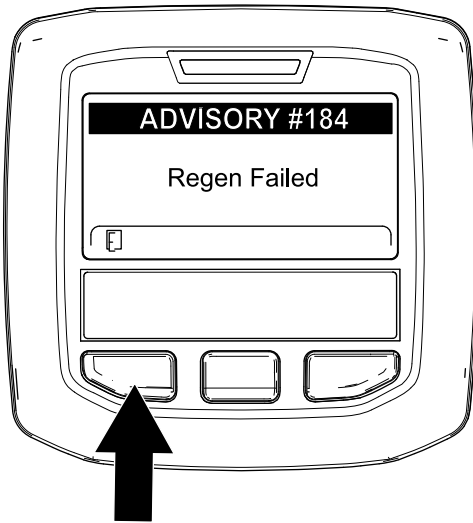

Figure 59

g224393

## Canceling a Parked or Recovery Regeneration

Use the Parked Regen Cancel or Recovery Regen Cancel setting to cancel a running parked or recovery regeneration process.

1. Access the DPF Regeneration menu (Figure 60).

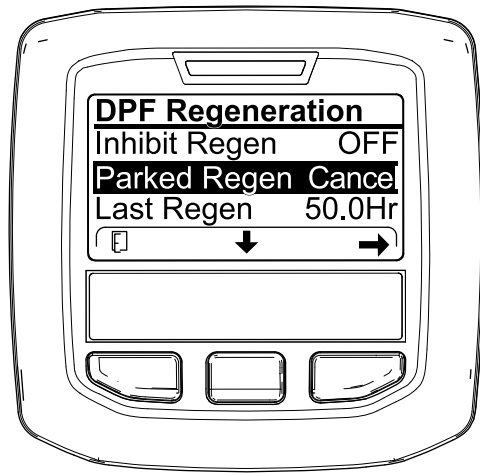

Figure 60

g227305

2. Press the center button to scroll down to the PARKED REGEN CANCEL (Figure 60) or the RECOVERY REGEN CANCEL option (Figure 61).

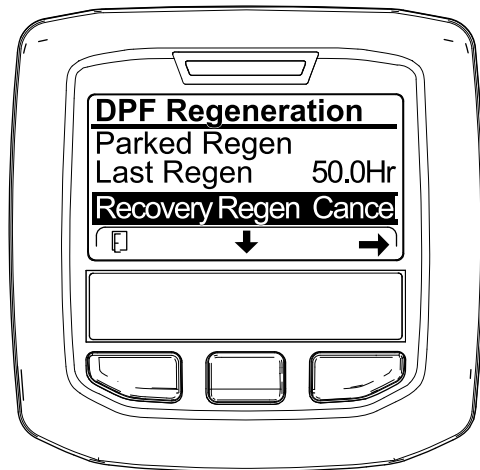

Figure 61

g227306

3. Press the right button to select the Regen Cancel entry (Figure 60 or Figure 61).

# Understanding the Operating Characteristics of the Machine

Practice driving the machine because it has a hydrostatic transmission, and its characteristics are different than many turf maintenance machines.

Smart Power prevents bogging down in heavy turf by automatically controlling the machine speed and optimizing cutting performance.

You can use the brakes to assist in turning the machine. However, use them carefully, especially on soft or wet grass because the turf may be torn accidentally. The brakes can also help you to maintain traction. For example, on some slopes, the uphill wheel can slip and lose traction. In this situation, press the uphill turn pedal gradually and intermittently until the uphill wheel stops slipping, thus increasing traction on the downhill wheel.

Use extra care when operating the machine on slopes. Make sure that the seat latch is properly secured and that the seat belt is buckled. Drive slowly and avoid sharp turns on slopes to prevent rollovers. For steering control, lower the cutting units when going downhill.

**Important:** Allow the engine to idle for 5 minutes before shutting it off after a full load operation. This allows the turbo charger to cool down before shutting the engine off. Failure to do so may damage the turbo-charger.

Before shutting off the engine, disengage all controls and set the engine speed to slow to reduce the engine speed to slow reduces high engine speed (rpm), noise, and vibration. Turn the key to the OFF position to shut off the engine.

# Operating the Engine-Cooling Fan

The engine cooling fan is normally controlled by the machine. The machine can reverse the fan to blow debris off the rear screen. Under normal operating conditions, the machine controls the fan speed and direction based on coolant and hydraulic-fluid temperature, and the fan automatically reverses direction to blow debris off the rear screen. A reverse cycle is automatically initiated when either the coolant or hydraulic-fluid temperature reaches a specific temperature.

You can manually reverse the fan by pressing the 2 outer buttons of the InfoCenter for 2 seconds—the fan completes a manually initiated reverse cycle. Reverse the fan when the rear screen is clogged or prior to moving the machine into the shop or a storage area.

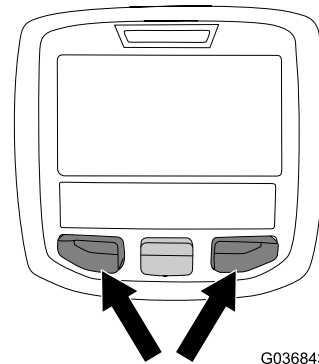

G036843

g036843

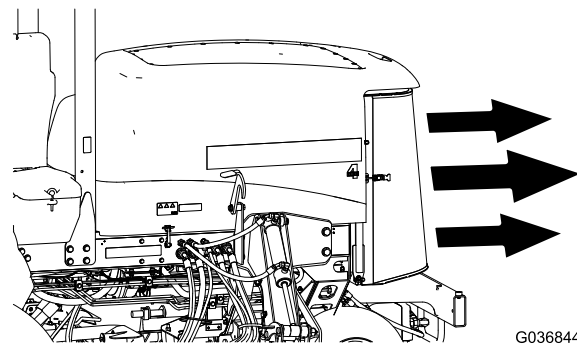

G036844

g036844

Figure 62

# Using Cruise Control

The cruise-control switch locks in the pedal position to maintain the desired ground speed. Pressing the rear of the switch turns the cruise control off, the middle position of the switch enables the cruise-control function, and the front of the switch sets the desired ground speed.

**Note:** Pressing either the brake pedal or moving the traction pedal into the REVERSE position, for 1 second, also disengages the pedal position.

# Using the Transport Latches

## Groundsmaster 4700 Only

Use the 2 rear-transport latches for the No. 6 and 7 mower decks when moving the machine over long distances, rough terrain, when transporting, or storing the machine.

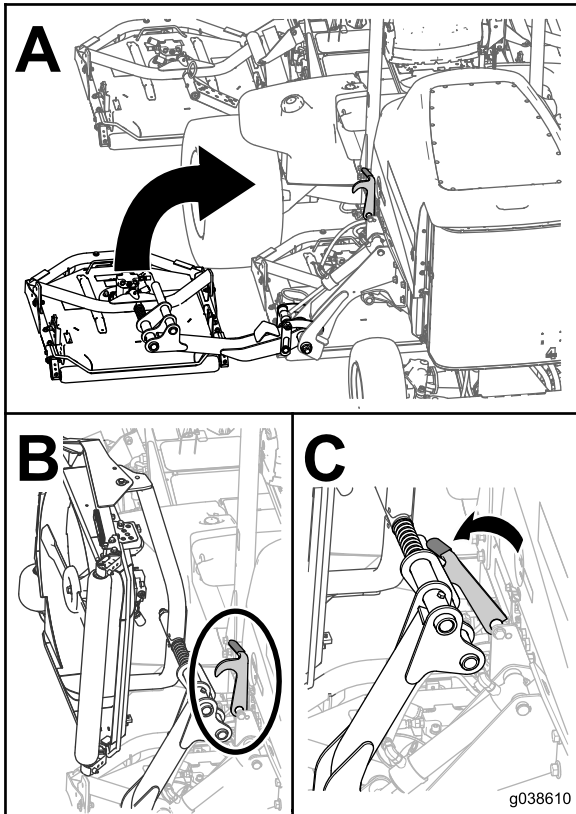

Figure 63

# Operating Tips

## Operating the Machine

- Start the engine. If the AUTO IDLE function is turned off, run it at HALF IDLE until it warms up. Run the engine at HIGH IDLE, lift the mower decks, disengage the parking brake, press the forward traction pedal, and carefully drive to an open area.
  - Practice moving forward and reverse, and starting and stopping the machine. To stop the machine, remove your foot from the traction pedal and let it return to NEUTRAL or press down on the reverse pedal.
- Note:** When going downhill in the machine, you may need to use the reverse pedal to stop.
- When possible, mow up and down hills rather than across them. Have the mower decks lowered when going down a hill to maintain steering control. Do not attempt to turn the machine on a hill.
  - Practice driving around obstacles with the mower decks up and down. Be careful when driving between narrow objects so that you do not damage the machine or mower decks.
  - Always drive slowly in rough areas.
  - If an obstacle is in the way, lift the mower decks to mow around it.
  - When transporting the machine from 1 work area to another, raise the mower decks to the fully upward position, shut off the PTO, press the mow/transport switch to the TRANSPORT position, and press up the engine-speed switch to set the engine to high-idle speed.

## Changing Mowing Patterns

Change mowing patterns often to minimize a poor after-cut appearance from repeatedly mowing in the same direction.

## Understanding Counterbalance

The counterbalance system maintains hydraulic back pressure on the cutting unit-lift cylinders. This counterbalance pressure transfers cutting-unit weight to the machine drive wheels to improve traction. The counterbalance pressure has been set at the factory to an optimal balance of after-cut appearance and traction capability in most turf conditions. Decreasing the counterbalance setting can produce a more stable cutting unit but can decrease the traction capability. Increasing the counterbalance setting can increase the traction capability, but may result in a poor after-cut appearance; refer to [Setting the Counterbalance \(page 21\)](#).

## Resolving After-Cut Appearance

Refer to the *After-cut Appearance Troubleshooting Guide* available at [www.Toro.com](http://www.Toro.com).

## Using Proper Mowing Techniques

- To begin cutting, engage the mower decks, then approach the mowing area slowly. Once the front mower decks are over the mowing area, lower the mower decks.
- To achieve the professional straight-line cut and striping that is desirable for some applications, find a tree or other object in the distance and drive straight toward it.
- As soon as the front mower decks reach the edge of the mowing area, lift the mower decks, and perform a teardrop-shaped turn to quickly line up for your next pass.
- Bolt-in mulching baffles are available for the mower decks. The mulching baffles perform well when you maintain turf on a regular schedule to avoid removing more than 25 mm (1 inch) of growth per cutting. When you cut too much growth with the mulching baffles installed, the after-cut appearance may deteriorate and the observed power to cut the turf increases. The mulching baffles also perform well for shredding leaves in the fall.

## Mowing When the Grass Is Dry

Mow either in the late morning to avoid the dew, which causes grass clumping, or late afternoon to avoid the damage that direct sunlight can cause on the sensitive, freshly mowed grass.

## Selecting the Proper Height-of-Cut Setting to Suit Conditions

Remove no more than approximately 25 mm (1 inch), or 1/3 of the grass blade when cutting. In exceptionally lush and dense grass, you may need to raise your height-of-cut setting.

## Mowing with Sharp Blades

A sharp blade cuts cleanly and without tearing or shredding the grass blades like a dull blade. Tearing and shredding causes the grass to turn brown at the edges, which impairs growth and increases susceptibility to diseases. Ensure that the blade is in good condition and that there is a full sail.

## Checking the Condition of the Mower Deck

Ensure that the cutting chambers are in good condition. Straighten any bends in the chamber components to ensure correct blade tip/chamber clearance.

## Maintaining the Machine after Mowing

After mowing, thoroughly wash the machine with a garden hose with no nozzle to avoid contamination and damage to the seals and bearings caused by excessive water pressure. Ensure that the radiator and oil cooler are kept free of dirt or grass clippings. After cleaning, inspect the machine for possible hydraulic-fluid leaks, damage, or wear to the hydraulic and mechanical components, and check the cutting-unit blades for sharpness.

## Understanding Turnaround-Mode

The turnaround-mode allows you convenient, 1-touch control to raise the cutting units above the turf while temporarily stopping the blades, allowing you to focus on driving the machine at the end of a mowing pass, or while navigating other obstacles.

- Set the turnaround-mode to the ON position by momentarily pressing the lift switch rearward ([Figure 10](#)), which automatically raises all cutting units from the float position to a preset height and disengages the PTO. To resume mowing, press the lift switch forward. All cutting units lower, and the PTO start again.
- Setting the turnaround-mode to the OFF position allows you to manually raise the cutting units from the float position by pressing and holding all lift switches rearward until the cutting units raise to the desired height. For Groundsmaster 4700 machines, press all 3 lift switches to raise all 7 cutting units ([Figure 10](#)). The PTO does not disengage until the cutting units raise to the same preset height to which the cutting units raise when the turnaround-mode is set to ON.

**Note:** The default the turnaround-mode feature is ON.

# After Operation

## After Operation Safety

- Clean grass and debris from the cutting units, mufflers, and engine compartment to help prevent fires. Clean up oil or fuel spills.
- If the cutting units are in the transport position, use the positive mechanical lock (if available) before you leave the machine unattended.
- Allow the engine to cool before storing the machine in any enclosure.
- Shut off the fuel before storing or transporting the machine.
- Never store the machine or fuel container where there is an open flame, spark, or pilot light, such as on a water heater or on other appliances.
- Keep all parts of the machine in good working condition and all hardware tightened, especially blade-attachment hardware.
- Replace all worn or damaged decals.

## Using the Cutting-Unit Storage Lanyard

Use the cutting-unit storage lanyards to prevent the forward outer cutting units from settling when the machine is parked overnight or if it is being stored for an extensive period. You can also use the cutting-unit storage lanyards to prevent the cutting units from floating while the machine is transporting between mowing tasks.

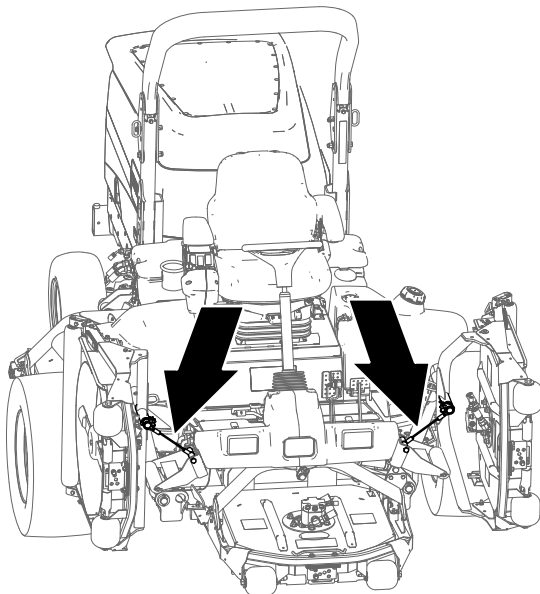
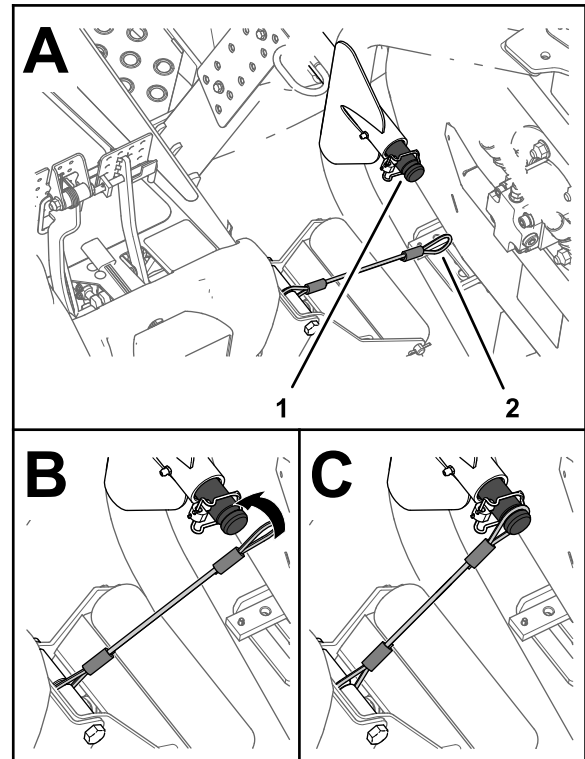

Figure 64

g225484

## Securing the Cutting Units

1. Ensure that the PTO is disengaged.
2. Park the machine on a level surface.
3. Engage the parking brake.
4. Fully raise the cutting units.
5. Align the lanyard to the carrier shaft of the lift arm for the forward outer-cutting unit (Figure 65).



g225483

Figure 65

1. Carrier-shaft groove (forward outer-lift arm)
2. Lanyard loop

6. Slip the loop in the lanyard over the carrier shaft until the lanyard is fully seated in the groove in the shaft (Figure 65).
7. Repeat steps 5 and 6 for the forward outer-cutting unit at the other side of the machine.

**Important:** Remove the lanyards from the carrier shafts before lowering the cutting units

## Stowing the Lanyards

**Note:** Stow the lanyards when you are not using them.

1. Ensure that the PTO is disengaged.
2. Park the machine on a level surface.
3. Engage the parking brake.



- With the cutting units lowered, slip the loop of the lanyard into the slot in the reinforcement plate of the roller support (Figure 66).

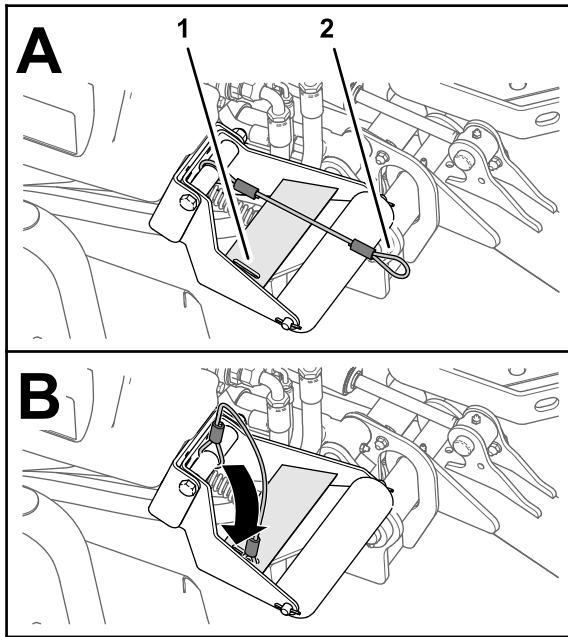

Figure 66

- Reinforcement-plate slot
- Lanyard loop (roller support)

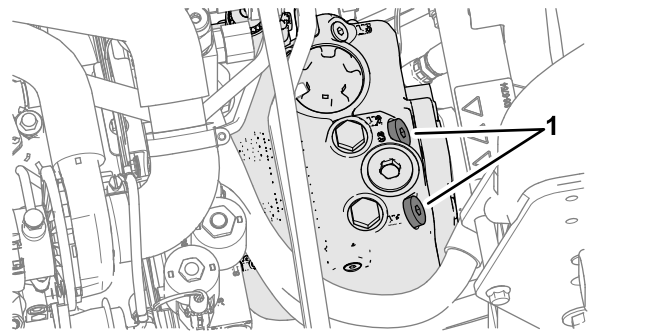
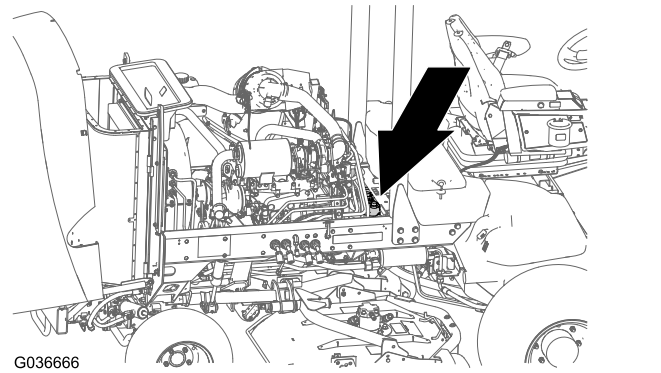

Figure 67

- Bypass valves
- Rotate each valve 3 turns counter-clockwise to open and allow the oil to bypass internally.  
**Note:** Do not open more than 3 turns. Because fluid is bypassed, you can slowly move the machine without damaging the transmission.
- Push or tow the machine forward.  
**Important:** If you must push or tow the machine in reverse, refer to the Reverse Tow Kit (Part No. 136-3620).
- Close the bypass valves before starting the engine.
- Torque to 70 N·m (52 ft·lb) to close the valve.

## Hauling the Machine

- Use care when loading or unloading the machine into a trailer or a truck.
- Use full-width ramps for loading the machine into a trailer or a truck.
- Tie the machine down securely.

## Pushing or Towing the Machine

In an emergency, the machine can be moved forward by actuating the bypass valve in the variable-displacement hydraulic pump and pushing or towing the machine.

**Important:** Do not push or tow the machine faster than 3 to 4.8 km/h (2 to 3 mph), because you may damage the transmission. The bypass valves must be open whenever you push or tow the machine.

- Open the hood and locate the bypass valves (Figure 67) on the top of pump, behind the battery and storage boxes.

# Locating the Tie-Down Points

**Note:** Use properly-rated DOT-approved straps in 4 corners to tie down the machine.

- On each side of the frame by the operator's platform
- On the rear bumper

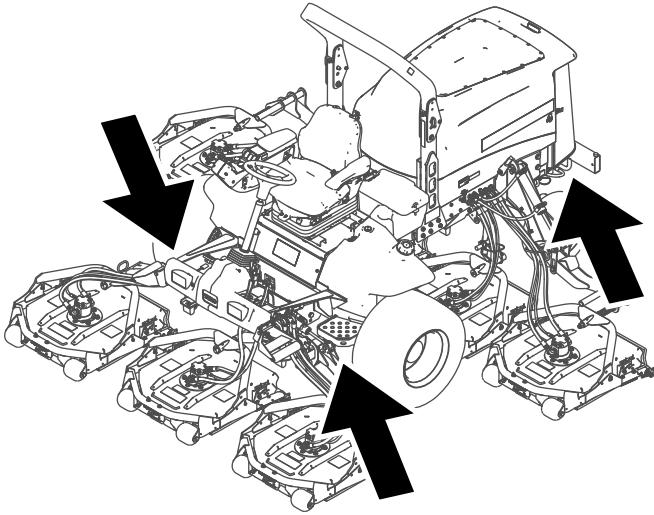

Figure 68

g208989

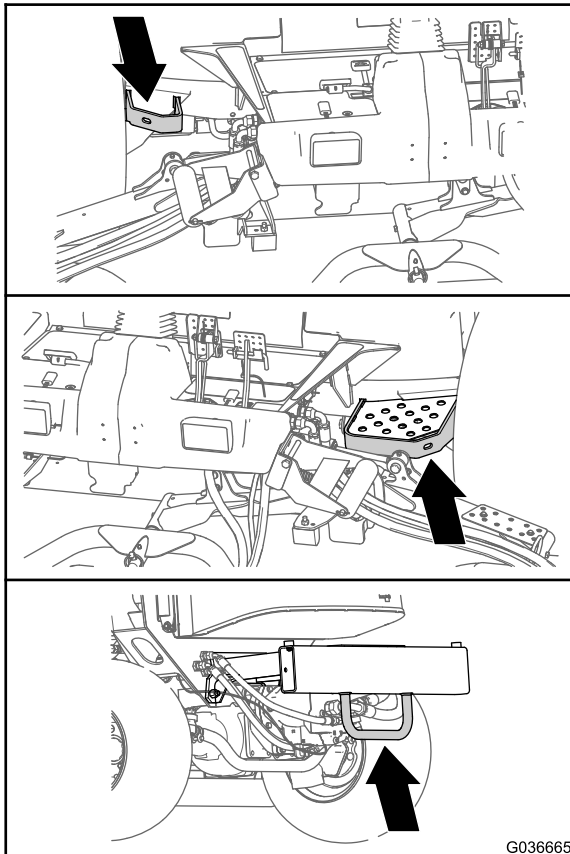

Figure 69

G036665

g036665

# Maintenance

**Important:** Refer to your engine owner's manual for additional maintenance procedures.

**Important:** If you are performing maintenance on the machine and run the engine with an engine exhaust-extraction duct, set the inhibit regen setting to ON; refer to [Setting the Inhibit Regen \(page 38\)](#).

**Note:** Download a free copy of the electrical or hydraulic schematic by visiting [www.Toro.com](http://www.Toro.com) and searching for your machine from the Manuals link on the home page.

**Note:** Determine the left and right sides of the machine from the normal operating position.

## Recommended Maintenance Schedule(s)

Maintenance Service Interval	Maintenance Procedure
After the first hour	<ul style="list-style-type: none"> <li>• Torque the wheel lug nuts.</li> </ul>
After the first 10 hours	<ul style="list-style-type: none"> <li>• Torque the wheel lug nuts.</li> </ul>
After the first 50 hours	<ul style="list-style-type: none"> <li>• Change the engine oil and filter.</li> </ul>
After the first 200 hours	<ul style="list-style-type: none"> <li>• Change the front planetary-gear oil.</li> <li>• Change the rear-axle lubricant.</li> <li>• Change the hydraulic filters.</li> </ul>
Before each use or daily	<ul style="list-style-type: none"> <li>• Check the tire pressure.</li> <li>• Check the interlock switches.</li> <li>• Check the blade stopping time.</li> <li>• Check the engine-oil level.</li> <li>• Drain water or other contaminants from the fuel filter/water separator</li> <li>• Check the rear axle and rear-axle gearbox for leaks.</li> <li>• Check level of coolant at the beginning of each day.</li> <li>• Remove debris from the engine area, oil cooler, and radiator (clean them more frequently in dirty conditions).</li> <li>• Check the hydraulic-fluid level.</li> <li>• Inspect the hydraulic lines and hoses for leaks, kinked lines, loose mounting supports, wear, loose fittings, weather deterioration, and chemical deterioration.</li> </ul>
Every 50 hours	<ul style="list-style-type: none"> <li>• Grease the bearings and bushings (also after every washing).</li> <li>• Check the battery condition.</li> </ul>
Every 100 hours	<ul style="list-style-type: none"> <li>• Check the condition and tension of the alternator belt.</li> </ul>
Every 200 hours	<ul style="list-style-type: none"> <li>• Torque the wheel lug nuts.</li> </ul>
Every 250 hours	<ul style="list-style-type: none"> <li>• Change the engine oil and filter.</li> </ul>
Every 400 hours	<ul style="list-style-type: none"> <li>• Service the air cleaner (earlier if the air cleaner indicator shows red, and more frequently in extremely dirty or dusty conditions).</li> <li>• Inspect the fuel lines and connections.</li> <li>• Replace the fuel-filter canister.</li> <li>• Replace the engine fuel filter.</li> <li>• Check for end-play in the planetary drives.</li> <li>• Check the planetary-gear-drive oil level (check if you notice external leakage).</li> <li>• Check the rear-axle lubricant.</li> <li>• Check the rear-axle-gear-box lubricant.</li> </ul>
Every 800 hours	<ul style="list-style-type: none"> <li>• Drain and clean the fuel tank.</li> <li>• Change the front planetary-gear oil or yearly, whichever comes first.</li> <li>• Change the rear-axle lubricant.</li> <li>• Check the rear wheel toe-in.</li> <li>• Change the hydraulic fluid.</li> <li>• Change the hydraulic filters.</li> </ul>

Maintenance Service Interval	Maintenance Procedure
Every 6,000 hours	<ul style="list-style-type: none"> <li>Disassemble, clean, and assemble the soot filter of the DPF or clean the soot filter if engine faults SPN 3251 FMI 0, SPN 3720 FMI 0, or SPN 3720 FMI 16 display in the InfoCenter.</li> </ul>
Before storage	<ul style="list-style-type: none"> <li>Drain and clean the fuel tank.</li> <li>Check the tire pressure.</li> <li>Check all fasteners.</li> <li>Grease or oil all grease fittings and pivot points.</li> <li>Paint chipped surfaces.</li> </ul>
Every 2 years	<ul style="list-style-type: none"> <li>Replace the hydraulic hoses.</li> </ul>

### **▲ CAUTION**

If you leave the key in the key switch, someone could accidentally start the engine and seriously injure you or other bystanders.

Remove the key before you do any maintenance.

## Daily Maintenance Checklist

Duplicate this page for routine use.

Maintenance Check Item	For the week of:						
	Monday	Tuesday	Wednesday	Thursday	Friday	Saturday	Sunday
Check the safety-interlock operation.							
Check the brake operation.							
Check the engine-oil level.							
Check the cooling-system-fluid level.							
Drain the water/fuel separator.							
Check the air filter, dust cup, and burp valve.							
Check for unusual engine noises. <sup>1</sup>							
Check the radiator and screen for debris							
Check for unusual operating noises.							
Check the hydraulic-fluid level.							
Check the hydraulic hoses for damage.							
Check for fluid leaks.							
Check the fuel level.							
Check the tire pressure.							
Check the instrument operation.							
Check the height-of-cut adjustment.							

Maintenance Check Item	For the week of:						
	Monday	Tuesday	Wednesday	Thursday	Friday	Saturday	Sunday
Lubricate all the grease fittings. <sup>2</sup>							
Touch up any damaged paint.							
<sup>1</sup> Check the glow plug and injector nozzles if starting is hard, there is excess smoke, or rough running is noted. <sup>2</sup> Immediately <b>after every</b> washing, regardless of the interval listed.							

**Important:** Refer to your engine operator’s manual for additional maintenance procedures.

### Notation for Areas of Concern

Inspection performed by:		
Item	Date	Information

## Pre-Maintenance Procedures

### Maintenance Safety

- Before adjusting, cleaning, repairing, or leaving the machine, do the following:
  - Park the machine on a level surface.
  - Move the throttle switch to the low-idle position.
  - Disengage the cutting units.
  - Lower the cutting units.
  - Ensure that the traction is in neutral.
  - Engage the parking brake.
  - Shut off the engine and remove the key.
  - Wait for all moving parts to stop.
  - Allow machine components to cool before performing maintenance.
- If the cutting units are in the transport position, use the positive mechanical lock (if available) before you leave the machine unattended.
- If possible, do not perform maintenance while the engine is running. Keep away from moving parts.
- Use jack stands to support the machine or components when required.
- Carefully release pressure from components with stored energy.

## Preparing the Machine for Maintenance

1. Ensure that the PTO is disengaged.
2. Park the machine on a level surface.
3. Engage the parking brake.
4. Lower the cutting unit(s) if necessary.
5. Shut off the engine and wait for all moving parts to stop.
6. Turn the ignition key to the STOP position and remove it.
7. Allow machine components to cool before performing maintenance.

## Lifting the Machine

Use the following as points to lift the machine:

**Front of the machine**—at the frame of the machine, forward of the wheel-drive motors (Figure 70)

**Important:** Do not support the machine at the wheel-drive motors. Keep the lifting equipment clear of hydraulic tubing and hoses.

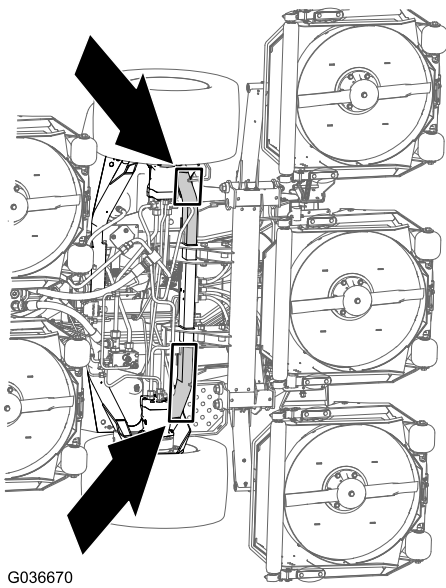

G036670

Figure 70

g036670

## Opening the Hood

Tilt the hood to access the chassis as shown in [Figure 72](#).

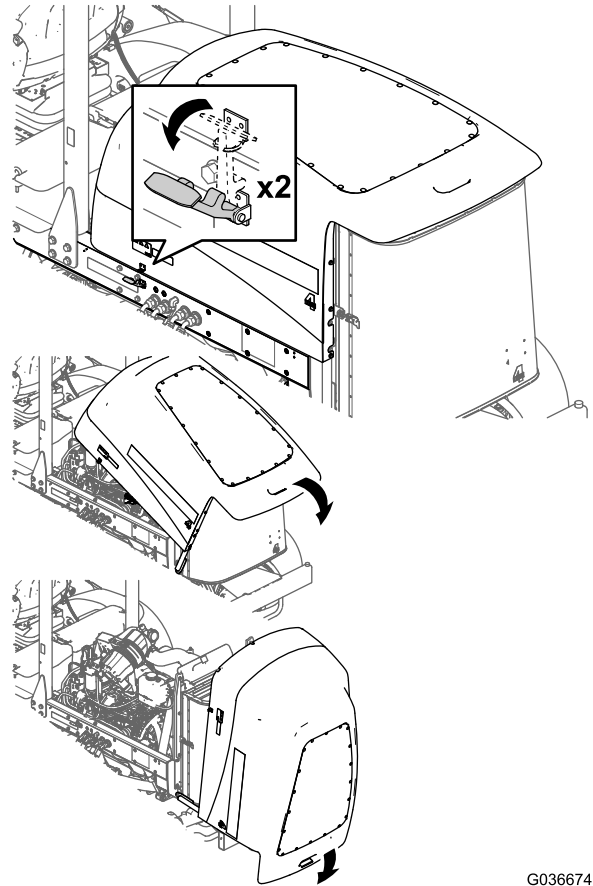

G036674

g036674

Figure 72

**Rear of the machine**—at the center of the axle ([Figure 71](#))

Locate the jackstands of the specified capacity at both sides of the gear case and under the axle.

**Important:** Do not support the machine at the tie rod.

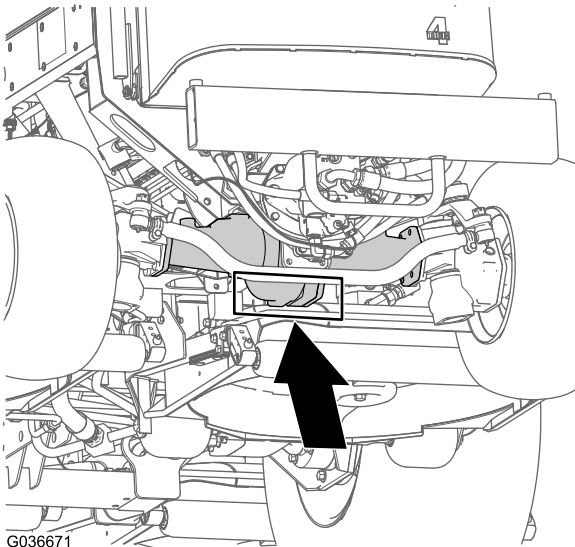

G036671

Figure 71

g036671

# Accessing the Hydraulic Lift Compartment

Tilt the seat to access the hydraulic lift compartment as shown in [Figure 73](#).

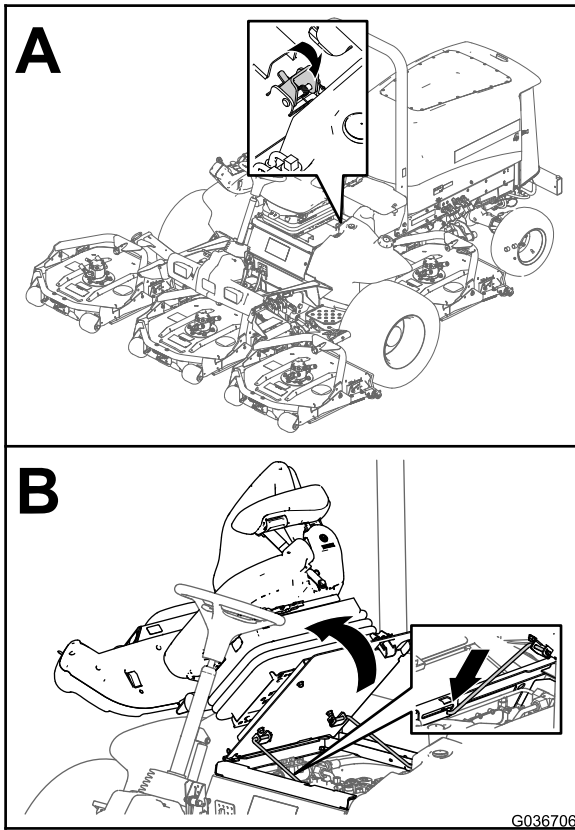

Figure 73

# Lubrication

## Greasing the Bearings and Bushings

**Service Interval:** Every 50 hours (also after every washing).

**Grease specification:** No. 2 lithium grease

The grease fitting locations and quantities are as follows:

- Brake-shaft pivot bearings (5) as shown in [Figure 74](#)

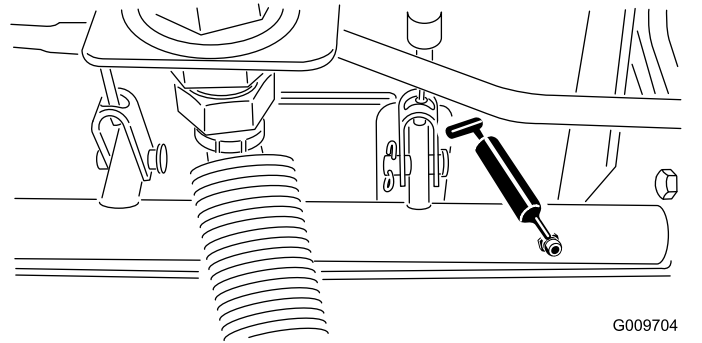

Figure 74

- Rear-axle-pivot bushings (2) as shown in [Figure 75](#)

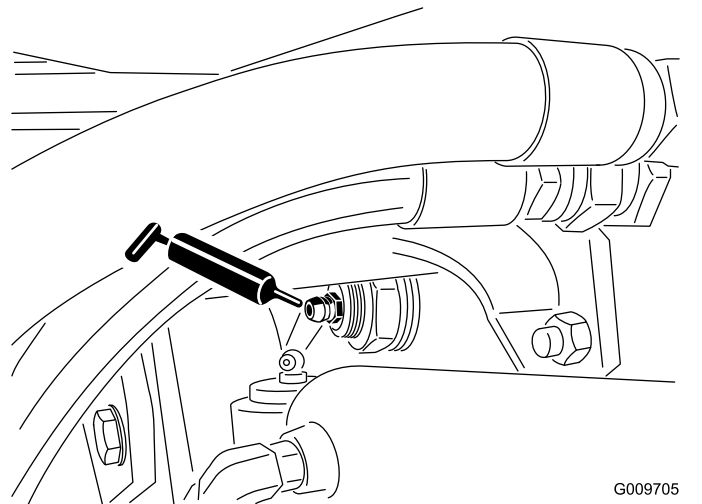
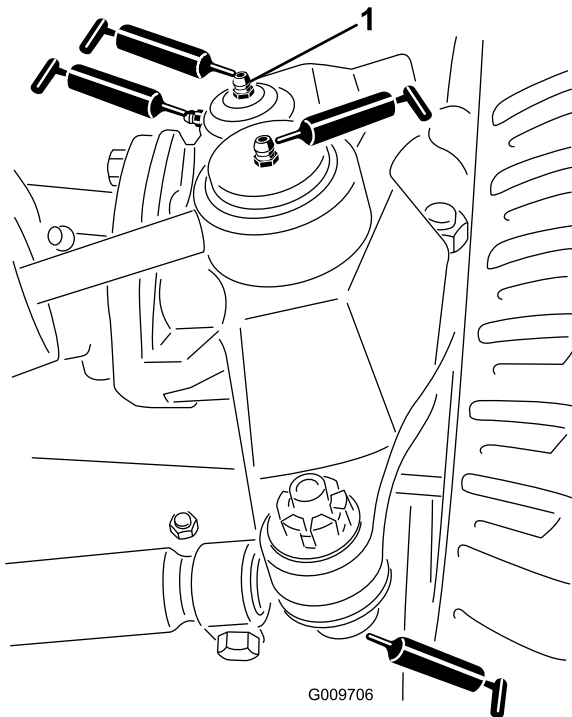

Figure 75

- Steering-cylinder ball joints (2) as shown in [Figure 76](#)



**Figure 76**

- Top fitting on kingpin

- Tie-rod ball joints (2) as shown in [Figure 76](#)
- Kingpin bushings (2) as shown in [Figure 76](#)

**Important:** Lubricate the top fitting on the kingpin no more than annually (2 pumps).

- Lift-arm bushings (1 per cutting unit) as shown in [Figure 77](#)

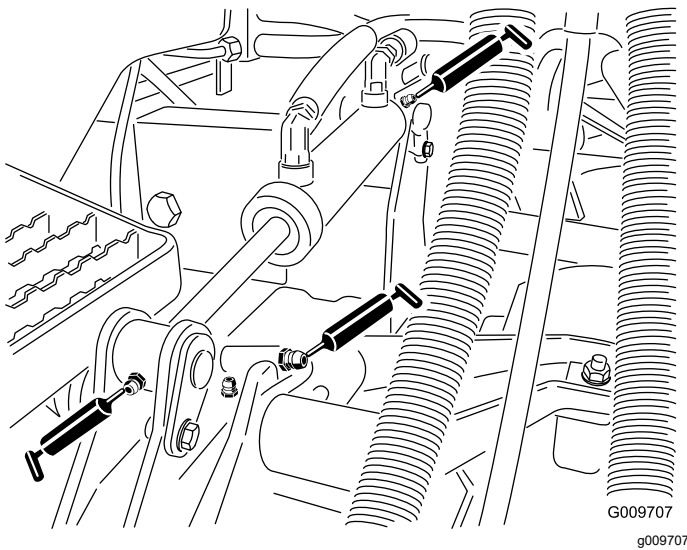
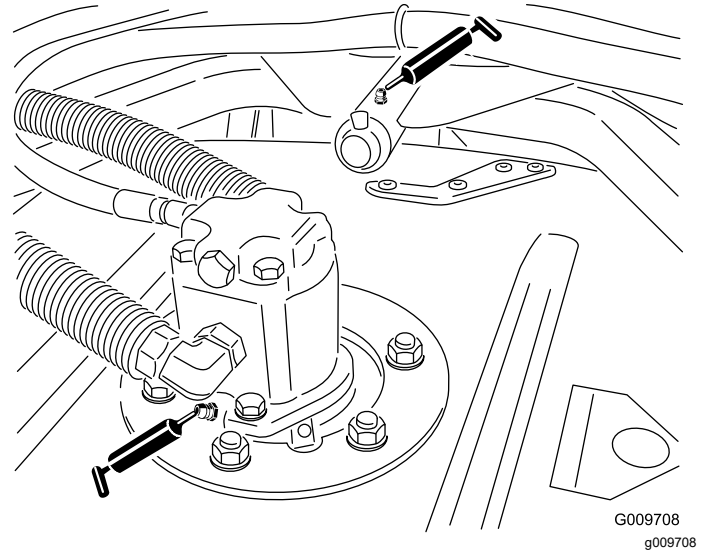

**Figure 77**

- Lift-cylinder bushings (2 per cutting unit) as shown in [Figure 77](#)

- Cutting-unit spindle-shaft bearings (2 per cutting unit) as shown in [Figure 78](#)

**Note:** You can use either fitting, whichever is more accessible. Pump grease into the fitting until a small amount appears at the bottom of the spindle housing (under the cutting unit).



**Figure 78**

- Cutting-unit carrier-arm bushings (1 per cutting unit) as shown in [Figure 78](#)
- Rear roller bearings (2 per cutting unit) as shown in [Figure 79](#)

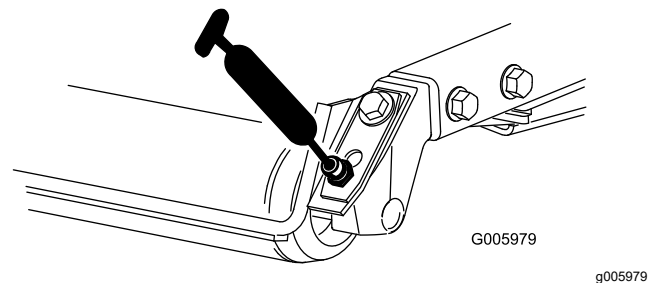

**Figure 79**

**Important:** Make sure that the grease groove in each roller mount aligns with the grease hole in each end of the roller shaft. To help align the groove and the hole, there is also an alignment mark on 1 end of the roller shaft.



# Engine Maintenance

## Engine Safety

- Shut off the engine and remove the key before checking the oil or adding oil to the crankcase.
- Do not change the governor speed or overspeed the engine.

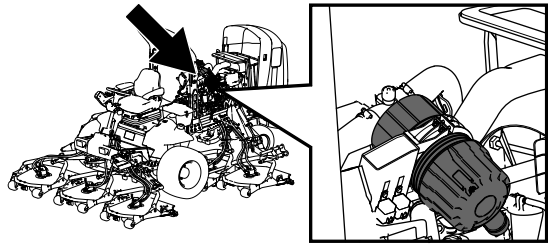

g198631

## Servicing the Air Cleaner

**Service Interval:** Every 400 hours

Check the air-cleaner body for damage which could cause an air leak. Replace it if it is damaged. Check the whole intake system for leaks, damage, or loose hose clamps.

Service the air-cleaner filter only when the service indicator (Figure 80) requires it. Changing the air filter before it is necessary only increases the chance of dirt entering the engine when you remove the filter.

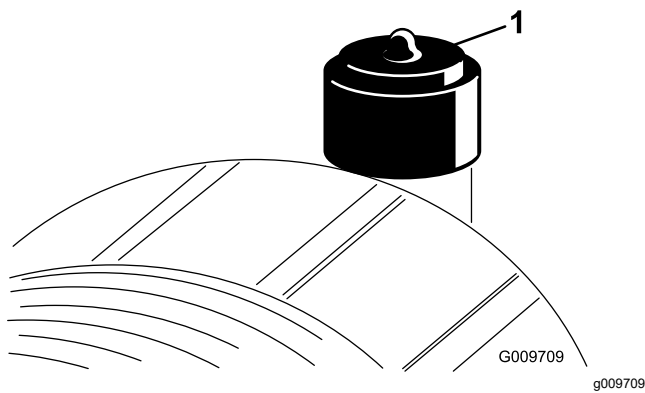

Figure 80

1. Air-cleaner indicator

**Important:** Be sure that the cover is seated correctly and seals with the air-cleaner body.

1. Replace the air cleaner (Figure 81).

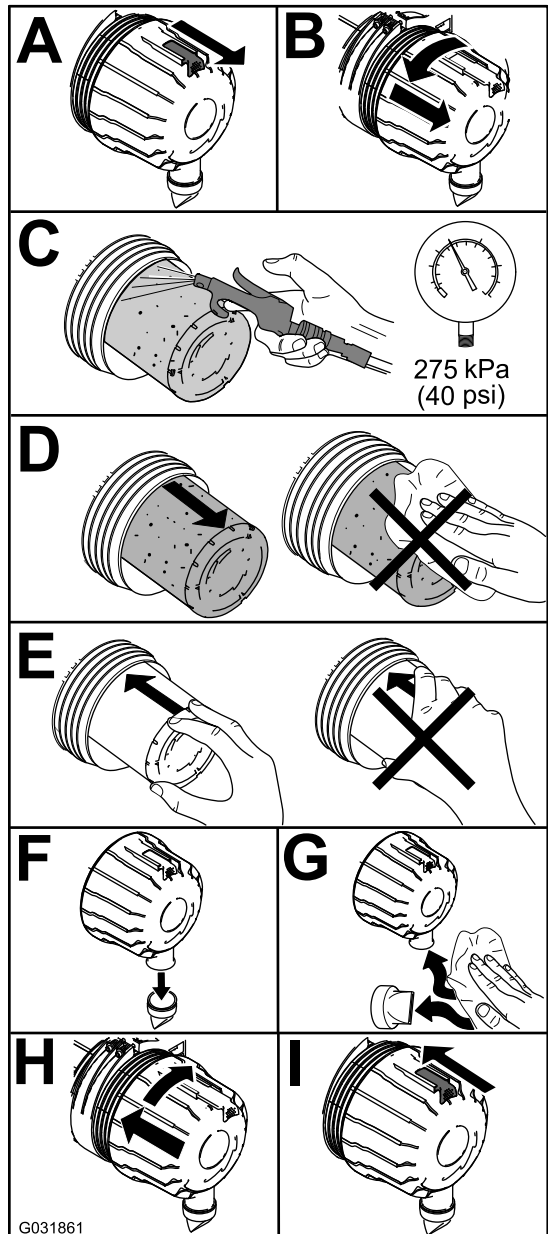

Figure 81

**Note:** Do not clean a used element because cleaning it can damage the filter media.

**Important:** Never attempt to clean the safety filter (Figure 82). Replace the safety filter after every 3 primary filter services.

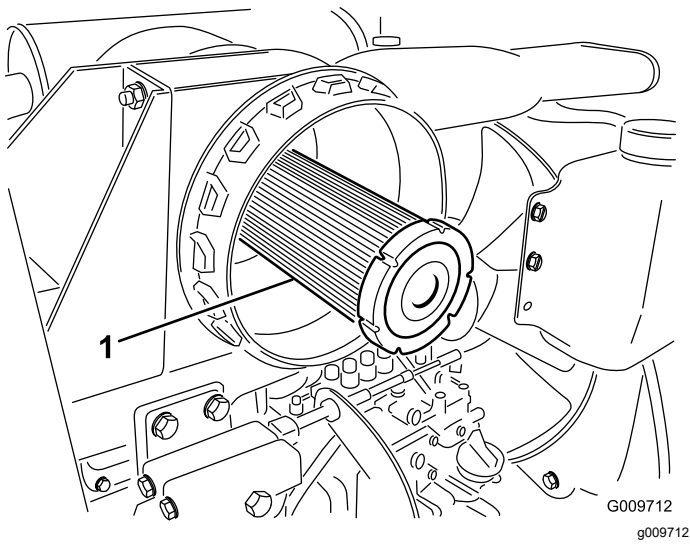

Figure 82

1. Air-cleaner safety filter
- 
2. Reset the indicator (Figure 80) if it shows red.

## Servicing the Engine Oil

### Oil Specification

Use high-quality, low-ash engine oil that meets or exceeds the following specifications:

- API service category CJ-4 or higher
- ACEA service category E6
- JASO service category DH-2

**Important:** Using engine oil other than API CJ-4 or higher, ACEA E6, or JASO DH-2 may cause the diesel particulate filter to plug or cause engine damage.

Use the following engine oil viscosity grade:

- Preferred oil: SAE 15W-40 (above 0°F)
- Alternate oil: SAE 10W-30 or 5W-30 (all temperatures)

Toro Premium Engine Oil is available from your authorized Toro distributor in either 15W-40 or 10W-30 viscosity grades. See the *Parts Catalog* for part numbers.

### Checking the Engine-Oil Level

**Service Interval:** Before each use or daily

The engine is shipped with oil in the crankcase; however, the oil level must be checked before and after the engine is first started.

**Important:** Check the engine oil daily. If the engine-oil level is above the Full mark on the dipstick, the engine oil may be diluted with fuel;

**If the engine oil level is above the Full mark, change the engine oil.**

The best time to check the engine oil is when the engine is cool before it has been started for the day. If it has already been run, allow the oil to drain back down to the sump for at least 10 minutes before checking. If the oil level is at or below the Add mark on the dipstick, add oil to bring the oil level to the Full mark. **Do not overfill the engine with oil.**

**Important:** Keep the engine-oil level between the upper and lower limits on the dipstick; the engine may fail if you run it with too much or too little oil.

Check the engine-oil level; refer to Figure 83.

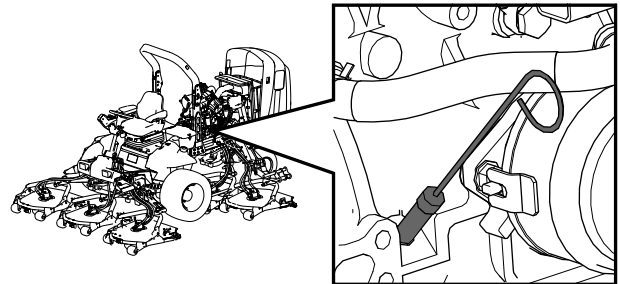

g198647

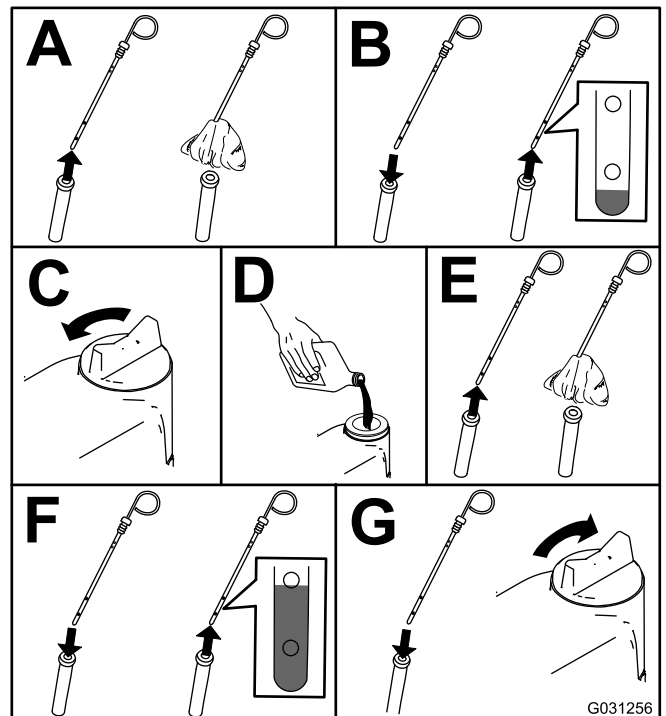

g031256

Figure 83

**Note:** When using different oil, drain all old oil from the crankcase before adding new oil.

## Crankcase Oil Capacity

Approximately 5.7 L (6 US qt) with the filter.

## Changing the Engine Oil and Filter

**Service Interval:** After the first 50 hours

Every 250 hours

**Crankcase oil capacity:** approximately 5.7 L (6 US qt) with the filter.

1. Start the engine and let it run 5 minutes to allow the oil to warm up.
2. Park the machine on a level surface, engage the parking brake, shut off the engine, and remove the key.
3. Replace the engine oil and filter (Figure 84).

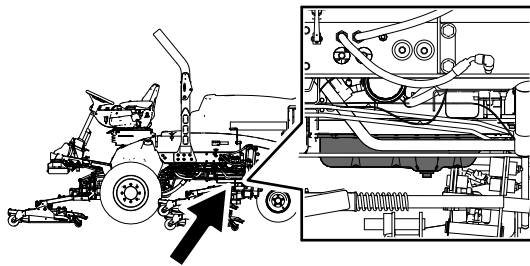

g198660

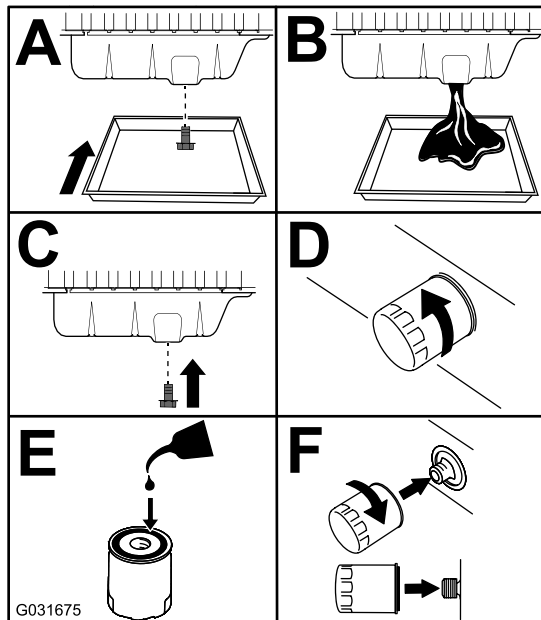

G031675

g031675

Figure 84

## Servicing the Diesel-Oxidation Catalyst (DOC) and the Soot Filter

**Service Interval:** Every 6,000 hours—Disassemble, clean, and assemble the soot filter of the DPF or clean the soot filter if engine faults SPN 3251 FMI 0, SPN 3720 FMI 0, or SPN 3720 FMI 16 display in the InfoCenter.

If engine faults CHECK ENGINE SPN 3251 FMI 0, CHECK ENGINE SPN 3720 FMI 0, or CHECK ENGINE SPN 3720 FMI 16 display in the InfoCenter (Figure 85), clean the soot filter using the steps that follow:

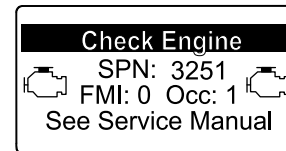

g214715

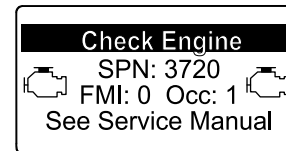

g213864

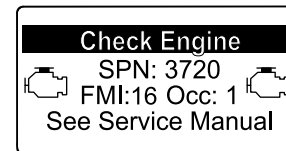

g213863

Figure 85

1. Refer to the Engine section in the *Service Manual* for information on disassembling and assembling the diesel-oxidation catalyst and the soot filter of the DPF.
2. Refer to your authorized Toro distributor for diesel-oxidation catalyst and the soot filter replacement parts or service.
3. Contact your authorized Toro distributor to reset the engine ECU after you install a clean DPF.

4. Add oil to the crankcase; refer to the [Crankcase Oil Capacity](#) (page 59) and [Checking the Engine-Oil Level](#) (page 58).

# Fuel System Maintenance

## **⚠ DANGER**

Under certain conditions, diesel fuel and fuel vapors are highly flammable and explosive. A fire or explosion from fuel can burn you and others and can cause property damage.

- Use a funnel to fill the fuel tank outdoors, in an open area, when the engine is off and is cold. Wipe up any fuel that spills.
- Do not fill the fuel tank completely full. Add fuel to the fuel tank until the level is 6 to 13 mm (1/4 to 1/2 inch) below the bottom of the filler neck. This empty space in the tank allows the fuel to expand.
- Never smoke when handling fuel, and stay away from an open flame or where fuel fumes may be ignited by a spark.
- Store fuel in a clean, safety-approved container and keep the cap in place.

## Draining the Fuel Tank

**Service Interval:** Every 800 hours—Drain and clean the fuel tank.

Before storage—Drain and clean the fuel tank.

In addition to the listed service interval, drain and clean the tank if the fuel system becomes contaminated or if you are storing the machine for an extended period. Use clean fuel to flush out the tank.

## Inspecting the Fuel Lines and Connections

**Service Interval:** Every 400 hours/Yearly (whichever comes first)

Inspect the fuel lines for deterioration, damage, or loose connections.

# Servicing the Fuel-Water Separator

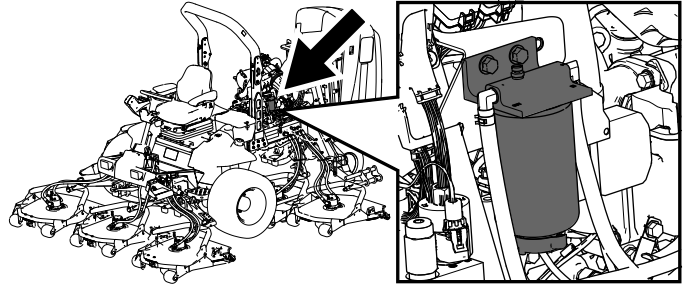

Figure 86

g198661

## Draining Water from the Fuel/Water Separator

**Service Interval:** Before each use or daily—Drain water or other contaminants from the fuel filter/water separator

Drain water from the fuel/water separator as shown in (Figure 87).

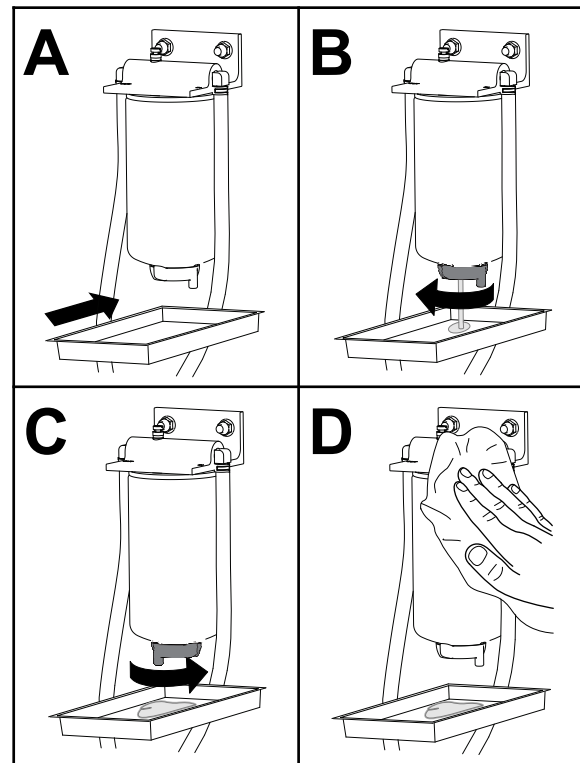

Figure 87

g225506

## Replacing the Fuel-Filter Canister

**Service Interval:** Every 400 hours—Replace the fuel-filter canister.

Replace the fuel-filter canister as shown in [Figure 88](#).

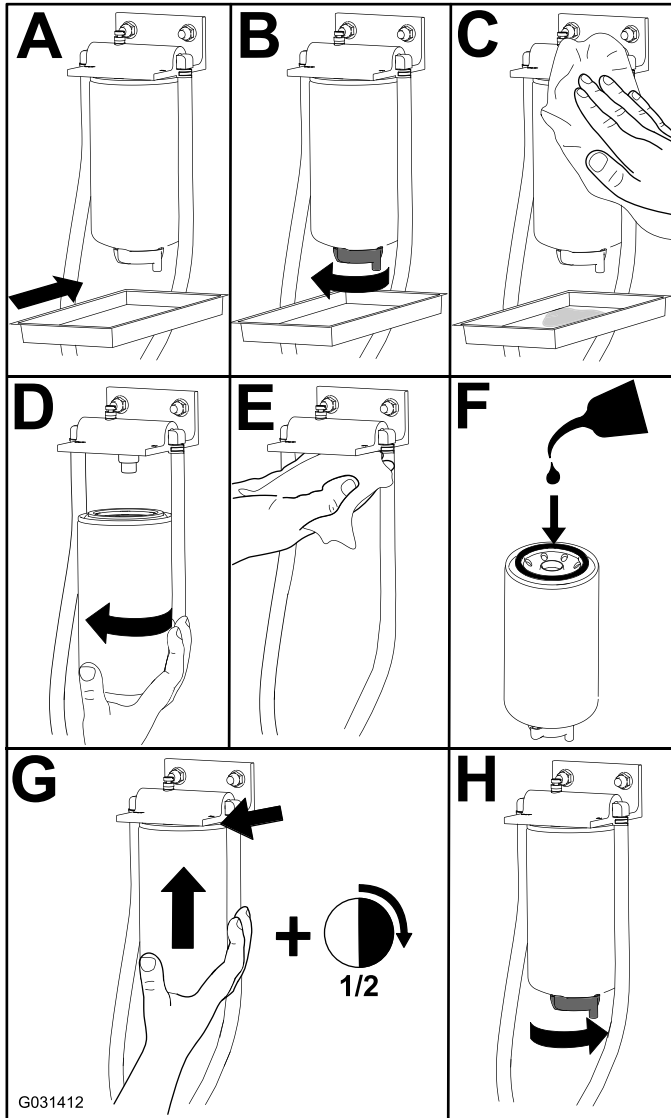

Figure 88

## Servicing the Fuel Filter

**Service Interval:** Every 400 hours

1. Clean the area around the fuel-filter head ([Figure 89](#)).

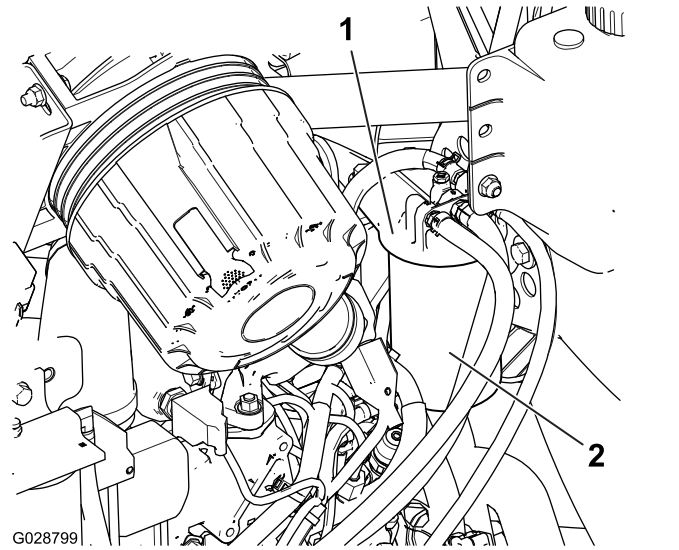

Figure 89

1. Fuel-filter head

2. Fuel filter

2. Remove the filter and clean the filter head mounting surface ([Figure 89](#)).
3. Lubricate the filter gasket with clean lubricating engine oil; refer to the engine owner's manual for additional information.
4. Install the dry filter canister, by hand, until the gasket contacts the filter head, then rotate it an additional 1/2 turn.
5. Start the engine and check for fuel leaks around the filter head.

## Cleaning the Fuel-Pickup Tube Screen

The fuel-pickup tube, located inside the fuel tank, is equipped with a screen to help prevent debris from entering the fuel system. Remove the fuel-pickup tube and clean the screen as required.

1. Remove the hose clamp that secures the fuel supply hose to the fitting of the fuel-pickup tube ([Figure 90](#)).

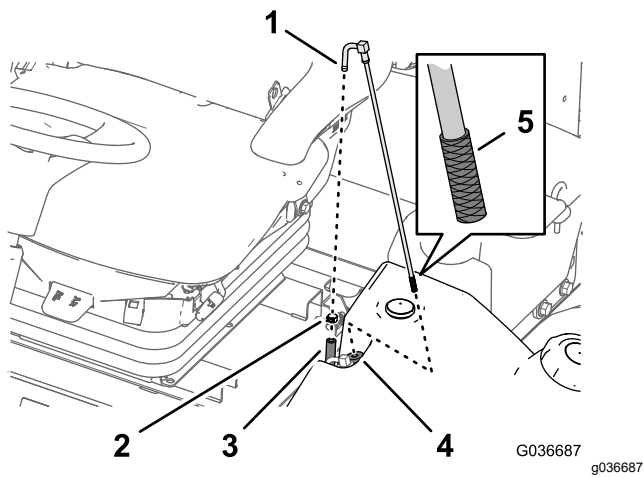

**Figure 90**

- |                               |                   |
|-------------------------------|-------------------|
| 1. Fitting (fuel-pickup tube) | 4. Rubber bushing |
| 2. Hose clamp                 | 5. Screen         |
| 3. Fuel supply hose           |                   |

2. Separate the hose from the fitting (Figure 90).
3. Lift the fuel-pickup tube from the fuel tank (Figure 90).
 

**Note:** Lift the tube straight from the bushing in the tank.
4. Clean any debris from the screen at the end of the fuel-pickup tube (Figure 90).
5. Insert the fuel-pickup tube through the rubber bushing and into the tank (Figure 90).
 

**Note:** Ensure that the fuel-pickup tube is fully seated into the rubber bushing.
6. Install the supply hose onto the fitting of the fuel-pickup tube, and secure the hose with the hose clamp that you removed in step 1.

## Priming the Fuel System

Prime the fuel system before starting the engine for the first time, after running out of fuel, or after fuel system maintenance (e.g., draining the filter/water separator, replacing a fuel hose).

To prime the fuel system, perform the following steps:

1. Ensure that fuel is in the fuel tank.
2. Turn the ignition key to the ON position for 10 to 15 seconds.

**Note:** This allows the fuel pump to prime the fuel system.

**Important:** Do not use the engine starter motor to crank the engine to prime the fuel system.

# Electrical System Maintenance

## Electrical System Safety

- Disconnect the battery before repairing the machine. Disconnect the negative terminal first and the positive last. Connect the positive terminal first and the negative last.
- Charge the battery in an open, well-ventilated area, away from sparks and flames. Unplug the charger before connecting or disconnecting the battery. Wear protective clothing and use insulated tools.

## Checking the Battery Condition

**Service Interval:** Every 50 hours

**Important:** Before welding on the machine, disconnect the negative cable from the battery to prevent damage to the electrical system. Also, you must disconnect the engine, InfoCenter, and machine controllers before welding on the machine.

**Note:** Keep the terminals and the entire battery case clean, because a dirty battery discharges slowly. To clean the battery, wash the entire case with a solution of baking soda and water. Rinse with clear water. Coat the battery posts and cable connectors with Grafo 112X (skin-over) grease (Toro Part No. 505-47) or petroleum jelly to prevent corrosion.

# Charging and Connecting the Battery

1. Unlatch and raise the operator's console panel (Figure 91).

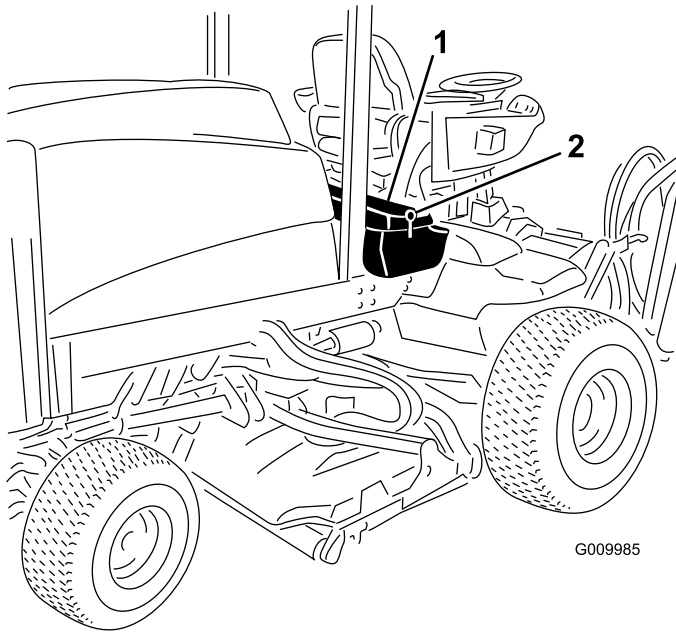

Figure 91

1. Operator's console panel
2. Latch

## **⚠ DANGER**

Battery electrolyte contains sulfuric acid, which is fatal if consumed and causes severe burns.

- Do not drink electrolyte and avoid contact with skin, eyes, or clothing. Wear safety glasses to shield your eyes and rubber gloves to protect your hands.
  - Fill the battery where clean water is always available for flushing the skin.
2. Remove the rubber boot from the positive terminal and inspect the battery.
  3. Remove the negative cable (black) from the negative (-) terminal and the positive cable (red) from the positive (+) terminal of the battery (Figure 92).

## **⚠ WARNING**

Incorrect battery cable routing could damage the machine and cables, causing sparks. Sparks can cause the battery gasses to explode, resulting in personal injury.

- Always disconnect the negative (black) battery cable before disconnecting the positive (red) cable.
- Always connect the positive (red) battery cable before connecting the negative (black) cable.

## **⚠ WARNING**

Battery terminals or metal tools could short against metal components, causing sparks. Sparks can cause the battery gasses to explode, resulting in personal injury.

- When removing or installing the battery, do not allow the battery terminals to touch any metal parts of the machine.
- Do not allow metal tools to short between the battery terminals and metal parts of the machine.

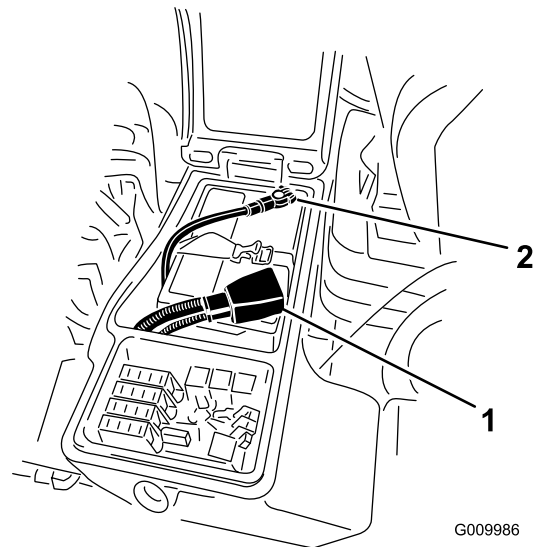

Figure 92

1. Positive battery cable
2. Negative battery cable

4. Connect a 3 to 4 A battery charger to the battery posts. Charge the battery at a rate of 3 to 4 A for 4 to 8 hours.

## ⚠ WARNING

Charging the battery produces gasses that can explode.

Never smoke near the battery and keep sparks and flames away from battery.

- When the battery is charged, disconnect the charger from the power outlet and battery posts.
- Install the positive cable (red) to the positive (+) terminal and the negative cable (black) to the negative (-) terminal of the battery (Figure 92).
- Secure the cables to the posts with bolts and nuts.

**Note:** Make sure that the positive (+) terminal is all the way on the post and the cable is positioned snug to the battery. The cable must not contact the battery cover.

- Coat both battery connections with Grafo 112X (skin-over) grease, Part No. 505-47, petroleum jelly, or light grease to prevent corrosion.
- Slide the rubber boot over the positive terminal.
- Close the console panel and secure the latch.

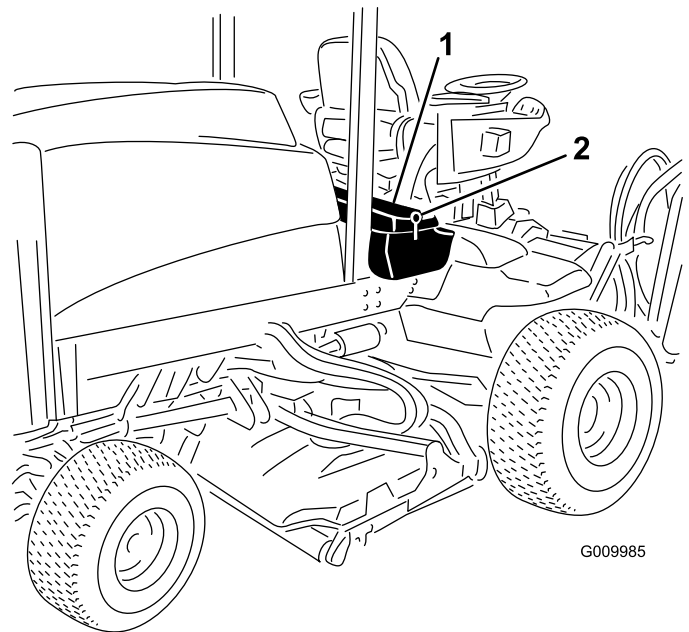

Figure 94

- Latch
- Right storage box

- Replace the open fuse(s) as needed (Figure 95).

## Locating the Fuses

The fuse block for the machine is located in the right storage box

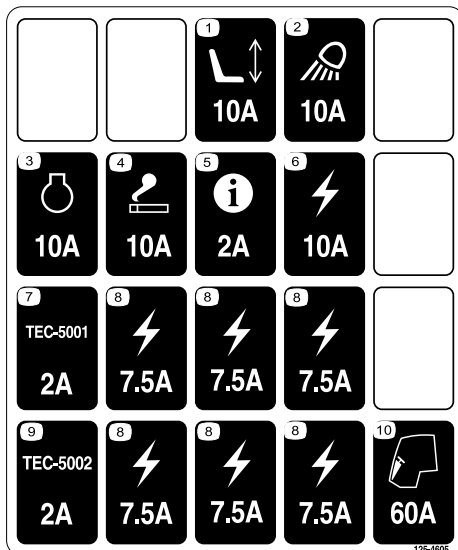

Figure 93

decal125-4605

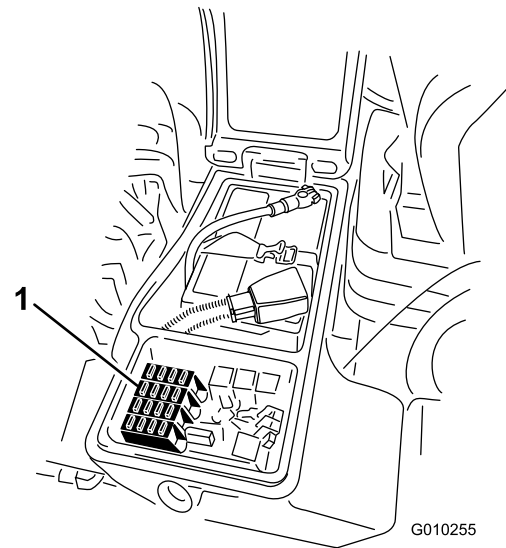

Figure 95

- Fuses

- Close the cover of the right storage box and secure the cover with the latch (Figure 94).

- Loosen the latch for the cover of the right storage box and raise the cover (Figure 94) to expose the fuse block (Figure 95).



# Drive System Maintenance

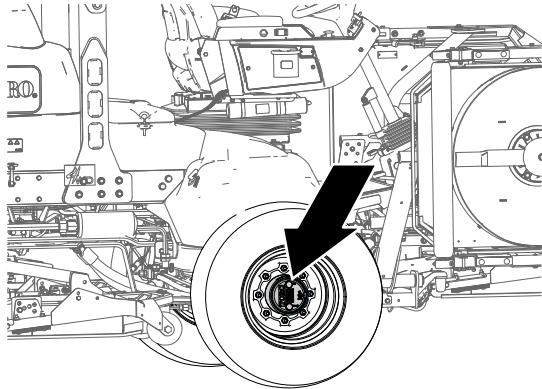

Figure 96

g225611

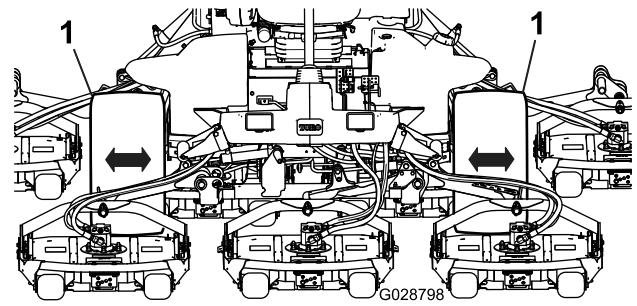

Figure 97

g028798

1. Front drive wheels

4. Repeat step 3 for the other drive wheel.
5. If either wheel moves, contact your authorized Toro distributor to have the planetary drive rebuilt.

## Checking for End-Play in the Planetary Drives

**Service Interval:** Every 400 hours

There should be no end-play in the planetary drives/drive wheels (i.e., the wheels should not move when you pull or push them in a direction parallel to the axle).

1. Park the machine on a level surface, engage the parking brake, lower the cutting units, shut off the engine, and remove the key.
2. Chock the rear wheels and raise the front of machine, supporting the front axle/frame on jack stands.

### **⚠ DANGER**

**A machine on a jack may be unstable and slip off the jack, injuring anyone beneath it.**

- Do not start the engine while the machine is on a jack.
  - Always remove the key from the switch before getting off the machine.
  - Block the tires when you are raising the machine with a jack.
  - Support the machine with jack stands.
3. Grasp 1 of the front drive wheels and push/pull it toward and away from the machine, noting any movement.

## Checking the Planetary Gear-Drive Lubricant

**Service Interval:** Every 400 hours (check if you notice external leakage).

**Lubricant Specification:** high quality SAE 85W-140 gear lubricant

1. Park the machine on level surface, position the wheel so that the fill plug is at the 12 o'clock position, the check plug is at 3 o'clock position, and the drain plug is at the 6 o'clock position (Figure 98).

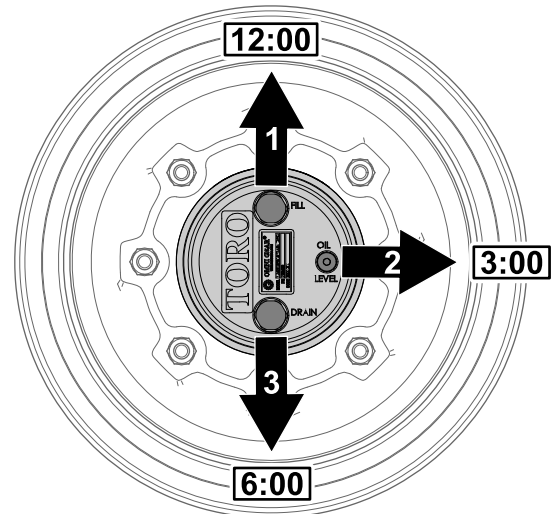

Figure 98

g225612

1. Fill plug (12 o'clock position)
2. Check plug (3 o'clock position)
3. Drain plug (6 o'clock position)

2. Remove the check plug at the 3 o'clock position (Figure 98).

The oil level should be at the bottom of the check-plug hole.

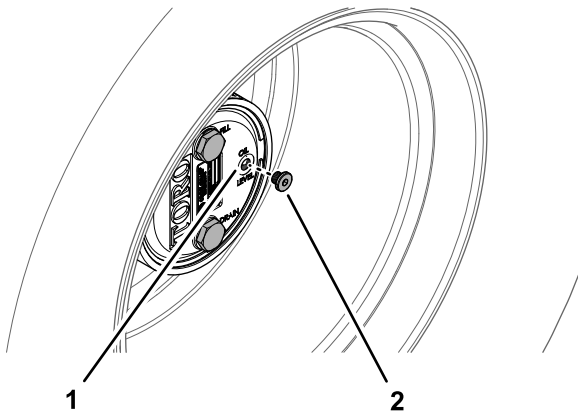

**Figure 99**

g225606

1. Check-plug hole
2. Check plug

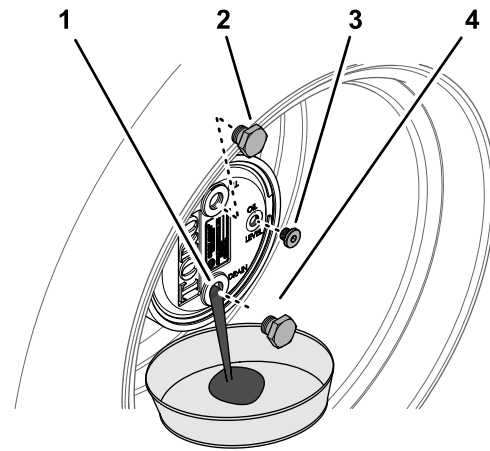

**Figure 100**

g225609

1. Drain-plug hole
2. Fill plug
3. Check plug
4. Drain plug

3. If the oil level is low, remove the fill plug at the 12 o'clock position and add oil until it begins to flow out of the hole at the 3 o'clock position.
4. Check the O-ring for the plug(s) for wear or damage.
 

**Note:** Replace the O-ring(s) as needed.
5. Install the plug(s).
6. Repeat steps 1 through 5 on the planetary gear assembly at the other side of the machine.

3. Place a drain pan under the planetary hub, remove the drain plug at the 6 o'clock position, and allow the oil to fully drain (Figure 100).
4. Check the O-rings for the fill, check, and drain plugs for wear or damage.
 

**Note:** Replace the O-ring(s) as needed.
5. Install the drain plug into the drain hole of the planetary housing (Figure 100).
6. Place a drain pan under the brake housing, remove the drain plug, and allow the oil to fully drain (Figure 101).

## Changing the Planetary-Gear-Drive Oil

**Service Interval:** After the first 200 hours

Every 800 hours or yearly, whichever comes first.

**Lubricant specification:** high quality SAE 85W-140 gear lubricant

**Planetary and brake housing lubrication capacity:** 0.65 L (22 fl oz)

### Draining the Planetary-Gear-Drive

1. Park the machine on level surface, position the wheel so that the fill plug is at the 12 o'clock position, the check plug is at 3 o'clock position, and the drain plug is at the 6 o'clock position; refer to Figure 98 in [Checking the Planetary Gear-Drive Lubricant](#) (page 65).
2. Remove the fill plug at the 12 o'clock position and the check plug at the 3 o'clock position (Figure 100).

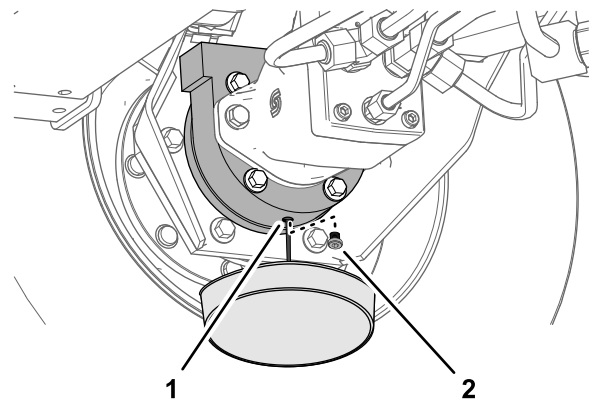

**Figure 101**

g225608

1. Drain hole (brake housing)
2. Drain plug

7. Check the O-ring for the plug for wear or damage and install the drain plug into the brake housing.
 

**Note:** Replace the O-ring as needed.

## Filling the Planetary-Gear-Drive with Lubricant

1. Through the fill-plug hole, slowly fill the planetary with 0.65 L (22 fl oz) of high quality SAE 85W-140 wt gear lube.

**Important:** If the planetary fills before the 0.65 L (22 fl oz) of oil is added, wait 1 hour or install the plug and move the machine approximately ten feet to distribute the oil through the brake system. Then, remove the plug and add the remaining oil.

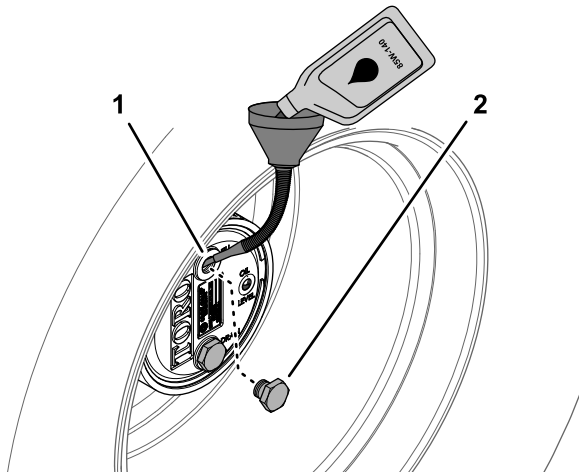

Figure 102

g225610

1. Fill-plug hole (planetary housing)
2. Fill plug

2. Install the fill plug and the check plug.
3. Wipe clean the planetary and brake housings (Figure 103).

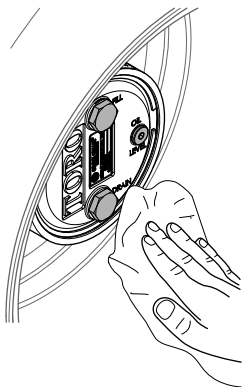

Figure 103

g225607

4. Repeat steps 1 through 7 in [Draining the Planetary-Gear-Drive \(page 66\)](#) and steps 1 through 3 in this procedure for the planetary/brake assembly at the other side of the machine.

## Checking the Rear Axle and Gearbox for Leaks

**Service Interval:** Before each use or daily

Visually inspect the rear axle and rear-axle gearbox for leaks.

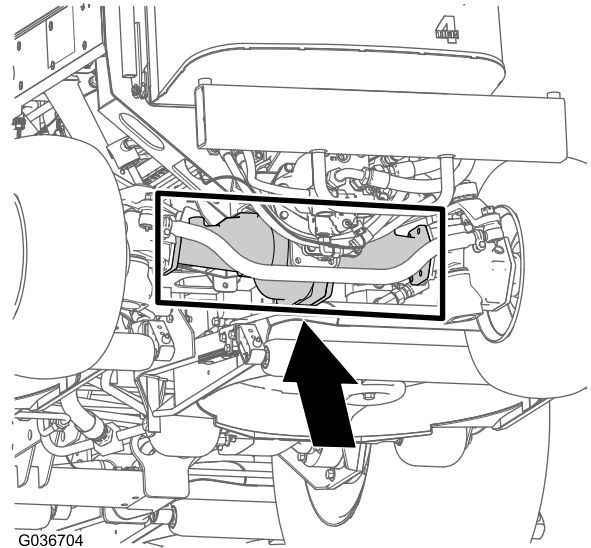

G036704

g036704

Figure 104

## Checking the Rear-Axle Lubricant

**Service Interval:** Every 400 hours

The rear axle is filled with SAE 85W-140 gear lube. The capacity is 2.4 L (80 fl oz). Visually inspect for leaks daily.

1. Park the machine on a level surface, engage the parking brake, lower the mower decks, shut off the engine, and remove the key.
2. Remove a check plug from 1 end of the axle and ensure that the lubricant is up to the bottom of the hole (Figure 105).

**Note:** If the level is low, remove the fill plug and add enough lubricant to bring the level up to the bottom of the check-plug holes.

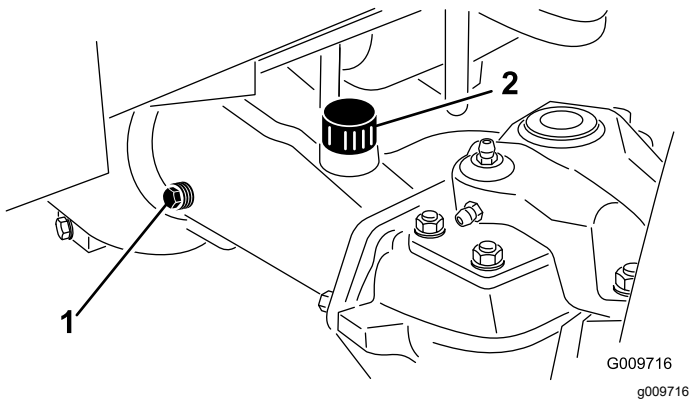

**Figure 105**

1. Check plug
2. Fill plug

## Changing the Rear-Axle Lubricant

**Service Interval:** After the first 200 hours  
Every 800 hours

**Lubricant specification:** high-quality SAE 85W-140 gear lubricant

**Axle capacity:** 2.4 L (80 fl oz)

1. Park the machine on a level surface, engage the parking brake, lower the mower decks, shut off the engine, and remove the key.
2. Clean the area around the 3 drain plugs—1 on each end and 1 in the center ([Figure 106](#)).

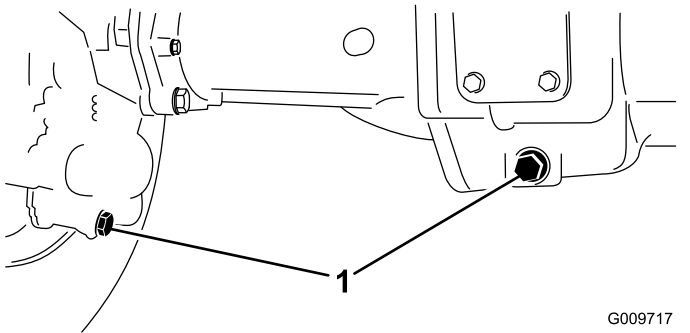

**Figure 106**

1. Drain-plug location

3. Remove the oil-level check plugs and the main-axle-vent cap to ease draining the gear lubricant.
4. Remove the drain plugs and allow the gear lubricant to drain into the pans.
5. Install the plugs.
6. Remove a check plug and fill the axle with approximately 2.4 L (80 fl oz) of 85W-140 gear

lube or until the lubricant is up to the bottom of the hole.

7. Install the check plug.

## Checking the Rear-Axle-Gearbox Lubricant

**Service Interval:** Every 400 hours

The gear box is filled with SAE 85W-140 gear lube. The capacity is 0.5 L (16 fl oz). Visually inspect for leaks daily.

1. Park the machine on a level surface, engage the parking brake, lower the mower decks, shut off the engine, and remove the key.
2. Remove the check/fill plug from the left side of the gear box and ensure that lubricant is up to the bottom of the hole ([Figure 107](#)).

**Note:** If the level is low, add enough lubricant to bring the level up to the bottom of the hole.

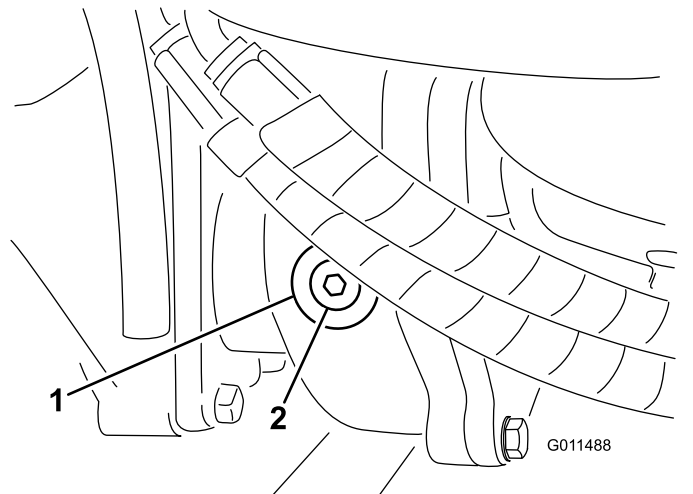

**Figure 107**

1. Gearbox
2. Check/fill plug

# Checking the Rear Wheel Toe-In

**Service Interval:** Every 800 hours/Yearly (whichever comes first)

1. Park the machine on a level surface, engage the parking brake, lower the mower decks, shut off the engine, and remove the key.
2. Measure the center-to-center distance (at axle height) at the front and rear of the steering tires (Figure 108).

**Note:** The front measurement must be 3 mm (1/8 inch) less than the rear measurement.

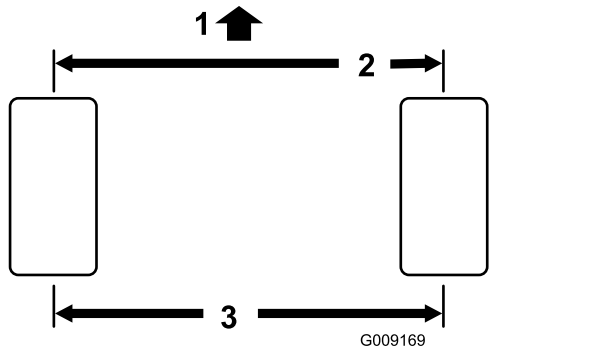

**Figure 108**

1. Front of the machine
2. 3 mm (1/8 inch) less than the rear measurement
3. Center to center distance

3. To adjust, remove the cotter pin and nut from either tie rod ball joint (Figure 109). Remove the tie-rod ball joint from the axle-case support.

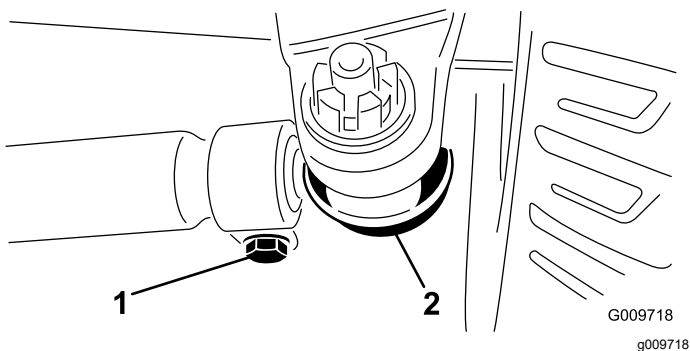

**Figure 109**

1. Tie-rod clamp
2. Tie-rod ball joint

4. Loosen the clamps at both ends of the tie rods (Figure 109).
5. Rotate the detached ball joint inward or outward 1 complete revolution and tighten the clamp at the loose end of the tie rod.
6. Rotate the entire tie-rod assembly the same direction (inward or outward) 1 complete

revolution and tighten the clamp at the connected end of the tie rod.

7. Install the ball joint in the axle-case support, tighten the nut finger-tight, and measure the toe-in.
8. Repeat procedure if necessary.
9. Tighten the nut and install a new cotter pin when the adjustment is correct.

# Cooling System Maintenance

## Cooling System Safety

- Swallowing engine coolant can cause poisoning; keep out of reach from children and pets.
- Discharge of hot, pressurized coolant or touching a hot radiator and surrounding parts can cause severe burns.
  - Always allow the engine to cool at least 15 minutes before removing the radiator cap.
  - Use a rag when opening the radiator cap, and open the cap slowly to allow steam to escape.
- Do not operate the machine without the covers in place.
- Keep your fingers, hands and clothing clear of rotating fan and drive belt.
- Shut off the engine and remove the key before performing maintenance.

## Checking the Cooling System

**Service Interval:** Before each use or daily

**Coolant specification:** 50/50 mixture of water and ethylene glycol antifreeze

**Cooling system capacity:** 8.5 L (9 US qt).

1. Park the machine on a level surface, engage the parking brake, lower the mower decks, shut off the engine, and remove the key.
2. Carefully remove the radiator cap.

### **⚠ CAUTION**

**If the engine has been running, the pressurized, hot coolant can escape and cause burns.**

- Do not open the radiator cap when the engine is running.
- Use a rag when opening the radiator cap, and open the cap slowly to allow steam to escape.

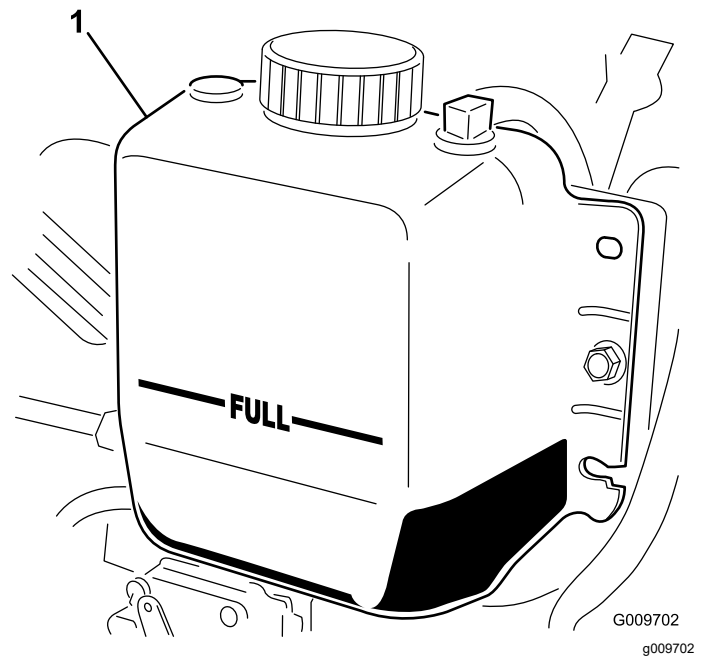

**Figure 110**

1. Expansion tank

3. Check the coolant level in the radiator. The radiator should be filled to the top of the filler neck and the expansion tank filled to the FULL mark (Figure 110).
4. If the coolant is low, add a 50/50 mixture of water and ethylene glycol anti-freeze. Do not use water only or alcohol/methanol based coolants.
5. Install the radiator cap and expansion-tank cap.

# Cleaning the Cooling System

**Service Interval:** Before each use or daily—Remove debris from the engine area, oil cooler, and radiator (clean them more frequently in dirty conditions).

This machine is equipped with a hydraulically driven fan drive system that automatically (or manually) reverses to reduce oil cooler/radiator and screen debris buildup. While this feature can help reduce the time required to clean oil cooler/radiator, it does not eliminate the need for routine cleaning. Periodic cleaning and inspection of the radiator/cooler is still required.

1. Park the machine on a level surface, engage the parking brake, lower the mower decks, shut off the engine, and remove the key.

2. Unlatch and swing open the rear screen (Figure 111).

**Note:** To remove the screen, lift it off the hinge pins.

3. Clean the screen thoroughly of all debris.

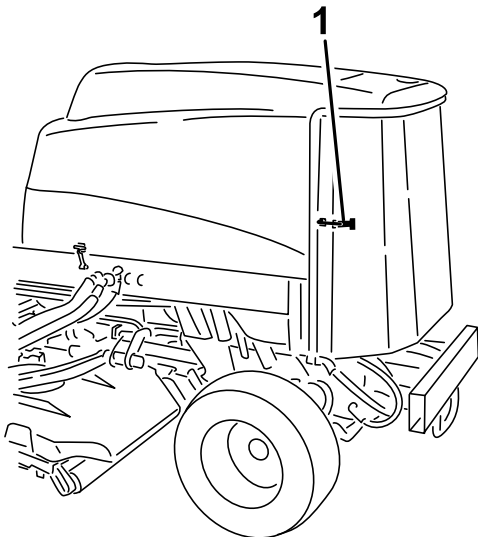

**Figure 111**

g198662

1. Rear-screen latch

4. Thoroughly clean both sides of the oil cooler and the radiator with compressed air (Figure 112).

**Note:** Start from the front and blow the debris out toward the back. Then clean from the back side and blow toward the front. Repeat procedure several times until you remove all chaff and debris.

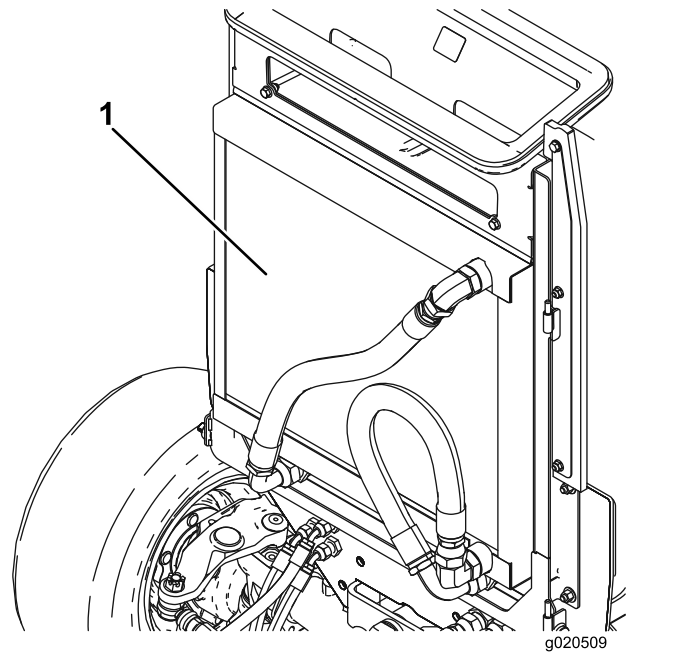

g020509

g020509

**Figure 112**

1. Oil cooler/radiator

**Important:** Cleaning the oil cooler/radiator with water promotes premature corrosion damage to components and compacts debris.

5. Close the rear screen and secure it with the latch.

# Brake Maintenance

## Adjusting the Service Brakes

Adjust the service brakes when there is more than 25 mm (1 inch) of free travel of the brake pedal, or when the brakes do not work effectively. Free travel is the distance the brake pedal moves before you feel braking resistance.

1. Park the machine on a level surface, engage the parking brake, lower the mower decks, shut off the engine, and remove the key.
2. Release the locking latch from the brake pedals so that both pedals work independently of each other.
3. To reduce free travel of the brake pedals, tighten the brakes as follows:
  - A. Loosen the front nut on the threaded end of the brake cable (Figure 113).

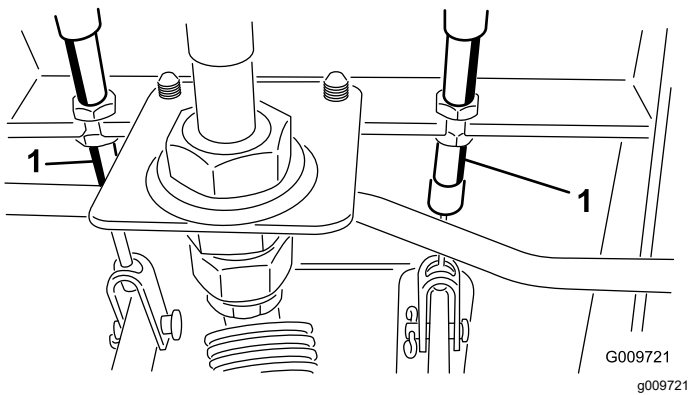

Figure 113

1. Brake cable

- B. Tighten the rear nut to move the cable rearward until the brake pedals have 13 to 25 mm (1/2 to 1 inch) of free travel.
- C. Tighten the front nuts after the brakes are adjusted correctly.

# Belt Maintenance

## Servicing the Alternator Belt

**Service Interval:** Every 100 hours

Proper tension of the belt allows 10 mm (3/8 inch) of deflection when a force of 4.5 kg (10 lb) is applied on the belt midway between the pulleys.

If the deflection is not 10 mm (3/8 inch), loosen the alternator-mounting bolts (Figure 114).

**Note:** Increase or decrease the alternator-belt tension and tighten the bolts. Check the deflection of the belt again to ensure that the tension is correct.

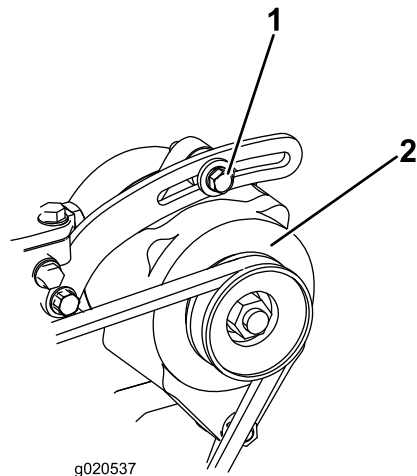

Figure 114

1. Mounting bolt
2. Alternator



# Hydraulic System Maintenance

## Hydraulic System Safety

- Seek immediate medical attention if fluid is injected into skin. Injected fluid must be surgically removed within a few hours by a doctor.
- Ensure that all hydraulic-fluid hoses and lines are in good condition and all hydraulic connections and fittings are tight before applying pressure to the hydraulic system.
- Keep your body and hands away from pinhole leaks or nozzles that eject high-pressure hydraulic fluid.
- Use cardboard or paper to find hydraulic leaks.
- Safely relieve all pressure in the hydraulic system before performing any work on the hydraulic system.

## Checking the Hydraulic-Fluid Level

**Service Interval:** Before each use or daily

The reservoir is filled at the factory with approximately 28.4 L (7.50 US gallons) of high-quality hydraulic fluid. Check the level of the hydraulic fluid before the engine is first started and daily thereafter. The recommended replacement fluid is as follows:

**Toro Premium All Season Hydraulic Fluid** (Available in 19 L (5 US gallon) pails or 208 L (55 US gallon) drums. See the *Parts Catalog* or your authorized Toro distributor for part numbers).

Alternative fluids: If the Toro fluid is not available, other **conventional, petroleum-based** fluids may be used, provided they meet all the following material properties and industry specifications. Check with your oil supplier to see whether the oil meets these specifications.

**Note:** Toro does not assume responsibility for damage caused by improper substitutions, so use only products from reputable manufacturers who will stand behind their recommendation.

## High Viscosity Index/Low Pour Point Anti-Wear Hydraulic Fluid, ISO VG 46

### Material Properties:

Viscosity, ASTM D445	cSt @ 40°C (104°F) 44 to 50 cSt @ 100°C (212°F) 7.9 to 9.1
Viscosity Index ASTM D2270	140 to 160
Pour Point, ASTM D97	-37°C to -45°C (-34°F to -49°F)

### Industry Specifications:

Vickers I-286-S (Quality Level), Vickers M-2950-S (Quality Level), Denison HF-0

**Important:** The ISO VG 46 Multigrade fluid has been found to offer optimal performance in a wide range of temperature conditions. For operation in consistently high ambient temperatures, 65°F (18°C) to 120°F (49°C), ISO VG 68 hydraulic fluid may offer improved performance.

## Premium Biodegradable Hydraulic Fluid-Mobil EAL EnviroSyn 46H

**Important:** Mobil EAL EnviroSyn 46H is the only synthetic biodegradable fluid approved by Toro. This fluid is compatible with the elastomers used in Toro hydraulic systems and is suitable for a wide-range of temperature conditions. This fluid is compatible with conventional mineral oils, but for maximum biodegradability and performance the hydraulic system should be thoroughly flushed of conventional fluid. The fluid is available in 19 L (5 US gallon) containers or 208 L (55 US gallon) drums from your Mobil Distributor.

**Important:** Many hydraulic fluids are almost colorless, making it difficult to spot leaks. A red dye additive for the hydraulic system fluid is available in 20 ml (0.67 oz) bottles. A bottle is sufficient for 15 to 22 L (4 to 6 US gallons) of hydraulic fluid. Order Part No. 44-2500 from your authorized Toro distributor.

1. Park the machine on a level surface, engage the parking brake, lower the cutting units, shut off the engine, and remove the key.
2. Check the hydraulic-fluid level ([Figure 115](#)).

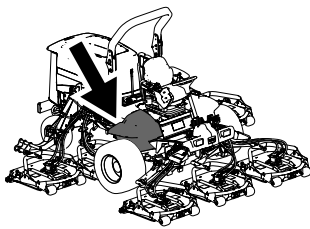

# Changing the Hydraulic Fluid

**Service Interval:** Every 800 hours

If the fluid becomes contaminated, contact your authorized Toro distributor, because the system must be flushed. Contaminated fluid looks milky or black when compared to clean oil.

g198718

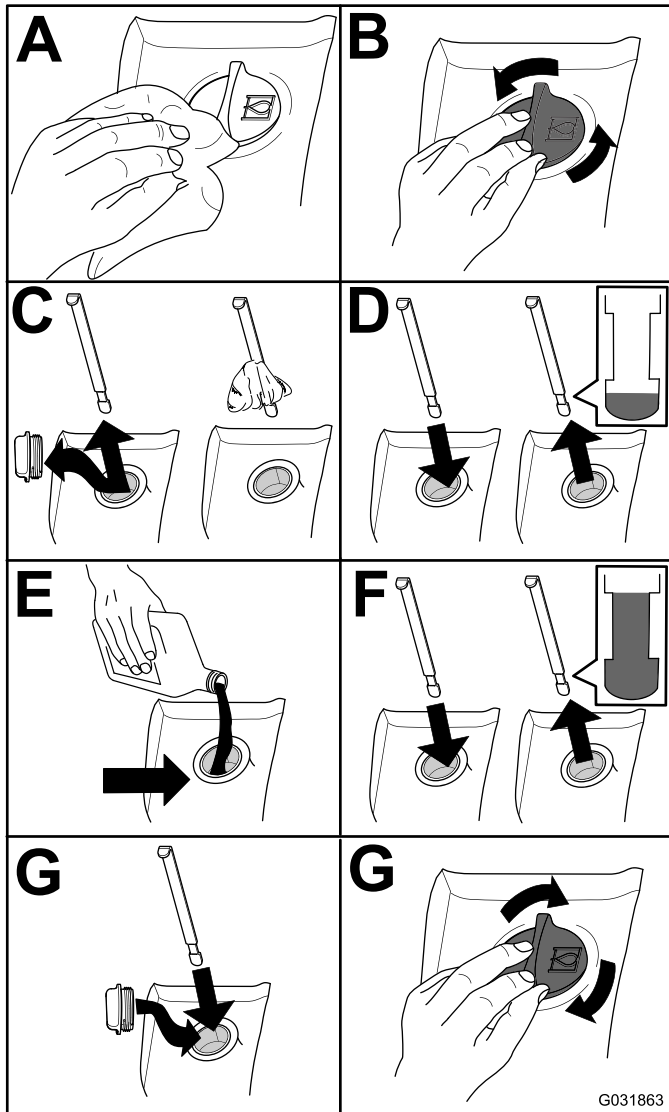

G031863

g031863

**Figure 115**

1. Park the machine on a level surface, engage the parking brake, lower the cutting units, shut off the engine, and remove the key.
2. Raise the hood.
3. Disconnect the case return line from the bottom of the reservoir and let the hydraulic fluid flow into a large drain pan.
4. Install the hose when the hydraulic fluid stops draining.
5. Fill the reservoir with hydraulic fluid; refer to [Checking the Hydraulic-Fluid Level \(page 73\)](#).

**Important:** Use only the hydraulic fluids specified. Other fluids could cause system damage.

6. Install the reservoir cap.
7. Turn the key in the key switch to the ON position to start the engine. Use all the hydraulic controls to distribute hydraulic fluid throughout the system, and check for leaks.
8. Turn the key in the key switch to the OFF position.
9. Check the fluid level and add enough to raise level the level to the FULL mark on the dipstick. **Do not overfill.**

# Replacing the Hydraulic Filters

**Service Interval:** After the first 200 hours

Every 800 hours

Use Toro replacement filters Part No. 94-2621 for the rear (cutting units) of the machine and Part No. 75-1310 for the front (charge) of the machine.

**Important:** Using another filter may void the warranty on some components.

1. Tilt the operator's seat to access the mower-pressure filter; refer to [Accessing the Hydraulic Lift Compartment](#) (page 55)

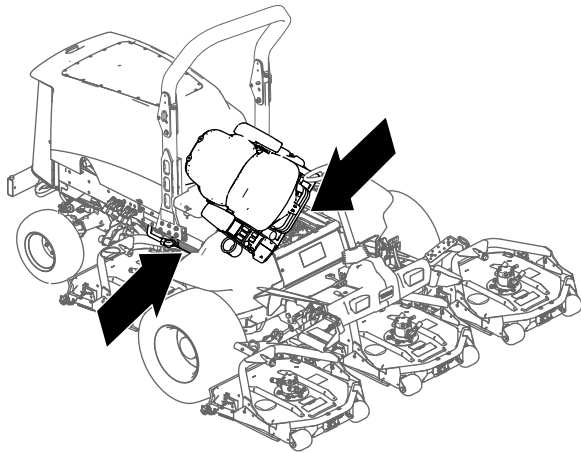
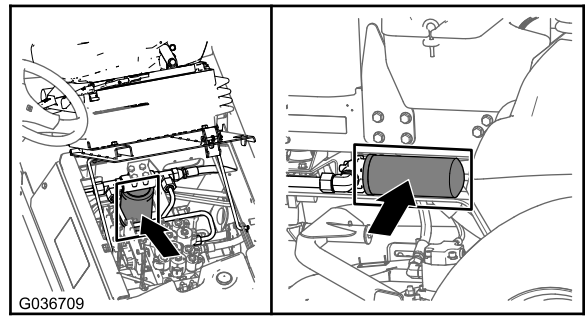

Figure 116

g201858

2. Replace the charge hydraulic filter at the hydraulic lift compartment as shown in [Figure 117](#).



g036709

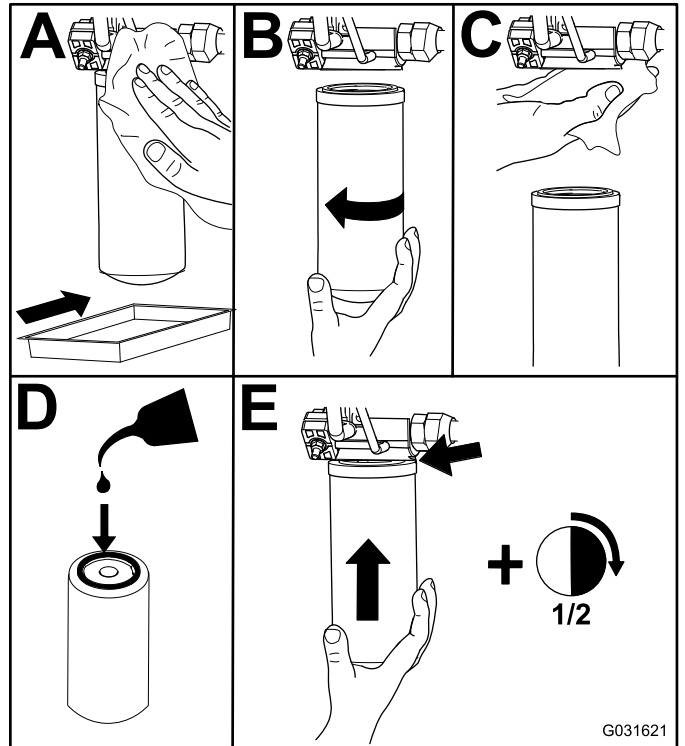

Figure 117

g031621

3. Lower and secure the operator's seat.
4. Replace the return filter at the right side of the machine ([Figure 117](#)).
5. Start the engine and let it run for about 2 minutes to purge air from the system. Shut off the engine and check for leaks.

## Checking the Hydraulic Lines and Hoses

**Service Interval:** Before each use or daily

Every 2 years

Inspect the hydraulic lines and hoses daily for leaks, kinked lines, loose mounting supports, wear, loose fittings, weather deterioration, and chemical deterioration. Make all necessary repairs before operating the machine.

# Cutting Unit Maintenance

## Removing the Cutting Units

1. Park the machine on a level surface, engage the parking brake, lower the cutting units, shut off the engine, and remove the key.
2. Disconnect and remove the hydraulic motor from the cutting unit (Figure 118). Cover the top of the spindle to prevent contamination.

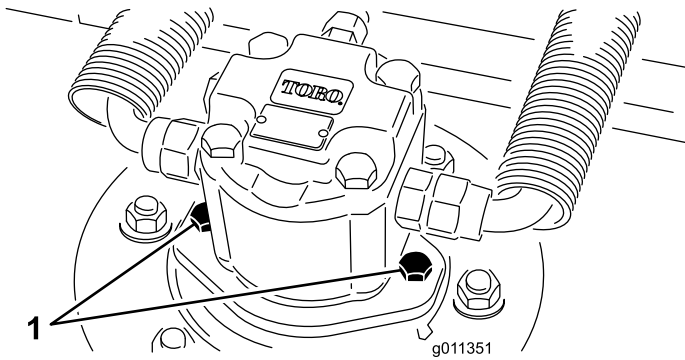

Figure 118

1. Motor-mounting screws

3. Remove the lynch pin (for Groundsmaster 4500 machines) or retaining nut (for Groundsmaster 4700 machines) securing the cutting unit-carrier frame to the lift-arm pivot pin (Figure 119).

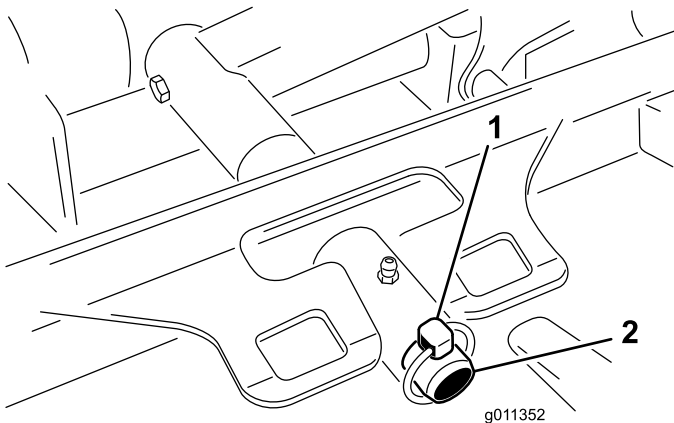

Figure 119

1. Lynch pin
2. Lift-arm pivot pin

4. Roll the cutting unit away from the machine.

## Installing the Cutting Units

1. Move the cutting unit into position in front of the machine.
2. Slide the cutting unit-carrier frame onto the lift-arm-pivot pin (Figure 119). Secure the cutting unit to the pin with the lynch pin (for Groundsmaster 4500 machines) or retaining nut (for Groundsmaster 4700 machines).
3. Install the hydraulic motor to the cutting unit (Figure 118). Make sure that the O-ring is in position and not damaged.
4. Grease the spindle.

## Servicing the Front Roller

Inspect the front roller for wear, excess wobble, or binding. Service or replace the roller or components if any of these conditions exist.

## Disassembling the Front Roller

1. Remove the roller-mounting bolt (Figure 120).
2. Insert a punch through the end of the roller housing and drive the opposite bearing out by alternating taps to the opposite side of inner bearing race. There should be a 1.5 mm (0.060 inch) lip of inner race exposed.

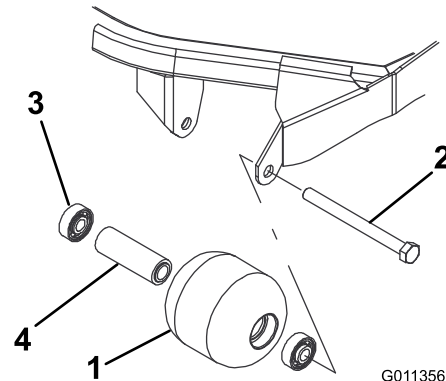

Figure 120

1. Front roller
2. Mounting bolt
3. Bearing
4. Bearing spacer

3. Push the second bearing out in press.
4. Inspect the roller housing, bearings, and bearing spacer for damage (Figure 120). Replace any damaged components and assemble them.

## Assembling the Front Roller

1. Press the first bearing into the roller housing (Figure 120). Press on the outer race only or equally on the inner and outer race.
2. Insert the spacer (Figure 120).
3. Press the second bearing into the roller housing (Figure 120). Pressing equally on the inner and outer race until the inner race contacts the spacer.
4. Install the roller assembly into the cutting-unit frame.
5. Verify that there is no more than a 1.5 mm (0.060 inch) gap between roller assembly and the roller mount brackets of the cutting-unit frame. If there is a gap over 1.5 mm (0.060 inch), install enough 5/8-inch diameter washers to take up the slop.

**Important:** Securing the roller assembly with a gap larger than 1.5 mm (0.060 inch) creates a side load on the bearing and can lead to premature bearing failure

6. Torque the mounting bolt to 108 N·m (80 ft-lb).

## Blade Maintenance

### Blade Safety

A worn or damaged blade can break, and a piece of the blade could be thrown toward you or bystanders, resulting in serious personal injury or death.

- Inspect the blade periodically for wear or damage.
- Use care when checking the blades. Wrap the blades or wear gloves, and use caution when servicing the blades. Only replace or sharpen the blades; never straighten or weld them.
- On multi-bladed machines, take care as rotating 1 blade can cause other blades to rotate.

### Servicing the Blade Plane

The cutting unit comes from the factory preset at 5 cm (2 inches) height of cut and blade rake of 7.9 mm (0.310 inch). The left and right heights are also preset to within  $\pm 0.7$  mm (0.030 inch) of the other.

The cutting unit is designed to withstand blade impacts without deformation of the chamber. If the blade strikes a solid object, inspect the blade for damage and the blade plane for accuracy.

### Inspecting the Blade Plane

1. Remove the hydraulic motor from the cutting unit and remove the cutting unit from the machine.
2. Use a hoist (or minimum of 2 people) and place the cutting unit on a flat table.
3. Mark 1 end of the blade with a paint pen or marker. Use this end of the blade to check all heights.
4. Position the cutting edge of the marked end of the blade at 12 o'clock (straight ahead in the direction of mowing) (Figure 121) and measure height from table to cutting edge of blade.

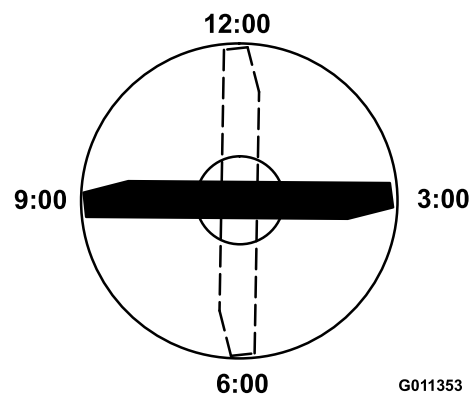

Figure 121

5. Rotate the marked end of the blade to the 3 and 9 o'clock positions (Figure 121) and measure the heights.
6. Compare the 12 o'clock measured height to the height-of-cut setting. It should be within 0.7 mm (0.030 inch). The 3 and 9 o'clock heights should be 1.6 to 6.0 mm (0.060 to 0.240 inch) higher than the 12 o'clock setting and within 2.2 mm (0.090 inch) of each other.

If any of these measurements are not within specification, proceed to [Adjusting the Blade Plane](#) (page 78).

## Adjusting the Blade Plane

Start with the front adjustment (change 1 bracket at a time).

1. Remove the height-of-cut bracket, (front, left, or right) from the cutting-unit frame (Figure 122).
2. Adjust 1.5 mm (0.060 inch) shims and/or 0.7 mm (0.030 inch) shims between the cutting-unit frame and bracket to achieve the desired height setting (Figure 122).

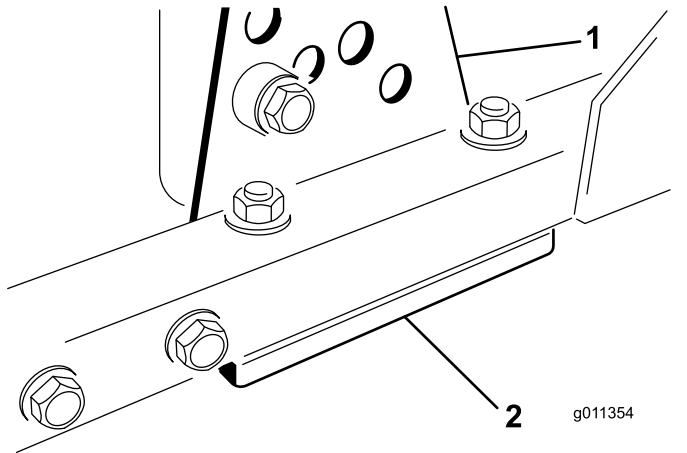

Figure 122

1. Height-of-cut bracket
2. Shims

3. Install the height-of-cut bracket to the cutting-unit frame with the remaining shims assembled below the height-of-cut bracket.
4. Secure the socket-head bolt/spacer and flange nut.

**Note:** Socket-head bolt/spacer are held together with thread-locking adhesive to prevent the spacer from falling inside the cutting-unit frame.

5. Verify the 12 o'clock height and adjust if needed.
6. Determine if only 1 or both (right and left) height-of-cut brackets need to be adjusted.

**Note:** If the 3 or 9 o'clock side is 1.6 to 6.0 mm (0.060 to 0.240 inch) higher than the new front height then no adjustment is needed for that side. Adjust the other side to within  $\pm 2.2$  mm (0.090 inch) of the correct side.

7. Adjust the right and/or left height-of-cut brackets by repeating steps 1 through 4.
8. Secure the carriage bolts and flange nuts.
9. Verify the 12, 3, and 9 o'clock heights.

## Removing and Installing the Cutting-Unit Blade(s)

Replace the blade if it hits a solid object, is out of balance, or is bent. Always use genuine Toro replacement blades to ensure safety and optimum performance.

1. Park the machine on a level surface, raise the cutting unit to the highest position, engage the parking brake, shut off the engine, and remove the key.

**Note:** Block the cutting unit to prevent it from accidentally falling.

2. Grasp the end of the blade using a rag or thickly-padded glove.
3. Remove the blade bolt, anti-scalp cup, and blade from the spindle shaft (Figure 123).

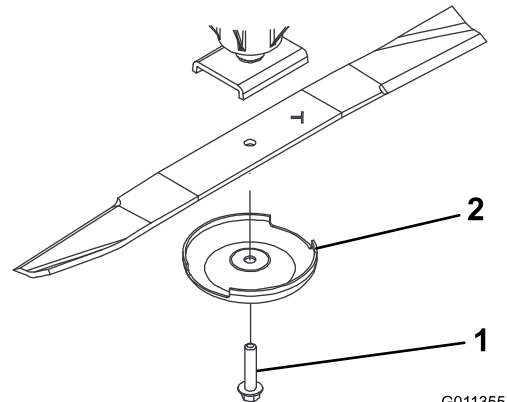

Figure 123

1. Blade bolt
2. Anti-scalp cup

4. Install the blade, anti-scalp cup, and blade bolt and tighten the blade bolt to 115 to 149 N·m (85 to 110 ft·lb).

**Important:** The curved part of the blade must be pointing toward the inside of the cutting unit to ensure proper cutting.

**Note:** After striking a foreign object, torque all spindle-pulley nuts to 115 to 149 N·m (85 to 110 ft·lb).

# Inspecting and Sharpening the Mower Blade(s)

Two areas must be considered when checking and servicing the mower blade—the sail and the cutting edge. Both cutting edges and the sail, which is the turned-up portion opposite of the cutting edge, contribute to a good quality of cut. The sail is important because it lifts the grass up straight, thereby producing an even cut. However, the sail gradually wears down during operation. As the sail wears down, the quality of cut degrades, although the cutting edges are sharp. The cutting edge of the blade must be sharp so that the grass is cut rather than torn. A dull cutting edge is evident when the tips of the grass appear brown and shredded. Sharpen the cutting edges to correct this condition.

1. Park the machine on a level surface, raise the mower deck, engage the parking brake, put the traction pedal in NEUTRAL, put the PTO lever in the OFF position, shut off the engine, and remove the key from the ignition.
2. Examine the cutting ends of the blade carefully, especially where the flat and curved parts of the blade meet (Figure 124).

**Note:** Because sand and abrasive material can wear away the metal that connects the flat and curved parts of the blade, check the blade before using the mower. If wear is noticed (Figure 124), replace the blade.

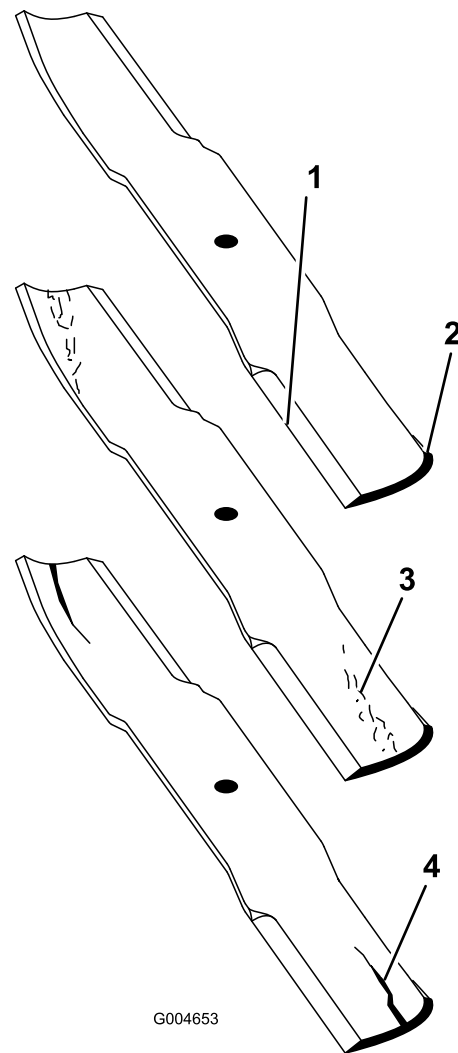

Figure 124

- |                 |                      |
|-----------------|----------------------|
| 1. Cutting edge | 3. Wear/slot forming |
| 2. Curved area  | 4. Crack             |

3. Examine the cutting edges of all of the blades and sharpen the cutting edges if they are dull or nicked (Figure 125).

**Note:** Sharpen only the top of the cutting edge and maintain the original cutting angle to ensure sharpness (Figure 125). The blade remains balanced if you remove the same amount of metal from both cutting edges.

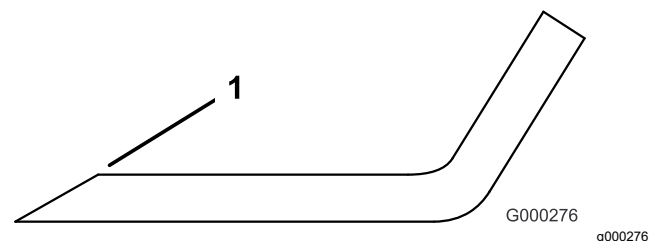

Figure 125

1. Sharpen at the original angle.

**Note:** Remove the blades and sharpen them on a grinder. After sharpening the cutting edges, install the blade with the anti-scalp cup and blade bolt; refer to [Removing and Installing the Cutting-Unit Blade\(s\)](#) (page 78).

# Storage

## Preparing for Seasonal Storage

### Traction Unit

1. Always shut off the engine, and remove the key. Wait for all movement to stop and allow the machine to cool.
2. Thoroughly clean the traction unit, mower decks, and the engine.
3. Check the tire pressure; refer to [Checking the Tire Pressure](#) (page 26).
4. Check all fasteners for looseness; tighten as necessary.
5. Grease or oil all grease fittings and pivot points. Wipe up any excess lubricant.
6. Lightly sand and use touch-up paint on painted areas that are scratched, chipped, or rusted. Repair any dents in the metal body.
7. Service the battery and cables as follows:
  - A. Remove the battery terminals from the battery posts.
  - B. Clean the battery, terminals, and posts with a wire brush and baking soda solution.
  - C. Coat the cable terminals and battery posts with Grafo 112X skin-over grease (Toro Part No. 505-47) or petroleum jelly to prevent corrosion.
  - D. Slowly recharge the battery every 60 days for 24 hours to prevent lead sulfation of the battery.
8. Engage the transport latches (Groundsmaster 4700-D machines only).

### Engine

1. Drain the engine oil from the oil pan and install the drain plug.
2. Remove and discard the oil filter. Install a new oil filter.
3. Fill the oil pan with motor oil.
4. Start the engine and run it at idle speed for approximately 2 minutes.
5. Shut off the engine.
6. Flush the fuel tank with fresh, clean diesel fuel.
7. Secure all fuel system fittings.
8. Thoroughly clean and service the air-cleaner assembly.



9. Seal the air-cleaner inlet and the exhaust outlet with weatherproof tape.
10. Check the anti-freeze protection and add a 50/50 solution of water and ethylene glycol anti-freeze as needed for the expected minimum temperature in your area.

## Mower Deck

If the mower decks are separated from the traction unit for any length of time, install a spindle plug in the top of the spindles to protect the spindles from dust and water.

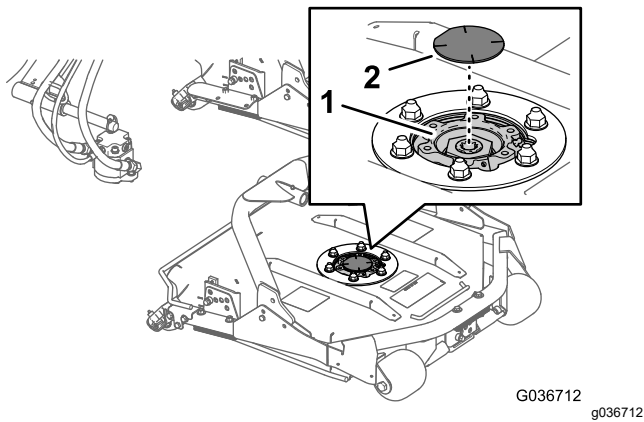

**Figure 126**

1. Spindle plug
2. Spindle sprocket

## EEA/UK Privacy Notice

### **Toro's Use of Your Personal Information**

The Toro Company ("Toro") respects your privacy. When you purchase our products, we may collect certain personal information about you, either directly from you or through your local Toro company or dealer. Toro uses this information to fulfil contractual obligations - such as to register your warranty, process your warranty claim or to contact you in the event of a product recall - and for legitimate business purposes - such as to gauge customer satisfaction, improve our products or provide you with product information which may be of interest. Toro may share your information with our subsidiaries, affiliates, dealers or other business partners in connection these activities. We may also disclose personal information when required by law or in connection with the sale, purchase or merger of a business. We will never sell your personal information to any other company for marketing purposes.

### **Retention of your Personal Information**

Toro will keep your personal information as long as it is relevant for the above purposes and in accordance with legal requirements. For more information about applicable retention periods please contact [legal@toro.com](mailto:legal@toro.com).

### **Toro's Commitment to Security**

Your personal information may be processed in the US or another country which may have less strict data protection laws than your country of residence. Whenever we transfer your information outside of your country of residence, we will take legally required steps to ensure that appropriate safeguards are in place to protect your information and to make sure it is treated securely.

### **Access and Correction**

You may have the right to correct or review your personal data, or object to or restrict the processing of your data. To do so, please contact us by email at [legal@toro.com](mailto:legal@toro.com). If you have concerns about the way in which Toro has handled your information, we encourage you to raise this directly with us. Please note that European residents have the right to complain to your Data Protection Authority.



# The Toro Warranty

## A Two-Year Limited Warranty

### Conditions and Products Covered

The Toro Company and its affiliate, Toro Warranty Company, pursuant to an agreement between them, jointly warrant your Toro Commercial product ("Product") to be free from defects in materials or workmanship for two years or 1500 operational hours\*, whichever occurs first. This warranty is applicable to all products with the exception of Aerators (refer to separate warranty statements for these products). Where a warrantable condition exists, we will repair the Product at no cost to you including diagnostics, labor, parts, and transportation. This warranty begins on the date the Product is delivered to the original retail purchaser.

\* Product equipped with an hour meter.

### Instructions for Obtaining Warranty Service

You are responsible for notifying the Commercial Products Distributor or Authorized Commercial Products Dealer from whom you purchased the Product as soon as you believe a warrantable condition exists. If you need help locating a Commercial Products Distributor or Authorized Dealer, or if you have questions regarding your warranty rights or responsibilities, you may contact us at:

Toro Commercial Products Service Department  
Toro Warranty Company  
8111 Lyndale Avenue South  
Bloomington, MN 55420-1196  
952-888-8801 or 800-952-2740  
E-mail: commercial.warranty@toro.com

### Owner Responsibilities

As the Product owner, you are responsible for required maintenance and adjustments stated in your *Operator's Manual*. Failure to perform required maintenance and adjustments can be grounds for disallowing a warranty claim.

### Items and Conditions Not Covered

Not all product failures or malfunctions that occur during the warranty period are defects in materials or workmanship. This warranty does not cover the following:

- Product failures which result from the use of non-Toro replacement parts, or from installation and use of add-on, or modified non-Toro branded accessories and products. A separate warranty may be provided by the manufacturer of these items.
- Product failures which result from failure to perform recommended maintenance and/or adjustments. Failure to properly maintain your Toro product per the Recommended Maintenance listed in the *Operator's Manual* can result in claims for warranty being denied.
- Product failures which result from operating the Product in an abusive, negligent, or reckless manner.
- Parts subject to consumption through use unless found to be defective. Examples of parts which are consumed, or used up, during normal Product operation include, but are not limited to, brake pads and linings, clutch linings, blades, reels, rollers and bearings (sealed or greasable), bed knives, spark plugs, castor wheels and bearings, tires, filters, belts, and certain sprayer components such as diaphragms, nozzles, and check valves, etc.
- Failures caused by outside influence. Conditions considered to be outside influence include, but are not limited to, weather, storage practices, contamination, use of unapproved fuels, coolants, lubricants, additives, fertilizers, water, or chemicals, etc.
- Failure or performance issues due to the use of fuels (e.g. gasoline, diesel, or biodiesel) that do not conform to their respective industry standards.

### Countries Other than the United States or Canada

Customers who have purchased Toro products exported from the United States or Canada should contact their Toro Distributor (Dealer) to obtain guarantee policies for your country, province, or state. If for any reason you are dissatisfied with your Distributor's service or have difficulty obtaining guarantee information, contact the Toro importer.

- Normal noise, vibration, wear and tear, and deterioration.
- Normal "wear and tear" includes, but is not limited to, damage to seats due to wear or abrasion, worn painted surfaces, scratched decals or windows, etc.

### Parts

Parts scheduled for replacement as required maintenance are warranted for the period of time up to the scheduled replacement time for that part. Parts replaced under this warranty are covered for the duration of the original product warranty and become the property of Toro. Toro will make the final decision whether to repair any existing part or assembly or replace it. Toro may use remanufactured parts for warranty repairs.

### Deep Cycle and Lithium-Ion Battery Warranty:

Deep cycle and Lithium-Ion batteries have a specified total number of kilowatt-hours they can deliver during their lifetime. Operating, recharging, and maintenance techniques can extend or reduce total battery life. As the batteries in this product are consumed, the amount of useful work between charging intervals will slowly decrease until the battery is completely worn out. Replacement of worn out batteries, due to normal consumption, is the responsibility of the product owner. Battery replacement may be required during the normal product warranty period at owner's expense. Note: (Lithium-Ion battery only): A Lithium-Ion battery has a part only prorated warranty beginning year 3 through year 5 based on the time in service and kilowatt hours used. Refer to the *Operator's Manual* for additional information.

### Maintenance is at Owner's Expense

Engine tune-up, lubrication, cleaning and polishing, replacement of filters, coolant, and completing recommended maintenance are some of the normal services Toro products require that are at the owner's expense.

### General Conditions

Repair by an Authorized Toro Distributor or Dealer is your sole remedy under this warranty.

**Neither The Toro Company nor Toro Warranty Company is liable for indirect, incidental or consequential damages in connection with the use of the Toro Products covered by this warranty, including any cost or expense of providing substitute equipment or service during reasonable periods of malfunction or non-use pending completion of repairs under this warranty. Except for the Emissions warranty referenced below, if applicable, there is no other express warranty. All implied warranties of merchantability and fitness for use are limited to the duration of this express warranty.**

Some states do not allow exclusions of incidental or consequential damages, or limitations on how long an implied warranty lasts, so the above exclusions and limitations may not apply to you. This warranty gives you specific legal rights, and you may also have other rights which vary from state to state.

### Note regarding engine warranty:

The Emissions Control System on your Product may be covered by a separate warranty meeting requirements established by the U.S. Environmental Protection Agency (EPA) and/or the California Air Resources Board (CARB). The hour limitations set forth above do not apply to the Emissions Control System Warranty. Refer to the Engine Emission Control Warranty Statement supplied with your product or contained in the engine manufacturer's documentation for details.

# California Proposition 65 Warning Information

## What is this warning?

You may see a product for sale that has a warning label like the following:



**WARNING: Cancer and Reproductive Harm—[www.p65Warnings.ca.gov](http://www.p65Warnings.ca.gov).**

## What is Prop 65?

Prop 65 applies to any company operating in California, selling products in California, or manufacturing products that may be sold in or brought into California. It mandates that the Governor of California maintain and publish a list of chemicals known to cause cancer, birth defects, and/or other reproductive harm. The list, which is updated annually, includes hundreds of chemicals found in many everyday items. The purpose of Prop 65 is to inform the public about exposure to these chemicals.

Prop 65 does not ban the sale of products containing these chemicals but instead requires warnings on any product, product packaging, or literature with the product. Moreover, a Prop 65 warning does not mean that a product is in violation of any product safety standards or requirements. In fact, the California government has clarified that a Prop 65 warning "is not the same as a regulatory decision that a product is 'safe' or 'unsafe.'" Many of these chemicals have been used in everyday products for years without documented harm. For more information, go to <https://oag.ca.gov/prop65/faqs-view-all>.

A Prop 65 warning means that a company has either (1) evaluated the exposure and has concluded that it exceeds the "no significant risk level"; or (2) has chosen to provide a warning based on its understanding about the presence of a listed chemical without attempting to evaluate the exposure.

## Does this law apply everywhere?

Prop 65 warnings are required under California law only. These warnings are seen throughout California in a wide range of settings, including but not limited to restaurants, grocery stores, hotels, schools, and hospitals, and on a wide variety of products. Additionally, some online and mail order retailers provide Prop 65 warnings on their websites or in catalogs.

## How do the California warnings compare to federal limits?

Prop 65 standards are often more stringent than federal and international standards. There are various substances that require a Prop 65 warning at levels that are far lower than federal action limits. For example, the Prop 65 standard for warnings for lead is 0.5 µg/day, which is well below the federal and international standards.

## Why don't all similar products carry the warning?

- Products sold in California require Prop 65 labelling while similar products sold elsewhere do not.
- A company involved in a Prop 65 lawsuit reaching a settlement may be required to use Prop 65 warnings for its products, but other companies making similar products may have no such requirement.
- The enforcement of Prop 65 is inconsistent.
- Companies may elect not to provide warnings because they conclude that they are not required to do so under Prop 65; a lack of warnings for a product does not mean that the product is free of listed chemicals at similar levels.

## Why does Toro include this warning?

Toro has chosen to provide consumers with as much information as possible so that they can make informed decisions about the products they buy and use. Toro provides warnings in certain cases based on its knowledge of the presence of one or more listed chemicals without evaluating the level of exposure, as not all the listed chemicals provide exposure limit requirements. While the exposure from Toro products may be negligible or well within the "no significant risk" range, out of an abundance of caution, Toro has elected to provide the Prop 65 warnings. Moreover, if Toro does not provide these warnings, it could be sued by the State of California or by private parties seeking to enforce Prop 65 and subject to substantial penalties.