



Form No. 3443-298 Rev A

Count on it.

Operator's Manual

Pro Force[®] Debris Blower

Model No. 44553—Serial No. 407000000 and Up



It is a violation of California Public Resource Code Section 4442 or 4443 to use or operate the engine on any forest-covered, brush-covered, or grass-covered land unless the engine is equipped with a spark arrester, as defined in Section 4442, maintained in effective working order or the engine is constructed, equipped, and maintained for the prevention of fire.

The enclosed engine owner's manual is supplied for information regarding the US Environmental Protection Agency (EPA) and the California Emission Control Regulation of emission systems, maintenance, and warranty. Replacements may be ordered through the engine manufacturer.

The DOT tire information is located on the side of each tire. This information gives load and speed ratings. Replacement tires should have the same or better ratings. Ensure that the tires meet or exceed the weight requirements of your machine.

Important: Changing or modifying the machine without the express approval from the party responsible for compliance could void your authority to operate the equipment.

Do not change or modify the machine without the express approval from the party responsible for compliance.

Failure to abide by the safety precautions may result in equipment failure, loss of authority to operate the equipment, and personal injury.

The machine owner and operators must abide by all applicable federal, state, and local laws concerning machine installation and operation. Failure to comply could result in penalties and could void the user's authority to operate the machine.

Electromagnetic Compatibility

Domestic: This device complies with FCC rules Part 15. Operation is subject to the following two conditions: (1) This device may not cause harmful interference and (2) this device must accept any interference that may be received, including interference that may cause undesirable operation.

This equipment generates and uses radio frequency energy and if not installed and used properly, that is, in strict accordance with the manufacturer's instructions, may cause interference to radio and television reception. It has been type tested and found to comply with the limits for a FCC Class B computing device in accordance with the specifications in Subpart J of Part 15 of FCC Rules, which are designed to provide reasonable protection against such interference in a residential installation. However, there is no guarantee that interference will not occur in a particular installation. If this equipment does cause interference to radio or television reception, which can be determined by turning the equipment off and on, the user is encouraged to try to correct the interference by one or more of the following measures: Reorient the receiving antenna, relocate the remote control receiver with respect to the radio/TV antenna or plug the controller into a different outlet so that the controller and radio/TV are on different branch circuits. If necessary, the user should consult the dealer or an experienced radio/television technician for additional suggestions. The user may find the following booklet prepared by the Federal Communications Commission helpful: "How to Identify and Resolve Radio-TV Interference Problems". This booklet is available from the U.S. Government Printing Office, Washington, DC 20402. Stock No. 004-000-00345-4.

FCC ID: W70MRF24J40MDME-BASE,
OA3MRF24J40MA-HANDHELD

IC: 7693A-24J40MDME-BASE, 7693A-24J40MA-HANDHELD

Operation is subject to the following two conditions: (1) this device may not cause interference, and (2) this device must accept any interference, including interference that may cause undesired operation of the device.

⚠ WARNING

CALIFORNIA Proposition 65 Warning

The engine exhaust from this product contains chemicals known to the State of California to cause cancer, birth defects, or other reproductive harm.

Battery posts, terminals, and related accessories contain lead and lead compounds, chemicals known to the State of California to cause cancer and reproductive harm. Wash hands after handling.

Use of this product may cause exposure to chemicals known to the State of California to cause cancer, birth defects, or other reproductive harm.

Introduction

The debris blower is towed behind a ride-on machine that is intended to be used by professional, hired operators in commercial applications. It is primarily designed to use wind power to quickly clear large areas of unwanted debris on well-maintained lawns in parks, golf courses, sports fields, and on commercial grounds. Using this product for purposes other than its intended use could prove dangerous to you and bystanders.

Read this information carefully to learn how to operate and maintain your product properly and to avoid injury and product damage. You are responsible for operating the product properly and safely.

Visit www.Toro.com for product safety and operation training materials, accessory information, help finding a dealer, or to register your product.

Whenever you need service, genuine Toro parts, or additional information, contact an Authorized Service Dealer or Toro Customer Service and have the model and serial numbers of your product ready. [Figure 1](#) identifies the location of the model and serial numbers on the product. Write the numbers in the space provided.

Important: With your mobile device, you can scan the QR code on the serial number plate (if equipped) to access warranty, parts, and other product information.

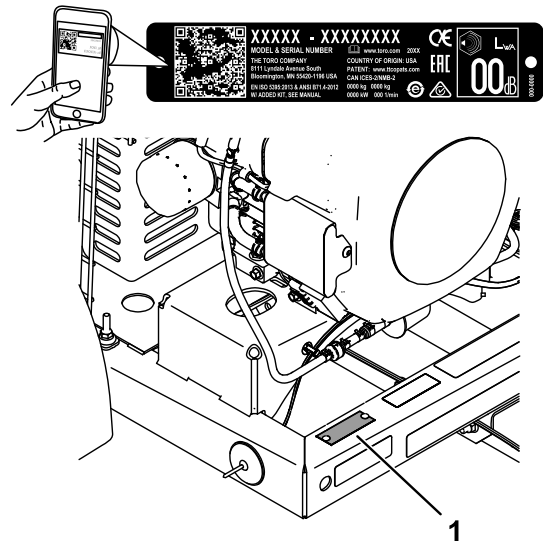

Figure 1

g257159

1. Model and serial number location

Model No. _____
Serial No. _____

This manual identifies potential hazards and has safety messages identified by the safety-alert symbol ([Figure 2](#)), which signals a hazard that may cause serious injury or death if you do not follow the recommended precautions.



Figure 2

Safety-alert symbol

g000502

This manual uses 2 words to highlight information. **Important** calls attention to special mechanical information and **Note** emphasizes general information worthy of special attention.

Contents

Safety	5	Electrical System Maintenance	31
General Safety	5	Electrical System Safety	31
Safety and Instructional Decals	6	Replacing the Fuses	31
Setup	8	Drive System Maintenance	32
1 Connecting the Battery	8	Checking Tire Air Pressure	32
2 Mounting the Hitch to the Machine	9	Torquing the Wheel Lug Nuts	32
3 Connecting the Machine to the Towing Vehicle	9	Inspecting the Tires	32
4 Assembling the Handheld Remote	10	Belt Maintenance	33
Product Overview	11	Adjusting the Nozzle-Control Belt Tension	33
Controls	11	Blower Maintenance	33
Specifications	12	Checking the Blower-Nozzle Clamp.....	33
Radio Specifications	12	Cleaning the Nozzle Guides	34
Attachments/Accessories	12	Handheld Remote Maintenance.....	34
Before Operation	13	Handheld Remote and the Wireless-Control Module	34
Before Operation Safety	13	Replacing the Remote Batteries	36
Attaching the Trailer.....	14	Troubleshooting Fault Codes	37
Adding Fuel	14	Resolving Fault Codes.....	37
Checking the Engine-Oil Level.....	15	Entering Diagnostic Mode and Checking the Codes	38
Performing Daily Maintenance.....	15	Resetting the Fault Codes	38
During Operation	15	Exiting Diagnostic Mode	39
During Operation Safety	15	Cleaning	39
Diagnostic Light.....	16	Washing the Machine	39
Operating the Remote Control	17	Disposing of Waste	39
Starting the Engine	17	Storage	40
Shutting Off the Engine.....	18	Storage Safety.....	40
Using the Remote Control.....	18	Storing the Machine.....	40
Adjusting the Blower Nozzle Direction.....	19		
Operating the Optional Lights	19		
Moving the Machine from the Job Site.....	20		
The Nozzle-Position Gauge.....	20		
Operating Tips	20		
After Operation	21		
After Operation Safety	21		
Hauling the Machine	21		
Connecting the Machine to the Towing Vehicle	21		
Maintenance	22		
Maintenance Safety.....	22		
Recommended Maintenance Schedule(s)	22		
Daily Maintenance Checklist.....	24		
Pre-Maintenance Procedures	24		
Preparing for Maintenance	24		
Preparing the Machine for Weld Repairs	25		
Engine Maintenance	25		
Engine Safety	25		
Servicing the Air Cleaner	25		
Servicing the Carbon Canister	26		
Servicing the Engine Oil.....	27		
Servicing the Spark Plugs.....	29		
Cleaning the Engine Screen and the Oil Cooler	29		
Fuel System Maintenance	30		
Replacing the Fuel Filter	30		
Servicing the Fuel Tank.....	30		

Safety

This machine has been designed in accordance with ANSI standard B71.4-2017.

General Safety

This product is capable of throwing objects. Always follow all safety instructions to avoid serious personal injury.

- Read and understand the contents of both this *Operator's Manual* and the operator's manual of the traction unit before using this machine. Ensure that everyone using this product knows how to use this machine and the traction unit and understands the warnings.
- Use your full attention while operating the machine. Do not engage in any activity that causes distractions; otherwise, injury or property damage may occur.
- Do not put your hands or feet near moving components of the machine.
- Do not operate the machine without all guards and other safety protective devices in place and working on the machine.
- Keep children, bystanders, and pets out of the operating area. Never allow children to operate the machine.
- Shut off the machine, remove the key (if equipped), and wait for all movement to stop before you leave the operator's position. Allow the machine to cool before adjusting, servicing, cleaning, or storing it.

Improperly using or maintaining this machine can result in injury. To reduce the potential for injury, comply with these safety instructions and always pay attention to the safety-alert symbol , which means Caution, Warning, or Danger—personal safety instruction. Failure to comply with these instructions may result in personal injury or death.

Safety and Instructional Decals



Safety decals and instructions are easily visible to the operator and are located near any area of potential danger. Replace any decal that is damaged or missing.



115-5105

decal115-5105

1. Warning—read the *Operator's Manual*.
2. Warning—all operators should read the *Operator's Manual* and be trained before operating the machine.
3. Warning—shut off the engine, remove the key, and read the *Operator's Manual* before performing maintenance.
4. Thrown object hazard—keep bystanders away.
5. Warning—stay away from moving parts; keep all guards and shields in place.
6. Warning—do not start the engine when the machine is disconnected from the tow vehicle; hitch the machine to the tow vehicle before starting the engine.



115-5106

decal115-5106

1. Warning—read the *Operator's Manual*.
2. Thrown object hazard—keep bystanders away.
3. Cutting/dismemberment hazard; hand—stay away from moving parts.

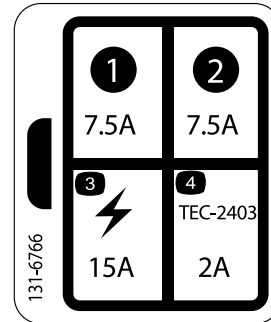

131-6766

decal131-6766

- | | |
|----------|--------------------------------|
| 1. 7.5 A | 3. Electrical accessory (15 A) |
| 2. 7.5 A | 4. TEC-2403 (2 A) |

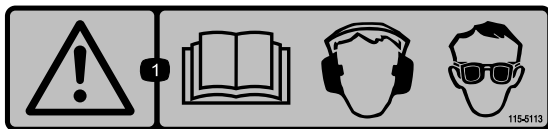

115-5113

decal115-5113

1. Warning—read the *Operator's Manual*; wear hearing and eye protection.



133-8062

decal133-8062

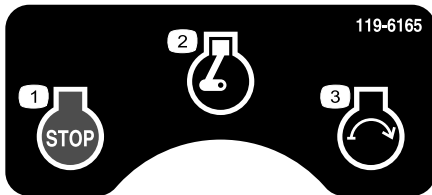

119-6165

decal119-6165

- | | |
|----------------|-----------------|
| 1. Engine—Stop | 3. Engine—Start |
| 2. Engine—Run | |

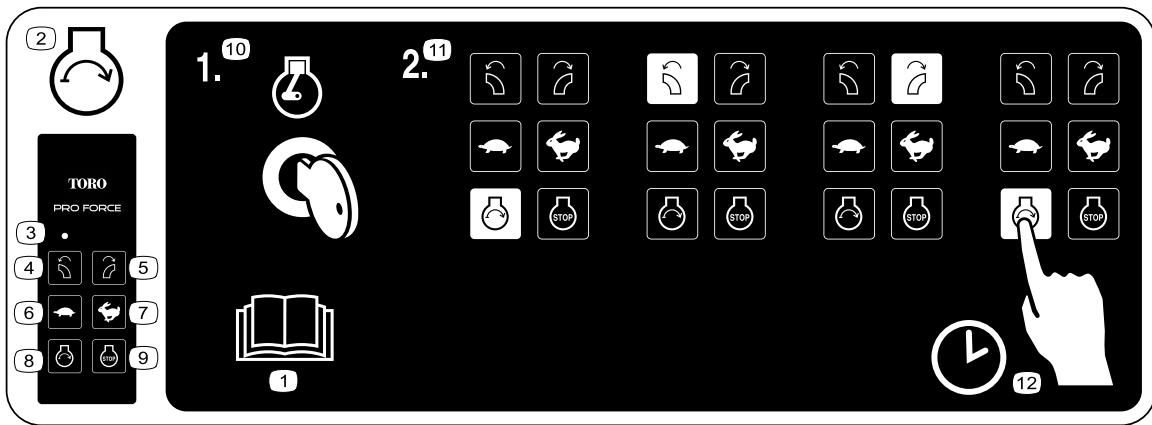

140-6843

decal140-6843

1. Read the *Operator's Manual*.
2. Engine—start
3. LED light
4. Rotate the nozzle to the left
5. Rotate the nozzle to the right
6. Slow
7. Fast
8. Engine—start
9. Engine—stop
10. Engine—run
11. Start engine sequence; Press the start button on the handheld remote; Press the rotate nozzle left button; Press the rotate nozzle right button; Press the engine start button.
12. There is a time limit of 3 seconds between pressing each button.

Setup

Loose Parts

Use the chart below to verify that all parts have been shipped.

Procedure	Description	Qty.	Use
1	Grafo 112X grease (Toro Part No. 505-47)	—	Connect the battery.
2	Machine assembly Hitch Bolt (3/8 x 3 inches) Flange nut (3/8 inch)	1 1 2 2	Mount the hitch to the machine.
3	No parts required	—	Connect the machine to the towing vehicle.
4	Handheld remote AAA batteries Small screws	1 4 6	Assemble the handheld remote.

Media and Additional Parts

Description	Qty.	Use
Operator's Manual	1	Read before operating.
Engine owner's manual	1	Use to reference the engine operation and maintenance.
Remote control	1	Use to remotely operate the blower.

Note: Determine the left and right sides of the machine from the normal operating position.

1

Connecting the Battery

Parts needed for this procedure:

—	Grafo 112X grease (Toro Part No. 505-47)
---	--

Procedure

1. Remove the clips securing the battery cover to the battery box ([Figure 3](#)).

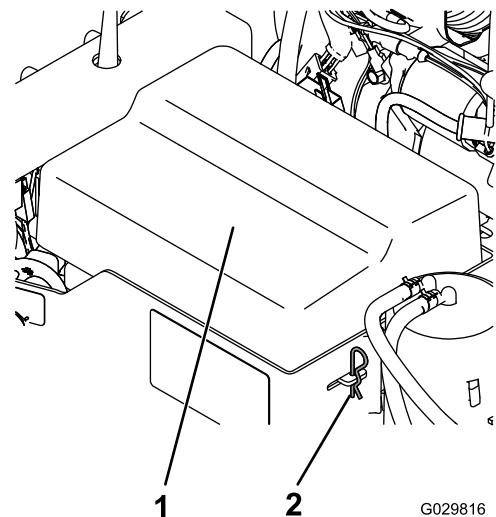

Figure 3

1. Battery cover

2. Battery clip

G029816

g029816

⚠ DANGER

Battery electrolyte contains sulfuric acid, which is fatal if consumed and causes severe burns.

- Do not drink electrolyte and avoid contact with skin, eyes or clothing. Wear eye protection and rubber gloves.
- Fill the battery where clean water is always available for flushing the skin.

2. Attach the positive cable (red cable) to the positive (+) terminal.
3. Attach the negative cable (black cable) to the negative (-) terminal of the battery.
4. Coat the terminals and mounting fasteners with Grafo 112X (skin over) grease (Toro Part No. 505-47) to prevent corrosion.
5. Install the battery cover and secure with the clips.

2

Mounting the Hitch to the Machine

Parts needed for this procedure:

1	Machine assembly
1	Hitch
2	Bolt (3/8 x 3 inches)
2	Flange nut (3/8 inch)

Procedure

1. Position the machine on a flat, level surface.
2. Insert the hitch tube into the frame brackets (Figure 4). Secure the tube to the frame with 2 bolts (3/8 x 3 inches) and flange nuts (3/8 inch).

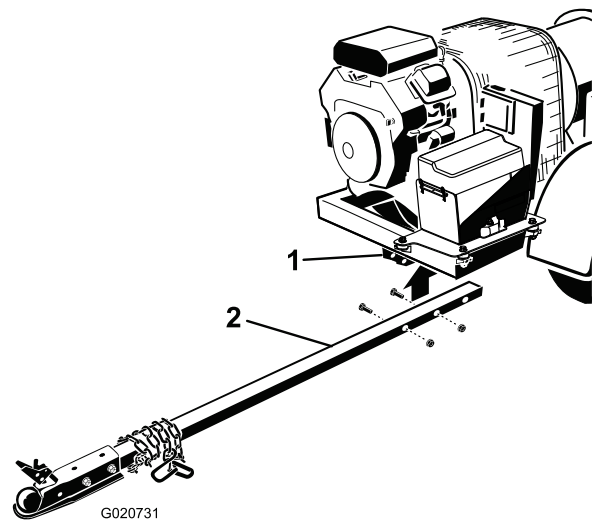

Figure 4

1. Frame brackets
2. Hitch tube

3. Route the wire harness along the right side of the hitch tube (Figure 5).

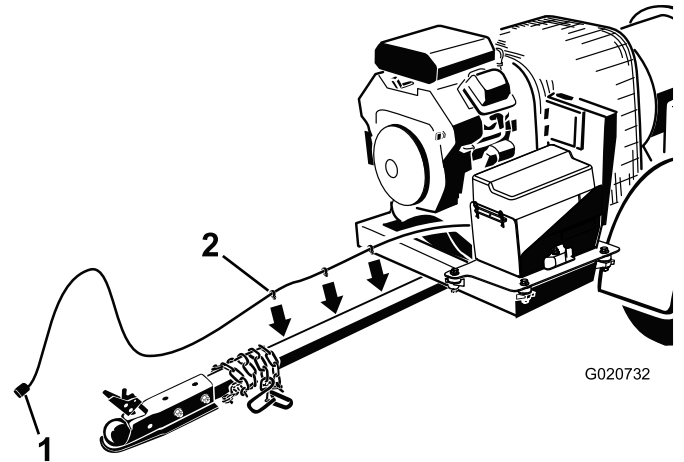

Figure 5

1. Wire harness
2. Harness clips

4. Plug the harness clips into the holes in the side of the hitch tube to secure it (Figure 5).
5. Store the harness connector in the hitch tube holster (Figure 6).

3

Connecting the Machine to the Towing Vehicle

No Parts Required

Procedure

This trailer uses a coupler that requires a 2-inch ball for the hitch.

1. Raise the trailer to a suitable height for your hitch.
2. Lift the coupler lever on the tongue while lowering the cover over the ball hitch (Figure 6).

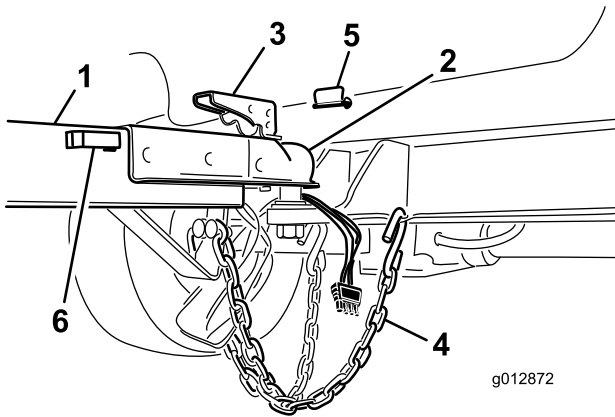

Figure 6

- | | |
|----------------------------------|-----------------------|
| 1. Tongue | 4. Safety chains |
| 2. Ball socket | 5. Locking pin |
| 3. Coupler lever—locked position | 6. Hitch tube holster |

3. Close the coupler lever making sure it is securely locked.
4. Install the locking pin to lock the coupler lever (Figure 6).
5. Cross the safety chains and attach them to the holes on the hitch (Figure 6).
6. Plug the machine wire-harness connector to the towing vehicle connector. Ensure that the brake lights illuminate properly with the brake pedal applied and the taillights flash when the turning signals are use.

4

Assembling the Handheld Remote

Parts needed for this procedure:

1	Handheld remote
4	AAA batteries
6	Small screws

Procedure

1. Remove the rubber bands securing the remote halves together, and remove the back cover.
2. Plug each battery into a terminal cradle, observing proper polarity (Figure 7).

Note: If you install the batteries improperly, the remote will not be damaged, but it will fail to operate. The cradle is embossed with polarity markings for each terminal.

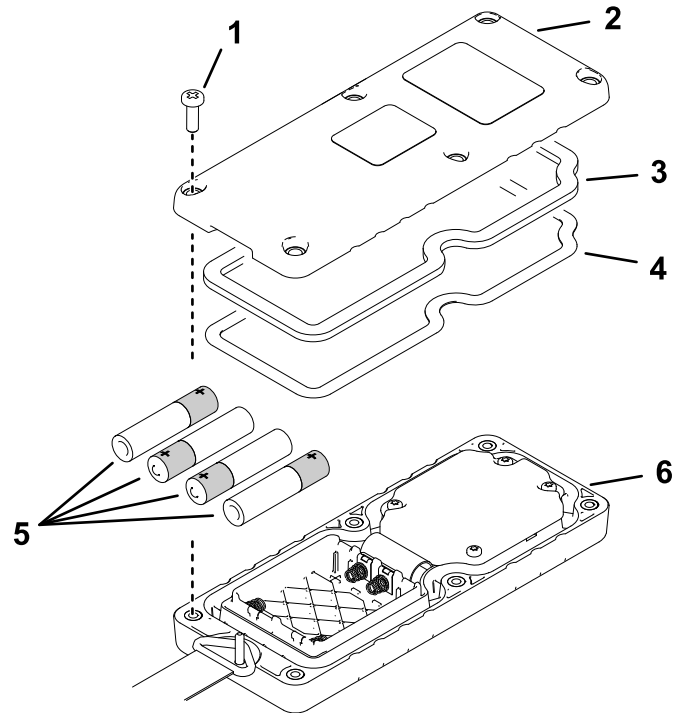

Figure 7

- | | |
|----------|--------------------|
| 1. Screw | 4. Steel gasket |
| 2. Cover | 5. Batteries |
| 3. Seal | 6. Handheld remote |

3. Ensure that the steel gasket and rubber seal are seated in the channel in the remote and set the back cover in place (Figure 7).

- Secure the cover with 6 screws (Figure 7) and torque them to 1.5 to 1.7 N·m (13 to 15 in-lb).

Product Overview

Controls

Engine Stop

Press the ENGINE STOP button to shut off the engine (Figure 8).

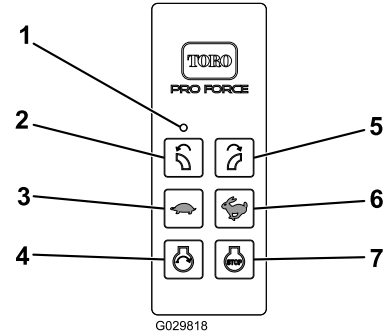

Figure 8

g029818

- | | |
|--------------------------|--------------------------|
| 1. LED light | 5. Rotate right |
| 2. Rotate left | 6. Increase engine speed |
| 3. Decrease engine speed | 7. Engine stop |
| 4. Engine start | |

Engine Start

After completing the starting sequence, press the ENGINE START button to start the engine (Figure 8). Refer to [Starting the Engine \(page 17\)](#) for the starting sequence.

Blower Nozzle Direction

Press the right or left button to rotate the blower nozzle to the desired direction (Figure 8).

Engine Speed

Press the INCREASE ENGINE SPEED (rabbit) or DECREASE ENGINE SPEED (turtle) button to increase or decrease the speed of the engine (Figure 8). Pressing the INCREASE ENGINE SPEED and DECREASE ENGINE SPEED buttons at the same time returns the engine to idle.

Ignition Switch

The ignition switch (Figure 9), which is used to start and shut off the engine, has three positions: OFF, RUN and START. Rotate the key clockwise to START to engage the starter motor. Release the key when the engine starts. The key moves automatically to the RUN position. To shut off the engine, rotate the key counterclockwise to the OFF position.

Choke Control

To start a cold engine, move the choke control lever (Figure 9) to the ON position.

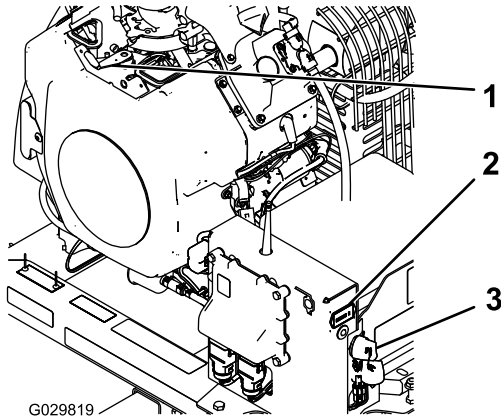

Figure 9

1. Choke control
2. Hour meter
3. Ignition switch

Hour Meter

The hour meter (Figure 9) indicates the total hours of machine operation.

Diagnostic Light

The diagnostic light (Figure 10) is located below the hour meter and indicates machine fault codes. After you turn the key to the RUN position, the diagnostic light will illuminate for 5 seconds, turn off for 5 seconds, and then begin flashing 3 times a second until you push a button on the handheld remote. If the light turns on for 5 seconds and then starts blinking 10 times a second (with or without a 5 second pause) there is a fault with the machine; refer to [Resolving Fault Codes](#) (page 37).

Note: If you have a button pressed on the handheld remote when you start the machine, the light will not flash 3 times a second after it turns off for 5 seconds.

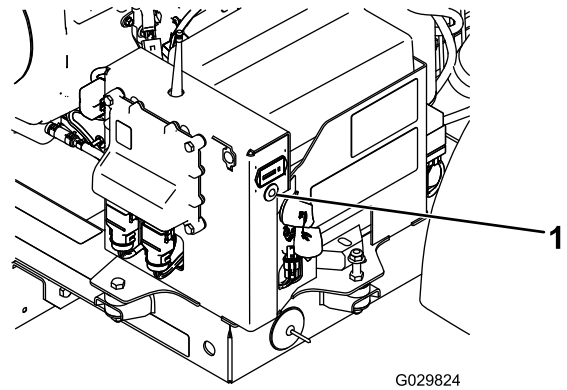

Figure 10

1. Diagnostic light

Specifications

Radio Specifications

Frequency	2.4 GHz
Max output power	19.59 dBm

Attachments/Accessories

A selection of Toro approved attachments and accessories is available for use with the machine to enhance and expand its capabilities. Contact your Authorized Service Dealer or authorized Toro distributor or go to www.Toro.com for a list of all approved attachments and accessories.

To ensure optimum performance and continued safety certification of the machine, use only genuine Toro replacement parts and accessories. Replacement parts and accessories made by other manufacturers could be dangerous, and such use could void the product warranty.

Operation

Note: Determine the left and right sides of the machine from the normal operating position.

Before Operation

Before Operation Safety

General Safety

- Never allow children or untrained people to operate or service the machine. Local regulations may restrict the age of the operator. The owner is responsible for training all operators and mechanics.
 - Become familiar with the safe operation of the equipment, operator controls, and safety signs.
 - Always shut off the engine, remove the key, wait for all moving parts to stop, and allow the machine to cool before adjusting, repairing, cleaning, or storing the machine. Know how to stop the machine and shut off the engine quickly.
 - Keep all guards, safety devices, and decals in place. Repair or replace all safety devices and replace all illegible or missing decals. Do not operate the machine unless they are present and functioning properly.
 - Ensure that the traction unit is suitable for use with an implement of this weight by checking with the traction unit supplier or manufacturer.
 - Do not modify this equipment in any manner.
- containers on the ground, away from your vehicle before filling.
 - Remove the equipment from the truck or trailer and refuel it while it is on the ground. If this is not possible, then refuel from a portable container rather than a fuel-dispenser nozzle.
 - Do not operate the machine without the entire exhaust system in place and in proper working condition.
 - Keep the fuel-dispenser nozzle in contact with the rim of the fuel tank or container opening at all times until fueling is complete. Do not use a nozzle lock-open device.
 - If you spill fuel on your clothing, change your clothing immediately. Wipe up any fuel that spills.
 - Never overfill the fuel tank. Replace the fuel cap and tighten it securely.
 - Store fuel in an approved container and keep it out of the reach of children. Never buy more than a 30-day supply of fuel.
 - Do not fill the fuel tank completely full. Add fuel to the fuel tank until the level is 6 to 13 mm (1/4 to 1/2 inch) below the bottom of the filler neck. This empty space in the tank allows fuel to expand.
 - Avoid prolonged breathing of vapors.
 - Keep your face away from the nozzle and gas tank opening.
 - Avoid contact with skin; wash off spills with soap and water.

Fuel Safety

- Use extreme care in handling fuel. It is flammable and its vapors are explosive.
- Extinguish all cigarettes, cigars, pipes, and other sources of ignition.
- Use only an approved fuel container.
- Do not remove the fuel cap or fill the fuel tank while the engine is running or hot.
- Do not add or drain fuel in an enclosed space.
- Do not store the machine or fuel container where there is an open flame, spark, or pilot light, such as on a water heater or other appliance.
- If you spill fuel, do not attempt to start the engine; avoid creating any source of ignition until the fuel vapors have dissipated.
- Do not fill containers inside a vehicle or on a truck or trailer bed with a plastic liner. Always place

Attaching the Trailer

This trailer uses a coupler that requires a 2-inch ball for the hitch.

1. Raise the trailer to a suitable height for your hitch.
2. Lift the coupler lever on the tongue while lowering the cover over the ball hitch (Figure 11).

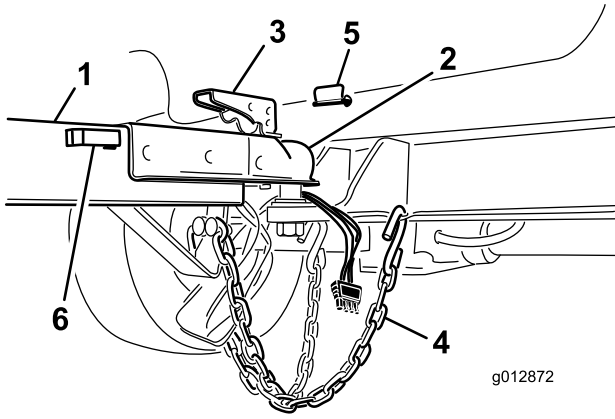

Figure 11

- | | |
|----------------------------------|-----------------------|
| 1. Tongue | 4. Auxiliary chains |
| 2. Ball socket | 5. Locking pin |
| 3. Coupler lever—locked position | 6. Hitch tube holster |

3. Close the coupler lever and ensure that it is securely locked.
4. Install the locking pin to lock the coupler lever.
5. Cross the safety chains and attach them to the holes on the hitch. Connect the machine-wire-harness connector to the connector on the towing vehicle.

Adding Fuel

- **Fuel tank capacity:** 18.9 L (5 US gallons)
- **Recommended Fuel:**
 - For best results, use only clean, fresh (less than 30 days old), unleaded gasoline with an octane rating of 87 or higher ((R+M)/2 rating method).
 - Ethanol: Gasoline with up to 10% ethanol (gasohol) or 15% MTBE (methyl tertiary butyl ether) by volume is acceptable. Ethanol and MTBE are not the same. Gasoline with 15% ethanol (E15) by volume is not approved for use. Never use gasoline that contains more than 10% ethanol by volume, such as E15 (contains 15% ethanol), E20 (contains 20% ethanol), or E85 (contains up to 85% ethanol). Using unapproved gasoline may cause performance problems and/or engine damage which may not be covered under warranty.
 - Do not use fuel containing methanol.
 - Do not store fuel either in the fuel tank or fuel containers over the winter unless a fuel stabilizer is used.
 - Do not add oil to fuel.

Important: Do not use fuel additives other than a fuel stabilizer/conditioner. Do not use fuel stabilizers with an alcohol base, such as ethanol, methanol, or isopropanol.

Filling the Fuel Tank

1. Shut off the engine.
2. Clean the area around the fuel tank cap and remove the cap (Figure 12).

Note: The fuel tank cap contains a gauge which shows the fuel level.

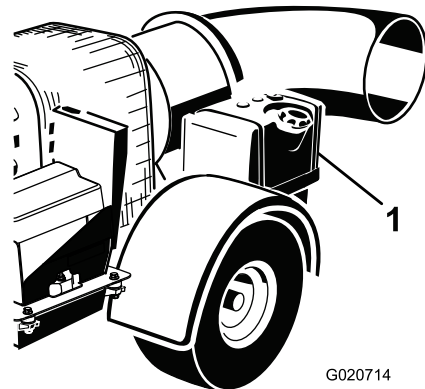

Figure 12

1. Fuel tank

3. Add fuel to the fuel tank, until the level is 6 mm to 13 mm (1/4 to 1/2 inch) below the bottom of the filler neck.

Note: This space in the tank allows fuel to expand. Do not fill the fuel tanks completely full.

4. Install the fuel-tank cap securely.
5. Wipe up any spilled fuel.

Checking the Engine-Oil Level

Before you start the engine and use the machine, check the oil level in the engine crankcase; refer to [Checking the Engine-Oil Level \(page 27\)](#).

Performing Daily Maintenance

Before starting the machine each day, perform the Each Use/Daily procedures listed in [Maintenance \(page 22\)](#).

During Operation

During Operation Safety

General Safety

- The owner/operator can prevent and is responsible for accidents that may cause personal injury or property damage.
- Wear appropriate clothing, including eye protection; long pants; substantial, slip-resistant footwear; and hearing protection. Tie back long hair and do not loose clothing or loose jewelry.
- Do not operate the machine while ill, tired, or under the influence of alcohol or drugs.
- Use your full attention while operating the machine. Do not engage in any activity that causes distractions; otherwise, injury or property damage may occur.
- Discharged air has considerable force and could cause injury or loss of footing. Stay away from the blower nozzle when the machine is operating.
- Keep all bystanders away; shut off the machine when bystanders enter the area, do not direct discharge toward them.
- Do not operate the machine when it is not connected to a towing vehicle.
- Do not run the engine in or direct the blower nozzle into a confined area without adequate ventilation. Engine exhaust contains carbon monoxide, an odorless gas that is fatal if inhaled.
- Do not carry passengers on the machine and keep bystanders and pets away from the machine during operation.
- Operate the machine only in good visibility to avoid holes or hidden hazards.
- Look behind and down before backing up to be sure of a clear path.
- Use care when approaching blind corners, shrubs, trees, or other objects that may obscure your vision.
- Never run an engine in an area where exhaust gasses are enclosed.
- Never leave a running machine unattended.
- Before you leave the operator's position, do the following:
 - Park the machine on a level surface.
 - Engage the tow vehicle parking brake.
 - Shut off the engine and remove the key (if equipped).
 - Wait for all movement to stop.
- When transporting the machine on public roads, follow all traffic regulations and use any additional

accessories that may be required by law, such as lights, turn signals, slow-moving vehicle (SMV) signs, and others as required.

- If the machine ever vibrates abnormally, stop the machine immediately, shut off the engine, remove the key, wait for all moving parts to stop, and inspect for damage. Repair all damage to the machine before resuming operation.
- Reduce speed when operating on rough, uneven terrain, and near curbs, holes, and other sudden changes in terrain.
- To avoid causing the machine to tip over, be careful when turning and avoid unsafe maneuvers.

Slope Safety

- Slopes are a major factor related to loss of control and rollover accidents, which can result in severe injury or death. You are responsible for safe slope operation. Operating the machine on any slope requires extra caution.
- Review the traction unit specifications to ensure that you do not exceed its slope capabilities.
- Evaluate the site conditions to determine if the slope is safe for machine operation, including surveying the site. Always use common sense and good judgment when performing this survey.
- Review the slope instructions, listed below, for operating the machine on slopes. Before you operate the machine, review the site conditions to determine whether you can operate the machine in the conditions on that day and at that site. Changes in the terrain can result in a change in slope operation for the machine.
 - Avoid starting, stopping, or turning the machine on slopes. Avoid making sudden changes in speed or direction. Make turns slowly and gradually.
 - Do not operate a machine under any conditions where traction, steering, or stability is in question.
 - Remove or mark obstructions such as ditches, holes, ruts, bumps, rocks, or other hidden hazards. Tall grass can hide obstructions. Uneven terrain could overturn the machine.
 - Be aware that operating the machine on wet grass, across slopes, or downhill may cause the machine to lose traction.
 - Use extreme caution when operating the machine near drop-offs, ditches, embankments, water hazards, or other hazards. The machine could suddenly roll over if a wheel goes over the edge or the edge caves in. Establish a safety area between the machine and any hazard.

Diagnostic Light

The diagnostic light (Figure 13) indicates the status of both the electronic system and the communication with the handheld remote.

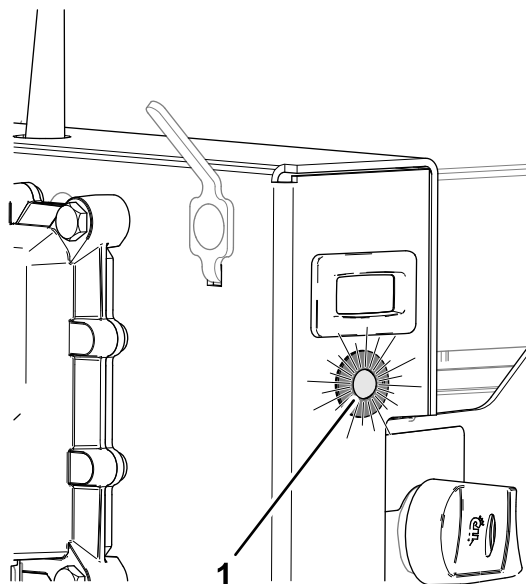

Figure 13

g342080

1. Diagnostic light

System Startup Flash Code

The system startup flash code runs each time the electronic system of the machine starts normally.

The system startup flash code displays when you turn the ignition key to the RUN position and the diagnostic light flashes in the following pattern:

- The light illuminates for 5 seconds.
- The light shuts off for 5 seconds.
- The light flashes 3 times a second until you push a button on the handheld remote.

Broken Communication Flash Code

The broken communication flash code runs when the wireless-control module cannot communicate with the handheld remote.

The broken communication flash code displays when you turn the ignition key to the RUN position and the diagnostic light flashes rapidly.

Possible handheld-remote communication issues include the following:

- The wireless-control module has not received a handheld-remote signal within 10 seconds of turning the ignition key to the RUN position.

- The handheld remote is too far from the machine.
- The handheld remote has low battery power.
- The wireless-control module is not associated with a handheld remote.

Active Fault Flash Code

The active fault flash code runs when the TEC controller detects an active fault.

The active fault flash code displays when you turn the ignition key to the RUN position and the diagnostic light flashes in the following pattern:

- The light illuminates for 5 seconds.
- The light flashes rapidly (with or without a pause).

Operating the Remote Control

- Failure to abide by the safety precautions may result in equipment failure, loss of authority to operate the equipment, and personal injury.
- Use and maintain the proper wiring. Follow the equipment manufacturer instructions. Improper, loose, and frayed wiring can cause system failure, equipment damage, and intermittent operation.
- Changes or modifications made to the machine that are not expressly approved by the manufacturer will void the warranty.
- The machine owner and operators must abide by all applicable federal, state, and local laws concerning machine installation and operation. Failure to comply could result in penalties and could void the user's authority to operate the machine.
- Ensure that the machinery and surrounding area is clear before operating. Do not activate the remote control system until you are certain that it is safe to do so.
- You can remove the power from the RF2CAN and TEC2403 controllers by removing the source power from the circuit.
- Use a damp cloth to keep the remote clean. Remove mud, concrete, and dirt after operation to prevent obstructing or clogging the buttons, levers, wiring, and switches.
- Do not allow liquid to enter the remote control or base-unit enclosures. Do not use high-pressure equipment to clean the remote control or base unit.
- Disconnect the RF2CAN and TEC2403 controllers before welding on the machine. Failure to disconnect the controllers may result in destruction of or damage to the controllers.
- Operate and store the machine only within the specified operation and storage temperatures.

Starting the Engine

⚠ WARNING

Rotating parts can cause serious personal injury.

- **Keep your hands, feet, hair, and clothing away from all moving parts of the machine to prevent injury.**
- **Never operate the machine with covers, shrouds, or guards removed.**

Before you start the engine, you must attach the machine to the towing vehicle.

1. Move the choke control to the ON position before starting a cold engine.

Note: A warm or hot engine may not require choking. After the engine starts, move the choke control to the OFF position.

2. Rotate the engine ignition key to the START position ([Figure 14](#)).

Note: If the key was left in the RUN position for an extended time, move the key to the OFF position before proceeding to the starting procedure.

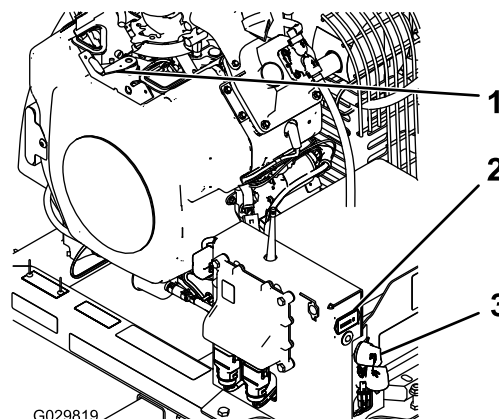

Figure 14

1. Choke control
2. Hour meter
3. Ignition switch

3. Engine Start only becomes energized by pressing the Start button while the Engine Start Enable Condition is active. The Engine Start Enable Condition becomes active only when the following Engine Start Enable Sequence has been performed ([Figure 15](#)):
 - Press the START button.
 - Then, press the rotate left button.
 - Then, press the rotate right button.
 - Then, press and hold the START button until the engine starts.

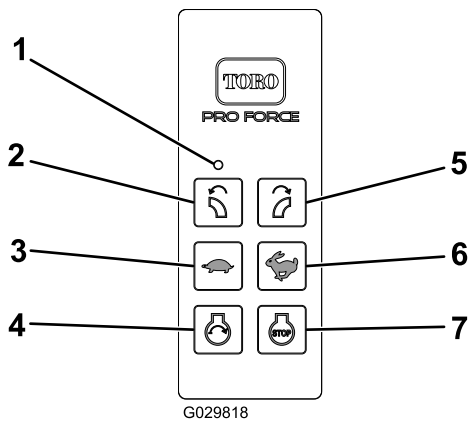

Figure 15

- | | |
|--------------------------|--------------------------|
| 1. LED light | 5. Rotate right |
| 2. Rotate left | 6. Increase engine speed |
| 3. Decrease engine speed | 7. Engine stop |
| 4. Engine start | |

Note: There is a time limit of 3 seconds between each button press. If the next button in the sequence is not pressed within 3 seconds of the last button press, the sequence is aborted and must be started from the beginning.

If any button other than the next appropriate button in the sequence is pressed the sequence is aborted.

Note: If the START button is not pressed within 10 seconds after pressing the ROTATE RIGHT button, or any other button is pressed in this period, the Engine Start Enable Condition expires.

Note: Engine Start Enable Condition persists for 10 seconds after pressing the ROTATE RIGHT button.

Note: Pressing the START button does not extend this time period—the maximum length of time that the Start Relay Control can be active is 10 seconds from pressing the ROTATE RIGHT button.

After the Engine Start Enable Condition expires, you must perform the Engine Start Enable Sequence again in order to energize the Start Relay Control with the START button. This cannot be performed for 10 seconds after the START button is released.

Note: If the sequence is aborted or the Engine Start Enable Condition expires, normal functionality of the ROTATE RIGHT and ROTATE LEFT buttons return to control the Chute Motor.

Important: Do not engage starter for more than 10 seconds at a time. If engine fails to start allow 10 second cool-down period

between attempts. Failure to follow these instructions can burn out starter motor.

- After the engine starts, move the choke control to the OFF position. If the engine stalls or hesitates, move the choke back to the ON position for a few seconds, then set the engine speed to the desired setting. Repeat this as required.

Shutting Off the Engine

- Decrease the engine speed to 3/4 throttle.
- Press the STOP button on the remote control.
- If leaving the machine, rotate the key to the OFF position and remove it from the ignition switch (Figure 14).

Using the Remote Control

The remote control activates (powers up) when any push button is pressed. To conserve battery power, the remote control stays active for approximately 3 seconds before automatically shutting down unless there is button activity within the 3 second limit. When the unit times out and powers down, all remote control LED activity stops (Figure 16). Pressing any button reactivates the remote control

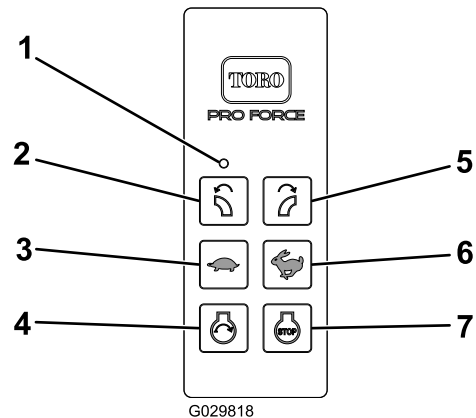

Figure 16

- | | |
|--------------------------|--------------------------|
| 1. LED light | 5. Rotate right |
| 2. Rotate left | 6. Increase engine speed |
| 3. Decrease engine speed | 7. Engine stop |
| 4. Engine start | |

The RF2CAN and TEC2403 controllers revert to Power Save Mode if the base unit is inactive for more than 2.5 hours without communication from the remote control. Power Save Mode is a low current state of the machine. The machine does not communicate with the remote control, does not activate outputs, and does not function as normal.

- When in the time-out mode the engine does not run (or quits running) and the remote control does not control any function.
- To wake controller in time-out mode, turn the key switch to the OFF position and then turn the key switch to the RUN position.
- To avoid controller time-out during operation, use the remote control to rotate the chute or change the engine speed at least every 2.5 hours.

Adjusting the Blower Nozzle Direction

You can change the direction of the blower nozzle from right to left by pressing the appropriate button on the remote control (Figure 17).

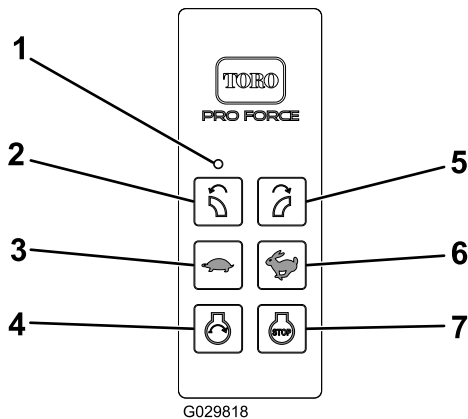
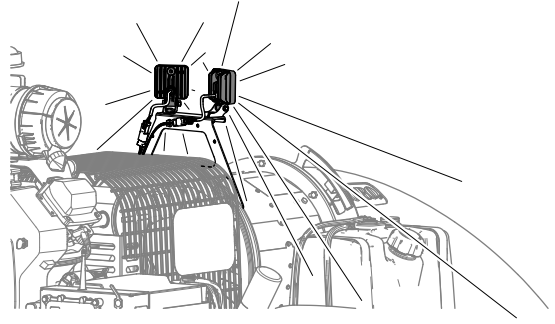

Figure 17

- | | |
|--------------------------|--------------------------|
| 1. LED light | 5. Rotate right |
| 2. Rotate left | 6. Increase engine speed |
| 3. Decrease engine speed | 7. Engine stop |
| 4. Engine start | |

Operating the Optional Lights

1. If the engine is not running, rotate the ignition key to the RUN/ACCESSORY position.
2. To switch the light ON or OFF, press the handheld remote buttons (Figure 18) in the following sequence:
 - A. ENGINE-START button
 - B. DECREASE ENGINE SPEED button



g342134

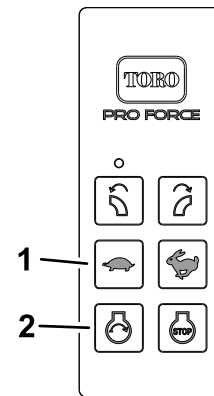

Figure 18

1. DECREASE ENGINE SPEED
2. ENGINE-START button

g343717

Moving the Machine from the Job Site

Important: Raise the blower nozzle before moving the machine from the job site. If you leave the blower nozzle in the down position during transport, the nozzle may contact the ground, and become damaged.

The Nozzle-Position Gauge

The nozzle-position gauge (Figure 19) is located behind the turbine housing, above the fuel tank.

Note: The decal on the nozzle-position gauge indicates the position of the nozzle relative to the ground.

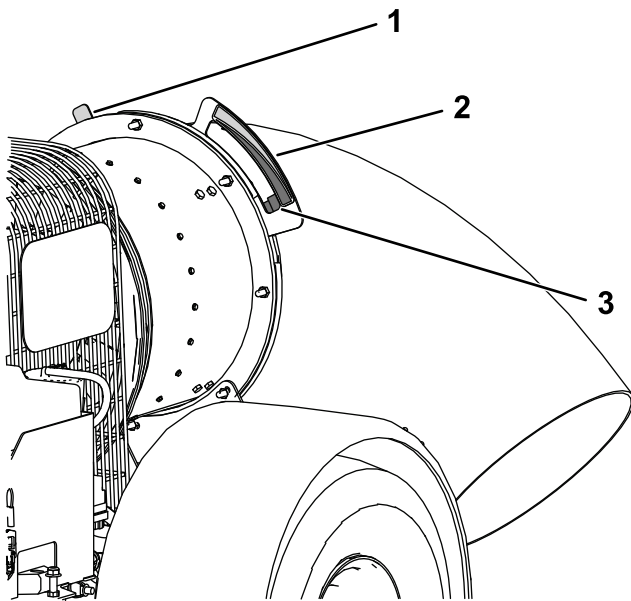

g314786

Figure 19

Some parts hidden for clarity.

1. Red pointer
2. Nozzle-position gauge and decal
3. Green pointer (shown in the window of the nozzle-position gauge window—left aligned blower nozzle)

There is a red pointer and a green pointer (Figure 19) attached to the blower nozzle.

Nozzle Alignment

- When the red pointer is visible in the nozzle position gauge, the blower nozzle is aligned to blow to the right of the machine.
- When the green pointer is visible in the nozzle position gauge, the blower nozzle is aligned to blow to the left of the machine.

Nozzle Angle

The pointer and gauge indicate the blower nozzle angle as follows:

- When the pointer is in the same colored region on the decal, that indicates that the chute opening is positioned more parallel to the ground.
- When a pointer tab is in the different colored region on the decal, that indicates that the chute opening is positioned more toward the ground.

Operating Tips

- Practice operating the blower. Blow the same direction that the wind blows to prevent material from blowing back into the cleared area.
- When blowing debris from a job site, run the engine at full throttle.
- Adjust the blower nozzle position so that the airstream blows under the debris.
- Use caution when blowing around newly planted sod; the airstream could disrupt the grass.

After Operation

After Operation Safety

General Safety

- Park the machine on a firm, level surface; shut off the engine, remove the key, wait for all moving parts to stop, and allow the machine to cool before adjusting, repairing, cleaning, or storing the machine.
- Only disconnect the machine from the traction unit while on a level surface.
- When disconnecting the machine, always chock the wheels to prevent movement.
- Do not store the machine or fuel container where there is an open flame, spark, or pilot light, such as on a water heater or other appliance.
- Keep all parts of the machine in good working condition and all hardware tightened.
- Replace all worn, damaged, or missing decals.

Towing Safety

- Before towing the machine, check with your local county or state safety towing regulations, in addition to meeting Department of Transportation (DOT) Safety Towing Regulations.
- Always shut off the engine and point the blower nozzle up before transporting.
- Tow only with a machine that has a hitch designed for towing. Do not attach towed equipment except at the hitch point.
- Always inspect the hitch and coupling for wear. Do not tow the machine with damaged or missing hitches, couplings, or chains.
- Check the tire air pressure on the machine. The tires should be inflated to 241 kpa (35 psi) cold. Also, check the tire-tread wear on the machine.
- Always properly attach the machine safety chains to the towing vehicle.
- Do not tow the machine faster than 88 km/h (55 mph). Recommended off-road towing is not to exceed 24 km/h (15 mph).
- Avoid sudden stops and starts. This can cause skidding or jack knifing. Smooth, gradual starts and stops will improve towing.
- Avoid sharp turns to prevent rolling.
- Chock the wheels to while parked to prevent movement.

Hauling the Machine

- Use care when loading or unloading the machine into a trailer or truck.
- Use full-width ramps for loading machine into trailer or truck.
- Tie the machine down securely using straps, chains, cable, or ropes. Both front and rear straps should be directed down and outward from the machine.

Connecting the Machine to the Towing Vehicle

- Check the towing-vehicle hitch ball and machine coupler for signs of wear or damage. Replace any parts that are worn or damaged before towing the machine.
- The machine coupler is 5.1 cm (2 inches). The towing vehicle ball hitch diameter must be 5.1 cm (2 inches). Use of different ball diameter will create an extremely dangerous condition which can result in separation of the coupler and ball or ball failure.
- After the tow bar has been connected to the machine, secure the machine coupler to the towing-vehicle hitch and ensure that the lock lever is in the locked position.

⚠ CAUTION

The safety chain is intended to prevent complete separation of the machine from the towing vehicle in the event of a tow bar failure.

If the safety chain is removed from the machine, do not tow the machine.

Maintenance

Note: Determine the left and right sides of the machine from the normal operating position.

Note: Download a free copy of the electrical or hydraulic schematic by visiting www.Toro.com and searching for your machine from the Manuals link on the home page.

Maintenance Safety

- Before cleaning, servicing, or adjusting the machine, do the following:
 - Park the machine on a level surface.
 - Shut off the engine, remove the key, disconnect the spark-plug wire, and wait for all moving parts to stop.
 - Chock the wheels.
 - Remove the machine from the traction unit.
 - Allow machine components to cool before performing maintenance.
- Perform only those maintenance instructions described in this manual. If major repairs are ever needed or you need assistance, contact an authorized Toro distributor.
- Support the machine with blocks or jack stands when working beneath it.
- Ensure that all guards are installed securely after maintaining or adjusting the machine.
- Do not allow untrained personnel to service the machine.
- Use jack stands to support the machine or components when required.
- Carefully release pressure from components with stored energy.
- Do not charge the batteries while servicing the machine.
- To reduce the potential fire hazard, keep the engine area free of excessive grease, grass, leaves, and accumulation of dirt.
- If possible, do not perform maintenance while the engine is running. Keep away from moving parts.
- If you must run the engine to perform a maintenance adjustment, keep your hands, feet, clothing, and all other parts of your body away from the engine and any moving parts. Keep bystanders away from the machine.
- Clean up oil and fuel spills.
- Keep all parts in good working condition and all fasteners tightened. Replace all damaged or missing decals.
- Do not interfere with the intended function of a safety device or reduce the protection provided by a safety device. Check their proper operation regularly.
- Do not overspeed the engine by changing the governor settings. To ensure safety and accuracy, have an authorized Toro distributor to check the maximum engine speed with a tachometer.
- If major repairs are ever necessary or assistance is required, contact an authorized Toro distributor.
- Altering this machine in any manner may affect the operation of the machine, performance, durability, or its use may result in injury or death. Such use could void the product warranty of The Toro Company.

Recommended Maintenance Schedule(s)

Maintenance Service Interval	Maintenance Procedure
After the first 8 hours	<ul style="list-style-type: none"> • Check the condition and the tension of the belt.
After the first 10 hours	<ul style="list-style-type: none"> • Check the torque of the wheel lug nuts.
Before each use or daily	<ul style="list-style-type: none"> • Check the engine-oil level. • Clean the engine screen and the oil cooler. • Check the tire air pressure. • Check the blower nozzle clamp. • Clean the nozzle guides.
Every 50 hours	<ul style="list-style-type: none"> • Check the condition and the tension of the belt.
Every 100 hours	<ul style="list-style-type: none"> • Replace the air filter element (more frequently if conditions are dusty or sandy). • Change the engine oil. • Check the condition of the tires.

Maintenance Service Interval	Maintenance Procedure
Every 200 hours	<ul style="list-style-type: none"> • Replace the carbon-canister air filter (Service more frequently if conditions are extremely dusty or sandy). • Replace the carbon-canister purge-line filter. • Replace the oil filter. • Check the spark plugs.
Every 500 hours	<ul style="list-style-type: none"> • Replace the fuel filter.

Important: Refer to your engine owner's manual for additional maintenance procedures.

Daily Maintenance Checklist

Duplicate this page for routine use.

Maintenance Check Item	For the week of:						
	Mon.	Tues.	Wed.	Thurs.	Fri.	Sat.	Sun.
Check the engine oil level.							
Clean the engine screen and the oil cooler.							
Inspect the air filter pre-cleaner.							
Check the tire air pressure.							
Check blower nozzle mounting clamp torque							
Clean the nozzle guides.							
Check any unusual engine noises.							
Check for fluid leaks.							
Touch-up damaged paint.							

Notation for Areas of Concern		
Inspection performed by:		
Item	Date	Information

Pre-Maintenance Procedures

⚠ CAUTION

Failure to properly maintain the machine could result in premature failure of machine systems causing possible harm to you or bystanders.

Keep the machine well maintained and in good working order as indicated in these instructions.

⚠ WARNING

If you leave the key in the ignition switch, someone could accidentally start the engine and seriously injure you or bystanders.

Remove the key from the ignition and disconnect the wires from the spark plugs before you do any maintenance. Set the wires aside so that they do not accidentally contact the spark plugs.

Preparing for Maintenance

1. Park the machine on a level surface.
2. Shut off the engine, remove the key, and wait for all moving parts to stop.
3. Chock the wheels.
4. Remove the machine from the traction unit.
5. Allow machine components to cool before performing maintenance.
6. Disconnect the spark-plug wire.

Preparing the Machine for Weld Repairs

Important: Failure to disconnect the battery may permanently damage to the wireless-control module and the TEC controller.

- Disconnect the negative-battery cable from the battery before welding on the machine.
- Connect the negative-battery cable to the battery after you finish welding on the machine.

Engine Maintenance

Engine Safety

- Shut off the engine before checking the oil or adding oil to the crankcase.
- Do not change the governor speed or overspeed the engine.

Servicing the Air Cleaner

Service Interval: Every 100 hours—Replace the air filter element (more frequently if conditions are dusty or sandy).

Checking the Air Filter

1. Check the air cleaner body for damage, which could possibly cause an air leak. Ensure that the cover seals around the air-cleaner body (Figure 20).

Note: Replace a damaged air-cleaner cover or housing.

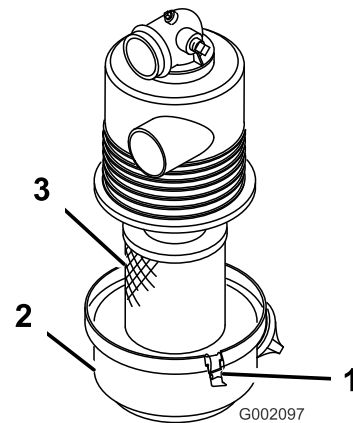

Figure 20

- | | |
|---------------------|-----------------------|
| 1. Latch | 3. Air-filter element |
| 2. Air-filter cover | |

2. Release the latches securing the air-filter cover to the air-filter housing (Figure 20).
3. Separate the air-filter cover from the air-filter housing, and clean the inside of the cover (Figure 20).
4. Gently slide the air-filter element out of the filter housing.

Note: To reduce the amount of dust dislodged, avoid knocking the filter against the air-filter housing.

5. Inspect the air-filter element.

- If the air-filter element is clean, install the filter element, refer to [Installing the Air Filter \(page 26\)](#).
- If the air-filter element is damaged, replace the filter element; refer to [Replacing the Air Filter \(page 26\)](#).

Replacing the Air Filter

1. Remove the air-filter element; refer to [Servicing the Air Cleaner \(page 25\)](#).
2. Inspect the new filter for shipping damage.

Note: Check the sealing end of the filter.

Important: Do not install a damaged filter.

3. Install the new air filter; refer to [Installing the Air Filter \(page 26\)](#).

Installing the Air Filter

Important: To prevent engine damage, always operate the engine with the complete air cleaner assembly installed.

Important: Do not use a damaged element.

Note: Cleaning of the used air-filter element is not recommended due to the possibility of damage to the filter media.

1. Clean the dirt ejection port located on the air-filter cover.
2. Remove the rubber outlet valve from the cover, clean the cavity, and replace the outlet valve.
3. Insert the air-filter element into air-filter housing ([Figure 20](#)).

Note: Ensure that the filter is sealed properly by applying pressure to the outer rim of the filter when installing it. Do not press on the flexible center of the filter.

4. Align the air-cleaner cover with the air-cleaner housing ([Figure 20](#)).
5. Secure the cover to the housing with the latches ([Figure 20](#)).

Servicing the Carbon Canister

Replacing the Carbon Canister Air Filter

Service Interval: Every 200 hours

1. Shut off the engine, remove the key, and wait for all moving parts to stop before leaving the operating position.
2. Remove and discard the carbon canister air filter, but retain the hoses ([Figure 21](#)).

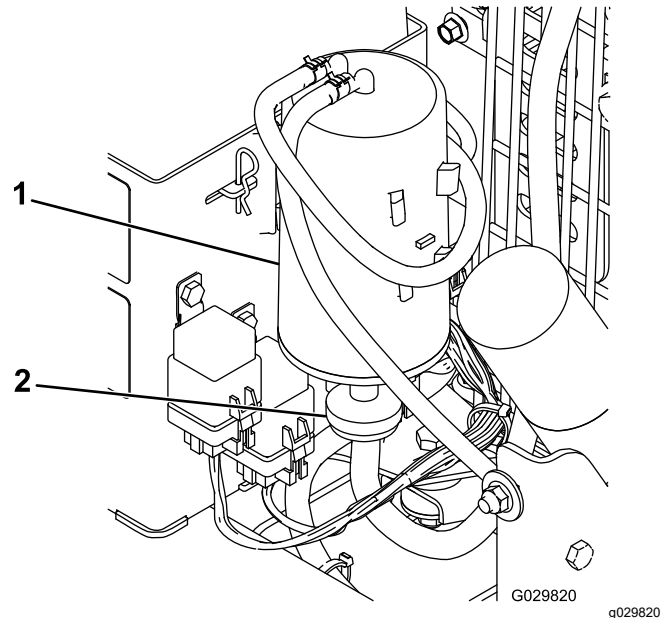

Figure 21

1. Carbon canister
 2. Carbon canister air filter
-
3. Install the new air filter and the previously removed hoses.

Replacing the Carbon Canister Purge-line Filter

Service Interval: Every 200 hours

Note: Check the purge-line filter occasionally for dirt. If the filter appears to be dirty, replace it.

1. Shut off the engine, remove the key, and wait for all moving parts to stop before leaving the operating position.
2. Move the spring-type hose clamps on both sides of the carbon canister purge-line filter away from the filter ([Figure 22](#)).

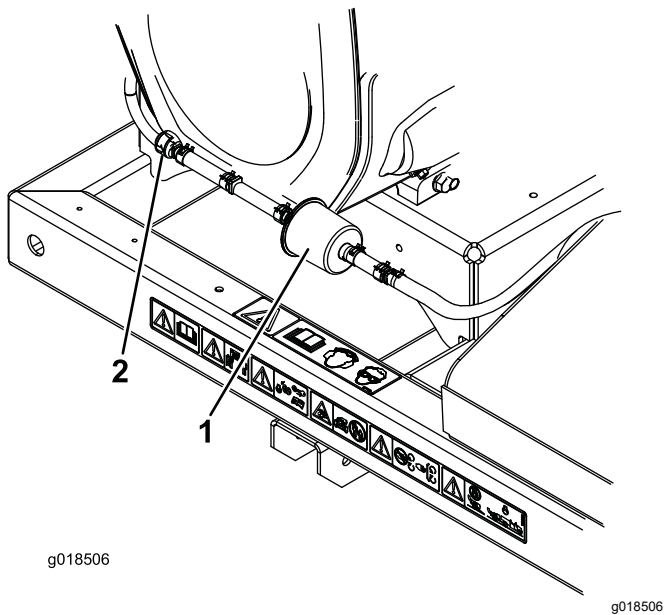

Figure 22

1. Carbon-canister purge-line filter
2. Check valve

3. Remove and discard the carbon filter (Figure 22).
4. Install a new filter into the hose with the arrow on the filter pointing toward the check valve and secure it with the hose clamps (Figure 22).

Servicing the Engine Oil

Note: Change the oil more frequently when the operating conditions are extremely dusty or sandy.

Oil Type: Detergent oil (API service SG, SH, SJ or higher)

Crankcase Capacity: with filter, 2 L (67 fl oz)

Viscosity: See the table below.

USE THESE SAE VISCOSITY OILS

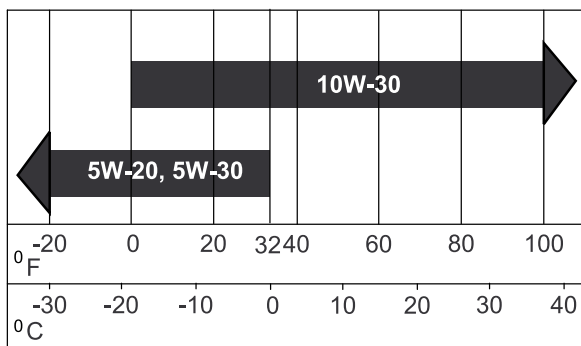

Figure 23

Checking the Engine-Oil Level

Service Interval: Before each use or daily

Note: Check the engine oil before the engine has been started for the day. If you have run the engine, allow the oil to drain back down to the sump for at least 10 minutes before checking. If the oil level is at or below the ADD mark on the dipstick, add oil to bring the oil level to the FULL mark. **Do not overfill.** If the oil level is between the FULL and ADD marks, no oil addition is required.

1. Park the machine on a level surface.
2. Shut off the engine, remove the key, and wait for all moving parts to stop before leaving the operating position.
3. Clean around the oil dipstick (Figure 24) so that dirt cannot fall into the hole and damage the engine.

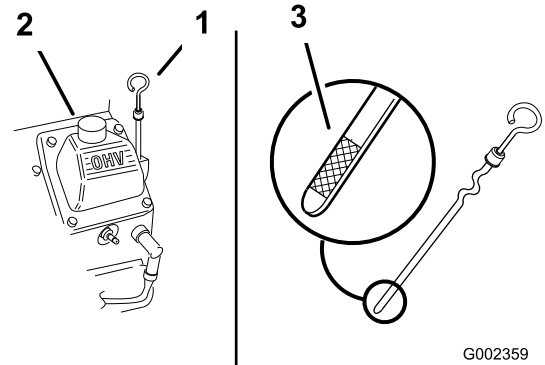

Figure 24

1. Oil dipstick
2. Filler hole
3. Oil-level range

4. Remove the oil dipstick and wipe the end clean (Figure 24).
5. Slide the oil dipstick fully into the filler tube (Figure 24).
6. Pull the dipstick out and look at the metal end. If the oil level is low, slowly pour only enough oil into the filler tube to raise the level to the FULL mark.

Important: Do not overfill the crankcase with oil and run the engine. Engine damage can result.

Changing the Oil

Service Interval: Every 100 hours

1. Start the engine and let it run for 5 minutes.

Note: A running engine will warm the oil, allowing it to easily drain from the engine.

- Park the machine so that the drain side is slightly lower than the opposite side to ensure the oil drains completely.
- Shut off the engine, remove the key, and wait for all moving parts to stop before leaving the operating position.
- Place a pan below the drain. Rotate the oil drain valve to allow the oil to drain (Figure 25).

Note: A hose may be inserted onto the drain valve to direct the oil flow. The hose is not included with the machine.

- When the oil has drained completely, close the drain valve.

Note: Dispose of the used oil at a recycling center.

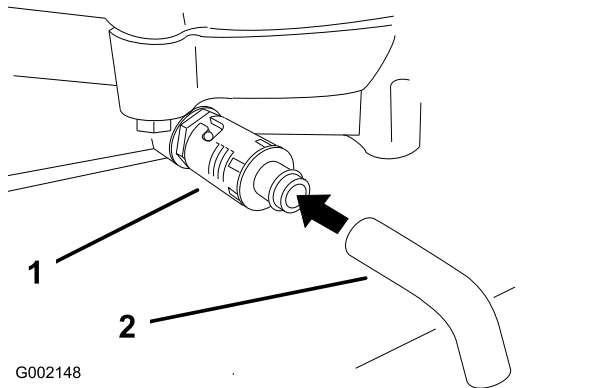

Figure 25

- Oil drain valve
- Oil drain hose (**Not included**)

- Slowly pour approximately 80% of the specified oil into the filler hole (Figure 24).
- Check the oil level; refer to [Checking the Engine-Oil Level \(page 15\)](#).

Changing the Oil Filter

Service Interval: Every 200 hours

Note: Change the oil filter more frequently when the operating conditions are extremely dusty or sandy.

- Drain the oil from the engine; refer to [Changing the Oil \(page 27\)](#).
- Remove the old filter and wipe the filter-gasket surface (Figure 26).

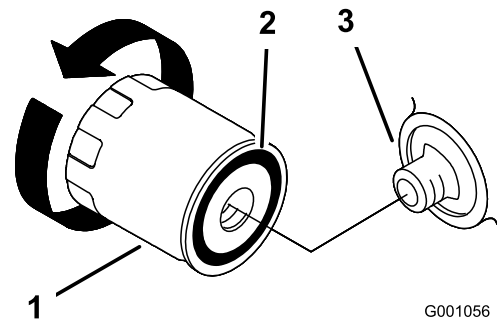

Figure 26

- Oil filter
- Gasket
- Adapter

- Apply a thin coat of new oil to the rubber gasket on the replacement filter (Figure 26).
- Install the replacement oil filter to the filter adapter, turn the oil filter clockwise until the rubber gasket contacts the filter adapter, then tighten the filter an additional 2/3 to 1 turn (Figure 26).
- Fill the crankcase with the proper type of new oil; refer to [Servicing the Engine Oil \(page 27\)](#).
- Run the engine for about 3 minutes, shut off the engine, and check for oil leaks around the oil filter.
- Check the engine oil level and add oil if needed; refer to [Checking the Engine-Oil Level \(page 27\)](#).

Servicing the Spark Plugs

Ensure that the air gap between the center and side electrodes is correct before installing the spark plugs. Use a spark plug wrench for removing and installing the spark plugs and a gapping tool/feeler gauge to check and adjust the air gap. Install new spark plugs if necessary.

Type: Champion® RC12YC, Champion® Platinum 3071 or equivalent

Air Gap: 0.76 mm (0.030 inch)

Checking the Spark Plugs

Service Interval: Every 200 hours

1. Look at the center of the spark plugs ([Figure 27](#)). If you see light brown or gray on the insulator, the engine is operating properly. A black coating on the insulator usually means that the air cleaner is dirty.

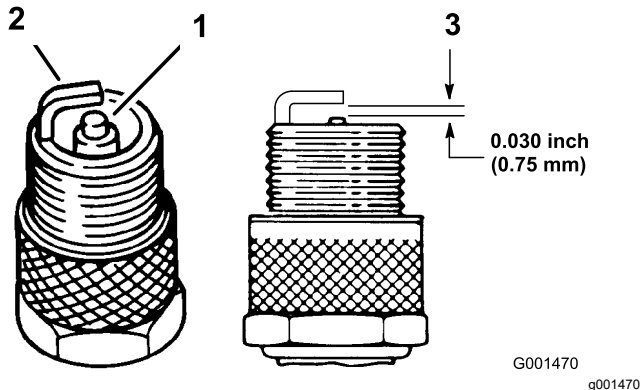

Figure 27

1. Center electrode insulator
2. Side electrode
3. Air gap—0.75 mm or 0.030 inch (not to scale)

Important: Always replace a spark plug when it has a black coating, worn electrodes, an oily film, or cracks.

2. Check the gap between the center and side electrodes ([Figure 27](#)). Bend the side electrode if the gap is not correct.

Removing the Spark Plugs

1. Shut off the engine, remove the key, and wait for all moving parts to stop before leaving the operating position.
2. Disconnect the spark-plug wires from the spark plugs ([Figure 28](#)).

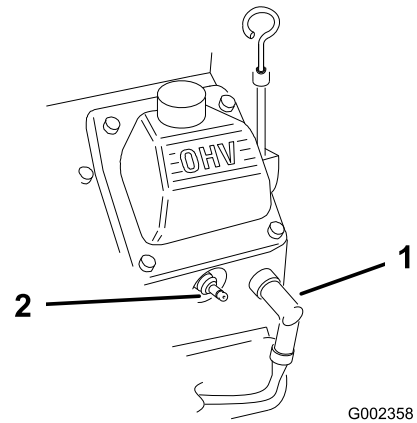

Figure 28

1. Spark-plug wire
2. Spark plug
3. Clean around the spark plugs to prevent dirt from falling into the engine and potentially causing damage.
4. Remove the spark plugs and the metal washers.

Installing the Spark Plugs

1. Install the spark plugs and the metal washer. Ensure that the air gap is set correctly; refer to [Checking the Spark Plugs \(page 29\)](#).
2. Tighten the spark plugs to 24 to 30 N·m (18 to 22 ft·lb).
3. Connect the spark-plug wires to the spark plugs ([Figure 28](#)).

Cleaning the Engine Screen and the Oil Cooler

Service Interval: Before each use or daily

Before each use, check and clean the engine screen and oil cooler. Remove any build up of grass, dirt or other debris from the oil cooler and engine screen ([Figure 29](#)).

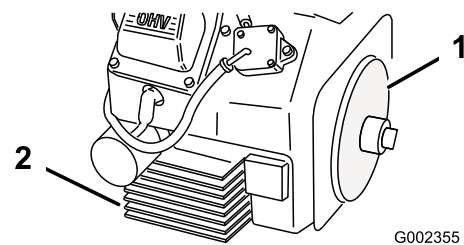

Figure 29

1. Engine screen
2. Oil cooler

Fuel System Maintenance

Replacing the Fuel Filter

Service Interval: Every 500 hours

Never install a dirty filter if it is removed from the fuel line.

1. Shut off the engine, remove the key, and wait for all moving parts to stop before leaving the operating position.
2. Allow the machine to cool down.
3. Squeeze the ends of the hose clamps together and slide them away from the filter (Figure 30).

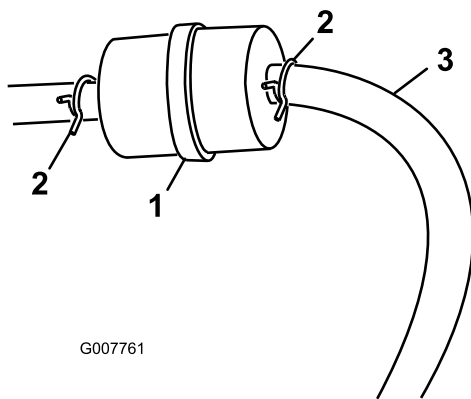

Figure 30

1. Fuel filter
2. Hose clamp
3. Fuel hose

4. Remove the filter from the fuel lines.
5. Install a new filter and move the hose clamps close to the filter (Figure 30).

Servicing the Fuel Tank

⚠ DANGER

In certain conditions, fuel is extremely flammable and highly explosive. A fire or explosion from fuel can burn you and others and can damage property.

- Drain fuel from the fuel tank when the engine is cold. Do this outdoors in an open area. Wipe up any spilled fuel.
- Never smoke when handling fuel, and stay away from an open flame or a spark that could ignite fuel fumes.

1. Park the machine on a level surface to ensure that the fuel tanks drain completely.
2. Shut off the engine, remove the key, and wait for all moving parts to stop before leaving the operating position.
3. Loosen the hose clamp at the fuel filter and slide it up the fuel line away from the fuel filter (Figure 30).
4. Disconnect the fuel line from the fuel filter (Figure 30).

Note: Allow the fuel to drain into a fuel container or drain pan (Figure 30).

Note: This is the best time to install a new fuel filter, as the fuel tank is empty.

5. Install the fuel line onto the fuel filter. Slide the hose clamp close to the fuel filter to secure the fuel line (Figure 30).

Electrical System Maintenance

Important: Before welding on the machine, disconnect the controller and the negative cable from the battery to prevent damage to the electrical system.

Electrical System Safety

- Disconnect the battery before repairing the machine. Disconnect the negative terminal first and the positive last. Connect the positive terminal first and the negative last.
- Charge the battery in an open, well-ventilated area, away from sparks and flames. Unplug the charger before connecting or disconnecting the battery. Wear protective clothing and use insulated tools.

Replacing the Fuses

Engine

An in-line fuse (15A) is incorporated into the engine wiring harness (Figure 31).

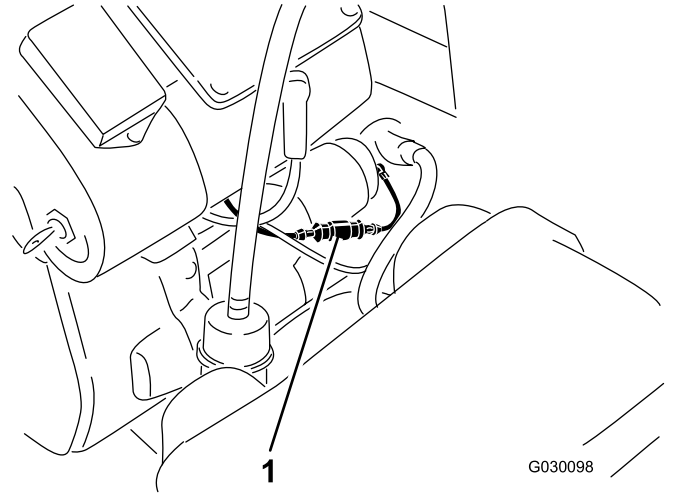

Figure 31

1. Fuse block

Receiver

A fuse block is incorporated into the receiver wire harness. It is located behind the receiver on the right side of the control tower (Figure 32).

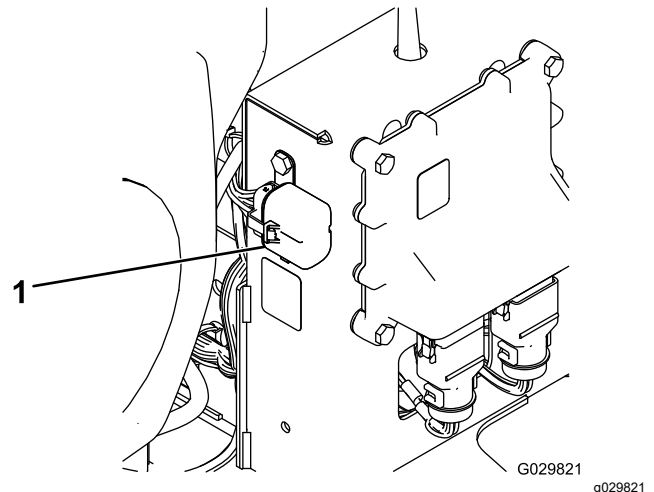

Figure 32

1. Fuse

Drive System Maintenance

Checking Tire Air Pressure

Service Interval: Before each use or daily

Check the tire pressure ([Figure 33](#)).

The correct tire pressure is 96.5 kPa (14 psi).

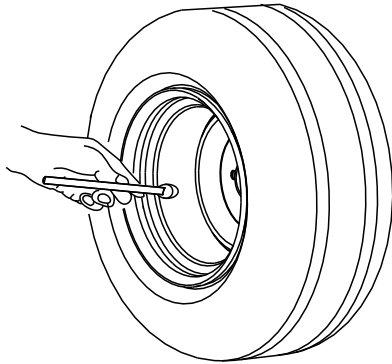

G001055

Figure 33

g001055

Inspecting the Tires

Service Interval: Every 100 hours

Operating accidents can damage a tire or rim, so inspect the tire condition after an accident.

The DOT tire information is located on the side of each tire. This information gives load and speed ratings. Replacement tires should have the same or better ratings.

[Figure 34](#) is an example of tire wear caused by under inflation.

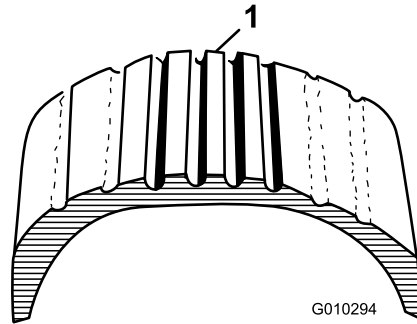

G010294

Figure 34

r:lg010294

1. Example of tire wear caused by underinflation

Torquing the Wheel Lug Nuts

Service Interval: After the first 10 hours

⚠ WARNING

Failure to maintain proper torque could result in failure or loss of wheel and could result in personal injury.

Torque wheel lug nuts to 95 to 122 N·m (70 to 90 ft-lb).

1. Prepare the machine for maintenance; refer to [Preparing for Maintenance \(page 24\)](#).
2. Torque the wheel lug nuts to 95 to 122 N·m (70 to 90 ft-lb).

[Figure 35](#) is an example of tire wear caused by over inflation.

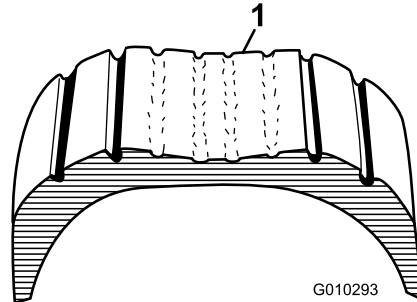

G010293

Figure 35

r:lg010293

1. Example of tire wear caused by overinflation

Belt Maintenance

Adjusting the Nozzle-Control Belt Tension

Service Interval: After the first 8 hours

Every 50 hours

If the nozzle-control belt slips while changing blower-nozzle direction, adjust the belt tension.

1. Prepare the machine for maintenance; refer to [Preparing for Maintenance \(page 24\)](#).
2. Loosen the 2 flange capscrews and 2 flange locknuts securing the motor-mounting bracket to the housing mount of the machine frame ([Figure 36](#)).

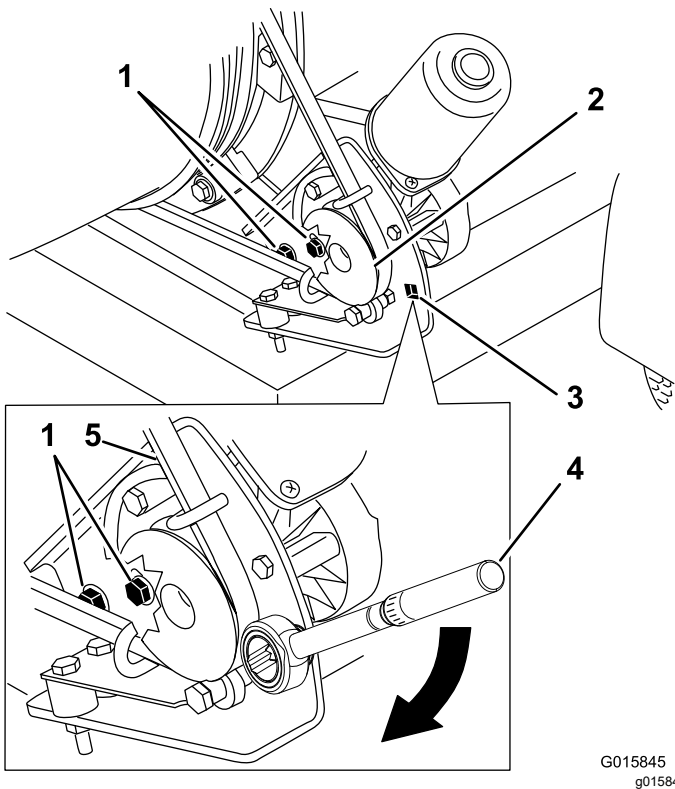

Figure 36

- | | |
|---------------------------|---|
| 1. Mounting bolts | 4. Torque wrench in pulley mounting bracket—22.6 to 26.0 N·m (200 to 230 in-lb) |
| 2. Pulley | 5. Belt |
| 3. Hole for torque wrench | |

3. Insert the drive of a torque wrench into the pulley mounting bracket as shown in [Figure 36](#).
4. Pivot the motor-mounting bracket away from the blower nozzle ([Figure 36](#)) until the torque wrench reads 22.6 to 26.0 N·m (200 to 230 in-lb).
5. While holding belt tension, tighten the 2 flange capscrews and 2 flange locknuts.

Blower Maintenance

Checking the Blower-Nozzle Clamp

Service Interval: Before each use or daily

1. Prepare the machine for maintenance; refer to [Preparing for Maintenance \(page 24\)](#).
2. Check the blower-nozzle clamp for signs of wear or damage ([Figure 37](#)).

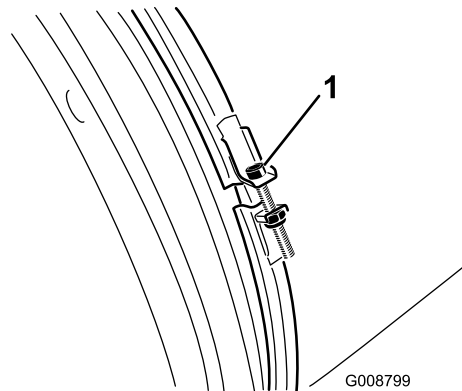

Figure 37

1. Blower-nozzle clamp

3. Check the blower-nozzle clamp daily to ensure that it is tight ([Figure 37](#)).

Important: If the blower nozzle contacts an obstacle or through a low area in the terrain, the blower-nozzle clamp could become loose.

4. If the clamp is loose, torque the nut of the clamp to 5.1 to 5.7 N·m (45 to 50 in-lb).

Cleaning the Nozzle Guides

Service Interval: Before each use or daily

1. Prepare the machine for maintenance; refer to [Preparing for Maintenance \(page 24\)](#).
2. Remove any grass, dirt or debris buildup around and in between the nozzle guides ([Figure 38](#)).

Note: If the nozzle guides are not free of debris, the nozzle may not rotate freely, which may damage the motor.

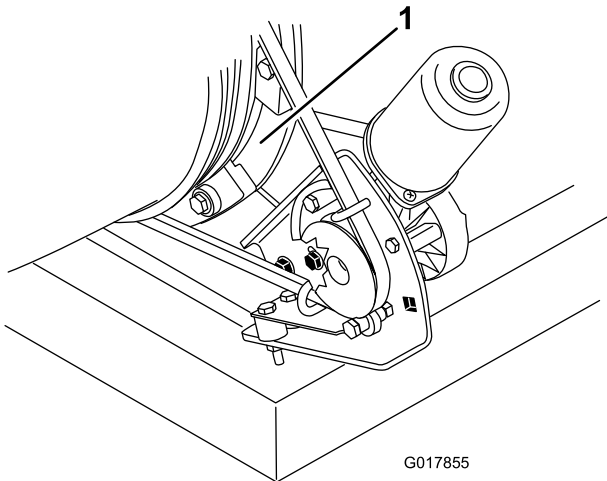

Figure 38

1. Nozzle guides

Handheld Remote Maintenance

Handheld Remote and the Wireless-Control Module

The handheld remote must link with the wireless-control module before you can use the remote control system. The handheld remote is associated to the wireless-control module at the factory. When you need to re-establish handheld remote and wireless-control module communication (e.g., introducing a new or spare remote control to an existing base unit or changing the signal frequency due to local interference issues), refer to [Associating the Remote and the Control Module \(page 34\)](#).

You can associate only Pro Force handheld remote to the Pro Force wireless-control module. Associating a Pro Force remote control to a different Pro Force wireless-control module disassociates that remote control from the original Pro Force machine.

Note: Local interference during operation may disassociate the handheld remote from the wireless-control module. Since the wireless-control module selects the best of numerous signal frequencies during the association process, move the machine to the area of signal disruption or disassociation, and perform the association procedure for best results.

Associating the Remote and the Control Module

Important: Read the entire procedure before starting it.

1. Prepare the machine for maintenance; refer to [Preparing for Maintenance \(page 24\)](#).
2. Rotate the ignition key to the STOP position.
3. While holding the handheld remote, stand near the wireless-control module in an area with an unobstructed, clear line of sight to the antenna ([Figure 39](#)).

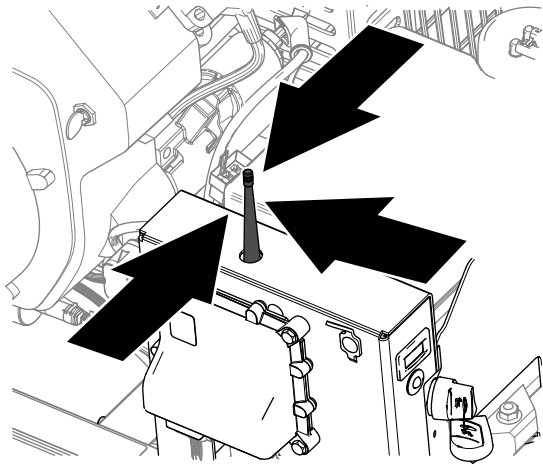

g343880

Figure 39

9. Release the ROTATE NOZZLE LEFT button ([Figure 40](#)), and rotate the ignition key to the STOP position.

Note: The remote-control system is ready for use with the associated handheld remote.

4. Simultaneously press and hold the ROTATE NOZZLE LEFT and ROTATE NOZZLE RIGHT buttons ([Figure 40](#)).

Note: The LED will blink about once per second.

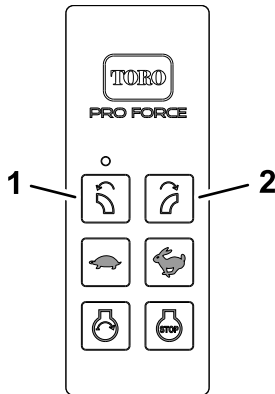

g343716

Figure 40

1. ROTATE NOZZLE LEFT button
2. ROTATE NOZZLE RIGHT button

5. Continue to hold both buttons until the LED begins blinking about twice per second.
6. Release both buttons.
7. Press and hold the ROTATE NOZZLE LEFT button ([Figure 40](#)).

Note: The LED will blink about twice per second.

8. Continue holding the ROTATE NOZZLE LEFT button ([Figure 40](#)) and turn the ignition key start to the RUN position.

Note: The LED turns solid if the procedure is successful. It may take up to 20 seconds for the LED turns solid.

Replacing the Remote Batteries

Battery specification: AAA (1.5 V)

Quantity: 4

1. Remove the 6 screws securing the cover halves of the handheld remote together, and remove the back cover (Figure 41).

Note: If possible, leave the rubber seal and steel gasket in the channel when removing the cover and batteries.

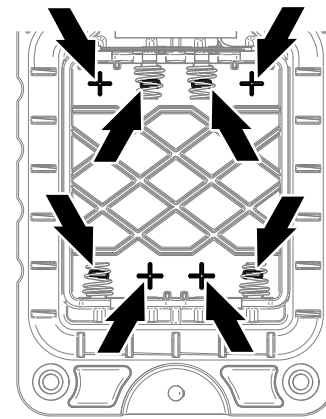

g341771

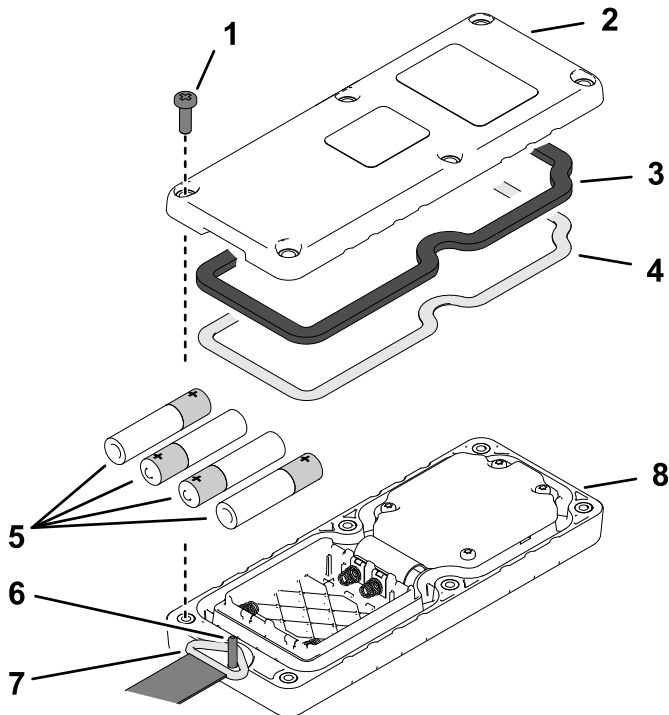

Figure 41

g341770

- | | |
|-----------------|------------------|
| 1. Screw | 5. AAA batteries |
| 2. Back cover | 6. Lanyard pin |
| 3. Seal | 7. Lanyard ring |
| 4. Steel gasket | 8. Front cover |

2. Remove the discharged batteries and properly dispose in accordance with local regulations.
3. Observing battery polarity as shown in Figure 42, insert the new batteries into the terminal cradles.

Note: When installing batteries, observe proper polarity markings (Figure 42) that are embossed onto the battery compartment to avoid damaging the terminal cradles. You will not damage the machine if you incorrectly installing the batteries in the handheld remote, but the handheld remote will not operate.

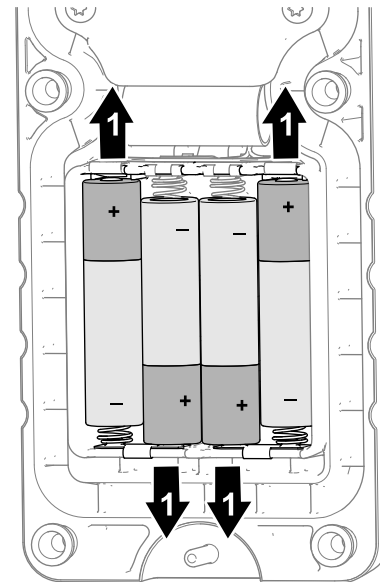

Figure 42

g341769

1. Positive battery polarity

4. Ensure that the steel gasket and rubber seal are seated in the channel in the cover half and align the back cover to the front cover (Figure 41).
5. Align the lanyard ring over the lanyard pin (Figure 41).
6. Assemble the back cover to the and front cover with 6 screws (Figure 41).
7. Torque the screws to 1.5 to 1.7 N·m (13 to 15 in-lb).

Troubleshooting Fault Codes

Resolving Fault Codes

If the diagnostic light indicates a system fault, perform the following procedures:

- [Entering Diagnostic Mode and Checking the Codes \(page 38\)](#)
- [Resetting the Fault Codes \(page 38\)](#)
- [Exiting Diagnostic Mode \(page 39\)](#)

Fault-Code Table

Fault Code	Diagnostic Light Flash Pattern	Fault Description	Fault Causes
11	Flash once—pause—flash once—long pause—then the pattern repeats	The TEC controller or the wireless-control module cannot communicate.	The wire-harness connector at the TEC controller or the wireless-control module is loose, corroded, or damaged.
			The wire harness is damaged; contact your authorized Toro distributor.
			The wireless-control module is damaged; contact your authorized Toro distributor.
12	Flash once—pause—flash 2 times—long pause—then the pattern repeats	The software version in the TEC, wireless-control module, or handheld remote is incompatibility with one of these other components.	Associate the handheld remote; refer to the machine <i>Operator's Manual</i> .
			Install the correct software; contact your authorized Toro distributor.
13	Flash once—pause—flash 3 times—long pause—then the pattern repeats	Wrong handheld remote associated with the wireless-control module.	The handheld remote is associated with a different Pro Force machine.
			The handheld remote is from the wrong type of machine, such as a MH-400 with a ProPass handheld.
14	Flash once—pause—flash 4 times—long pause—then the pattern repeats	The energize to run (ETR) circuit was interrupted because of low oil pressure (10 seconds or longer).	Check the engine-oil level, and adjust the oil level as necessary.
			The engine oil pressure switch is damaged or worn; contact your authorized Toro distributor.
			The wire harness is damaged; contact your authorized Toro distributor.
15	Flash once—pause—flash 5 times—long pause—then the pattern repeats	The energize to run (ETR) circuit was interrupted because of low machine battery voltage (less than 5.5 V).	Check the battery cable condition. Check that the cable hardware is tight.
			Test the battery, and if needed charge it; refer to the <i>Service Manual</i> . Replace the battery if needed.
			Test the engine alternator; refer to the <i>Service Manual</i> . Replace alternator if needed.
			Test the engine voltage regulator/rectifier; refer to the <i>Service Manual</i> . Replace regulator/rectifier if needed.

Entering Diagnostic Mode and Checking the Codes

1. Turn the ignition key to the STOP position.
2. Remove the tethered cap from the single-pin connector and the single-socket connector (Figure 43A).
3. Plug the single-pin connector into the single-socket connector (Figure 43B).

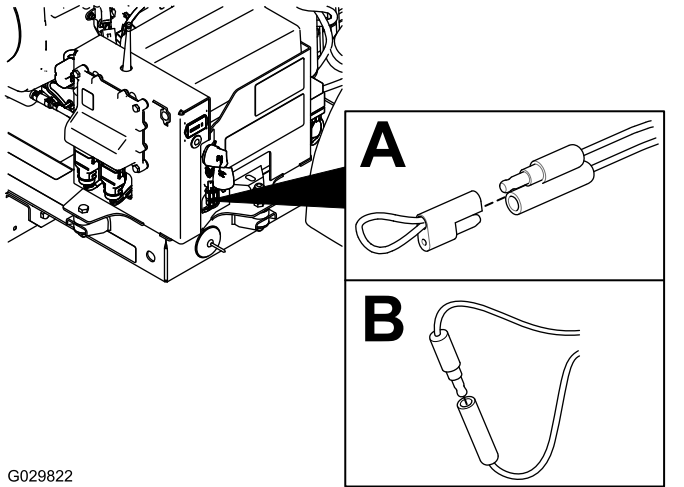

Figure 43

Resetting the Fault Codes

1. Turn the ignition key to the RUN position .
2. Remove the single-pin connector from the single-socket connector (Figure 44).

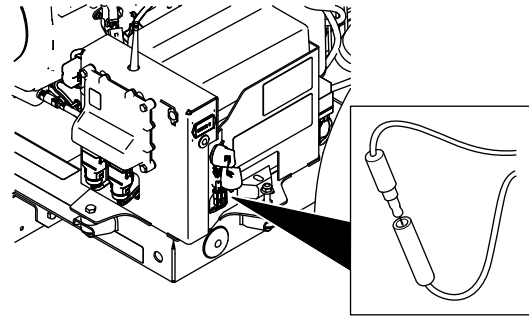

Figure 44

3. Plug the single-pin connector into the single-socket connector (Figure 44).

Note: The diagnostic light continuously flashes once per second.

4. Turn the key to the RUN position.
5. Watch the flash-pattern-sequence of the diagnostic light for the following signals, then consult the fault-code table:
 - The number and order of flashes in each flash-pattern-sequence.
 - The order and length of time for each pause in each flash-pattern-sequence.

Note: If there are multiple machine faults active, each fault will flash followed by a long pause. After each active faults has been displayed, the fault sequence will repeat. If no active faults exist, the diagnostic light will flash continuously once per second.

Exiting Diagnostic Mode

1. Turn the key to the OFF position (Figure 45).

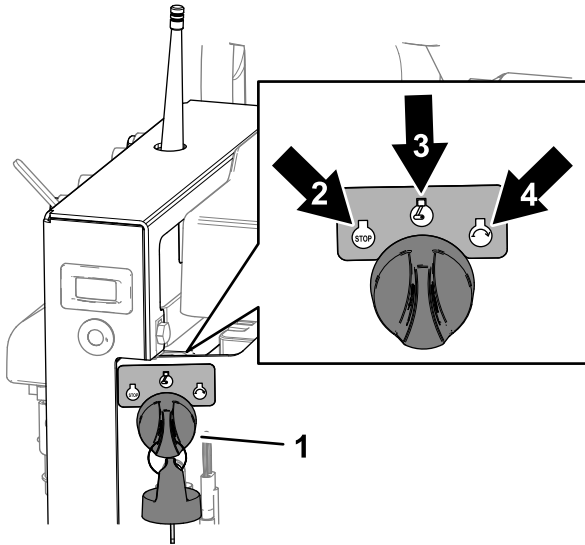

Figure 45

g341833

1. Ignition key
2. STOP position
3. RUN/ACCESSORY position
4. START position

2. Remove the single-pin connector from the single-socket connector (Figure 46).

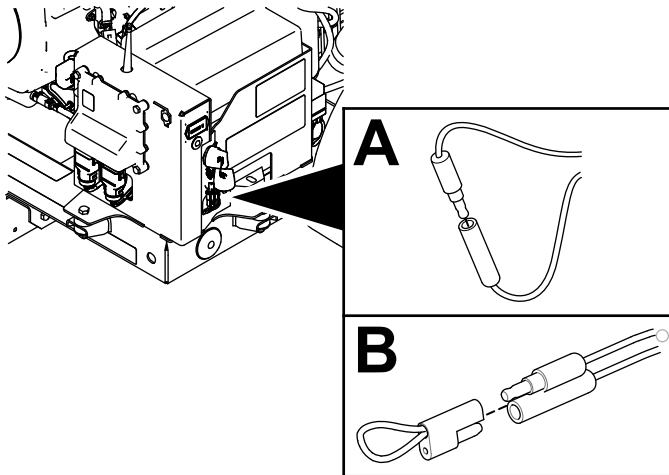

Figure 46

g342082

3. Plug the single-pin connector and the single-socket connector into tethered cap (Figure 46).

Cleaning

Washing the Machine

Important: Do not use brackish or reclaimed water to clean the machine.

Important: Do not pressure wash the machine.

- Wash the machine with mild detergent and water.
- Avoid excessive use of water, especially near the control console.

Disposing of Waste

Engine oil, engine and remote control batteries are pollutants to the environment. Dispose of these according to your state and local regulations.

Storage

Storage Safety

Shut off the machine, remove the key (if equipped), and wait for all movement to stop before you leave the operator's position. Allow the machine to cool before adjusting, servicing, cleaning, or storing it.

Storing the Machine

1. Park the machine on a level surface, shut off the engine, remove the key from the ignition, wait for all parts to stop moving, and remove the spark plug wire.
2. Remove grass clippings, dirt, and grime from the external parts of the entire machine, especially the engine. Clean dirt and chaff from the outside of the engine cylinder head fins and blower housing.

Important: You can wash the machine with mild detergent and water. Do not pressure wash the machine. Avoid excessive use of water.

3. Service the air cleaner; refer to [Servicing the Air Cleaner \(page 25\)](#).
4. Change the crankcase oil; refer to [Changing the Oil \(page 27\)](#).
5. Check the tire pressure; refer to [Checking Tire Air Pressure \(page 32\)](#).
6. Prepare the machine for storage when non-use occurs over 30 days. Prepare machine for storage as follows:
 - A. Add a petroleum-based stabilizer/conditioner to fuel in the tank. Follow mixing instructions from stabilizer manufacture. Do not use an alcohol based stabilizer (ethanol or methanol).

Note: A fuel stabilizer/conditioner is most effective when mixed with fresh fuel, and used at all times.
 - B. Run the engine to distribute conditioned fuel through the fuel system (5 minutes).
 - C. Shut off the engine, allow it to cool, and drain the fuel tank; refer to [Servicing the Fuel Tank \(page 30\)](#).
 - D. Start the engine and run it until it stops.
 - E. Choke the engine. Start and run the engine until it does not start.
 - F. Dispose of fuel properly. Recycle according to local codes.

Important: Do not store fuel containing stabilizer/conditioner longer than the duration recommended by the fuel-stabilizer manufacturer.

7. Remove the spark plug(s) and check its condition; refer to [Servicing the Spark Plugs \(page 29\)](#). With the spark plug(s) removed from the engine, pour 2 tablespoons of engine oil into the spark plug hole. Now use the starter to crank the engine and distribute the oil inside the cylinder. Install the spark plug(s). Do not install the wire on the spark plug(s).
8. Check and tighten all fasteners. Repair or replace any part that is damaged or missing.
9. Paint all scratched or bare metal surfaces. Paint is available from your authorized Toro distributor.
10. Store the machine in a clean, dry garage or storage area. Remove the key from the ignition switch and keep it out of reach of children or other unauthorized users. Cover the machine to protect it and keep it clean.

Notes:

California Proposition 65 Warning Information

What is this warning?

You may see a product for sale that has a warning label like the following:



WARNING: Cancer and Reproductive Harm—www.p65Warnings.ca.gov.

What is Prop 65?

Prop 65 applies to any company operating in California, selling products in California, or manufacturing products that may be sold in or brought into California. It mandates that the Governor of California maintain and publish a list of chemicals known to cause cancer, birth defects, and/or other reproductive harm. The list, which is updated annually, includes hundreds of chemicals found in many everyday items. The purpose of Prop 65 is to inform the public about exposure to these chemicals.

Prop 65 does not ban the sale of products containing these chemicals but instead requires warnings on any product, product packaging, or literature with the product. Moreover, a Prop 65 warning does not mean that a product is in violation of any product safety standards or requirements. In fact, the California government has clarified that a Prop 65 warning "is not the same as a regulatory decision that a product is 'safe' or 'unsafe.'" Many of these chemicals have been used in everyday products for years without documented harm. For more information, go to <https://oag.ca.gov/prop65/faqs-view-all>.

A Prop 65 warning means that a company has either (1) evaluated the exposure and has concluded that it exceeds the "no significant risk level"; or (2) has chosen to provide a warning based on its understanding about the presence of a listed chemical without attempting to evaluate the exposure.

Does this law apply everywhere?

Prop 65 warnings are required under California law only. These warnings are seen throughout California in a wide range of settings, including but not limited to restaurants, grocery stores, hotels, schools, and hospitals, and on a wide variety of products. Additionally, some online and mail order retailers provide Prop 65 warnings on their websites or in catalogs.

How do the California warnings compare to federal limits?

Prop 65 standards are often more stringent than federal and international standards. There are various substances that require a Prop 65 warning at levels that are far lower than federal action limits. For example, the Prop 65 standard for warnings for lead is 0.5 µg/day, which is well below the federal and international standards.

Why don't all similar products carry the warning?

- Products sold in California require Prop 65 labelling while similar products sold elsewhere do not.
- A company involved in a Prop 65 lawsuit reaching a settlement may be required to use Prop 65 warnings for its products, but other companies making similar products may have no such requirement.
- The enforcement of Prop 65 is inconsistent.
- Companies may elect not to provide warnings because they conclude that they are not required to do so under Prop 65; a lack of warnings for a product does not mean that the product is free of listed chemicals at similar levels.

Why does Toro include this warning?

Toro has chosen to provide consumers with as much information as possible so that they can make informed decisions about the products they buy and use. Toro provides warnings in certain cases based on its knowledge of the presence of one or more listed chemicals without evaluating the level of exposure, as not all the listed chemicals provide exposure limit requirements. While the exposure from Toro products may be negligible or well within the "no significant risk" range, out of an abundance of caution, Toro has elected to provide the Prop 65 warnings. Moreover, if Toro does not provide these warnings, it could be sued by the State of California or by private parties seeking to enforce Prop 65 and subject to substantial penalties.



The Toro Warranty

Two-Year or 1,500 Hours Limited Warranty

Conditions and Products Covered

The Toro Company warrants your Toro Commercial product ("Product") to be free from defects in materials or workmanship for 2 years or 1,500 operational hours*, whichever occurs first. This warranty is applicable to all products with the exception of Aerators (refer to separate warranty statements for these products). Where a warrantable condition exists, we will repair the Product at no cost to you including diagnostics, labor, parts, and transportation. This warranty begins on the date the Product is delivered to the original retail purchaser.

* Product equipped with an hour meter.

Instructions for Obtaining Warranty Service

You are responsible for notifying the Commercial Products Distributor or Authorized Commercial Products Dealer from whom you purchased the Product as soon as you believe a warrantable condition exists. If you need help locating a Commercial Products Distributor or Authorized Dealer, or if you have questions regarding your warranty rights or responsibilities, you may contact us at:

Toro Commercial Products Service Department
8111 Lyndale Avenue South
Bloomington, MN 55420-1196

952-888-8801 or 800-952-2740
E-mail: commercial.warranty@toro.com

Owner Responsibilities

As the product owner, you are responsible for required maintenance and adjustments stated in your *Operator's Manual*. Repairs for product issues caused by failure to perform required maintenance and adjustments are not covered under this warranty.

Items and Conditions Not Covered

Not all product failures or malfunctions that occur during the warranty period are defects in materials or workmanship. This warranty does not cover the following:

- Product failures which result from the use of non-Toro replacement parts, or from installation and use of add-on, or modified non-Toro branded accessories and products.
- Product failures which result from failure to perform recommended maintenance and/or adjustments.
- Product failures which result from operating the Product in an abusive, negligent, or reckless manner.
- Parts consumed through use that are not defective. Examples of parts which are consumed, or used up, during normal Product operation include, but are not limited to, brake pads and linings, clutch linings, blades, reels, rollers and bearings (sealed or greasable), bed knives, spark plugs, castor wheels and bearings, tires, filters, belts, and certain sprayer components such as diaphragms, nozzles, flow meters, and check valves.
- Failures caused by outside influence, including, but not limited to, weather, storage practices, contamination, use of unapproved fuels, coolants, lubricants, additives, fertilizers, water, or chemicals.
- Failure or performance issues due to the use of fuels (e.g. gasoline, diesel, or biodiesel) that do not conform to their respective industry standards.
- Normal noise, vibration, wear and tear, and deterioration. Normal "wear and tear" includes, but is not limited to, damage to seats due to wear or abrasion, worn painted surfaces, scratched decals or windows.

Countries Other than the United States or Canada

Customers who have purchased Toro products exported from the United States or Canada should contact their Toro Distributor (Dealer) to obtain guarantee policies for your country, province, or state. If for any reason you are dissatisfied with your Distributor's service or have difficulty obtaining guarantee information, contact your Authorized Toro Service Center.

Parts

Parts scheduled for replacement as required maintenance are warranted for the period of time up to the scheduled replacement time for that part. Parts replaced under this warranty are covered for the duration of the original product warranty and become the property of Toro. Toro will make the final decision whether to repair any existing part or assembly or replace it. Toro may use remanufactured parts for warranty repairs.

Deep Cycle and Lithium-Ion Battery Warranty

Deep cycle and Lithium-Ion batteries have a specified total number of kilowatt-hours they can deliver during their lifetime. Operating, recharging, and maintenance techniques can extend or reduce total battery life. As the batteries in this product are consumed, the amount of useful work between charging intervals will slowly decrease until the battery is completely worn out. Replacement of worn out batteries, due to normal consumption, is the responsibility of the product owner. Note: (Lithium-Ion battery only): Refer to the battery warranty for additional information.

Lifetime Crankshaft Warranty (ProStripe 02657 Model Only)

The ProStripe which is fitted with a genuine Toro Friction Disc and Crank-Safe Blade Brake Clutch (integrated Blade Brake Clutch (BBC) + Friction Disc assembly) as original equipment and used by the original purchaser in accordance with recommended operating and maintenance procedures, are covered by a Lifetime Warranty against engine crankshaft bending. Machines fitted with friction washers, Blade Brake Clutch (BBC) units and other such devices are not covered by the Lifetime Crankshaft Warranty.

Maintenance is at Owner's Expense

Engine tune-up, lubrication, cleaning and polishing, replacement of filters, coolant, and completing recommended maintenance are some of the normal services Toro products require that are at the owner's expense.

General Conditions

Repair by an Authorized Toro Distributor or Dealer is your sole remedy under this warranty.

The Toro Company is not liable for indirect, incidental or consequential damages in connection with the use of the Toro Products covered by this warranty, including any cost or expense of providing substitute equipment or service during reasonable periods of malfunction or non-use pending completion of repairs under this warranty. Except for the Emissions warranty referenced below, if applicable, there is no other express warranty. All implied warranties of merchantability and fitness for use are limited to the duration of this express warranty.

Some states do not allow exclusions of incidental or consequential damages, or limitations on how long an implied warranty lasts, so the above exclusions and limitations may not apply to you. This warranty gives you specific legal rights, and you may also have other rights which vary from state to state.

Note Regarding Emissions Warranty

The Emissions Control System on your Product may be covered by a separate warranty meeting requirements established by the U.S. Environmental Protection Agency (EPA) and/or the California Air Resources Board (CARB). The hour limitations set forth above do not apply to the Emissions Control System Warranty. Refer to the Engine Emission Control Warranty Statement supplied with your product or contained in the engine manufacturer's documentation.



Count on it.