



Form No. 3443-292 Rev A

**Count on it.**

**Operator's Manual**

**Pro Force<sup>®</sup> Debris Blower**

Model No. 44552—Serial No. 408000000 and Up

Model No. 44552TE—Serial No. 408000000 and Up



This product complies with all relevant European directives; for details, please see the separate product specific Declaration of Conformity (DOC) sheet.

It is a violation of California Public Resource Code Section 4442 or 4443 to use or operate the engine on any forest-covered, brush-covered, or grass-covered land unless the engine is equipped with a spark arrester, as defined in Section 4442, maintained in effective working order or the engine is constructed, equipped, and maintained for the prevention of fire.

The enclosed engine owner's manual is supplied for information regarding the US Environmental Protection Agency (EPA) and the California Emission Control Regulation of emission systems, maintenance, and warranty. Replacements may be ordered through the engine manufacturer.

The DOT tire information is located on the side of each tire. This information gives load and speed ratings. Replacement tires should have the same or better ratings. Ensure that the tires meet or exceed the weight requirements of your machine.

**Important: Changing or modifying the machine without the express approval from the party responsible for compliance could void your authority to operate the equipment.**

**Do not change or modify the machine without the express approval from the party responsible for compliance.**

Failure to abide by the safety precautions may result in equipment failure, loss of authority to operate the equipment, and personal injury.

The machine owner and operators must abide by all applicable federal, state, and local laws concerning machine installation and operation. Failure to comply could result in penalties and could void the user's authority to operate the machine.

#### Electromagnetic Compatibility

**Domestic:** This device complies with FCC Rules Part 15. Operation is subject to the following two conditions: (1) This device may not cause harmful interference and (2) this device must accept any interference that may be received, including interference that may cause undesirable operation.

This equipment generates and uses radio frequency energy and if not installed and used properly, in strict accordance with the manufacturer's instructions, may cause interference to radio and television reception. It has been type tested and found to comply within the limits of a FCC Class B computing device in accordance with the specifications in Subpart J of Part 15 of FCC Rules, as stated above. However, there is no guarantee that interference will not occur in a particular installation. If this equipment does cause interference to radio or television reception, which can be determined by turning the equipment off and on, the user is encouraged to try to correct the interference by one or more of the following measures: Reorient the receiving antenna, relocate the remote control receiver with respect to the radio/TV antenna or plug the controller into a different outlet so that the controller and radio/TV are on different branch circuits. If necessary, the user should consult the dealer or an experienced radio/television technician for additional suggestions. The user may find the following booklet helpful: "How to Identify and Resolve Radio-TV Interference Problems". This booklet is available from the U.S. Government Printing Office, Washington, DC 20402. Stock No. 004-000-00345-4.

FCC ID: W7OMRF24J40MDME-Base,  
OA3MRF24J40MA-Hand Held

IC: 7693A-24J40MDME-Base, 7693A-24J40MA-Hand Held

Operation is subject to the following two conditions: (1) this device may not cause interference, and (2) this device must accept any interference, including interference that may cause undesired operation of the device.

#### Japan Electromagnetic Compatibility Certification

Handheld:  R 204-520022

RF2CAN:  R 204-520297

#### Mexico Electromagnetic Compatibility Certification

Handheld: IFTEL : RCPMIMR15-2209

RF2CAN: IFTEL : RCPMIMR15-0142

#### Korea Electromagnetic Compatibility Certification

(Decal provided in separate kit)

Handheld:  MSIP-CRM-TZQ-SMHH  
해당 무선설비는 전파혼신 가능성이 있으므로 인명안전과 관련된 서비스는 할 수 없음

RF2CAN:  MSIP-CRM-TZQ-MRF-E  
MSIP-CRM-TZQ-RF2CAN  
해당 무선설비는 전파혼신 가능성이 있으므로 인명안전과 관련된 서비스는 할 수 없음

Singapore Electromagnetic Compatibility Certification	
Handheld:	TWM240007_IDA_N4021-15
RF2CAN:	TWM-240005_IDA_N4024-15

Morocco Electromagnetic Compatibility Certification	
AGREE PAR L'ANRT MAROC	
Numero d'agrement:	MR 14092 ANRT 2017
Delivre d'agrement:	29/05/2017

**⚠ WARNING**

**CALIFORNIA  
Proposition 65 Warning**

**The engine exhaust from this product contains chemicals known to the State of California to cause cancer, birth defects, or other reproductive harm.**

**Battery posts, terminals, and related accessories contain lead and lead compounds, chemicals known to the State of California to cause cancer and reproductive harm. Wash hands after handling.**

**Use of this product may cause exposure to chemicals known to the State of California to cause cancer, birth defects, or other reproductive harm.**

# Introduction

The debris blower is towed behind a ride-on machine which is intended to be used by professional, hired operators in commercial applications. It is primarily designed to use wind power to quickly clear large areas of unwanted debris on well-maintained lawns in parks, golf courses, sports fields, and on commercial grounds. Using this product for purposes other than its intended use could prove dangerous to you and bystanders.

Read this information carefully to learn how to operate and maintain your product properly and to avoid injury and product damage. You are responsible for operating the product properly and safely.

Visit [www.Toro.com](http://www.Toro.com) for product safety and operation training materials, accessory information, help finding a dealer, or to register your product.

Whenever you need service, genuine Toro parts, or additional information, contact an Authorized Service Dealer or Toro Customer Service and have the model and serial numbers of your product ready. **Figure 1** identifies the location of the model and serial numbers on the product. Write the numbers in the space provided.

**Important:** With your mobile device, you can scan the QR code on the serial number (if equipped) to access warranty, parts, and other product information.

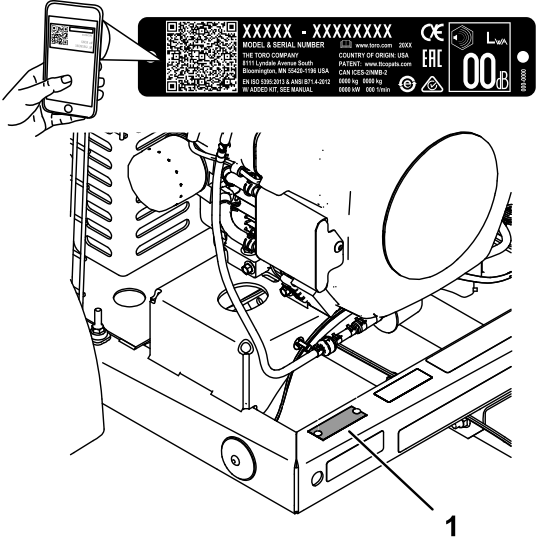

**Figure 1**

1. Model and serial number location

g341649

Model No. _____
Serial No. _____

This manual identifies potential hazards and has safety messages identified by the safety-alert symbol (Figure 2), which signals a hazard that may cause serious injury or death if you do not follow the recommended precautions.



**Figure 2**  
Safety-alert symbol

g000502

This manual uses 2 words to highlight information. **Important** calls attention to special mechanical information and **Note** emphasizes general information worthy of special attention.

# Contents

- Safety ..... 5
  - General Safety ..... 5
  - Safety and Instructional Decals ..... 6
- Setup ..... 8
  - 1 Connecting the Battery ..... 8
  - 2 Mounting the Hitch to the Debris Blower ..... 9
  - 3 Connecting the Debris Blower to the Tow Vehicle ..... 9
  - 4 Installing the Batteries into the Handheld Remote ..... 10
- Product Overview ..... 11
  - Controls ..... 11
    - Handheld Remote ..... 11
  - Specifications ..... 13
  - Radio Specifications ..... 13
  - Attachments/Accessories ..... 13
- Before Operation ..... 13
  - Before Operation Safety ..... 13
  - Fuel Specification ..... 14
  - Using Stabilizer/Conditioner ..... 14
  - Filling the Fuel Tank ..... 14
  - Performing Daily Maintenance ..... 14
- During Operation ..... 15
  - During Operation Safety ..... 15
  - Diagnostic Light ..... 16
  - Starting the Engine ..... 16
  - Shutting Off the Engine ..... 17
  - Using the Remote Control ..... 17
  - Running the Engine ..... 17

- Adjusting the Blower Nozzle Direction ..... 19
- Moving the Machine from the Job Site ..... 19
- The Nozzle-Position Gauge ..... 20
- Operating the Optional Lights ..... 20
- Operating Tips ..... 21
- After Operation ..... 21
  - After Operation Safety ..... 21
  - Remote Control Operation ..... 21
  - Hauling ..... 21
- Maintenance ..... 22
  - Maintenance Safety ..... 22
  - Recommended Maintenance Schedule(s) ..... 23
    - Daily Maintenance Checklist ..... 24
  - Pre-Maintenance Procedures ..... 25
    - Preparing for Machine ..... 25
    - Preparing the Machine for Weld Repairs ..... 25
- Engine Maintenance ..... 25
  - Engine Safety ..... 25
  - Servicing the Air Cleaner ..... 25
  - Engine Oil Specification ..... 27
  - Checking the Engine-Oil Level ..... 27
  - Changing the Oil ..... 28
  - Changing the Oil Filter ..... 28
  - Servicing the Spark Plugs ..... 29
  - Cleaning the Engine Screen and the Oil Cooler ..... 30
- Fuel System Maintenance ..... 30
  - Servicing the Carbon Canister ..... 30
  - Replacing the Fuel Filter ..... 31
  - Servicing the Fuel Tank ..... 31
- Electrical System Maintenance ..... 32
  - Electrical System Safety ..... 32
  - Fuses ..... 32
- Drive System Maintenance ..... 33
  - Checking Tire Air Pressure ..... 33
  - Torquing the Wheel Lug Nuts ..... 33
  - Inspecting the Tires ..... 33
- Belt Maintenance ..... 34
  - Adjusting the Nozzle-Control Belt Tension ..... 34
- Blower Maintenance ..... 35
  - Checking the Blower-Nozzle Clamp ..... 35
  - Cleaning the Nozzle Guides ..... 35
- Handheld Remote Maintenance ..... 36
  - Handheld Remote and the Wireless-Control Module ..... 36
  - Replacing the Remote Batteries ..... 37
- Troubleshooting Fault Codes ..... 39
  - Resolving Fault Codes ..... 39
  - Entering Diagnostic Mode and Checking the Codes ..... 40
  - Resetting the Fault Codes ..... 40
  - Exiting Diagnostic Mode ..... 40
- Cleaning ..... 41
  - Washing the Machine ..... 41
  - Disposing of Waste ..... 41
- Storage ..... 42

# Safety

This machine has been designed in accordance with ANSI B71.4-2017.

## General Safety

This product is capable of throwing objects. Always follow all safety instructions to avoid serious personal injury.

- Read and understand the contents of both this *Operator's Manual* and the operator's manual of the traction unit before using this machine. Ensure that everyone using this product knows how to use this machine and the traction unit and understands the warnings.
- Use your full attention while operating the machine. Do not engage in any activity that causes distractions; otherwise, injury or property damage may occur.
- Do not put your hands or feet near moving components of the machine.
- Do not operate the machine without all guards and other safety protective devices in place and working on the machine.
- Keep children, bystanders, and pets out of the operating area. Never allow children to operate the machine.
- Shut off the machine, remove the key (if equipped), and wait for all movement to stop before you leave the operator's position. Allow the machine to cool before adjusting, servicing, cleaning, or storing it.

Improperly using or maintaining this machine can result in injury. To reduce the potential for injury, comply with these safety instructions and always pay attention to the safety-alert symbol , which means Caution, Warning, or Danger—personal safety instruction. Failure to comply with these instructions may result in personal injury or death.

# Safety and Instructional Decals



Safety decals and instructions are easily visible to the operator and are located near any area of potential danger. Replace any decal that is damaged or missing.

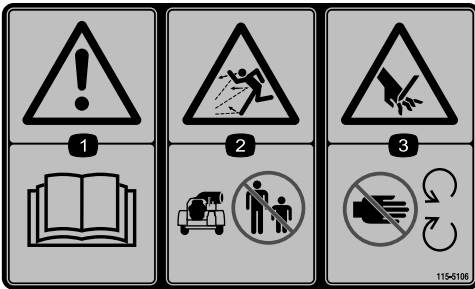

115-5106

decal115-5106

1. Warning—read the *Operator's Manual*.
2. Thrown object hazard—keep bystanders away.
3. Cutting/dismemberment hazard; hand—stay away from moving parts.

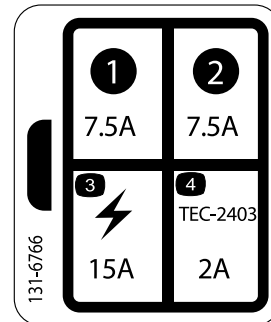

131-6766

decal131-6766

1. 7.5 A
2. 7.5 A
3. Electrical accessory (15 A)
4. TEC-2403 (2 A)

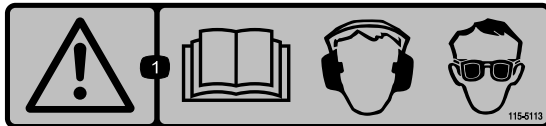

115-5113

decal115-5113

1. Warning—read the *Operator's Manual*; wear hearing and eye protection.



133-8062

decal133-8062

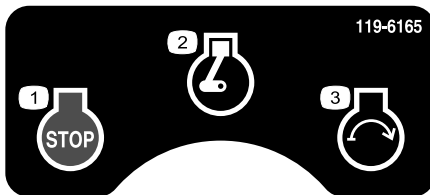

119-6165

decal119-6165

1. Engine—Stop
2. Engine—Run
3. Engine—Start



140-6767

decal140-6767

1. Warning—read the *Operator's Manual*.
2. Warning—all operators should be trained before operating the machine.
3. Warning—do not start the engine when the machine is disconnected from the tow vehicle; hitch the machine to the tow vehicle before starting the engine.
4. Thrown object hazard—keep bystanders away.
5. Warning—stay away from moving parts; keep all guards and shields in place.
6. Warning—shut off the engine, remove the key, and read the *Operator's Manual* before performing maintenance.

# Setup

## Loose Parts

Use the chart below to verify that all parts have been shipped.

Procedure	Description	Qty.	Use
<b>1</b>	Grafo 112X grease (Toro Part No. 505-47)	—	Connect the battery.
<b>2</b>	Debris blower assembly Hitch Bolt (3/8 x 3 inches) Flange nut (3/8 inch) Hitch clevis Bolt (5/8 x 4-1/2 inch) Locknut (5/8 inch)	1 1 2 2 1 2 2	Mount the hitch to the debris blower.
<b>3</b>	Hitch pin Clevis	1 1	Connect the blower to the tow vehicle.
<b>4</b>	Handheld remote AAA batteries	1 4	Assemble the handheld remote.

## Media and Additional Parts

Description	Qty.	Use
Operator's Manual	1	Read before operating.
Engine owner's manual	1	Use to reference the engine operation and maintenance.
Remote control	1	Use to remotely operate the blower.
Declaration of Conformity	1	For CE compliance.

**Note:** Determine the left and right sides of the machine from the normal operating position.

# 1

## Connecting the Battery

Parts needed for this procedure:

—	Grafo 112X grease (Toro Part No. 505-47)
---	--

## Procedure

1. Remove the 2 hairpins that secure the battery cover to the battery box, and remove the cover (Figure 3).

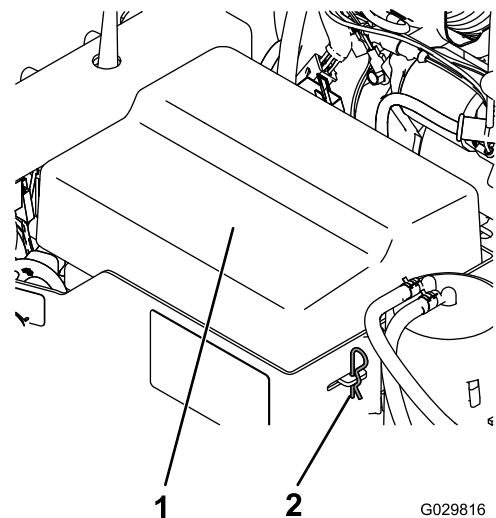

Figure 3

1. Battery cover
2. Battery clip

2. Assemble the positive cable (red) to the positive battery terminal, and tighten the T-bolt and nut.



3. Assemble the negative cable (black) to the negative battery terminal, and tighten the T-bolt and nut.
4. Coat the battery terminals with Grafo 112X (skin over) grease (Toro Part No. 505-47).
5. Slide the positive battery-cable insulator over the positive battery terminal.
6. Assemble the battery cover to the battery box, and secure the cover with the 2 hairpins (Figure 3).

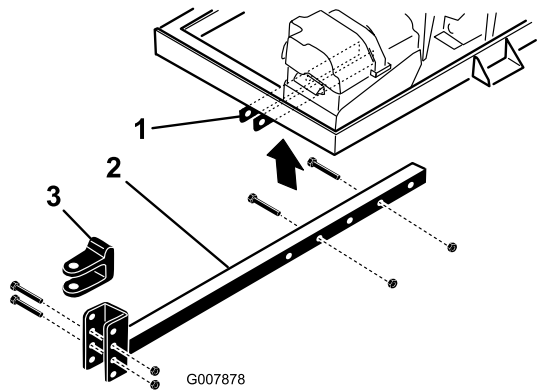

Figure 4

1. Frame brackets
  2. Hitch tube
  3. Hitch clevis
- 
4. Secure the hitch tube to the frame brackets (Figure 4) with 2 bolts (3/8 x 3 inches) and 2 flange nuts (3/8 inch).
  5. Torque the flange nut and bolts to 40 N·m (30 ft-lb).

# 2

## Mounting the Hitch to the Debris Blower

### Parts needed for this procedure:

1	Debris blower assembly
1	Hitch
2	Bolt (3/8 x 3 inches)
2	Flange nut (3/8 inch)
1	Hitch clevis
2	Bolt (5/8 x 4-1/2 inch)
2	Locknut (5/8 inch)

### Procedure

1. Position the debris blower on a flat, level surface, and chock the tires.
2. Raise the front of the machine and use jack stands to support it.
3. Insert the hitch tube into the frame brackets (Figure 4).

**Note:** You can rotate the hitch tube rotated 180° to accommodate different hitch heights.

**Important:** Install the hitch tube at the correct length so that the blower does not contact the tow vehicle while turning.

# 3

## Connecting the Debris Blower to the Tow Vehicle

### Parts needed for this procedure:

1	Hitch pin
1	Clevis

### Procedure

1. Back the tow vehicle up to the blower.
2. Support the hitch tube with a jack stand, and level the tube to the ground.
3. Remove the 2 bolts and 2 locknuts securing the hitch clevis (Figure 5) to the hitch tube.

# 4

## Installing the Batteries into the Handheld Remote

Parts needed for this procedure:

1	Handheld remote
4	AAA batteries

### Procedure

1. Remove the 6 screws securing the cover halves of the handheld remote together, and remove the back cover (Figure 7).

**Note:** If possible, leave the rubber seal and steel gasket in the channel when removing the cover.

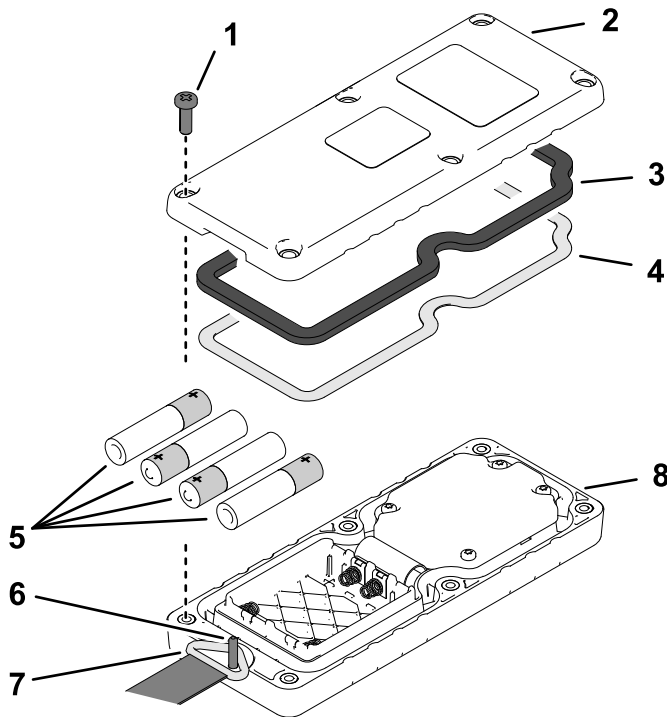

Figure 7

g341770

- |                 |                  |
|-----------------|------------------|
| 1. Screw        | 5. AAA batteries |
| 2. Back cover   | 6. Lanyard pin   |
| 3. Seal         | 7. Lanyard ring  |
| 4. Steel gasket | 8. Front cover   |

2. Observing battery polarity as shown in Figure 8, insert the new batteries into the terminal cradles.

**Note:** To avoid damaging the terminal cradles when installing batteries, observe proper polarity markings (Figure 8) that are embossed onto the

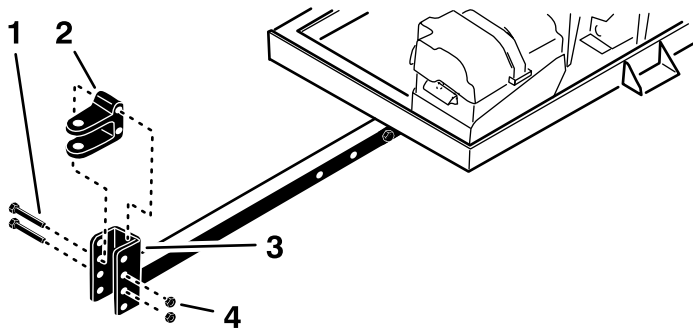

Figure 5

g341668

- |                 |               |
|-----------------|---------------|
| 1. Bolt         | 3. Hitch tube |
| 2. Hitch clevis | 4. Locknut    |

4. Raise or lower the hitch clevis to align it level with the hitch of the tow vehicle.

**Important:** Ensure that the debris blower frame is parallel with the ground.

5. Assemble the hitch clevis to the hitch tube with the 2 bolts and 2 locknuts (Figure 5).
6. Torque the locknuts and bolts to 203 N·m (150 ft-lb).
7. Connect the blower hitch clevis to the tow vehicle hitch with the hitch pin and lynch pin (Figure 6).

**Important:** If the blower contacts the tow vehicle when turning, extend the hitch tube away from the debris blower by assembling the hitch tube to the frame brackets using the furthest mounting holes; refer to [2 Mounting the Hitch to the Debris Blower](#) (page 9).

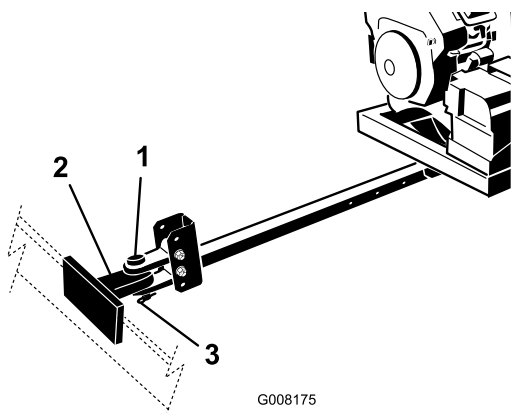

G008175

Figure 6

g008175

- |                      |              |
|----------------------|--------------|
| 1. Hitch pin         | 3. Lynch pin |
| 2. Tow vehicle hitch |              |

battery compartment. If you install the batteries improperly, you will not damage the machine, but the handheld remote will not operate.

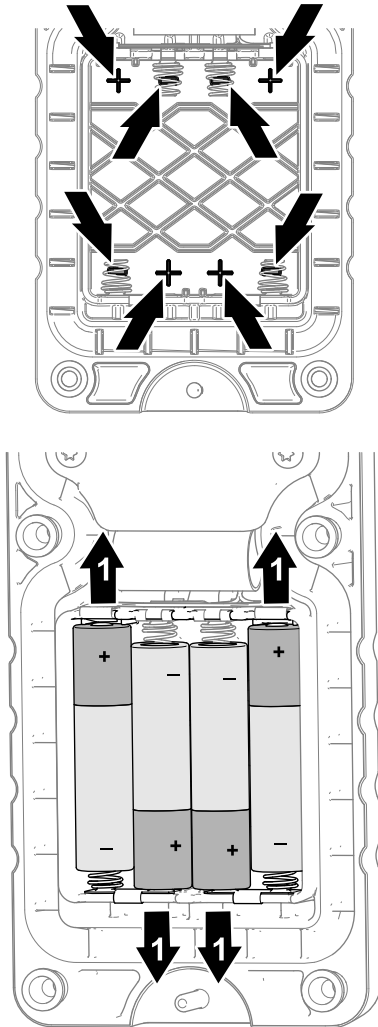

**Figure 8**

1. Positive battery polarity

3. Ensure that the steel gasket and rubber seal (Figure 7) are seated in the channel in the front cover half.
4. Align the lanyard ring over the lanyard pin (Figure 7).
5. Assemble the back cover to the and front cover with 6 screws (Figure 7).
6. Torque the screws to 1.5 to 1.7 N·m (13 to 15 in-lb).

# Product Overview

## Controls

### Handheld Remote

#### LED Light

The LED light indicates communication between the handheld remote communication and the wireless-control module (Figure 9).

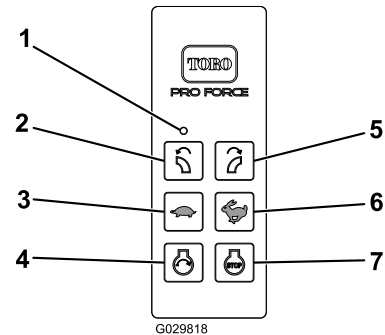

**Figure 9**

- |                                 |                                 |
|---------------------------------|---------------------------------|
| 1. LED light                    | 5. ROTATE NOZZLE RIGHT button   |
| 2. ROTATE NOZZLE LEFT button    | 6. INCREASE ENGINE SPEED button |
| 3. DECREASE ENGINE SPEED button | 7. ENGINE-STOP button           |
| 4. ENGINE-START button          |                                 |

#### Engine-Stop Button

Press the ENGINE-STOP button to shut off the engine (Figure 9).

#### Engine-Start Button

After preparing the machine for remote-control starting, press the ENGINE-START button to start the engine (Figure 9). Refer to [Running the Engine \(page 17\)](#) for the starting sequence.

#### Blower Nozzle-Direction Button

Press the ROTATE NOZZLE LEFT button or the ROTATE NOZZLE RIGHT button to rotate the blower nozzle to the desired direction (Figure 9).

#### Engine-Speed Button

- Press the INCREASE ENGINE SPEED button (rabbit icon) to increase the speed of the engine (Figure 9).

- Press DECREASE ENGINE SPEED button (turtle icon) to decrease the speed of the engine.
- Pressing the INCREASE ENGINE SPEED and DECREASE ENGINE SPEED buttons at the same time returns the engine to idle.

## Throttle Lever

Use the throttle lever to adjust the speed of the engine (Figure 10).

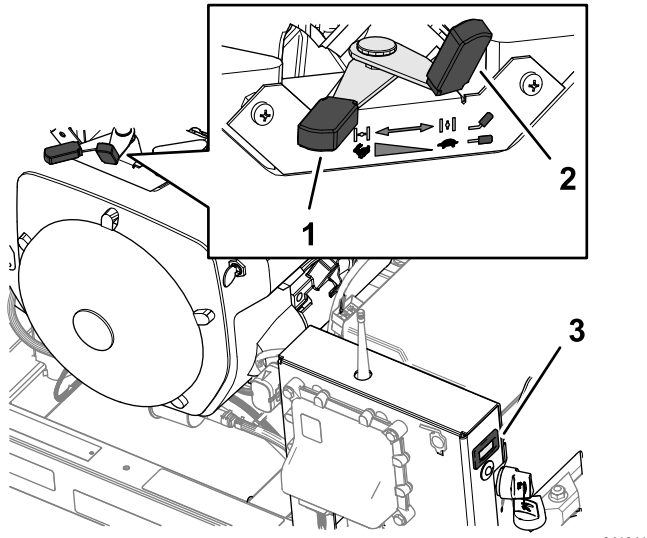

Figure 10

g341941

- |                   |               |
|-------------------|---------------|
| 1. Throttle lever | 3. Hour meter |
| 2. Choke lever    |               |

## Choke Lever

Use the choke lever to position the choke when starting a cold engine (Figure 10).

## Hour Meter

The hour meter (Figure 10) indicates the total hours of engine operation.

## Ignition Switch

Use the ignition switch (Figure 11), when starting and shutting off the engine at the control console. The ignition switch has 3 positions:

- STOP position
- RUN/ACCESSORY position
- START position

**Note:** Use the run/accessory position when controlling the machine with the handheld remote.

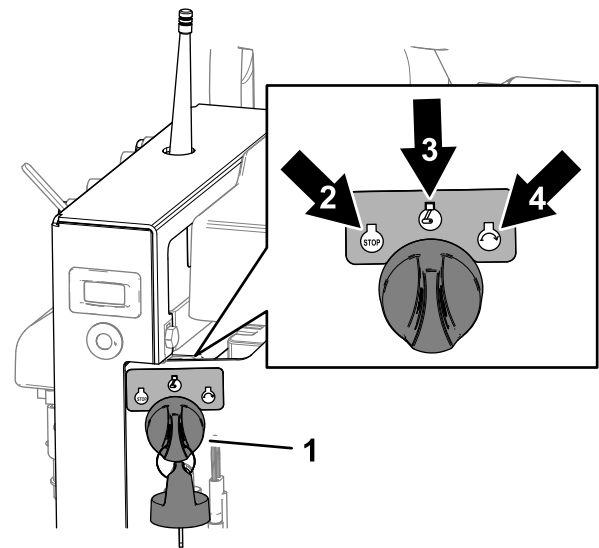

Figure 11

g341833

- |                  |                           |
|------------------|---------------------------|
| 1. Ignition key  | 3. RUN/ACCESSORY position |
| 2. STOP position | 4. START position         |

## Diagnostic Light

The diagnostic light (Figure 12) is located below the hour meter.

The diagnostic light indicates the status of the electronic system and the communication status with the handheld remote. The diagnostic light illuminates to indicate the following machine and handheld remote conditions:

- The electronic system of the machine starts normally.
- The wireless-control module cannot communicate with the handheld remote.
- The TEC controller detects an active fault.

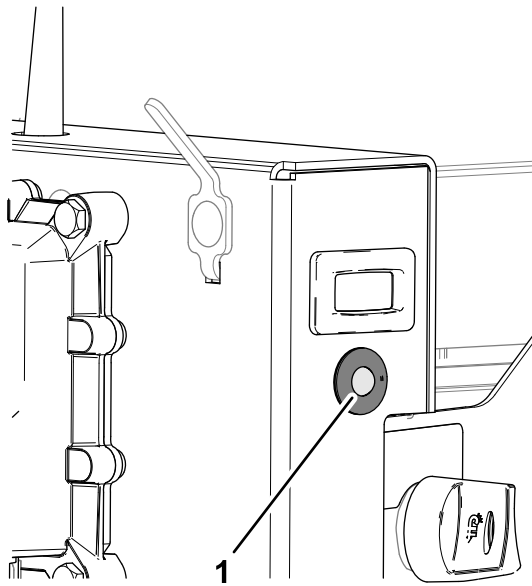

Figure 12

g342079

1. Diagnostic light

## Specifications

### Radio Specifications

Frequency	2.4 GHz
Max output power	19.59 dBm

### Attachments/Accessories

A selection of Toro approved attachments and accessories is available for use with the machine to enhance and expand its capabilities. Contact your Authorized Service Dealer or authorized Toro distributor or go to [www.Toro.com](http://www.Toro.com) for a list of all approved attachments and accessories.

To ensure optimum performance and continued safety certification of the machine, use only genuine Toro replacement parts and accessories. Replacement parts and accessories made by other manufacturers could be dangerous, and such use could void the product warranty.

## Operation

**Note:** Determine the left and right sides of the machine from the normal operating position.

### Before Operation

### Before Operation Safety

#### General Safety

- Never allow children or untrained people to operate or service the machine. Local regulations may restrict the age of the operator. The owner is responsible for training all operators and mechanics.
- Become familiar with the safe operation of the equipment, operator controls, and safety signs.
- Shut off the machine, remove the key (if equipped), and wait for all movement to stop before you leave the operator's position. Allow the machine to cool before adjusting, servicing, cleaning, or storing it. Know how to stop the machine and shut off the engine quickly.
- Keep all guards, safety devices, and decals in place. Repair or replace all safety devices and replace all illegible or missing decals. Do not operate the machine unless they are present and functioning properly.
- Ensure that the traction unit is suitable for use with an implement of this weight by checking with the traction unit supplier or manufacturer.
- Do not modify this equipment in any manner.

#### Fuel Safety

- Use extreme care in handling fuel. It is flammable and its vapors are explosive.
- Extinguish all cigarettes, cigars, pipes, and other sources of ignition.
- Use only an approved fuel container.
- Do not remove the fuel cap or fill the fuel tank while the engine is running or hot.
- Do not add or drain the fuel in an enclosed space.
- Do not store the machine or fuel container where there is an open flame, spark, or pilot light, such as on a water heater or other appliance.
- If you spill fuel, do not attempt to start the engine; avoid creating any source of ignition until the fuel vapors have dissipated.

# Fuel Specification

**Important:** Using unapproved fuel may cause performance problems and/or engine damage which may not be covered under warranty.

Type	
Minimum octane rating	87 (US) or 91 (research octane; outside the US)
Ethanol* content	No more than 10% by volume
Methanol content	None
MTBE* (methyl tertiary butyl ether) content	Less than 15% by volume
Oil	Do not add to the fuel
*Ethanol and MTBE are not the same.	

- Use only clean, fresh (no more than 30 days old), fuel from a reputable source.
- Do not store fuel either in the fuel tank or fuel containers over the winter unless a fuel stabilizer is used.

## Using Stabilizer/Conditioner

Use a fuel stabilizer/conditioner in the machine to provide the following benefits:

- Keeps fuel fresh longer when used as directed by the fuel-stabilizer manufacturer. For longer storage it is recommended that the fuel tank be drained.
- Cleans the engine while it runs
- Eliminates gum-like varnish buildup in the fuel system, which causes hard starting

**Important:** Do not use fuel additives containing methanol or ethanol.

Add the amount of fuel stabilizer/conditioner to fresh fuel as directed by the fuel-stabilizer manufacturer.

**Note:** A fuel stabilizer/conditioner is most effective when mixed with fresh fuel. To minimize the chance of varnish deposits in the fuel system, use fuel stabilizer at all times.

## Filling the Fuel Tank

**Fuel tank capacity:** 18.9 L (5 US gallons)

**Important:** Do not use fuel additives other than a fuel stabilizer/conditioner; refer to [Using Stabilizer/Conditioner \(page 14\)](#).

1. Shut the engine off.
2. Clean the area around the fuel-tank cap and remove the cap ([Figure 13](#)).

**Note:** The fuel tank cap contains a gauge which shows the fuel level.

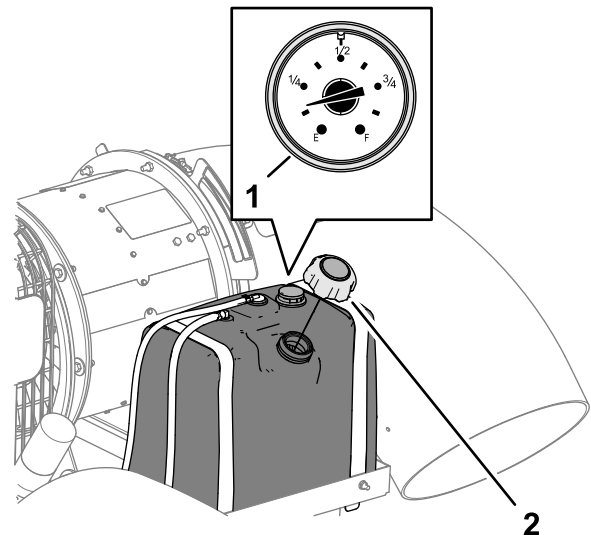

**Figure 13**

1. Fuel gauge
2. Fuel-tank cap

g341695

3. Add fuel to the fuel tank until the level is 6 mm to 13 mm (1/4 to 1/2 inch) below the bottom of the filler neck.

**Note:** This space in the tank allows fuel to expand. Do not fill the fuel tanks completely full.

4. Install fuel-tank cap securely ([Figure 13](#)).
5. Wipe up any spilled fuel.

## Performing Daily Maintenance

Before starting the machine each day, perform the Each Use/Daily procedures listed in [Maintenance \(page 22\)](#).

# ***During Operation***

## **During Operation Safety**

### **General Safety**

- The owner/operator can prevent and is responsible for accidents that may cause personal injury or property damage.
- Wear appropriate clothing, including eye protection; long pants; substantial, slip-resistant footwear; and hearing protection. Tie back long hair and do not loose clothing or loose jewelry.
- Do not operate the machine while ill, tired, or under the influence of alcohol or drugs.
- Use your full attention while operating the machine. Do not engage in any activity that causes distractions; otherwise, injury or property damage may occur.
- Discharged air has considerable force and could cause injury or loss of footing. Stay away from the blower nozzle when the machine is operating.
- Keep all bystanders away; shut off the machine when bystanders enter the area, do not direct discharge toward them.
- Do not operate the machine when it is not connected to a towing vehicle.
- Do not run the engine in or direct the blower nozzle into a confined area without adequate ventilation. Engine exhaust contains carbon monoxide, an odorless gas that is fatal if inhaled.
- Do not carry passengers on the machine and keep bystanders and pets away from the machine during operation.
- Operate the machine only in good visibility to avoid holes or hidden hazards.
- Look behind and down before backing up to be sure of a clear path.
- Use care when approaching blind corners, shrubs, trees, or other objects that may obscure your vision.
- Never run an engine in an area where exhaust gasses are enclosed.
- Never leave a running machine unattended.
- Before you leave the operator's position, do the following:
  - Park the machine on a level surface.
  - Engage the tow vehicle parking brake.
  - Shut off the engine and remove the key (if equipped).
  - Wait for all movement to stop.
- When transporting the machine on public roads, follow all traffic regulations and use any additional

accessories that may be required by law, such as lights, turn signals, slow-moving vehicle (SMV) signs, and others as required.

- If the machine ever vibrates abnormally, stop the machine immediately, shut off the engine, remove the key, wait for all moving parts to stop, and inspect for damage. Repair all damage to the machine before resuming operation.
- Reduce speed when operating on rough, uneven terrain, and near curbs, holes, and other sudden changes in terrain.
- To avoid causing the machine to tip over, be careful when turning and avoid unsafe maneuvers.

### **Slope Safety**

- Slopes are a major factor related to loss of control and rollover accidents, which can result in severe injury or death. You are responsible for safe slope operation. Operating the machine on any slope requires extra caution.
- Review the traction unit specifications to ensure that you do not exceed its slope capabilities.
- Evaluate the site conditions to determine if the slope is safe for machine operation, including surveying the site. Always use common sense and good judgment when performing this survey.
- Review the slope instructions, listed below, for operating the machine on slopes. Before you operate the machine, review the site conditions to determine whether you can operate the machine in the conditions on that day and at that site. Changes in the terrain can result in a change in slope operation for the machine.
  - Avoid starting, stopping, or turning the machine on slopes. Avoid making sudden changes in speed or direction. Make turns slowly and gradually.
  - Do not operate a machine under any conditions where traction, steering, or stability is in question.
  - Remove or mark obstructions such as ditches, holes, ruts, bumps, rocks, or other hidden hazards. Tall grass can hide obstructions. Uneven terrain could overturn the machine.
  - Be aware that operating the machine on wet grass, across slopes, or downhill may cause the machine to lose traction.
  - Use extreme caution when operating the machine near drop-offs, ditches, embankments, water hazards, or other hazards. The machine could suddenly roll over if a wheel goes over the edge or the edge caves in. Establish a safety area between the machine and any hazard.

# Diagnostic Light

The diagnostic light (Figure 14) indicates the status of the electronic system and the communication status with the handheld remote.

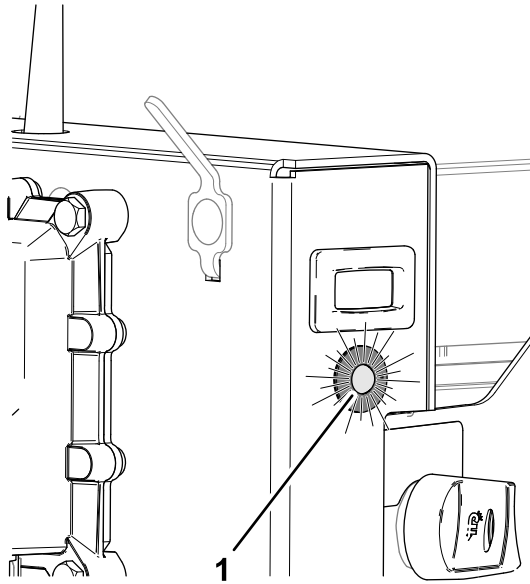

Figure 14

g342080

1. Diagnostic light

## System Startup Flash Code

The system startup flash code runs each time the electronic system of the machine starts normally.

The system startup flash code displays when you turn the ignition key to the RUN position and the diagnostic light flashes in the following pattern:

- The light illuminates for 5 seconds.
- The light shuts off for 5 seconds.
- The light flashes 3 times a second until you push a button on the handheld remote.

## Broken Communication Flash Code

The broken communication flash code runs when the wireless-control module cannot communicate with the handheld remote.

The broken communication flash code displays when you turn the ignition key to the RUN position and the diagnostic light flashes rapidly.

Possible handheld-remote communication issues include:

- The wireless-control module has not received a handheld-remote signal within 10 seconds of turning the ignition key to the RUN position.
- The handheld remote is too far from the machine.

- The handheld remote has low battery power.
- The wireless-control module is not associated with a handheld remote.

## Active Fault Flash Code

The active fault flash code runs when the TEC controller detects an active fault.

The active fault flash code displays when you turn the ignition key to the RUN position and the diagnostic light flashes in the following pattern:

- The light illuminates for 5 seconds.
- The light flashes rapidly (with or without a pause).

## Starting the Engine At the Control Console

### ⚠ CAUTION

Starting the engine starts the machine immediately, blowing debris, sand, and dust, which could injure bystanders.

- Keep all bystanders away from the operating area.
- Shut off the machine when bystanders enter the area.

1. Ensure that the blower is securely attached to the tow vehicle before you start the engine.
2. If the engine is cold, move the choke lever (Figure 15) to the ON position.

**Note:** A warm or hot engine may not require using the choke. After the engine starts, move the choke control to the OFF position.

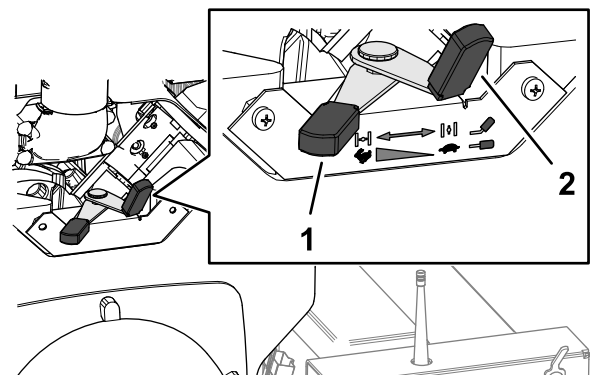

Figure 15

g341942

1. Choke lever
2. Throttle lever

3. Move the throttle lever (Figure 15) midway between slow and fast positions.



4. Rotate the ignition switch to the START position.

**Important:** Do not hold the ignition key in the start position for more than 10 seconds at a time. If engine does not start, wait 10 seconds for the starter to cool-down between starting attempts. If you do not allow the starter motor to cool down between attempts, you could damage the starter.

5. When the engine starts, release the ignition key.
6. If the choke lever is in the ON position, gradually move the lever to the OFF position as the engine warms.

## Shutting Off the Engine

### At the Control Console

1. Move the throttle lever to the 3/4 throttle position.
2. Rotate the ignition switch to the STOP position.

## Using the Remote Control

The handheld remote activates when you press any button. To conserve battery power, the handheld remote stays active for 3 seconds before automatically shutting off, unless you press a button within that time. When the handheld remote times out and powers down, the remote control LED activity stops (Figure 16). Pressing any button activates the remote control.

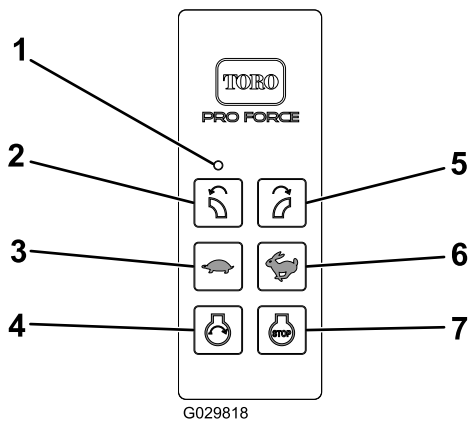

Figure 16

- |                                 |                                 |
|---------------------------------|---------------------------------|
| 1. LED light                    | 5. ROTATE NOZZLE RIGHT button   |
| 2. ROTATE NOZZLE LEFT button    | 6. INCREASE ENGINE SPEED button |
| 3. DECREASE ENGINE SPEED button | 7. ENGINE-STOP button           |
| 4. ENGINE-START button          |                                 |

more than 2.5 hours without communication from the handheld remote. The power-save mode is a low-current state of the wireless-control module. In the power-save mode, the wireless-control module does not communicate with the handheld remote, activate outputs, or function as normal.

- When in the time-out mode, the engine does not run (or shuts off), and the handheld remote does not control any function.
- To wake the wireless-control module from time-out mode, turn the key switch to the OFF position and then turn the key switch to the RUN position.
- To avoid wireless-control module time-out during operation, use the handheld remote to rotate the blower nozzle or change the engine speed every 2.5 hours or more often.

## Running the Engine

### Using the Handheld Remote

#### ⚠ WARNING

Rotating parts can cause serious personal injury.

- Keep your hands, feet, hair, and clothing away from all moving parts to prevent injury.
- Never operate the machine with covers, shrouds, or guards removed.

1. Prepare the machine; refer to [Preparing the Machine](#) (page 17).
2. Perform the start enable sequence; refer to [Performing the Start-Enable Sequence](#) (page 18).
3. Start the engine with the handheld remote; refer to [Starting the Engine](#) (page 18).

## Preparing the Machine

1. Ensure that the blower is securely attached to the tow vehicle before you start the engine of the blower.
2. Before starting a cold engine, move the choke lever (Figure 17) to the ON position.

**Note:** A warm or hot engine may not require using the choke. After the engine starts, move the choke control to the OFF position.

The wireless-control module and TEC controller revert to power-save mode (until a power cycle occurs) if the wireless-control module is inactive for

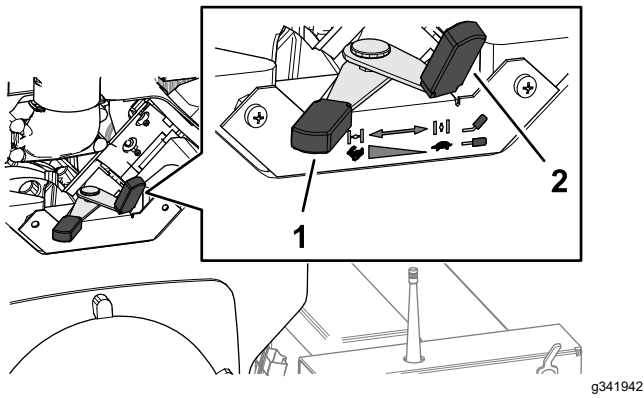

Figure 17

1. Choke lever
2. Throttle lever

3. Rotate the engine ignition key to the RUN/ACCESSORY position.

**Note:** If the key was left in the RUN position for an extended time, move the key to the OFF position before starting the engine.

4. Perform the start-enable sequence; refer to [Performing the Start-Enable Sequence \(page 18\)](#).

## Performing the Start-Enable Sequence

Before you can start the engine with the handheld remote, you must activate the engine start-enable condition as follows:

1. Press the START button ([Figure 18](#)) on the handheld remote.

**Note:** There is a time limit of 3 seconds between pressing each button. If the next button in the sequence is not pressed within 3 seconds of the last button press, the sequence automatically ends, and you must start the start-enable sequence again.

**Note:** If you press any button other than the next appropriate button in the sequence, the start-enable sequence automatically ends.

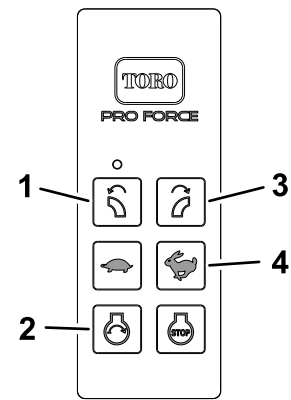

Figure 18

1. ROTATE NOZZLE LEFT button
2. ENGINE-START button
3. ROTATE NOZZLE RIGHT button
4. INCREASE ENGINE SPEED button

2. Press the ROTATE NOZZLE LEFT button.
3. Press the ROTATE NOZZLE RIGHT button.

**Note:** You must press the ENGINE-START button within 10 seconds after pressing the ROTATE NOZZLE RIGHT button to start the engine; refer to [Starting the Engine \(page 18\)](#).

## Starting the Engine

### ⚠ CAUTION

**Starting the engine starts the machine immediately, blowing debris, sand, and dust, which could injure bystanders.**

- **Keep all bystanders away from the operating area.**
- **Shut off the machine when bystanders enter the area.**

1. Press and hold the ENGINE-START button ([Figure 19](#)) on the handheld remote until the engine starts.

**Important:** Do not press and hold the ENGINE-START button for more than 10 seconds at a time. If engine fails to start, wait 10 seconds for the starter to cool down between starting attempts. If you do not allow the starter motor to cool down between attempts, you could damage the starter.

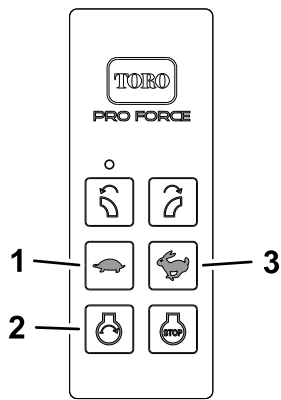

Figure 19

g343720

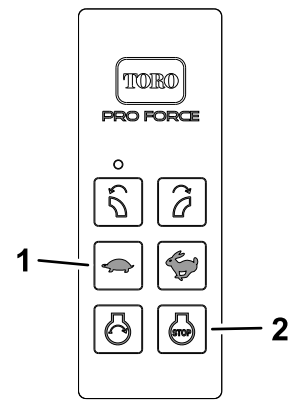

Figure 20

g343719

1. DECREASE ENGINE SPEED button
2. ENGINE-START button
3. INCREASE ENGINE SPEED button

1. DECREASE ENGINE SPEED button
2. ENGINE-STOP button

2. If the choke lever is in the ON position, move the lever to the OFF position as the engine warms.

**Note:** If the engine stalls or hesitates, move the choke toward the ON position for a few seconds, then set the engine speed to the desired setting. Repeat this as required.

3. Adjust the engine speed using the handheld remote by pressing the INCREASE ENGINE SPEED button or DECREASE ENGINE SPEED button (Figure 19).

2. Press the ENGINE-STOP button (Figure 20).
3. If you leave the machine, rotate the ignition key to the OFF position and remove the key from the control console.

## Adjusting the Blower Nozzle Direction

Rotate the blower nozzle left or right by pressing the ROTATE NOZZLE LEFT button or the ROTATE NOZZLE RIGHT button on the remote control (Figure 21).

## Engine Start-Enable Condition Tips

- Pressing the ENGINE-START button does not extend the time allowance.

**Note:** The start-relay control is active 10 seconds after pressing the ROTATE NOZZLE RIGHT button.

- If the engine start enable condition times-out, you must perform the engine start enable sequence again to start the engine with the handheld remote.

**Note:** You must wait 10 seconds after releasing the ENGINE-START button before attempting the start-enable sequence again.

- If you quit performing the start-enable sequence or the engine start enable condition times-out, the handheld remote returns to control of the ROTATE NOZZLE LEFT and ROTATE NOZZLE RIGHT buttons for the nozzle position.

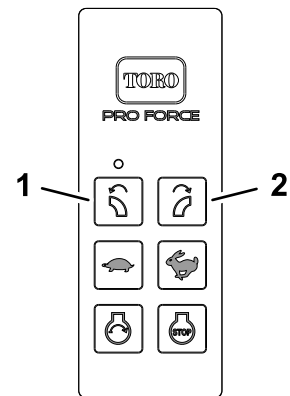

Figure 21

g343715

1. ROTATE NOZZLE LEFT button
2. ROTATE NOZZLE RIGHT button

## Moving the Machine from the Job Site

**Important:** Raise the blower nozzle before moving the machine from the job site. If you leave the blower nozzle in the down position during transport, the nozzle may contact the ground, and become damaged.

## Shutting Off the Engine

1. Press the DECREASE-ENGINE SPEED button (Figure 20) on the handheld remote to slow engine speed (about 3/4 throttle).

# The Nozzle-Position Gauge

The nozzle-position gauge (Figure 22) is located behind the turbine housing, above the fuel tank.

**Note:** The decal on the nozzle-position gauge indicates the position of the nozzle relative to the ground.

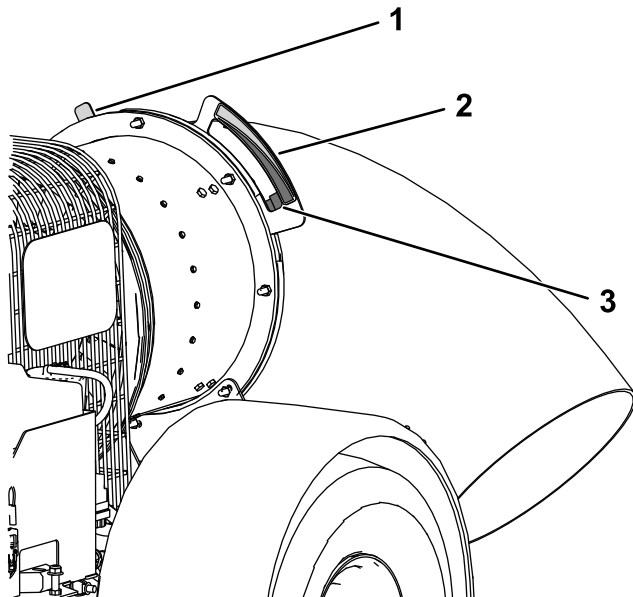

g314786

**Figure 22**

Some parts hidden for clarity.

1. Red pointer
2. Nozzle-position gauge and decal
3. Green pointer (shown in the window of the nozzle-position gauge window—left aligned blower nozzle)

There is a red pointer and a green pointer (Figure 22) attached to the blower nozzle.

## Nozzle Alignment

- When the red pointer is visible in the nozzle position gauge, the blower nozzle is aligned to blow to the right of the machine.
- When the green pointer is visible in the nozzle position gauge, the blower nozzle is aligned to blow to the left of the machine.

## Nozzle Angle

The pointer and gauge indicate the blower nozzle angle as follows:

- When the pointer is in the same colored region on the decal, that indicates that the chute opening is positioned more parallel to the ground.
- When a pointer tab is in the different colored region on the decal, that indicates that the chute opening is positioned more toward the ground.

# Operating the Optional Lights

1. If the engine is not running, rotate the ignition key to the RUN/ACCESSORY position.
2. To switch the light ON or OFF, press the handheld remote buttons (Figure 23) in the following sequence:
  - A. ENGINE-START button
  - B. DECREASE ENGINE SPEED button

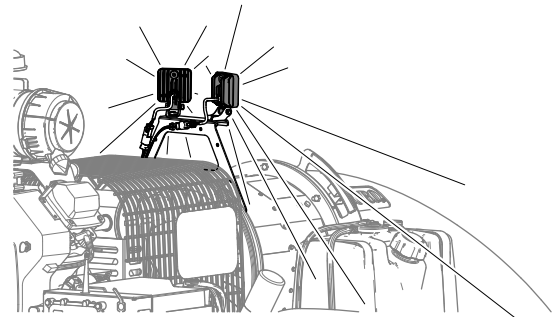

g342134

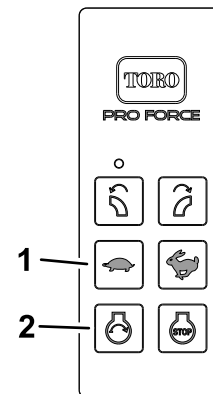

**Figure 23**

g343717

1. DECREASE ENGINE SPEED
2. ENGINE-START button

## Operating Tips

- Practice operating the blower. Blow the same direction that the wind blows to prevent material from blowing back into the cleared area.
- When blowing debris from a job site, run the engine at full throttle.
- Adjust the blower nozzle position so that the airstream blows under the debris.
- Use caution when blowing around newly planted sod; the airstream could disrupt the grass.

## After Operation

### After Operation Safety

#### General Safety

- Park the machine on a firm, level surface; shut off the engine, remove the key, wait for all moving parts to stop, and allow the machine to cool before adjusting, repairing, cleaning, or storing the machine.
- Only disconnect the machine from the traction unit while on a level surface.
- When disconnecting the machine, always chock the wheels to prevent movement.
- Do not store the machine or fuel container where there is an open flame, spark, or pilot light, such as on a water heater or other appliance.
- Keep all parts of the machine in good working condition and all hardware tightened.
- Replace all worn, damaged, or missing decals.

#### Towing Safety

- Before towing the machine, check with your local county or state safety towing regulations, in addition to meeting Department of Transportation (DOT) Safety Towing Regulations.
- Always shut off the engine and point the blower nozzle up before transporting.
- Tow only with a machine that has a hitch designed for towing. Do not attach towed equipment except at the hitch point.
- Always inspect the hitch and coupling for wear. Do not tow the machine with damaged or missing hitches, couplings, or chains.
- Check the tire air pressure on the machine. The tires should be inflated to 241 kpa (35 psi) cold. Also, check the tire-tread wear on the machine.
- Always properly attach the machine safety chains to the towing vehicle.

- Do not tow the machine faster than 88 km/h (55 mph). Recommended off-road towing is not to exceed 24 km/h (15 mph).
- Avoid sudden stops and starts. This can cause skidding or jack knifing. Smooth, gradual starts and stops will improve towing.
- Avoid sharp turns to prevent rolling.
- Chock the wheels to while parked to prevent movement.

## Remote Control Operation

- Failure to abide by the safety precautions may result in equipment failure, loss of authority to operate the equipment, and personal injury.
- Use and maintain the proper wiring. Follow the equipment manufacturer instructions. Improper, loose, and frayed wiring can cause system failure, equipment damage, and intermittent operation.
- Changes or modifications made to the machine that are not expressly approved by the manufacturer will void the warranty.
- The machine owner and operators must abide by all applicable federal, state, and local laws concerning machine installation and operation. Failure to comply could result in penalties and could void the user's authority to operate the machine.
- Ensure that the machinery and surrounding area is clear before operating. Do not activate the remote control system until you are certain that it is safe to do so.
- Use a damp cloth to keep the remote clean. Remove mud, concrete, and dirt after operation to prevent obstructing or clogging the buttons, levers, wiring, and switches.
- Do not allow liquid to enter the remote control or base-unit enclosures. Do not use high-pressure equipment to clean the remote control or base unit.
- Operate and store the machine only within the specified operation and storage temperatures.

## Hauling

- Use care when loading or unloading the machine into a trailer or truck.
- Use full-width ramps for loading machine into trailer or truck.
- Tie the machine down securely using straps, chains, cable, or ropes. Both front and rear straps should be directed down and outward from the machine.

# Maintenance

**Note:** Determine the left and right sides of the machine from the normal operating position.

**Note:** Download a free copy of the electrical or hydraulic schematic by visiting [www.Toro.com](http://www.Toro.com) and searching for your machine from the Manuals link on the home page.

## Maintenance Safety

- Before cleaning, servicing, or adjusting the machine, do the following:
  - Park the machine on a level surface.
  - Shut off the engine, remove the key, disconnect the spark-plug wire, and wait for all moving parts to stop.
  - Chock the wheels.
  - Remove the machine from the traction unit.
  - Allow machine components to cool before performing maintenance.
- Perform only those maintenance instructions described in this manual. If major repairs are ever needed or you need assistance, contact an authorized Toro distributor.
- Support the machine with blocks or jack stands when working beneath it.
- Ensure that all guards are installed securely after maintaining or adjusting the machine.
- Do not allow untrained personnel to service the machine.
- Use jack stands to support the machine or components when required.
- Carefully release pressure from components with stored energy.
- Do not charge the batteries while servicing the machine.
- To reduce the potential fire hazard, keep the engine area free of excessive grease, grass, leaves, and accumulation of dirt.
- If possible, do not perform maintenance while the engine is running. Keep away from moving parts.
- If you must run the engine to perform a maintenance adjustment, keep your hands, feet, clothing, and all other parts of your body away from the engine and any moving parts. Keep bystanders away from the machine.
- Clean up oil and fuel spills.
- Keep all parts in good working condition and all fasteners tightened. Replace all damaged or missing decals.
- Do not interfere with the intended function of a safety device or reduce the protection provided by a safety device. Check their proper operation regularly.
- Do not overspeed the engine by changing the governor settings. To ensure safety and accuracy, have an authorized Toro distributor to check the maximum engine speed with a tachometer.
- If major repairs are ever necessary or assistance is required, contact an authorized Toro distributor.
- Altering this machine in any manner may affect the operation of the machine, performance, durability, or its use may result in injury or death. Such use could void the product warranty of The Toro® Company.

# Recommended Maintenance Schedule(s)

Maintenance Service Interval	Maintenance Procedure
After the first 8 hours	<ul style="list-style-type: none"> <li>• Check the condition and the tension of the belt.</li> </ul>
After the first 10 hours	<ul style="list-style-type: none"> <li>• Check the torque of the wheel lug nuts.</li> </ul>
Before each use or daily	<ul style="list-style-type: none"> <li>• Check the engine oil level.</li> <li>• Clean the engine screen and the oil cooler.</li> <li>• Check the tire air pressure.</li> <li>• Check the blower nozzle clamp.</li> <li>• Clean the nozzle guides.</li> </ul>
Every 25 hours	<ul style="list-style-type: none"> <li>• Clean the foam air filter element and check the paper element for damage (more frequently in dusty or sandy conditions).</li> </ul>
Every 50 hours	<ul style="list-style-type: none"> <li>• Check the condition and the tension of the belt.</li> </ul>
Every 100 hours	<ul style="list-style-type: none"> <li>• Replace the paper air filter element (more frequently in dusty or sandy conditions).</li> <li>• Change the engine oil. Change the oil more frequently when the operating in dusty or sandy conditions.</li> <li>• Check the condition of the tires.</li> </ul>
Every 200 hours	<ul style="list-style-type: none"> <li>• Replace the oil filter. Change the oil filter more frequently when the operating in dusty or sandy conditions.</li> <li>• Check the spark plugs.</li> <li>• Replace the carbon-canister air filter (Service more frequently in dusty or sandy conditions).</li> <li>• Replace the carbon-canister purge-line filter.</li> </ul>
Every 500 hours	<ul style="list-style-type: none"> <li>• Replace the fuel filter.</li> </ul>

**Important:** Refer to your engine owner's manual for additional maintenance procedures.

# Daily Maintenance Checklist

Duplicate this page for routine use.

Maintenance Check Item	For the week of:						
	Mon.	Tues.	Wed.	Thurs.	Fri.	Sat.	Sun.
Check the engine oil level.							
Clean the engine screen and the oil cooler.							
Inspect the air filter pre-cleaner.							
Check the tire air pressure.							
Check blower nozzle mounting clamp torque							
Clean the nozzle guides.							
Check any unusual engine noises.							
Check for fluid leaks.							
Touch-up damaged paint.							

Notation for Areas of Concern		
Inspection performed by:		
Item	Date	Information



# Pre-Maintenance Procedures

## ⚠ CAUTION

Failure to properly maintain the machine could result in premature failure of machine systems causing possible harm to you or bystanders.

Keep the machine well maintained and in good working order as indicated in these instructions.

## ⚠ WARNING

If you leave the key in the ignition switch, someone could accidentally start the engine and seriously injure you or other bystanders.

Remove the key from the ignition and disconnect the wires from the spark plugs before you do any maintenance. Set the wires aside so that they do not accidentally contact the spark plugs.

## Preparing for Machine

1. Park the machine on a level surface.
2. Shut off the engine, remove the key, and wait for all moving parts to stop.
3. Chock the wheels.
4. Remove the machine from the traction unit.
5. Allow machine components to cool before performing maintenance.
6. Disconnect the spark-plug wire.

## Preparing the Machine for Weld Repairs

**Important:** Failure to disconnect the battery may permanently damage to the wireless-control module and the TEC controller.

- Disconnect the negative-battery cable from the battery before welding on the machine.
- Connect the negative-battery cable to the battery after you finish welding on the machine.

# Engine Maintenance

## Engine Safety

- Shut off the engine before checking the oil or adding oil to the crankcase.
- Do not change the governor speed or overspeed the engine.

## Servicing the Air Cleaner

**Service Interval:** Every 25 hours—Clean the foam air filter element and check the paper element for damage (more frequently in dusty or sandy conditions).

Every 100 hours—Replace the paper air filter element (more frequently in dusty or sandy conditions).

## Checking the Air Filter

1. Prepare the machine for maintenance; refer to [Preparing for Machine \(page 25\)](#).
2. Check the air cleaner body for damage, which could possibly cause an air leak. Ensure the cover is sealing around the air cleaner body ([Figure 24](#)).

**Note:** Replace a damaged air cleaner cover or housing.

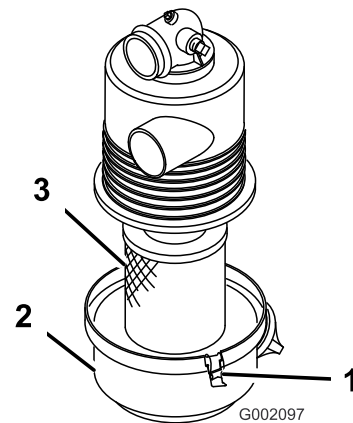

Figure 24

1. Air-filter housing
2. Air-filter element
3. Air-filter cover

3. Release the latches securing the air-filter cover to the air-filter housing ([Figure 24](#)).
4. Separate the air-filter cover from the air-filter housing, and clean the inside of the cover ([Figure 24](#)).
5. Gently slide the air-filter element out of the filter housing.

**Note:** To reduce the amount of dust dislodged, avoid knocking the filter against the air-filter housing.

6. Inspect the air-filter element.

**Note:** Check the sealing end of the filter.

**Important:** Replace a damaged filter.

- If the air-filter element is clean, install the filter element; refer to [Installing the Air Filter \(page 26\)](#).
- If the air-filter element is damaged, replace the filter element; refer to [Replacing the Air Filter \(page 26\)](#) and [Installing the Air Filter \(page 26\)](#).

## Replacing the Air Filter

1. Clean the dirt ejection port located on the air-filter cover.
2. Remove the rubber outlet valve from the cover, clean the cavity, and replace the outlet valve.
3. Release the latches securing the air-filter cover to the air-filter housing, and remove the cover ([Figure 25](#)).

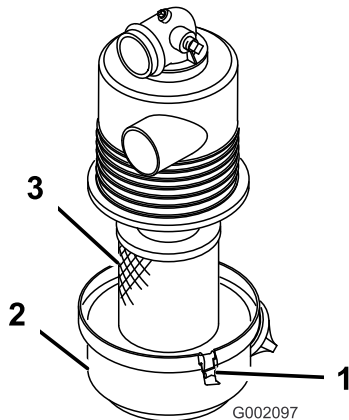

**Figure 25**

1. Air-filter housing
2. Air-filter element
3. Air-filter cover

4. Gently slide the air-filter element ([Figure 25](#)) out of the filter housing.

**Note:** To reduce the amount of dust dislodged, avoid knocking the filter against the air-filter housing.

5. Inspect the new filter for shipping damage.

**Note:** Check the sealing end of the filter.

**Important:** Do not install a damaged filter.

## Installing the Air Filter

**Important:** To prevent engine damage, always operate the engine with the complete air-cleaner assembly installed.

**Important:** Do not use a damaged element.

**Note:** Cleaning of the used air-filter element is not recommended due to the possibility of damage to the filter media.

1. Clean the dirt ejection port located on the air-filter cover.
2. Remove the rubber outlet valve from the cover, clean the cavity, and replace the outlet valve.
3. Insert the air-filter element into air-filter housing ([Figure 26](#)).

**Note:** Ensure that the filter is sealed properly by applying pressure to the outer rim of the filter when installing it. Do not press on the flexible center of the filter.

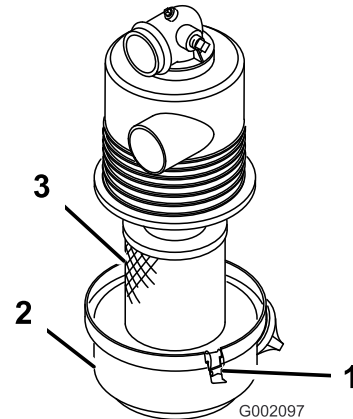

**Figure 26**

1. Air-filter housing
2. Air-filter element
3. Air-filter cover

4. Align the air-cleaner cover with the air-cleaner housing, and secure the cover to the housing with the latches ([Figure 26](#)).

# Engine Oil Specification

**Oil Type:** Detergent oil (API service SJ or higher)

**Oil Viscosity:** Refer to the table below that follows:

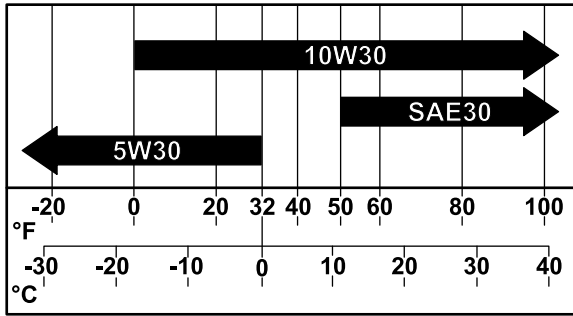

Figure 27

g341978

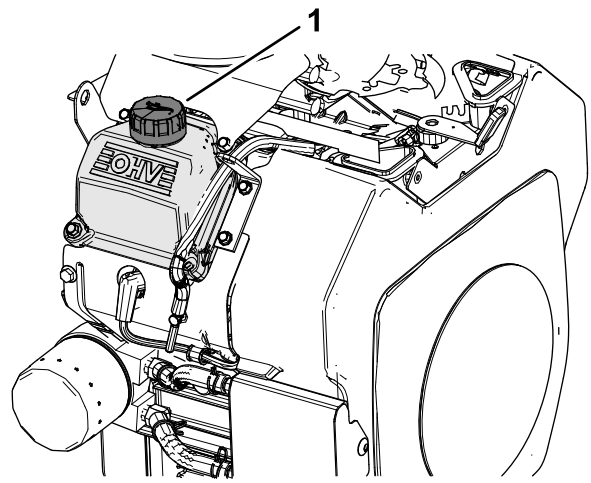

Figure 29

g341990

## Checking the Engine-Oil Level

**Service Interval:** Before each use or daily

**Note:** The best time to check the engine-oil level is when the engine is cool before it has been started for the day. If it has already been run, wait at least 10 minutes before checking the oil level.

1. Prepare the machine for maintenance; refer to [Preparing for Machine](#) (page 25).
2. Clean the area around the oil dipstick and the oil-fill cap of the valve cover ([Figure 28](#) and [Figure 29](#)).

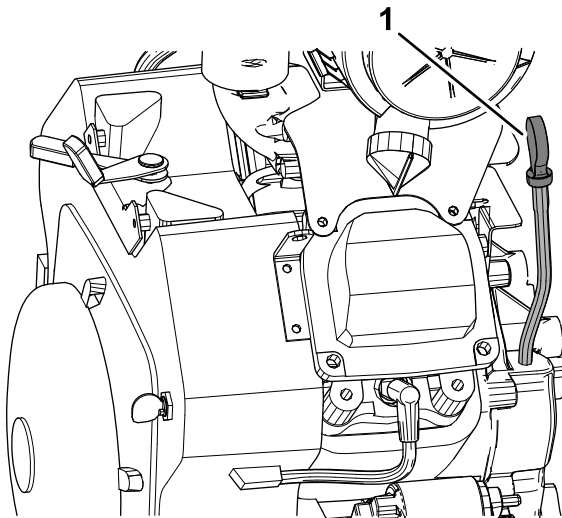

Figure 28

g341987

1. Dipstick

1. Oil-fill cap (valve cover)

3. Remove the dipstick and wipe the end clean ([Figure 28](#)).
4. Insert the dipstick fully into the dipstick tube ([Figure 30](#)).
5. Pull the dipstick out and look at the metal end.

**Note:** The oil level should be at the top-indicator mark on the dipstick.

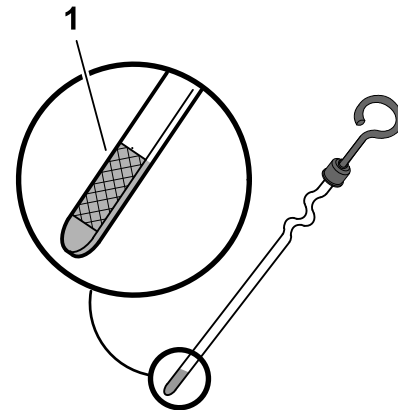

Figure 30

g341993

1. Oil-level range (dipstick)

6. If the oil level is below the top-indicator mark on the dipstick, remove the oil-fill cap, slowly add the specified oil to bring the oil level to the top-indicator mark, and install the oil-fill cap; refer to [Engine Oil Specification](#) (page 27).

**Important:** Do not overfill the crankcase with oil and run the engine. Engine damage may result.

7. Insert the dipstick fully into the dipstick tube.

# Changing the Oil

**Service Interval:** Every 100 hours Change the oil more frequently when the operating in dusty or sandy conditions.

**Crankcase capacity:** 2 L (67 oz)—with the filter

1. Start the engine and let it run 5 minutes.

**Note:** Warm oil drains better.

2. Park the machine so that the drain side is slightly lower than the opposite side to ensure the oil drains completely.
3. Shut off the engine, remove the key, and wait for all moving parts to stop before leaving the operator's position.
4. Place a pan below the drain. Rotate the oil-drain valve to allow the oil to drain ([Figure 31](#)).

**Note:** You may slip a hose onto the drain valve to help direct the oil flow. The hose is not included with the machine.

5. When the oil has drained completely, close the drain valve.

**Note:** Dispose of the used oil at a recycling center.

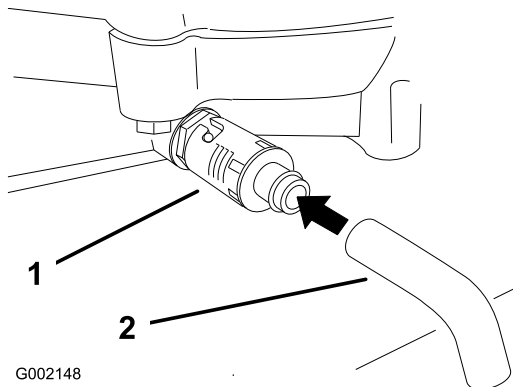

**Figure 31**

1. Oil-drain valve
2. Oil-drain hose (**not included**)

6. Slowly pour approximately 80% of the specified oil into the filler neck ([Figure 32](#)) of the valve cover; refer to [Engine Oil Specification \(page 27\)](#).

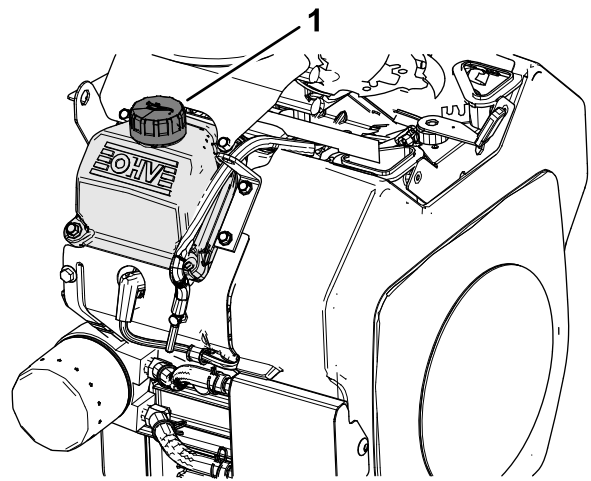

**Figure 32**

1. Oil-fill cap (valve cover)

7. Check the oil level; refer to [Checking the Engine-Oil Level \(page 27\)](#).
8. Slowly add the additional oil to bring oil level up to the top-indicator mark on the dipstick.

# Changing the Oil Filter

**Service Interval:** Every 200 hours Change the oil filter more frequently when the operating in dusty or sandy conditions.

**Crankcase capacity:** 2 L (67 oz)—with the filter

1. Drain the oil from the engine; refer to [Changing the Oil \(page 28\)](#).
2. Remove the old filter and wipe the filler adapter gasket surface ([Figure 33](#)).

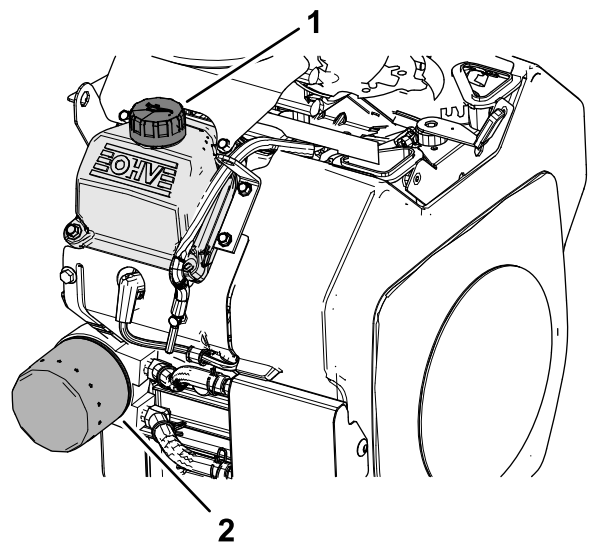

**Figure 33**

1. Oil-fill cap (valve cover)
2. Oil filter

- Apply a thin coat of new oil to the rubber gasket on the replacement filter ([Figure 33](#)).
- Install the replacement oil filter to the filter adapter, turn the oil filter clockwise until the rubber gasket contacts the filter adapter, then tighten the filter an additional 2/3 to 1 turn ([Figure 34](#)).

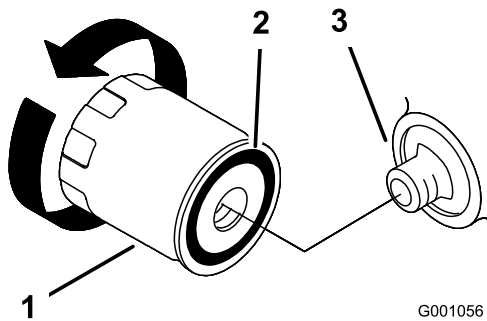

**Figure 34**

- |                   |            |
|-------------------|------------|
| 1. Oil filter     | 3. Adapter |
| 2. Adapter gasket |            |

- Remove the oil-fill cap ([Figure 33](#)) and add 2 L (67 oz) of the specified oil into the engine; refer to [Engine Oil Specification \(page 27\)](#) and [Changing the Oil \(page 28\)](#).
- Run the engine for about 3 minutes, shut off the engine, and check for oil leaks around the oil filter.
- Check the engine oil level and add the specified oil if needed.

## Servicing the Spark Plugs

**Spark plug type:** Champion® RC12YC, Champion® Platinum 3071 or equivalent

**Air gap:** 0.76 mm (0.030 inch)

## Checking the Spark Plugs

**Service Interval:** Every 200 hours

- Prepare the machine for maintenance; refer to [Preparing for Machine \(page 25\)](#).
- Clean the area around the spark plugs ([Figure 35](#)).

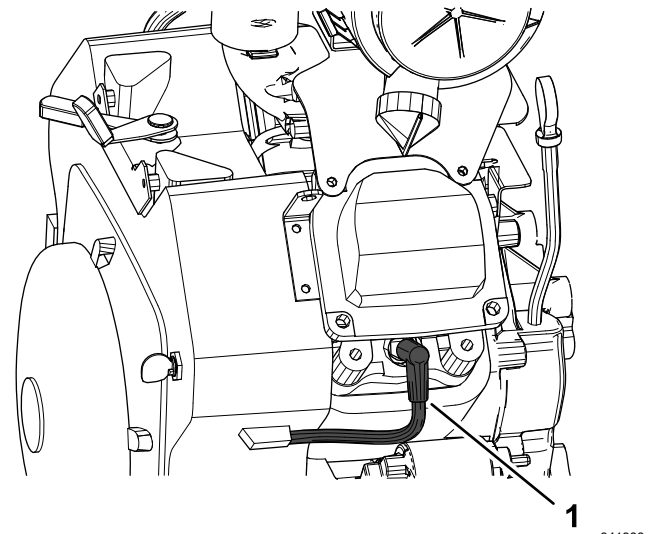
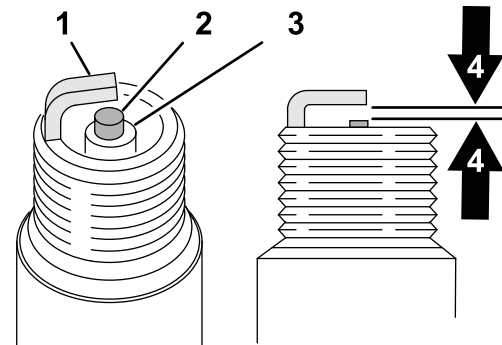

**Figure 35**

- Spark-plug wire

- Disconnect the spark-plug wires from the spark plugs ([Figure 35](#)).
- Remove the spark plug and gasket using a spark-plug socket.
- Look at the center of the spark plugs ([Figure 36](#)). If you see light brown or gray on the insulator, the engine is operating properly. A black coating on the insulator usually means that the air cleaner is dirty.

**Note:** If the spark plug is damaged or worn, install a new spark plug.



**Figure 36**

- |                     |                                 |
|---------------------|---------------------------------|
| 1. Side electrode   | 3. Insulator                    |
| 2. Center electrode | 4. Air gap 0.75 mm (0.030 inch) |

**Important:** Always replace a spark plug when it has a black coating, worn electrodes, an oily film, or cracks.

- Measure the air gap between the center and side electrode ([Figure 36](#)). The air gap should measure 0.76 mm (0.030 inch).

**Note:** if the air gap is not correct, bend the side electrode to adjust the air gap.

7. Thread the spark plug into the engine, and torque the plug to 27 N·m (20 ft-lb).
8. Repeat steps 2 through 6 at the other cylinder.

## Cleaning the Engine Screen and the Oil Cooler

**Service Interval:** Before each use or daily

Before each use, check and clean the engine screen and oil cooler. Remove any build up of grass, dirt or other debris from the oil cooler and engine screen (Figure 37).

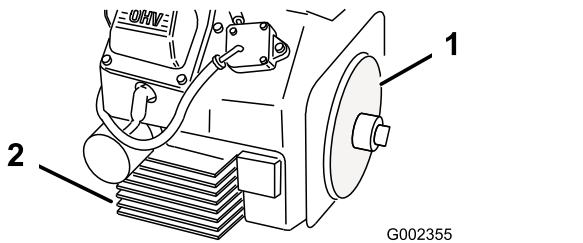

**Figure 37**

1. Engine screen
2. Oil cooler

## Fuel System Maintenance

### Servicing the Carbon Canister

#### Replacing the Carbon Canister Air Filter

**Service Interval:** Every 200 hours

1. Prepare the machine for maintenance; refer to [Preparing for Machine \(page 25\)](#).
2. Remove and discard the carbon canister air filter (Figure 38).

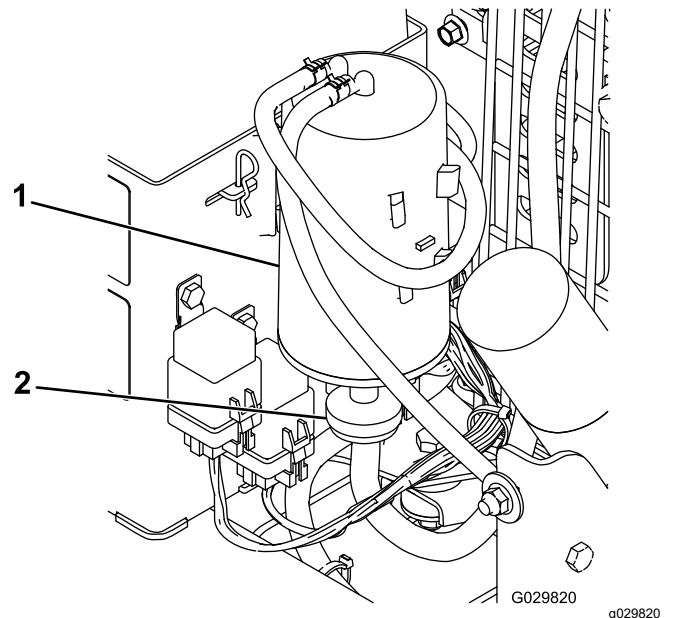

**Figure 38**

1. Carbon canister
2. Carbon canister air filter

3. Install the new air filter.

#### Replacing the Carbon Canister Purge-line Filter

**Service Interval:** Every 200 hours

**Note:** Check the purge-line filter occasionally for dirt. If the filter appears to be dirty, replace it.

1. Prepare the machine for maintenance; refer to [Preparing for Machine \(page 25\)](#).

2. Move the spring-type hose clamps on both sides of the carbon canister purge-line filter away from the filter (Figure 39).

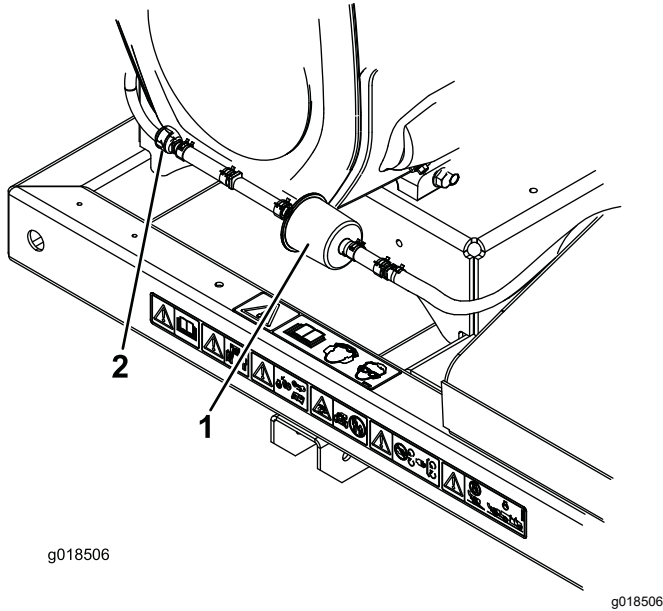

Figure 39

1. Carbon-canister purge-line filter
2. Check valve

3. Remove and discard the carbon filter (Figure 39).
4. Install a new filter into the hose with the arrow on the filter pointing toward the check valve and secure it with the hose clamps (Figure 39).

## Replacing the Fuel Filter

**Service Interval:** Every 500 hours

Never install a dirty filter if it is removed from the fuel line.

1. Prepare the machine for maintenance; refer to [Preparing for Machine \(page 25\)](#).
2. Allow the machine to cool down.
3. Squeeze the ends of the hose clamps together and slide them away from the filter (Figure 40).

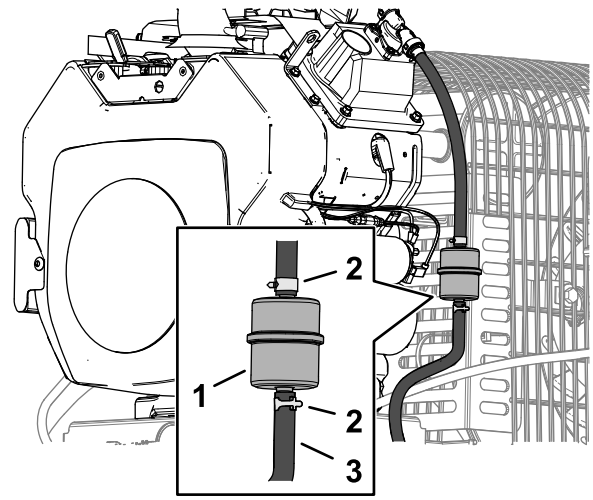

Figure 40

1. Fuel filter
2. Hose clamp
3. Fuel hose

4. Remove the filter from the fuel lines.
5. Install a new filter and move the hose clamps close to the filter (Figure 40).

## Servicing the Fuel Tank

### **⚠ DANGER**

**In certain conditions, fuel is extremely flammable and highly explosive. A fire or explosion from fuel can burn you and others and can damage property.**

- Drain fuel from the fuel tank when the engine is cold. Do this outdoors in an open area. Wipe up any fuel that spills.
- **Never smoke when draining fuel, and stay away from an open flame or where a spark may ignite the fuel fumes.**

1. Prepare the machine for maintenance; refer to [Preparing for Machine \(page 25\)](#).
2. Shut off the engine, remove the key, and wait for all moving parts to stop before leaving the operating position.
3. Loosen the hose clamp at the fuel filter and slide it up the fuel line away from the fuel filter (Figure 40).
4. Disconnect the fuel line from the fuel filter (Figure 40).

**Note:** Allow fuel to drain into a fuel container can or drain pan (Figure 40).

**Note:** This is the best time to install a new fuel filter because the fuel tank is empty.

5. Install the fuel line onto the fuel filter. Slide the hose clamp close to the fuel filter to secure the fuel line ([Figure 40](#)).

# Electrical System Maintenance

**Important:** Before welding on the machine, disconnect the controller and the negative cable from the battery to prevent damage to the electrical system.

## Electrical System Safety

- Disconnect the battery before repairing the machine. Disconnect the negative terminal first and the positive last. Connect the positive terminal first and the negative last.
- Charge the battery in an open, well-ventilated area, away from sparks and flames. Unplug the charger before connecting or disconnecting the battery. Wear protective clothing and use insulated tools.

## Fuses

### Replacing the Engine Fuse

1. Prepare the machine for maintenance; refer to [Preparing for Machine](#) (page 25).
2. Near the starter motor, separate the halves of the in-line fuse holder of the engine wire harness ([Figure 41](#)).

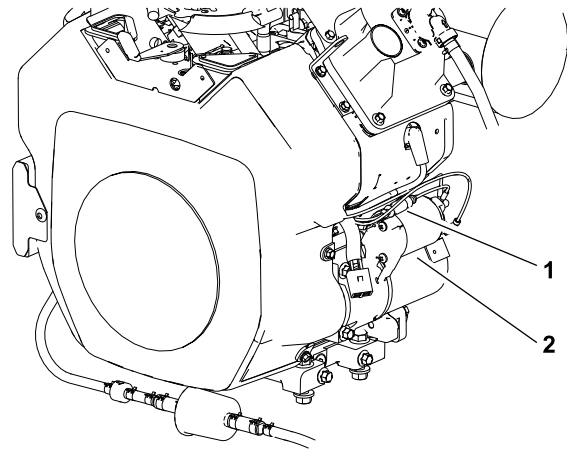

**Figure 41**

g233945

1. Fuse
2. Starter motor

3. Remove the open fuse from the fuse holder.
4. Insert a new fuse (30 A) into the fuse holder.
5. Assemble the halves of the in-line fuse holder ([Figure 41](#)).



## Replacing the Machine Fuses

1. At the front, inboard side of the control tower, remove the fuse-block cover from the fuse block (Figure 42).

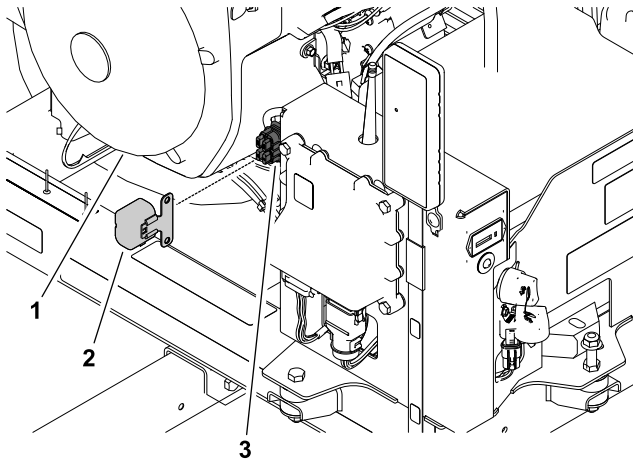

Figure 42

g233941

1. Engine
2. Fuse-block cover
3. Fuse block

2. Remove the open fuse from the fuse block (Figure 42).
3. Insert a new fuse into the fuse-block slot (Figure 43).

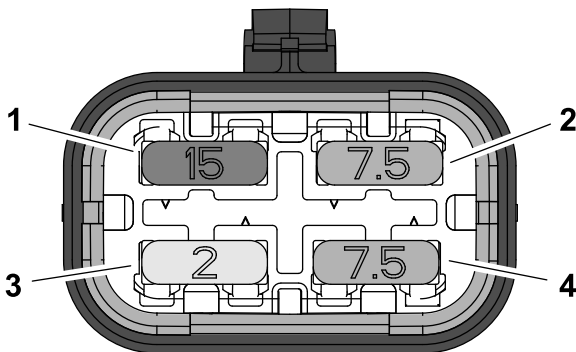

Figure 43

g341792

1. Fuse F-3 (15 A—electrical accessory)
2. Fuse F-1 (7.5 A)
3. Fuse F-4 (2 A—TEC controller)
4. Fuse F-2 (7.5 A)

4. Assemble fuse-block cover to the fuse block

A fuse block is part into the machine wire harness. It is located behind the receiver on the right side of the control tower (Figure 42).

## Drive System Maintenance

### Checking Tire Air Pressure

**Service Interval:** Before each use or daily

Check the tire pressure (Figure 44).

The correct tire pressure is 96.5 kPa (14 psi).

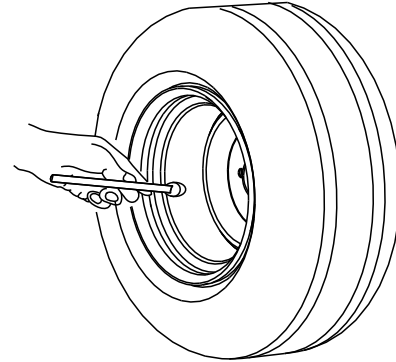

G001055

Figure 44

g001055

### Torquing the Wheel Lug Nuts

**Service Interval:** After the first 10 hours

#### ⚠ WARNING

Failure to maintain proper torque could result in failure or loss of wheel and could result in personal injury.

Torque wheel lug nuts to 95 to 122 N·m (70 to 90 ft-lb).

1. Prepare the machine for maintenance; refer to [Preparing for Machine \(page 25\)](#).
2. Torque the wheel lug nuts to 95 to 122 N·m (70 to 90 ft-lb).

### Inspecting the Tires

**Service Interval:** Every 100 hours

Operating accidents can damage a tire or rim, so inspect the tire condition after an accident.

The DOT tire information is located on the side of each tire. This information gives load and speed ratings. Replacement tires should have the same or better ratings.

Figure 45 is an example of tire wear caused by under inflation.

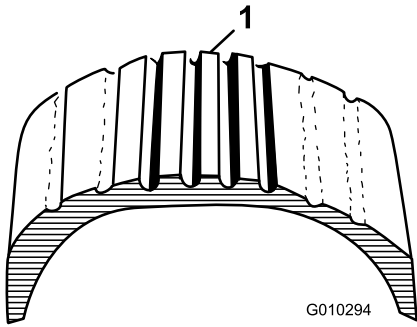

Figure 45

1. Example of tire wear caused by underinflation

Figure 46 is an example of tire wear caused by over inflation.

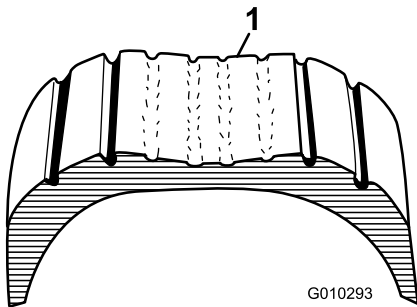

Figure 46

1. Example of tire wear caused by overinflation

## Belt Maintenance

### Adjusting the Nozzle-Control Belt Tension

**Service Interval:** After the first 8 hours

Every 50 hours

If the nozzle-control belt slips while changing blower-nozzle direction, adjust the belt tension.

1. Prepare the machine for maintenance; refer to [Preparing for Machine \(page 25\)](#).
2. Loosen the 2 flange capscrews and 2 flange locknuts securing the motor-mounting bracket to the housing mount of the machine frame ([Figure 47](#)).

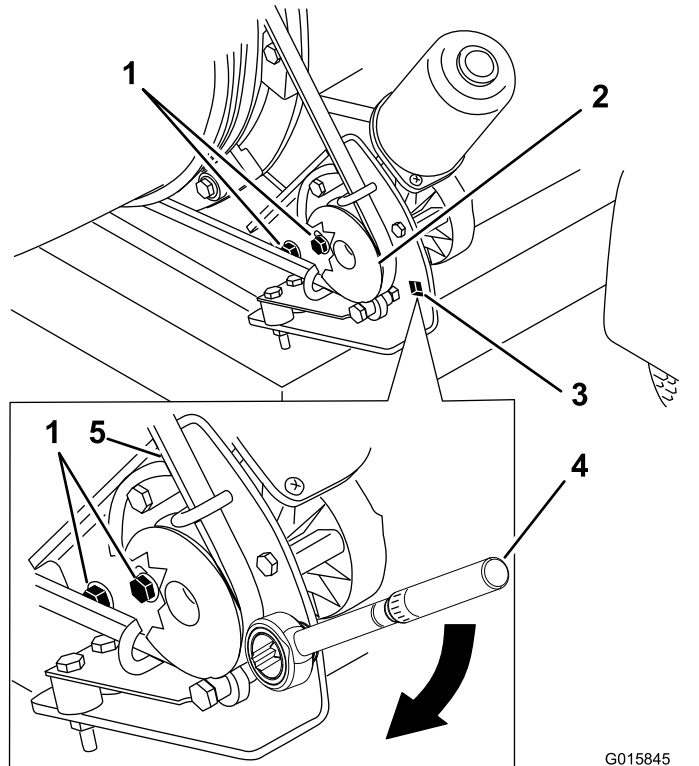

Figure 47

- |                           |   |
|---------------------------|---|
| 1. Mounting bolts         | 4. Torque wrench in pulley mounting bracket—22.6 to 26.0 N·m (200 to 230 in-lb) |
| 2. Pulley                 | 5. Belt   |
| 3. Hole for torque wrench |   |

3. Insert the drive of a torque wrench into the pulley mounting bracket as shown in [Figure 47](#).
4. Pivot the motor-mounting bracket away from the blower nozzle ([Figure 47](#)) until the torque wrench reads 22.6 to 26.0 N·m (200 to 230 in-lb).

5. While holding belt tension, tighten the 2 flange capscrews and 2 flange locknuts.

## Blower Maintenance

### Checking the Blower-Nozzle Clamp

**Service Interval:** Before each use or daily

1. Prepare the machine for maintenance; refer to [Preparing for Machine \(page 25\)](#).
2. Check the blower-nozzle clamp for signs of wear or damage ([Figure 48](#)).

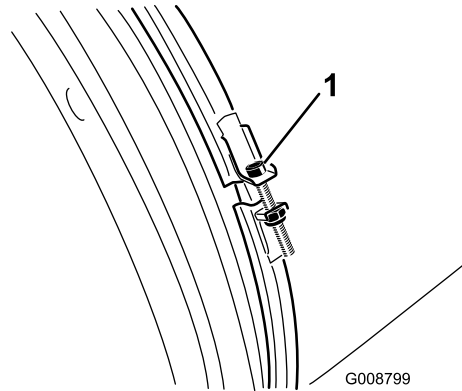

**Figure 48**

1. Blower-nozzle clamp

- 
3. Check the blower-nozzle clamp daily to ensure that it is tight ([Figure 48](#)).

**Important:** If the blower nozzle contacts an obstacle or through a low area in the terrain, the blower-nozzle clamp could become loose.

4. If the clamp is loose, torque the nut of the clamp to 5.1 to 5.7 N·m (45 to 50 in-lb).

### Cleaning the Nozzle Guides

**Service Interval:** Before each use or daily

1. Prepare the machine for maintenance; refer to [Preparing for Machine \(page 25\)](#).
2. Remove any grass, dirt or debris buildup around and in between the nozzle guides ([Figure 49](#)).

**Note:** If the nozzle guides are not free of debris, the nozzle may not rotate freely, which may damage the motor.

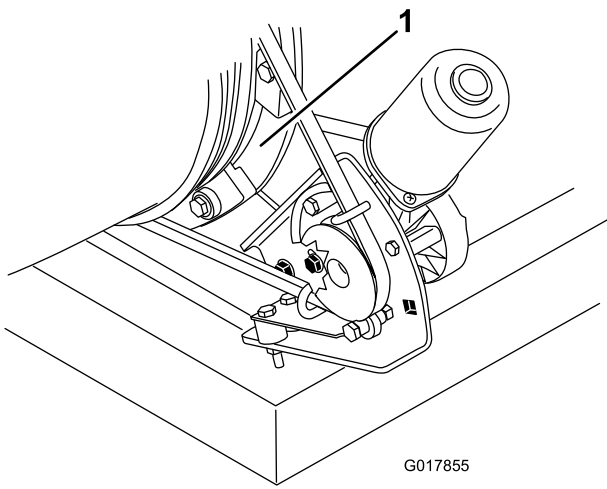

**Figure 49**

1. Nozzle guides

# Handheld Remote Maintenance

## Handheld Remote and the Wireless-Control Module

The handheld remote must link with the wireless-control module before you can use the remote control system. The handheld remote is associated to the wireless-control module at the factory. When you need to re-establish handheld remote and wireless-control module communication (e.g., introducing a new or spare remote control to an existing base unit or changing the signal frequency due to local interference issues), refer to [Associating the Remote and the Control Module \(page 36\)](#).

You can associate only Pro Force handheld remote to the Pro Force wireless-control module. Associating a Pro Force remote control to a different Pro Force wireless-control module disassociates that remote control from the original Pro Force machine.

**Note:** Local interference during operation may disassociate the handheld remote from the wireless-control module. Since the wireless-control module selects the best of numerous signal frequencies during the association process, move the machine to the area of signal disruption or disassociation, and perform the association procedure for best results.

## Associating the Remote and the Control Module

**Important:** Read the entire procedure before starting it.

1. Prepare the machine for maintenance; refer to [Preparing for Machine \(page 25\)](#).
2. Rotate the ignition key to the STOP position.
3. While holding the handheld remote, stand near the wireless-control module in an area with an unobstructed, clear line-of-sight to the antenna ([Figure 50](#)).

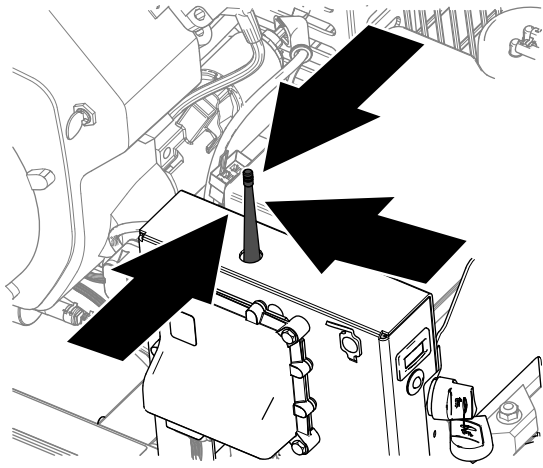

Figure 50

g343880

4. Simultaneously press and hold the ROTATE NOZZLE LEFT and ROTATE NOZZLE RIGHT buttons (Figure 51).

**Note:** The LED will blink about once per second.

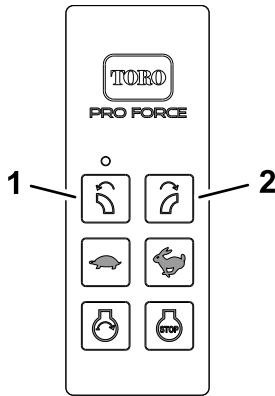

Figure 51

g343716

1. ROTATE NOZZLE LEFT button
2. ROTATE NOZZLE RIGHT button

5. Continue to hold both buttons until the LED begins blinking about twice per second.
6. Release both buttons.
7. Press and hold the ROTATE NOZZLE LEFT button (Figure 51).
8. Continue holding the ROTATE NOZZLE LEFT button (Figure 51) and turn the ignition key start to the RUN position.

**Note:** The LED turns solid if the procedure is successful. It may take up to 20 seconds for the LED turns solid.

9. Release the ROTATE NOZZLE LEFT button (Figure 51), and rotate the ignition key to the STOP position.

**Note:** The remote-control system is ready for use with the associated handheld remote.

## Replacing the Remote Batteries

**Battery specification:** AAA (1.5 V)

**Quantity:** 4

1. Remove the 6 screws securing the cover halves of the handheld remote together, and remove the back cover (Figure 52).

**Note:** If possible, leave the rubber seal and steel gasket in the channel when removing the cover and batteries.

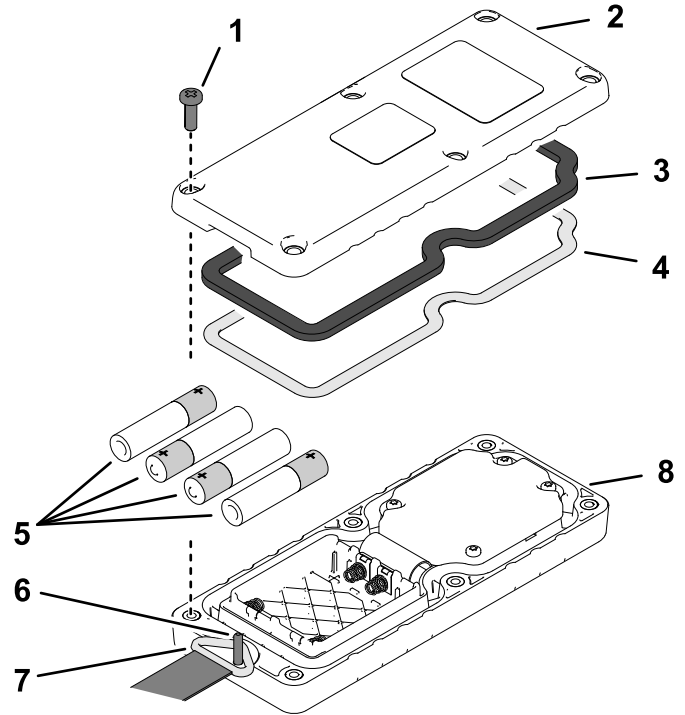

Figure 52

g341770

- |                 |                  |
|-----------------|------------------|
| 1. Screw        | 5. AAA batteries |
| 2. Back cover   | 6. Lanyard pin   |
| 3. Seal         | 7. Lanyard ring  |
| 4. Steel gasket | 8. Front cover   |

2. Remove the discharged batteries and properly dispose in accordance with local regulations.
3. Observing battery polarity as shown in Figure 53, insert the new batteries into the terminal cradles.

**Note:** When installing batteries, observe proper polarity markings (Figure 53) that are embossed

onto the battery compartment to avoid damaging the terminal cradles. You will not damage the machine if you incorrectly installing the batteries in the handheld remote, but the handheld remote will not operate.

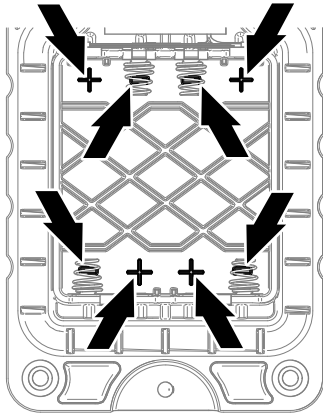

g341771

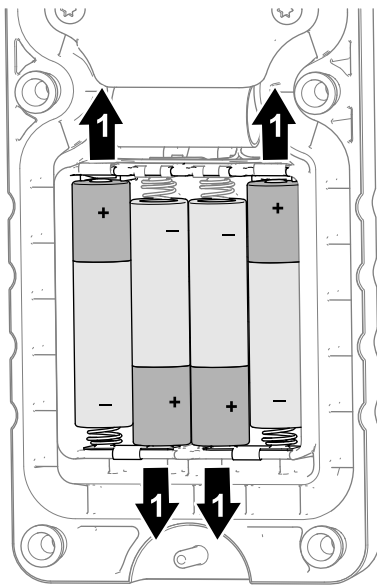

g341769

**Figure 53**

1. Positive battery polarity
- 
4. Ensure that the steel gasket and rubber seal are seated in the channel in the cover half and align the back cover to the front cover (Figure 52).
  5. Align the lanyard ring over the lanyard pin (Figure 52).
  6. Assemble the back cover to the and front cover with 6 screws (Figure 52).
  7. Torque the screws to 1.5 to 1.7 N·m (13 to 15 in-lb).

# Troubleshooting Fault Codes

## Resolving Fault Codes

If the diagnostic light indicates a system fault, perform the following procedures:

- [Entering Diagnostic Mode and Checking the Codes \(page 40\)](#)
- [Resetting the Fault Codes \(page 40\)](#)
- [Exiting Diagnostic Mode \(page 40\)](#)

### Fault-Code Table

Fault Code	Diagnostic Light Flash Pattern	Fault Description	Fault Causes
11	Flash once—pause—flash once—long pause—then the pattern repeats	The TEC controller or the wireless-control module cannot communicate.	The wire-harness connector at the TEC controller or the wireless-control module is loose, corroded, or damaged.
			The wire harness is damaged; contact your authorized Toro distributor.
			The wireless-control module is damaged; contact your authorized Toro Distributor.
12	Flash once—pause—flash 2 times—long pause—then the pattern repeats	The software version in the TEC, wireless-control module, or handheld remote is incompatibility with one of these other components.	Associate the handheld remote; refer to the machine Operator's Manual
			Install the correct software; contact your authorized Toro Distributor.
13	Flash once—pause—flash 3 times—long pause—then the pattern repeats	Wrong handheld remote associated with the wireless-control module.	The handheld remote is associated with a different Pro Force machine.
			The handheld remote is from the wrong type of machine, such as a MH-400 with a ProPass handheld.
14	Flash once—pause—flash 4 times—long pause—then the pattern repeats	The energize to run (ETR) circuit was interrupted because of low oil pressure (10 seconds or longer).	Check the engine-oil level, and adjust the oil level as necessary.
			The engine oil pressure switch is damaged or worn; contact your authorized Toro Distributor.
			The wire harness is damaged; contact your authorized Toro Distributor.
15	Flash once—pause—flash 5 times—long pause—then the pattern repeats	The energize to run (ETR) circuit was interrupted because of low machine battery voltage (less than 5.5 V).	Check the battery cable condition. Check that the cable hardware is tight.
			Test the battery, and if needed charge it; refer to the <i>Service Manual</i> . Replace the battery if needed.
			Test the engine alternator; refer to the <i>Service Manual</i> . Replace alternator if needed.
			Test the engine voltage regulator/rectifier; refer to the <i>Service Manual</i> . Replace regulator/rectifier if needed.

# Entering Diagnostic Mode and Checking the Codes

1. Turn the ignition key to the STOP position.
2. Remove the tethered cap from the single-pin connector and the single-socket connector (Figure 54A).
3. Plug the single-pin connector into the single-socket connector (Figure 54B).

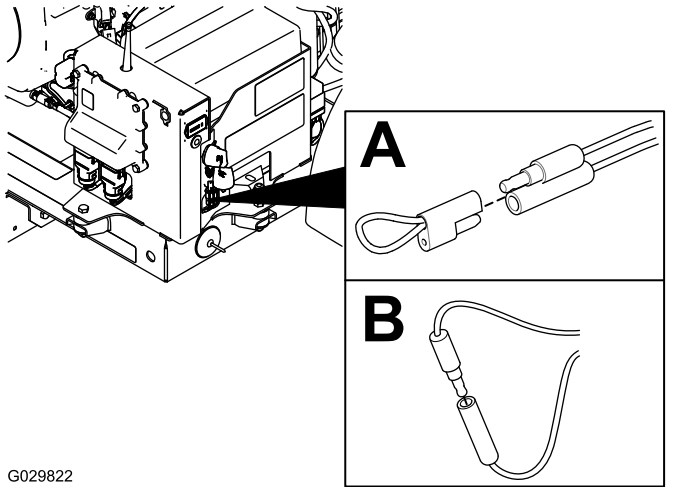

Figure 54

4. Turn the key to the RUN position.
5. Watch the flash-pattern-sequence of the diagnostic light for the following signals, then consult the fault-code table:
  - The number and order of flashes in each flash-pattern-sequence.
  - The order and length of time for each pause in each flash-pattern-sequence.

**Note:** If there are multiple machine faults active, each fault will flash followed by a long pause. After each active faults has been displayed, the fault sequence will repeat. If no active faults exist, the diagnostic light will flash continuously once per second.

## Resetting the Fault Codes

1. Turn the ignition key to the RUN position .
2. Remove the single-pin connector from the single-socket connector (Figure 55).

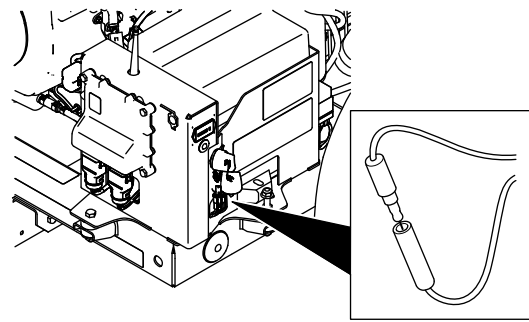

Figure 55

g342081

3. Plug the single-pin connector into the single-socket connector (Figure 55).

**Note:** The diagnostic light continuously flashes once per second.

## Exiting Diagnostic Mode

1. Turn the key to the OFF position (Figure 56).

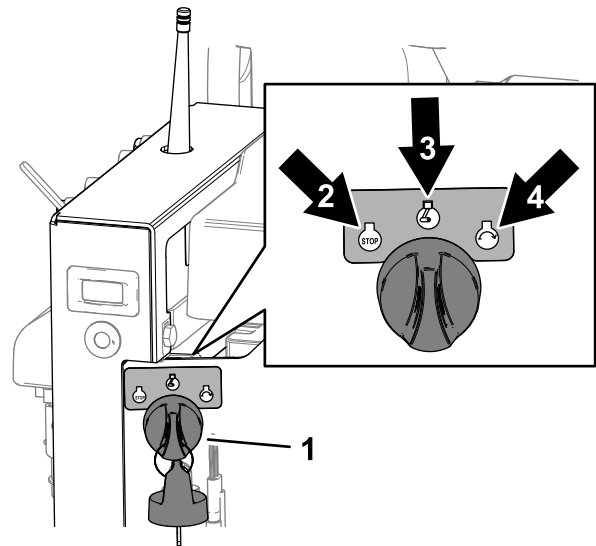

Figure 56

g341833

1. Ignition key
2. STOP position
3. RUN/ACCESSORY position
4. START position

2. Remove the single-pin connector from the single-socket connector (Figure 57).



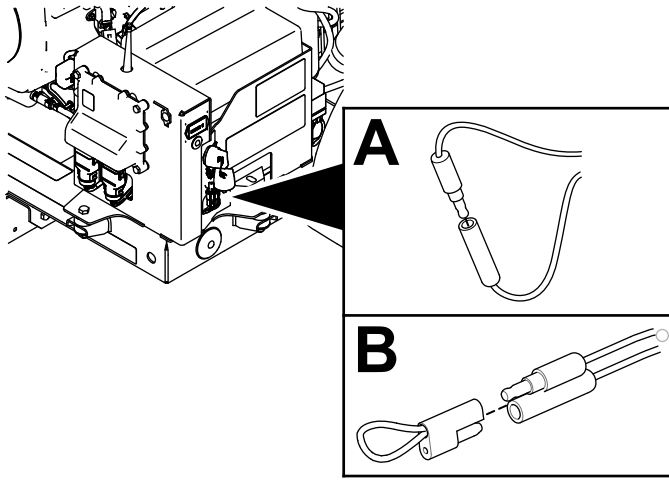

Figure 57

g342082

- 
3. Plug the single-pin connector and the single-socket connector into tethered cap (Figure 57).

## Cleaning

### Washing the Machine

**Important:** Do not use brackish or reclaimed water to clean the machine.

**Important:** Do not pressure wash the machine.

- Wash the machine with mild detergent and water.
- Avoid excessive use of water, especially near the control console.

### Disposing of Waste

Engine oil, engine and remote control batteries are pollutants to the environment. Dispose of these according to your state and local regulations.

# Storage

## Storage Safety

Shut off the machine, remove the key (if equipped), and wait for all movement to stop before you leave the operator's position. Allow the machine to cool before adjusting, servicing, cleaning, or storing it.

## Storing the Machine

1. Park the machine on a level surface, shut off the engine, remove the key from the ignition, wait for all parts to stop moving, and remove the spark plug wire.
2. Remove grass clippings, dirt, and grime from the external parts of the entire machine, especially the engine. Clean dirt and chaff from the outside of the engine cylinder head fins and blower housing.

**Important:** You can wash the machine with mild detergent and water. Do not pressure wash the machine. Avoid excessive use of water.

3. Service the air cleaner; refer to [Servicing the Air Cleaner \(page 25\)](#).
4. Change the crankcase oil; refer to [Changing the Oil \(page 28\)](#).
5. Check the tire pressure; refer to [Checking Tire Air Pressure \(page 33\)](#).
6. Prepare the machine for storage when non-use occurs over 30 days. Prepare machine for storage as follows:
  - A. Add a petroleum-based stabilizer/conditioner to fuel in the tank. Follow mixing instructions from stabilizer manufacture. Do not use an alcohol based stabilizer (ethanol or methanol).

**Note:** A fuel stabilizer/conditioner is most effective when mixed with fresh fuel, and used at all times.
  - B. Run the engine to distribute conditioned fuel through the fuel system (5 minutes).
  - C. Shut off the engine, allow it to cool, and drain the fuel tank; refer to [Servicing the Fuel Tank \(page 31\)](#).
  - D. Start the engine and run it until it stops.
  - E. Choke the engine. Start and run the engine until it does not start.
  - F. Dispose of fuel properly. Recycle according to local codes.

**Important:** Do not store fuel containing stabilizer/conditioner longer than the duration recommended by the fuel-stabilizer manufacturer.

7. Remove the spark plug(s) and check its condition; refer to [Checking the Spark Plugs \(page 29\)](#). With the spark plug(s) removed from the engine, pour 2 tablespoons of engine oil into the spark plug hole. Now use the starter to crank the engine and distribute the oil inside the cylinder. Install the spark plug(s). Do not install the wire on the spark plug(s).
8. Check and tighten all fasteners. Repair or replace any part that is damaged or missing.
9. Paint all scratched or bare metal surfaces. Paint is available from your authorized Toro distributor.
10. Store the machine in a clean, dry garage or storage area. Remove the key from the ignition switch and keep it out of reach of children or other unauthorized users. Cover the machine to protect it and keep it clean.

**Notes:**

**Notes:**

**Notes:**

## EEA/UK Privacy Notice

### **Toro's Use of Your Personal Information**

The Toro Company ("Toro") respects your privacy. When you purchase our products, we may collect certain personal information about you, either directly from you or through your local Toro company or dealer. Toro uses this information to fulfil contractual obligations - such as to register your warranty, process your warranty claim or to contact you in the event of a product recall - and for legitimate business purposes - such as to gauge customer satisfaction, improve our products or provide you with product information which may be of interest. Toro may share your information with our subsidiaries, affiliates, dealers or other business partners in connection these activities. We may also disclose personal information when required by law or in connection with the sale, purchase or merger of a business. We will never sell your personal information to any other company for marketing purposes.

### **Retention of your Personal Information**

Toro will keep your personal information as long as it is relevant for the above purposes and in accordance with legal requirements. For more information about applicable retention periods please contact [legal@toro.com](mailto:legal@toro.com).

### **Toro's Commitment to Security**

Your personal information may be processed in the US or another country which may have less strict data protection laws than your country of residence. Whenever we transfer your information outside of your country of residence, we will take legally required steps to ensure that appropriate safeguards are in place to protect your information and to make sure it is treated securely.

### **Access and Correction**

You may have the right to correct or review your personal data, or object to or restrict the processing of your data. To do so, please contact us by email at [legal@toro.com](mailto:legal@toro.com). If you have concerns about the way in which Toro has handled your information, we encourage you to raise this directly with us. Please note that European residents have the right to complain to your Data Protection Authority.

# California Proposition 65 Warning Information

## What is this warning?

You may see a product for sale that has a warning label like the following:



**WARNING: Cancer and Reproductive Harm—[www.p65Warnings.ca.gov](http://www.p65Warnings.ca.gov).**

## What is Prop 65?

Prop 65 applies to any company operating in California, selling products in California, or manufacturing products that may be sold in or brought into California. It mandates that the Governor of California maintain and publish a list of chemicals known to cause cancer, birth defects, and/or other reproductive harm. The list, which is updated annually, includes hundreds of chemicals found in many everyday items. The purpose of Prop 65 is to inform the public about exposure to these chemicals.

Prop 65 does not ban the sale of products containing these chemicals but instead requires warnings on any product, product packaging, or literature with the product. Moreover, a Prop 65 warning does not mean that a product is in violation of any product safety standards or requirements. In fact, the California government has clarified that a Prop 65 warning "is not the same as a regulatory decision that a product is 'safe' or 'unsafe.'" Many of these chemicals have been used in everyday products for years without documented harm. For more information, go to <https://oag.ca.gov/prop65/faqs-view-all>.

A Prop 65 warning means that a company has either (1) evaluated the exposure and has concluded that it exceeds the "no significant risk level"; or (2) has chosen to provide a warning based on its understanding about the presence of a listed chemical without attempting to evaluate the exposure.

## Does this law apply everywhere?

Prop 65 warnings are required under California law only. These warnings are seen throughout California in a wide range of settings, including but not limited to restaurants, grocery stores, hotels, schools, and hospitals, and on a wide variety of products. Additionally, some online and mail order retailers provide Prop 65 warnings on their websites or in catalogs.

## How do the California warnings compare to federal limits?

Prop 65 standards are often more stringent than federal and international standards. There are various substances that require a Prop 65 warning at levels that are far lower than federal action limits. For example, the Prop 65 standard for warnings for lead is 0.5 µg/day, which is well below the federal and international standards.

## Why don't all similar products carry the warning?

- Products sold in California require Prop 65 labelling while similar products sold elsewhere do not.
- A company involved in a Prop 65 lawsuit reaching a settlement may be required to use Prop 65 warnings for its products, but other companies making similar products may have no such requirement.
- The enforcement of Prop 65 is inconsistent.
- Companies may elect not to provide warnings because they conclude that they are not required to do so under Prop 65; a lack of warnings for a product does not mean that the product is free of listed chemicals at similar levels.

## Why does Toro include this warning?

Toro has chosen to provide consumers with as much information as possible so that they can make informed decisions about the products they buy and use. Toro provides warnings in certain cases based on its knowledge of the presence of one or more listed chemicals without evaluating the level of exposure, as not all the listed chemicals provide exposure limit requirements. While the exposure from Toro products may be negligible or well within the "no significant risk" range, out of an abundance of caution, Toro has elected to provide the Prop 65 warnings. Moreover, if Toro does not provide these warnings, it could be sued by the State of California or by private parties seeking to enforce Prop 65 and subject to substantial penalties.



# The Toro Warranty

Two-Year or 1,500 Hours Limited Warranty

## Conditions and Products Covered

The Toro Company warrants your Toro Commercial product ("Product") to be free from defects in materials or workmanship for 2 years or 1,500 operational hours\*, whichever occurs first. This warranty is applicable to all products with the exception of Aerators (refer to separate warranty statements for these products). Where a warrantable condition exists, we will repair the Product at no cost to you including diagnostics, labor, parts, and transportation. This warranty begins on the date the Product is delivered to the original retail purchaser.

\* Product equipped with an hour meter.

## Instructions for Obtaining Warranty Service

You are responsible for notifying the Commercial Products Distributor or Authorized Commercial Products Dealer from whom you purchased the Product as soon as you believe a warrantable condition exists. If you need help locating a Commercial Products Distributor or Authorized Dealer, or if you have questions regarding your warranty rights or responsibilities, you may contact us at:

Toro Commercial Products Service Department  
8111 Lyndale Avenue South  
Bloomington, MN 55420-1196

952-888-8801 or 800-952-2740  
E-mail: [commercial.warranty@toro.com](mailto:commercial.warranty@toro.com)

## Owner Responsibilities

As the product owner, you are responsible for required maintenance and adjustments stated in your *Operator's Manual*. Repairs for product issues caused by failure to perform required maintenance and adjustments are not covered under this warranty.

## Items and Conditions Not Covered

Not all product failures or malfunctions that occur during the warranty period are defects in materials or workmanship. This warranty does not cover the following:

- Product failures which result from the use of non-Toro replacement parts, or from installation and use of add-on, or modified non-Toro branded accessories and products.
- Product failures which result from failure to perform recommended maintenance and/or adjustments.
- Product failures which result from operating the Product in an abusive, negligent, or reckless manner.
- Parts consumed through use that are not defective. Examples of parts which are consumed, or used up, during normal Product operation include, but are not limited to, brake pads and linings, clutch linings, blades, reels, rollers and bearings (sealed or greasable), bed knives, spark plugs, castor wheels and bearings, tires, filters, belts, and certain sprayer components such as diaphragms, nozzles, flow meters, and check valves.
- Failures caused by outside influence, including, but not limited to, weather, storage practices, contamination, use of unapproved fuels, coolants, lubricants, additives, fertilizers, water, or chemicals.
- Failure or performance issues due to the use of fuels (e.g. gasoline, diesel, or biodiesel) that do not conform to their respective industry standards.
- Normal noise, vibration, wear and tear, and deterioration. Normal "wear and tear" includes, but is not limited to, damage to seats due to wear or abrasion, worn painted surfaces, scratched decals or windows.

## Countries Other than the United States or Canada

Customers who have purchased Toro products exported from the United States or Canada should contact their Toro Distributor (Dealer) to obtain guarantee policies for your country, province, or state. If for any reason you are dissatisfied with your Distributor's service or have difficulty obtaining guarantee information, contact your Authorized Toro Service Center.

## Parts

Parts scheduled for replacement as required maintenance are warranted for the period of time up to the scheduled replacement time for that part. Parts replaced under this warranty are covered for the duration of the original product warranty and become the property of Toro. Toro will make the final decision whether to repair any existing part or assembly or replace it. Toro may use remanufactured parts for warranty repairs.

## Deep Cycle and Lithium-Ion Battery Warranty

Deep cycle and Lithium-Ion batteries have a specified total number of kilowatt-hours they can deliver during their lifetime. Operating, recharging, and maintenance techniques can extend or reduce total battery life. As the batteries in this product are consumed, the amount of useful work between charging intervals will slowly decrease until the battery is completely worn out. Replacement of worn out batteries, due to normal consumption, is the responsibility of the product owner. Note: (Lithium-Ion battery only): Refer to the battery warranty for additional information.

## Lifetime Crankshaft Warranty (ProStripe 02657 Model Only)

The ProStripe which is fitted with a genuine Toro Friction Disc and Crank-Safe Blade Brake Clutch (integrated Blade Brake Clutch (BBC) + Friction Disc assembly) as original equipment and used by the original purchaser in accordance with recommended operating and maintenance procedures, are covered by a Lifetime Warranty against engine crankshaft bending. Machines fitted with friction washers, Blade Brake Clutch (BBC) units and other such devices are not covered by the Lifetime Crankshaft Warranty.

## Maintenance is at Owner's Expense

Engine tune-up, lubrication, cleaning and polishing, replacement of filters, coolant, and completing recommended maintenance are some of the normal services Toro products require that are at the owner's expense.

## General Conditions

Repair by an Authorized Toro Distributor or Dealer is your sole remedy under this warranty.

**The Toro Company is not liable for indirect, incidental or consequential damages in connection with the use of the Toro Products covered by this warranty, including any cost or expense of providing substitute equipment or service during reasonable periods of malfunction or non-use pending completion of repairs under this warranty. Except for the Emissions warranty referenced below, if applicable, there is no other express warranty. All implied warranties of merchantability and fitness for use are limited to the duration of this express warranty.**

Some states do not allow exclusions of incidental or consequential damages, or limitations on how long an implied warranty lasts, so the above exclusions and limitations may not apply to you. This warranty gives you specific legal rights, and you may also have other rights which vary from state to state.

## Note Regarding Emissions Warranty

The Emissions Control System on your Product may be covered by a separate warranty meeting requirements established by the U.S. Environmental Protection Agency (EPA) and/or the California Air Resources Board (CARB). The hour limitations set forth above do not apply to the Emissions Control System Warranty. Refer to the Engine Emission Control Warranty Statement supplied with your product or contained in the engine manufacturer's documentation.