



Form No. 3438-380 Rev B

Count on it.

Operator's Manual

e-Dingo 500 Compact Tool Carrier

Model No. 22218—Serial No. 400000000 and Up

Model No. 22218G—Serial No. 400000000 and Up



This product complies with all relevant European directives; for details, please see the separate product specific Declaration of Conformity (DOC) sheet.

⚠ WARNING

CALIFORNIA Proposition 65 Warning

The power cord on this product contains lead, a chemical known to the State of California to cause birth defects or other reproductive harm. Wash hands after handling.

Battery posts, terminals, and related accessories contain lead and lead compounds, chemicals known to the State of California to cause cancer and reproductive harm. Wash hands after handling.

Use of this product may cause exposure to chemicals known to the State of California to cause cancer, birth defects, or other reproductive harm.

Important: With your mobile device, you can scan the QR code on the serial number decal (if equipped) to access warranty, parts, and other product information.

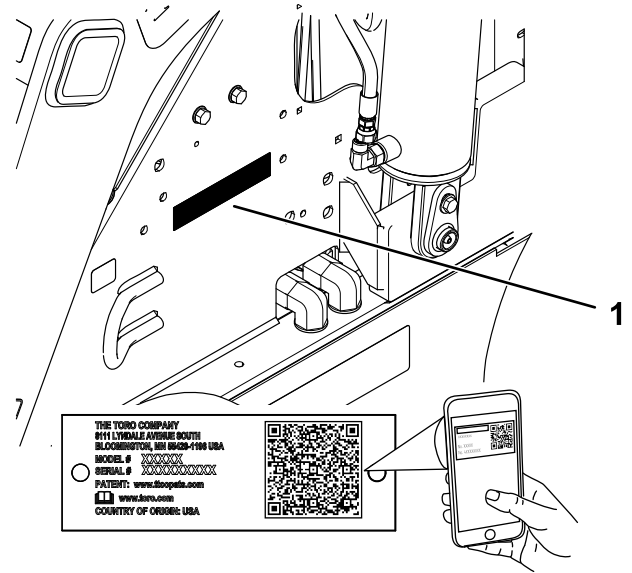

Figure 1

g311261

1. Model and serial number location

Model No. _____

Serial No. _____

Introduction

This machine is a compact tool carrier intended for use in various earth and materials moving activities for landscaping and construction work. It is designed to operate a wide variety of attachments, each of which performs a specialized function. Using this product for purposes other than its intended use could prove dangerous to you and bystanders.

Read this information carefully to learn how to operate and maintain your product properly and to avoid injury and product damage. You are responsible for operating the product properly and safely.

Visit www.Toro.com for product safety and operation training materials, accessory information, help finding a dealer, or to register your product.

Whenever you need service, genuine Toro parts, or additional information, contact an Authorized Service Dealer or Toro Customer Service and have the model and serial numbers of your product ready. [Figure 1](#) identifies the location of the model and serial numbers on the product. Write the numbers in the space provided.

This manual identifies potential hazards and has safety messages identified by the safety-alert symbol ([Figure 2](#)), which signals a hazard that may cause serious injury or death if you do not follow the recommended precautions.



Figure 2

Safety-alert symbol

g000502

This manual uses 2 words to highlight information. **Important** calls attention to special mechanical information and **Note** emphasizes general information worthy of special attention.

Contents

Safety	4	Checking the Hydraulic-Fluid Level.....	34
General Safety	4	Replacing the Hydraulic Filter	35
Safety and Instructional Decals	4	Changing the Hydraulic Fluid	35
Setup	8	Cleaning	36
1 Checking the Hydraulic Fluid Level	8	Removing Debris	36
2 Charging the Batteries	8	Washing the Machine	36
Product Overview	9	Storage	36
Controls	9	Storage Safety.....	36
InfoCenter Display	10	Storing the Machine.....	36
Specifications	13	Battery Storage Requirements	36
Attachments/Accessories	13	Troubleshooting	38
Before Operation	13		
Before Operation Safety	13		
Performing Daily Maintenance.....	14		
Adjusting the Thigh Support.....	14		
During Operation	14		
During Operation Safety	14		
Starting the Machine.....	16		
Driving the Machine	16		
Shutting Off the Machine	16		
Using Attachments	16		
Using the InfoCenter.....	18		
After Operation	19		
After Operation Safety	19		
Moving a Non-Functioning Machine.....	20		
Hauling the Machine	21		
Lifting the Machine	23		
Maintaining the Batteries	23		
Transporting the Batteries.....	24		
Using the Battery Charger	24		
Maintenance	27		
Maintenance Safety.....	27		
Recommended Maintenance Schedule(s)	27		
Pre-Maintenance Procedures	28		
Using the Cylinder Locks	28		
Accessing Internal Components	28		
Disconnecting the Main Power.....	29		
Lubrication	30		
Greasing the Machine.....	30		
Electrical System Maintenance	31		
Electrical System Safety	31		
Disconnecting or Connecting Power to the Machine	31		
Replacing the Static Strap	31		
Servicing the Batteries.....	31		
Maintaining the Battery Charger	31		
Servicing the Fuse	32		
Drive System Maintenance	32		
Checking the Tire Treads.....	32		
Checking the Wheel-Lug Nuts	32		
Brake Maintenance	33		
Testing the Parking Brake	33		
Hydraulic System Maintenance	33		
Hydraulic System Safety.....	33		
Relieving Hydraulic Pressure.....	33		
Hydraulic Fluid Specifications	34		

Safety

⚠ DANGER

There may be buried utility lines in the work area. Digging into them may cause a shock or an explosion.

Have the property or work area marked for buried lines and do not dig in marked areas. Contact your local marking service or utility company to have the property marked (for example, in the US, call 811 or in Australia, call 1100 for the nationwide marking service).

General Safety

Always follow all safety instructions to avoid serious injury or death.

- Do not carry a load with the arms raised; always carry loads close to the ground.
- Slopes are a major factor related to loss-of-control and tip-over accidents, which can result in severe injury or death. Operating the machine on any slope or uneven terrain requires extra caution.
- Operate the machine up and down slopes with the heavy end of the machine uphill and the load close to the ground. Weight distribution changes with attachments. An empty bucket makes the rear of the machine the heavy end, and a full bucket makes the front of the machine the heavy

end. Most other attachments make the front of the machine the heavy end.

- Have the property or work area marked for buried lines and other objects, and do not dig in marked areas.
- Read and understand the content of this *Operator's Manual* before starting the machine.
- Use your full attention while operating the machine. Do not engage in any activity that causes distractions; otherwise, injury or property damage may occur.
- Never allow children or untrained people to operate the machine.
- Keep your hands and feet away from the moving components and attachments.
- Do not operate the machine without the guards and other safety protective devices in place and working on the machine.
- Keep bystanders and children out of the operating area.
- Stop the machine, shut off the machine, and remove the key before servicing or unclogging the machine.

Improperly using or maintaining this machine can result in injury. To reduce the potential for injury, comply with these safety instructions and always pay attention to the safety-alert symbol ⚠, which means Caution, Warning, or Danger—personal safety instruction. Failure to comply with these instructions may result in personal injury or death.

Safety and Instructional Decals



Safety decals and instructions are easily visible to the operator and are located near any area of potential danger. Replace any decal that is damaged or missing.



93-6686

decal93-6686

1. Hydraulic fluid

2. Read the *Operator's Manual*.

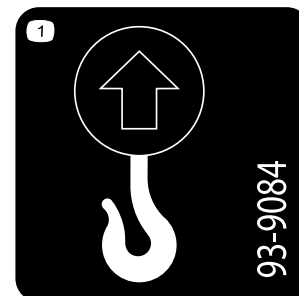

93-9084

decal93-9084

1. Lift point/Tie-down point



98-4387

decal98-4387

1. Warning—wear hearing protection.

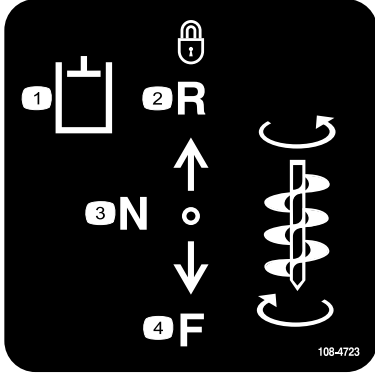

108-4723

decal108-4723

1. Auxiliary hydraulics
2. Locked reverse (detent)
3. Neutral (off)
4. Forward

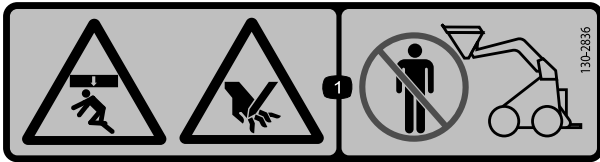

130-2836

decal130-2836

1. Crushing hazard from above; cutting hazard of the hand—keep away from the attachment and the lift arm.



130-2837

decal130-2837

1. Warning—do not carry passengers in the bucket.

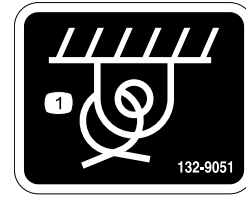

132-9051

decal132-9051

1. Tie-down point

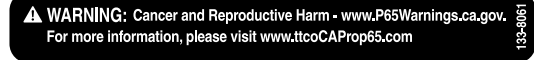

133-8061

decal133-8061

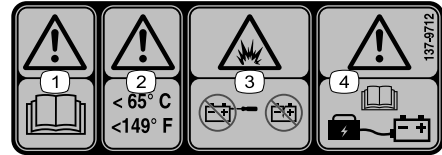

137-9712

decal137-9712

1. Warning—read the *Operator's Manual*.
2. Warning—keep at temperatures below 65° C (149° F).
3. Explosion hazard—do not open the battery; do not use a damaged battery.
4. Warning—read the *Operator's Manual* for battery charging information.



139-7707

decal139-7707

1. Parking brake—disengaged
2. Parking brake—engaged

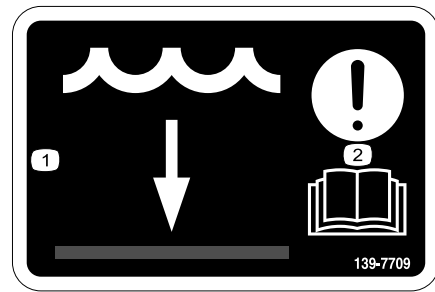

139-7709

decal139-7709

1. Water level
2. Attention—read the *Operator's Manual*.

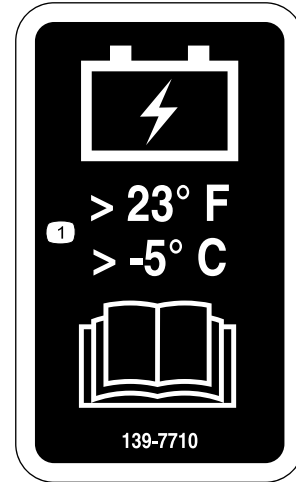

139-7710

decal139-7710

1. Keep the battery at temperatures above -5° C (23° F); read the *Operator's Manual*.

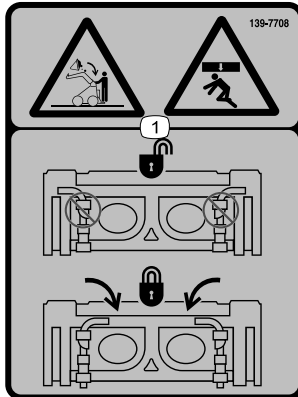

139-7708

decal139-7708

1. Crushing hazard from above, falling load—ensure that the quick-attach levers are locked.

22218 QUICK REFERENCE AID

CHECK/SERVICE (daily)
 1. OIL LEVEL, HYDRAULIC TANK
 2. BRAKE FUNCTION
 3. GREASE POINTS (12)

FLUID SPECIFICATIONS / CHANGE INTERVALS

SEE OPERATOR'S MANUAL FOR INITIAL CHANGE	FLUID TYPE	CAPACITY	CHANGE INTERVALS	FILTER	PART NO.
HYDRAULIC OIL	TORO PX EXTENDED LIFE HYDRAULIC FLUID	15 GALS. (56.7 L)	YEARLY 400 HRS.		540110

COMMON SERVICE PARTS

WHEEL ASM	139-7714
QUICK ATTACH ASM	132-4418

SEE OPERATOR'S MANUAL

139-7717

decal139-7717

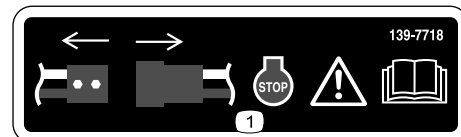

139-7718

decal139-7718

1. Warning—Disconnect the power, stop the machine, read the *Operator's Manual*.

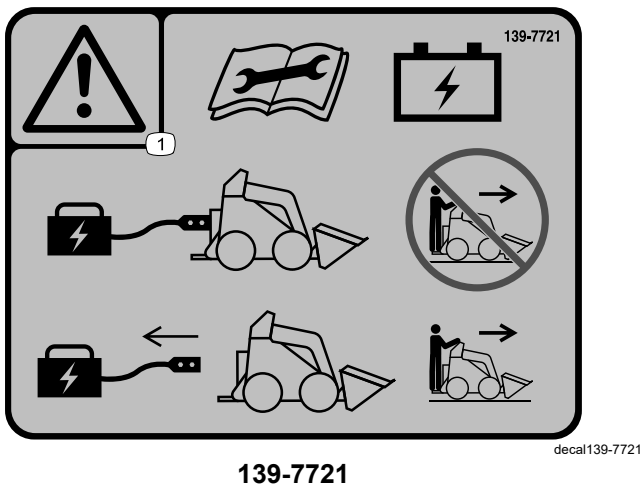

139-7721

1. Warning—read the *Operator's Manual* before performing battery maintenance; do not operate the machine when the battery charger is connected; disconnect the battery charger before operating the machine.

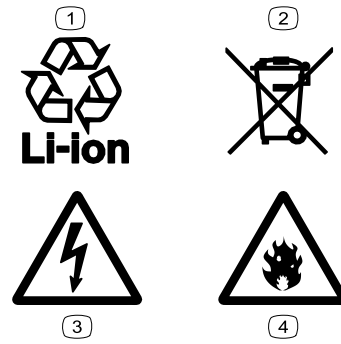

139-8343

1. Recyclable Lithium-Ion
2. Do not discard improperly.
3. Electric shock hazard
4. Fire hazard



137-9713

1. Warning—read the *Operator's Manual*.
2. Warning—keep out of the rain and other wet conditions.
3. Warning—do not touch the hot surface.
4. Warning—do not open the battery; do not use a damaged battery.
5. Explosion hazard—avoid sparks; no fire, open flames, or smoking.
6. Asphyxiation hazard, poisonous fumes or toxic gases—do not charge the battery in an enclosed space.
7. Electric shock hazard—do not perform maintenance on the battery.

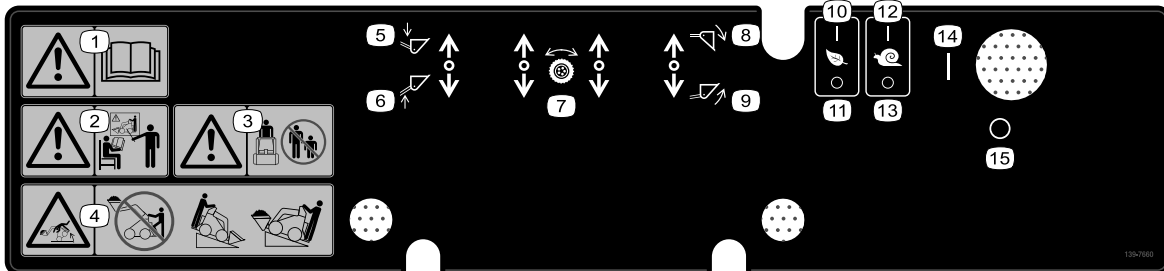

139-7660

1. Warning—read the *Operator's Manual*.
2. Warning—all operators should be trained before operating the machine.
3. Warning—keep bystanders away.
4. Tipping hazard—do not drive the machine with the load raised; position the heavy end of the machine uphill when driving on a slope.
5. Lower the attachment.
6. Raise the attachment.
7. Traction controls
8. Tilt the attachment down.
9. Tilt the attachment up.
10. Eco mode—On
11. Eco mode—Off
12. InchMode—On
13. InchMode—Off
14. On
15. Off

Setup

1

Checking the Hydraulic Fluid Level

No Parts Required

Procedure

Before starting the machine for the first time, check the hydraulic-fluid level; refer to [Checking the Hydraulic-Fluid Level \(page 34\)](#).

2

Charging the Batteries

No Parts Required

Procedure

Charge the batteries; refer to [Charging the Batteries \(page 25\)](#).

Product Overview

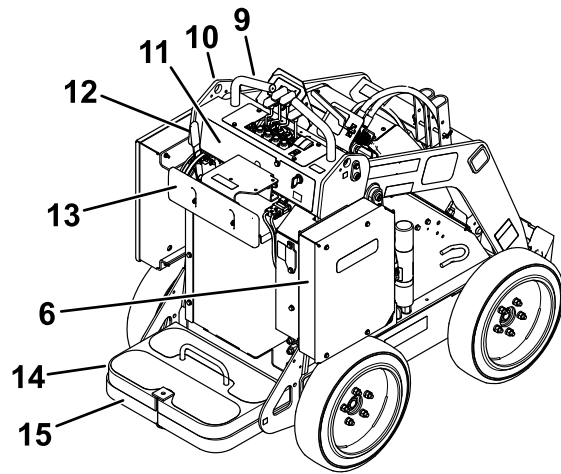
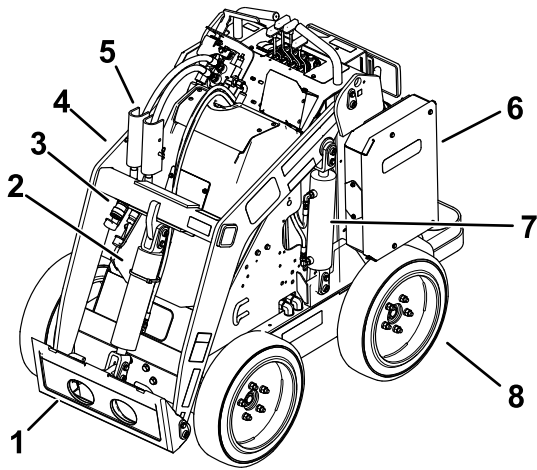

Figure 3

g281979

- | | | | |
|---------------------------------|------------------|-------------------------|-----------------------|
| 1. Attachment mount plate | 5. Cylinder lock | 9. Handle | 13. Thigh support |
| 2. Tilt cylinder | 6. Battery box | 10. Lift point | 14. Counterweight |
| 3. Auxiliary hydraulic couplers | 7. Lift cylinder | 11. Control panel | 15. Operator platform |
| 4. Loader arms | 8. Wheel | 12. Parking-brake lever | |

Controls

Control Panel

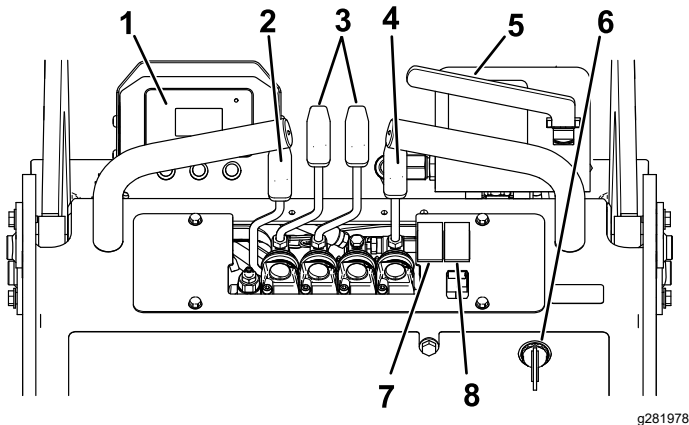

Figure 4

g281978

- | | |
|----------------------------|-------------------------------|
| 1. InfoCenter | 5. Auxiliary-hydraulics lever |
| 2. Loader-arm lever | 6. Key switch |
| 3. Traction-control levers | 7. Eco-mode switch |
| 4. Attachment-tilt lever | 8. Inch-mode switch |

Key Switch

The key switch has 2 positions: ON and OFF ([Figure 4](#)).

Use the key switch to start or shut off the machine; refer to [Shutting Off the Machine \(page 16\)](#) and [Shutting Off the Machine \(page 16\)](#).

Traction-Control Levers

- To move forward, move the traction-control levers forward.
 - To move rearward, move the traction-control levers rearward.
 - To turn, move the lever located on the side you want to turn back toward the NEUTRAL position while keeping the other lever engaged.
- Note:** The farther you move the traction-control levers in either direction, the faster the machine moves in that direction.
- To slow or stop, move the traction-control levers to the NEUTRAL position.

Attachment-Tilt Lever

- To tilt the attachment forward, slowly push the attachment-tilt lever forward.
- To tilt the attachment rearward, slowly pull the attachment-tilt lever rearward.

Loader-Arm Lever

- To lower the loader arms, slowly push the loader-arm lever forward.
- To raise the loader arms, slowly pull the loader-arm lever rearward.

Auxiliary-Hydraulics Lever

- To operate a hydraulic attachment in the forward direction, slowly pull the auxiliary-hydraulics lever out and then pull down.
- To operate a hydraulic attachment in the reverse direction, slowly pull the auxiliary-hydraulics lever out and then push it upward. This is also called the DETENT position because it does not require operator presence.

Parking-Brake Lever

- To engage the parking brake, rotate the lever down (Figure 5).
- To release the parking brake, rotate the lever up (Figure 5).

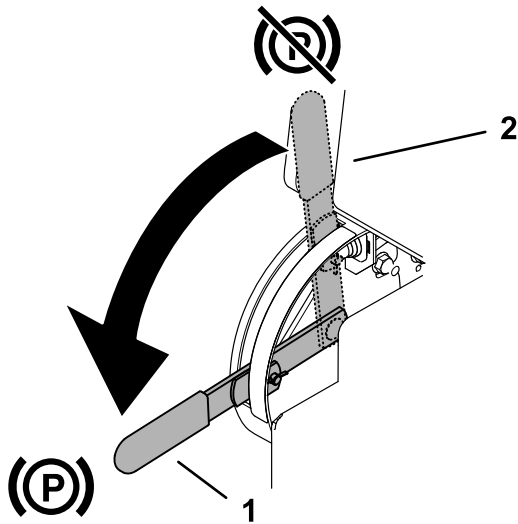

Figure 5

g303557

1. Parking-brake lever—engaged
2. Parking-brake lever—disengaged

Eco-Mode Switch

Press the switch to the ON position to activate Eco Mode. Use Eco Mode to reduce the motor speed and reduce battery consumption.

Inch-Mode Switch

Press the switch to the ON position to activate Inch Mode. Use Inch Mode to slow the speed of the machine when installing or removing attachments, making small adjustments with the machine, and turning corners.

Note: Inch Mode overrides any current settings (e.g., Eco mode, attachment modes). The machine will return to those settings when Inch Mode is off.

InfoCenter Display

The InfoCenter LCD display shows information about your machine, such as the operating status, various diagnostics and other information about the machine (Figure 6). There is a splash screen and main information screen of the InfoCenter. You can switch between the splash screen and main information screen at any time by pressing any of the InfoCenter buttons and then selecting the appropriate directional arrow.

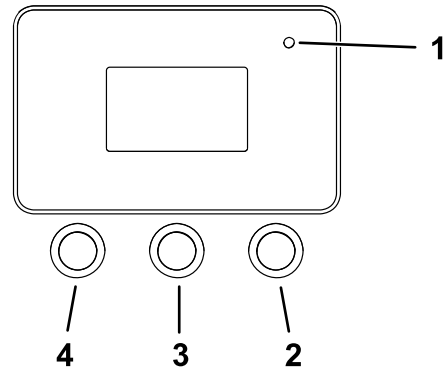

Figure 6

g264015

1. Indicator light
2. Right button
3. Middle button
4. Left button

- Left Button, Menu Access/Back Button—press this button to access the InfoCenter menus. You can use it to exit any menu that you are currently using.
- Middle Button—use this button to scroll down menus.
- Right Button—use this button to open a menu where a right arrow indicates additional content.

Note: The purpose of each button may change depending on what is required at the time. Each button is labeled with an icon displaying its current function.

Figure 7 shows what you may see on the InfoCenter when you run the machine. The splash screen displays for a few seconds after you turn the key to the ON position then the run screen displays.

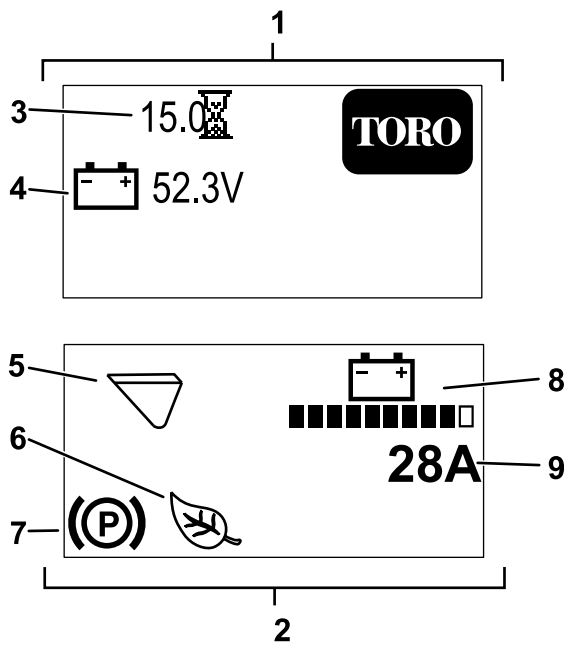

Figure 7

g315353

- | | |
|--|---|
| 1. Splash screen | 6. Eco or Inch Mode is on (Eco Mode shown). |
| 2. Run screen | 7. Parking brake is engaged. |
| 3. Hours operated | 8. Battery charge |
| 4. Battery voltage | 9. Instantaneous machine amperage |
| 5. Attachment mode (Bucket Mode shown) | |

	Parking brake is engaged.
	Hour meter
	Battery voltage
	Battery charge—each solid bar represents the charge in 10% increments.
	Eco Mode is on.
	Inch Mode is on.
	Cold start
	Bucket Mode is on.
	Hammer Mode is on.

InfoCenter Icon Descriptions

	Menu access
	Next
	Previous
	Scroll down
	Enter
	Change the attachment mode.
	Increase
	Decrease
	Exit menu
	Check PIN entry

InfoCenter Menus

To access the InfoCenter menu system, press the menu access button  while at the main screen. This will bring you to the main menu. Refer to the following tables for a synopsis of the options available from the menus:

Main Menu

Menu Item	Description
Faults	The FAULTS menu contains a list of the recent machine faults. Refer to the Service Manual or your Authorized Toro Dealer for more information on the FAULTS menu.
Service	The Service menu contains information on the machine such as hours of use and other similar numbers.
Diagnostics	The Diagnostics menu displays the state of each machine switch, sensor and control output. You can use this to troubleshoot certain issues as it will quickly tell you which machine controls are on and which are off.
Settings	The Settings menu allows you to customize and modify configuration variables on the InfoCenter display.
About	The About menu lists the model number, serial number, and software version of your machine.

Faults

Menu Item	Description
Current	Lists the total number of key-on hours (i.e., hours that the key has been in the ON position).
Last	Indicates the last key-on hour that the fault occurred on.
First	Indicates the first key-on hour that the fault occurred on.
Occurrences	Indicates the number of fault occurrences.

Service

Menu Item	Description
Hours	Lists the total number of hours that the key, motor, and Eco Mode have been on and the traction controls have been engaged.
Counts	Lists the number of times the motor has been started and the amperage hours for the battery.

Diagnostics

Menu Item	Description
Battery	Indicates the inputs and outputs for the battery. Inputs include the current battery voltage; outputs include the battery current and percentage state of charge.
Motor control	Indicates the inputs and outputs for the motor control. Inputs include key run, neutral, parking brake, auxiliary, Inch, Eco mode, and raise/lower; use these to check input feedback on the machine. Outputs include motor speed (in rpm), phase current, DC current, controller temperature, and motor temperature.

Settings

Menu Item	Description
Language	Controls the language used on the InfoCenter.
Backlight	Controls the brightness of the LCD display
Contrast	Controls the contrast of the LCD display.
Protected Menus	Allows you to access protected menus by inputting a passcode.

About

Menu Item	Description
Model	Lists the model number of the machine
Serial	Lists the serial number of the machine
S/W Rev	Lists the software revision of the master controller.
Motor Ctrl SW	Lists the software revision of the motor control.
Battery SW	Lists the software revision of the battery.

Specifications

Note: Specifications and design are subject to change without notice.

Width	89 cm (35 inches)
Length	152 cm (62 inches)
Height	125 cm (49 inches)
Weight (without attachment)	938 kg (2,068 lb)
Rated operating capacity—with 74.8 kg (165 lb) operator and the standard bucket	234 kg (515 lb)
Tipping capacity—with 74.8 kg (165 lb) operator and the standard bucket	590 kg (1,300 lb)
Wheelbase	71 cm (28 inches)
Dump height (with standard bucket)	120 cm (47 inches)
Reach—fully raised (with standard bucket)	71 cm (28 inches)
Height to hinge pin (narrow bucket in standard position)	168 cm (66 inches)

Attachments/Accessories

A selection of Toro approved attachments and accessories is available for use with the machine to enhance and expand its capabilities. Contact your Authorized Service Dealer or authorized Toro distributor or go to www.Toro.com for a list of all approved attachments and accessories.

To ensure optimum performance and continued safety certification of the machine, use only genuine Toro replacement parts and accessories. Replacement parts and accessories made by other manufacturers could be dangerous, and such use could void the product warranty.

Operation

Before Operation

Before Operation Safety

General Safety

- Never allow children or untrained people to operate or service the machine. Local regulations may restrict the age or require certified training of the operator. The owner is responsible for training all operators and mechanics.
- Become familiar with the safe operation of the equipment, operator controls, and safety decals.
- Always engage the parking brake, shut off the machine, remove the key, wait for all moving parts to stop, and allow the machine to cool before adjusting, servicing, cleaning, or storing the machine.
- Know how to stop the machine and shut off the machine quickly.
- Check that the safety switches and shields are attached and functioning properly. Do not operate the machine unless they are functioning properly.
- Locate the pinch-point areas marked on the machine and attachments; keep your hands and feet away from these areas.
- Before operating the machine with an attachment, ensure that the attachment is properly installed and that it is a genuine Toro attachment. Read all the attachment manuals.
- Evaluate the terrain to determine what accessories and attachments you need to properly and safely perform the job.
- Have the property or work area marked for buried lines and other objects, and do not dig in marked areas; note the location of unmarked objects and structures, such as underground storage tanks, wells, and septic systems.
- Inspect the area where you will use the equipment for uneven surfaces or hidden hazards.
- Ensure that the area is clear of bystanders before operating the machine. Stop the machine if a bystander enters the area.

Performing Daily Maintenance

Before starting the machine each day, perform the Each Use/Daily procedures listed in [Maintenance \(page 27\)](#).

Adjusting the Thigh Support

To adjust the thigh support ([Figure 8](#)), loosen the knobs and raise or lower the support pad to the desired height. You can also obtain additional adjustment by loosening the nut securing the pad to the adjustment plate and moving the plate up or down as needed. Tighten all fasteners securely when finished.

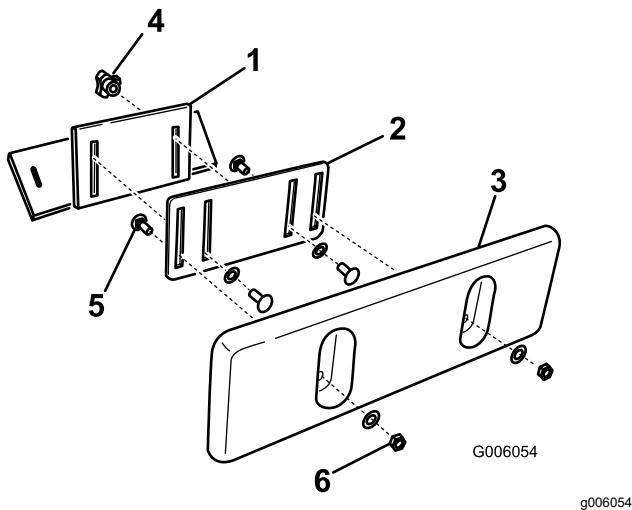

Figure 8

- | | |
|--------------------------|----------------------------|
| 1. Thigh-support bracket | 4. Knob and flat washer |
| 2. Adjustment plate | 5. Carriage bolt |
| 3. Thigh-support pad | 6. Locknut and flat washer |

During Operation

During Operation Safety

General Safety

- Do not carry a load with the arms raised. Always carry loads close to the ground.
- Do not exceed the rated operating capacity, as the machine may become unstable, which may result in loss of control.
- Use only Toro-approved attachments and accessories. Attachments can change the stability and the operating characteristics of the machine.
- For machines with a platform:
 - Lower the loader arms before stepping off the platform.
 - Do not try to stabilize the machine by putting your foot on the ground. If you lose control of the machine, step off the platform and away from the machine.
 - Do not place your feet under the platform.
 - Do not move the machine unless you are standing with both feet on the platform and your hands are holding onto the reference bars.
- Use your full attention while operating the machine. Do not engage in any activity that causes distractions; otherwise, injury or property damage may occur.
- Look behind and down before backing up to ensure that the path is clear.
- Never jerk the controls; use a steady motion.
- The owner/user can prevent and is responsible for accidents that may cause personal injury or property damage.
- Wear appropriate clothing including eye protection, long pants, substantial slip-resistant footwear, gloves, and hearing protection. Tie back long hair and do not wear loose clothing or loose jewelry.
- Do not operate the machine when you are tired, ill, or under the influence of alcohol or drugs.
- Never carry passengers and keep pets and bystanders away from the machine
- Operate the machine only in good light, keeping away from holes and hidden hazards.
- Ensure that all the drives are in neutral and engage the parking brake before starting the machine. Start the machine only from the operator's position.
- Use care when approaching blind corners, shrubs, trees, or other objects that may obscure vision.
- Slow down and use caution when making turns and crossing roads and sidewalks. Watch for traffic.

- Stop the attachment when you are not working.
- Stop the machine, shut off the machine, remove the key, and inspect the machine if you strike an object. Make any necessary repairs before resuming operation.
- Never leave a machine on when unattended.
- Before leaving the operating position, do the following:
 - Park the machine on a level surface.
 - Lower the loader arms and disengage the auxiliary hydraulics.
 - Engage the parking brake.
 - Shut off the machine and remove the key.
- Do not operate the machine when there is the risk of lightning.
- Operate the machine only in areas where there is sufficient clearance for you to safely maneuver. Be aware of obstacles in close proximity to you. Failure to maintain adequate distance from trees, walls, and other barriers may result in injury as the machine backs up during operation if you are not attentive to the surroundings.
- Check for overhead clearance (i.e., electrical wires, branches, ceilings, and doorways) before driving under any objects and do not contact them.
- Do not overfill the attachment and always keep the load level when raising the loader arms. Items in the attachment could fall and cause injury.
- Avoid starting or stopping on a slope. If the machine loses traction, proceed slowly, straight down the slope.
- Avoid turning on slopes. If you must turn, turn slowly and keep the heavy end of the machine uphill.
- Keep all movements on slopes slow and gradual. Do not make sudden changes in speed or direction.
- If you feel uneasy operating the machine on a slope, do not do it.
- Watch for holes, ruts, or bumps, as uneven surfaces could overturn the machine. Tall grass can hide obstacles.
- Use caution when operating on wet surfaces. Reduced traction could cause sliding.
- Evaluate the area to ensure that the ground is stable enough to support the machine.
- Use caution when operating the machine near the following:
 - Drop-offs
 - Ditches
 - Embankments
 - Bodies of water
 - Stairwells
 - Loading docks
 - Ramps

The machine could suddenly roll over if a wheel goes over the edge or the edge caves in. Maintain a safe distance between the machine and any hazard.

Slope Safety

- **Operate the machine up and down slopes with the heavy end of the machine uphill.** Weight distribution changes with attachments. An empty bucket makes the rear of the machine the heavy end, and a full bucket makes the front of the machine the heavy end. Most other attachments make the front of machine the heavy end.
- Raising the loader arms on a slope affects the stability of the machine. Keep the loader arms in the lowered position when on slopes.
- Slopes are a major factor related to loss of control and tip-over accidents, which can result in severe injury or death. Operating the machine on any slope or uneven terrain requires extra caution.
- Establish your own procedures and rules for operating on slopes. These procedures must include surveying the site to determine which slopes are safe for machine operation. Always use common sense and good judgment when performing this survey.
- Slow down and use extra care on slopes and uneven surfaces. Ground conditions can affect the stability of the machine.
- Do not remove or add attachments on a slope.
- Do not park the machine on a hillside or slope.

Starting the Machine

1. Stand on the platform.
2. Ensure that the parking brake is engaged and all 4 levers are in the NEUTRAL position.
3. Insert the key into the key switch and turn it to the ON position.

Note: The machine may have difficulty starting under severe cold conditions. When starting a cold machine, keep the machine above -18°C (0°F).

Note: When the machine temperature is below -1°C (30°F), the cold-start symbol (Figure 9) will appear on the InfoCenter while the motor increases speed for 2 minutes. During this time, do not move the traction controls while the parking brake is engaged; otherwise, the motor shuts off and the 2 minutes resets. The cold-start symbol disappears when the motor reaches full speed.



Figure 9

g304012

Driving the Machine

Use the traction controls to move the machine. The farther you move the traction controls in any direction, the faster the machine moves in that direction. Release the traction controls to stop the machine.

Shutting Off the Machine

1. Park the machine on a level surface, lower the loader arms, and engage the parking brake.
2. Ensure that the auxiliary hydraulics lever is in the NEUTRAL position.
3. Turn the key switch to the OFF position and remove the key.

⚠ CAUTION

Children or bystanders may be injured if they move or attempt to operate the machine while it is unattended.

Always remove the key and engage the parking brake when leaving the machine unattended.

Using Attachments

Installing an Attachment

Important: Use only Toro-approved attachments. Attachments can change the stability and the operating characteristics of the machine. The warranty of the machine may be voided if you use the machine with unapproved attachments.

Important: Before installing the attachment, ensure that the mount plates are free of any dirt or debris and that the pins rotate freely. If the pins do not rotate freely, grease them.

1. Position the attachment on a level surface with enough space behind it to accommodate the machine.
2. Start the machine.
3. Tilt the attachment mount plate forward.
4. Position the mount plate into the upper lip of the attachment receiver plate (Figure 10).

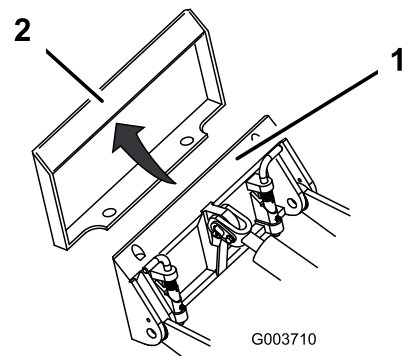

G003710

g003710

Figure 10

1. Mount plate
2. Receiver plate

5. Raise the loader arms while tilting back the mount plate at the same time.

Important: Raise the attachment enough to clear the ground and tilt the mount plate all the way back.

6. Shut off the machine and remove the key.
7. Engage the quick-attach pins, ensuring that they are fully seated in the mount plate (Figure 11).

Important: If the pins do not rotate to the engaged position, the mount plate is not fully aligned with the holes in the attachment receiver plate. Check the receiver plate and clean it if necessary.

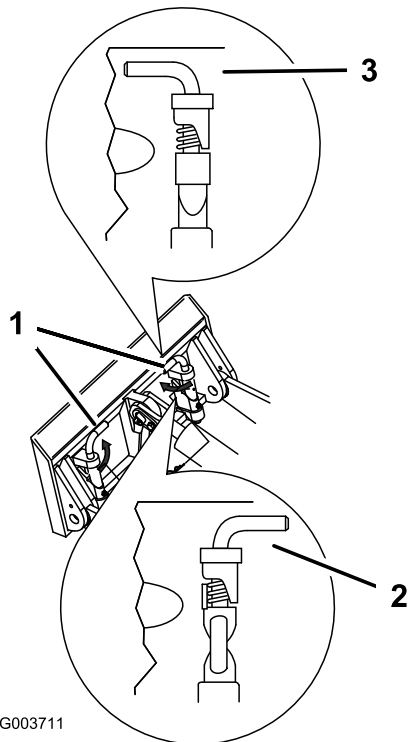

Figure 11

1. Quick-attach pins (engaged position)
2. Disengaged position
3. Engaged position

⚠ WARNING

If you do not fully seat the quick-attach pins through the attachment mount plate, the attachment could fall off the machine, crushing you or bystanders.

Ensure that the quick-attach pins are fully seated in the attachment mount plate.

Connecting the Hydraulic Hoses

⚠ WARNING

Hydraulic fluid escaping under pressure can penetrate skin and cause injury. Fluid injected into the skin must be surgically removed within a few hours by a doctor familiar with this form of injury; otherwise, gangrene may result.

- Ensure that all hydraulic-fluid hoses and lines are in good condition and all hydraulic connections and fittings are tight before applying pressure to the hydraulic system.
- Keep your body and hands away from pinhole leaks or nozzles that eject high-pressure hydraulic fluid.
- Use cardboard or paper to find hydraulic leaks; never use your hands.

⚠ CAUTION

Hydraulic couplers, hydraulic lines/valves, and hydraulic fluid may be hot. If you contact hot components, you may be burned.

- Wear gloves when operating the hydraulic couplers.
- Allow the machine to cool before touching hydraulic components.
- Do not touch hydraulic fluid spills.

If the attachment requires hydraulics for operation, connect the hydraulic hoses as follows:

1. Shut off the machine and remove the key.
 2. Move the auxiliary-hydraulics lever forward, backward, and back to the NEUTRAL position to relieve pressure at the hydraulic couplers.
 3. Remove the protective covers from the hydraulic connectors on the machine.
 4. Ensure that all foreign matter is cleaned from the hydraulic connectors.
 5. Push the attachment male connector into the female connector on the machine.
- Note:** When you connect the attachment male connector first, you relieve any pressure built up in the attachment.
6. Push the attachment female connector onto the male connector on the machine.
 7. Confirm that the connection is secure by pulling on the hoses.

Removing an Attachment

1. Park the machine on a level surface.
2. Lower the attachment to the ground.
3. Shut off the machine and remove the key.
4. Disengage the quick-attach pins by turning them to the outside.
5. If the attachment uses hydraulics, move the auxiliary-hydraulics lever forward, backward, and back to the NEUTRAL position to relieve pressure at the hydraulic couplers.
6. If the attachment uses hydraulics, slide the collars back on the hydraulic couplers and disconnect them.



Important: Connect the attachment hoses together to prevent hydraulic system contamination during storage.

7. Install the protective covers onto the hydraulic couplers on the machine.
8. Start the machine, tilt the mount plate forward, and back the machine away from the attachment.

Using the InfoCenter

Changing the Attachment Mode

1. From the Run screen, press the middle button to access the Attachment Change screen.
2. Press the middle or right button to switch between Hammer or Bucket mode.

Note: Turn on Eco mode when using Hammer mode. Hammer Mode , when used with Eco mode, slows the motor speed (in rpm) to reduce energy consumption when using attachments. Bucket Mode  maintains the motor speed.

3. Press the left button to return to the Run screen.

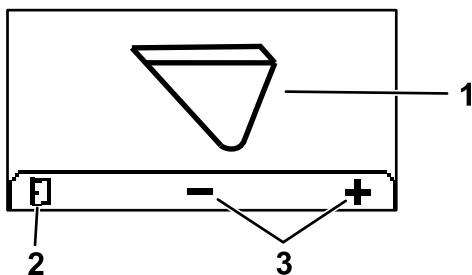

Figure 12

g304809

1. Current attachment mode
2. Change attachment mode
3. Return to Run screen

Accessing Protected Menus

Note: The factory default PIN code for you machine is either 0000 or 1234.

If you changed the PIN code and forgot the code, contact your Authorized Service Dealer for assistance.

1. From the MAIN MENU, use the center button to scroll down to the SETTINGS MENU and press the right button (Figure 13).

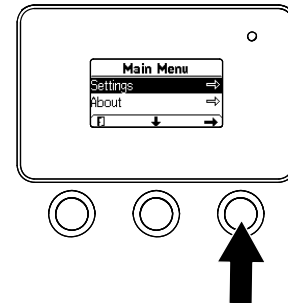

Figure 13

g264775

2. In the SETTINGS MENU, use the center button to scroll down to the PROTECTED MENU and press the right button (Figure 14A).

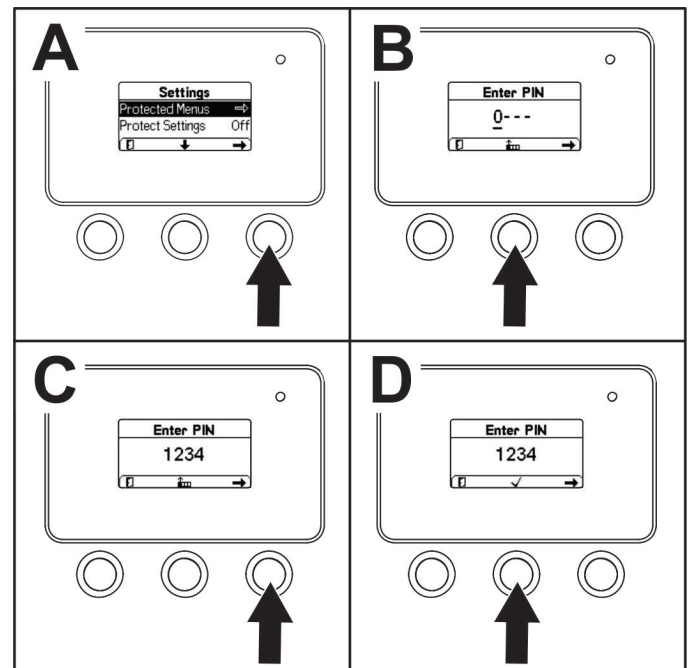

Figure 14

g264249

3. To enter the PIN code, press the center button until the correct first digit appears, then press the right button to move on to the next digit (Figure 14B and Figure 14C). Repeat this step until the last digit is entered and press the right button once more.
4. Press the middle button to enter the PIN code (Figure 14D).

Note: If the InfoCenter accepts the PIN code and the protected menu is unlocked, the word “PIN” displays in the upper right corner of the screen.

You can view and change the settings in the PROTECTED MENU. Once you access the PROTECTED MENU, scroll down to PROTECT SETTINGS option. Use the right button to change the setting. Setting the Protect Settings to OFF allows you to view and change the settings in the PROTECTED MENU without entering the PIN code. Setting the Protect Settings to ON hides the protected options and requires you to enter the PIN code to change the setting in the PROTECTED MENU.

After Operation

After Operation Safety

General Safety

- Shut off the machine, remove the key, wait for all movement to stop, and allow the machine to cool before adjusting, cleaning, storing, or servicing it.
- Clean debris from the attachments and drives to help prevent fires.
- Keep all parts in good working condition and all hardware tightened.
- Do not touch parts that may be hot from operation. Allow them to cool before attempting to maintain, adjust, or service the machine.
- Use care when loading or unloading the machine into a trailer or truck.

Battery and Charger Safety

General

- Improperly using or maintaining the battery charger could result in injury. To reduce this potential, comply with the all safety instructions.
- Use only the supplied charger for battery charging.
- Confirm the voltage that is available in your country before using the charger.
- For connection to a supply not in the US, use an attachment plug adapter of the proper configuration for the power outlet, if needed.
- Do not get the charger wet; keep it protected from rain and snow.
- A risk of fire, electric shock, or injury may result from using an accessory not recommended or sold by Toro.
- To reduce risk of a battery explosion, follow these instructions and the instructions for any equipment that you intend to use near the charger.
- Do not open batteries.
- In the event that a battery leaks, avoid contact with the liquid. If you accidentally come into contact with the liquid, flush with water and seek medical help. Liquid ejected from the battery may cause irritation or burns.
- Refer to an Authorized Service Dealer to service or replace a battery.

Training

- Never allow children or untrained people to operate or service the charger. Local regulations may restrict the age of the operator. The owner

is responsible for training all operators and mechanics.

- Read, understand, and follow all instructions on the charger and in the manual before operating the charger. Be familiar with the proper use of the charger.

Preparation

- Keep bystanders and children away while charging.
- Wear appropriate clothing while charging, including eye protection; long pants; and substantial, slip-resistant footwear.
- Shut off the machine and wait 5 seconds until the machine has completely powered down before charging. Failure to do this may cause arcing.
- Ensure that the area is well ventilated while charging.
- Read and follow all precautions for charging.
- The charger is for use only on nominal 120 and 240 VAC circuits, and is equipped with a grounding plug for 120 VAC operation. For use with 240 V circuits, contact your Authorized Toro Dealer for the correct power cord.

Operation

- Do not abuse the cord. Do not carry the charger by the cord or yank on the power supply cord to disconnect the charger from the receptacle. Keep the cord from heat, oil, and sharp edges.
- Connect the charger directly to a grounding (3-prong) receptacle. Do not use the charger on an ungrounded outlet, even with an adaptor.
- Do not alter the provided power cord or plug.
- Avoid dropping a metal tool near or onto a battery; it might cause a spark or short-circuit an electrical part that could lead to an explosion.
- Remove metal items such as rings, bracelets, necklaces, and watches when working with a lithium-ion battery. A lithium-ion battery can produce enough current to cause a severe burn.
- Never operate the charger without good visibility or light.
- Use an appropriate extension cord.
- If the power supply cord is damaged while it is plugged in, disconnect the cord from the wall receptacle and contact an Authorized Service Dealer for a replacement.
- Unplug the charger from the electrical outlet when not in use, before moving it to another location, or prior to servicing it.

Maintenance and Storage

- Store the charger indoors in a dry, secure place that is out of the reach of unauthorized users.
- Do not disassemble the charger. Take the charger to an Authorized Service Dealer when service or repair is required.
- Unplug the power cord from the outlet before starting any maintenance or cleaning to reduce risk of electric shock.
- Maintain or replace safety and instruction labels as needed.
- Do not operate the charger with a damaged cord or plug. Replace a damaged cord or plug immediately.
- If the charger has received an impact, been dropped, or otherwise damaged, do not use it; take it to an Authorized Service Dealer.

Moving a Non-Functioning Machine

Important: Do not tow or pull the machine without first opening the tow valves, or you will damage the hydraulic system.

1. Shut off the machine and remove the key.
2. Remove the plug covering each tow valve (Figure 15).

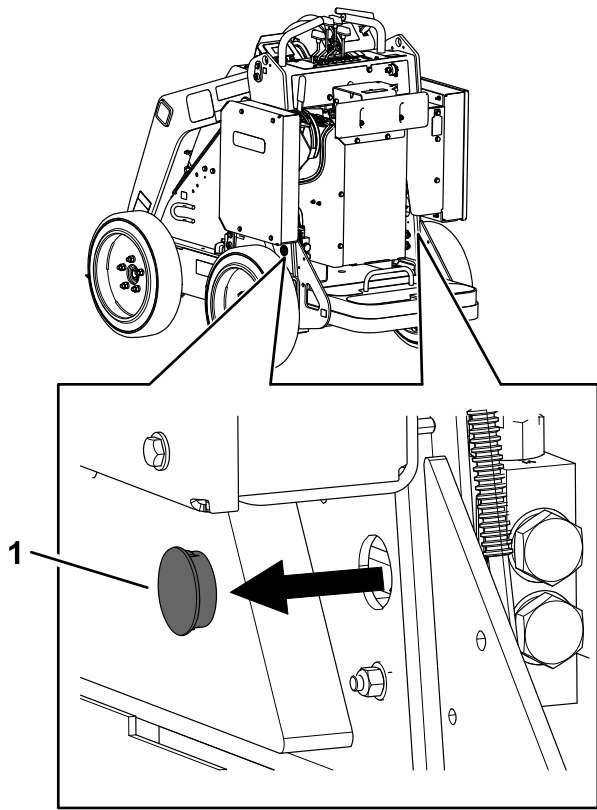

Figure 15

g304099

1. Plug

3. Loosen the jam nut on each tow valve.

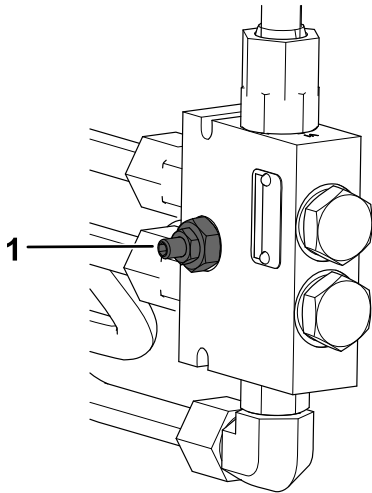

Figure 16

g304100

1. Tow valve

4. Turn each valve counterclockwise 1 turn with a hex wrench to open them.
5. Tow the machine as required.

Important: Do not exceed 4.8 km/h (3 mph) when towing.

6. After repairing the machine, close the tow valves and tighten the jam nuts.

Important: Do not overtighten the tow valves.

7. Replace the plugs.

Hauling the Machine

Use a heavy-duty trailer or truck to haul the machine. Use a full-width ramp. Ensure that the trailer or truck has all the necessary brakes, lighting, and marking as required by law. Please carefully read all the safety instructions. Knowing this information could help you or bystanders avoid injury. Refer to your local ordinances for trailer and tie-down requirements.

⚠ WARNING

Driving on the street or roadway without turn signals, lights, reflective markings, or a slow-moving-vehicle emblem is dangerous and can lead to accidents causing personal injury.

Do not drive the machine on a public street or roadway.

Selecting a Trailer

⚠ WARNING

Loading a machine onto a trailer or truck increases the possibility of tip-over and could cause serious injury or death (Figure 17).

- Use only full-width ramps.
- Ensure that the length of ramp is at least 4 times as long as the height of the trailer or truck bed to the ground. This ensures that ramp angle does not exceed 15 degrees on flat ground.

Loading the Machine

⚠ WARNING

Loading a machine onto a trailer or truck increases the possibility of tip-over and could cause serious injury or death.

- Use extreme caution when operating a machine on a ramp.
- Load and unload the machine with the heavy end up the ramp.
- Avoid sudden acceleration or deceleration while driving the machine on a ramp as this could cause a loss of control or a tip-over situation.

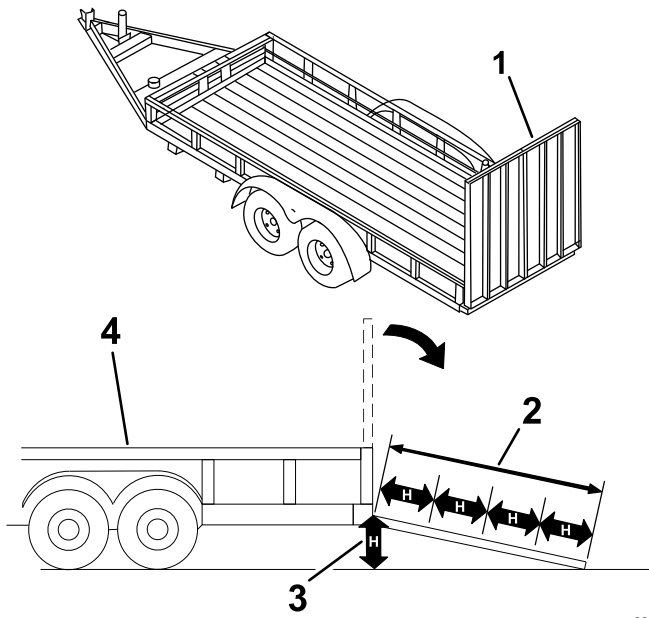
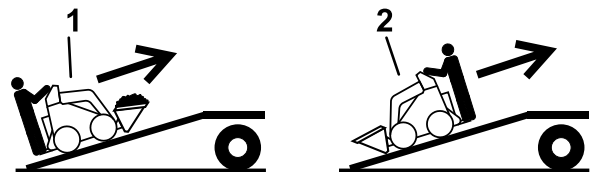

Figure 17

g229507

- | | |
|---|---|
| 1. Full-width ramp(s) in stowed position | 3. H=height of the trailer or truck bed to the ground |
| 2. Ramp is at least 4 times as long as the height of the trailer or truck bed to the ground | 4. Trailer |

1. If using a trailer, connect it to the towing vehicle and connect the safety chains.
2. If applicable, connect the trailer brakes.
3. Lower the ramp(s).
4. Lower the loader arms.
5. Load the machine onto the trailer with the heavy end up the ramp, carrying loads low (Figure 18).
 - If the machine has a **full** load-bearing attachment (e.g., bucket) or a non-load-bearing attachment (e.g., trencher), drive the machine forward up the ramp.
 - If the machine has an **empty** load-bearing attachment or no attachment, back the machine up the ramp.



g237904

Figure 18

1. Machine with full attachment or non-load-bearing attachment—drive the machine forward up the ramp(s).
2. Machine with empty or no attachment—back the machine up the ramp(s).

6. Lower the loader arms all the way down.
7. Engage the parking brake, shut off the machine, and remove the key.
8. Use the metal tie-down loops on the machine to securely fasten the machine to the trailer or truck with straps, chains, cable, or ropes (Figure 19). Refer to local regulations for tie-down requirements.

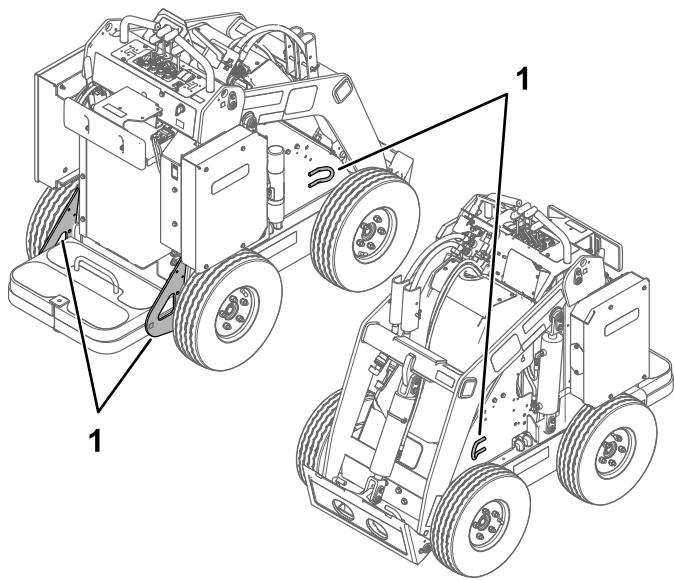

Figure 19

g304319

1. Tie-down loops

Unloading the Machine

1. Lower the ramp(s).
2. Unload the machine from the trailer with the heavy end up the ramp, carrying loads low (Figure 20).
 - If the machine has a **full** load-bearing attachment (e.g., bucket) or a non-load-bearing attachment (e.g., trencher), back it down the ramp.
 - If the machine has an **empty** load-bearing attachment or no attachment, drive it forward down the ramp.

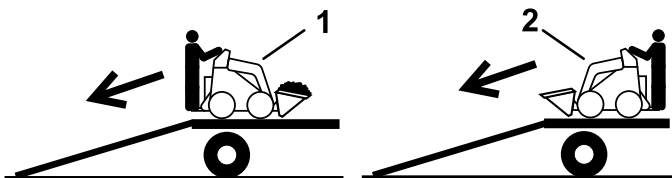

Figure 20

g237905

1. Machine with full attachment or non-load-bearing attachment—back the machine down the ramp(s).
2. Machine with empty or no attachment—drive the machine forward down the ramp(s).

Lifting the Machine

Lift the machine using the lift points (Figure 19).

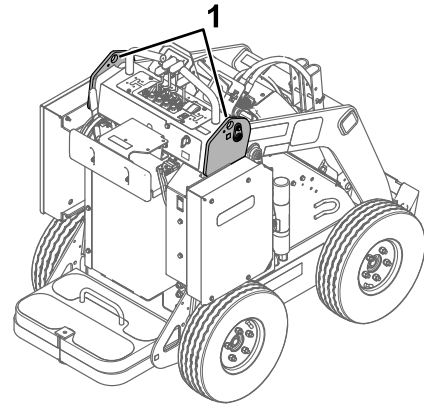

Figure 21

g305397

Maintaining the Batteries

⚠ WARNING

The batteries contains high voltage, which could burn or electrocute you.

- Do not attempt to open the batteries.
- Use extreme care when handling a battery with a cracked case.
- Use only the charger designed for the batteries.

The lithium-ion batteries hold a sufficient charge to perform intended work during its life span. As time goes by, the total amount of work that the batteries are able to complete on a single charge gradually diminishes.

Note: Your results may vary depending on the distance you need to transport the machine, the undulations that you travel across, and other factors as discussed in this section.

To achieve maximum life and use from your batteries, follow these guidelines:

- Do not open the battery. There are no user serviceable parts inside. If you open the pack, you will void your warranty. The batteries are protected by tamper-alerting devices.
- Store/park the machine in a clean, dry garage or storage area, **away from direct sunlight and heat sources**. Do not store it in a location where the temperature drops below -30°C (-22°F) or rises above 60°C (140°F). **Temperatures outside of this range will damage your batteries.** High temperatures during storage, especially at a high state of charge, reduces the life of the batteries.

- When storing the machine for more than 10 days, ensure that the machine is in a cool location, out of sunlight, and at least 50% charged.
- If you are operating the machine in hot conditions or in sunlight, the battery may overheat. If this happens, a high-temperature alert will appear on the InfoCenter. In this condition, the machine slows down.

Immediately drive the machine to a cool location out of the sun, turn off the machine, and allow the batteries to cool fully before resuming operation.

- If your machine is equipped with the Light Kit, shut off the lights when they are not in use.

Transporting the Batteries

The US Department of Transportation and international transportation authorities require that lithium ion batteries be transported using special packaging and only be transported by carriers certified to haul them. In the US, you are allowed to transport a battery when it is installed on the machine as battery powered equipment, with some regulatory requirements. Contact the US Department of Transportation or the appropriate government body in your country for detailed regulations on transportation of your batteries or the machine with the batteries equipped.

Contact your Authorized Toro Dealer for ways to ship or dispose of the batteries.

Using the Battery Charger

Refer to [Figure 22](#) for an overview of the battery-charger displays and cords.

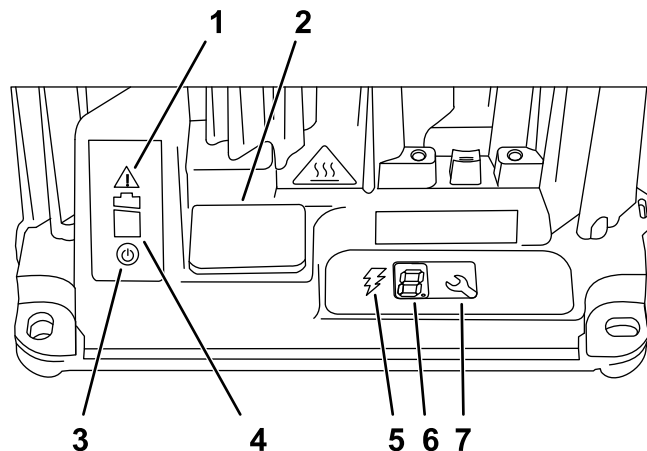

g251620

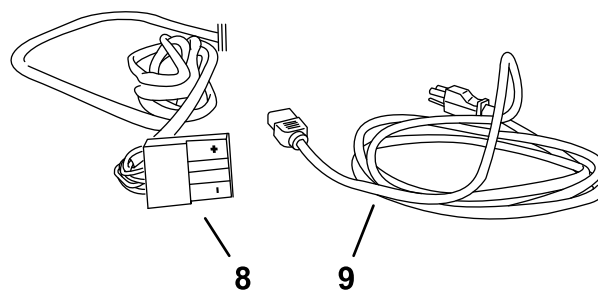

g251632

Figure 22

- | | |
|-------------------------------------|------------------------------|
| 1. Error indicator light | 6. LCD display |
| 2. USB port cover | 7. Select button |
| 3. AC Power indicator light | 8. Output connector and cord |
| 4. Battery-charging indicator light | 9. Power-supply cord |
| 5. Charging-output indicator light | |

Connecting to a Power Source

To reduce the risk of electric shock, this charger has a 3-prong grounded plug (type B). If the plug does not fit into the wall receptacle, other grounded plug types are available; contact an Authorized Toro Dealer.

Do not change the charger or the power-supply-cord plug in any way.

⚠ DANGER

Contact with water while charging the machine could cause electric shock, causing injury or death.

Do not handle the plug or the charger with wet hands or while standing in water.

Important: Check the power supply cord periodically for holes or cracks in the insulation. Do not use a damaged cord. Do not run the cord through standing water or wet grass.

1. Insert the charger plug on the power-supply cord into the matching input power socket on the charger.

⚠ WARNING

A damaged charger cord can cause an electrical shock or a fire.

Thoroughly inspect the power supply cord before using the charger. If the cord is damaged, do not operate the charger until you obtain a replacement.

2. Insert the wall plug end of the power supply cord into a grounded electrical outlet.

Charging the Batteries

Important: Charge the batteries only in temperatures that are within the recommended range; refer to the following table for the recommended range:

Recommended Temperature Range for Charging

Charging range	0° to 45°C (32° to 113°F)
Low-temperature charging range (Reduced Current)	-5° to 0°C (23° to 32°F)
High-temperature charging range (Reduced Current)	45° to 60°C (113° to 140°F)

If the temperature is below -5°C (23°F), the batteries will not charge. If the temperature rises above -5°C (23°F), unplug the charger and plug it in again to charge the batteries.

1. Park the machine in the designated location for charging.
2. Engage the parking brake.
3. Shut off the machine and remove the key.
4. Ensure that the connectors are free of dust and debris.
5. Connect the charger power cord to a power source; refer to [Connecting to a Power Source](#) (page 25).
6. Slide the charger cover up and pivot it out of the way ([Figure 23](#)).

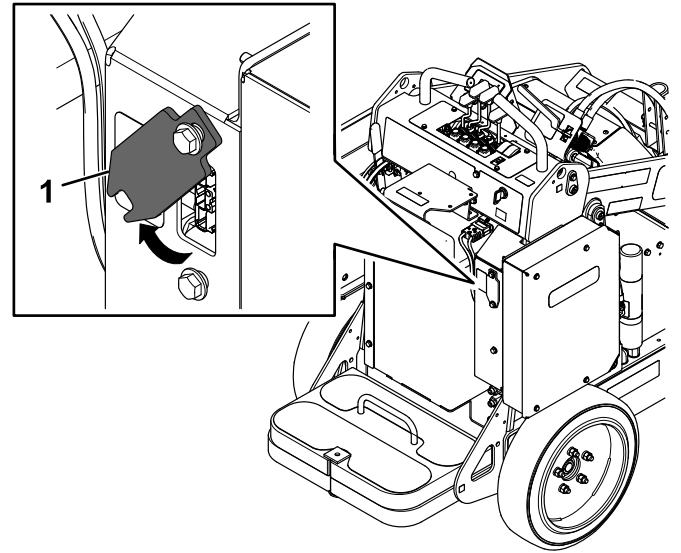

Figure 23

g304908

1. Charger cover

7. Plug the charger-output connector into the charger connector on the machine.

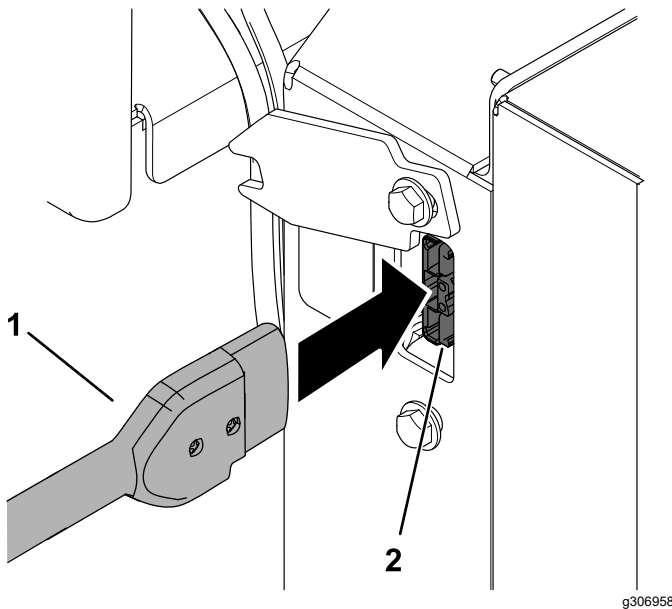

Figure 24

1. Charger-output connector 2. Machine charger connector

Monitoring the Charging Process and Troubleshooting

Note: The LCD status display displays messages during the course of charging. Most are routine.

If there is a fault, the error indicator light will flash amber or a solid, light red. An error message will appear in the InfoCenter 1 digit at a time, starting with the letter E or F (e.g., E-0-1-1).

To correct an error, refer to [Troubleshooting \(page 38\)](#). If none of these solutions correct the issue, contact an Authorized Service Dealer.

Completing the Charging Process

When charging is complete, the battery-charging indicator light ([Figure 22](#)) shows solid green and the machine InfoCenter displays 10 solid bars. Disconnect the charger connector from the machine connector.

8. Observe the charger to ensure that the batteries are charging.

Note: The battery-charging indicator light should flash and the charging-output indicator light should illuminate.

The machine amperage, displayed on the InfoCenter, increases while the batteries charge. If the amperage remains at 0, the batteries are not charging.

9. Disconnect the charger when the machine reaches a sufficient level; refer to [Completing the Charging Process \(page 26\)](#).
10. Pivot the charger cover in place and slide it down over the lower bolt ([Figure 23](#)).

Maintenance

Note: Determine the left and right sides of the machine from the normal operating position.

⚠ CAUTION

If you leave the key in the switch, someone could accidentally start the machine and seriously injure you or other bystanders.

Remove the key from the switch and disconnect the power before you perform any maintenance.

Maintenance Safety

- Park the machine on a level surface, disengage the auxiliary hydraulics, lower the attachment, engage the parking brake, shut off the machine, and remove the key. Wait for all movement to stop and allow the machine to cool before adjusting, cleaning, storing, or repairing it.
- Do not allow untrained personnel to service the machine.
- Use jack stands to support the components when required.
- Carefully release pressure from components with stored energy; refer to [Relieving Hydraulic Pressure \(page 33\)](#).
- Disconnect the battery before making any repairs; refer to [Disconnecting the Main Power \(page 29\)](#).
- Keep your hands and feet away from the moving parts. If possible, do not make adjustments with the machine running.
- Keep all parts in good working condition and all hardware tightened. Replace all worn or damaged decals.
- Do not tamper with the safety devices.
- Use only Toro-approved attachments. Attachments can change the stability and the operating characteristics of the machine. You may void the warranty if you use the machine with unapproved attachments.
- Use only genuine Toro replacement parts.
- If any maintenance or repair requires the loader arms to be in the raised position, secure the arms in the raised position with the hydraulic-cylinder lock(s).

Recommended Maintenance Schedule(s)

Maintenance Service Interval	Maintenance Procedure
After the first 8 hours	<ul style="list-style-type: none"> • Torque the wheel-lug nuts. • Replace the hydraulic filter.
Before each use or daily	<ul style="list-style-type: none"> • Grease the machine. (Grease immediately after every washing.) • Check the static strap; replace it if worn or missing. • Check the tire treads. • Test the parking brake. • Remove debris from the machine. • Check for loose fasteners.
Every 25 hours	<ul style="list-style-type: none"> • Check the hydraulic lines for leaks, loose fittings, kinked lines, loose mounting supports, wear, weather, and chemical deterioration. • Check the hydraulic-fluid level.
Every 100 hours	<ul style="list-style-type: none"> • Torque the wheel-lug nuts.
Every 400 hours	<ul style="list-style-type: none"> • Replace the hydraulic filter.
Every 1,500 hours or 2 years, whichever comes first	<ul style="list-style-type: none"> • Replace all moving hydraulic hoses.
Yearly	<ul style="list-style-type: none"> • Change the hydraulic fluid.
Yearly or before storage	<ul style="list-style-type: none"> • Touch up chipped paint.

Pre-Maintenance Procedures

Using the Cylinder Locks

⚠ WARNING

The loader arms may lower when in the raised position, crushing anyone under them.

Install the cylinder lock(s) before performing maintenance that requires raised loader arms.

Installing the Cylinder Locks

1. Remove the attachment.
2. Raise the loader arms to the fully raised position.
3. Shut off the machine and remove the key.
4. Position a cylinder lock over each lift-cylinder rod (Figure 25).

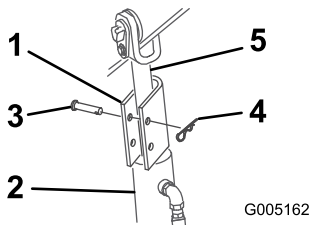

Figure 25

1. Cylinder lock
2. Lift cylinder
3. Hairpin cotter
4. Clevis pin
5. Lift-cylinder rod

5. Secure each cylinder lock with a clevis pin and cotter pin (Figure 25).
6. **Slowly** lower the loader arms until the cylinder locks contact the cylinder bodies and rod ends.

Removing and Storing the Cylinder Locks

Important: Remove the cylinder locks from the rods and fully secure them in the storage position before operating the machine.

1. Start the machine.
2. Raise the loader arms to the fully raised position.
3. Shut off the machine and remove the key.
4. Remove the clevis pin and cotter pin securing each cylinder lock.
5. Remove the cylinder locks.

6. Lower the loader arms.
7. Install the cylinder locks over the hydraulic hoses and secure them with the clevis pins and cotter pins (Figure 26).

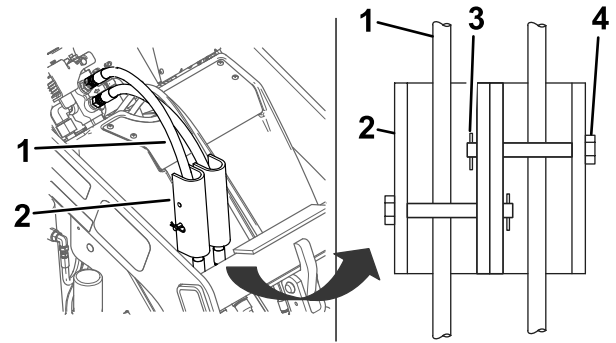

Figure 26

1. Hydraulic hoses
2. Cylinder locks
3. Hairpin cotter
4. Clevis pin

Accessing Internal Components

⚠ WARNING

Opening or removing covers, hoods, and screens while the machine is running could allow you to contact moving parts, seriously injuring you.

Before opening any of the covers, hoods, and screens, shut off the machine, remove the key from the key switch, and allow the machine to cool.

Removing the Hood

Note: If you need to access the main-power connectors or fuse but cannot safely raise the loader arms to remove the hood, refer to [Removing the Front Cover \(page 29\)](#) for access.

1. Park the machine on a level surface.
2. Raise the loader arms and install the cylinder locks.

Note: If you cannot raise the loader arms using the machine power, pull the loader-arm lever rearward and use a hoist to lift the loader arms.

3. Shut off the machine and remove the key.
4. Loosen the 4 nuts securing the hood (Figure 27).

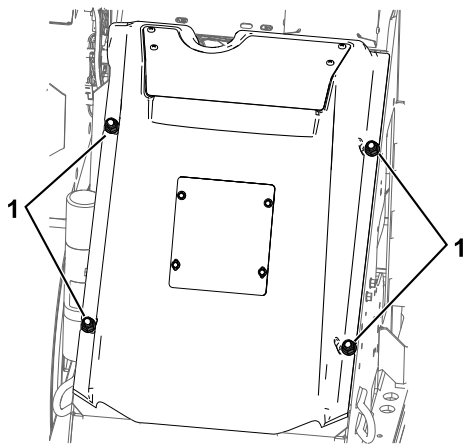

Figure 27

g304438

1. Nuts

5. Pull the hood off the machine.

Removing the Front Cover

Important: Remove the front cover to access the main-power connectors and fuse only when you are unable to safely raise the loader arms to remove the hood.

1. Park the machine on a level surface, lower the loader arms, and engage the parking brake.
2. Shut off the machine and remove the key.
3. Remove the 4 bolts securing the front cover and remove the cover (Figure 28).

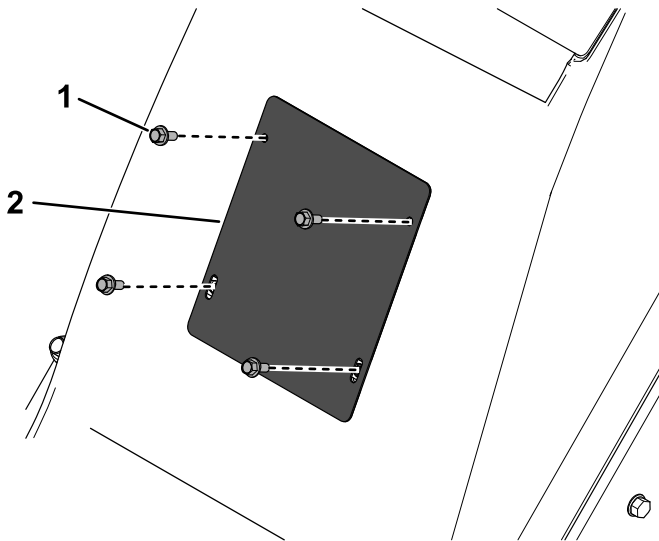

Figure 28

g304727

1. Bolt (4)

2. Front cover

Disconnecting the Main Power

Before you service the machine, disconnect the machine from the power supply by separating the main-power connectors (Figure 29).

1. Park the machine on a level surface.
2. Raise the loader arms and install the cylinder locks.
3. Shut off the machine and remove the key.
4. Remove the hood; refer to [Removing the Hood \(page 28\)](#).
5. Separate the 2 power connectors (Figure 29).
6. Make any repairs.
7. Plug the connectors together before operating the machine.

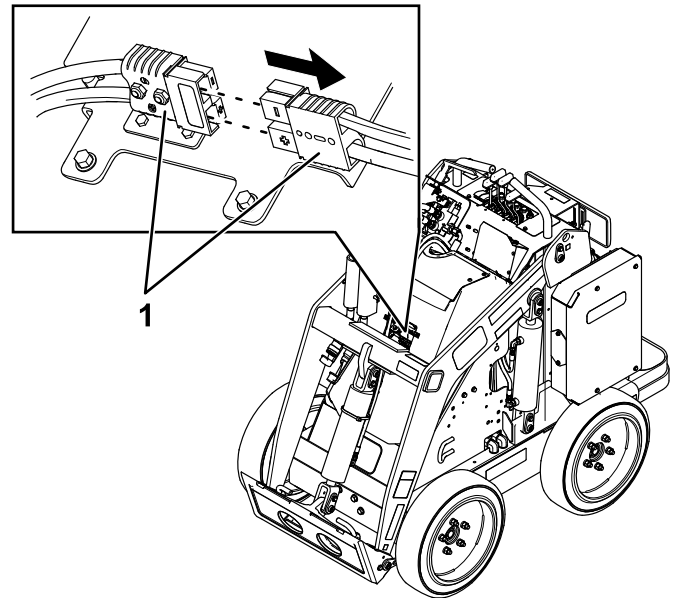

Figure 29

g304040

1. Main-power connectors

⚠ CAUTION

If you do not disconnect the power to the machine, someone could accidentally turn on the machine, causing serious bodily injury.

Always separate the connectors before working on the machine.

Lubrication

Greasing the Machine

Service Interval: Before each use or daily (Grease immediately after every washing.)

Grease Type: General-purpose grease

1. Park the machine on a level surface, lower the loader arms, and engage the parking brake.
2. Shut off the machine and remove the key.
3. Clean the grease fittings with a rag.
4. Connect a grease gun to each fitting ([Figure 30](#) and [Figure 31](#)).

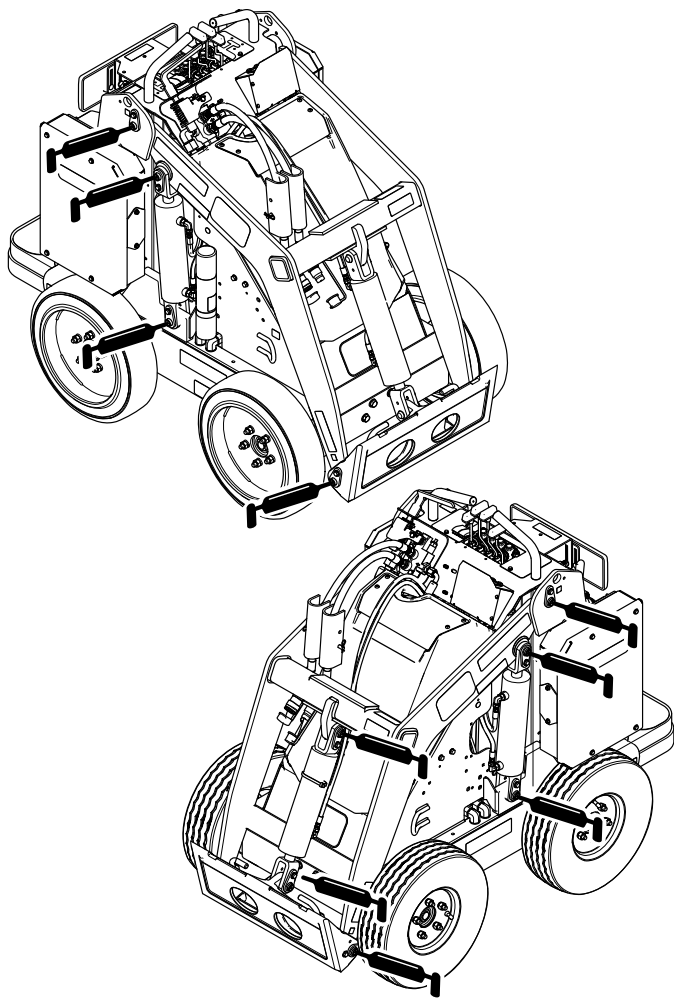
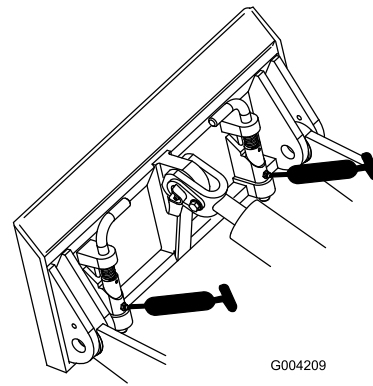

Figure 30

g304444



G004209

g004209

Figure 31

5. Pump grease into the fittings until grease begins to ooze out of the bearings (approximately 3 pumps).
6. Wipe up any excess grease.

Electrical System Maintenance

Electrical System Safety

- Disconnect the main-power connectors before repairing the machine.
- Charge the battery in an open, well-ventilated area, away from sparks and flames. Unplug the charger before connecting or disconnecting the battery. Wear protective clothing and use insulated tools.

Disconnecting or Connecting Power to the Machine

The main-power connectors provide power from the batteries to the machine. Disconnect the power by separating the connectors; connect the power by installing the connectors together. Refer to [Disconnecting the Main Power \(page 29\)](#).

Replacing the Static Strap

Service Interval: Before each use or daily—Check the static strap; replace it if worn or missing.

1. Park the machine on a level surface, lower the loader arms, and engage the parking brake.
2. Shut off the machine and remove the key.
3. Under the platform, replace the static strap as shown in [Figure 32](#).

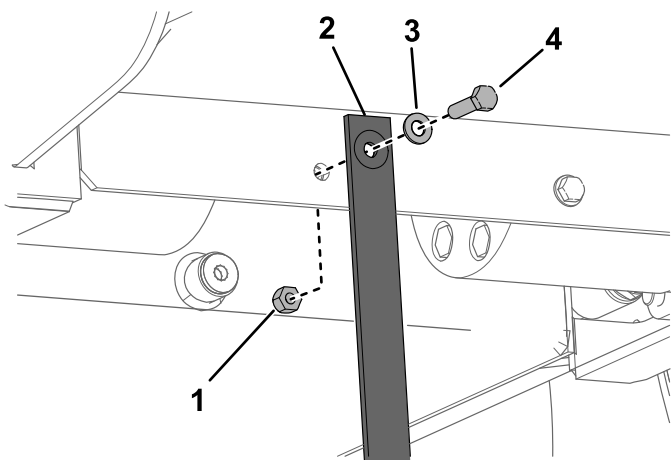

Figure 32

- | | |
|-----------------|-----------|
| 1. Nut | 3. Washer |
| 2. Static strap | 4. Bolt |

Servicing the Batteries

Note: The machine is equipped with 7 lithium-ion batteries.

If you attempt to open the main compartment of a battery, you will void your warranty. If a battery requires service, contact your Authorized Service Dealer for assistance.

Dispose of or recycle lithium-ion batteries in accordance with local and federal regulations.

Maintaining the Battery Charger

Important: All electrical repairs should be performed by an Authorized Service Dealer only.

The operator can perform very little maintenance other than protecting the charger from damage and weather.

Maintaining the Battery-Charger Cords

- Clean the cords with a slightly damp cloth after each use.
- Coil the cords when not in use.
- Periodically examine the cords for damage, and replace them when necessary with Toro-approved parts.

Cleaning the Battery-Charger Case

Clean the case with a slightly damp cloth after each use.

Servicing the Fuse

1. Park the machine on a level surface.
2. Raise the loader arms and install the cylinder locks.
3. Shut off the machine and remove the key.
4. Remove the hood; refer to [Removing the Hood \(page 28\)](#).
5. Disconnect the main power to the machine; refer to [Disconnecting the Main Power \(page 29\)](#).
6. Locate the fuse and replace it ([Figure 33](#)).

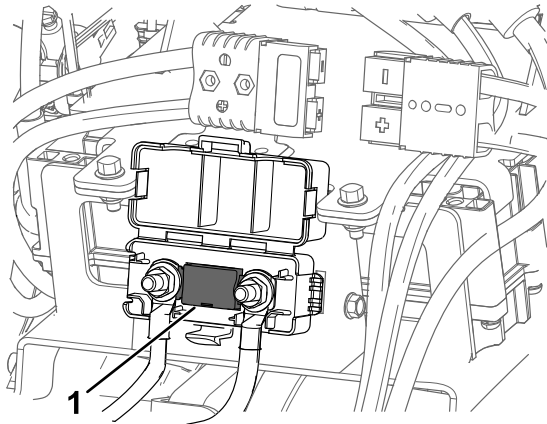

Figure 33

g304512

Drive System Maintenance

Checking the Tire Treads

Service Interval: Before each use or daily

Check the tire treads for wear. Replace the tires when the treads are worn and shallow.

Checking the Wheel-Lug Nuts

Service Interval: After the first 8 hours

Every 100 hours

Check and torque the wheel lug nuts to 68 N·m (50 ft-lb).

-
7. Torque the nuts to 12 to 18 N·m (9 to 13 ft-lb).
 8. Connect the main-power connectors.
 9. Install the front cover.

Brake Maintenance

Testing the Parking Brake

Service Interval: Before each use or daily

1. Engage the parking-brake; refer to [Parking-Brake Lever \(page 10\)](#).
2. Start the machine.
3. Slowly attempt to drive the machine forward or rearward.

Note: The machine may move some before the parking brake locks in place.

4. If the machine moves without the parking brake locking in place, contact your Authorized Service Dealer for service.

Hydraulic System Maintenance

Hydraulic System Safety

- Seek immediate medical attention if fluid is injected into skin. Injected fluid must be surgically removed within a few hours by a doctor.
- Ensure that all hydraulic-fluid hoses and lines are in good condition and all hydraulic connections and fittings are tight before applying pressure to the hydraulic system.
- Keep your body and hands away from pinhole leaks or nozzles that eject high-pressure hydraulic fluid.
- Use cardboard or paper to find hydraulic leaks.
- Safely relieve all pressure in the hydraulic system before performing any work on the hydraulic system.

Relieving Hydraulic Pressure

To relieve hydraulic pressure while the machine is on, disengage the auxiliary hydraulics and fully lower the loader arms.

To relieve the pressure while the machine is off, move the auxiliary-hydraulics lever between the forward and reverse flow positions to relieve auxiliary hydraulic pressure, move the attachment-tilt lever forward and rearward, and move the loader-arm lever forward to lower the loader arms ([Figure 34](#)).

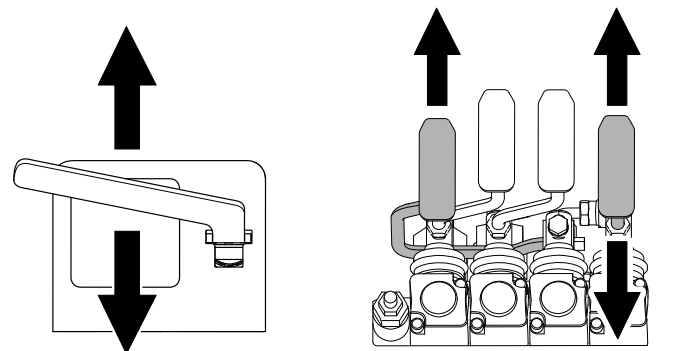

Figure 34

g281214

Hydraulic Fluid Specifications

Hydraulic Tank Capacity: 56 L (14.8 US gallons)

Use only 1 of the following fluids in the hydraulic system:

- **Toro Premium Transmission/Hydraulic Tractor Fluid** (refer to your Authorized Service Dealer for more information)
- **Toro PX Extended Life Hydraulic Fluid** (refer to your Authorized Service Dealer for more information)
- If either of the above Toro fluids are not available, you may use another Universal Tractor Hydraulic Fluid (UTHF), but they must be only conventional, petroleum-based products. The specifications must fall within the listed range for all the following material properties and the fluid should meet the listed industry standards. Check with your hydraulic fluid supplier to determine if the fluid meets these specifications.

Note: Toro will not assume responsibility for damage caused by improper substitutions, so use only products from reputable manufacturers who will stand behind their recommendations.

Material Properties	
Viscosity, ASTM D445	cSt at 40°C: 55 to 62
	cSt at 100°C: 9.1 to 9.8
Viscosity index, ASTM D2270	140 to 152
Pour Point, ASTM D97	-43 to -37°C (-46 to -35°F)
Industry Standards	
API GL-4, AGCO Powerfluid 821 XL, Ford New Holland FNHA-2-C-201.00, Kubota UDT, John Deere J20C, Vickers 35VQ25 and Volvo WB-101/BM	

Note: Many hydraulic fluids are almost colorless, making it difficult to spot leaks. A red dye additive for the hydraulic system fluid is available in 20 ml (0.67 fl oz) bottles. One bottle is sufficient for 15 to 22 L (4 to 6 US gallons) of hydraulic fluid. Order Part No. 44-2500 from your Authorized Service Dealer.

Checking the Hydraulic-Fluid Level

Service Interval: Every 25 hours

Check the hydraulic-fluid level before the machine is first started and after every 25 operating hours.

Refer to [Hydraulic Fluid Specifications \(page 34\)](#).

Important: Always use the correct hydraulic fluid. Unspecified fluids will damage the hydraulic system.

1. Park the machine on a level surface, remove any attachment, engage the parking brake, raise the loader arms, and install the cylinder locks.
2. Shut off the machine, remove the key, and allow the machine to cool.
3. Remove the hood/front access cover.
4. Clean the area around the filler neck of the hydraulic tank ([Figure 35](#)).
5. Remove the filler-neck cap and check the fluid level on the dipstick ([Figure 35](#)).

The fluid level should be between the marks on the dipstick.

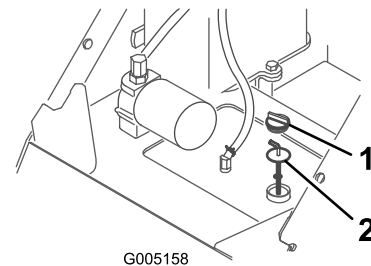

Figure 35

1. Filler neck cap
2. Dipstick

6. If the level is low, add enough fluid to raise it to the proper level.
7. Install the filler-neck cap.
8. Install the hood/front access cover.
9. Remove and store the cylinder locks and lower the loader arms.

Replacing the Hydraulic Filter

Service Interval: After the first 8 hours

Every 400 hours

Important: Do not substitute an automotive oil filter; otherwise, severe hydraulic system damage may result.

1. Park the machine on a level surface, remove any attachment, engage the parking brake, raise the loader arms, and install the cylinder locks.
2. Shut off the machine and remove the key.
3. Remove the hood.
4. Place a drain pan under the filter.
5. Remove the old filter (Figure 36) and wipe the surface of the filter adapter clean.

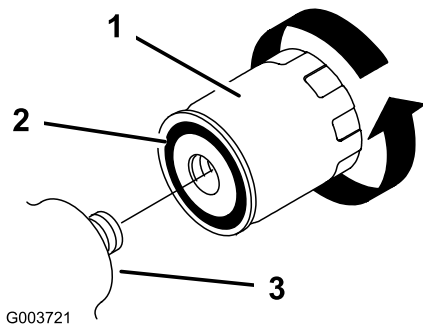

Figure 36

1. Hydraulic filter
2. Gasket
3. Filter adapter

6. Apply a thin coat hydraulic fluid to the rubber gasket on the replacement filter (Figure 36).
7. Install the replacement hydraulic filter onto the filter adapter (Figure 36). Tighten it clockwise until the rubber gasket contacts the filter adapter, then tighten the filter an additional 1/2 turn.
8. Clean up any spilled fluid.
9. Start the machine and let it run for about 2 minutes to purge air from the system.
10. Shut off the machine and check for leaks.
11. Check the fluid level in the hydraulic tank; refer to [Checking the Hydraulic-Fluid Level \(page 34\)](#). Add fluid to raise the level to mark on dipstick. Do not overfill the tank.
12. Install the hood.
13. Remove and store the cylinder locks and lower the loader arms.

Changing the Hydraulic Fluid

Service Interval: Yearly

1. Park the machine on a level surface, remove any attachment, engage the parking brake, raise the loader arms, and install the cylinder locks.
2. Shut off the machine and remove the key.
3. Remove the hood.
4. Place a large drain pan under the machine that can hold at least 61 L (16 US gallons).
5. Remove the drain plug from the bottom of the hydraulic tank and allow the fluid to completely drain out (Figure 37).

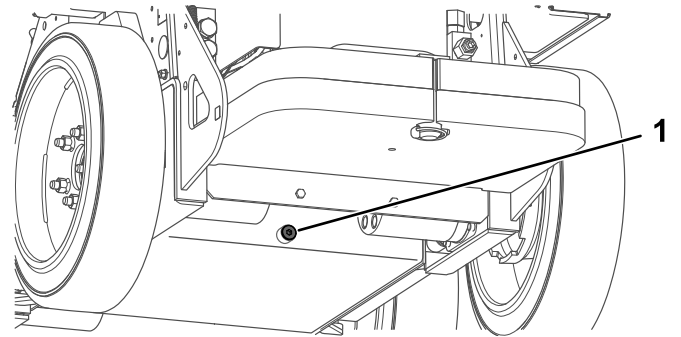

Figure 37

1. Drain plug

6. Install the drain plug.
7. Fill the hydraulic tank with hydraulic fluid; refer to [Hydraulic Fluid Specifications \(page 34\)](#).

Note: Dispose of used fluid at a certified recycling center.

8. Install the hood.
9. Remove and store the cylinder locks and lower the loader arms.

Cleaning

Removing Debris

Service Interval: Before each use or daily

1. Park the machine on a level surface, lower the loader arms, and engage the parking brake.
2. Shut off the machine and remove the key.
3. Clean any debris from the machine.

Important: Blow the dirt out rather than wash it out. If you use water, keep it away from electrical items and hydraulic valves.

4. Remove and store the cylinder locks and lower the loader arms.

Washing the Machine

When pressure washing the machine, do the following:

- Wear appropriate personal protective equipment for the pressure washer.
- Keep all guards in place on the machine.
- Avoid spraying at electronic components.
- Avoid spraying at edges of decals.
- Spray the exterior of the machine only. Do not spray directly into openings in the machine.
- Spray only the dirty parts of the machine.
- Use a 40-degree or larger spray nozzle. 40-degree nozzles are usually white.
- Keep the tip of the pressure washer at least 61 cm (2 ft) away from the surface being washed.
- Use only pressure washers with pressure below 13790 kpa (2000 psi) and flow below 7.6 L (2 US gallons) per minute.
- Replace damaged or peeling decals.
- Grease all grease points after washing; refer to [Greasing the Machine \(page 30\)](#).

Storage

Storage Safety

- Shut off the machine, remove the key, wait for all moving parts to stop, and allow the machine to cool before storing it.
- Do not store the machine near flames.

Storing the Machine

1. Park the machine on a level surface, lower the loader arms, and engage the parking brake.
2. Shut off the machine and remove the key.
3. Remove dirt and grime from the external parts of the entire machine.

Important: Wash the machine using mild detergent and water. Avoid excessive use of water, especially near the control panel, hydraulic pumps, and motors.

4. Grease the machine; refer to [Greasing the Machine \(page 30\)](#).
5. Torque the wheel lug nuts; refer to [Checking the Wheel-Lug Nuts \(page 32\)](#).
6. Check the hydraulic fluid level; refer to [Checking the Hydraulic-Fluid Level \(page 34\)](#).
7. Check and tighten all fasteners. Repair or replace any worn, damaged, or missing parts.
8. Paint all scratched or bare metal surfaces with paint available from your Authorized Service Dealer.
9. Store the machine in a clean, dry garage or storage area. Remove the key from the key switch and keep it in a memorable place.
10. For prolonged storage, follow the battery storage requirements; refer to [Battery Storage Requirements \(page 36\)](#).
11. Cover the machine to protect it and keep it clean.

Battery Storage Requirements

Note: You do not need to remove the batteries from the machine for storage.

Important: Temperatures outside of this range will damage your batteries.

The temperature that the batteries are stored at will affect their long-term life. Storage for long periods of time at high temperatures will reduce the battery life. Store the machine in a cool (not below freezing) location.

Temperature Requirements for Storage

Storage Conditions	Temperature Requirement
Normal storage conditions	-20° to 45°C (-12° to 113°F)
Extreme heat—1 month or less	45° to 60°C (113° to 140°F)
Extreme cold—3 months or less	-30° to -20°C (-22° to -12°F)

- For storage of **1 to 6 months**, charge or discharge the batteries to 50%.

Note: A 50% charge will maximize the battery life more than a 100% charge.

- For storage of **6 months or more**, charge the batteries to 100%.

Note: This ensures that the batteries do not discharge to below 50% during storage.

- For storage of **12 months or more**, ensure to check the charge every 6 months. If the charge is under 50%, you must charge the batteries to 100%.
- After charging the batteries, disconnect the battery charger from power. Disconnect the main connector during storage to minimize the discharging of the batteries.
- If you leave the charger on the machine, it will shut off after the batteries are fully charged and does not turn back on unless the charger is disconnected and reconnected.

Troubleshooting

Machine Troubleshooting

Problem	Possible Cause	Corrective Action
The machine does not drive.	<ol style="list-style-type: none"> 1. The parking brake is engaged. 2. The hydraulic-fluid level is low. 3. The hydraulic system is damaged. 	<ol style="list-style-type: none"> 1. Disengage the parking brake. 2. Add hydraulic fluid to the reservoir. 3. Contact your Authorized Service Dealer.
When at rest, the loader arms lower more than 7.6 cm (3 inches) per hour (less than 7.6 cm or 3 inches an hour is normal for the machine).	<ol style="list-style-type: none"> 1. The valve spool is leaking. 	<ol style="list-style-type: none"> 1. Contact your Authorized Service Dealer.
When at rest, the loader arms lower 5 cm (2 inches) quickly and then stop.	<ol style="list-style-type: none"> 1. The cylinder seals are leaking. 	<ol style="list-style-type: none"> 1. Replace the seals.
The machine does not charge.	<ol style="list-style-type: none"> 1. The temperature is above 60°C (113°F) or below -5°C (23°F). 	<ol style="list-style-type: none"> 1. Charge the machine in conditions between -5°C (23°F) and 60°C (113°F).

Battery-Charger Error Codes

Problem	Possible Cause	Corrective Action
Code E-0-0-1, or E-0-4-7	<ol style="list-style-type: none"> 1. Battery high voltage 	<ol style="list-style-type: none"> 1. Ensure that the battery voltage is correct and the cable connections are secure; ensure that the battery is in good condition.
Code E-0-0-4	<ol style="list-style-type: none"> 1. BMS or battery fault detected 	<ol style="list-style-type: none"> 1. Contact an Authorized Toro Dealer.
Code E-0-0-7	<ol style="list-style-type: none"> 1. Battery amp hour limit exceeded 	<ol style="list-style-type: none"> 1. Possible causes include poor battery health, very deeply discharged battery, poorly connected battery, and/or high parasitic loads on battery while charging. Possible solutions: Replace batteries. Disconnect parasitic loads. This error will clear once the charger is reset by cycling DC.
Code E-0-1-2	<ol style="list-style-type: none"> 1. Reverse polarity error 	<ol style="list-style-type: none"> 1. The battery is connected to the charger incorrectly. Ensure that the battery connections are secure.
Code E-0-2-3	<ol style="list-style-type: none"> 1. High AC voltage error (>270VAC) 	<ol style="list-style-type: none"> 1. Connect charger to an AC source that provides stable AC between 85 - 270 VAC / 45-65 Hz.
Code E-0-2-4	<ol style="list-style-type: none"> 1. Charger failed to initialize 	<ol style="list-style-type: none"> 1. The charger has failed to turn on properly. Disconnect the AC input and battery connection for 30 seconds before retrying.
Code E-0-2-5	<ol style="list-style-type: none"> 1. Low AC voltage oscillation error 	<ol style="list-style-type: none"> 1. The AC source is unstable. Could be caused by undersized generator or severely undersized input cables. Connect charger to an AC source that provides stable AC between 85 - 270 VAC / 45-65 Hz.

Problem	Possible Cause	Corrective Action
Code E-0-3-7	1. Re-programming failed	1. Software upgrade failure or script operation failure. Ensure that the new software is correct.
Code E-0-2-9, E-0-3-0, E-0-3-2, E-0-4-6, or E-0-6-0	1. Communication error with battery	1. Ensure that the connection of the signal wires to the battery is secure.

Battery-Charger Fault Codes

Problem	Possible Cause	Corrective Action
F-0-0-1, F-0-0-2, F-0-0-3, F-0-0-4, F-0-0-5, F-0-0-6, or F-0-0-7	1. Internal charger fault	1. Remove the AC connection and battery connection for a minimum of 30 seconds and retry. If it fails again, please contact an Authorized Toro Dealer.

Notes:

Notes:

Notes:

EEA/UK Privacy Notice

Toro's Use of Your Personal Information

The Toro Company ("Toro") respects your privacy. When you purchase our products, we may collect certain personal information about you, either directly from you or through your local Toro company or dealer. Toro uses this information to fulfil contractual obligations - such as to register your warranty, process your warranty claim or to contact you in the event of a product recall - and for legitimate business purposes - such as to gauge customer satisfaction, improve our products or provide you with product information which may be of interest. Toro may share your information with our subsidiaries, affiliates, dealers or other business partners in connection these activities. We may also disclose personal information when required by law or in connection with the sale, purchase or merger of a business. We will never sell your personal information to any other company for marketing purposes.

Retention of your Personal Information

Toro will keep your personal information as long as it is relevant for the above purposes and in accordance with legal requirements. For more information about applicable retention periods please contact legal@toro.com.

Toro's Commitment to Security

Your personal information may be processed in the US or another country which may have less strict data protection laws than your country of residence. Whenever we transfer your information outside of your country of residence, we will take legally required steps to ensure that appropriate safeguards are in place to protect your information and to make sure it is treated securely.

Access and Correction

You may have the right to correct or review your personal data, or object to or restrict the processing of your data. To do so, please contact us by email at legal@toro.com. If you have concerns about the way in which Toro has handled your information, we encourage you to raise this directly with us. Please note that European residents have the right to complain to your Data Protection Authority.

California Proposition 65 Warning Information

What is this warning?

You may see a product for sale that has a warning label like the following:



WARNING: Cancer and Reproductive Harm—www.p65Warnings.ca.gov.

What is Prop 65?

Prop 65 applies to any company operating in California, selling products in California, or manufacturing products that may be sold in or brought into California. It mandates that the Governor of California maintain and publish a list of chemicals known to cause cancer, birth defects, and/or other reproductive harm. The list, which is updated annually, includes hundreds of chemicals found in many everyday items. The purpose of Prop 65 is to inform the public about exposure to these chemicals.

Prop 65 does not ban the sale of products containing these chemicals but instead requires warnings on any product, product packaging, or literature with the product. Moreover, a Prop 65 warning does not mean that a product is in violation of any product safety standards or requirements. In fact, the California government has clarified that a Prop 65 warning "is not the same as a regulatory decision that a product is 'safe' or 'unsafe.'" Many of these chemicals have been used in everyday products for years without documented harm. For more information, go to <https://oag.ca.gov/prop65/faqs-view-all>.

A Prop 65 warning means that a company has either (1) evaluated the exposure and has concluded that it exceeds the "no significant risk level"; or (2) has chosen to provide a warning based on its understanding about the presence of a listed chemical without attempting to evaluate the exposure.

Does this law apply everywhere?

Prop 65 warnings are required under California law only. These warnings are seen throughout California in a wide range of settings, including but not limited to restaurants, grocery stores, hotels, schools, and hospitals, and on a wide variety of products. Additionally, some online and mail order retailers provide Prop 65 warnings on their websites or in catalogs.

How do the California warnings compare to federal limits?

Prop 65 standards are often more stringent than federal and international standards. There are various substances that require a Prop 65 warning at levels that are far lower than federal action limits. For example, the Prop 65 standard for warnings for lead is 0.5 µg/day, which is well below the federal and international standards.

Why don't all similar products carry the warning?

- Products sold in California require Prop 65 labelling while similar products sold elsewhere do not.
- A company involved in a Prop 65 lawsuit reaching a settlement may be required to use Prop 65 warnings for its products, but other companies making similar products may have no such requirement.
- The enforcement of Prop 65 is inconsistent.
- Companies may elect not to provide warnings because they conclude that they are not required to do so under Prop 65; a lack of warnings for a product does not mean that the product is free of listed chemicals at similar levels.

Why does Toro include this warning?

Toro has chosen to provide consumers with as much information as possible so that they can make informed decisions about the products they buy and use. Toro provides warnings in certain cases based on its knowledge of the presence of one or more listed chemicals without evaluating the level of exposure, as not all the listed chemicals provide exposure limit requirements. While the exposure from Toro products may be negligible or well within the "no significant risk" range, out of an abundance of caution, Toro has elected to provide the Prop 65 warnings. Moreover, if Toro does not provide these warnings, it could be sued by the State of California or by private parties seeking to enforce Prop 65 and subject to substantial penalties.