



Count on it.

Parts Catalog

TRX-300

Trencher

Model No. 22984—Serial No. 407680000 and Up



Ordering Replacement Parts

To order replacement parts, please supply the part number, the quantity, and the description of each part desired.

Understanding Reference Numbers

Each identified part in an illustration has a reference number. The reference number for a part also appears in the parts list, along with other information about the part.

This catalog uses two special reference number formats, one to indicate parts in a service assembly and another to indicate the quantity of a given part in an illustration.

Service Assembly Reference Numbers

Parts in service assemblies have reference numbers in the form a:b. The a represents the reference number of the entire service assembly and the b represents a sequential number unique to each part within the service assembly.

For example, a wheel assembly might be identified by reference number 6, the tire by 6:1, the valve by 6:2, and the wheel by 6:3. When you order the assembly identified by reference number 6, you receive all parts identified by reference numbers 6:1, 6:2, and 6:3. However, you may also order any part individually. Reference numbers of this type appear in illustration and in parts lists.

Reference Numbers Indicating Quantity

In an illustration, if a reference number indicates more than one part, the reference number has the form nX y. The n represents the quantity of the part, the X is the multiplication symbol, and the y represents the reference number.

For example, in an illustration, the reference number 2X 37 means that two of the parts identified by reference number 37 are indicated.

Contents

Frame Assembly	4
Control Tower and Fuel Tank Assembly	6
Track Assembly	8
Brake Linkage Assembly	10
Engine and Muffler Assembly	12
Hydraulic Assembly	14
Hydraulic Motor Assembly No. 117-6306	16
Valve Assembly No. 137-7646	18
Valve Inlet Section Assembly No. 139-1337	20
Valve Inlet Section Assembly No. 139-1338	22
Series Valve Section Assembly No. 139-1339	24
Parallel Valve Section Assembly No. 139-1344	26
Series Valve Section Assembly No. 139-1345	28
Parallel Valve Section Assembly No. 139-1346	30
Outlet Section Assembly No. 139-1347	32
Oil Cooler Assembly	34
Trencher Head and Lift Assembly	36
Hydraulic Cylinder Assembly No. 137-3827	38
Control Assembly	40
Electrical Assembly	42
Wire Harness Assembly No. 137-7624	44
Attachments and Accessories	46

Frame Assembly

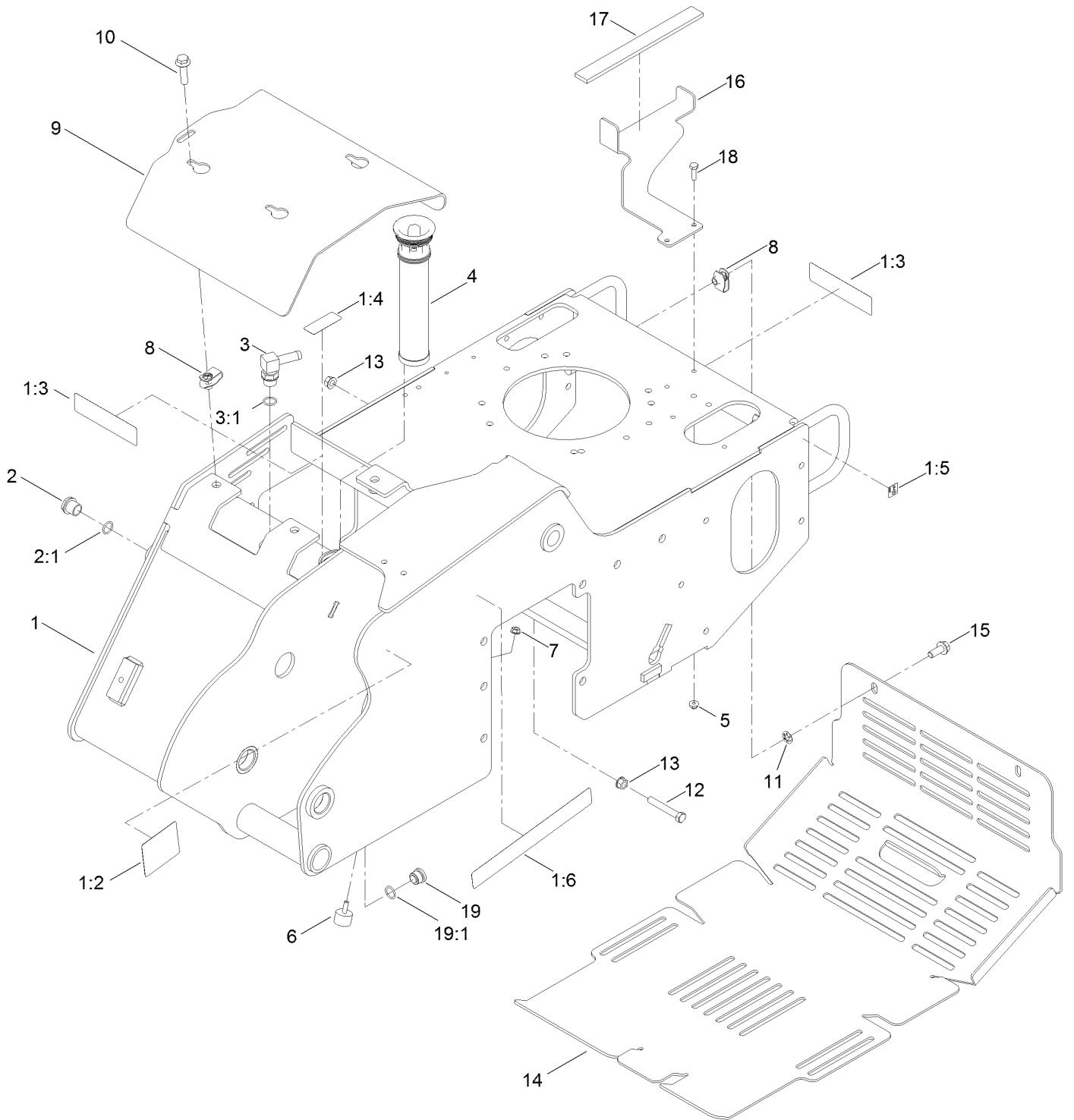

Frame Assembly (continued)

<i>Ref.</i>	<i>Part Number</i>	<i>Qty.</i>	<i>Description</i>	<i>Ref.</i>	<i>Part Number</i>	<i>Qty.</i>	<i>Description</i>
1	137-7628	1	Main Frame ASM	8	140-1146	5	Nut-Clip, U
1:2	100-4650	1	Decal-Warning	9	137-7623-03	1	Plate-Cover, Front
1:3	93-7814	2	Decal-Danger	10	33105-040	5	Screw-HHF
1:4	93-6686	1	Decal-Oil, HYD	11	140-1144	5	Nut-Push
1:5	93-9084	2	Decal-Point, Lift	12	323-12	1	Screw-HH
1:6	138-7103	1	Decal-Intellitrench	13	32128-40	2	Nut-Flange
2	114-3075	1	Sight Glass ASM	14	119-5106-01	1	Cover-Rear
2:1	237-79	1	O-Ring	15	108-1531	2	Screw-HHF
3	354-120	1	Fitting-Elbow, 90	16	119-5091-01	1	Bracket-Tank
3:1	237-79	1	O-Ring	17	117-6417	1	Pad-Foam
4	114-3039	1	Filter-Tank, In	18	321-5	2	Screw-HH
5	104-7201	2	Nut-HF	19	133-7659	1	Plug ASM
6	1-523420	1	Bumper	19:1	237-79	1	O-Ring
7	32128-33	1	Nut-HF				

Control Tower and Fuel Tank Assembly

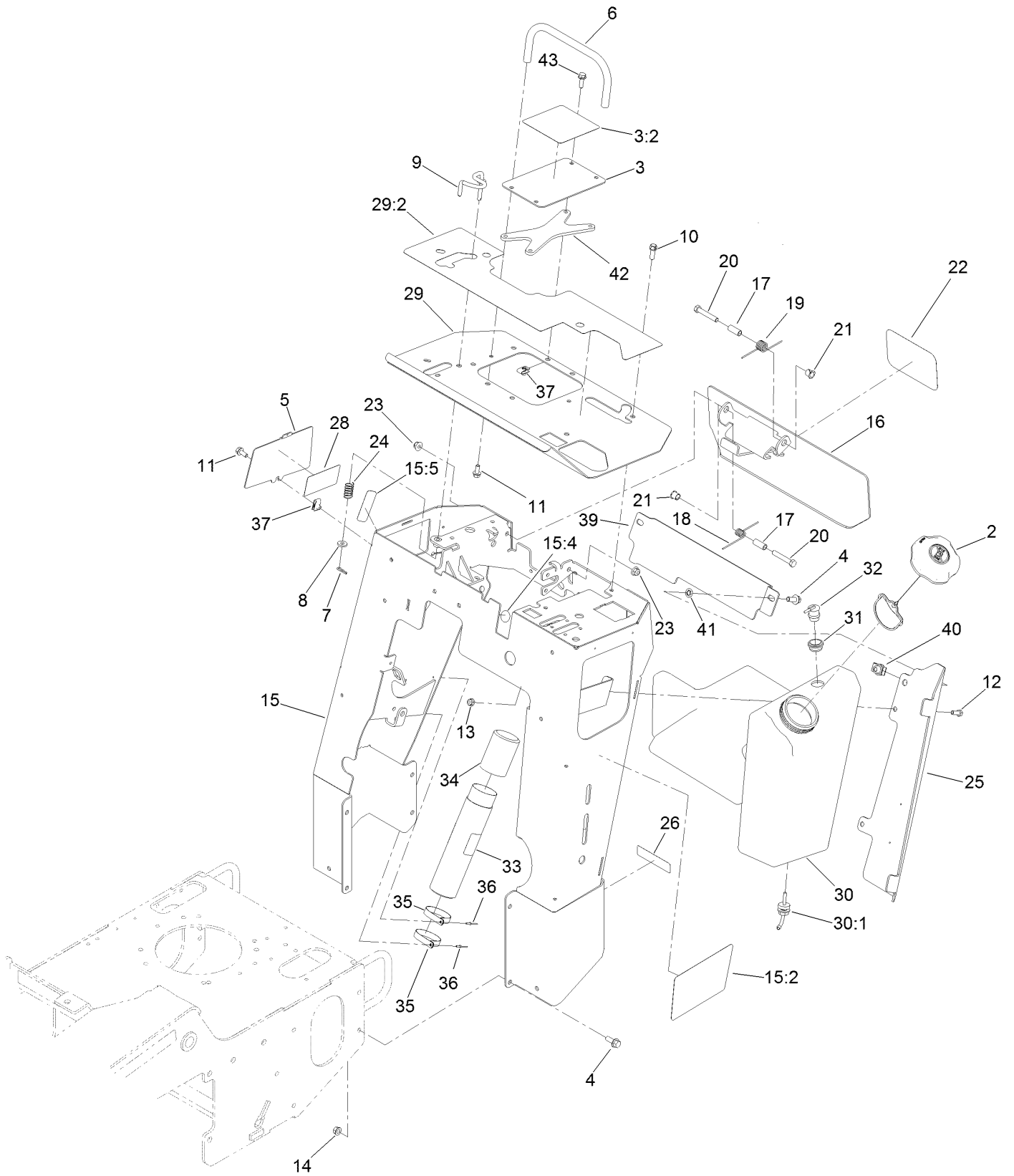

Control Tower and Fuel Tank Assembly (continued)

<i>Ref.</i>	<i>Part Number</i>	<i>Qty.</i>	<i>Description</i>	<i>Ref.</i>	<i>Part Number</i>	<i>Qty.</i>	<i>Description</i>
2	137-4119	1	Cap-Fuel, Ratcheting	21	256-257	2	Bushing-Nyliner
3	137-3795	1	Cover-Handle, Traction	22	105-1217	1	Decal
3:2	138-7107	1	Decal-Traction	23	104-8301	2	Nut-HF, NI
4	3234-11	10	Screw-HHF	24	85-6750	1	Spring-Control
5	137-7654-01	1	Plate-Cover, Access	25	119-5086-01	1	Bracket-Cover, Tank
6	137-7641	1	Bar-Reference	26	133-8062	1	Decal-Arrestor, Spark
7	3290-307	1	Pin-Cotter	28	138-7154	1	Decal-Fuse
8	88-7200	1	Washer-Flat	29	137-3799	1	Cover-Control
9	114-8727	1	Rod-Interlock	29:2	138-7106	1	Decal-Panel, Control
10	95-1726	4	Screw-Taptite	30	120-7359	1	Tank-Fuel
11	3234-5	3	Screw-HHF	30:1	103-2605	1	Fitting-Fuel, Bulkhead
12	322-4	2	Screw-HH	31	114-0284	1	Grommet
13	104-8300	2	Nut-HF, NI	32	119-3547	1	Valve-Vent, Fuel
14	32128-40	8	Nut-Flange	33	104-7050	1	Tube-Manual
15	137-3794	1	Control Tower ASM	34	104-7048	1	Cap-Housing
15:2	137-3839	1	Decal-Side, LH	35	2412-120	2	Clamp-R
15:4	107-8495	1	Decal-Brake, Parking	36	3269-17	2	Rivet-Pop
15:5	139-1271	1	Decal-Brake, Parking	37	94-2413	5	Nut-U
16	137-7652-03	1	Plate-Reverse	39	139-1259-03	1	Guard-Tower
17	114-1337	2	Spacer-Spring	40	105-4886	2	Nut-Tinnerman
18	98-8425	1	Spring-Torsion, LH	41	107-3154	2	Nut-Push
19	137-7695	1	Spring-Torsion	42	139-1288-03	1	Spacer-Cover
20	323-11	2	Screw-HH	43	3234-17	4	Screw-HHF

Track Assembly

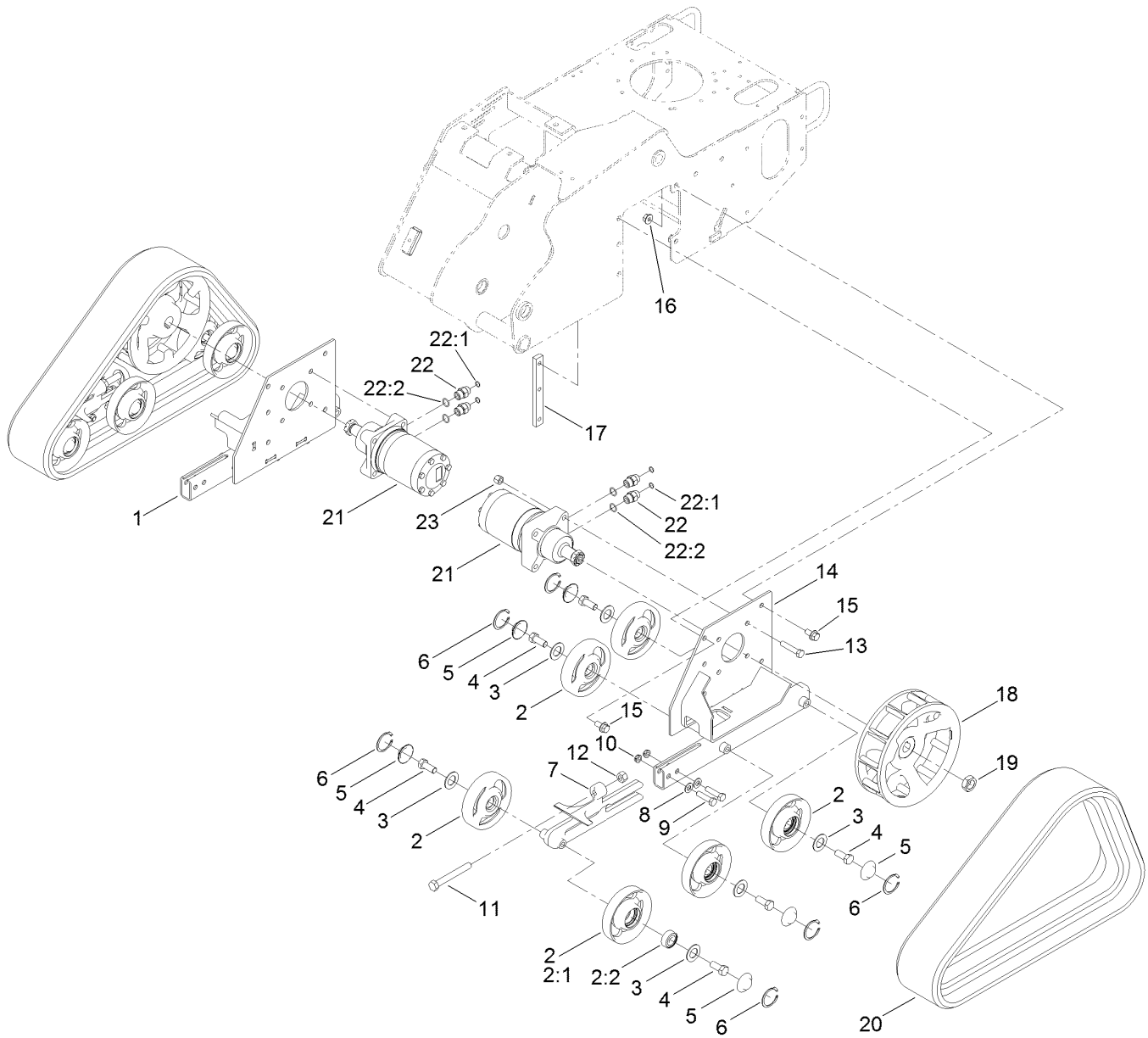

Track Assembly (continued)

<i>Ref.</i>	<i>Part Number</i>	<i>Qty.</i>	<i>Description</i>	<i>Ref.</i>	<i>Part Number</i>	<i>Qty.</i>	<i>Description</i>
1	114-2993-03	1	Frame-Track, RH	13	325-10	8	Screw-HH
2	138-3139	12	Tensioner Wheel ASM	14	114-2992-03	1	Frame-Track, LH
2:1	138-7118	1	Wheel-Track	15	3234-6	10	Screw-HHF
2:2	120-5378	1	Bearing-Ball	16	32128-49	4	Nut-HHF
3	106-7585	12	Gasket-Bogie	17	114-3091	2	Bar-Thread
4	327-4	12	Screw-HH	18	117-6426-03	2	Wheel-Drive
5	106-7557	12	Cap-Wheel, Bearing	19	106-8159	2	Nut-Lock
6	106-7595	12	Ring-Snap, Internal	20	112-4816	2	Track-Rubber
7	114-3077-03	2	Tensioner-Track	21	137-3866	2	Wheel Motor ASM
8	3256-26	4	Washer-Flat	22	340-6	4	Fitting-Straight
9	325-8	4	Screw-HH	22:1	237-30	1	O-Ring
10	3296-45	4	Nut-Hex	22:2	237-80	1	O-Ring
11	112-4874	2	Screw-HH, TAP	23	3296-23	8	Nut-Lock, NI
12	3217-11	2	Nut-Hex				

Brake Linkage Assembly

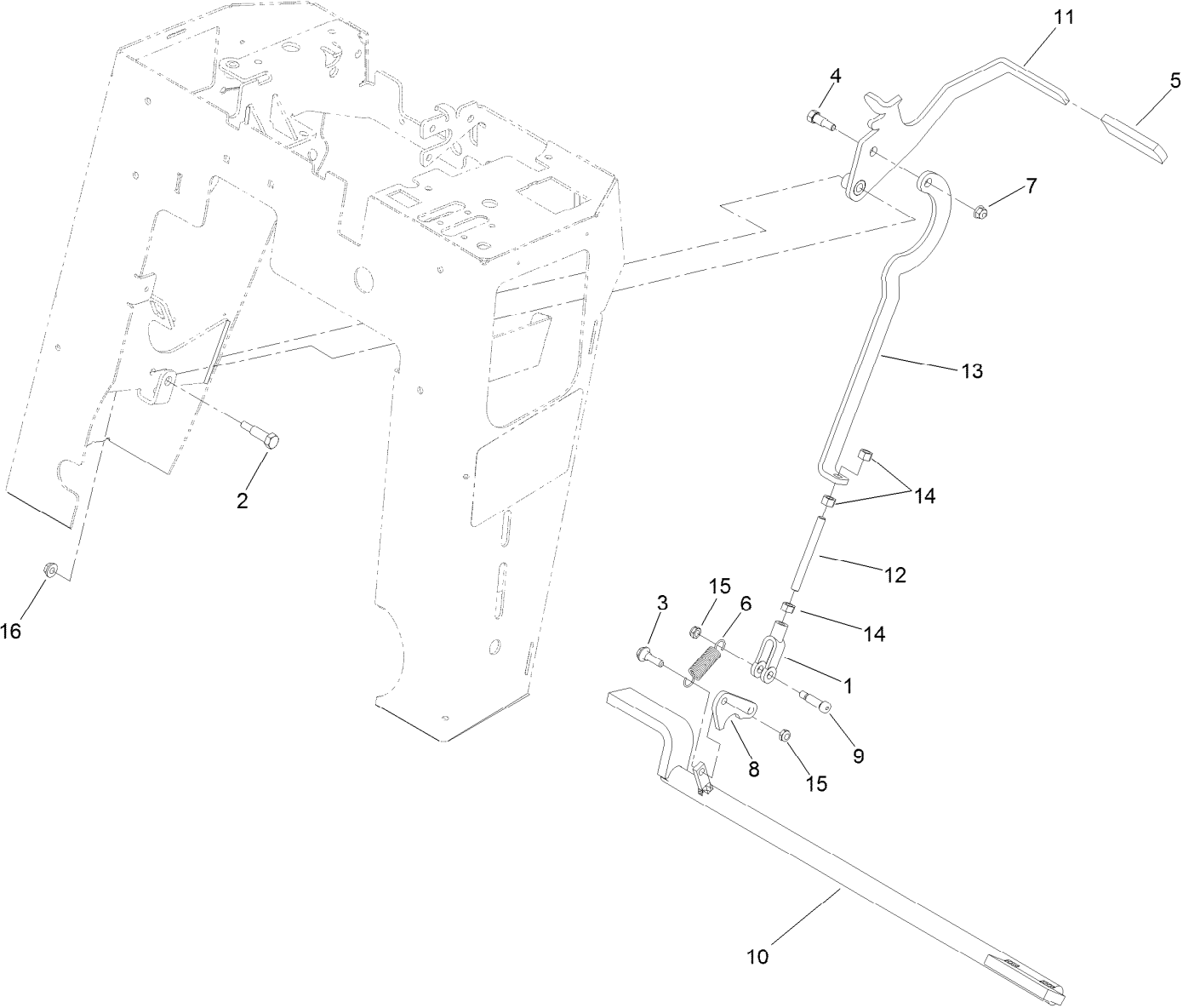

Brake Linkage Assembly (continued)

<i>Ref.</i>	<i>Part Number</i>	<i>Qty.</i>	<i>Description</i>	<i>Ref.</i>	<i>Part Number</i>	<i>Qty.</i>	<i>Description</i>
1	1-633131	1	Yoke-Linkage, Brake	9	114-8629	1	Bolt-Shoulder
2	7-0030	1	Screw-Shoulder, HH	10	121-6240-03	1	Bar-Brake
3	27-7211	1	Screw-Shoulder	11	121-6242-03	1	Handle-Brake
4	28-0540	1	Bolt-Shoulder	12	121-6243	1	Rod-Threaded
5	62-9130	1	Grip-Handle	13	121-6245-03	1	Plate-Brake
6	67-1450	1	Spring-Idler	14	3219-3	3	Nut-Hex
7	104-8300	1	Nut-HF, NI	15	3296-47	2	Nut-Lock, NI
8	114-2975	1	Link-Mounting	16	32128-20	1	Nut-HF

Engine and Muffler Assembly

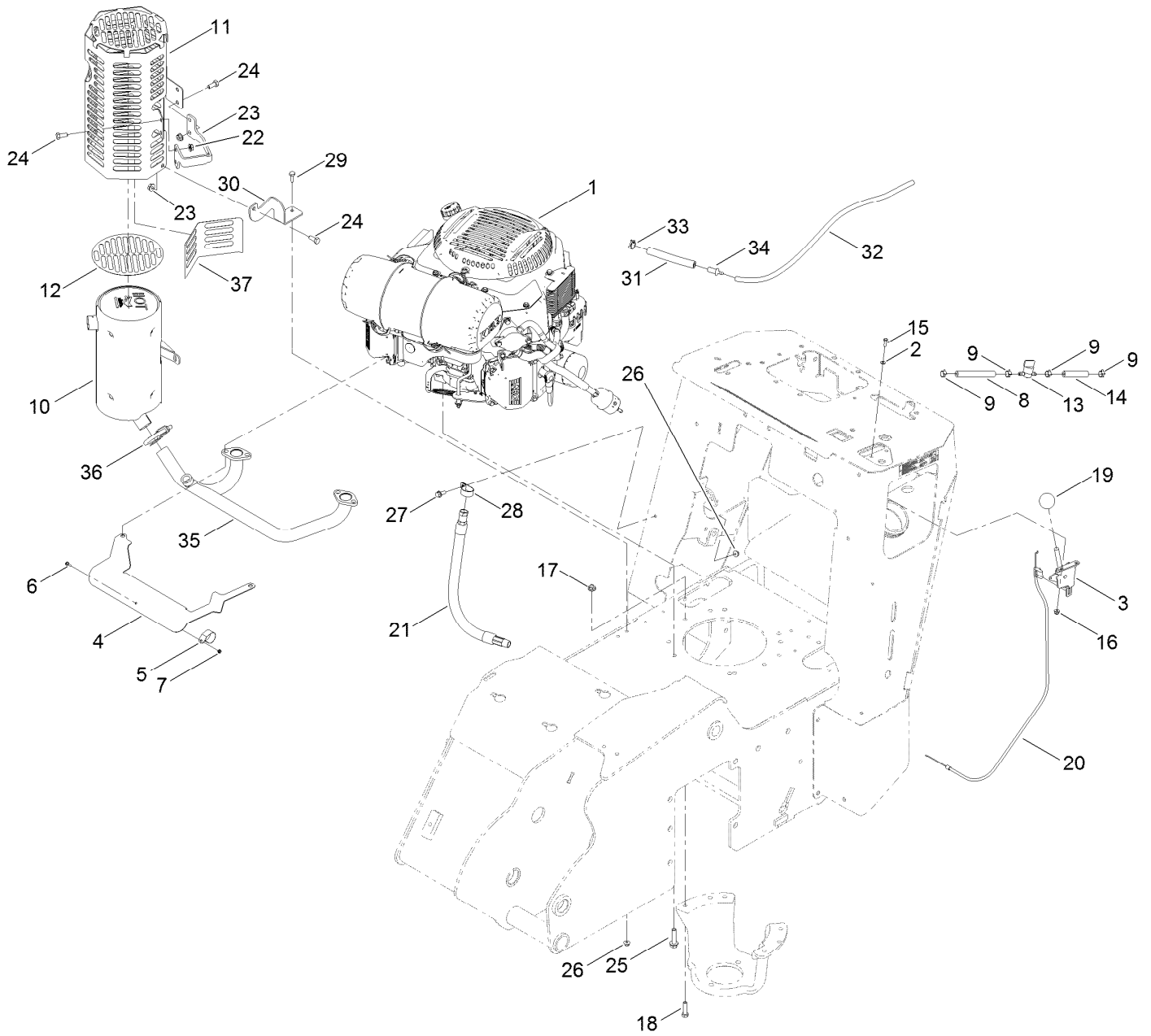

Engine and Muffler Assembly (continued)

<i>Ref.</i>	<i>Part Number</i>	<i>Qty.</i>	<i>Description</i>	<i>Ref.</i>	<i>Part Number</i>	<i>Qty.</i>	<i>Description</i>
1	138-3130	1	Engine-Kohler, Ps-Ecv749-3068 ▲	20	115-1211	1	Cable-Control
2	3256-21	2	Washer-Flat	21	116-5316	1	Oil Drain Hose ASM
3	110-5547	1	Lever-Control	21:2	353-508	1	Plug-HH ■●
4	137-7691	1	Shield-Heat	21:2:1	237-42	1	O-Ring ●
5	115-6488	1	Clamp	22	138-3101-03	1	Bracket-Muffler
6	115-6494	1	Screw-Pan	23	32128-26	5	Nut-Flange
7	115-6495	1	Nut-Hex	24	322-3	5	Screw-HH
8	109-0295	1	Hose-Fuel	25	32144-102	4	Screw-HWH
9	2412-98	4	Clamp-Hose	26	104-7201	3	Nut-HF
10	138-7138	1	Muffler-Kohler	27	3234-4	1	Screw-HHF
11	139-1310-03	1	Guard-Muffler	28	2412-106	1	Clamp-R
12	131-0604	1	Guard-Foil	29	321-4	2	Screw-HH
13	1-603770	1	Valve-Fuel	30	139-1335-03	1	Bracket-Guard, Muffler
14	109-0304	1	Hose-Fuel	31	138-3150	1	Hose-Vent
15	3290-134	2	Screw	32	138-3151	1	Hose-Vent
16	120-4578	2	Nut-HF	33	103-1988	1	Clamp-Hose
17	32128-20	3	Nut-HF	34	116-4630	1	Fitting-Orifice, Straight
18	322-6	3	Screw-HH	35	138-7139	1	Manifold-Kohler
19	233-42	1	Knob	36	2112-11	1	Clamp-Muffler
				37	139-1322	1	Guard-Foil

● Not illustrated

▲ Obtain parts from www.kohlerplus.com

■ Torque to 24-26 ft-lb

Hydraulic Assembly

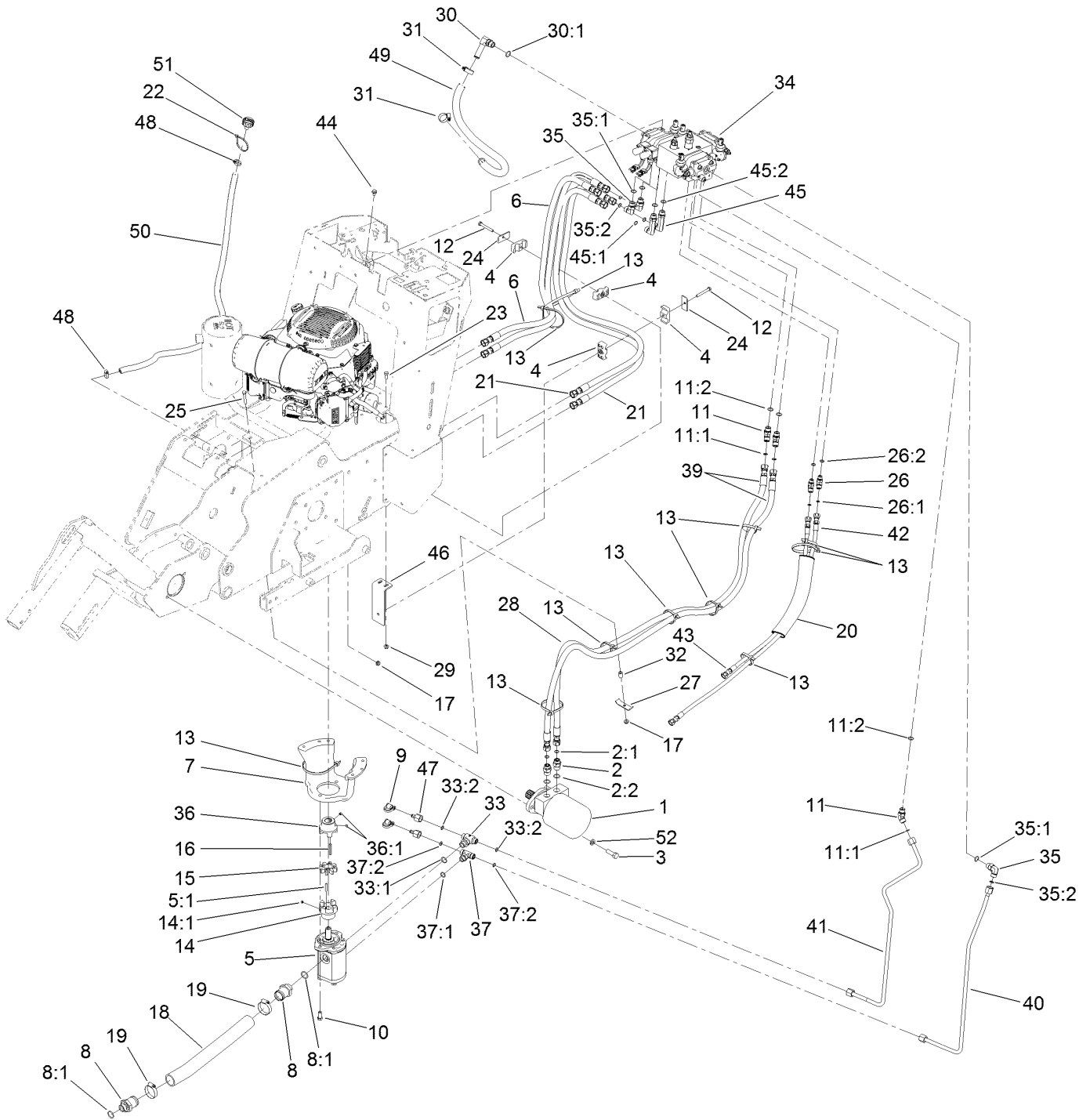

Hydraulic Assembly (continued)

<i>Ref.</i>	<i>Part Number</i>	<i>Qty.</i>	<i>Description</i>	<i>Ref.</i>	<i>Part Number</i>	<i>Qty.</i>	<i>Description</i>
1	117-6306	1	Hydraulic Motor ASM	27	100-4860	1	Bracket-Clamp
2	340-6	2	Fitting-Straight	28	99-5648	2	Sleeve-Protective
2:1	237-30	1	O-Ring	29	104-8300	2	Nut-HF, NI
2:2	237-80	1	O-Ring	30	87-8170	1	Fitting-90
3	325-6	2	Screw-HH	30:1	237-80	1	O-Ring
4	94-8105	6	Clamp-Tube	31	2412-129	2	Clamp-Hose
5	137-7630	1	Pump-HYD	32	93-5023	1	Spacer
5:1	27-8590	1	Key-Square	33	130-8775	1	Fitting-HYD
6	137-7682	2	Hydraulic Hose ASM	33:1	237-80	1	O-Ring
7	137-7634-03	1	Mount-Pump	33:2	237-30	2	O-Ring
8	138-7126	2	Fitting-STR	34	137-7646	1	Valve ASM
8:1	237-81	1	O-Ring	35	340-98	3	Fitting-Elbow, 90 DEG
9	354-79	2	Cap-Dust	35:1	237-79	1	O-Ring
10	324-4	2	Screw-HH	35:2	237-30	1	O-Ring
11	340-101	3	Fitting-HYD, 45 DEG	36	138-7100	1	Hub-Flex (1.125" Shaft)
11:1	237-30	1	O-Ring	36:1	105-4068	2	Screw-Set, HSH
11:2	237-79	1	O-Ring	37	340-157	1	Fitting-HYD, Tee
12	322-11	3	Screw-HH	37:1	237-79	1	O-Ring
13	3334-945	11	Tie-Cable	37:2	237-30	2	O-Ring
14	114-2933	1	Coupler-Flex	39	137-3730	2	Hydraulic Hose ASM
14:1	105-4068	1	Screw-Set, HSH	40	137-7698	1	HYD Tube ASM
15	93-8827	1	Coupler-Spider	41	137-3724	1	HYD Tube ASM
16	608006	1	Key-Square	42	137-3731	1	Hydraulic Hose ASM
17	32128-20	4	Nut-HF	43	137-3732	1	Hose-HYD
18	138-7128	1	Hose-Suction, HYD	44	68-9410	3	Screw-HHF
19	2412-130	2	Clamp-Hose	45	99-6160	2	Fitting-Elbow, 90 Long
20	115-4064	1	Sleeve-Protective	45:1	237-30	1	O-Ring
21	137-7680	2	Hydraulic Hose ASM	45:2	237-79	1	O-Ring
22	3290-379	1	Tie-Cable	46	137-3736-03	1	Bracket-Support, Hose
23	322-4	2	Screw-HH	47	100-5616	2	Fitting
24	69-9761	3	Plate-Cover	48	2412-36	2	Clamp-Hose
25	322-10	1	Screw-HH	49	137-3733	1	Hose-Cooler
26	340-87	2	Fitting-Elbow, 45 DEG	50	114-3042	1	Hose-Breather
26:1	237-22	1	O-Ring	51	68-6150	1	Breather
26:2	237-42	1	O-Ring	52	3253-7	2	Washer-Lock

Hydraulic Motor Assembly No. 117-6306

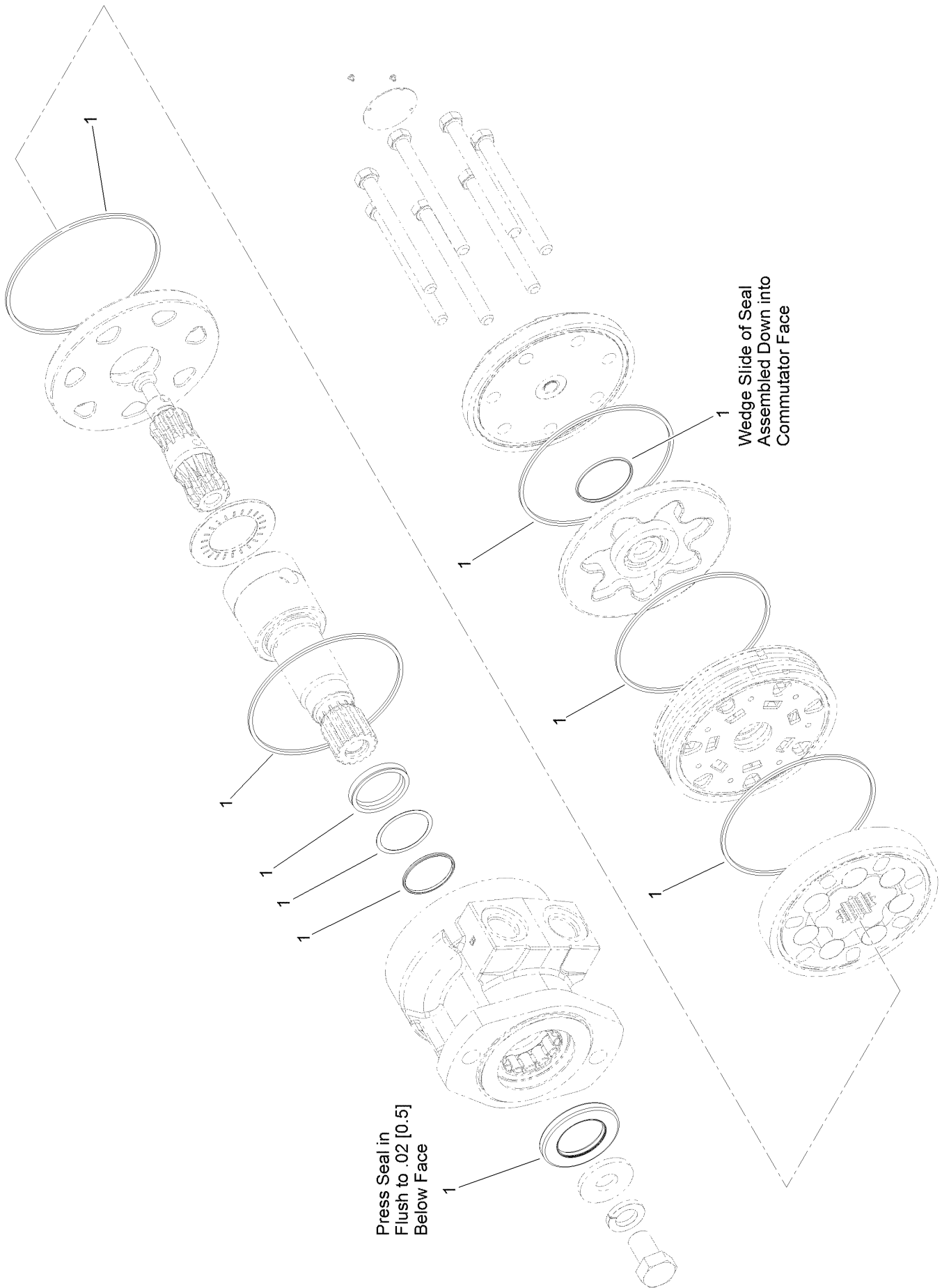

Hydraulic Motor Assembly No. 117-6306 (continued)

<i>Ref.</i>	<i>Part Number</i>	<i>Qty.</i>	<i>Description</i>
1	115-4061	1	Seal Kit

Valve Assembly No. 137-7646

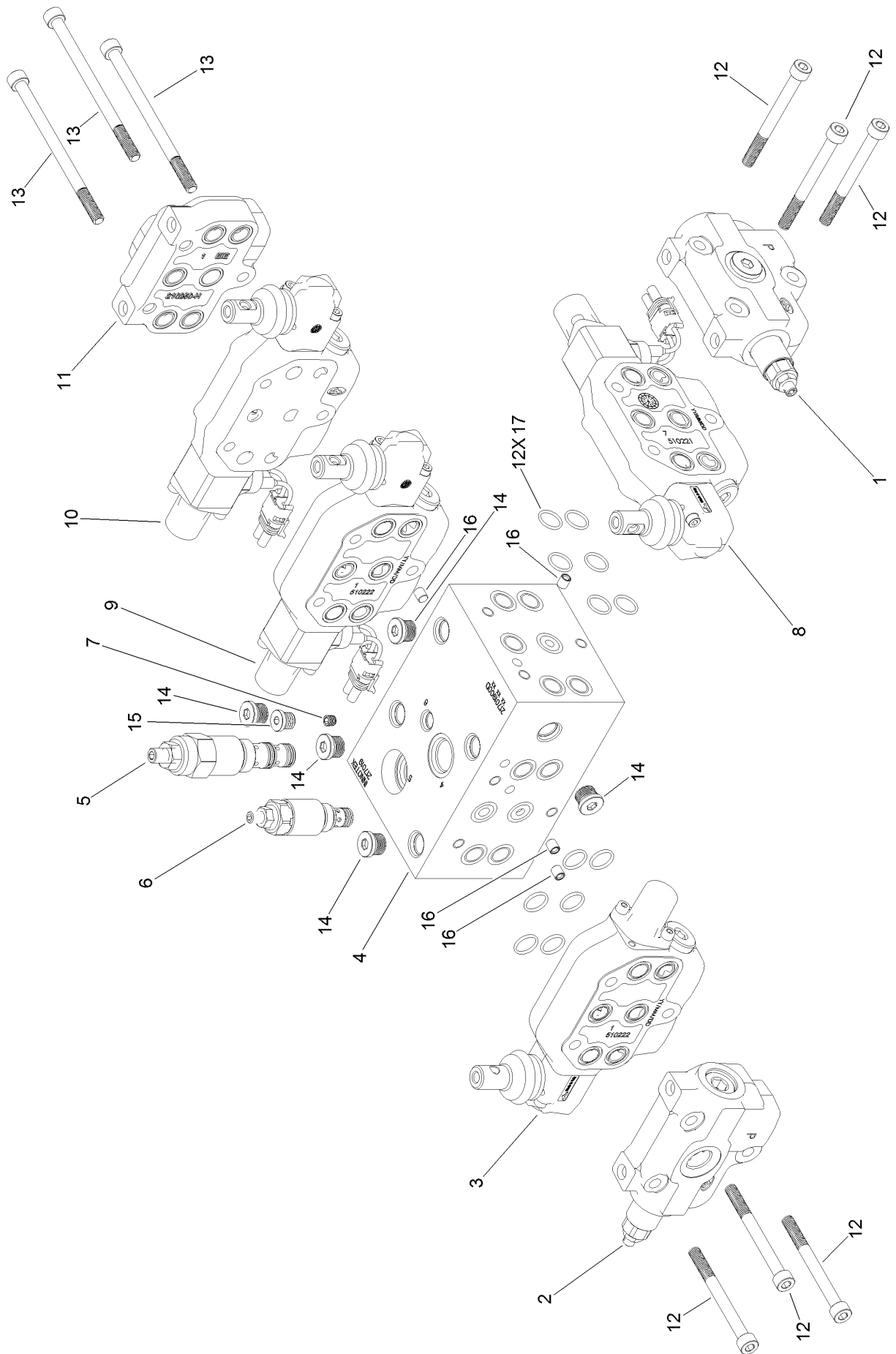

Valve Assembly No. 137-7646 (continued)

<i>Ref.</i>	<i>Part Number</i>	<i>Qty.</i>	<i>Description</i>	<i>Ref.</i>	<i>Part Number</i>	<i>Qty.</i>	<i>Description</i>
1	139-1337	1	Section-Inlet	10	139-1346	1	Section-Valve, Parallel
2	139-1338	1	Section-Inlet	11	139-1347	1	Section-Outlet
3	139-1339	1	Section-Valve, Series	12	139-1348	6	Screw-HSH
4	139-1340	1	Block-Manifold	13	139-1349	3	Screw-HSH
5	139-1341	1	Valve-Directional, Unloading	14	131-3807	5	Plug
6	139-1342	1	Valve-Relief	15	131-3806	1	Plug
7	139-1343	1	Plug-Orifice	16	140-1100	4	Plug-Expansion
8	139-1344	1	Section-Valve, Parallel	17	140-1101	12	O-Ring
9	139-1345	1	Section-Valve, Series				

Valve Inlet Section Assembly No. 139-1337

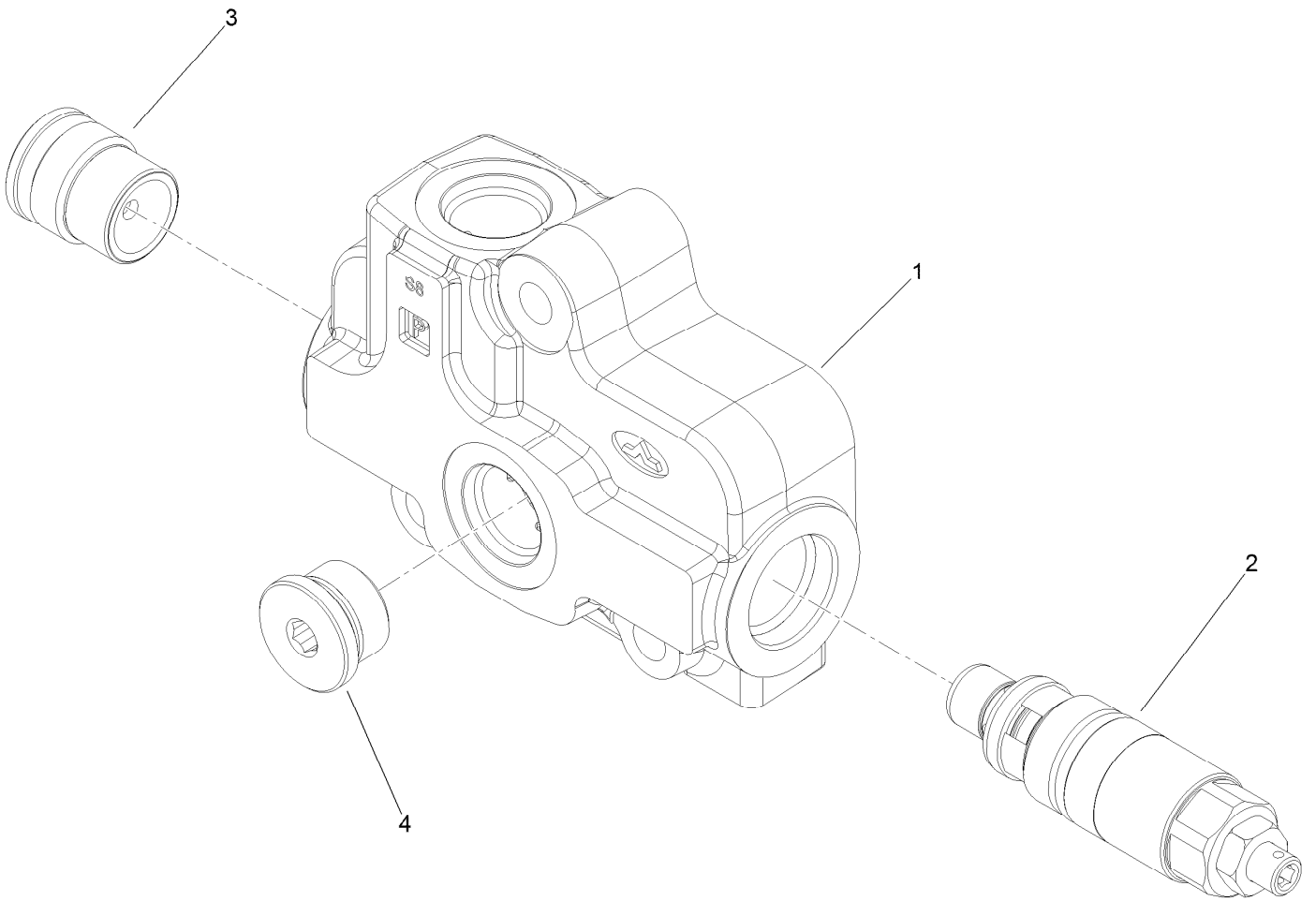

Valve Inlet Section Assembly No. 139-1337 (continued)

<i>Ref.</i>	<i>Part Number</i>	<i>Qty.</i>	<i>Description</i>
1	140-1102	1	Inlet
2	132-6039	1	Valve-Relief

<i>Ref.</i>	<i>Part Number</i>	<i>Qty.</i>	<i>Description</i>
3	140-1103	1	Plug
4	140-1104	1	Plug

Valve Inlet Section Assembly No. 139-1338

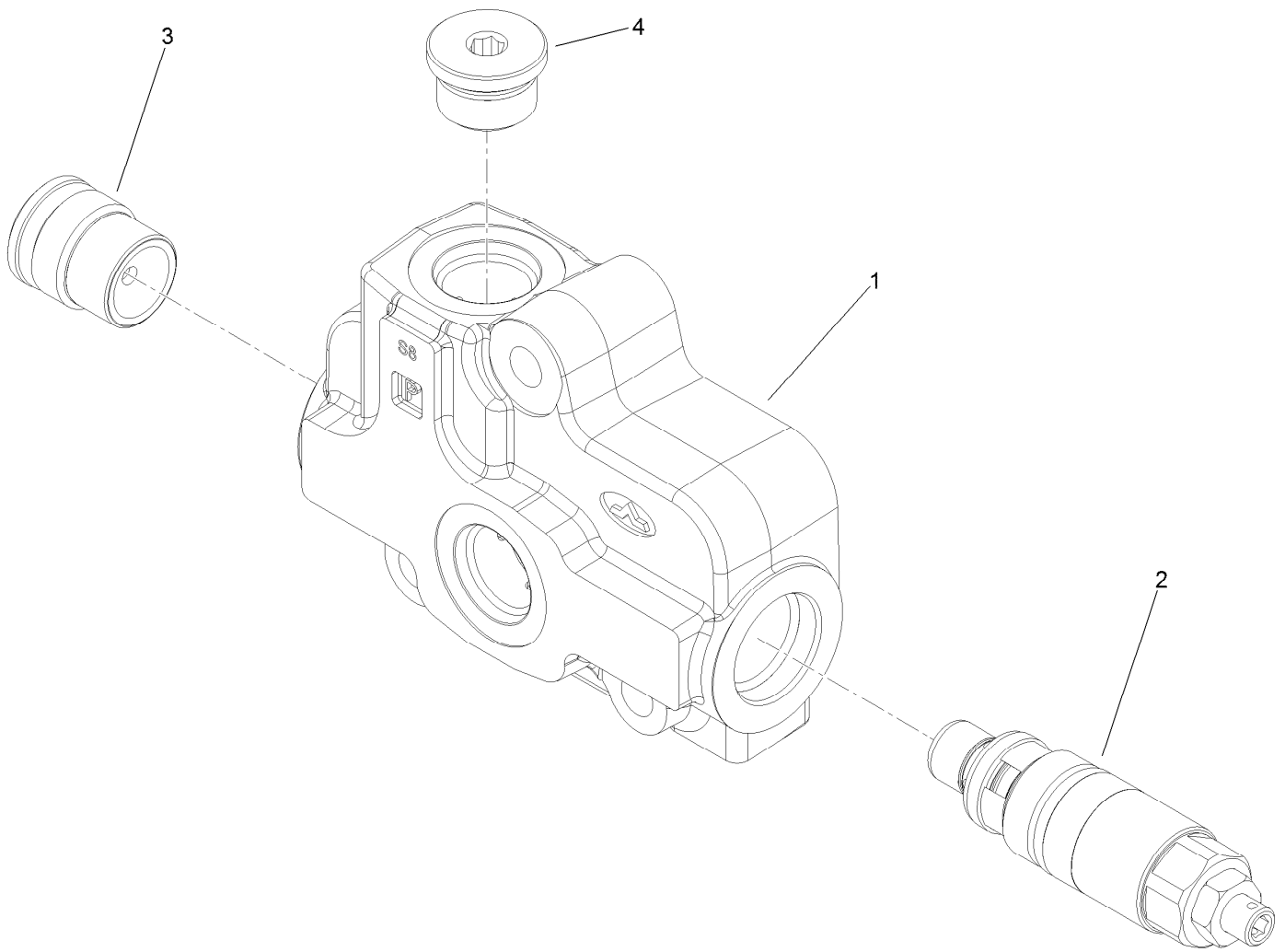

Valve Inlet Section Assembly No. 139-1338 (continued)

<i>Ref.</i>	<i>Part Number</i>	<i>Qty.</i>	<i>Description</i>
1	140-1102	1	Inlet
2	132-6039	1	Valve-Relief

<i>Ref.</i>	<i>Part Number</i>	<i>Qty.</i>	<i>Description</i>
3	140-1103	1	Plug
4	140-1104	1	Plug

Series Valve Section Assembly No. 139-1339

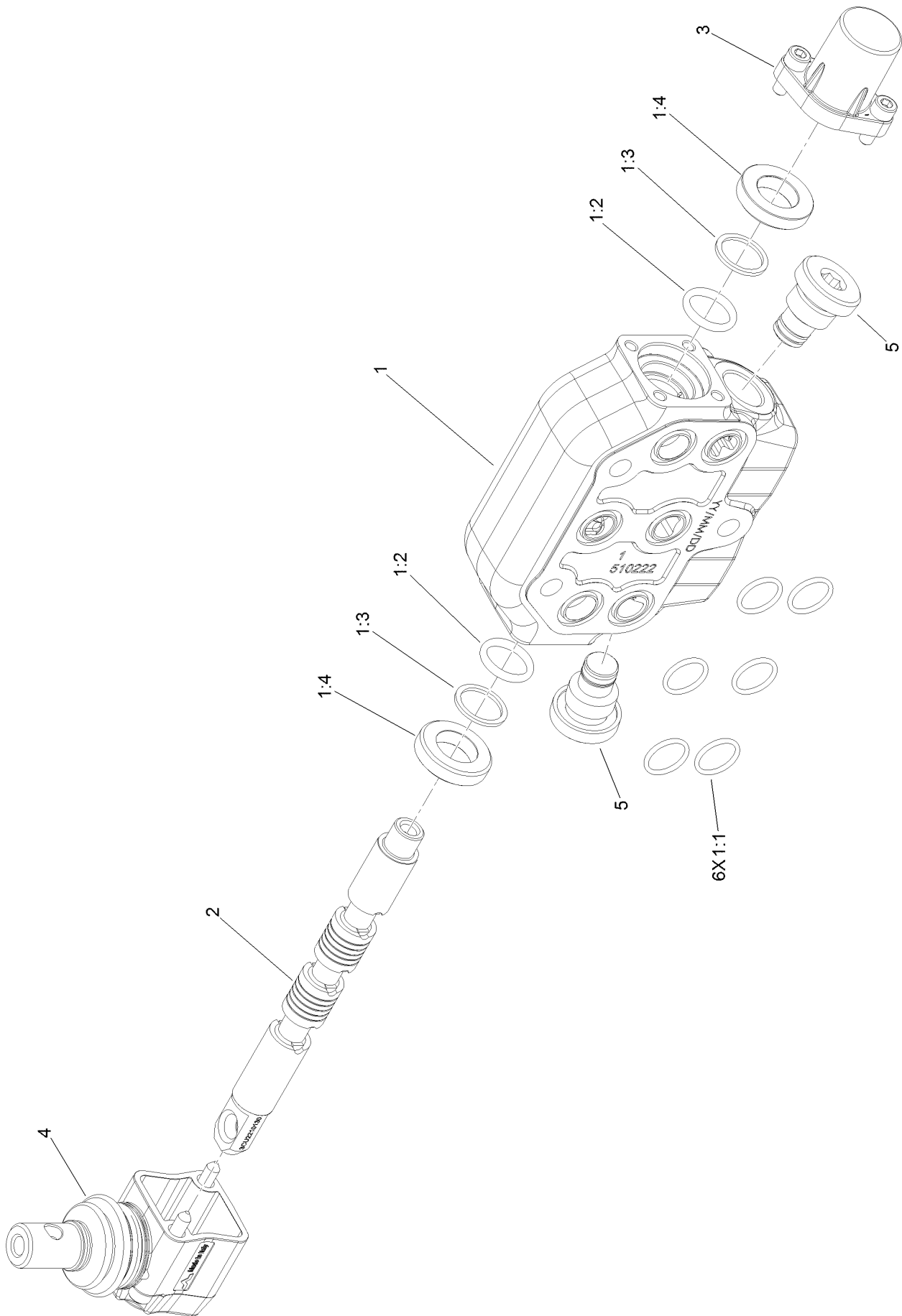

Series Valve Section Assembly No. 139-1339 (continued)

<i>Ref.</i>	<i>Part Number</i>	<i>Qty.</i>	<i>Description</i>	<i>Ref.</i>	<i>Part Number</i>	<i>Qty.</i>	<i>Description</i>
1	140-1109	1	Section-Working	2	140-1105	1	Valve-Spool
1:1	140-1114	6	O-Ring	3	140-1110	1	Kit-Control
1:2	106-7719	2	Seal-Valve	4	140-1107	1	Lever-Valve
1:3	140-1116	2	Seal-Valve	5	140-1108	2	Plug
1:4	140-1117	2	Seal-Valve				

Parallel Valve Section Assembly No. 139-1344

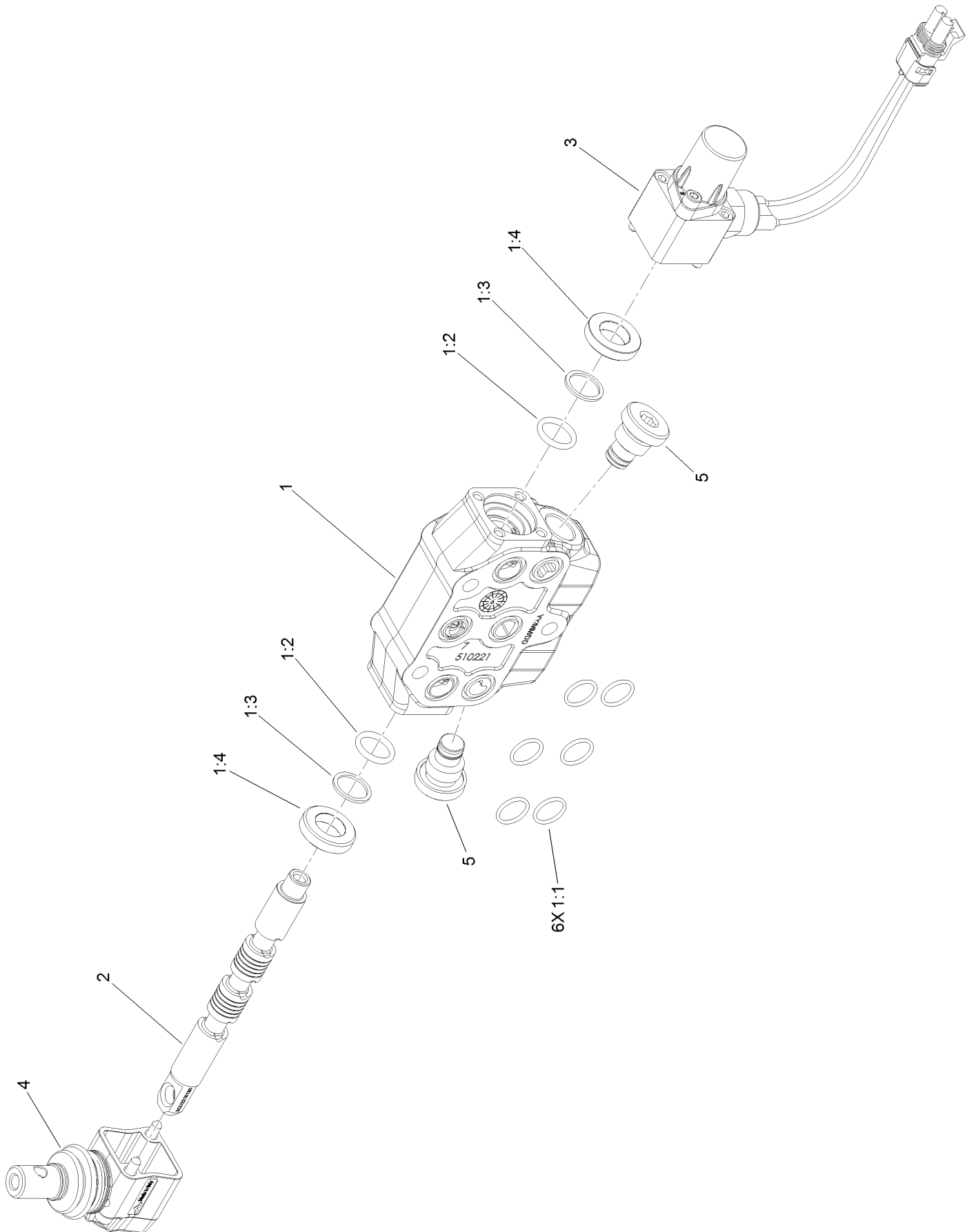

Parallel Valve Section Assembly No. 139-1344 (continued)

<i>Ref.</i>	<i>Part Number</i>	<i>Qty.</i>	<i>Description</i>	<i>Ref.</i>	<i>Part Number</i>	<i>Qty.</i>	<i>Description</i>
1	140-1115	1	Section-Working	2	140-1105	1	Valve-Spool
1:1	140-1114	6	O-Ring	3	140-1106	1	Kit-Control
1:2	106-7719	2	Seal-Valve	4	140-1107	1	Lever-Valve
1:3	140-1116	2	Seal-Valve	5	140-1108	2	Plug
1:4	140-1117	2	Seal-Valve				

Series Valve Section Assembly No. 139-1345

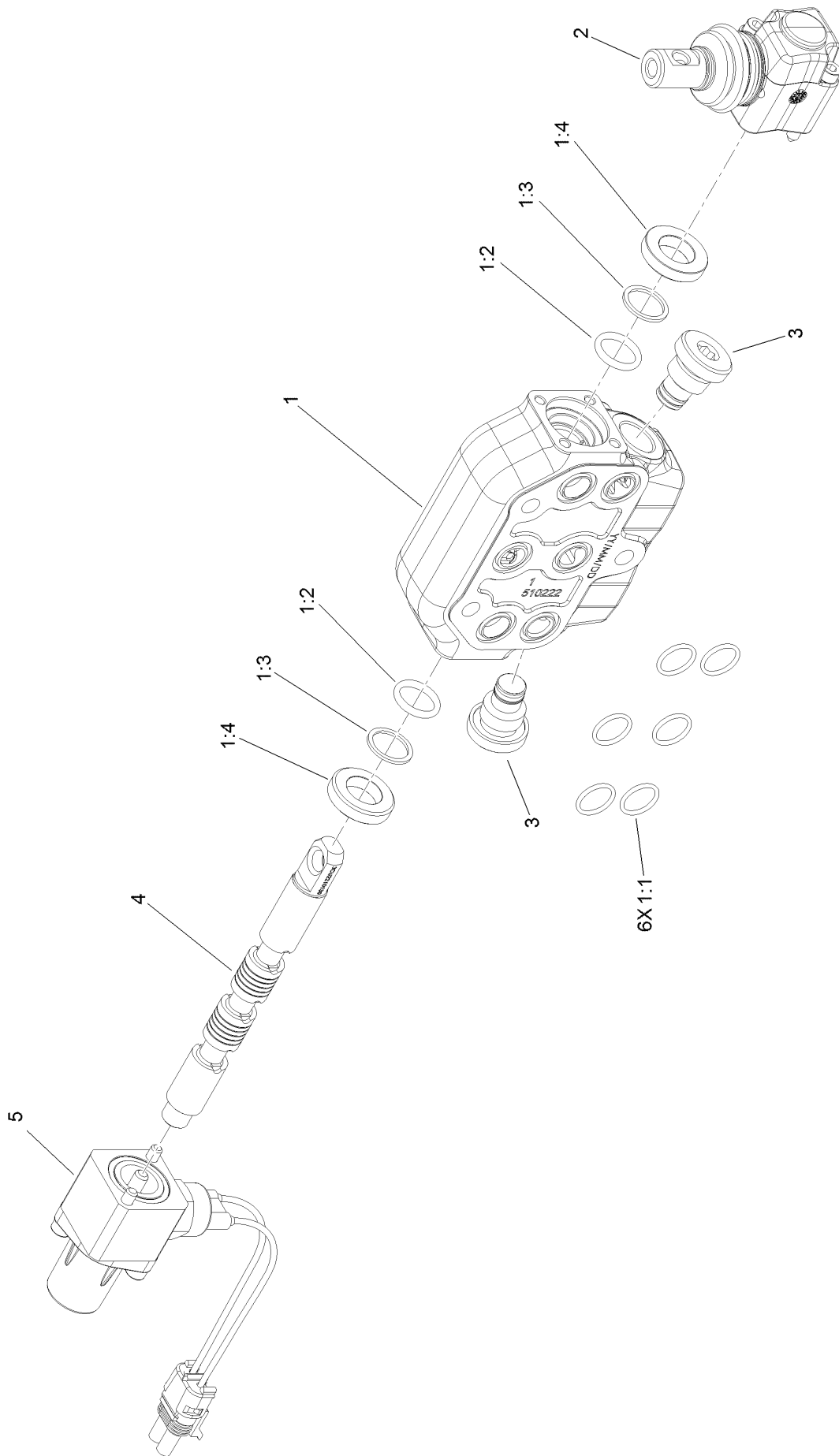

Series Valve Section Assembly No. 139-1345 (continued)

<i>Ref.</i>	<i>Part Number</i>	<i>Qty.</i>	<i>Description</i>	<i>Ref.</i>	<i>Part Number</i>	<i>Qty.</i>	<i>Description</i>
1	140-1118	1	Section-Working	2	140-1107	1	Lever-Valve
1:1	140-1114	6	O-Ring	3	140-1108	2	Plug
1:2	106-7719	2	Seal-Valve	4	140-1105	1	Valve-Spool
1:3	140-1116	2	Seal-Valve	5	140-1106	1	Kit-Control
1:4	140-1117	2	Seal-Valve				

Parallel Valve Section Assembly No. 139-1346

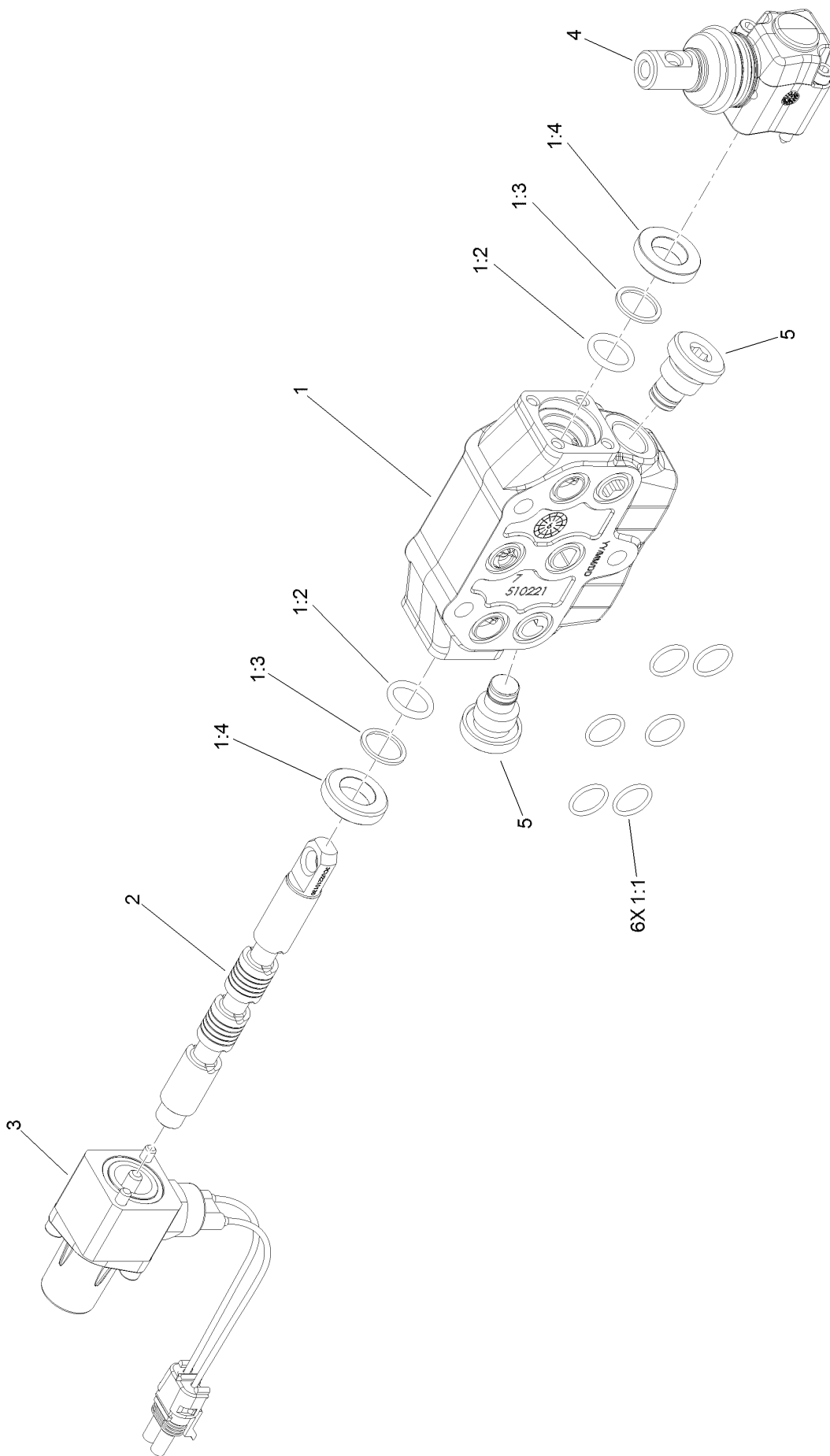

Parallel Valve Section Assembly No. 139-1346 (continued)

<i>Ref.</i>	<i>Part Number</i>	<i>Qty.</i>	<i>Description</i>	<i>Ref.</i>	<i>Part Number</i>	<i>Qty.</i>	<i>Description</i>
1	140-1115	1	Section-Working	2	140-1105	1	Valve-Spool
1:1	140-1114	6	O-Ring	3	140-1106	1	Kit-Control
1:2	106-7719	2	Seal-Valve	4	140-1107	1	Lever-Valve
1:3	140-1116	2	Seal-Valve	5	140-1108	2	Plug
1:4	140-1117	2	Seal-Valve				

Outlet Section Assembly No. 139-1347

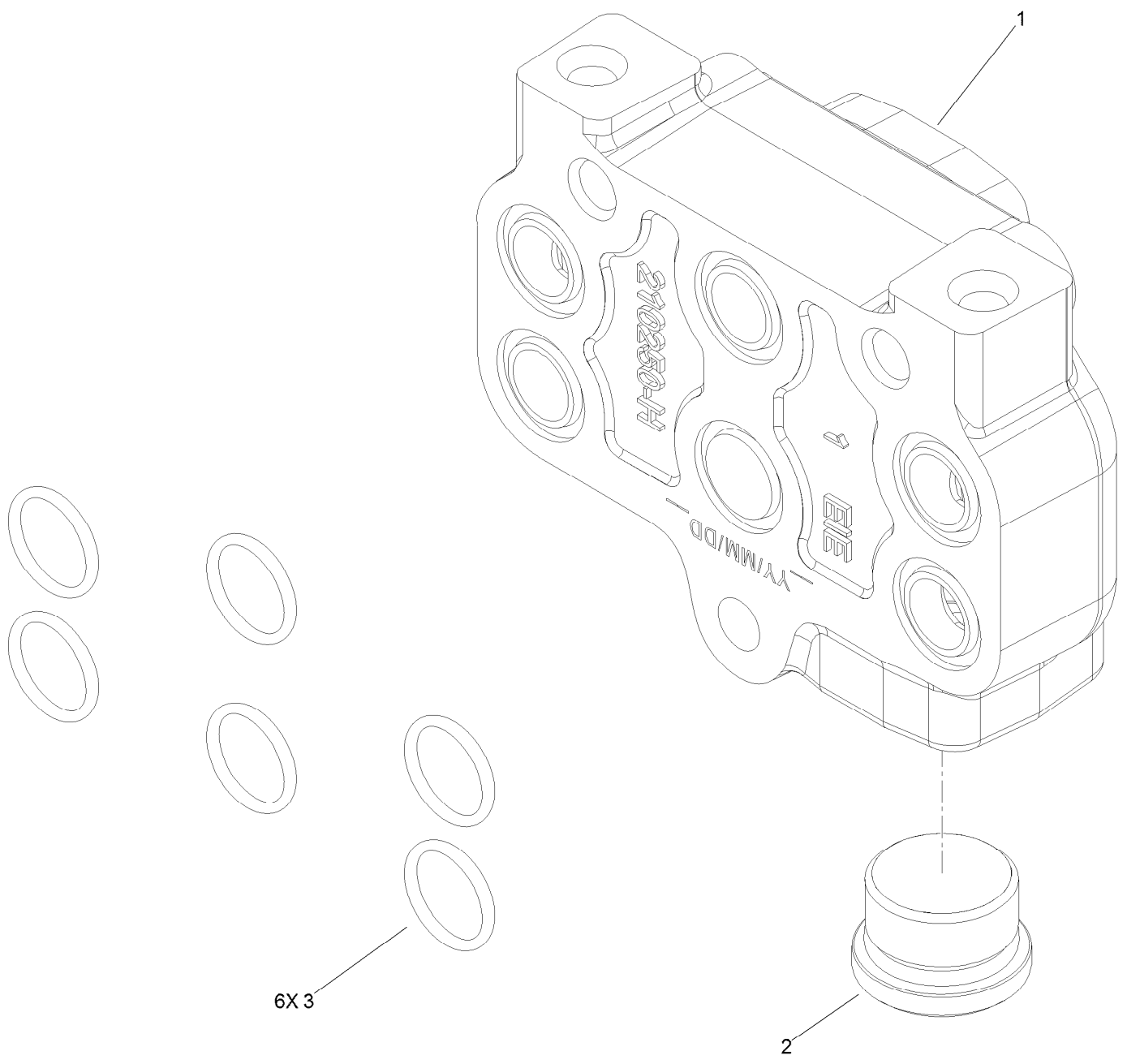

Outlet Section Assembly No. 139-1347 (continued)

<i>Ref.</i>	<i>Part Number</i>	<i>Qty.</i>	<i>Description</i>
1	140-1112	1	Cover-Outlet
2	140-1111	1	Plug
3	140-1114	6	O-Ring

Oil Cooler Assembly

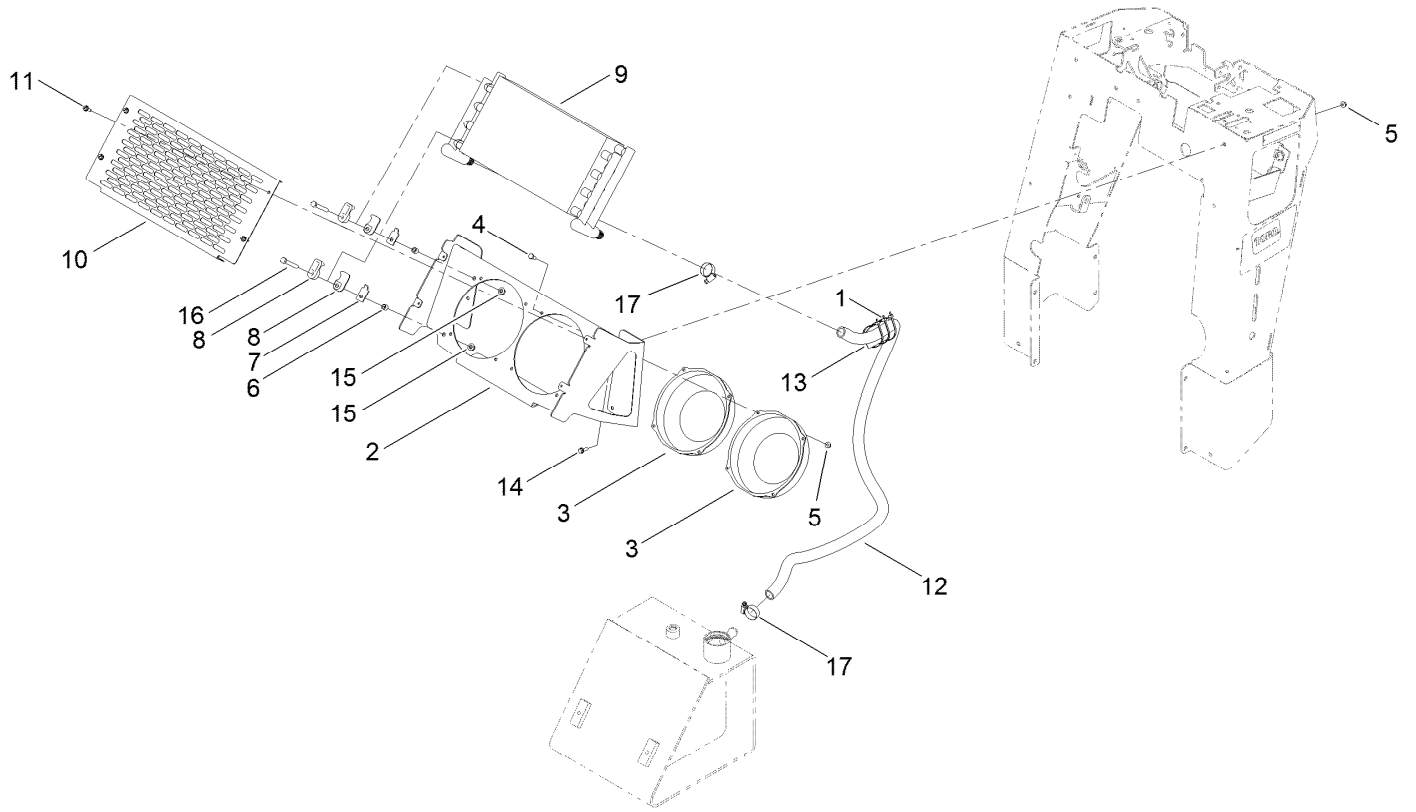

Oil Cooler Assembly (continued)

<i>Ref.</i>	<i>Part Number</i>	<i>Qty.</i>	<i>Description</i>	<i>Ref.</i>	<i>Part Number</i>	<i>Qty.</i>	<i>Description</i>
1	3290-379	3	Tie-Cable	10	119-4633-01	1	Cover-Cooler
2	115-9240-01	1	Mount-Cooler	11	32104-95	4	Screw-HWH
3	120-7390	2	Fan	12	138-3131	1	Hose-Return
4	321-3	8	Screw-HH	13	AU112950	1	Protector-Hose
5	104-7201	12	Nut-HF	14	115-5103	4	Screw-HHF
6	105-5723	4	Spacer-Tube	15	104-8300	4	Nut-HF, NI
7	131-0642	4	Plate-Support, Clamp	16	322-11	4	Screw-HH
8	131-0733	8	Clamp	17	2412-129	2	Clamp-Hose
9	117-6320	1	Cooler-Oil				

Trencher Head and Lift Assembly

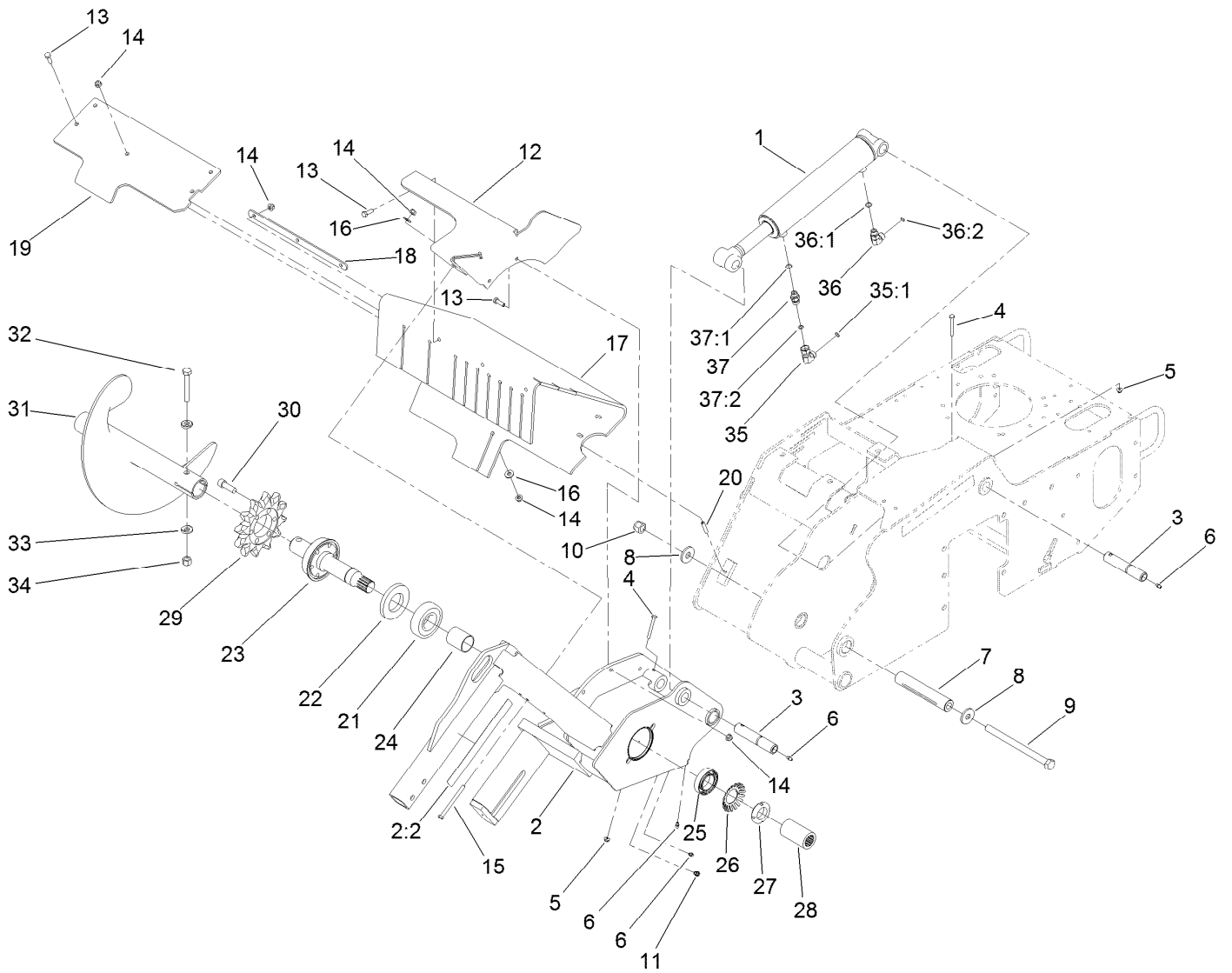

Trencher Head and Lift Assembly (continued)

<i>Ref.</i>	<i>Part Number</i>	<i>Qty.</i>	<i>Description</i>	<i>Ref.</i>	<i>Part Number</i>	<i>Qty.</i>	<i>Description</i>
1	137-3827	1	Hydraulic Cylinder ASM	22	114-2955	1	Seal-Grease
2	117-6423	1	Trencher Head ASM	23	117-6308	1	Shaft-Trencher
2:2	99-9952	2	Decal-Danger	24	112-4979	1	Spacer
3	120-7352	2	Pin-Pivot	25	111199	1	Bearing-Ball
4	321-18	2	Screw-HH	26	114-2956	1	Lockwasher-Bearing
5	104-7201	2	Nut-HF	27	88-1450	1	Locknut-Bearing
6	302-5	4	Fitting-Grease	28	117-6315	1	Collar-Splined
7	121-4571	1	Spacer-Pivot	29	104-1964	1	Sprocket-Trencher
8	104-9216	2	Washer-Hardened	30	3274-4	6	Screw-HSH
9	117-6327	1	Bolt-HH	31	137-3737-03	1	Auger-Trencher
10	3296-53	1	Nut-Lock, NI	32	325-13	1	Screw-HH
11	302-34	1	Fitting-Lube	33	117-3479	2	Washer-Saddle
12	115-1279-03	1	Bracket-Shield	34	3296-23	1	Nut-Lock, NI
13	322-5	8	Screw-HH	35	340-159	1	Elbow-90
14	104-8300	11	Nut-HF, NI	35:1	237-22	2	O-Ring
15	322-23	1	Screw-HH	36	340-77	1	Fitting-Elbow, 90 DEG
16	3256-3	4	Washer-Flat	36:1	237-22	1	O-Ring
17	117-6317	1	Shield-Dirt	36:2	237-42	1	O-Ring
18	115-4001-03	1	Plate-Strap, Shield	37	115-4081	1	Valve-Check
19	117-6316-03	1	Clamp-Bar	37:1	237-42	1	O-Ring
20	115-4049	2	Screw-HSH	37:2	237-22	1	O-Ring
21	106-8871	1	Bearing-Ball				

Hydraulic Cylinder Assembly No. 137-3827

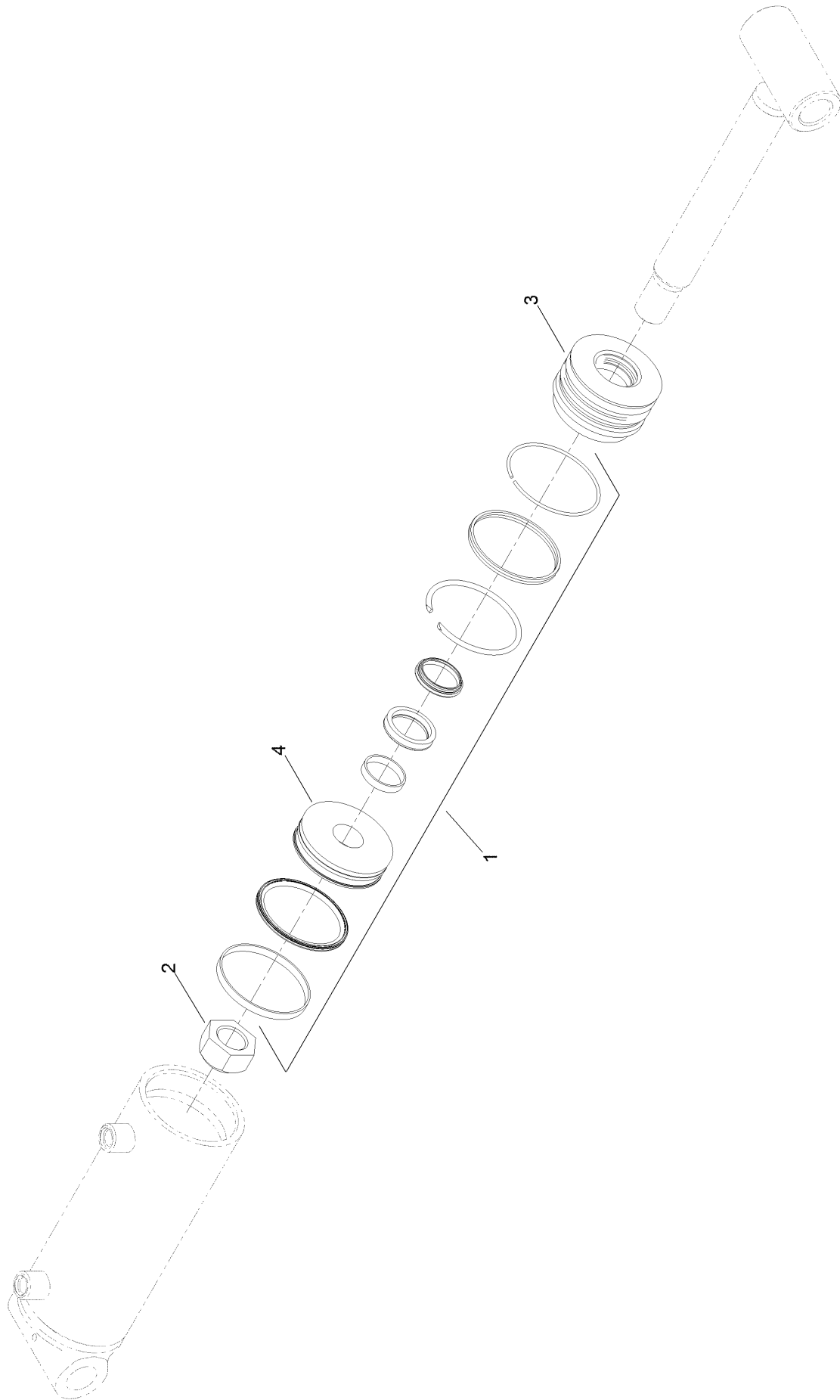

Hydraulic Cylinder Assembly No. 137-3827 (continued)

<i>Ref.</i>	<i>Part Number</i>	<i>Qty.</i>	<i>Description</i>
1	138-7140	1	Seal Kit
2	138-7141	1	Nut-Hex

<i>Ref.</i>	<i>Part Number</i>	<i>Qty.</i>	<i>Description</i>
3	138-7142	1	Head-Cylinder
4	138-7143	1	Piston

Control Assembly

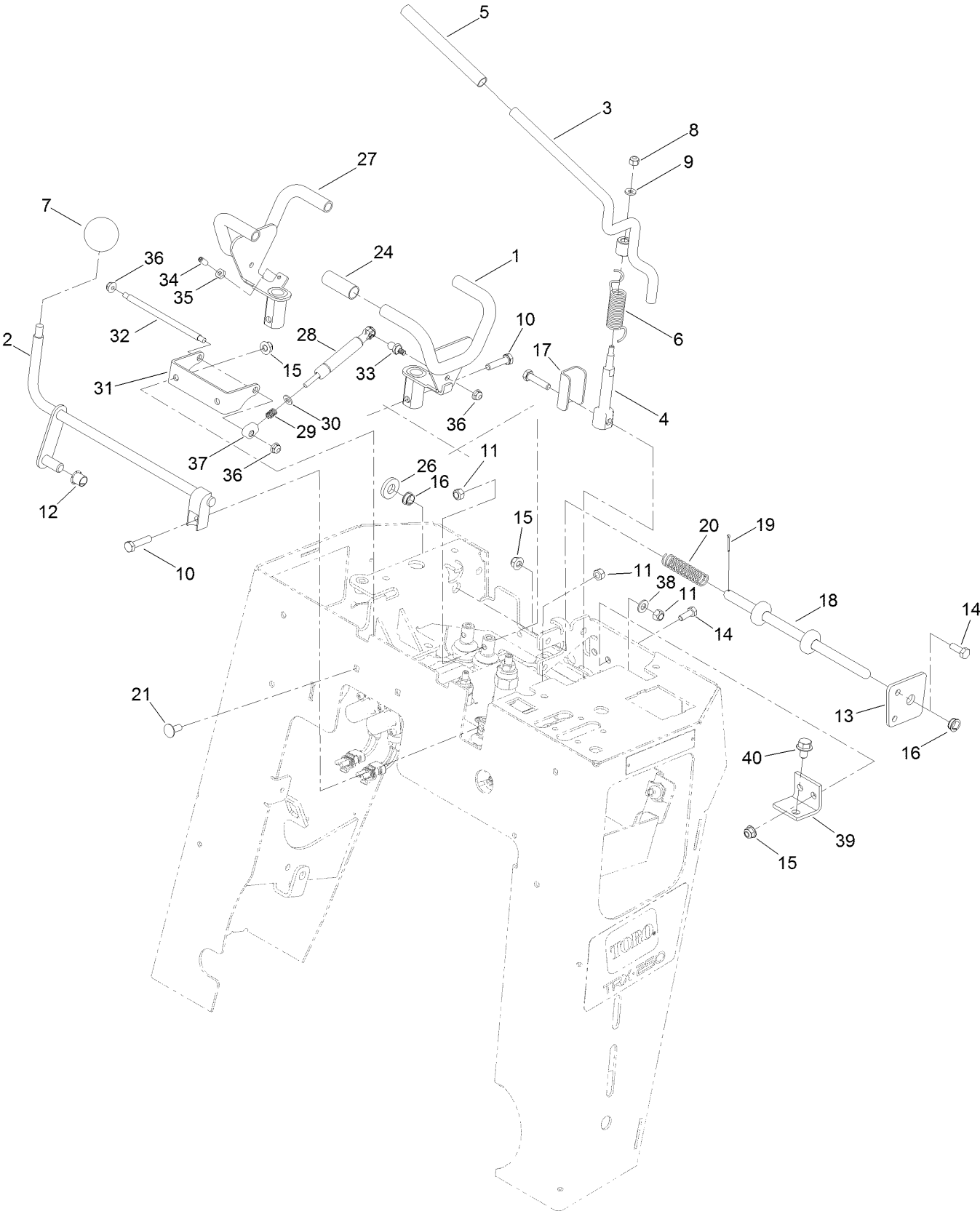

Control Assembly (continued)

<i>Ref.</i>	<i>Part Number</i>	<i>Qty.</i>	<i>Description</i>	<i>Ref.</i>	<i>Part Number</i>	<i>Qty.</i>	<i>Description</i>
1	140-5764-03	1	Handle-Traction, LH	20	95-4256	1	Spring-Compression
2	139-1306	1	Lever-Lift	21	3230-23	2	Bolt-CARR
3	137-7651	1	Lever-Auxiliary	24	139-1307	4	Grip
4	137-7649	1	Lever-Drive, Chain	26	107-3395	1	Washer-Hardened
5	138-3168	1	Grip	27	140-5765-03	1	Handle-Traction, RH
6	112-2738	1	Spring-Torsion	28	139-1314	2	Damper
7	233-21	1	Knob	29	139-1321	2	Spring-Compression
8	3296-42	1	Nut-Lock, NI	30	139-1323	2	Washer-Spcl
9	3256-16	1	Washer-Flat	31	139-1299-03	1	Bracket-Damper
10	33114-035	4	Screw-HH	32	139-1316	1	Rod-Damper
11	33024-00	4	Nut-Lock, NI	33	139-1315	2	Stud-Ball
12	256-257	1	Bushing-Nyliner	34	3245-3	2	Screw-Set, Hs
13	138-3123-03	1	Plate-Bushing	35	3218-1	2	Nut-Jam
14	322-4	4	Screw-HH	36	104-7201	4	Nut-HF
15	104-8300	6	Nut-HF, NI	37	140-1122	2	Fitting-Clevis
16	116-1393	2	Bushing	38	3256-23	1	Washer-Plain
17	138-3124	1	Bracket-Lever	39	140-5767	1	Bracket-Valve
18	138-7163	1	Rod-Lockout	40	68-9410	1	Screw-HHF
19	3272-4	1	Pin-Cotter				

Electrical Assembly

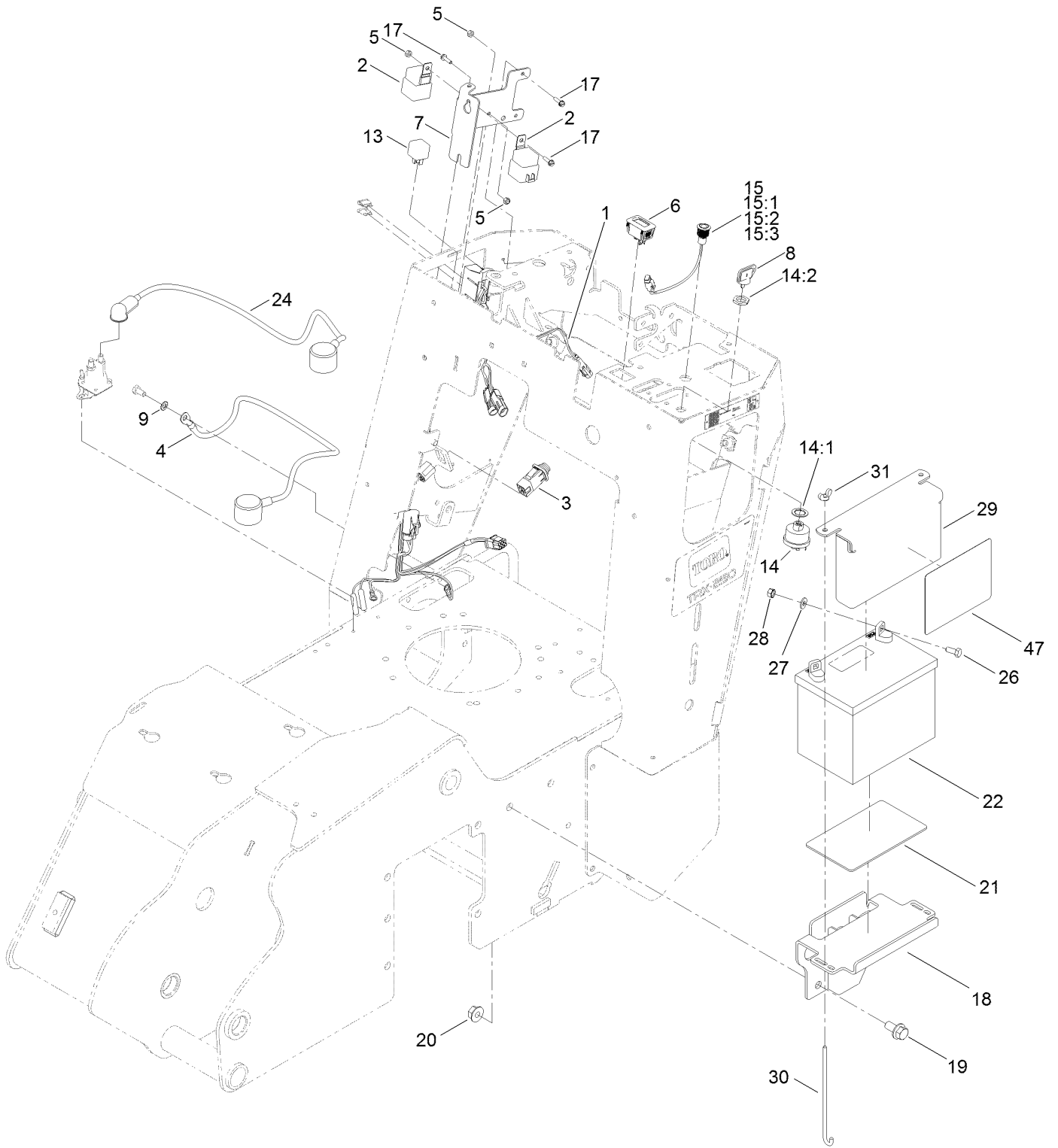

Electrical Assembly (continued)

<i>Ref.</i>	<i>Part Number</i>	<i>Qty.</i>	<i>Description</i>	<i>Ref.</i>	<i>Part Number</i>	<i>Qty.</i>	<i>Description</i>
1	137-7624	1	Harness-Wire	15:2	122-0633	1	Washer-Locking
2	99-7430	2	Relay-Mini	15:3	122-0632	1	Nut-Fixing
3	100-1268	1	Switch-Plunger	17	32105-13	4	Screw-HWH
4	138-3133	1	Cable-Battery, Negative	18	138-3114-03	1	Tray-Battery
5	3296-2	4	Nut-Lock, NI	19	3234-6	2	Screw-HHF
6	120-2244	1	Hourmeter	20	32128-49	2	Nut-HHF
7	138-3104-03	1	Bracket-Electrical	21	62-4300	1	Pad-Skid, Anti
8	63-8360	1	Key-Ignition	22	104-8162	1	Battery
9	3255-7	1	Washer-Lock/EXT	24	138-3134	1	Cable-Battery, Positive
13	98-7249	1	Relay	26	322-3	2	Screw-HH
14	88-9830	1	Key Switch ASM	27	3256-2	2	Washer-Flat
14:1	3254-5	1	Washer-Lock	28	32149-1	2	Nut-Keps
14:2	218-461	1	Nut-HH	29	115-6621-03	1	Plate-Hold Down, Battery
15	122-0630	1	Red LED Indicator Lamp ASM	30	1-633651	2	Bolt-Holddown
15:1	122-0634	1	Gasket-LED	31	32103-22	2	Nut-Wing
				47	138-7155	1	Decal-Service

Wire Harness Assembly No. 137-7624

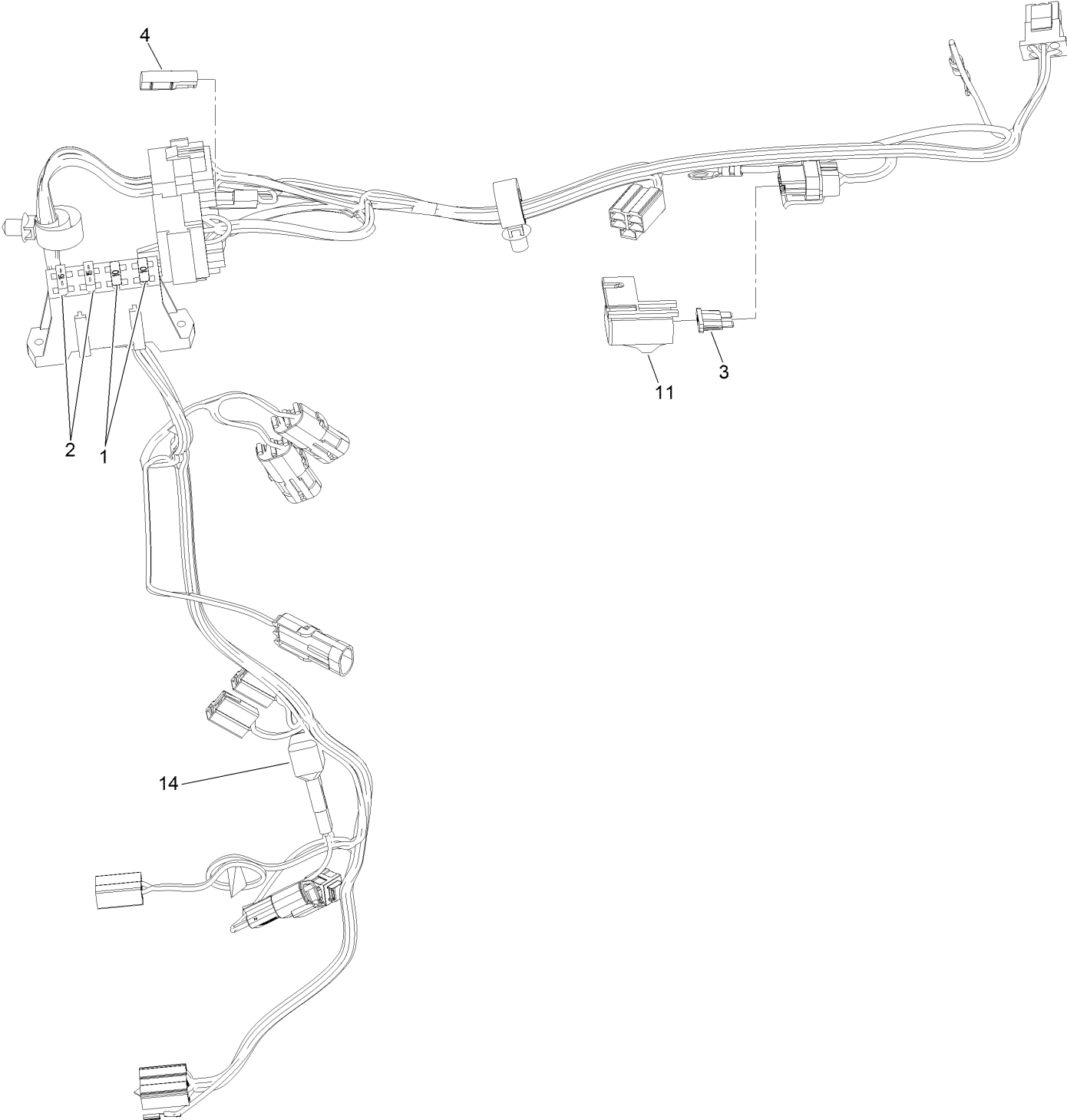

Wire Harness Assembly No. 137-7624 (continued)

<i>Ref.</i>	<i>Part Number</i>	<i>Qty.</i>	<i>Description</i>	<i>Ref.</i>	<i>Part Number</i>	<i>Qty.</i>	<i>Description</i>
1	218-578	2	Fuse-Blade, 10 Amp	4	116-0053	1	Cap-Plug
2	109355	2	Fuse-Blade, 15 Amp	11	32180-019	1	Cover-Fuse, Single
3	109103	1	Fuse-Blade, 30 Amp	14	121-8891	1	Resistor (1.6K Ohm)

Attachments and Accessories

For 22984 TRX-300 Trencher

Product Name	Model/Part
Crumber Kit	22477
24in Trencher Boom	22975
36in Trencher Boom	22976
48in Trencher Boom	22977
24in X 4in Soil Chain.....	22480
24in X 6in Soil Chain.....	22483
36in X 4in Soil Chain.....	22486
36in X 6in Soil Chain.....	22490
24in X 4in Combination Chain	22481
Spark Arrestor Screen	94-8157
24in X 6in Combination Chain	22484
36in X 4in Combination Chain	22487
36in X 6in Combination Chain	22491
24in X 4in Rock Tooth Chain.....	22482
24in X 6in Rock Tooth Chain.....	22485
36in X 4in Rock Tooth Chain.....	22488
36in X 6in Rock Tooth Chain.....	22489
48in x 4in Soil Chain	22492
48in x 4in Combination Chain	22493
48in x 6in Soil Chain	22494
48in x 6in Combination Chain	22495
24in X 4in Bullet Chain.....	22496
24in X 6in Bullet Chain.....	22497
36in X 4in Bullet Chain.....	22498
36in X 6in Bullet Chain.....	22499
Bore Drive Attachment.....	22978
Backfill Blade	22980
8in Chain Conversion Kit for 36in Soil Chain.....	117-3480

Notes:



Count on it.