



Count on it.

Parts Catalog

TRX-250

Trencher

Model No. 22983—Serial No. 407740000 and Up



Ordering Replacement Parts

To order replacement parts, please supply the part number, the quantity, and the description of each part desired.

Understanding Reference Numbers

Each identified part in an illustration has a reference number. The reference number for a part also appears in the parts list, along with other information about the part.

This catalog uses two special reference number formats, one to indicate parts in a service assembly and another to indicate the quantity of a given part in an illustration.

Service Assembly Reference Numbers

Parts in service assemblies have reference numbers in the form a:b. The a represents the reference number of the entire service assembly and the b represents a sequential number unique to each part within the service assembly.

For example, a wheel assembly might be identified by reference number 6, the tire by 6:1, the valve by 6:2, and the wheel by 6:3. When you order the assembly identified by reference number 6, you receive all parts identified by reference numbers 6:1, 6:2, and 6:3. However, you may also order any part individually. Reference numbers of this type appear in illustration and in parts lists.

Reference Numbers Indicating Quantity

In an illustration, if a reference number indicates more than one part, the reference number has the form nX y. The n represents the quantity of the part, the X is the multiplication symbol, and the y represents the reference number.

For example, in an illustration, the reference number 2X 37 means that two of the parts identified by reference number 37 are indicated.

Contents

Frame Assembly	4
Control Tower and Fuel Tank Assembly	6
Track Assembly	8
Brake Linkage Assembly	10
Engine, Muffler and Air Cleaner Assembly	12
Air Cleaner Assembly No. 93-2190	14
Hydraulic Assembly	16
Hydraulic Motor Assembly No. 117-6306	18
Valve Assembly No. 137-7646	20
Valve Inlet Section Assembly No. 139-1337	22
Valve Inlet Section Assembly No. 139-1338	24
Series Valve Section Assembly No. 139-1339	26
Parallel Valve Section Assembly No. 139-1344	28
Series Valve Section Assembly No. 139-1345	30
Parallel Valve Section Assembly No. 139-1346	32
Outlet Section Assembly No. 139-1347	34
Oil Cooler Assembly	36
Trencher Head and Lift Assembly	38
Hydraulic Cylinder Assembly No. 137-3827	40
Control Assembly	42
Electrical Assembly	44
Wire Harness Assembly No. 138-7153	46
Fuel System Assembly	48
Carburetor Assembly	50
Air Intake and Filtration Assembly	52
Ignition and Cooling Fan Assembly	54
Crankcase and Crankshaft Assembly	56
Governor Control Assembly	58
Piston and Cylinder Head Assembly	60
Blower Housing Assembly	62
Gasket and Seal Kit	64
Attachments and Accessories	66

Frame Assembly

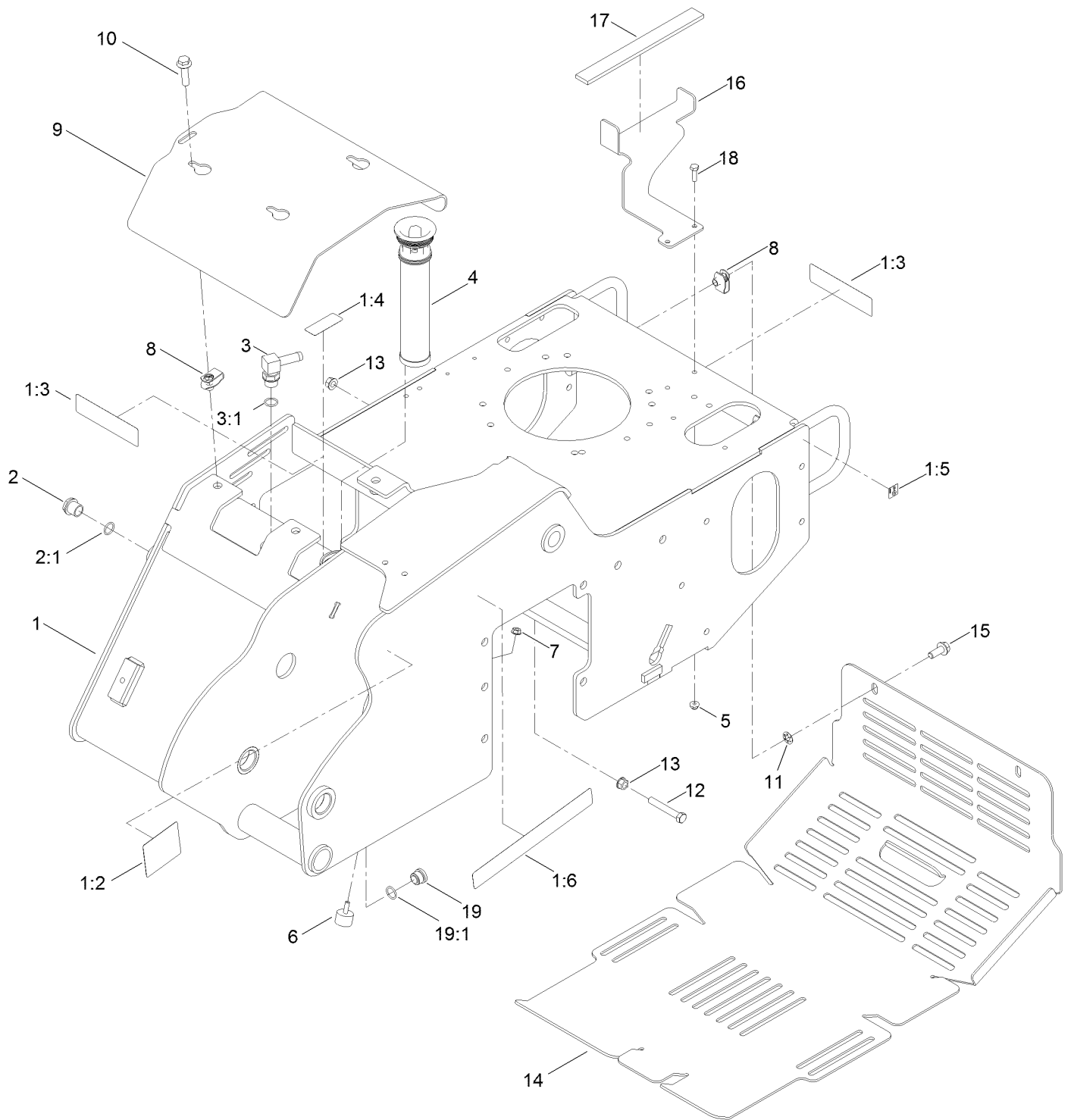

Frame Assembly (continued)

<i>Ref.</i>	<i>Part Number</i>	<i>Qty.</i>	<i>Description</i>	<i>Ref.</i>	<i>Part Number</i>	<i>Qty.</i>	<i>Description</i>
1	137-7628	1	Main Frame ASM	8	140-1146	5	Nut-Clip, U
1:2	100-4650	1	Decal-Warning	9	137-7623-03	1	Plate-Cover, Front
1:3	93-7814	2	Decal-Danger	10	33105-040	5	Screw-HHF
1:4	93-6686	1	Decal-Oil, HYD	11	140-1144	5	Nut-Push
1:5	93-9084	2	Decal-Point, Lift	12	323-12	1	Screw-HH
1:6	138-7103	1	Decal-Intellitrench	13	32128-40	2	Nut-Flange
2	114-3075	1	Sight Glass ASM	14	119-5106-01	1	Cover-Rear
2:1	237-79	1	O-Ring	15	108-1531	2	Screw-HHF
3	354-120	1	Fitting-Elbow, 90	16	119-5091-01	1	Bracket-Tank
3:1	237-79	1	O-Ring	17	117-6417	1	Pad-Foam
4	114-3039	1	Filter-Tank, In	18	321-5	2	Screw-HH
5	104-7201	2	Nut-HF	19	133-7659	1	Plug ASM
6	1-523420	1	Bumper	19:1	237-79	1	O-Ring
7	32128-33	1	Nut-HF				

Control Tower and Fuel Tank Assembly

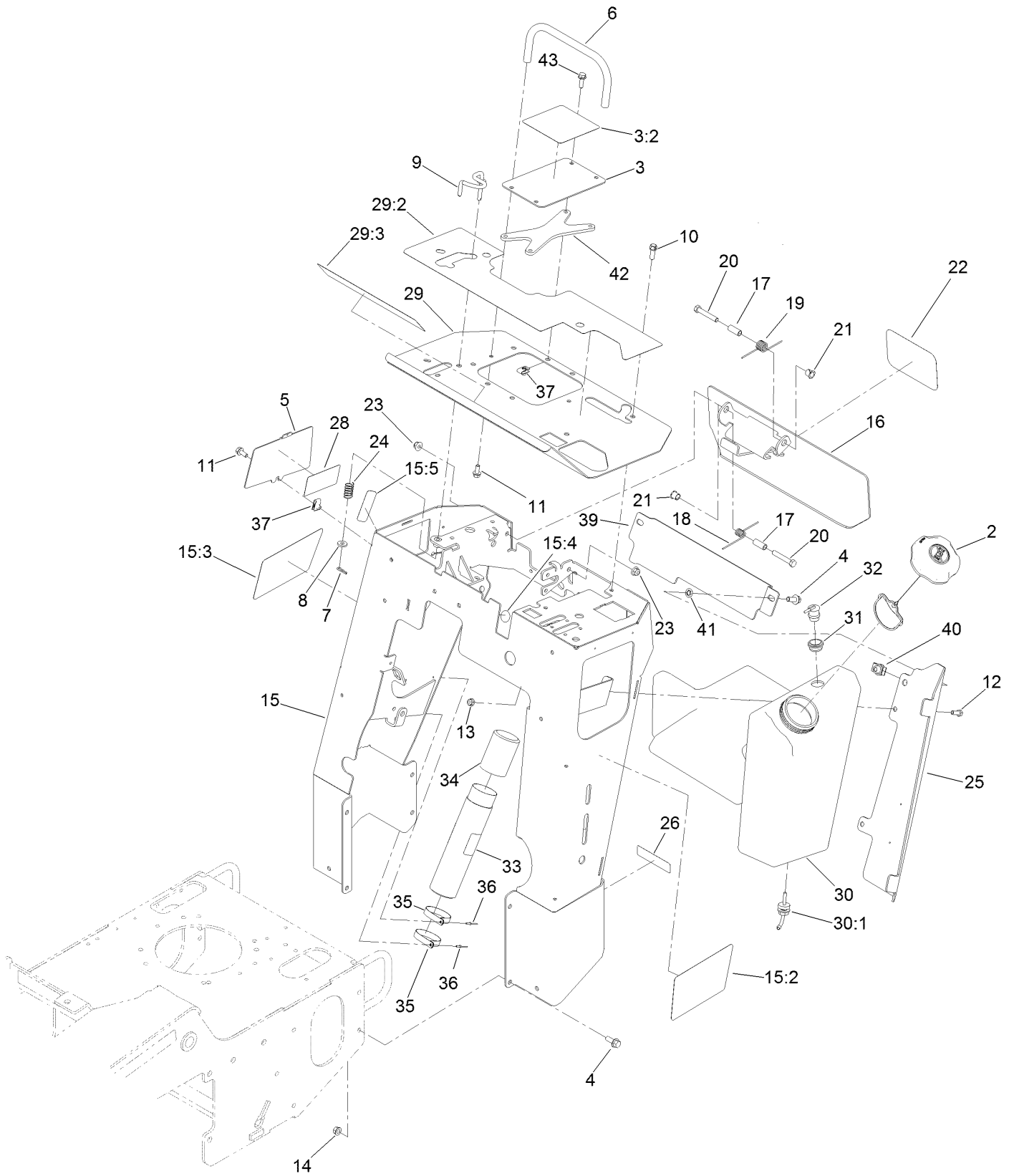

Control Tower and Fuel Tank Assembly (continued)

<i>Ref.</i>	<i>Part Number</i>	<i>Qty.</i>	<i>Description</i>	<i>Ref.</i>	<i>Part Number</i>	<i>Qty.</i>	<i>Description</i>
2	137-4119	1	Cap-Fuel, Ratcheting	21	256-257	2	Bushing-Nyliner
3	137-3795	1	Cover-Handle, Traction	22	105-1217	1	Decal
3:2	138-7107	1	Decal-Traction	23	104-8301	2	Nut-HF, NI
4	3234-11	10	Screw-HHF	24	85-6750	1	Spring-Control
5	137-7654-01	1	Plate-Cover, Access	25	119-5086-01	1	Bracket-Cover, Tank
6	137-7641	1	Bar-Reference	26	133-8062	1	Decal-Arrestor, Spark
7	3290-307	1	Pin-Cotter	28	138-7154	1	Decal-Fuse
8	88-7200	1	Washer-Flat	29	137-3797	1	Cover-Control
9	114-8727	1	Rod-Interlock	29:2	138-7105	1	Decal-Panel, Control
10	95-1726	4	Screw-Taptite	29:3	138-7104	1	Decal-Safety
11	3234-5	3	Screw-HHF	30	120-7359	1	Tank-Fuel
12	322-4	2	Screw-HH	30:1	103-2605	1	Fitting-Fuel, Bulkhead
13	104-8300	2	Nut-HF, NI	31	114-0284	1	Grommet
14	32128-40	8	Nut-Flange	32	119-3547	1	Valve-Vent, Fuel
15	138-3157	1	Control Tower ASM	33	104-7050	1	Tube-Manual
15:2	137-3837	1	Decal-Side, LH	34	104-7048	1	Cap-Housing
15:3	137-3838	1	Decal-Side, RH	35	2412-120	2	Clamp-R
15:4	107-8495	1	Decal-Brake, Parking	36	3269-17	2	Rivet-Pop
15:5	139-1271	1	Decal-Brake, Parking	37	94-2413	5	Nut-U
16	137-7652-03	1	Plate-Reverse	39	139-1259-03	1	Guard-Tower
17	114-1337	2	Spacer-Spring	40	105-4886	2	Nut-Tinnerman
18	98-8425	1	Spring-Torsion, LH	41	107-3154	2	Nut-Push
19	137-7695	1	Spring-Torsion	42	139-1288-03	1	Spacer-Cover
20	323-11	2	Screw-HH	43	3234-17	4	Screw-HHF

Track Assembly

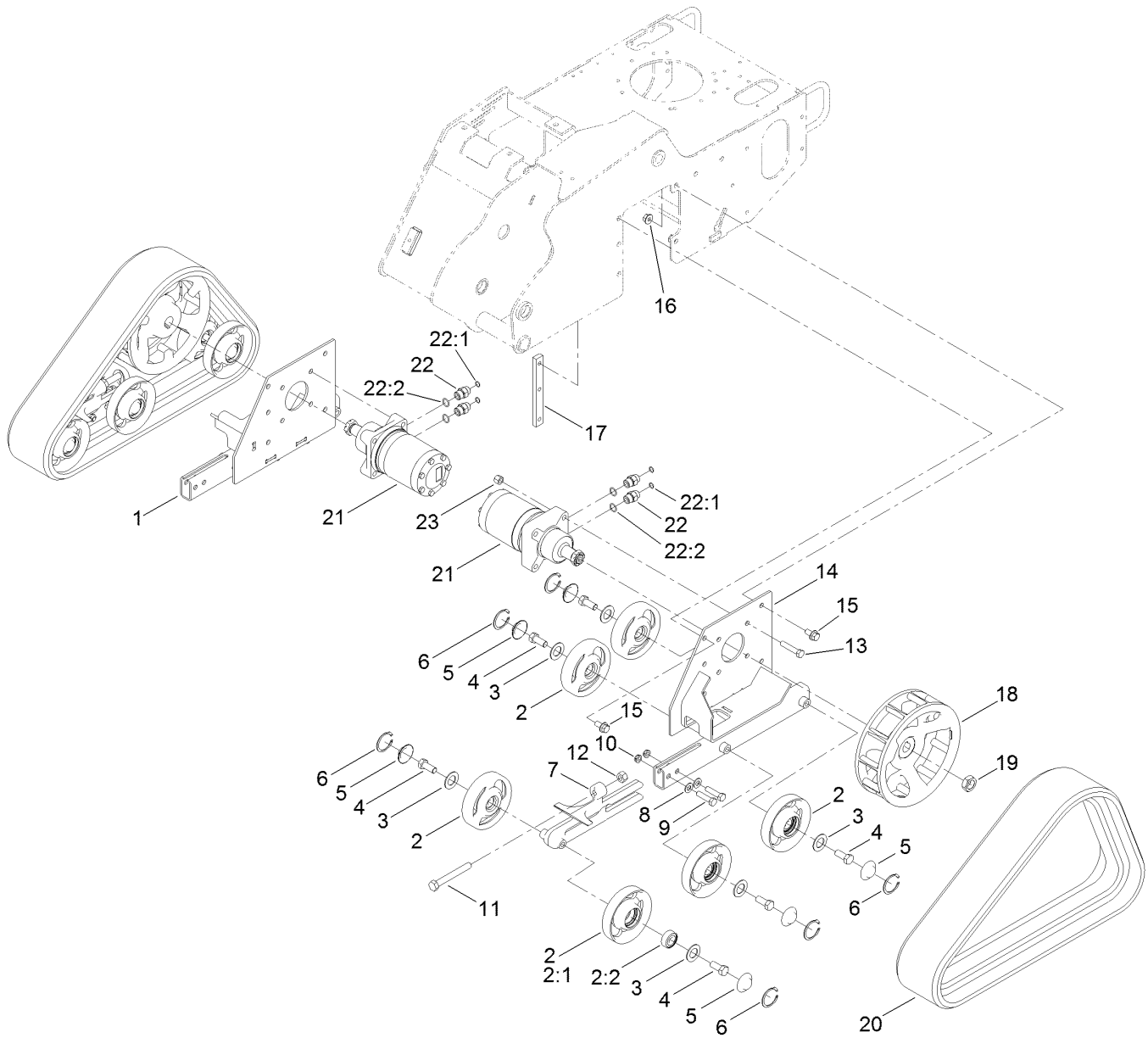

Track Assembly (continued)

<i>Ref.</i>	<i>Part Number</i>	<i>Qty.</i>	<i>Description</i>	<i>Ref.</i>	<i>Part Number</i>	<i>Qty.</i>	<i>Description</i>
1	114-2993-03	1	Frame-Track, RH	13	325-10	8	Screw-HH
2	138-3139	12	Tensioner Wheel ASM	14	114-2992-03	1	Frame-Track, LH
2:1	138-7118	1	Wheel-Track	15	3234-6	10	Screw-HHF
2:2	120-5378	1	Bearing-Ball	16	32128-49	4	Nut-HHF
3	106-7585	12	Gasket-Bogie	17	114-3091	2	Bar-Thread
4	327-4	12	Screw-HH	18	117-6426-03	2	Wheel-Drive
5	106-7557	12	Cap-Wheel, Bearing	19	106-8159	2	Nut-Lock
6	106-7595	12	Ring-Snap, Internal	20	112-4816	2	Track-Rubber
7	114-3077-03	2	Tensioner-Track	21	137-3866	2	Wheel Motor ASM
8	3256-26	4	Washer-Flat	22	340-6	4	Fitting-Straight
9	325-8	4	Screw-HH	22:1	237-30	1	O-Ring
10	3296-45	4	Nut-Hex	22:2	237-80	1	O-Ring
11	112-4874	2	Screw-HH, TAP	23	3296-23	8	Nut-Lock, NI
12	3217-11	2	Nut-Hex				

Brake Linkage Assembly

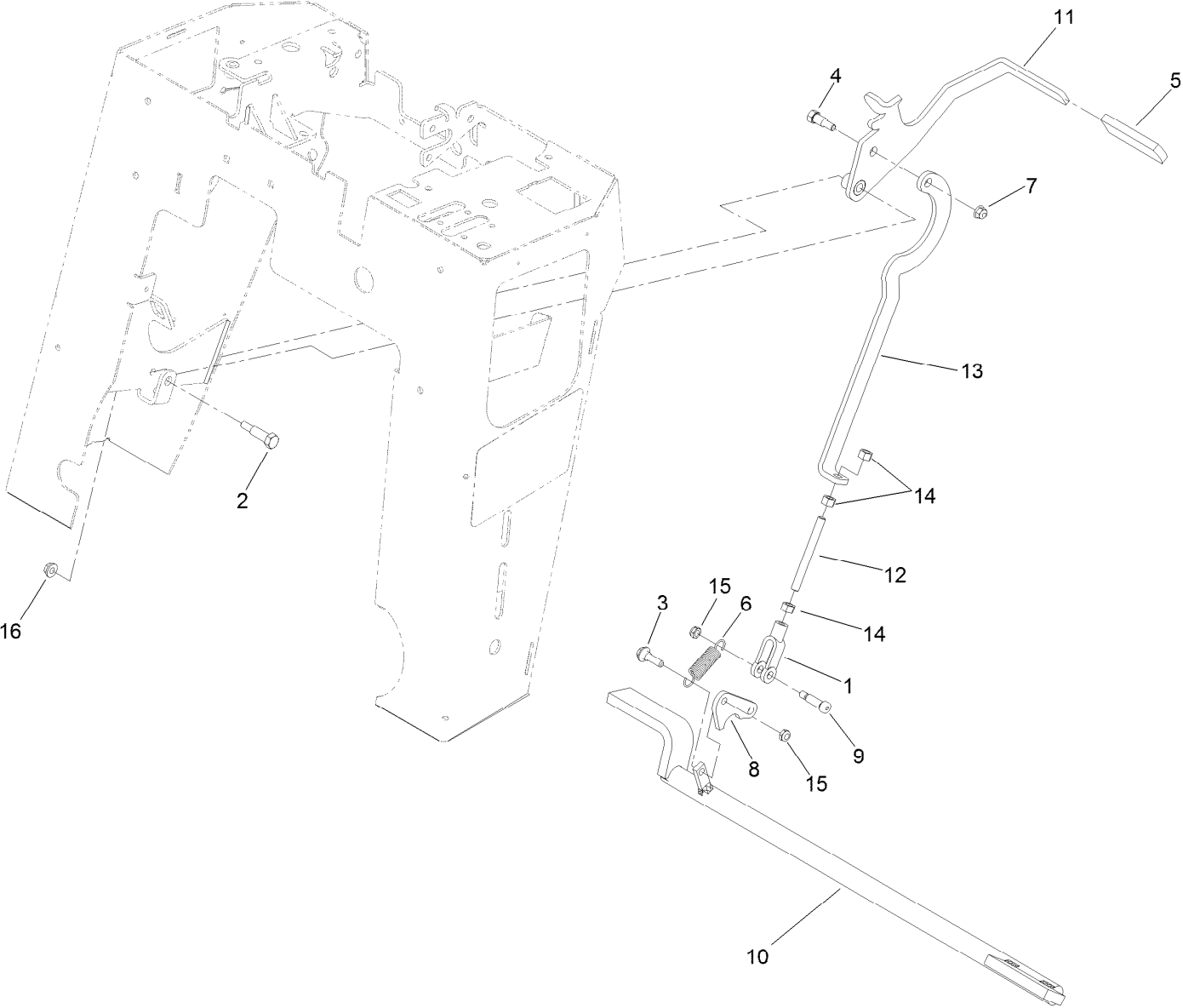

Brake Linkage Assembly (continued)

<i>Ref.</i>	<i>Part Number</i>	<i>Qty.</i>	<i>Description</i>	<i>Ref.</i>	<i>Part Number</i>	<i>Qty.</i>	<i>Description</i>
1	1-633131	1	Yoke-Linkage, Brake	9	114-8629	1	Bolt-Shoulder
2	7-0030	1	Screw-Shoulder, HH	10	121-6240-03	1	Bar-Brake
3	27-7211	1	Screw-Shoulder	11	121-6242-03	1	Handle-Brake
4	28-0540	1	Bolt-Shoulder	12	121-6243	1	Rod-Threaded
5	62-9130	1	Grip-Handle	13	121-6245-03	1	Plate-Brake
6	67-1450	1	Spring-Idler	14	3219-3	3	Nut-Hex
7	104-8300	1	Nut-HF, NI	15	3296-47	2	Nut-Lock, NI
8	114-2975	1	Link-Mounting	16	32128-20	1	Nut-HF

Engine, Muffler and Air Cleaner Assembly

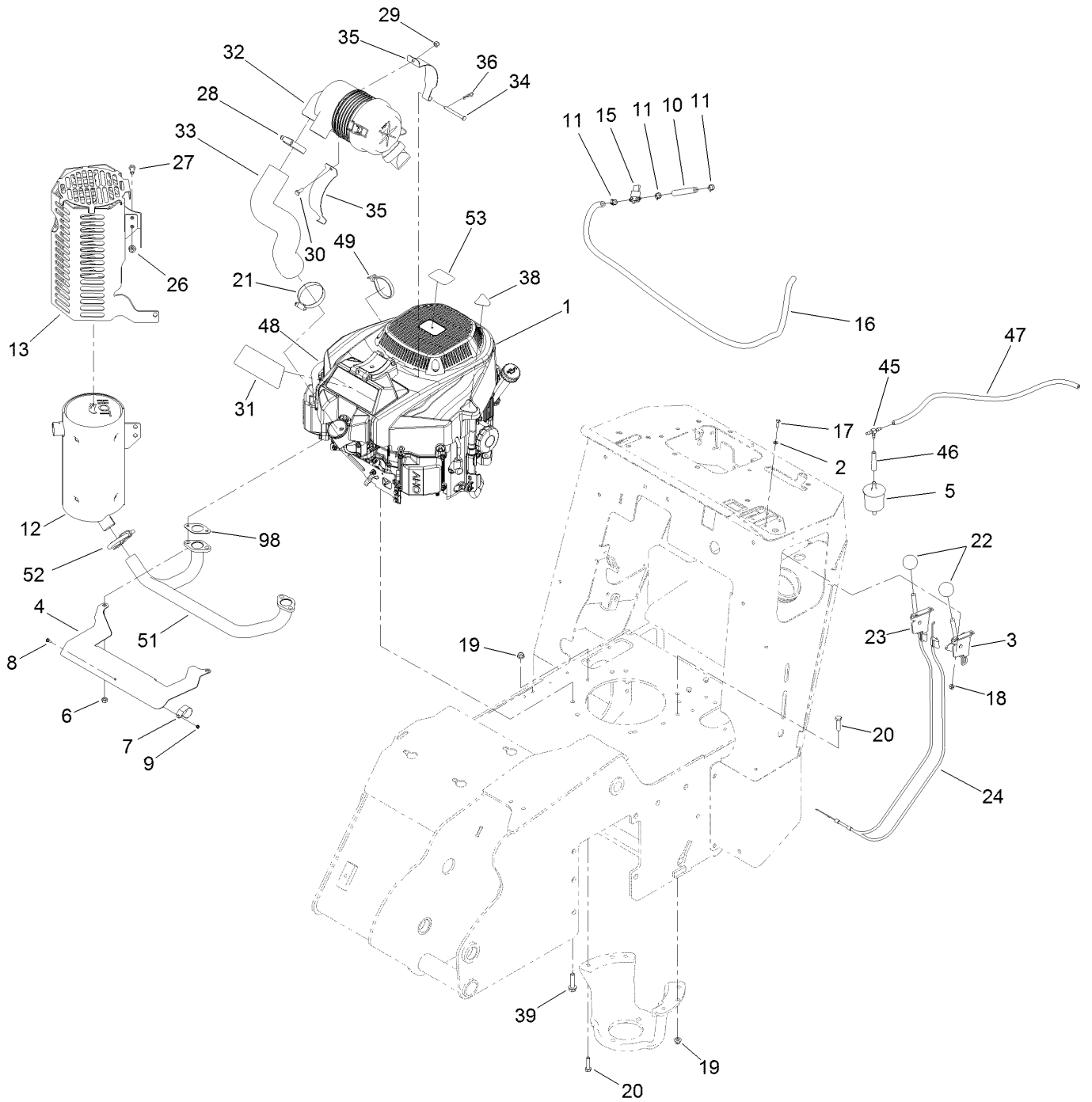

Engine, Muffler and Air Cleaner Assembly (continued)

<i>Ref.</i>	<i>Part Number</i>	<i>Qty.</i>	<i>Description</i>	<i>Ref.</i>	<i>Part Number</i>	<i>Qty.</i>	<i>Description</i>
1	139-0722	1	Engine	26	32128-26	2	Nut-Flange
2	3256-21	4	Washer-Flat	27	322-3	2	Screw-HH
3	110-5547	1	Lever-Control	28	1-643009	1	Clamp-Hose
4	137-3748	1	Plate-Shield, Heat	29	137-3088	1	Nut-Hex
5	120-2235	1	Filter-Fuel	30	137-3041	1	Screw-HH
6	114-3549	4	Nut	31	140-2715	1	Decal
7	115-6488	1	Clamp	32	93-2190	1	Air Cleaner ASM
8	115-6494	1	Screw-Pan	33	136-9242	1	Hose-Intake
9	115-6495	1	Nut-Hex	34	137-2011	2	Pin-Clevis
10	109-0295	1	Hose-Fuel	35	136-9243	2	Strap-Canister, Air
11	2412-98	4	Clamp-Hose	36	1-806003	2	Pin-Cotter
12	138-7136	1	Muffler	38	131-1097	1	Decal-Drain, Oil
13	139-1308-03	1	Guard-Muffler	39	32144-102	4	Screw-HWH
15	1-603770	1	Valve-Fuel	45	120-2234	1	Fitting-Tee
16	109-3491	1	Hose-Fuel	46	120-2272	1	Hose-Fuel, Molded
17	3290-134	4	Screw	47	119-8150	1	Hose-Fuel
18	120-4578	4	Nut-HF	48	131-0736	1	Sleeve-Thermal
19	32128-20	2	Nut-HF	49	3334-945	1	Tie-Cable
20	322-6	2	Screw-HH	51	138-7137	1	Manifold
21	2412-130	1	Clamp-Hose	52	2112-11	1	Clamp-Muffler
22	233-42	2	Knob	53	110-1136	1	Decal
23	108-9730	1	Lever-Control	98	120-4317	2	Gasket-Exhaust
24	115-1211	2	Cable-Control				

Air Cleaner Assembly No. 93-2190

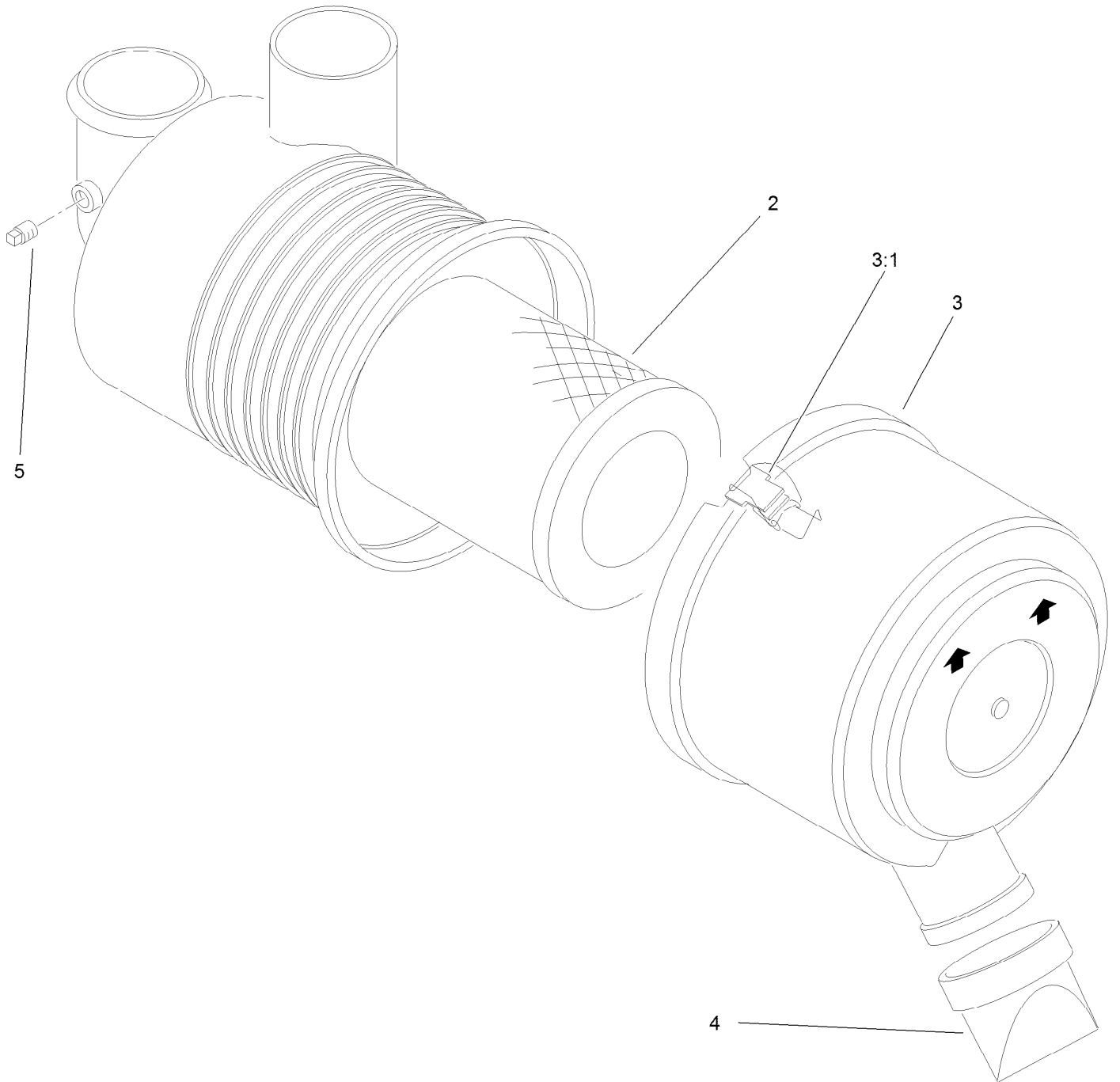

Air Cleaner Assembly No. 93-2190 (continued)

<i>Ref.</i>	<i>Part Number</i>	<i>Qty.</i>	<i>Description</i>	<i>Ref.</i>	<i>Part Number</i>	<i>Qty.</i>	<i>Description</i>
2	108-3811	1	Filter-Air	4	87-9400	1	Valve-Vacuator
3	94-3652	1	Cover ASM	5	285-17	1	Plug-Pipe
3:1	1-643283	2	Latch-Cleaner, Air				

Hydraulic Assembly

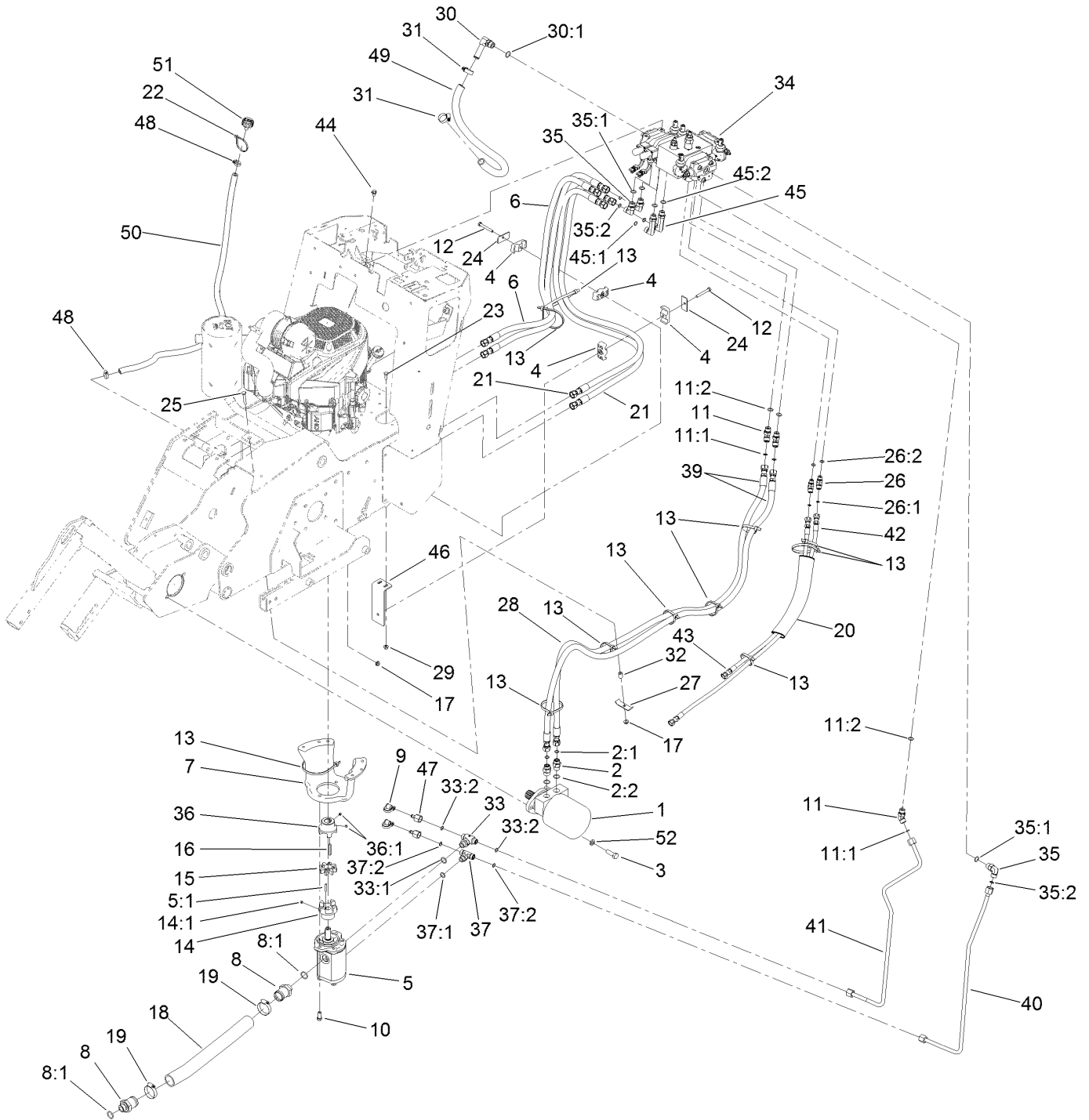

Hydraulic Assembly (continued)

<i>Ref.</i>	<i>Part Number</i>	<i>Qty.</i>	<i>Description</i>	<i>Ref.</i>	<i>Part Number</i>	<i>Qty.</i>	<i>Description</i>
1	117-6306	1	Hydraulic Motor ASM	27	100-4860	1	Bracket-Clamp
2	340-6	2	Fitting-Straight	28	99-5648	2	Sleeve-Protective
2:1	237-30	1	O-Ring	29	104-8300	2	Nut-HF, NI
2:2	237-80	1	O-Ring	30	87-8170	1	Fitting-90
3	325-6	2	Screw-HH	30:1	237-80	1	O-Ring
4	94-8105	6	Clamp-Tube	31	2412-129	2	Clamp-Hose
5	137-7630	1	Pump-HYD	32	93-5023	1	Spacer
5:1	27-8590	1	Key-Square	33	130-8775	1	Fitting-HYD
6	137-7682	2	Hydraulic Hose ASM	33:1	237-80	1	O-Ring
7	137-7634-03	1	Mount-Pump	33:2	237-30	2	O-Ring
8	138-7126	2	Fitting-STR	34	137-7646	1	Valve ASM
8:1	237-81	1	O-Ring	35	340-98	3	Fitting-Elbow, 90 DEG
9	354-79	2	Cap-Dust	35:1	237-79	1	O-Ring
10	324-4	2	Screw-HH	35:2	237-30	1	O-Ring
11	340-101	3	Fitting-HYD, 45 DEG	36	138-7101	1	Hub-Flex
11:1	237-30	1	O-Ring	36:1	105-4068	2	Screw-Set, HSH
11:2	237-79	1	O-Ring	37	340-157	1	Fitting-HYD, Tee
12	322-11	3	Screw-HH	37:1	237-79	1	O-Ring
13	3334-945	11	Tie-Cable	37:2	237-30	2	O-Ring
14	114-2933	1	Coupler-Flex	39	137-3730	2	Hydraulic Hose ASM
14:1	105-4068	1	Screw-Set, HSH	40	137-7698	1	HYD Tube ASM
15	93-8827	1	Coupler-Spider	41	137-3724	1	HYD Tube ASM
16	608006	1	Key-Square	42	137-3731	1	Hydraulic Hose ASM
17	32128-20	4	Nut-HF	43	137-3732	1	Hose-HYD
18	138-7128	1	Hose-Suction, HYD	44	68-9410	3	Screw-HHF
19	2412-130	2	Clamp-Hose	45	99-6160	2	Fitting-Elbow, 90 Long
20	115-4064	1	Sleeve-Protective	45:1	237-30	1	O-Ring
21	137-7680	2	Hydraulic Hose ASM	45:2	237-79	1	O-Ring
22	3290-379	1	Tie-Cable	46	137-3736-03	1	Bracket-Support, Hose
23	322-4	2	Screw-HH	47	100-5616	2	Fitting
24	69-9761	3	Plate-Cover	48	2412-36	2	Clamp-Hose
25	322-10	1	Screw-HH	49	138-3197	1	Hose-Cooler
26	340-87	2	Fitting-Elbow, 45 DEG	50	114-3042	1	Hose-Breather
26:1	237-22	1	O-Ring	51	68-6150	1	Breather
26:2	237-42	1	O-Ring	52	3253-7	2	Washer-Lock

Hydraulic Motor Assembly No. 117-6306

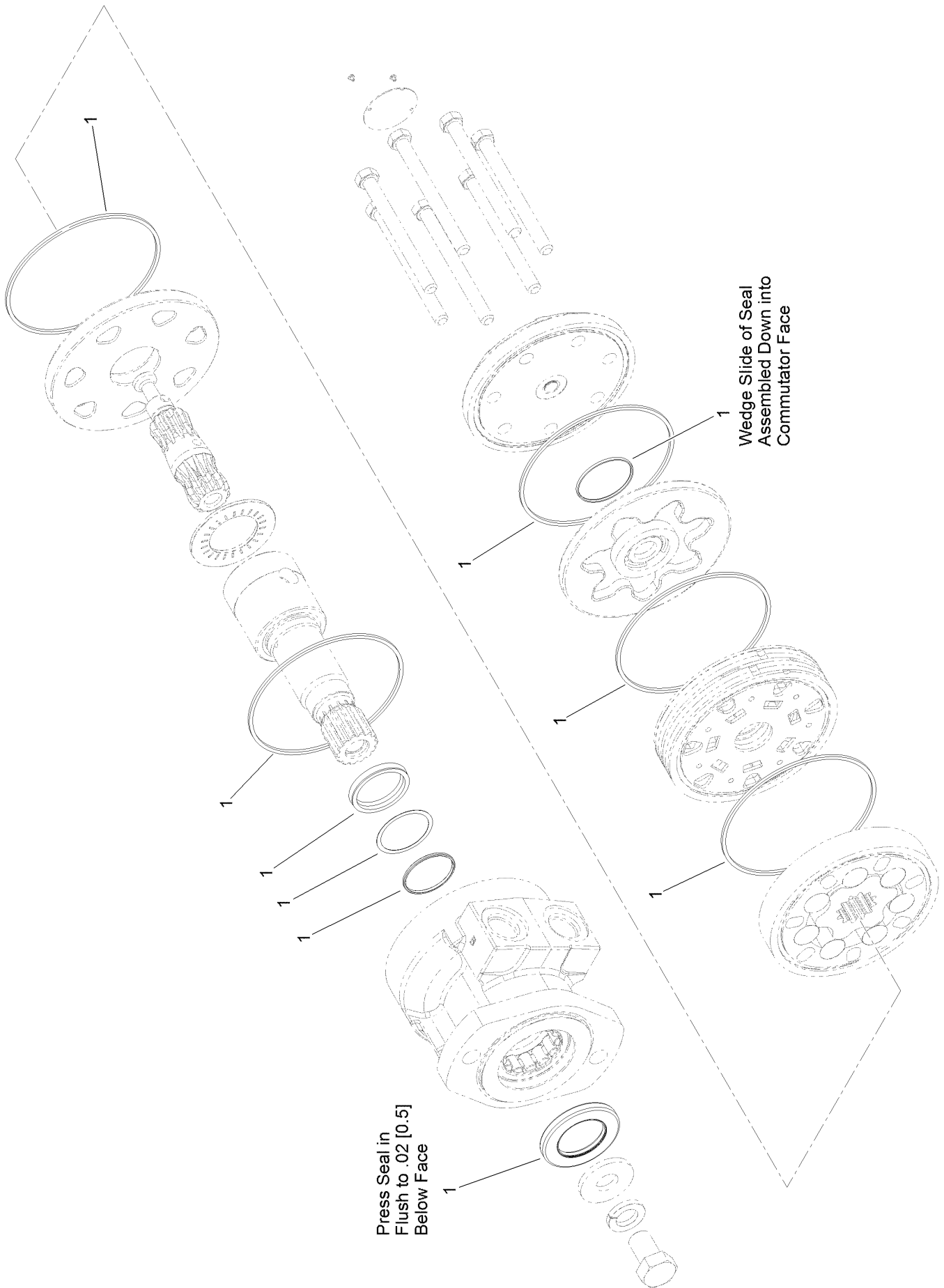

Hydraulic Motor Assembly No. 117-6306 (continued)

<i>Ref.</i>	<i>Part Number</i>	<i>Qty.</i>	<i>Description</i>
1	115-4061	1	Seal Kit

Valve Assembly No. 137-7646

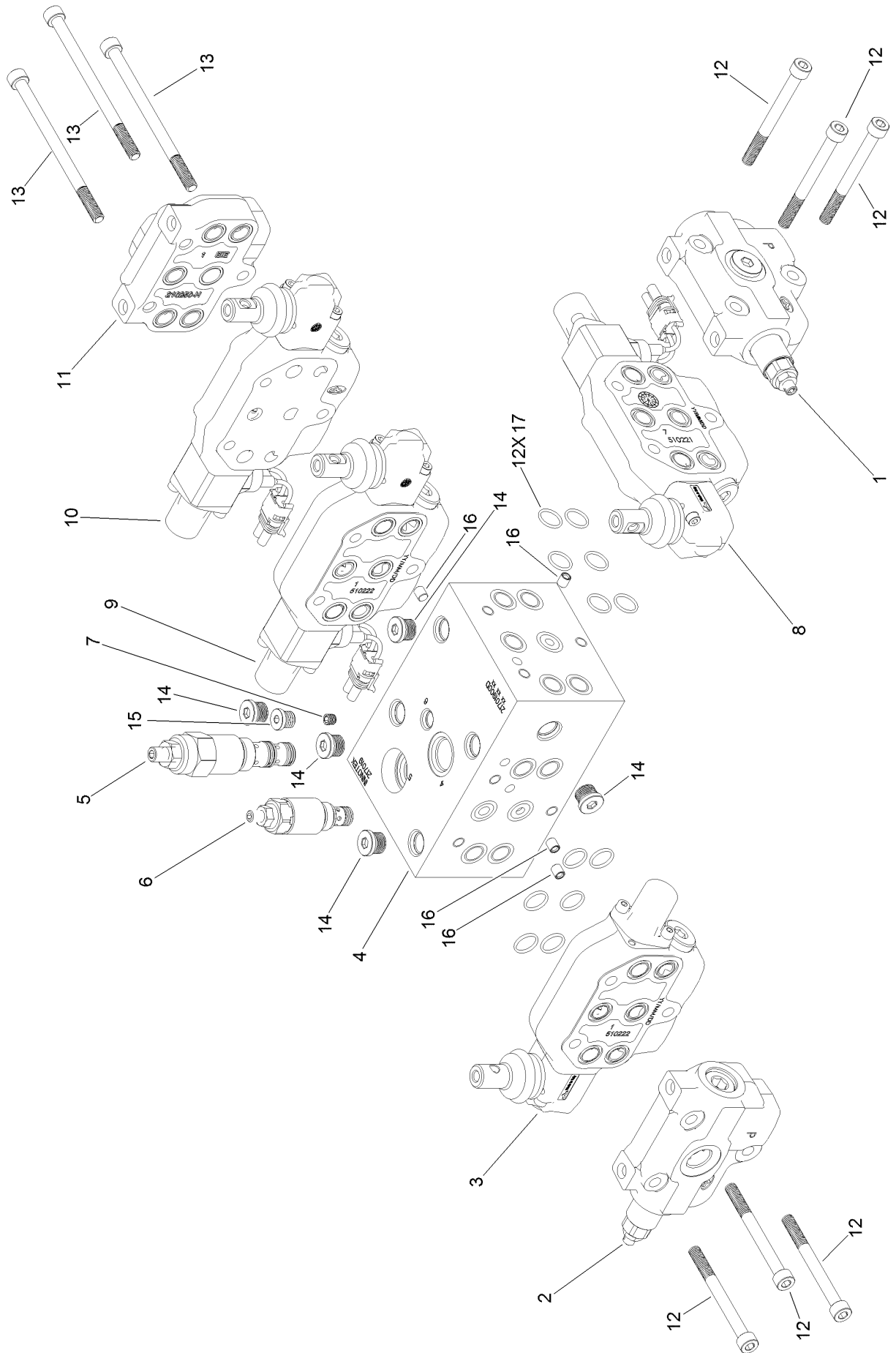

Valve Assembly No. 137-7646 (continued)

<i>Ref.</i>	<i>Part Number</i>	<i>Qty.</i>	<i>Description</i>	<i>Ref.</i>	<i>Part Number</i>	<i>Qty.</i>	<i>Description</i>
1	139-1337	1	Section-Inlet	10	139-1346	1	Section-Valve, Parallel
2	139-1338	1	Section-Inlet	11	139-1347	1	Section-Outlet
3	139-1339	1	Section-Valve, Series	12	139-1348	6	Screw-HSH
4	139-1340	1	Block-Manifold	13	139-1349	3	Screw-HSH
5	139-1341	1	Valve-Directional, Unloading	14	131-3807	5	Plug
6	139-1342	1	Valve-Relief	15	131-3806	1	Plug
7	139-1343	1	Plug-Orifice	16	140-1100	4	Plug-Expansion
8	139-1344	1	Section-Valve, Parallel	17	140-1101	12	O-Ring
9	139-1345	1	Section-Valve, Series				

Valve Inlet Section Assembly No. 139-1337

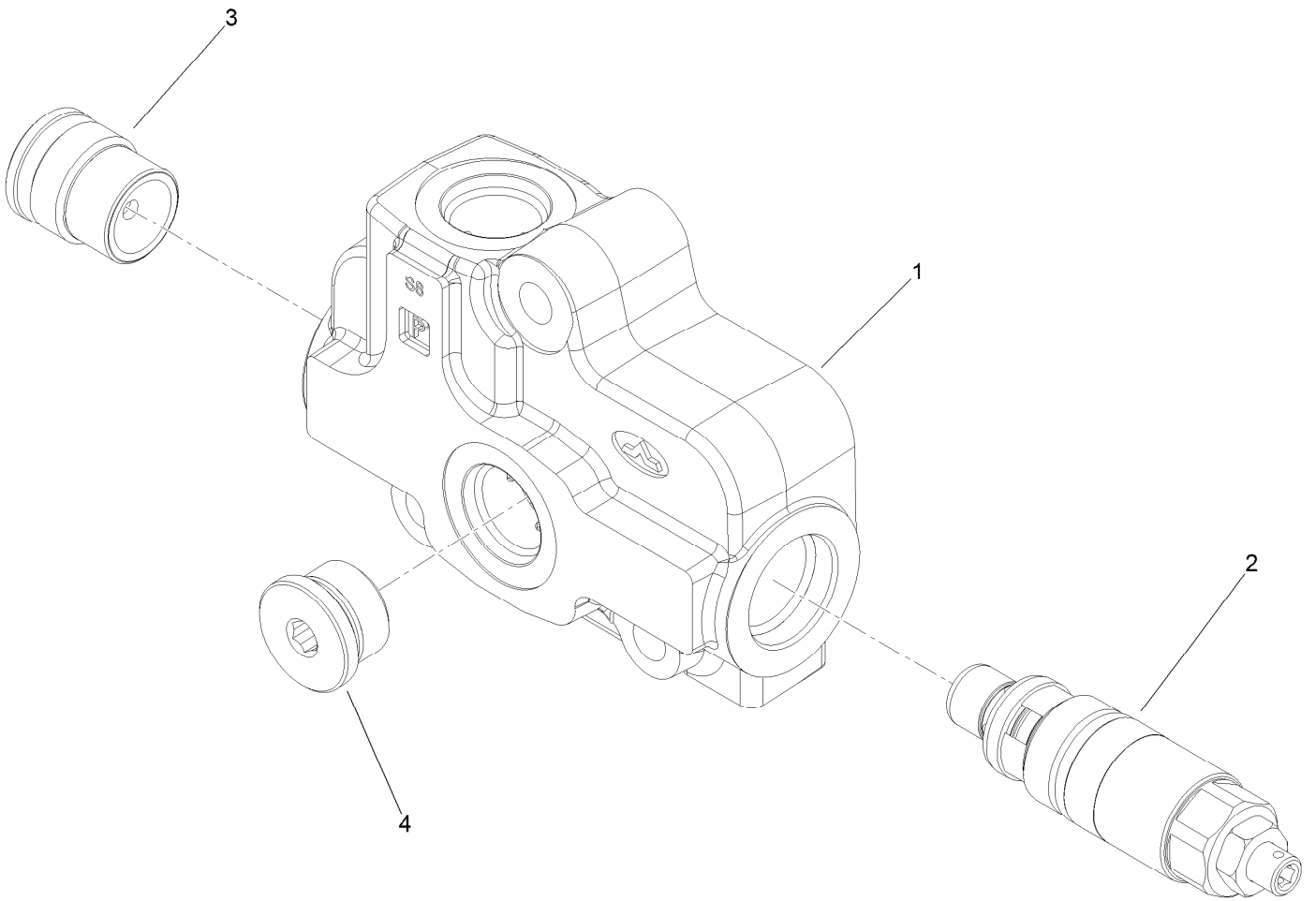

Valve Inlet Section Assembly No. 139-1337 (continued)

<i>Ref.</i>	<i>Part Number</i>	<i>Qty.</i>	<i>Description</i>
1	140-1102	1	Inlet
2	132-6039	1	Valve-Relief

<i>Ref.</i>	<i>Part Number</i>	<i>Qty.</i>	<i>Description</i>
3	140-1103	1	Plug
4	140-1104	1	Plug

Valve Inlet Section Assembly No. 139-1338

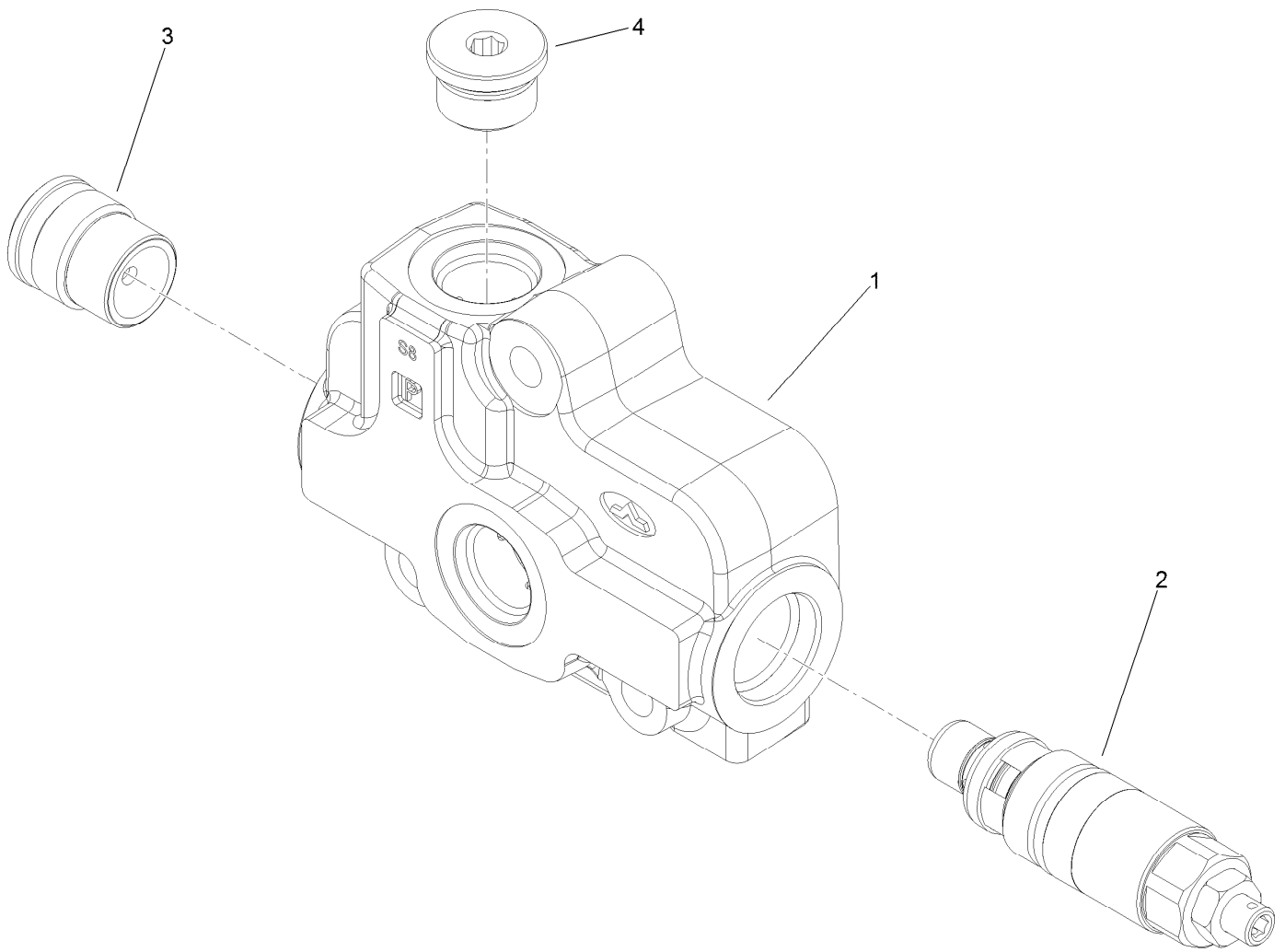

Valve Inlet Section Assembly No. 139-1338 (continued)

<i>Ref.</i>	<i>Part Number</i>	<i>Qty.</i>	<i>Description</i>
1	140-1102	1	Inlet
2	132-6039	1	Valve-Relief

<i>Ref.</i>	<i>Part Number</i>	<i>Qty.</i>	<i>Description</i>
3	140-1103	1	Plug
4	140-1104	1	Plug

Series Valve Section Assembly No. 139-1339

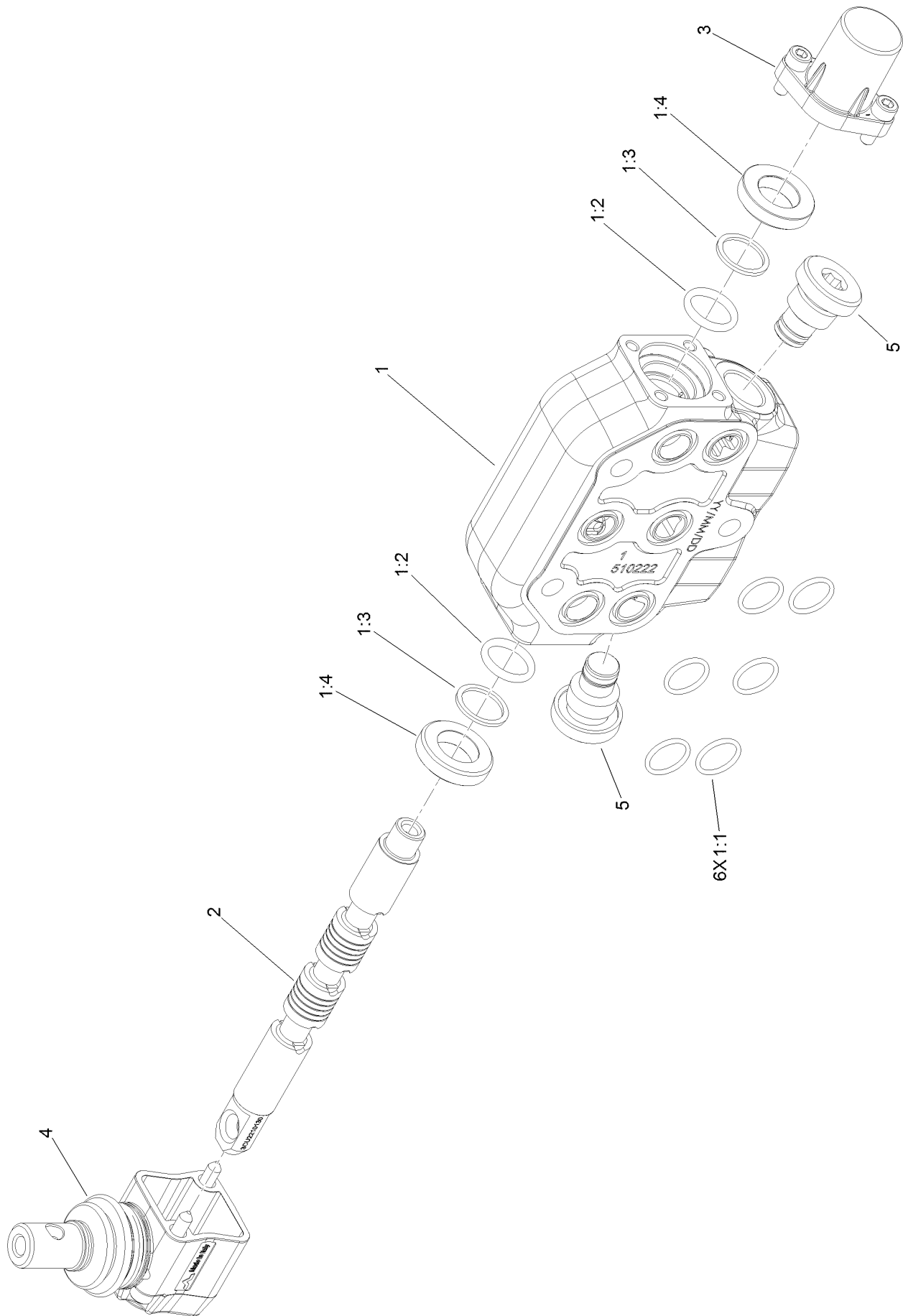

Series Valve Section Assembly No. 139-1339 (continued)

<i>Ref.</i>	<i>Part Number</i>	<i>Qty.</i>	<i>Description</i>	<i>Ref.</i>	<i>Part Number</i>	<i>Qty.</i>	<i>Description</i>
1	140-1109	1	Section-Working	2	140-1105	1	Valve-Spool
1:1	140-1114	6	O-Ring	3	140-1110	1	Kit-Control
1:2	106-7719	2	Seal-Valve	4	140-1107	1	Lever-Valve
1:3	140-1116	2	Seal-Valve	5	140-1108	2	Plug
1:4	140-1117	2	Seal-Valve				

Parallel Valve Section Assembly No. 139-1344

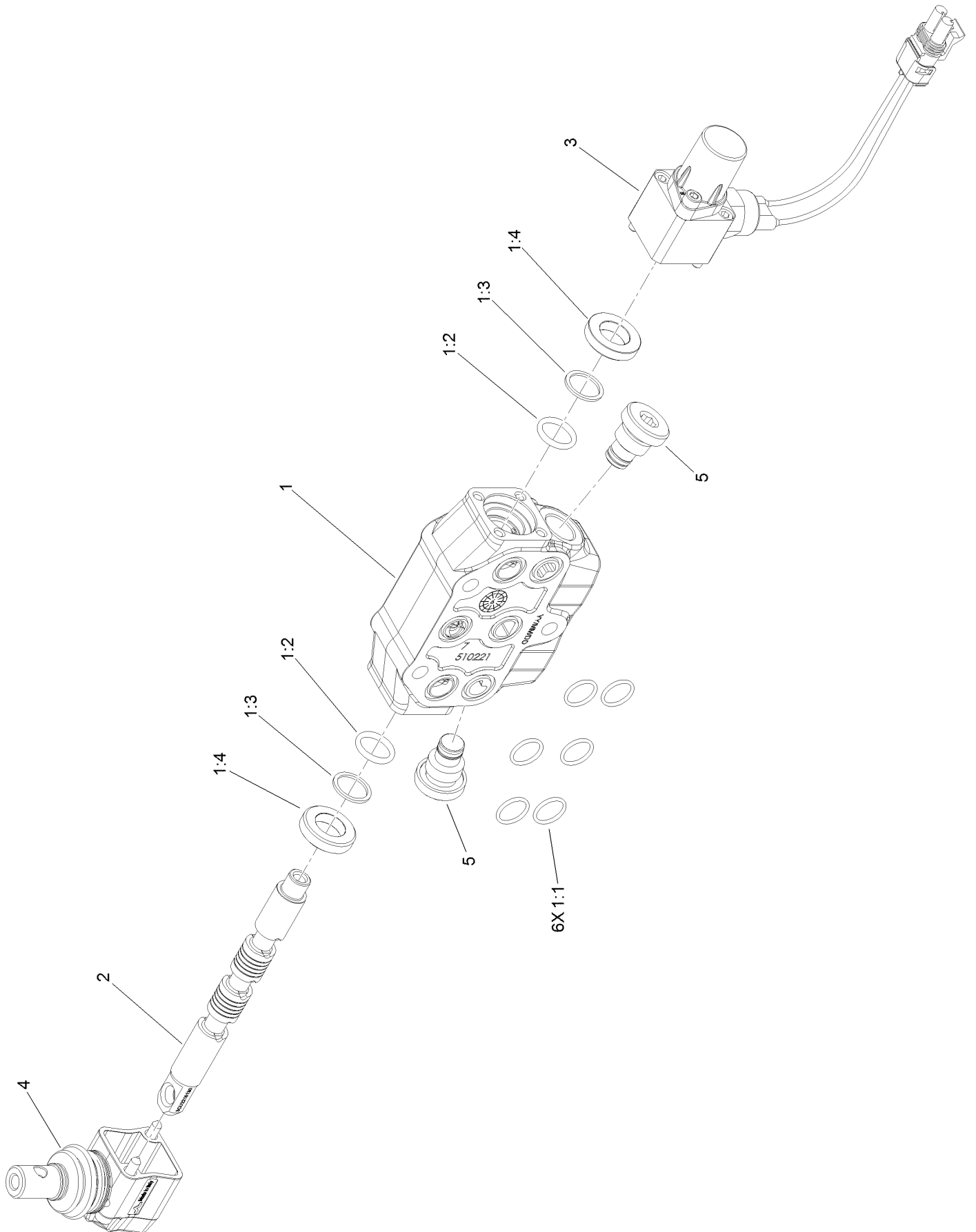

Parallel Valve Section Assembly No. 139-1344 (continued)

<i>Ref.</i>	<i>Part Number</i>	<i>Qty.</i>	<i>Description</i>	<i>Ref.</i>	<i>Part Number</i>	<i>Qty.</i>	<i>Description</i>
1	140-1115	1	Section-Working	2	140-1105	1	Valve-Spool
1:1	140-1114	6	O-Ring	3	140-1106	1	Kit-Control
1:2	106-7719	2	Seal-Valve	4	140-1107	1	Lever-Valve
1:3	140-1116	2	Seal-Valve	5	140-1108	2	Plug
1:4	140-1117	2	Seal-Valve				

Series Valve Section Assembly No. 139-1345

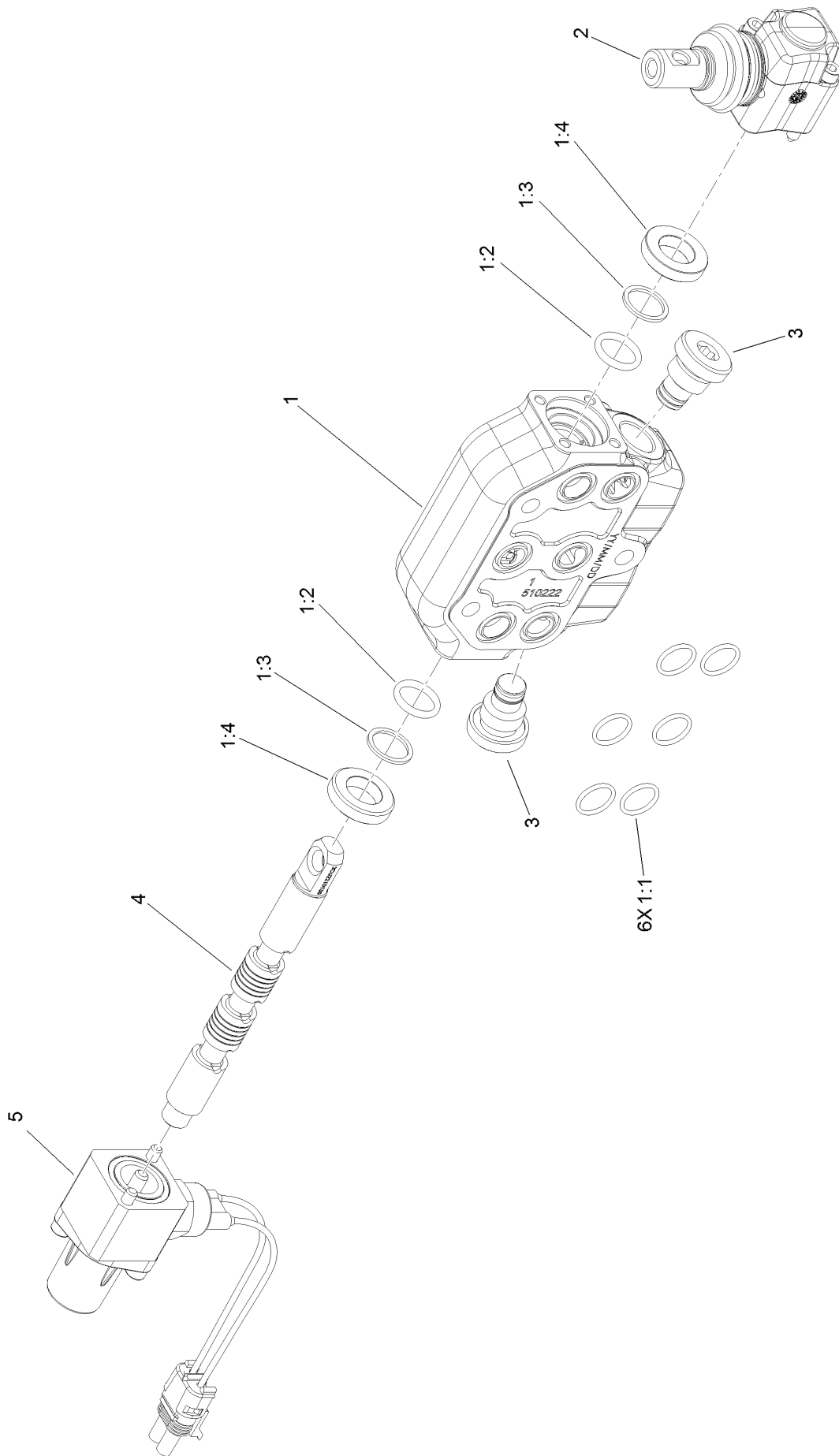

Series Valve Section Assembly No. 139-1345 (continued)

<i>Ref.</i>	<i>Part Number</i>	<i>Qty.</i>	<i>Description</i>	<i>Ref.</i>	<i>Part Number</i>	<i>Qty.</i>	<i>Description</i>
1	140-1118	1	Section-Working	2	140-1107	1	Lever-Valve
1:1	140-1114	6	O-Ring	3	140-1108	2	Plug
1:2	106-7719	2	Seal-Valve	4	140-1105	1	Valve-Spool
1:3	140-1116	2	Seal-Valve	5	140-1106	1	Kit-Control
1:4	140-1117	2	Seal-Valve				

Parallel Valve Section Assembly No. 139-1346

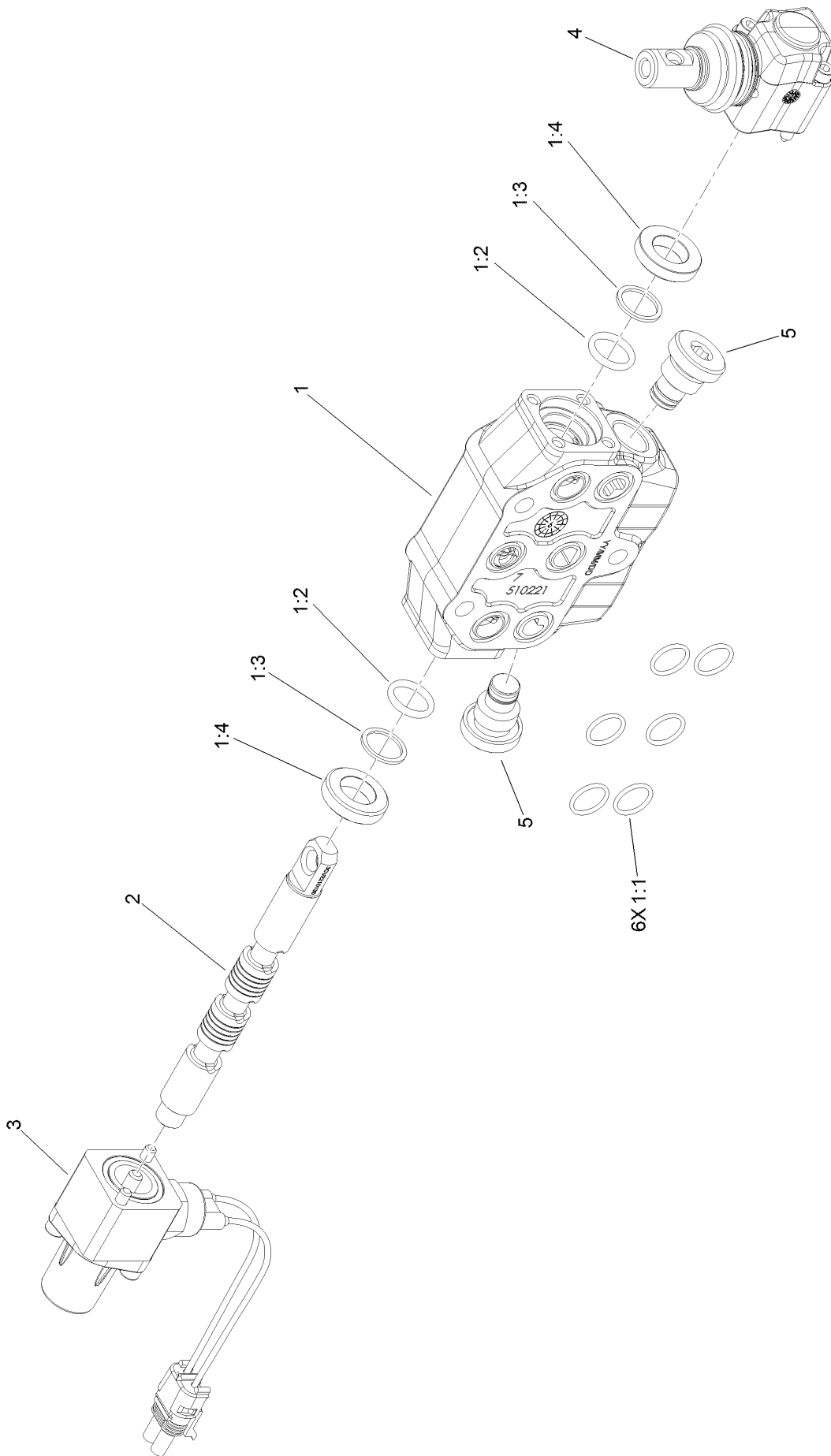

Parallel Valve Section Assembly No. 139-1346 (continued)

<i>Ref.</i>	<i>Part Number</i>	<i>Qty.</i>	<i>Description</i>	<i>Ref.</i>	<i>Part Number</i>	<i>Qty.</i>	<i>Description</i>
1	140-1115	1	Section-Working	2	140-1105	1	Valve-Spool
1:1	140-1114	6	O-Ring	3	140-1106	1	Kit-Control
1:2	106-7719	2	Seal-Valve	4	140-1107	1	Lever-Valve
1:3	140-1116	2	Seal-Valve	5	140-1108	2	Plug
1:4	140-1117	2	Seal-Valve				

Outlet Section Assembly No. 139-1347

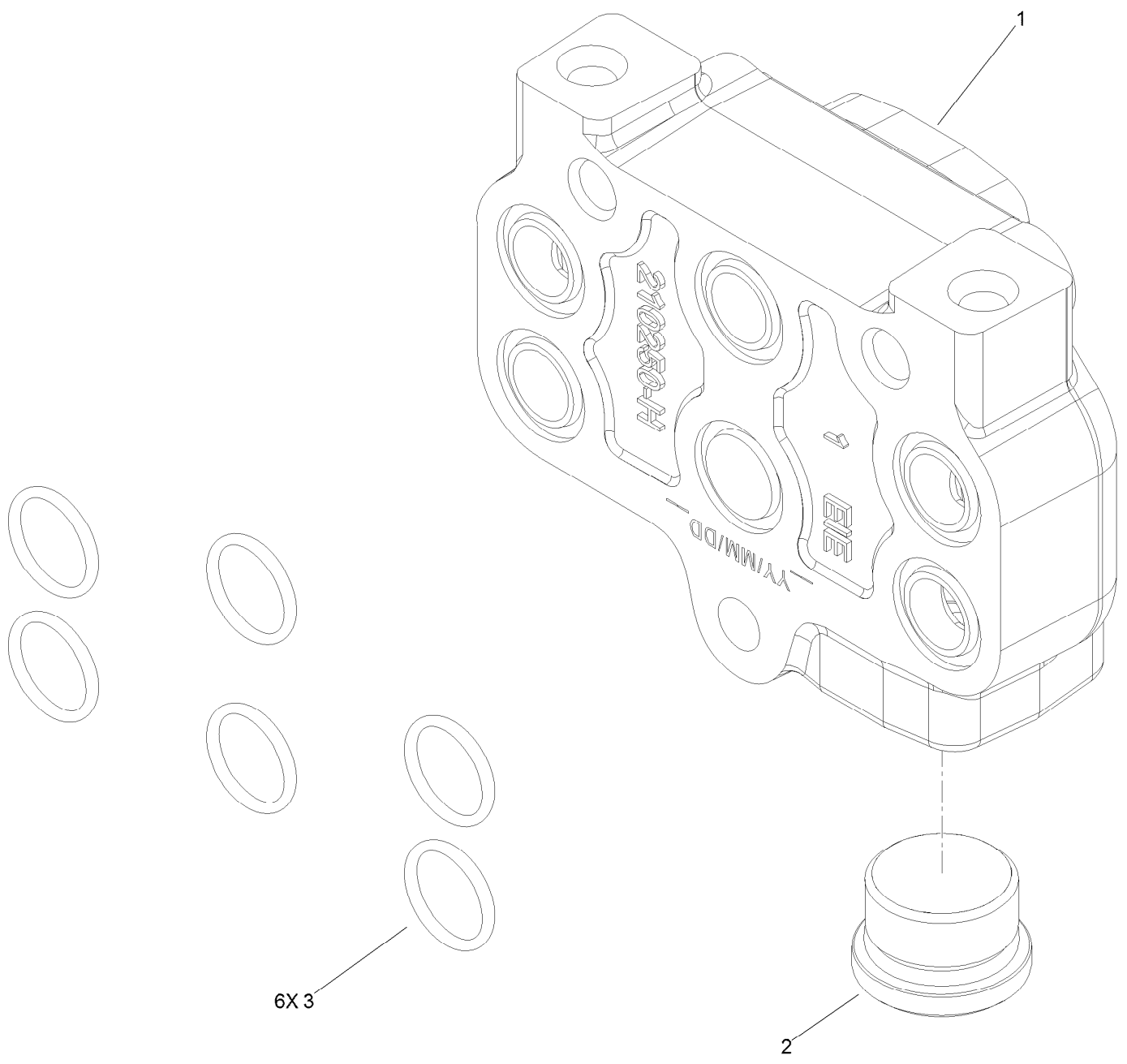

Outlet Section Assembly No. 139-1347 (continued)

<i>Ref.</i>	<i>Part Number</i>	<i>Qty.</i>	<i>Description</i>
1	140-1112	1	Cover-Outlet
2	140-1111	1	Plug
3	140-1114	6	O-Ring

Oil Cooler Assembly

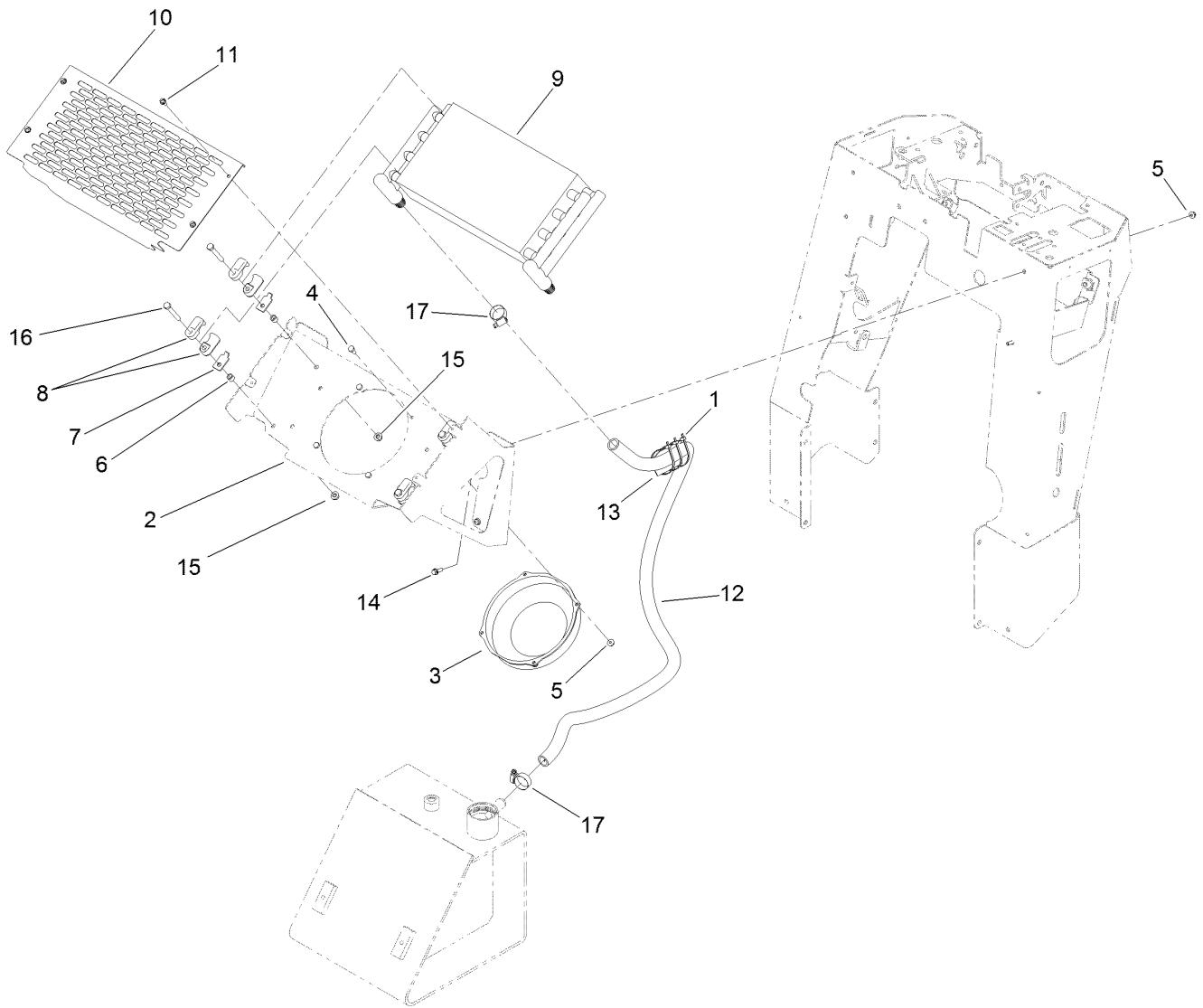

Oil Cooler Assembly (continued)

<i>Ref.</i>	<i>Part Number</i>	<i>Qty.</i>	<i>Description</i>	<i>Ref.</i>	<i>Part Number</i>	<i>Qty.</i>	<i>Description</i>
1	3290-379	3	Tie-Cable	10	119-4633-01	1	Cover-Cooler
2	138-3194-01	1	Mount-Cooler	11	32104-95	4	Screw-HWH
3	104-2809	1	Fan	12	138-3198	1	Hose-Cooler
4	321-3	4	Screw-HH	13	AU112950	1	Protector-Hose
5	104-7201	8	Nut-HF	14	115-5103	4	Screw-HHF
6	105-5723	4	Spacer-Tube	15	104-8300	4	Nut-HF, NI
7	131-0642	4	Plate-Support, Clamp	16	322-11	4	Screw-HH
8	131-0733	8	Clamp	17	2412-129	2	Clamp-Hose
9	117-6320	1	Cooler-Oil				

Trencher Head and Lift Assembly

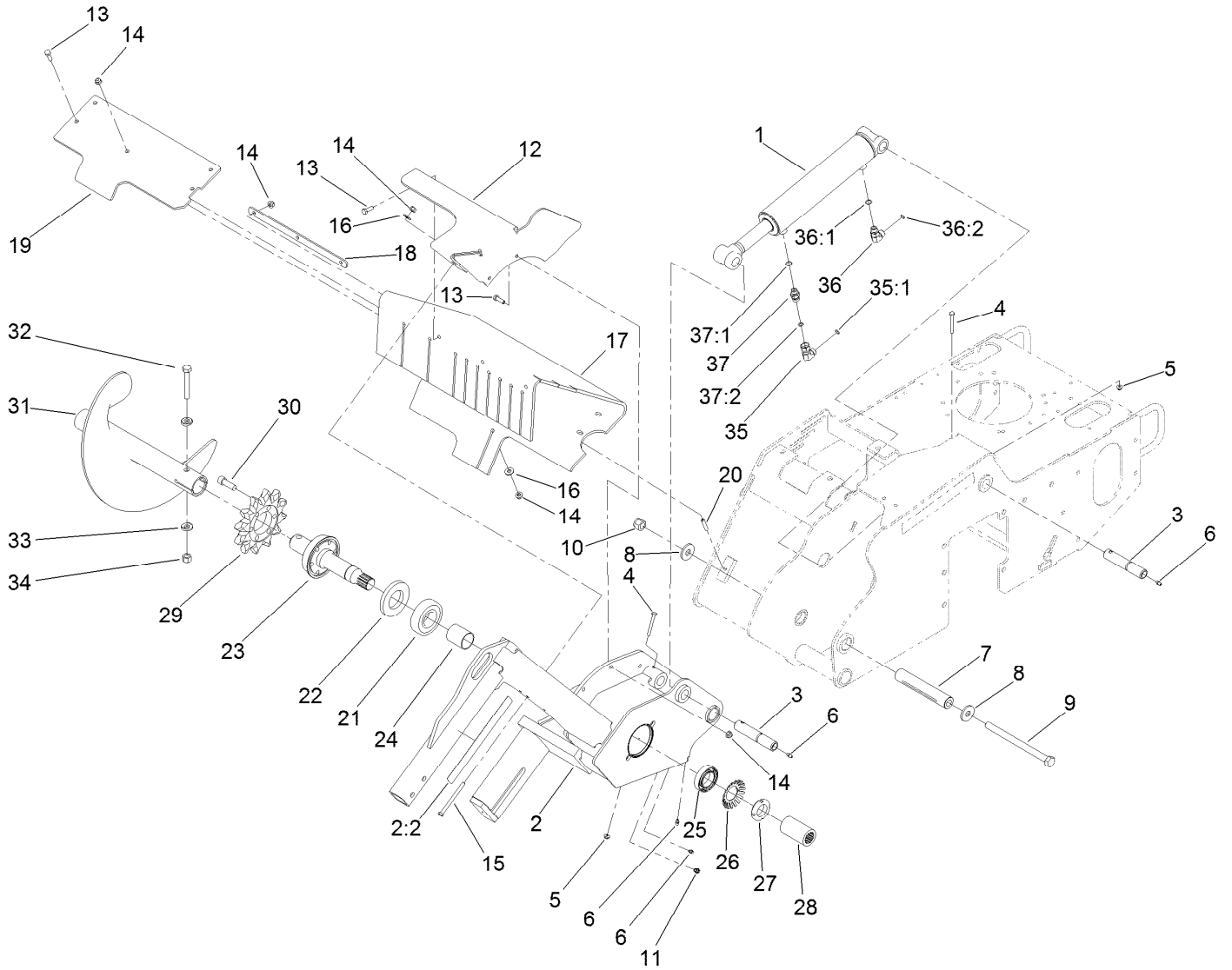

Trencher Head and Lift Assembly (continued)

<i>Ref.</i>	<i>Part Number</i>	<i>Qty.</i>	<i>Description</i>	<i>Ref.</i>	<i>Part Number</i>	<i>Qty.</i>	<i>Description</i>
1	137-3827	1	Hydraulic Cylinder ASM	22	114-2955	1	Seal-Grease
2	117-6423	1	Trencher Head ASM	23	117-6308	1	Shaft-Trencher
2:2	99-9952	2	Decal-Danger	24	112-4979	1	Spacer
3	120-7352	2	Pin-Pivot	25	111199	1	Bearing-Ball
4	321-18	2	Screw-HH	26	114-2956	1	Lockwasher-Bearing
5	104-7201	2	Nut-HF	27	88-1450	1	Locknut-Bearing
6	302-5	4	Fitting-Grease	28	117-6315	1	Collar-Splined
7	121-4571	1	Spacer-Pivot	29	104-1964	1	Sprocket-Trencher
8	104-9216	2	Washer-Hardened	30	3274-4	6	Screw-HSH
9	117-6327	1	Bolt-HH	31	137-3737-03	1	Auger-Trencher
10	3296-53	1	Nut-Lock, NI	32	325-13	1	Screw-HH
11	302-34	1	Fitting-Lube	33	117-3479	2	Washer-Saddle
12	115-1279-03	1	Bracket-Shield	34	3296-23	1	Nut-Lock, NI
13	322-5	8	Screw-HH	35	340-159	1	Elbow-90
14	104-8300	11	Nut-HF, NI	35:1	237-22	2	O-Ring
15	322-23	1	Screw-HH	36	340-77	1	Fitting-Elbow, 90 DEG
16	3256-3	4	Washer-Flat	36:1	237-22	1	O-Ring
17	117-6317	1	Shield-Dirt	36:2	237-42	1	O-Ring
18	115-4001-03	1	Plate-Strap, Shield	37	115-4081	1	Valve-Check
19	117-6316-03	1	Clamp-Bar	37:1	237-42	1	O-Ring
20	115-4049	2	Screw-HSH	37:2	237-22	1	O-Ring
21	106-8871	1	Bearing-Ball				

Hydraulic Cylinder Assembly No. 137-3827

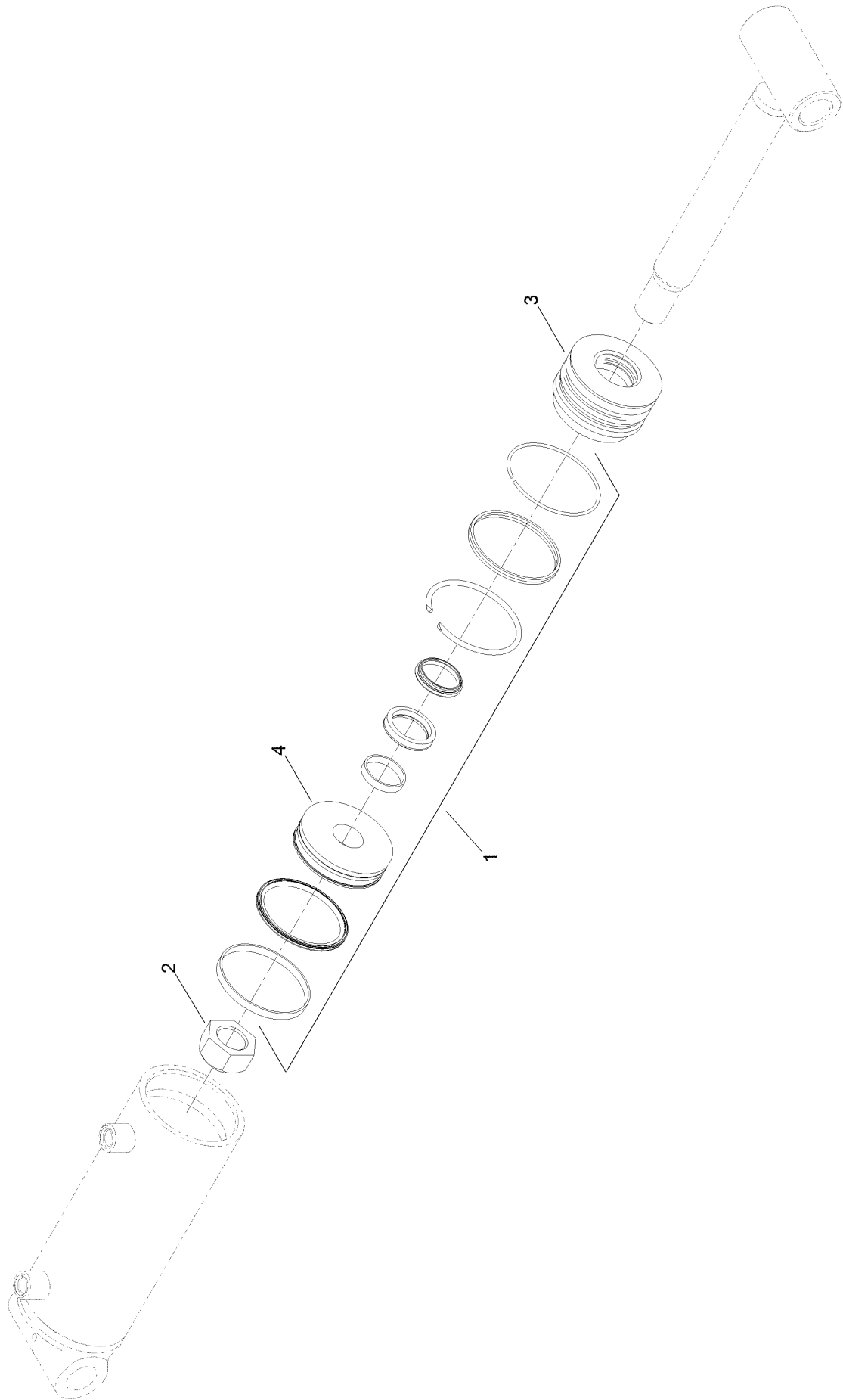

Hydraulic Cylinder Assembly No. 137-3827 (continued)

<i>Ref.</i>	<i>Part Number</i>	<i>Qty.</i>	<i>Description</i>
1	138-7140	1	Seal Kit
2	138-7141	1	Nut-Hex

<i>Ref.</i>	<i>Part Number</i>	<i>Qty.</i>	<i>Description</i>
3	138-7142	1	Head-Cylinder
4	138-7143	1	Piston

Control Assembly

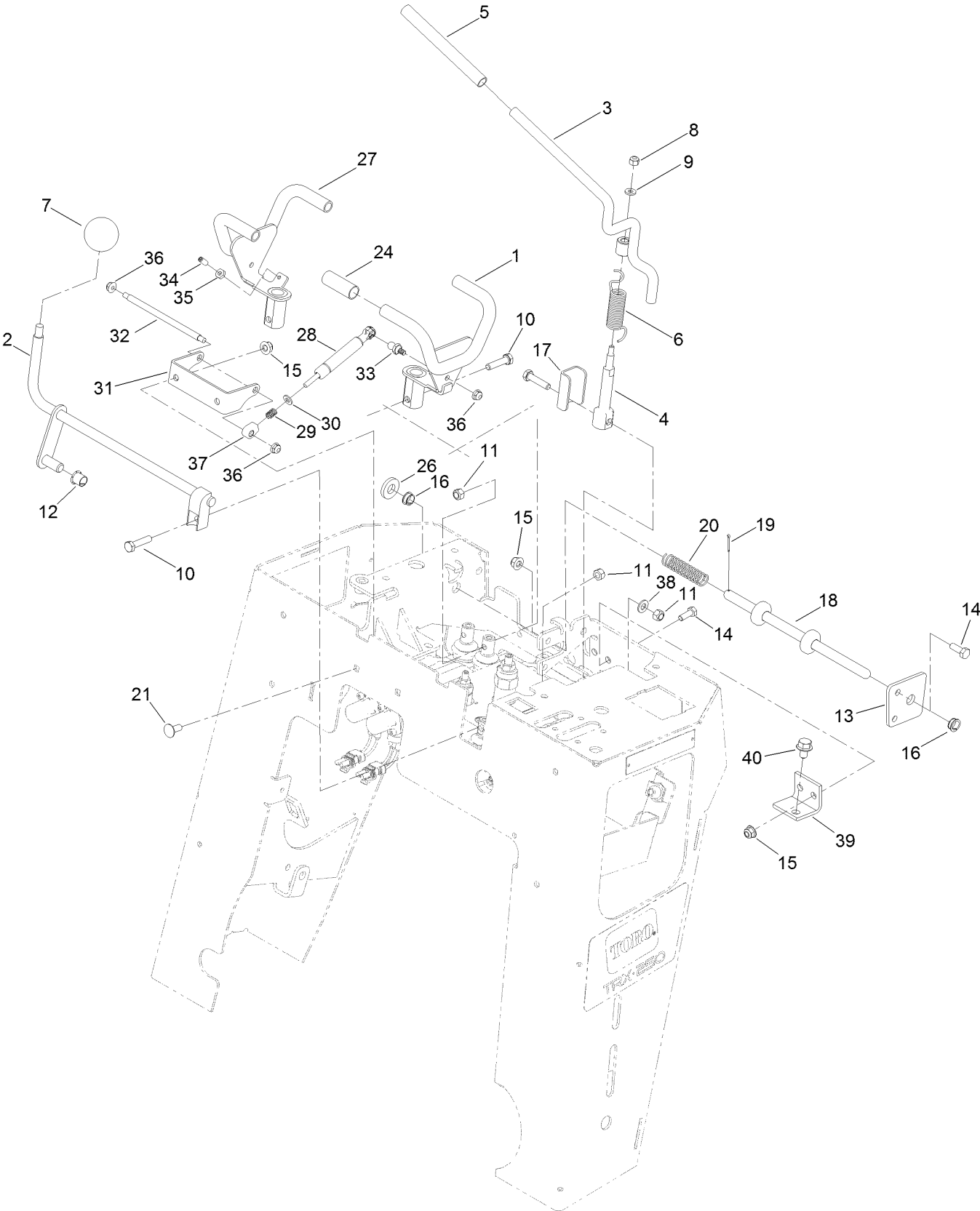

Control Assembly (continued)

<i>Ref.</i>	<i>Part Number</i>	<i>Qty.</i>	<i>Description</i>	<i>Ref.</i>	<i>Part Number</i>	<i>Qty.</i>	<i>Description</i>
1	140-5764-03	1	Handle-Traction, LH	20	95-4256	1	Spring-Compression
2	139-1306	1	Lever-Lift	21	3230-23	2	Bolt-CARR
3	137-7651	1	Lever-Auxiliary	24	139-1307	4	Grip
4	137-7649	1	Lever-Drive, Chain	26	107-3395	1	Washer-Hardened
5	138-3168	1	Grip	27	140-5765-03	1	Handle-Traction, RH
6	112-2738	1	Spring-Torsion	28	139-1314	2	Damper
7	233-21	1	Knob	29	139-1321	2	Spring-Compression
8	3296-42	1	Nut-Lock, NI	30	139-1323	2	Washer-Spcl
9	3256-16	1	Washer-Flat	31	139-1299-03	1	Bracket-Damper
10	33114-035	4	Screw-HH	32	139-1316	1	Rod-Damper
11	33024-00	4	Nut-Lock, NI	33	139-1315	2	Stud-Ball
12	256-257	1	Bushing-Nyliner	34	3245-3	2	Screw-Set, Hs
13	138-3123-03	1	Plate-Bushing	35	3218-1	2	Nut-Jam
14	322-4	4	Screw-HH	36	104-7201	4	Nut-HF
15	104-8300	6	Nut-HF, NI	37	140-1122	2	Fitting-Clevis
16	116-1393	2	Bushing	38	3256-23	1	Washer-Plain
17	138-3124	1	Bracket-Lever	39	140-5767	1	Bracket-Valve
18	138-7163	1	Rod-Lockout	40	68-9410	1	Screw-HHF
19	3272-4	1	Pin-Cotter				

Electrical Assembly

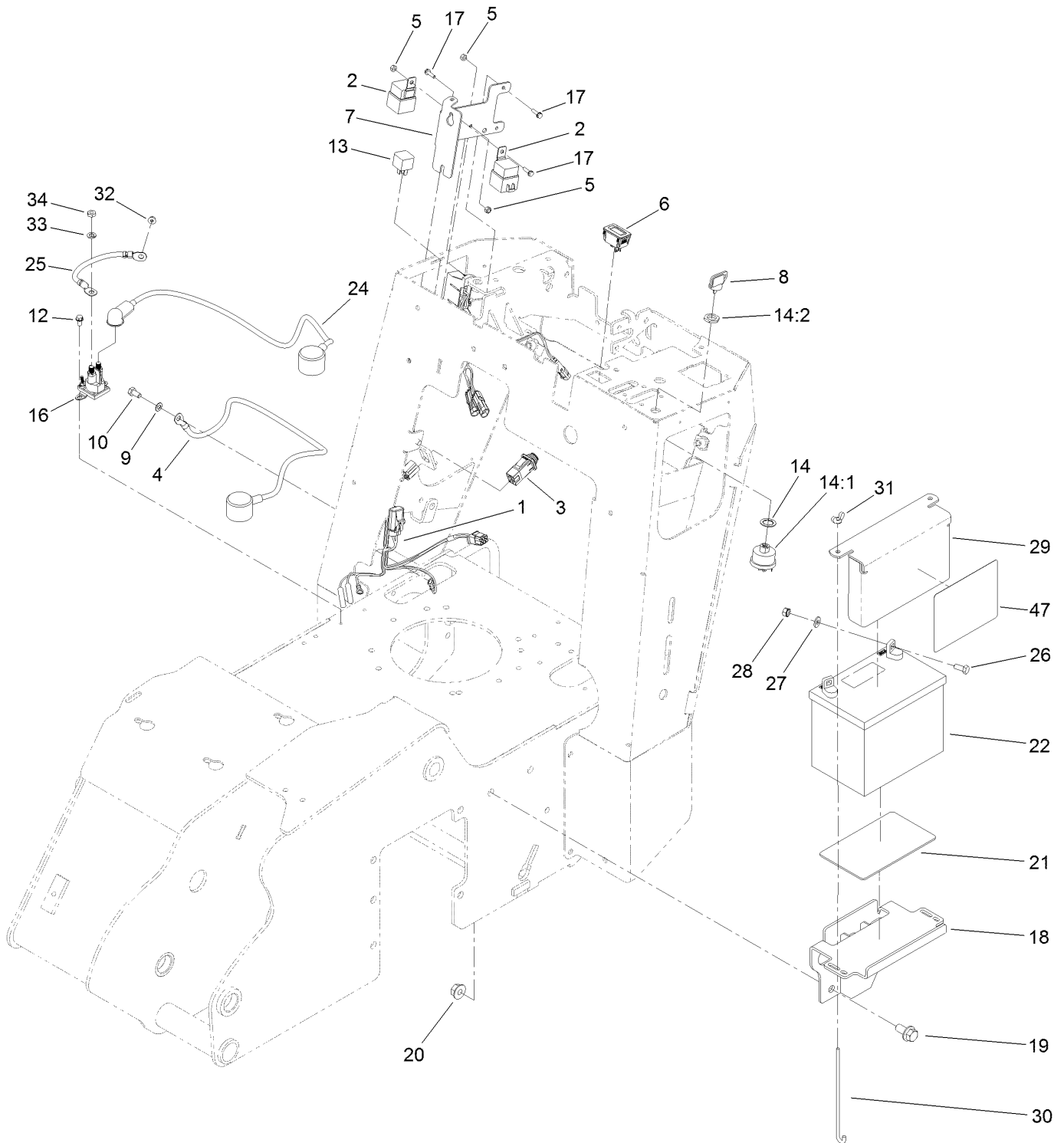

Electrical Assembly (continued)

<i>Ref.</i>	<i>Part Number</i>	<i>Qty.</i>	<i>Description</i>	<i>Ref.</i>	<i>Part Number</i>	<i>Qty.</i>	<i>Description</i>
1	138-7153	1	Harness-Wire	18	138-3114-03	1	Tray-Battery
2	99-7430	1	Relay-Mini	19	3234-6	2	Screw-HHF
3	100-1268	1	Switch-Plunger	20	32128-49	2	Nut-HHF
4	138-3133	1	Cable-Battery, Negative	21	62-4300	1	Pad-Skid, Anti
5	3296-2	4	Nut-Lock, NI	22	104-8162	1	Battery
6	120-2244	1	Hourmeter	24	138-3134	1	Cable-Battery, Positive
7	138-3104-03	1	Bracket-Electrical	25	138-3132	1	Cable-Battery, Positive
8	63-8360	1	Key-Ignition	26	322-3	2	Screw-HH
9	3255-8	1	Washer-Lock	27	3256-2	2	Washer-Flat
10	322-2	1	Screw-HH	28	32149-1	2	Nut-Keps
12	32144-4	2	Screw-HWH	29	115-6621-03	1	Plate-Hold Down, Battery
13	98-7249	1	Relay	30	1-633651	2	Bolt-Holddown
14	88-9830	1	Key Switch ASM	31	32103-22	2	Nut-Wing
14:1	3254-5	1	Washer-Lock	32	33003-00	1	Nut-HF
14:2	218-461	1	Nut-HH	33	3253-4	2	Washer-Lock
16	117-1197	1	Solenoid	34	3220-2	2	Nut-Jam
17	32105-13	4	Screw-HWH	47	137-3882	1	Decal-Service

Wire Harness Assembly No. 138-7153

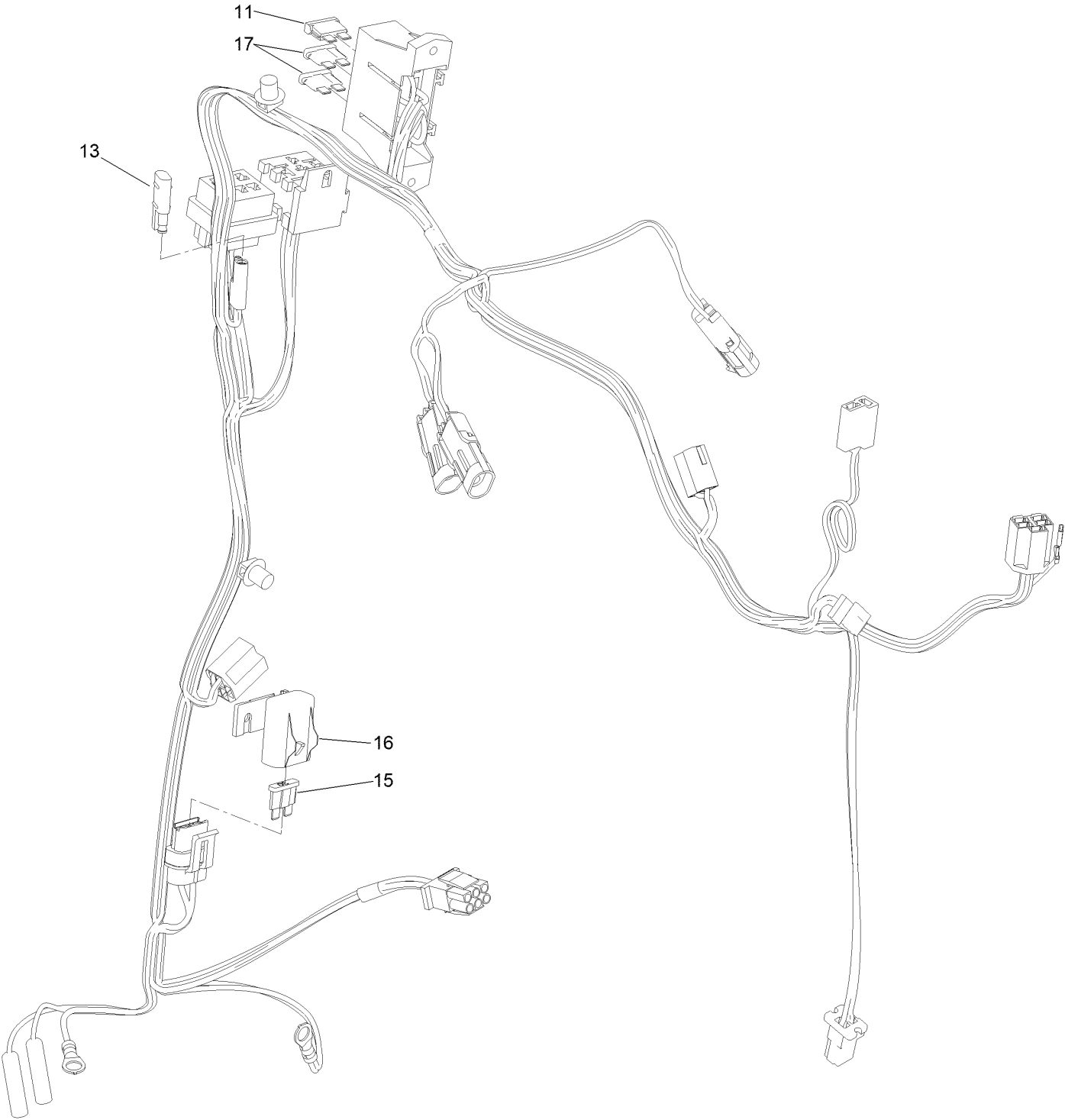

Wire Harness Assembly No. 138-7153 (continued)

<i>Ref.</i>	<i>Part Number</i>	<i>Qty.</i>	<i>Description</i>
11	109355	1	Fuse-Blade, 15 Amp
13	116-0053	1	Cap-Plug
15	109103	1	Fuse-Blade, 30 Amp

<i>Ref.</i>	<i>Part Number</i>	<i>Qty.</i>	<i>Description</i>
16	32180-019	1	Cover-Fuse, Single
17	218-578	2	Fuse-Blade, 10 Amp

Fuel System Assembly

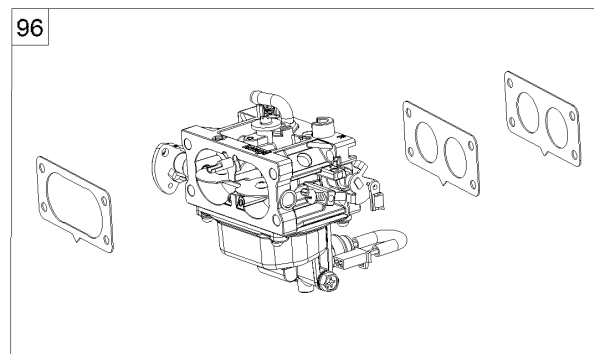
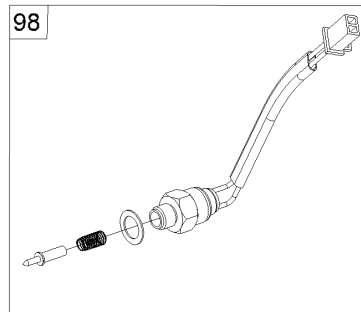
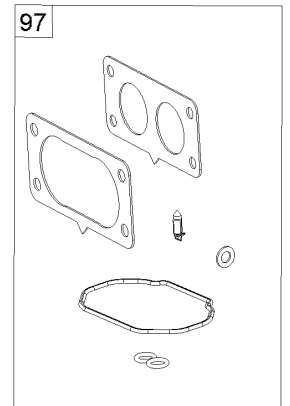
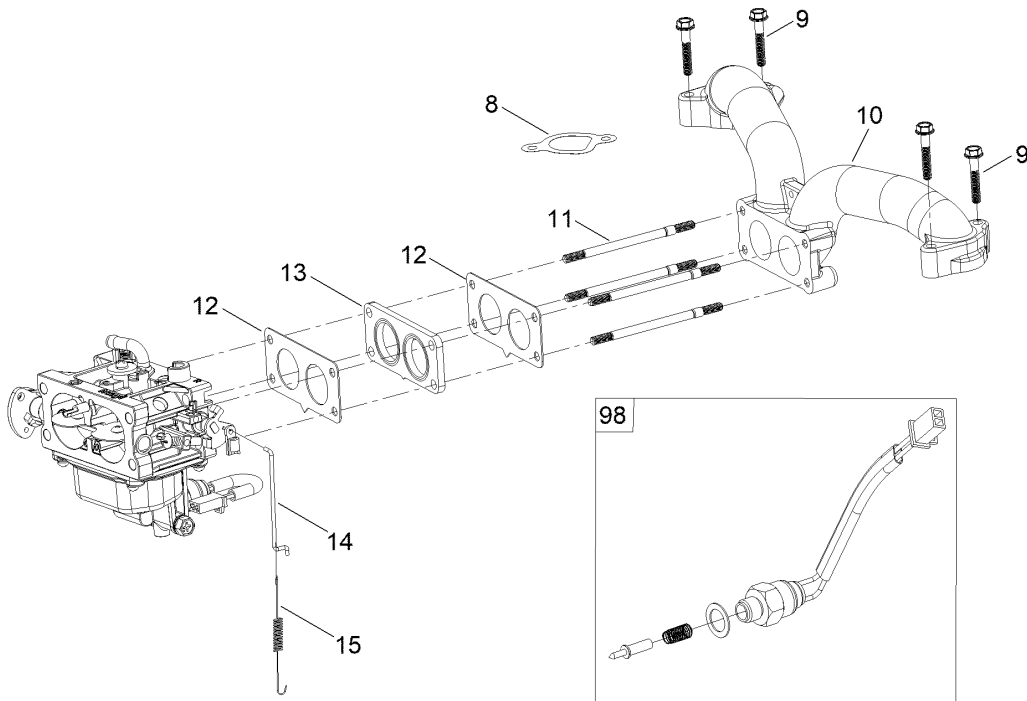
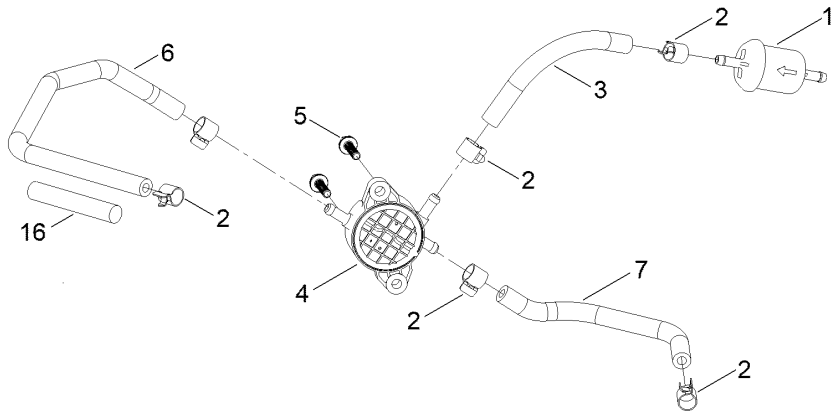

Fuel System Assembly (continued)

<i>Ref.</i>	<i>Part Number</i>	<i>Qty.</i>	<i>Description</i>	<i>Ref.</i>	<i>Part Number</i>	<i>Qty.</i>	<i>Description</i>
1	139-0717	1	Filter-Fuel	12	127-9246	2	Gasket-Carburetor
2	139-0719	6	Clamp-Fuel Hose	13	127-9247	1	Insulator-Carburetor
3	120-4371	1	Line-Fuel	14	133-9963	1	Linkage-Throttle
4	139-0684	1	Pump-Fuel	15	133-9964	1	Spring-Return, Throttle
5	120-4225	2	Screw-HHF	16	127-9355	1	Sleeve-Fuel Line Protector
6	127-9205	1	Hose-Fuel	96	136-7842	1	Carburetor Replacement Kit ASM
7	127-9207	1	Hose-Fuel	97	127-9290	1	Carburetor Repair Kit
8	127-9230	2	Gasket-Intake	98	127-9292	1	Solenoid Kit
9	120-4284	4	Screw-HHF	99	136-7838	1	High Altitude Kit ●
10	127-9244	1	Manifold-Intake				
11	127-9245	4	Stud				

● Not illustrated

Carburetor Assembly

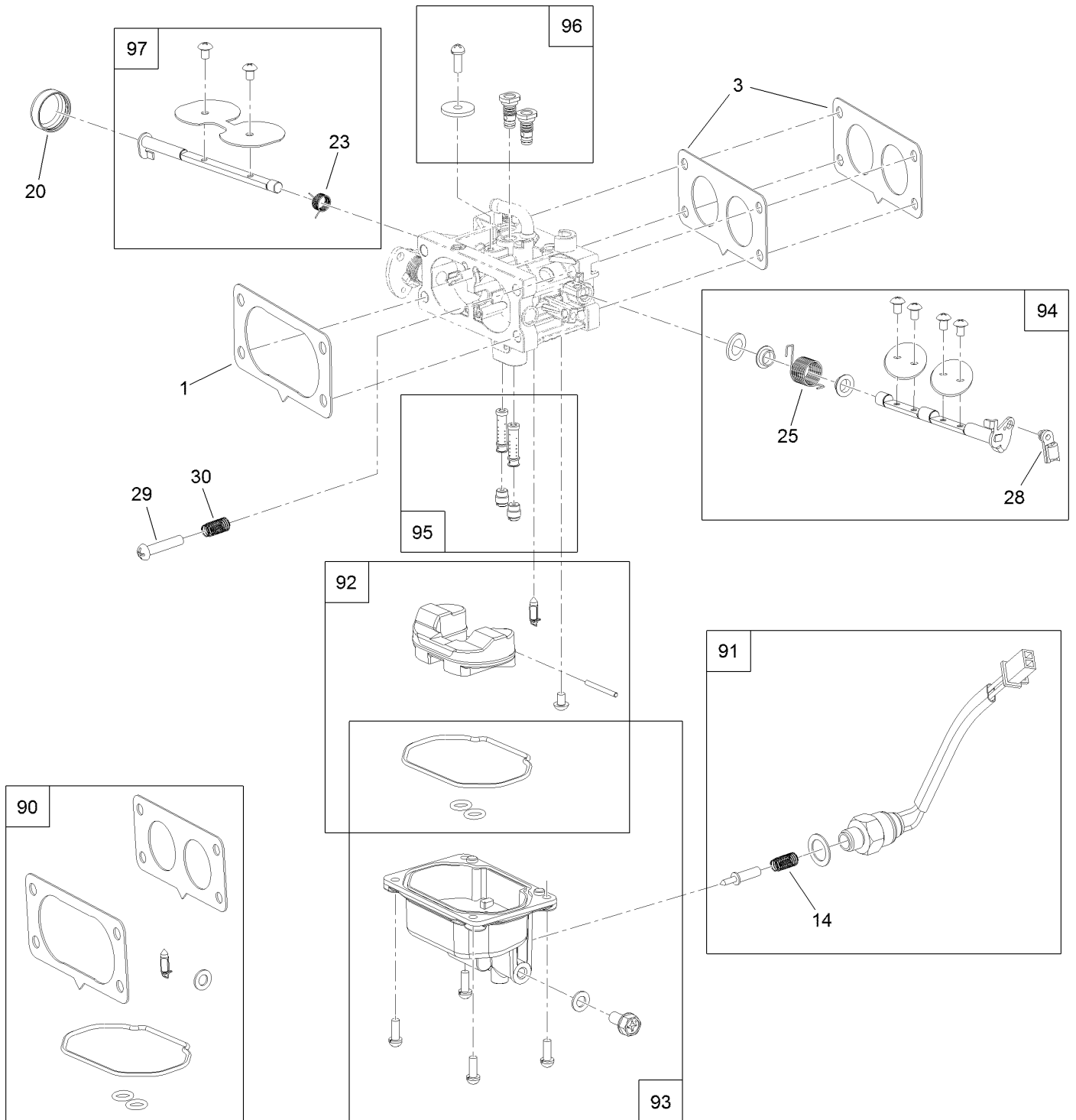

Carburetor Assembly (continued)

<i>Ref.</i>	<i>Part Number</i>	<i>Qty.</i>	<i>Description</i>	<i>Ref.</i>	<i>Part Number</i>	<i>Qty.</i>	<i>Description</i>
1	127-9251	1	Gasket-Carburetor	90	127-9290	1	Carburetor Repair Kit
3	127-9246	2	Gasket-Carburetor	91	127-9292	1	Solenoid Kit
14	127-9319	1	Spring	92	127-9340	1	Float Kit
20	127-9325	1	Cover-Shaft, Choke	93	127-9341	1	Bowl Kit
23	127-9328	1	Spring	94	133-9817	1	Throttle Shaft Kit
25	127-9330	1	Spring	95	136-7846	1	Nozzle And Jet Kit
28	127-9333	1	Clamp-Lock	96	136-7899	1	Idle Jet Kit
29	127-9334	1	Screw-PPH	97	127-9345	1	Choke Shaft Kit
30	127-9335	1	Spring				

Air Intake and Filtration Assembly

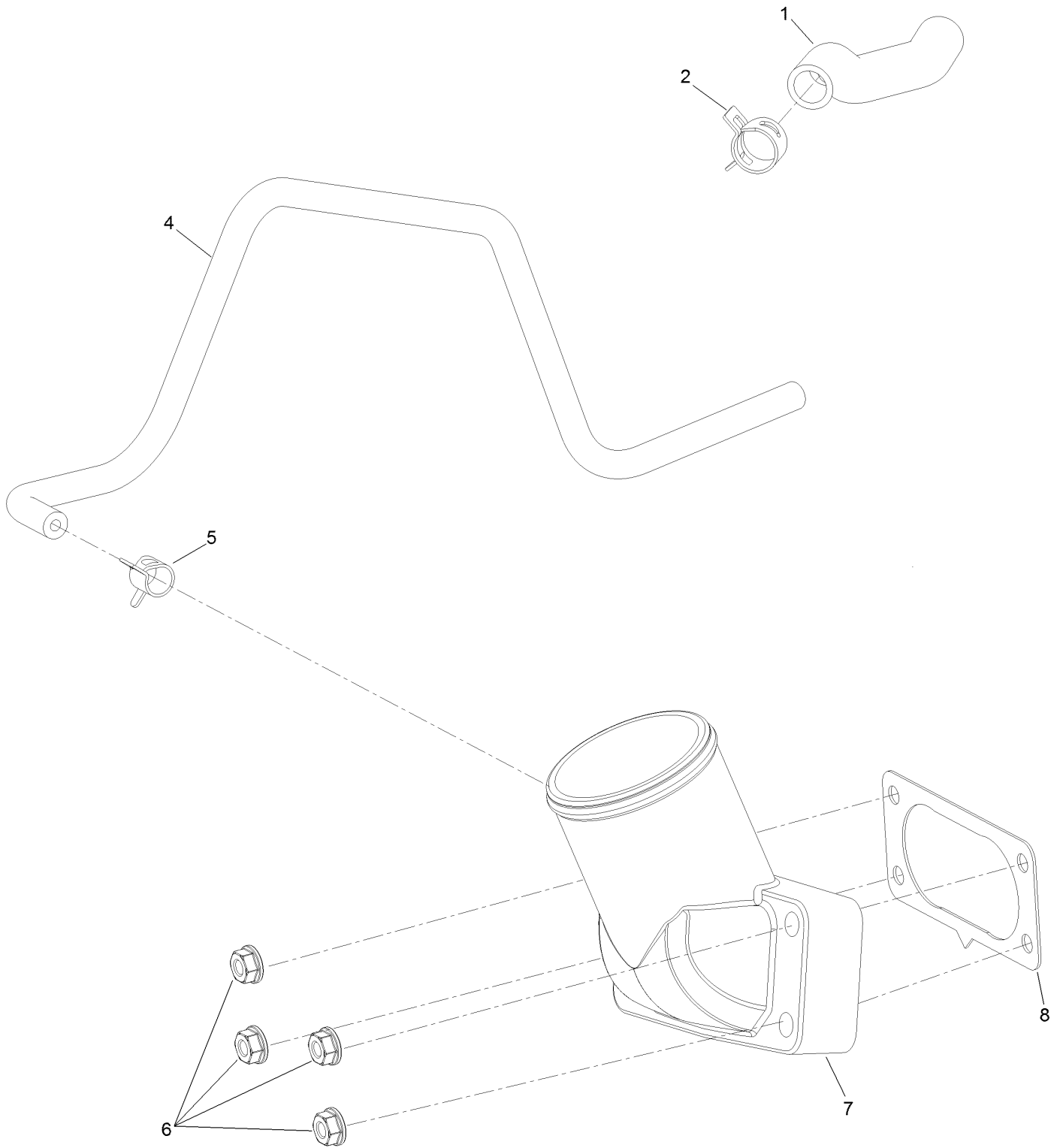

Air Intake and Filtration Assembly (continued)

<i>Ref.</i>	<i>Part Number</i>	<i>Qty.</i>	<i>Description</i>	<i>Ref.</i>	<i>Part Number</i>	<i>Qty.</i>	<i>Description</i>
1	127-9235	1	Tube-Breather	6	120-4236	4	Nut-Flange
2	127-9234	2	Clamp-Hose	7	136-9241	1	Manifold-Intake
4	127-9253	1	Hose-Fuel	8	127-9251	1	Gasket-Carburetor
5	127-9187	1	Clamp-Hose				

Ignition and Cooling Fan Assembly

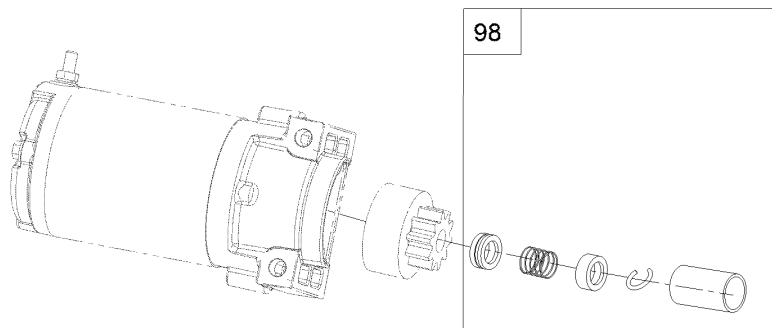
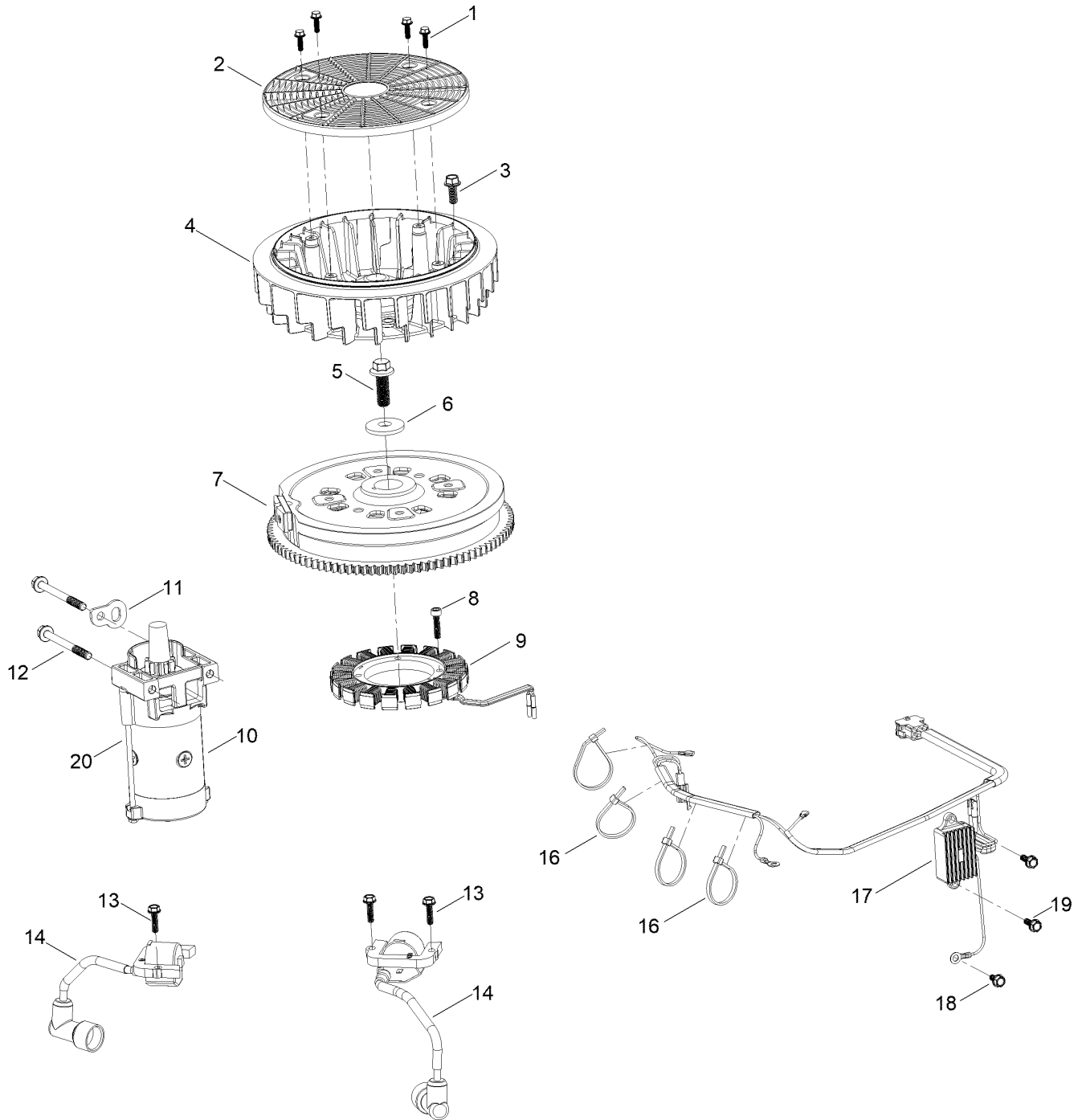

Ignition and Cooling Fan Assembly (continued)

<i>Ref.</i>	<i>Part Number</i>	<i>Qty.</i>	<i>Description</i>	<i>Ref.</i>	<i>Part Number</i>	<i>Qty.</i>	<i>Description</i>
1	127-9197	4	Screw-HWH	12	120-4231	2	Screw-HHF
2	127-9198	1	Screen-Rotating	13	121-0007	4	Bolt-Flange
3	127-9199	4	Screw-HWH	14	139-0720	2	Ignition Coil ASM
4	127-9200	1	Fan-Cooling	16	127-9220	4	Tie-Zip
5	127-9201	1	Screw-HWH	17	136-7879	1	Regulator-Voltage, W/Harness
6	127-9202	1	Washer-Spring	18	120-4216	1	Screw-HHF
7	127-9306	1	Flywheel	19	120-4232	2	Screw-HHF
8	127-9210	4	Screw-HSH	20	133-1562	1	Pinion-Starter
9	136-7876	1	Alternator	98	133-1566	1	Starter Repair Kit
10	136-7880	1	Motor-Starter				
11	127-9208	1	Bracket-Lift				

Crankcase and Crankshaft Assembly

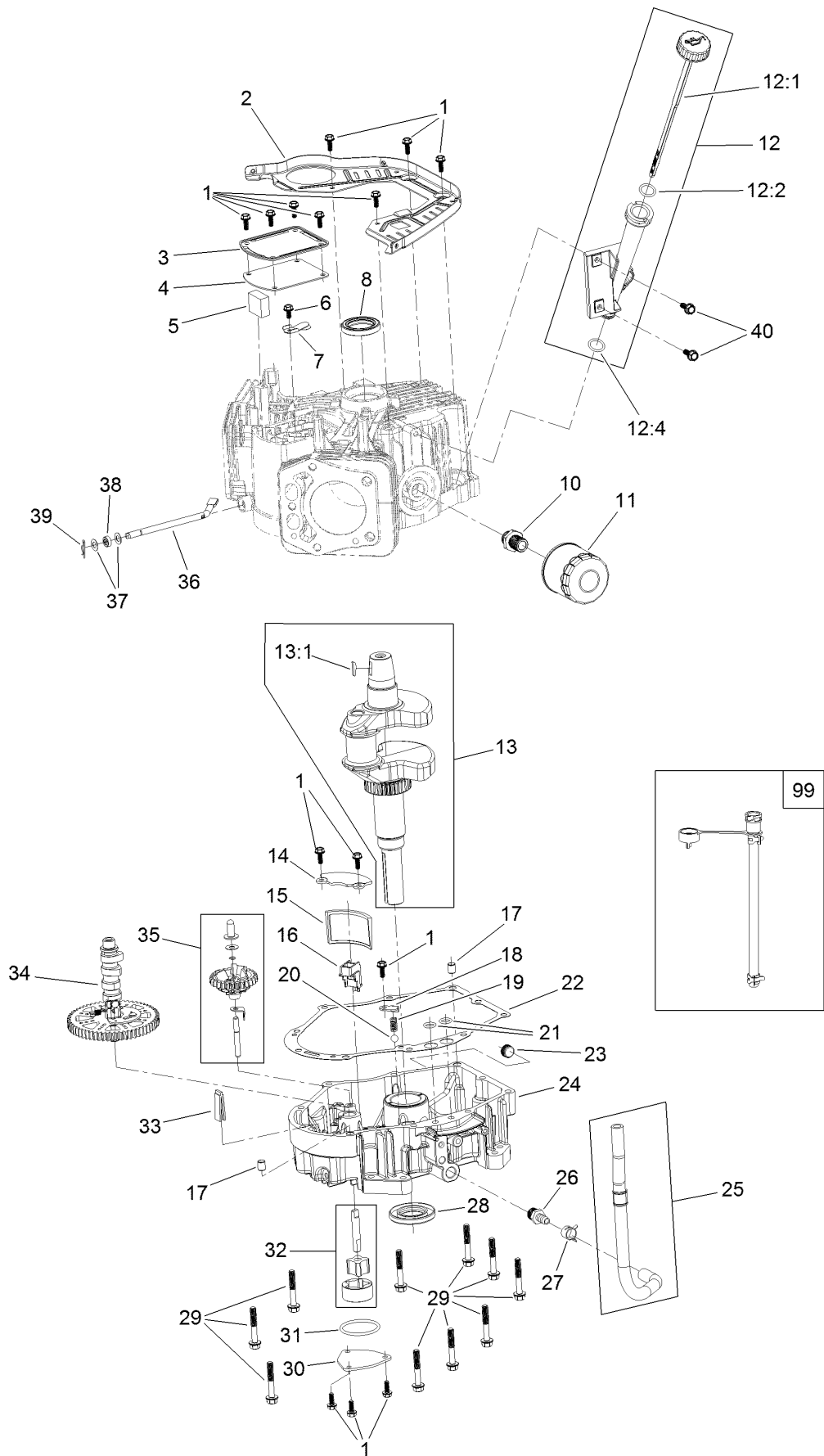

Crankcase and Crankshaft Assembly (continued)

<i>Ref.</i>	<i>Part Number</i>	<i>Qty.</i>	<i>Description</i>	<i>Ref.</i>	<i>Part Number</i>	<i>Qty.</i>	<i>Description</i>
1	120-4232	14	Screw-HHF	20	127-9266	1	Valve-Ball
2	127-9212	1	Baffle	21	120-4262	2	O-Ring
3	127-9213	1	Cover-Breather	22	127-9267	1	Gasket-Cover, Crankcase
4	127-9214	1	Gasket-Breather	23	133-9805	1	Plug-Drain
5	127-9215	1	Filter-Breather	24	133-9806	1	Cover-Crankcase
6	120-4216	1	Screw-HHF	25	127-9293	1	Oil Drain Hose ASM
7	127-9217	1	Valve-Breather	26	127-9275	1	Fitting-Hose
8	120-4267	1	Seal-Oil	27	127-9276	1	Clamp-Hose
10	136-7884	1	Adaptor-Filter, Oil	28	127-9271	1	Seal
11	136-7848	1	Filter-Oil	29	121-0473	10	Screw-HHF
12	127-9218	1	Oil Tube ASM	30	127-9274	1	Cover-Oil Pump
12:1	127-9283	1	Dipstick	31	127-9273	1	O-Ring
12:2	127-9284	1	O-Ring	32	127-9272	1	Oil Pump ASM
12:4	127-9286	1	O-Ring	33	120-4275	1	Deflector-Oil, Rubber
13	127-9255	1	Crankshaft	34	133-1568	1	Camshaft
13:1	120-4320	1	Key-Woodruff	35	136-7882	1	Governor ASM
14	127-9261	1	Cover-Screen, Oil	36	127-9238	1	Shaft-Governor
15	127-9262	1	Screen-Oil	37	120-4258	2	Washer-Plain
16	127-9263	1	Retainer-Screen	38	120-4257	1	Seal-Oil
17	120-4274	2	Pin-Dowel	39	120-4256	1	Pin-Hair
18	127-9264	1	Plate-Retainer	40	120-4232	2	Screw-HHF
19	127-9265	1	Spring	99	144-0976	1	Oil Drain Service Kit

Governor Control Assembly

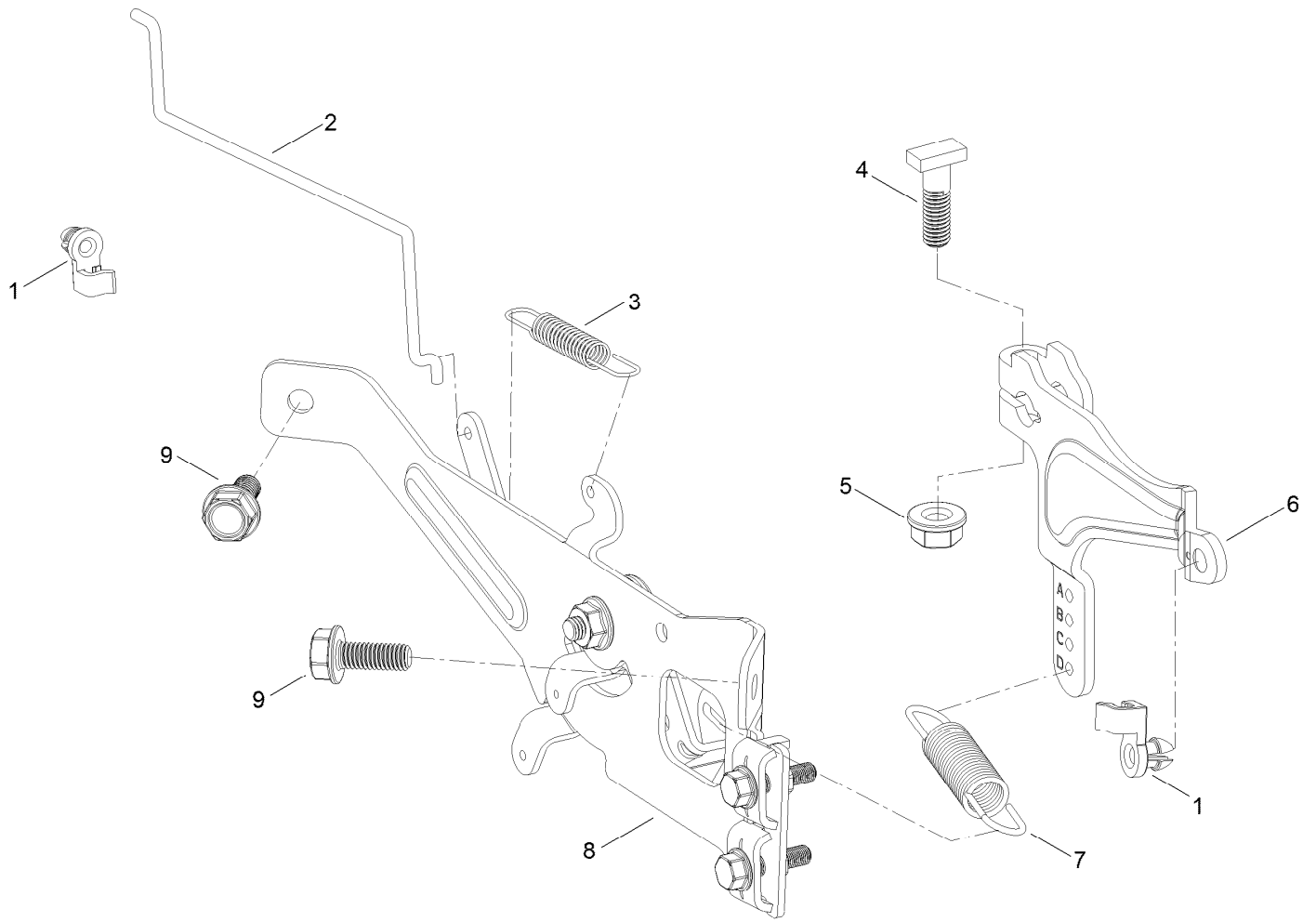

Governor Control Assembly (continued)

<i>Ref.</i>	<i>Part Number</i>	<i>Qty.</i>	<i>Description</i>	<i>Ref.</i>	<i>Part Number</i>	<i>Qty.</i>	<i>Description</i>
1	127-9250	2	Clip-Linkage	6	133-9961	1	Arm-Governor
2	127-9242	1	Linkage-Choke	7	133-9962	1	Spring-Governor
3	127-9241	1	Spring-Governor	8	133-1570	1	Control Plate ASM
4	120-4238	1	Bolt-Arm, Governor	9	120-4232	2	Screw-HHF
5	120-4236	1	Nut-Flange				

Piston and Cylinder Head Assembly

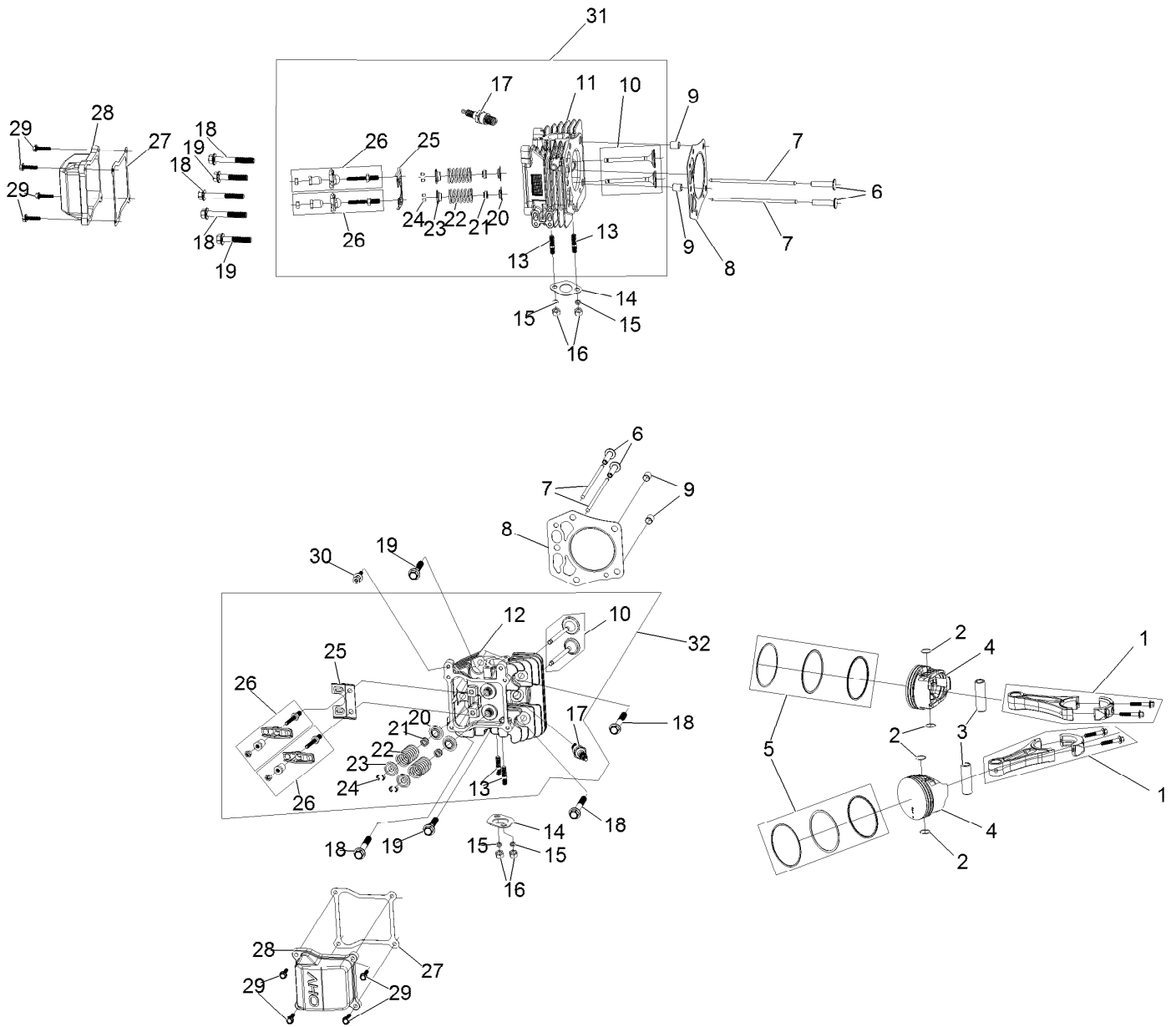

Piston and Cylinder Head Assembly (continued)

<i>Ref.</i>	<i>Part Number</i>	<i>Qty.</i>	<i>Description</i>	<i>Ref.</i>	<i>Part Number</i>	<i>Qty.</i>	<i>Description</i>
1	127-9256	2	Connecting Rod ASM	17	81-3250	2	Spark Plug
2	127-9258	4	Clip-Pin, Piston	18	127-9231	6	Screw-HWH
3	127-9257	2	Pin-Piston	19	127-9232	4	Screw-HWH
4	127-9259	2	Piston	20	120-4303	4	Seat-Spring, Valve
5	127-9260	2	Piston Ring Set	21	120-4304	4	Seal-Stem, Valve
6	127-9224	4	Lifter-Valve	22	120-4305	4	Spring-Valve
7	127-9225	4	Rod-Push	23	120-4306	4	Retainer-Spring, Valve
8	127-9226	2	Gasket-Head, Cylinder	24	120-4307	8	Keeper-Valve
9	127-9227	4	Pin-Dowel	25	127-9233	2	Plate-Guide, Push Rod
10	127-9228	2	Valve Set	26	136-7881	4	Rocker Arm ASM
11	133-9802	1	Head-Cylinder, Right	27	127-9295	2	Gasket-Valve Cover
12	133-9804	1	Head-Cylinder, Left	28	127-9050	2	Cover-Valve
13	121-0464	4	Stud-Exhaust	29	120-4225	8	Screw-HHF
14	120-4317	2	Gasket-Exhaust	30	120-4214	1	Screw-Shoulder, HH
15	127-9279	4	Washer-Lock, Split	31	136-7891	1	Complete Right Head ASM
16	121-0199	4	Nut-HH	32	136-7892	1	Complete Left Head ASM

Blower Housing Assembly

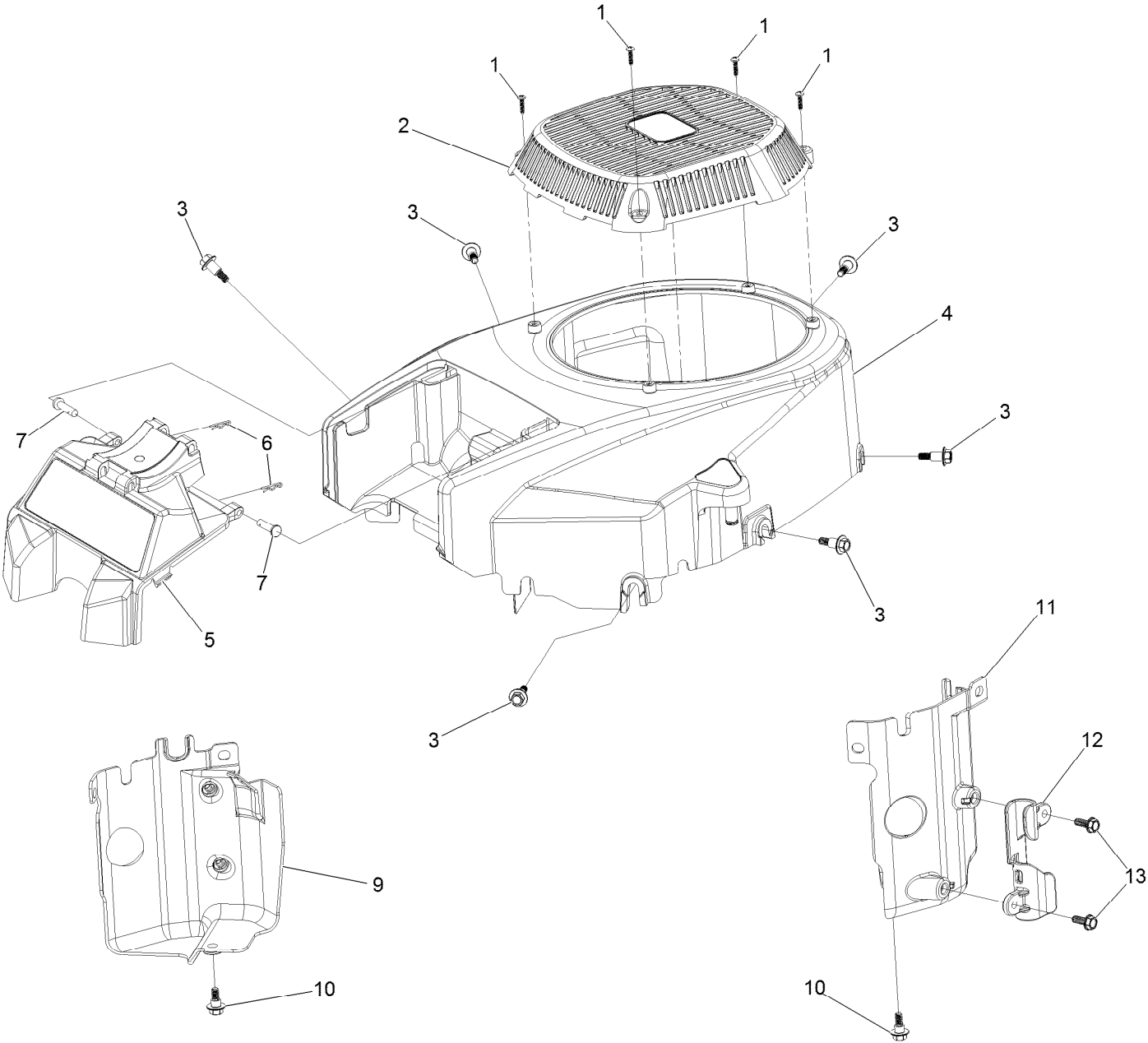

Blower Housing Assembly (continued)

<i>Ref.</i>	<i>Part Number</i>	<i>Qty.</i>	<i>Description</i>	<i>Ref.</i>	<i>Part Number</i>	<i>Qty.</i>	<i>Description</i>
1	133-1571	4	Screw-PPH, Plastic	7	127-9282	2	Pin
2	127-9045	1	Cover-Fan	9	136-7877	1	Baffle-Air, Left
3	127-9196	6	Screw-Shoulder, HWH	10	120-4210	2	Screw-Shoulder, HHF
4	133-1572	1	Shroud-Engine	11	136-7878	1	Baffle-Air, Right
5	136-5585	1	Support-Filter	12	127-9287	1	Cleat-Hose
6	127-9280	2	Pin-Hair	13	120-4232	2	Screw-HHF

Gasket and Seal Kit

1

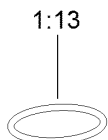
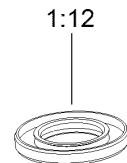
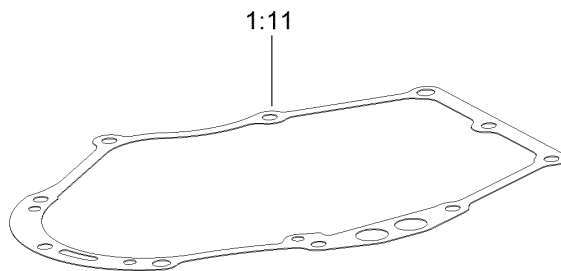
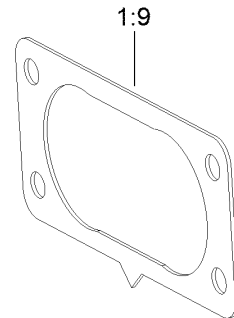
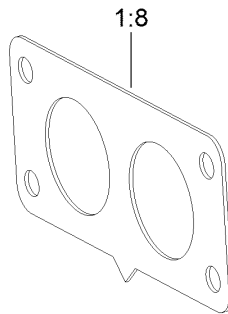
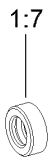
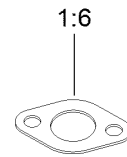
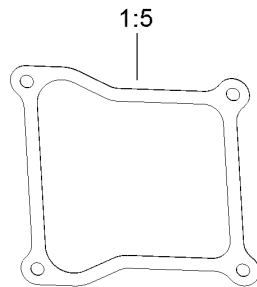
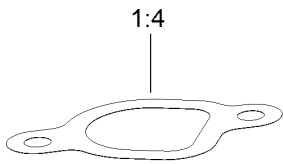
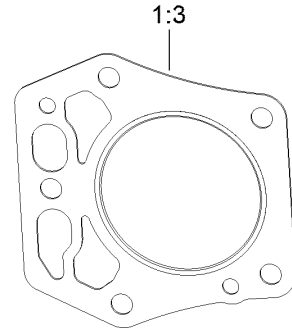
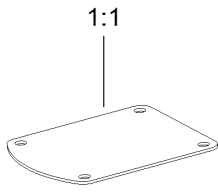

Gasket and Seal Kit (continued)

<i>Ref.</i>	<i>Part Number</i>	<i>Qty.</i>	<i>Description</i>	<i>Ref.</i>	<i>Part Number</i>	<i>Qty.</i>	<i>Description</i>
1	127-9296	1	Gasket And Seal Kit	1:8	127-9246	2	Gasket-Carburetor
1:1	127-9214	1	Gasket-Breather	1:9	127-9251	1	Gasket-Carburetor
1:2	120-4267	1	Seal-Oil	1:10	120-4262	2	O-Ring
1:3	127-9226	2	Gasket-Head, Cylinder	1:11	127-9267	1	Gasket-Cover, Crankcase
1:4	127-9230	2	Gasket-Intake	1:12	127-9271	1	Seal
1:5	127-9295	2	Gasket-Valve Cover	1:13	127-9273	1	O-Ring
1:6	120-4317	2	Gasket-Exhaust	1:14	127-9284	1	O-Ring
1:7	120-4257	1	Seal-Oil	1:15	127-9286	1	O-Ring

Attachments and Accessories

For 22983 TRX-250 Trencher

Product Name	Model/Part
Crumber Kit	22477
24in Trencher Boom	22975
36in Trencher Boom	22976
48in Trencher Boom	22977
24in X 4in Soil Chain.....	22480
24in X 6in Soil Chain.....	22483
36in X 4in Soil Chain.....	22486
36in X 6in Soil Chain.....	22490
24in X 4in Combination Chain	22481
Spark Arrestor Screen	94-8157
24in X 6in Combination Chain	22484
36in X 4in Combination Chain	22487
36in X 6in Combination Chain	22491
24in X 4in Rock Tooth Chain.....	22482
24in X 6in Rock Tooth Chain.....	22485
36in X 4in Rock Tooth Chain.....	22488
36in X 6in Rock Tooth Chain.....	22489
48in x 4in Soil Chain	22492
48in x 4in Combination Chain	22493
48in x 6in Soil Chain	22494
48in x 6in Combination Chain	22495
24in X 4in Bullet Chain.....	22496
24in X 6in Bullet Chain.....	22497
36in X 4in Bullet Chain.....	22498
36in X 6in Bullet Chain.....	22499
Bore Drive Attachment.....	22978
Backfill Blade	22980
8in Chain Conversion Kit for 36in Soil Chain.....	117-3480

Notes:



Count on it.