



**Count on it.**

**Operator's Manual**

**Reelmaster® 3550 Traction Unit**

Model No. 03910—Serial No. 40000000 and Up



**⚠ WARNING**

**CALIFORNIA  
Proposition 65 Warning**

**Diesel engine exhaust and some of its constituents are known to the State of California to cause cancer, birth defects, and other reproductive harm.**

Model No. \_\_\_\_\_

Serial No. \_\_\_\_\_

This manual identifies potential hazards and has safety messages identified by the safety-alert symbol (Figure 2), which signals a hazard that may cause serious injury or death if you do not follow the recommended precautions.



Figure 2

g000502

1. Safety-alert symbol

# Introduction

This machine is a ride-on, reel-blade lawnmower intended to be used by professional, hired operators in commercial applications. It is primarily designed for cutting grass on well-maintained lawns in parks, golf courses, sports fields, and on commercial grounds. It is not designed for cutting brush, mowing grass and other growth alongside highways, or for agricultural uses.

Read this information carefully to learn how to operate and maintain your product properly and to avoid injury and product damage. You are responsible for operating the product properly and safely.

You may contact Toro directly at [www.Toro.com](http://www.Toro.com) for product and accessory information, help finding a dealer, or to register your product.

Whenever you need service, genuine Toro parts, or additional information, contact an Authorized Service Dealer or Toro Customer Service and have the model and serial numbers of your product ready. Figure 1 identifies the location of the model and serial numbers on the product. Write the numbers in the space provided.

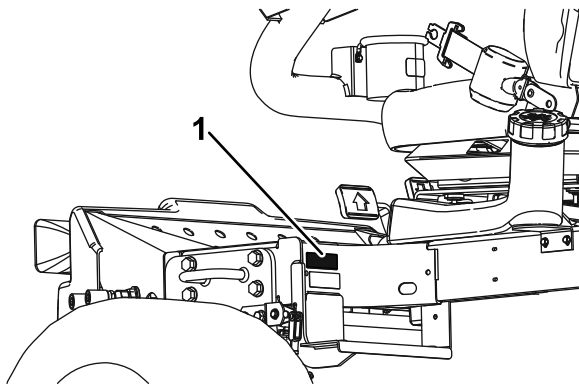

g019979

g019979

Figure 1

1. Model and serial number location

# Contents

Safety .....	4	Inspecting the Fuel Lines and Connections.....	39
General Safety .....	4	Draining the Water Separator .....	39
Safety and Instructional Decals .....	4	Changing the Fuel Filter Canister.....	39
Setup .....	10	Bleeding Air from the Injectors .....	39
1 Installing the Cutting Units.....	11	Electrical System Maintenance .....	40
2 Adjusting the Turf Compensation Spring .....	13	Electrical System Safety .....	40
3 Installing the CE Decal.....	13	Servicing the Battery.....	40
4 Installing the Hood Latch (CE Only).....	14	Checking the Fuses .....	41
5 Using the Cutting Unit Kickstand .....	15	Drive System Maintenance .....	41
Product Overview .....	16	Adjusting the Traction Drive for Neutral .....	41
Controls .....	16	Cooling System Maintenance .....	42
Specifications .....	18	Cooling System Safety .....	42
Attachments/Accessories .....	18	Cleaning the Engine Cooling System .....	42
Operation .....	19	Brake Maintenance .....	43
Before Operation Safety .....	19	Adjusting the Parking Brake.....	43
Checking the Engine-Oil Level.....	19	Servicing the Parking Brakes.....	43
Filling the Fuel Tank.....	20	Belt Maintenance .....	47
Checking the Cooling System.....	21	Servicing the Engine Belts .....	47
Checking the Hydraulic System .....	21	Controls System Maintenance .....	48
Checking the Reel-to-Bedknife Contact .....	22	Adjusting the Throttle.....	48
Checking the Tire Pressure.....	22	Hydraulic System Maintenance .....	49
Torquing the Wheel Nuts.....	23	Hydraulic System Safety.....	49
Checking the Parking Brake .....	23	Changing the Hydraulic Filter.....	49
Positioning the Seat.....	23	Changing the Hydraulic Fluid.....	49
During Operation Safety .....	24	Checking the Hydraulic Lines and Hoses.....	50
Starting and Shutting Off the Engine .....	25	Cutting Unit System Maintenance .....	50
Setting the Reel Speed .....	26	Cutting Unit Safety.....	50
Adjusting the Lift Arm Counterbalance .....	26	Using the Optional Gauge Bar .....	50
Bleeding the Fuel System .....	27	Backlapping the Cutting Units.....	51
Understanding the Diagnostic Light .....	28	Storage .....	52
Understanding the Diagnostic ACE Display .....	28	Storing the Battery .....	52
Checking the Interlock Switches .....	29	Preparing the Machine for Seasonal Storage .....	52
After Operation Safety .....	30		
Identifying the Tie-Down Points .....	30		
Hauling the Machine .....	31		
Towing the Machine.....	31		
Operating Tips .....	31		
Maintenance .....	32		
Recommended Maintenance Schedule(s) .....	32		
Daily Maintenance Checklist.....	33		
Service Interval Chart .....	34		
Pre-Maintenance Procedures .....	34		
Pre-Maintenance Safety .....	34		
Removing the Hood .....	34		
Removing the Battery Cover .....	35		
Lubrication .....	36		
Greasing the Bearings and Bushings .....	36		
Engine Maintenance .....	37		
Engine Safety .....	37		
Servicing the Air Cleaner .....	37		
Changing the Engine Oil and Filter.....	38		
Fuel System Maintenance .....	39		
Servicing the Fuel Tank.....	39		

# Safety

This machine has been designed in accordance with EN ISO 5395:2013 (when appropriate decals are applied) and ANSI B71.4-2012.

## General Safety

This product is capable of amputating hands and feet and of throwing objects. Always follow all safety instructions to avoid serious personal injury.

Using this product for purposes other than its intended use could prove dangerous to you and bystanders.

- Read and understand the contents of this *Operator's Manual* before starting the engine.
- Do not put your hands or feet near moving components of the machine.
- Do not operate the machine without all guards and other safety protective devices in place and working on the machine.

- Keep clear of any discharge opening. Keep bystanders and pets a safe distance away from the machine.
- Keep children out of the operating area. Never allow children to operate the machine.
- Stop the machine and shut off the engine before servicing, fueling, or unclogging the machine.

Improperly using or maintaining this machine can result in injury. To reduce the potential for injury, comply with these safety instructions and always pay attention to the safety-alert symbol, which means Caution, Warning, or Danger—personal safety instruction. Failure to comply with these instructions may result in personal injury or death.

You can find additional safety information where needed throughout this *Operator's Manual*.

## Safety and Instructional Decals



Safety decals and instructions are easily visible to the operator and are located near any area of potential danger. Replace any decal that is damaged or missing.

**CALIFORNIA SPARK ARRESTER WARNING**  
 Operation of this equipment may create sparks that can start fires around dry vegetation. A spark arrester may be required. The operator should contact local fire agencies for laws or regulations relating to fire prevention requirements. 117-2718

117-2718

decal117-2718

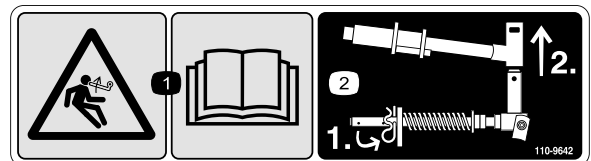

110-9642

decal110-9642

1. Stored energy hazard—read the *Operator's Manual*.
2. Move the cotter pin to the hole closest to the rod bracket and then remove the lift arm and pivot yoke.

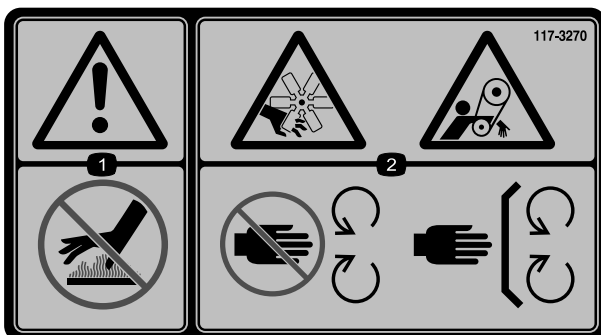

117-3270

decal117-3270

1. Warning—do not touch the hot surface.
2. Cutting/dismemberment hazard, hand; entanglement hazard, belt—stay away from moving parts, keep all guards and shields in place.

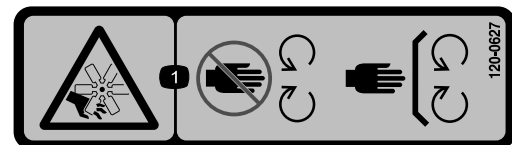

120-0627

decal120-0627

1. Cutting/dismemberment hazard, fan—stay away from moving parts, keep all guards and shields in place.

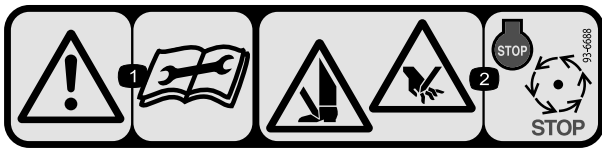

decal93-6688

93-6688

1. Warning—read the *Operator's Manual* before performing maintenance.
2. Cutting hazard of hand or foot—shut off the engine and wait for all moving parts to stop.

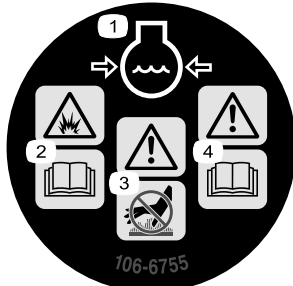

decal106-6755

106-6755

1. Engine coolant under pressure.
2. Explosion hazard—read the *Operator's Manual*.
3. Warning—do not touch the hot surface.
4. Warning—read the *Operator's Manual*.



decal93-7276

93-7276

1. Explosion hazard—wear eye protection.
2. Caustic liquid/chemical burn hazard—to perform first aid, flush with water.
3. Fire hazard—no fire, open flames, or smoking.
4. Poison hazard—keep children a safe distance away from the battery.

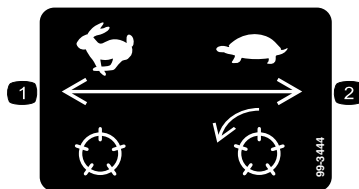

decal99-3444

99-3444

1. Transport speed
2. Mow speed

### REELMASTER 3550-D QUICK REFERENCE AID

CHECK/SERVICE (DAILY)

1. OIL LEVEL ENGINE
2. ENGINE OIL DRAIN (3/4" OR 19mm SOCKET)
3. OIL LEVEL HYDRAULIC TANK
4. COOLANT LEVEL RADIATOR
5. FUEL/WATER SEPARATOR
6. AIR CLEANER
7. RADIATOR SCREEN
8. PARKING BRAKE
9. TIRE PRESSURE (12 psi)
10. BATTERY
11. BELTS (FAN, ALTERNATOR, HYDRAULIC PUMP)
12. REEL SPEED & BACKLAP CONTROL

GREASING - SEE OPERATOR'S MANUAL

#### FLUID SPECIFICATIONS/CHANGE INTERVALS

SEE OPERATOR'S MANUAL FOR INITIAL CHANGES	FLUID TYPE	CAPACITY	CHANGE INTERVAL FLUID	CHANGE INTERVAL FILTER	FILTER PART NO.
A. ENGINE OIL	SAE 15W-40 CH4	4.0 QTS*	150 HRS.	150 HRS.	108-3841
B. HYD. CIRCUIT OIL	ISO VG 46/68	6 GAL.*	400 HRS.	200 HRS.	85-3010
C. AIR CLEANER			200 HRS.		108-3811
D. WATER SEPARATOR			400 HRS.		110-9049
E. FUEL TANK	NO. 2-DIESEL	7.5 GALS.	DRAIN AND FLUSH, 2 YRS.		
F. COOLANT	90/10 ETHYLENE GLYCOL/WATER	6 QTS.	DRAIN AND FLUSH, 2 YRS.		

\*INCLUDING FILTER

120-2102

120-2102

1. Read the *Operator's Manual*



decalbatterysymbols

### Battery Symbols

Some or all of these symbols are on your battery

1. Explosion hazard
2. No fire, open flame, or smoking
3. Caustic liquid/chemical burn hazard
4. Wear eye protection.
5. Read the *Operator's Manual*.
6. Keep bystanders a safe distance away from the battery.
7. Wear eye protection; explosive gases can cause blindness and other injuries.
8. Battery acid can cause blindness or severe burns.
9. Flush eyes immediately with water and get medical help fast.
10. Contains lead; do not discard

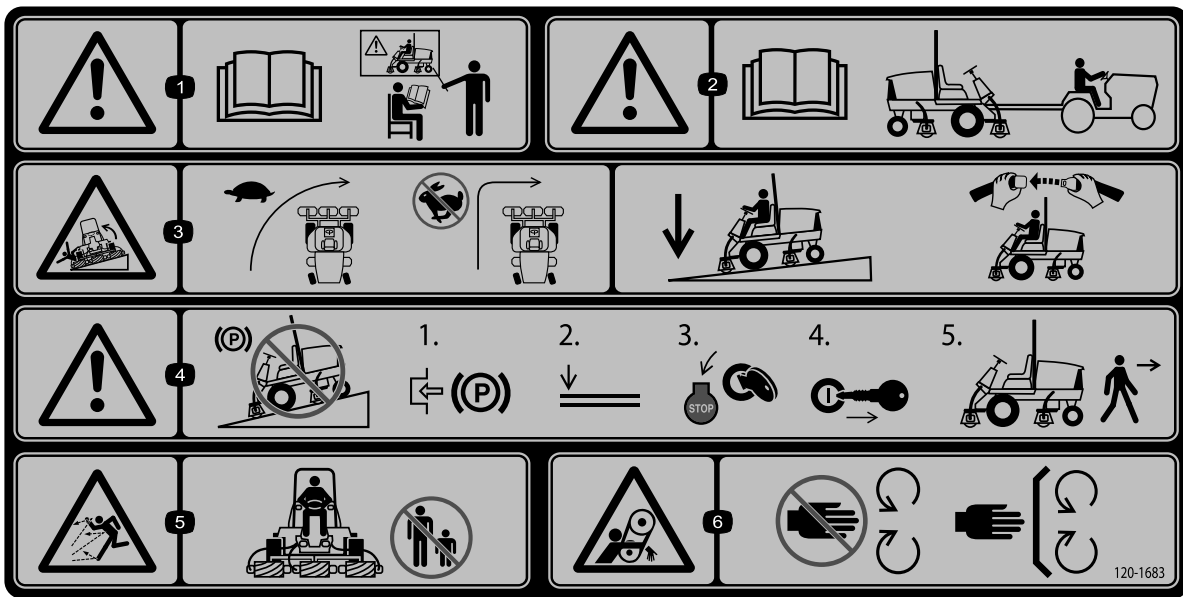

decal120-1683

### 120-1683

1. Warning—read the *Operator's Manual*; all operators should be trained before operating the machine.
2. Warning—read the *Operator's Manual* before towing the machine.
3. Tipping hazard—drive slowly when turning; do not turn sharply while traveling fast; lower the cutting units when driving down slopes; use a rollover protection system and wear the seatbelt.
4. Warning—do not park the machine on slopes; engage the parking brake, lower the cutting units, shut off the engine, and remove the key before leaving the machine.
5. Thrown object hazard—keep bystanders away.
6. Entanglement hazard, belt—stay away from moving parts; keep all guards and shields in place.

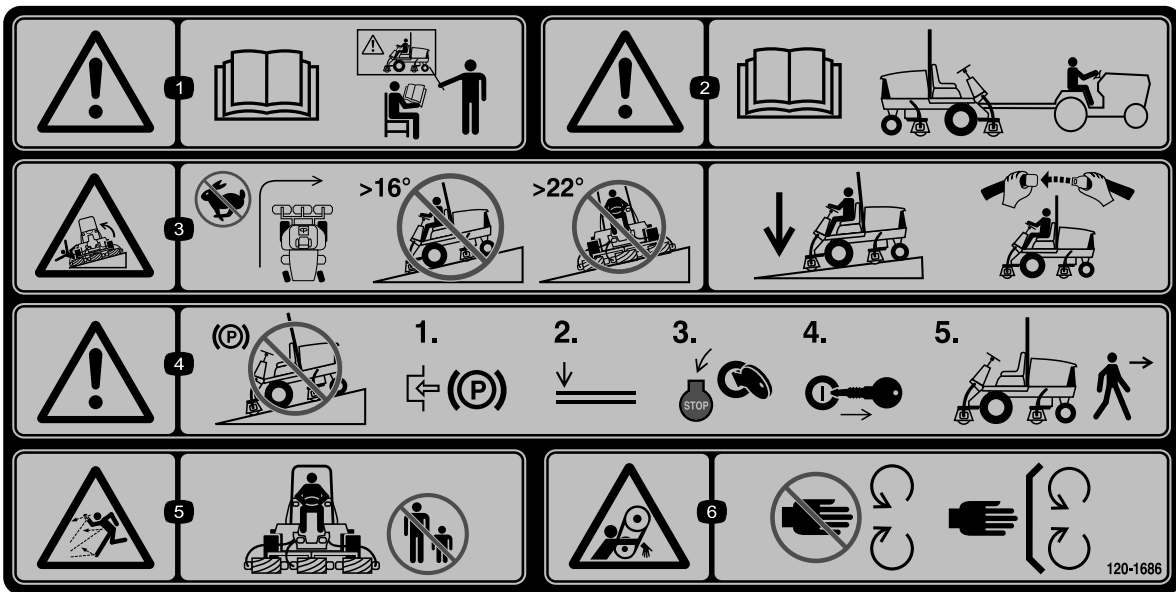

decal120-1686

### 120-1686

(Affix over Part No. 120-1683 for CE)

**Note:** This machine complies with the industry standard stability test in the static lateral and longitudinal tests with the maximum recommended slope indicated on the decal. Review the instructions for operating the machine on slopes in the *Operator's Manual* as well as the conditions in which you would operate the machine to determine whether you can operate the machine in the conditions on that day and at that site. Changes in the terrain can result in a change in slope operation for the machine. If possible, keep the cutting units lowered to the ground while operating the machine on slopes. Raising the cutting units while operating on slopes can cause the machine to become unstable.

1. Warning—read the *Operator's Manual*; do not operate this machine unless you are trained.
2. Warning—read the *Operator's Manual* before towing the machine.
3. Tipping hazard—do not turn at high speeds; do not drive up or down slopes greater than 16°; do not drive across slopes greater than 22°; lower the cutting units when driving down slopes; use a roll-over protection system and wear the seatbelt.
4. Warning—do not park the machine on slopes; engage the parking brake, lower the cutting units, shut off the engine, and remove the ignition key before leaving the machine.
5. Thrown object hazard—keep bystanders away.
6. Entanglement hazard, belt—stay away from moving parts; keep all guards and shields in place.

HOC

mm / inches

38.1 / 1.500	2	2	2	3	3	3	3	3	3
36.5 / 1.438	2	2	2	3	3	3	3	3	3
34.9 / 1.375	2	2	3	3	3	3	3	3	3
33.3 / 1.313	2	2	3	3	3	3	3	3	3
31.8 / 1.250	2	2	3	3	3	3	3	3	4
30.2 / 1.188	2	3	3	3	3	3	3	4	4
28.6 / 1.125	2	3	3	3	3	3	4	4	4
27.0 / 1.063	2	3	3	3	3	3	4	4	4
25.4 / 1.000	3	3	3	3	3	4	4	4	4
23.8 / 0.938	3	3	3	3	3	4	4	4	4
22.2 / 0.875	3	3	3	3	4	4	4	4	5
20.6 / 0.813	3	3	3	4	4	4	4	5	5
19.5 / 0.750	3	3	3	4	4	4	5	5	6
17.5 / 0.688	3	3	4	4	4	5	5	6	6
15.9 / 0.625	3	4	4	4	5	5	6	6	7
14.3 / 0.563	4	4	4	5	5	6	6	7	8
12.7 / 0.500	4	4	5	6	6	7	7	8	9
11.1 / 0.438	4	5	6	7	7	8	8	9	
9.5 / 0.375	5	6	7	8	8	9	9		
7.9 / 0.313	6	7	8	9					
6.3 / 0.25	7	8	9						

4.8	5.6	6.4	7.2	8.1	8.9	9.7	10.5	11.3	km
3.0	3.5	4.0	4.5	5.0	5.5	6.0	6.5	7.0	mph



5" (127mm)  
REEL SPEED  
CHART

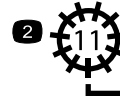

HOC

mm / inches

19.5 / 0.750	2	3	3	3	3	3	4	4	4
17.5 / 0.688	3	3	3	3	3	4	4	4	4
15.9 / 0.625	3	3	3	3	4	4	4	4	5
14.3 / 0.563	3	3	3	4	4	4	4	5	5
12.7 / 0.500	3	3	4	4	4	5	6	6	6
11.1 / 0.438	3	4	4	4	5	6	7	7	7
9.5 / 0.375	4	4	5	5	6	7	8	8	8
7.9 / 0.313	4	5	5	6	7	8	9	9	9
6.4 / 0.250	5	5	6	7	8	9			

4.8	5.6	6.4	7.2	8.1	8.9	9.7	10.5	11.3	km
3.0	3.5	4.0	4.5	5.0	5.5	6.0	6.5	7.0	mph



121-7884

decal121-7884

1. 8-blade reel adjustment
2. 11-blade reel adjustment
3. Read the *Operator's Manual* for information on adjusting the reel.



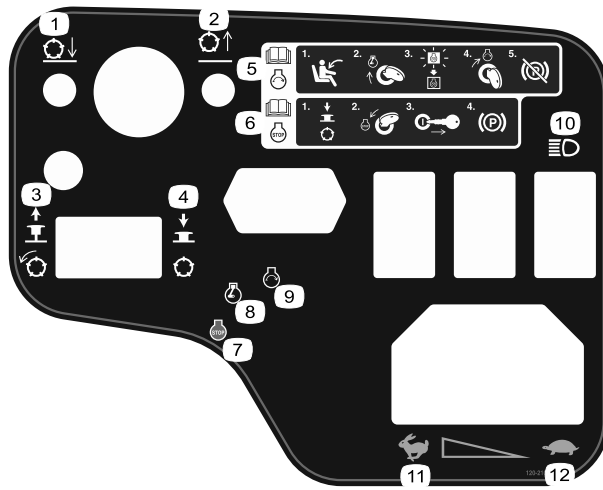

decal120-2105

### 120-2105

- |                                                                                                                                                           |                                                                                                                                                                                                                                                                                                                                                                                                                                                                                                                                                                                                |                                                                          |
|-----------------------------------------------------------------------------------------------------------------------------------------------------------|------------------------------------------------------------------------------------------------------------------------------------------------------------------------------------------------------------------------------------------------------------------------------------------------------------------------------------------------------------------------------------------------------------------------------------------------------------------------------------------------------------------------------------------------------------------------------------------------|--------------------------------------------------------------------------|
| <p>1. Lower the reels.</p> <p>2. Raise the reels.</p> <p>3. Pull the knob out to engage the reels.</p> <p>4. Push the knob in to disengage the reels.</p> | <p>5. Read the <i>Operator's Manual</i> for information on starting the engine—1) Sit in the operator's position; 2) Turn the key to the engine—preheat position; 3) Wait until the electrical preheat light turns off; 4) Turn the key to the engine—start position; 5) Disengage the parking brake.</p> <p>6. Read the <i>Operator's Manual</i> for information on shutting off the engine—1) Disengage the reels; 2) Turn the key to the engine—shut off position; 3) Remove the key from the ignition; 4) Engage the parking brake.</p> <p>7. Engine—shut off</p> <p>8. Engine—preheat</p> | <p>9. Engine—start</p> <p>10. Lights</p> <p>11. Fast</p> <p>12. Slow</p> |
|-----------------------------------------------------------------------------------------------------------------------------------------------------------|------------------------------------------------------------------------------------------------------------------------------------------------------------------------------------------------------------------------------------------------------------------------------------------------------------------------------------------------------------------------------------------------------------------------------------------------------------------------------------------------------------------------------------------------------------------------------------------------|--------------------------------------------------------------------------|

# Setup

## Loose Parts

Use the chart below to verify that all parts have been shipped.

Procedure	Description	Qty.	Use
<b>1</b>	No parts required	–	Install the cutting units.
<b>2</b>	No parts required	–	Adjust the turf compensation spring.
<b>3</b>	Warning decal (120-1686)	1	Install the CE decal, if required.
<b>4</b>	Lock bracket Rivet Washer Screw (1/4 x 2 inches) Locknut (1/4 inch)	1 2 1 1 1	Install the hood latch (CE only).
<b>5</b>	Cutting unit kickstand	1	Use the cutting unit kickstand.

## Media and Additional Parts

Description	Qty.	Use
Ignition keys	2	Start the engine.
Operator's Manual Engine operator's manual	1 1	Read the manuals before operating the machine.
Operator training material	1	Review the training material before operating the machine.
Cutting performance paper	1	Use the paper for adjusting the cutting unit reel-to-bedknife contact.
Shim	1	Use the shim for adjusting the cutting unit reel-to-bedknife contact.

**Note:** Determine the left and right sides of the machine from the normal operating position.

# 1

## Installing the Cutting Units

No Parts Required

### Procedure

1. Park the machine on a level surface, engage the parking brake, shut off the engine, and remove the key.
2. Remove the reel motors from the shipping brackets.
3. Remove and discard the shipping brackets.
4. Remove the cutting units from the cartons. Assemble and adjust as described in the cutting unit *Operator's Manual*.
5. Make sure that the counterweight (Figure 3) is installed to the proper end of the cutting unit as described in the cutting unit *Operator's Manual*.

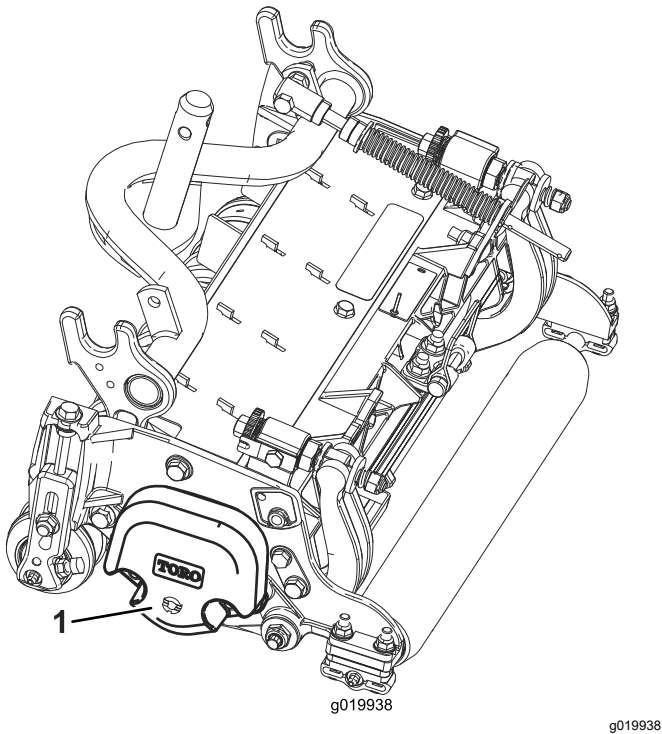

Figure 3

1. Counterweight

6. All the cutting units are shipped with the turf compensation spring mounted to the right side of the cutting unit. The turf compensation spring must be mounted to the same side of the cutting unit as the reel drive motor. Position the turf compensation as follows:

- A. Remove the 2 carriage bolts and nuts securing the rod bracket to the cutting unit tabs (Figure 4).

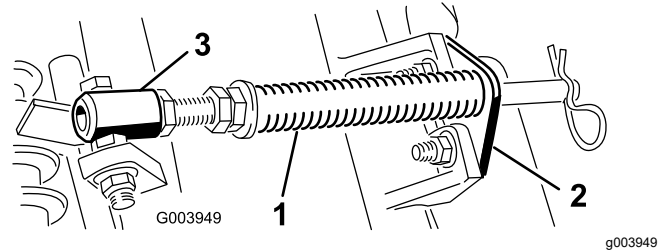

Figure 4

1. Turf compensation spring
2. Rod bracket
3. Spring tube

- B. Remove the flange nut securing the spring tube bolt to the carrier frame tab (Figure 4), and remove the assembly.
- C. Mount the spring tube bolt to the opposite tab on the carrier frame and secure it with the flange nut.

**Note:** Position the bolt head to the outer side of the tab as shown in Figure 4.

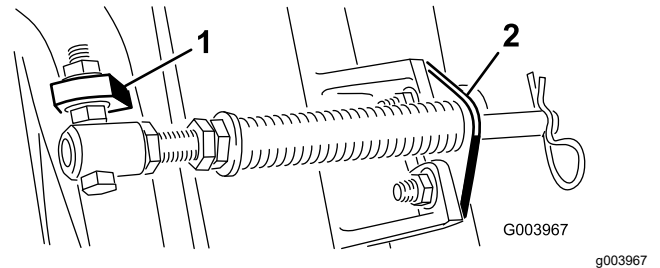

Figure 5

1. Opposite carrier frame tab
2. Rod bracket

- D. Mount the rod bracket to the cutting unit tabs with the carriage bolts and nuts (Figure 5).

**Note:** When installing or removing the cutting units, make sure that the hairpin cotter is installed in the spring rod hole next to the rod bracket. Otherwise, the hairpin cotter must be installed in the hole in the end of the rod.

7. Lower all the lift arms completely.
8. Remove the snapper pin and the cap from the lift-arm pivot yoke (Figure 6).

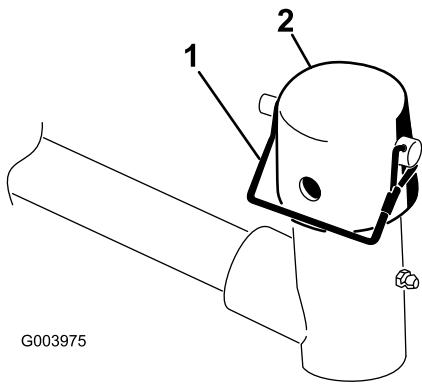

**Figure 6**

1. Snapper pin
2. Cap

9. For the front cutting units, slide a cutting unit under the lift arm while inserting the carrier frame shaft up into the lift-arm pivot yoke (Figure 7).

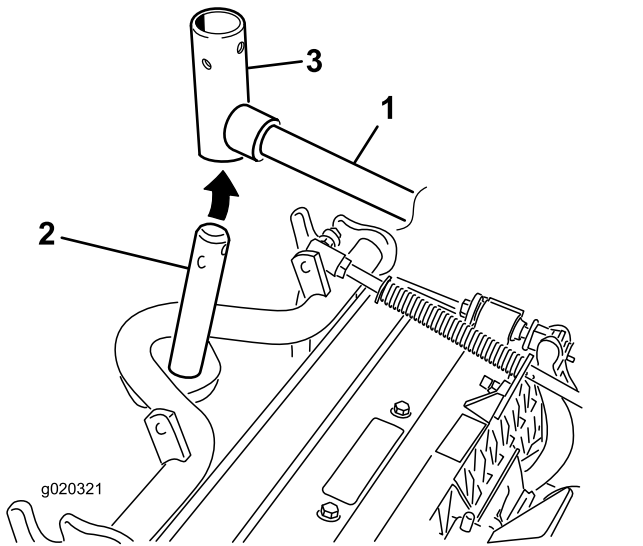

**Figure 7**

1. Lift arm
2. Carrier frame shaft
3. Lift-arm pivot yoke

10. Use the following procedure on the rear cutting units when the height of cut is above 1.2 cm (3/4 inch).
  - A. Remove the lynch pin and washer securing the lift-arm pivot shaft to the lift arm and slide the lift-arm pivot shaft out of the lift arm (Figure 8).

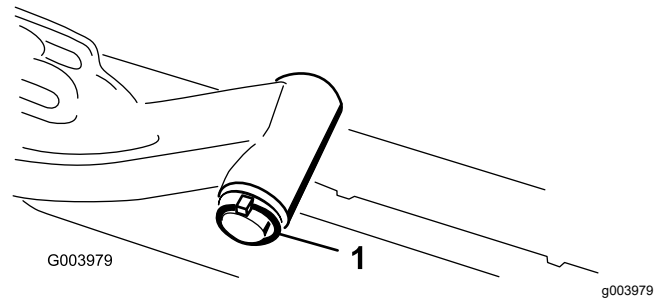

**Figure 8**

1. Lift-arm shaft lynch pin and washer

- B. Insert the lift-arm yoke onto the carrier frame shaft (Figure 7).
- C. Insert the lift-arm shaft into the lift arm and secure it with the washer and lynch pin (Figure 8).

11. Insert the cap over the carrier frame shaft and lift-arm yoke.
12. Secure the cap and the carrier frame shaft to the lift-arm yoke with the snapper pin.

**Note:** You can use the slot for a steering cutting unit or use the hole to lock the cutting unit in position (Figure 9).

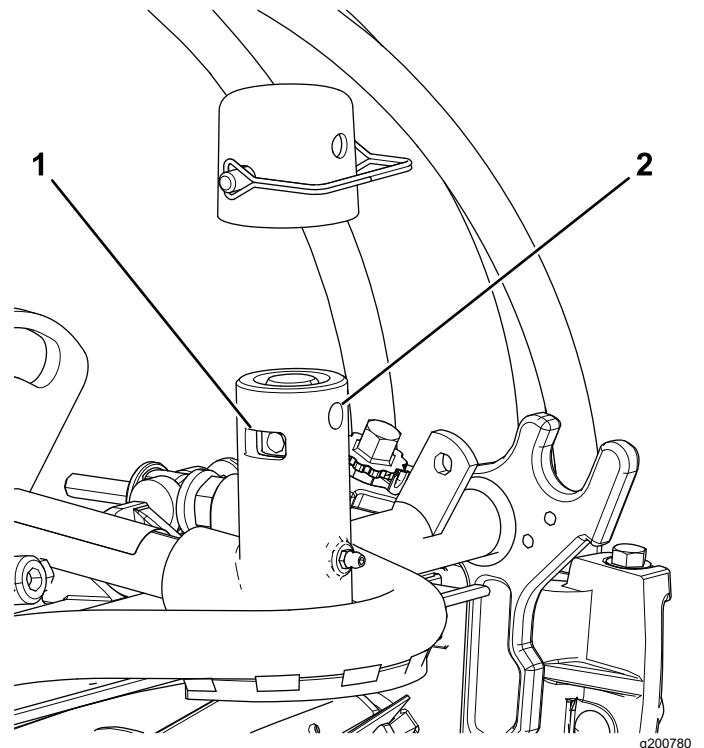
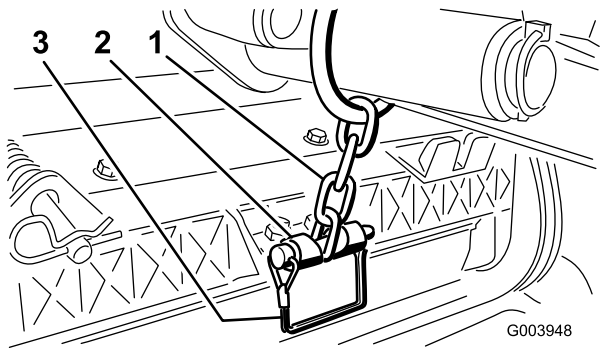

**Figure 9**

1. Slot
2. Hole

13. Secure the lift-arm chain to the chain bracket with the snapper pin (Figure 10).

**Note:** Use the number of chain links specified in the cutting unit *Operator's Manual*.

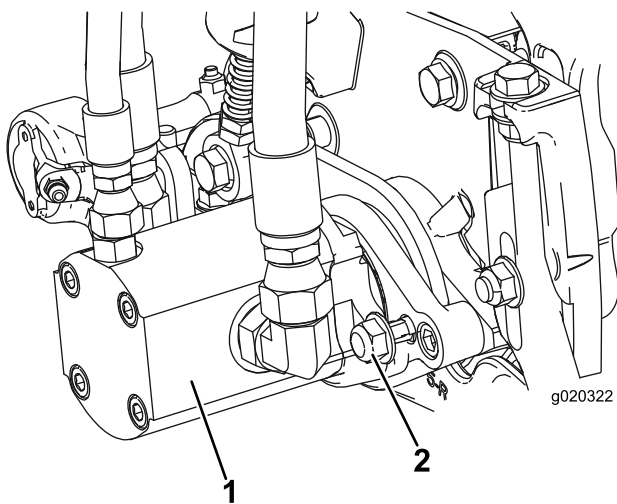

**Figure 10**

- |                   |                |
|-------------------|----------------|
| 1. Lift-arm chain | 3. Snapper pin |
| 2. Chain bracket  |                |

- 
14. Coat the spline shaft of the reel motor with clean grease.
  15. Oil the reel-motor O-ring and install it onto the motor flange.
  16. Install the motor by rotating it clockwise so that the motor flanges clear the locknuts (Figure 11). Rotate the motor counterclockwise until the flanges encircle the nuts then tighten the nuts.

**Important:** Make sure that the reel motor hoses are not twisted, kinked, or at risk of being pinched.



**Figure 11**

- |                     |                  |
|---------------------|------------------|
| 1. Reel-drive motor | 2. Mounting nuts |
|---------------------|------------------|

# 2

## Adjusting the Turf Compensation Spring

**No Parts Required**

### Procedure

The turf compensation spring (Figure 12) transfers weight from the front to the rear roller. This helps to reduce a wave pattern in the turf, also known as marcelling or bobbing.

**Important:** Make spring adjustments with the cutting unit mounted to the traction unit, pointing straight ahead and lowered to the shop floor.

1. Make sure that the hairpin cotter is installed in the rear hole in the spring rod (Figure 12).

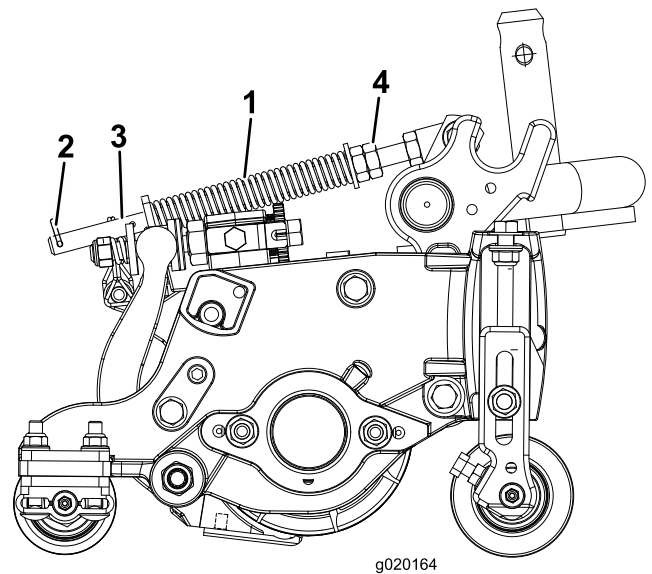

**Figure 12**

- |                             |               |
|-----------------------------|---------------|
| 1. Turf compensation spring | 3. Spring rod |
| 2. Hairpin cotter           | 4. Hex nuts   |

2. Tighten the hex nuts on the front end of the spring rod until the compressed length of the spring (Figure 12) is 12.7 cm (5 inches).

**Note:** When operating on rough terrain, decrease the spring length by 2.5 cm (1/2 inch). Ground following will be slightly decreased.

# 3

## Installing the CE Decal

### Parts needed for this procedure:

1	Warning decal (120-1686)
---	--------------------------

### Procedure

If this machine will be used for CE, affix the warning decal 120-1686 over English warning decal 120-1683.

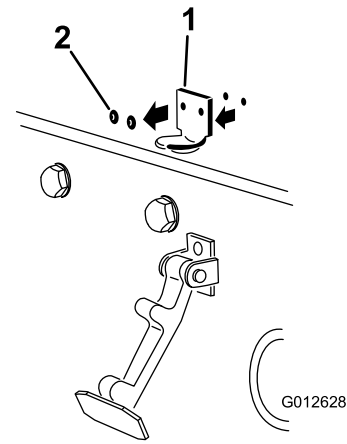

Figure 13

1. Hood-latch bracket
2. Rivets

g012628

# 4

## Installing the Hood Latch (CE Only)

### Parts needed for this procedure:

1	Lock bracket
2	Rivet
1	Washer
1	Screw (1/4 x 2 inches)
1	Locknut (1/4 inch)

### Procedure

1. Unhook the hood latch from the hood-latch bracket.
2. Remove the 2 rivets securing the hood-latch bracket to the hood (Figure 13) and remove the hood-latch bracket from the hood.

3. While aligning the mounting holes, position the CE lock bracket and the hood-latch bracket onto the hood.

**Note:** The lock bracket must be against the hood (Figure 14). Do not remove the bolt and nut from the lock-bracket arm.

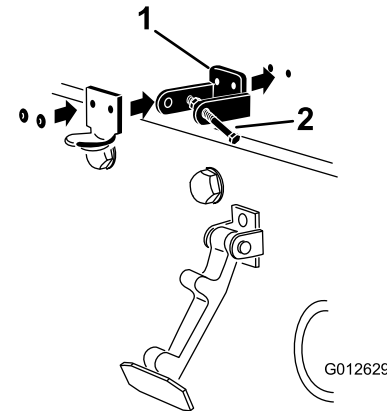
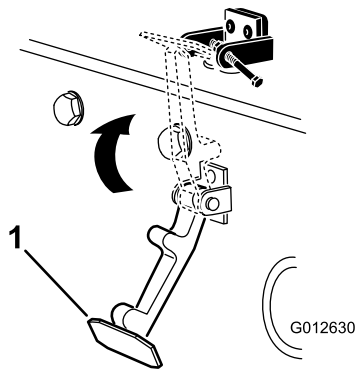

Figure 14

1. CE lock bracket
2. Bolt and nut

g012629

4. Align the washers with the holes on the inside of the hood.
5. Rivet the brackets and the washers to the hood (Figure 14).
6. Hook the latch onto the hood-latch bracket (Figure 15).



**Figure 15**

g012630

1. Hood latch

7. Screw the bolt into the other arm of the hood-lock bracket to lock the latch in position (Figure 16).

**Note:** Tighten the bolt securely but do not tighten the nut.

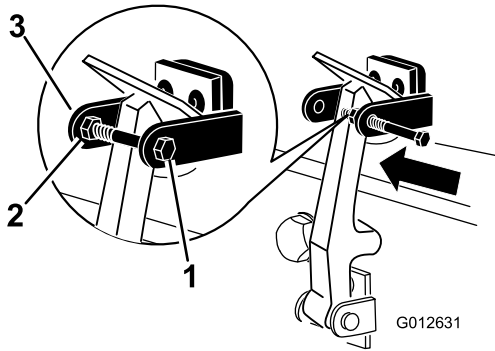

**Figure 16**

g012631

1. Bolt
2. Nut
3. Arm of hood-lock bracket

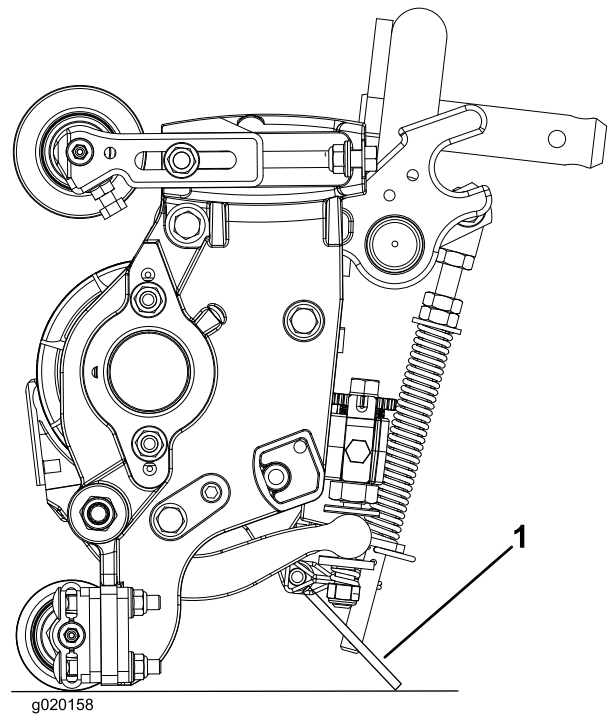
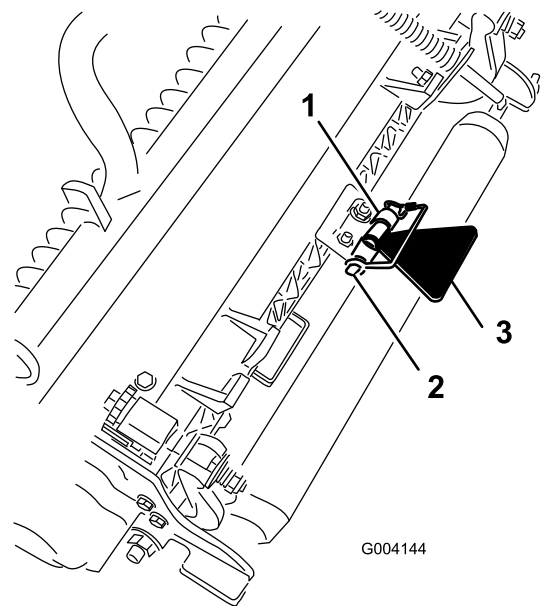

**Figure 17**

g020158

1. Cutting unit kickstand

Secure the kickstand to the chain bracket with the snapper pin (Figure 18).



**Figure 18**

g004144

1. Chain bracket
2. Snapper pin
3. Cutting unit kickstand

# 5

## Using the Cutting Unit Kickstand

Parts needed for this procedure:

1	Cutting unit kickstand
---	------------------------

### Procedure

Whenever the cutting unit has to be tipped to expose the bedknife/reel, prop up the rear of the cutting unit with the kickstand to make sure that the nuts on the back end of the bedbar adjusting screws are not resting on the work surface (Figure 17).



# Product Overview

## Controls

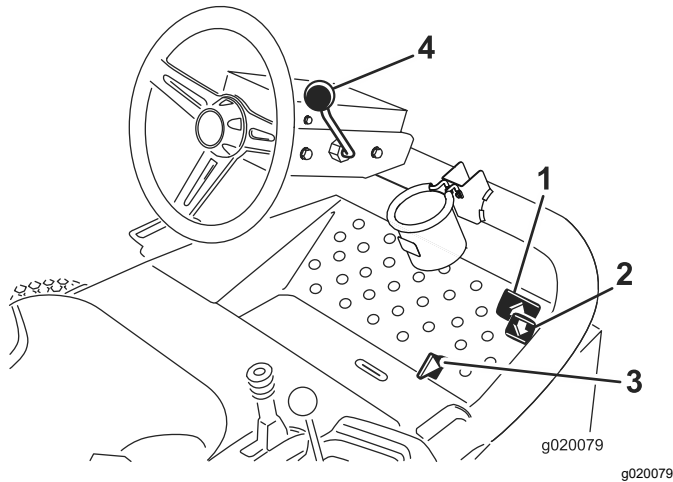

Figure 19

- |                           |                        |
|---------------------------|------------------------|
| 1. Forward traction pedal | 3. Mow/transport slide |
| 2. Reverse traction pedal | 4. Tilt-steering lever |

## Traction Pedals

Press the forward traction pedal (Figure 19) to move forward. Press reverse traction pedal (Figure 19) to move backward or to assist in stopping when moving forward. Also, allow the pedal to move or move it to the NEUTRAL position to stop the machine.

## Mow/Transport Slide

Using your heel, move the mow/transport slide (Figure 19) to the left to transport and to the right to mow. **The cutting units will only operate in the Mow position and not lower in the TRANSPORT position.**

**Important:** The mow speed is set at the factory to 9.7 km/h (6 mph). It can be increased or decreased by adjusting the speed stop screw (Figure 20).

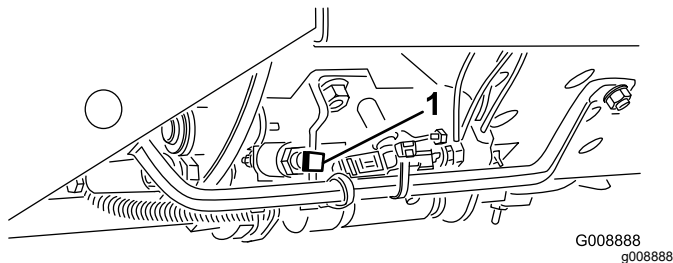

Figure 20

1. Speed stop screw

## Tilt-Steering Lever

Pull the tilt-steering lever (Figure 19) back to tilt the steering wheel to the desired position. Then push the lever forward to secure the position.

## Ignition Switch

The ignition switch (Figure 21), used to start, shut off, and preheat the engine, has 3 positions: OFF, ON/PREHEAT, and START. Rotate the key to the ON/PREHEAT position until the glow-plug indicator light goes out (approximately 7 seconds); then rotate the key to the START position to engage the starter motor. Release the key when the engine starts. The key moves automatically to the ON/RUN position. To shut off the engine, rotate the key to the OFF position. Remove the key from the switch to prevent accidental starting.

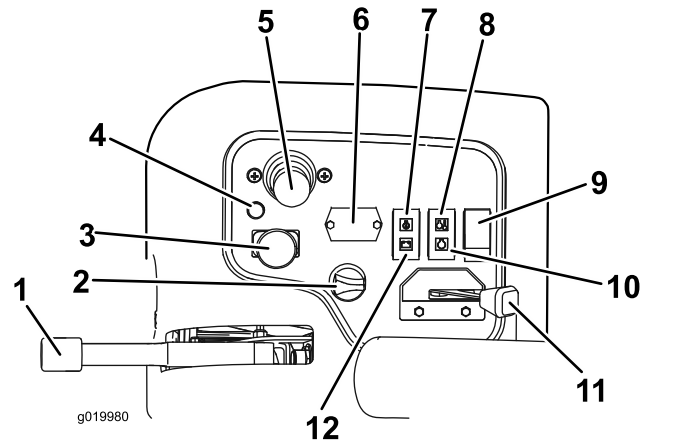

Figure 21

- |                                  |                               |
|----------------------------------|-------------------------------|
| 1. Parking brake                 | 7. Oil-pressure light         |
| 2. Ignition switch               | 8. Temperature light          |
| 3. Enable/Disable switch         | 9. Light switch               |
| 4. Diagnostic light              | 10. Glow-plug indicator light |
| 5. Lower mow/raise control lever | 11. Throttle                  |
| 6. Hour meter                    | 12. Alternator light          |

## Throttle

Move the throttle (Figure 21) forward to increase the engine speed and rearward to decrease the engine speed.

## Enable/Disable Switch

Use the enable/disable switch (Figure 21) in conjunction with the lower mow/raise control lever to operate the cutting units. **You cannot lower the cutting units when the mow/transport lever is in the TRANSPORT position.**



## Hour Meter

The hour meter (Figure 21) indicates the total hours of machine operation. It starts to function whenever the key switch is on.

## Lower Mow/Raise Control Lever

This lever (Figure 21) raises and lowers the cutting units and also starts and stops the reels when the reels are enabled in the mow mode. **You cannot lower the cutting units when the mow/transport lever is in the TRANSPORT position.**

**Note:** When the cutting units are enabled, you do not need to hold the lever in the forward position while the cutting units are lowered or raised.

## Engine Coolant Temperature Warning Light

The temperature warning light (Figure 21) glows if the engine coolant temperature is high. At this temperature, the cutting units are disabled. If the coolant temperature rises another 5.5° C (10° F), the engine shuts off to prevent further damage.

## Oil-Pressure Warning Light

The oil-pressure warning light (Figure 21) glows if the engine oil pressure drops below a safe level.

## Alternator Light

The alternator light (Figure 21) should be off when the engine is running. If it is on, check the charging system and repair it as necessary.

## Glow-Plug Indicator

The glow-plug indicator light (Figure 21) glows when the glow plugs are operating.

## Parking Brake

Whenever the engine is shut off, engage the parking brake (Figure 21) to prevent accidental movement of the machine. To engage the parking brake, pull up on the lever. The engine stops when you press the traction pedal with the parking brake engaged.

## Diagnostic Light

The diagnostic light (Figure 21) will illuminate if the system recognizes a system fault.

## Fuel Gauge

The fuel gauge (Figure 22) indicates the amount of fuel in the tank.

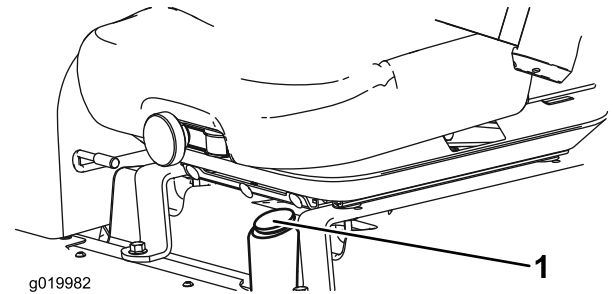

Figure 22

1. Fuel gauge

## Power Point

The power point, located on the outside of the control panel, is a 12 V power supply for electronic devices (Figure 23).

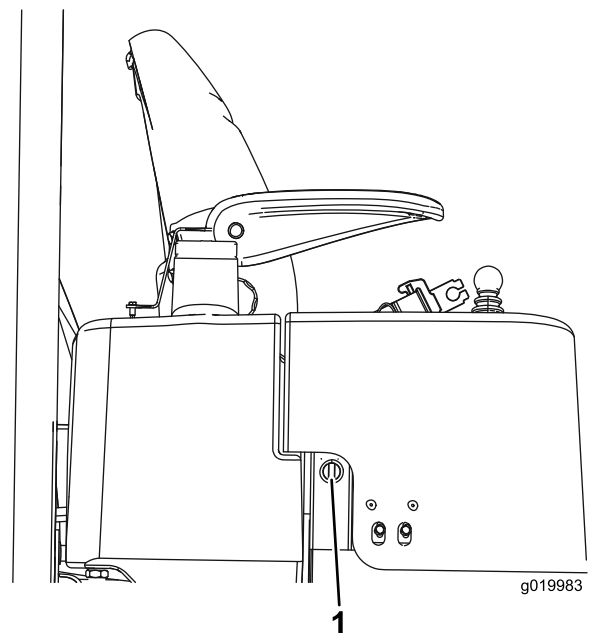

Figure 23

1. Power point

## Reel Speed Control Knob

The reel speed control controls the speed of the cutting units (Figure 24). The reel speed increases as you turn the knob counterclockwise. Refer to the reel speed chart decal (Figure 33), to determine the proper reel speed.

delivers replacement parts designed to the exact engineering specification of our equipment. For peace of mind, insist on Toro genuine parts.

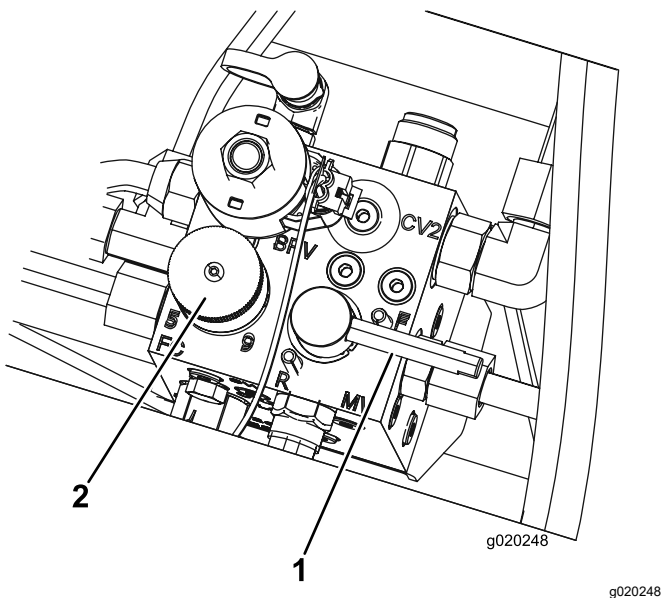

Figure 24

1. Backlap lever
2. Reel speed control knob

## Backlap Lever

Use the backlap lever in conjunction with the lower mow/raise control lever for the reels ([Figure 24](#)).

## Specifications

**Note:** Specifications and design are subject to change without notice.

Width of Cut	208 cm (82 inches)
Overall Width	239 cm (94 inches)
Transport Width	231 cm (91 inches)
Overall Length	295 cm (110 inches)
Height to top of ROPS	188 cm (74 inches)
Wheel Base	151 cm (59.5 inches)
Weight with 18 inch, 8 blade cutting units	900 kg (1985 lb)
Weight without cutting units	708 kg (1560 lb)

## Attachments/Accessories

A selection of Toro approved attachments and accessories is available for use with the machine to enhance and expand its capabilities. Contact your Authorized Service Dealer or Distributor or go to [www.Toro.com](http://www.Toro.com) for a list of all approved attachments and accessories.

To best protect your investment and maintain optimal performance of your Toro equipment, count on Toro genuine parts. When it comes to reliability, Toro

# Operation

**Note:** Determine the left and right sides of the machine from the normal operating position.

## Before Operation Safety

### General Safety

- Never allow children or untrained people to operate or service the machine. Local regulations may restrict the age of the operator. The owner is responsible for training all operators and mechanics.
- Become familiar with the safe operation of the equipment, operator controls, and safety signs.
- Know how to stop the machine and engine quickly.
- Check that operator-presence controls, safety switches, and shields are attached and functioning properly. Do not operate the machine unless they are functioning properly.
- Before mowing, always inspect the machine to ensure that the blades, blade bolts, and cutting assemblies are in good working condition. Replace worn or damaged blades and bolts in sets to preserve balance.
- Inspect the area where you will use the machine and remove all objects that the machine could throw.

### Fuel Safety

- Use extreme care in handling fuel. It is flammable and its vapors are explosive.
- Extinguish all cigarettes, cigars, pipes, and other sources of ignition.
- Use only an approved fuel container.
- Never remove the fuel cap or fill the fuel tank while the engine is running or hot.
- Never refuel the machine in an enclosed space.
- Never store the machine or fuel container where there is an open flame, spark, or pilot light, such as on a water heater or other appliance.
- If you spill fuel, do not attempt to start the engine; avoid creating any source of ignition until the fuel vapors have dissipated.

## Checking the Engine-Oil Level

**Service Interval:** Before each use or daily

The engine is shipped with oil in the crankcase; however, the oil level must be checked before and after the engine is first started.

Crankcase capacity is approximately 3.8 L (4 US qt) with the filter.

Use high-quality engine oil that meets the following specifications:

- API Classification Level Required: CH-4, CI-4 or higher.
- Preferred oil: SAE 15W-40 (above 0°F (-17°C))
- Alternate oil: SAE 10W-30 or 5W-30 (all temperatures)

**Note:** Toro Premium Engine Oil is available from your distributor in either 15W-40 or 10W-30 viscosity. Refer to the *Parts Catalog* for part numbers.

**Note:** The best time to check the engine oil is when the engine is cool before it has been started for the day. If it has already been run, allow the oil to drain back down to the sump for at least 10 minutes before checking. If the oil level is at or below the Add mark on the dipstick, add oil to bring the oil level to the Full mark. Do not overfill the engine. If the oil level is between the Full and Add marks, no oil addition is required.

1. Park the machine on a level surface, lower the cutting units, engage the parking brake, shut off the engine, and remove the key.
2. Remove the dipstick (Figure 25) and wipe it with a clean rag.

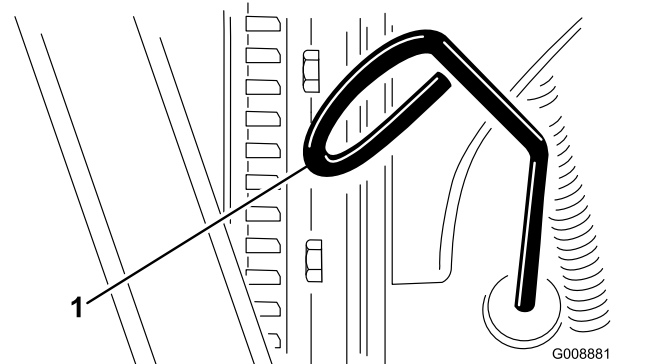

**Figure 25**

1. Dipstick

3. Push the dipstick down into the dipstick tube and make sure that it is seated fully. Pull the dipstick out and check the oil level.
4. If the oil level is low, remove the oil-fill cap (Figure 26) and gradually add small quantities of oil, checking the level frequently, until the level reaches the Full mark on the dipstick.

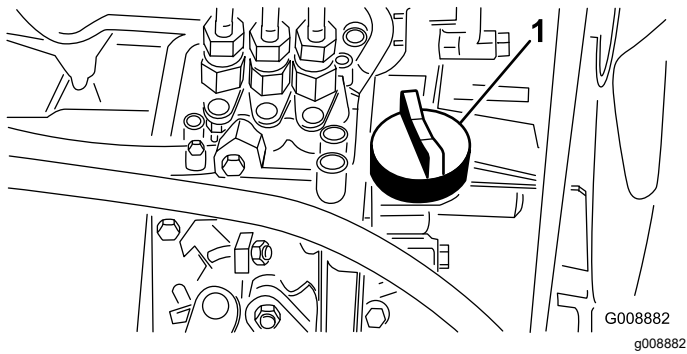

**Figure 26**

1. Oil-fill cap

5. Install the oil-fill cap and close the hood.

## Filling the Fuel Tank

Use only clean, fresh diesel fuel or biodiesel fuels with low (<500 ppm) or ultra low (<15 ppm) sulfur content. The minimum cetane rating should be 40. Purchase fuel in quantities that can be used within 180 days to ensure fuel freshness.

The fuel tank capacity is approximately 42 L (11 US gallons).

Use summer-grade diesel fuel (Number 2-D) at temperatures above  $-7^{\circ}\text{C}$  ( $20^{\circ}\text{F}$ ) and winter-grade diesel fuel (Number 1-D or Number 1-D/2-D blend) below  $-7^{\circ}\text{C}$  ( $20^{\circ}\text{F}$ ). Using winter-grade fuel at lower temperatures provides lower flash-point and cold-flow characteristics that ease starting and reduce plugging of the fuel filter.

Using summer-grade fuel above  $-7^{\circ}\text{C}$  ( $20^{\circ}\text{F}$ ) will contribute toward longer fuel pump life and increased power compared to winter-grade fuel.

### Biodiesel Ready

This machine can also use a biodiesel blended fuel of up to B20 (20% biodiesel, 80% petrodiesel). The petrodiesel portion should be low or ultra-low sulfur. Observe the following precautions:

- The biodiesel portion of the fuel must meet specification ASTM D6751 or EN14214.
- The blended fuel composition should meet ASTM D975 or EN590.
- Painted surfaces may be damaged by biodiesel blends.
- Use B5 (biodiesel content of 5%) or lesser blends in cold weather
- Monitor seals, hoses, and gaskets in contact with fuel as they may be degraded over time.

- Expect plugging of the fuel filter for a time after converting to biodiesel blends.
  - Contact your authorized Toro distributor for more information on biodiesel.
1. Park the machine on a level surface, lower the cutting units, engage the parking brake, shut off the engine, and remove the key.
  2. Clean the area around the fuel-tank cap ([Figure 27](#)).
  3. Remove the fuel-tank cap.
  4. Fill the tank to the bottom of the filler neck. **Do not overfill the tank.** Install the cap.
  5. Wipe up any spilled fuel.

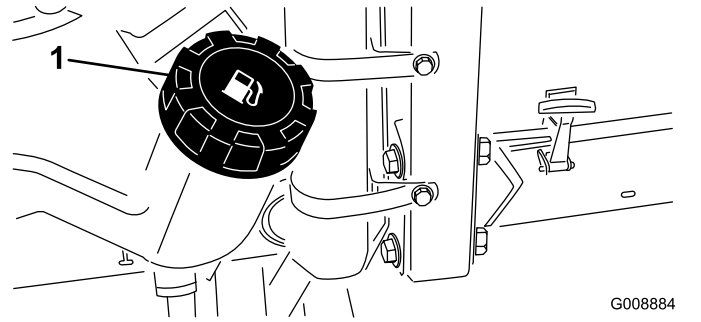

**Figure 27**

1. Fuel-tank cap

### **▲ DANGER**

**Under certain conditions, fuel and fuel vapors are highly flammable and explosive. A fire or explosion from fuel can burn you and others and can cause property damage.**

**Do not fill the fuel tank completely full. Add fuel to the fuel tank until the level is 6 to 13 mm (1/4 to 1/2 inch) below the bottom of the filler neck. This empty space in the tank allows the fuel to expand.**

# Checking the Cooling System

**Service Interval:** Before each use or daily

Clean debris off the radiator daily (Figure 28). Clean the radiator hourly if conditions are extremely dusty and dirty; refer to [Cleaning the Engine Cooling System](#) (page 42).

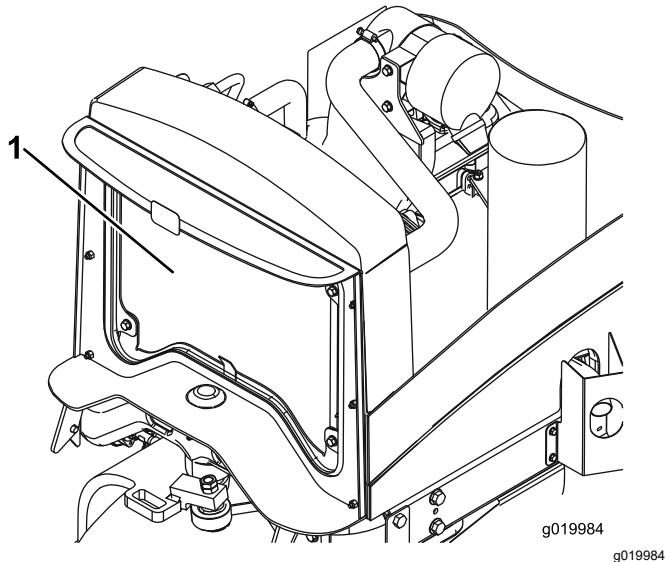

Figure 28

1. Radiator

The cooling system is filled with a 50/50 solution of water and permanent ethylene glycol antifreeze. Check the coolant level at the beginning of each day before starting the engine.

The capacity of the cooling system is approximately 5.7 L (6 US qt).

## ⚠ CAUTION

If the engine has been running, the pressurized, hot coolant can escape and cause burns.

- Do not open the radiator cap when the engine is running.
  - Use a rag when opening the radiator cap, and open the cap slowly to allow steam to escape.
1. Park the machine on a level surface, lower the cutting units, engage the parking brake, shut off the engine, and remove the key.
  2. Check the coolant level in the expansion tank (Figure 29). With a cold engine, the coolant level should be approximately midway between the marks on the side of the tank.

3. If the coolant level is low, remove the expansion-tank cap and replenish the system. **Do not overfill the tank.**
4. Install the expansion-tank cap.

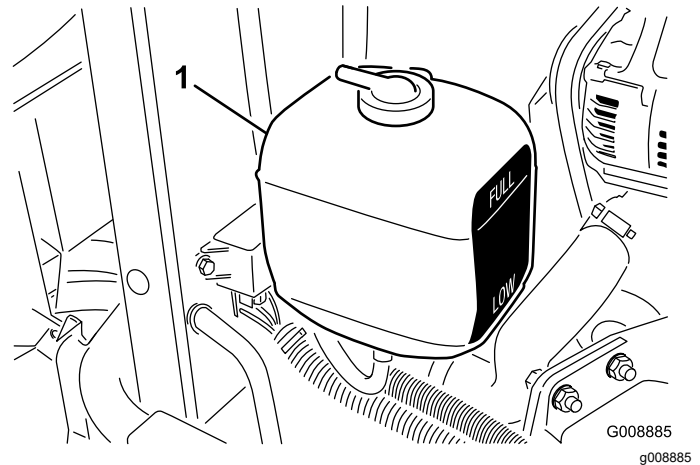

Figure 29

1. Expansion tank

# Checking the Hydraulic System

**Service Interval:** Before each use or daily—Check the hydraulic-fluid level.

The reservoir is filled at the factory with approximately 13.2 L (3.5 US gallons) of high-quality hydraulic fluid. The best time to check the hydraulic fluid is when the fluid is cold. The machine should be in its transport configuration. If the fluid level is below the Add mark on the dipstick, add fluid to bring the fluid level to the middle of the acceptable range. **Do not overfill the reservoir.** If the fluid level is between the Full and the Add marks, no fluid addition is required.

Use **Toro Premium All Season Hydraulic Fluid** (available in 19 L (5 gallon) containers or 208 L (55 gallon) drums—see the parts documentation or your Toro distributor for part numbers).

Alternative fluids: If the Toro fluid is not available, you may use other conventional, petroleum-based fluids, provided that they meet all the following material properties and industry specifications. Check with your fluid supplier to see whether the fluid meets these specifications.

**Note:** Toro will not assume responsibility for damage caused by improper substitutions, so use only products from reputable manufacturers who will stand behind their recommendation.

**High Viscosity Index/Low Pour Point Antiwear Hydraulic Fluid, ISO VG 46 Multigrade**

Material Properties:



Viscosity, ASTM D445	cSt @ 40°C (104°F) 44 to 48
	cSt @ 100°C (212°F) 7.9 to 9.1
Viscosity index, ASTM D2270	140 or higher (high viscosity index indicates a multiweight fluid)
Pour point, ASTM D97	-36.7°C to -45°C (-34°F to -49°F)
FZG, fail stage	11 or better
Water content (new fluid)	500 ppm (maximum)
Industry Specifications:	
	Vickers I-286-S, Vickers M-2950-S, Denison HF-0, Vickers 35 VQ 25 (Eaton ATS373-C)

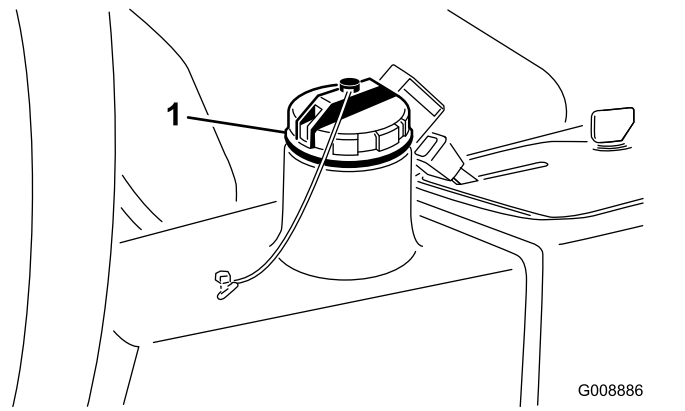

**Figure 30**

The proper hydraulic fluids must be specified for mobile machinery (as opposed to industrial plant usage), multiweight-type, with ZnDTP or ZDDP anti-wear additive package (not an ashless-type fluid).

**Important:** Many hydraulic fluids are almost colorless, making it difficult to spot leaks. A red dye additive for the hydraulic system fluid is available in 20 ml (2/3 fl oz) bottles. One bottle is sufficient for 15 to 22 L (4 to 6 US gallons) of hydraulic fluid. Order Part No. 44-2500 from your authorized Toro distributor.

**Synthetic, Biodegradable Hydraulic Fluid** is available in 19 L (5 gallon) containers or 208 L (55 gallon) drums—see the parts documentation or your Toro distributor for part numbers.

This high-quality, synthetic, biodegradable fluid has been tested and found compatible for this Toro model. Other brands of synthetic fluid may have seal compatibility problems and Toro cannot assume responsibility for unauthorized substitutions.

**Note:** This synthetic fluid is not compatible with the Toro Biodegradable Fluid previously sold. See your Toro distributor for more information.

Alternative fluids:

- Mobil EAL Envirosyn H 46 (US)
  - Mobil EAL Hydraulic Oil 46 (international)
1. Park the machine on a level surface, lower the cutting units, engage the parking brake, shut off the engine, and remove the key.
  2. Clean the area around the filler neck and cap of the hydraulic tank (Figure 30). Remove the cap.

1. Hydraulic-tank cap

3. Remove the dipstick from the filler neck and wipe it with a clean rag. Insert the dipstick into the filler neck; then remove it and check the fluid level. The fluid level should be within 6 mm (1/4 inch) of the mark on the dipstick.
4. If the level is low, add the appropriate fluid to raise the level to the Full mark.
5. Install the dipstick and cap onto the filler neck.

## Checking the Reel-to-Bedknife Contact

Each day before operating, check the reel-to-bedknife contact, regardless of whether the quality of cut had previously been acceptable. There must be light contact across the full length of the reel and the bedknife (refer to Adjusting the Reel to Bedknife in the cutting unit *Operator's Manual*).

## Checking the Tire Pressure

**Service Interval:** Before each use or daily

The tires are over-inflated for shipping. Therefore, release some of the air to reduce the pressure. The correct air pressure in the tires is 83 kPa (12 psi).

**Note:** Maintain the recommended pressure in all tires to ensure a good quality of cut and proper machine performance.

### **▲ DANGER**

**Low tire pressure decreases machine side hill stability. This could cause a rollover, which may result in personal injury or death.**

**Do not under-inflate the tires.**

# Torquing the Wheel Nuts

**Service Interval:** After the first hour

After the first 10 hours

Every 200 hours

Torque the wheel nuts to 61 to 88 N·m (45 to 65 ft-lb).

## ⚠ WARNING

**Failure to maintain proper torque of the wheel nuts could result in personal injury.**

**Maintain proper torque of the wheel nuts.**

# Checking the Parking Brake

**Service Interval:** Before each use or daily

1. Start the engine, raise the cutting units, disengage the parking brake, and move the machine to an open flat area.
2. Engage the parking brake (Figure 31).

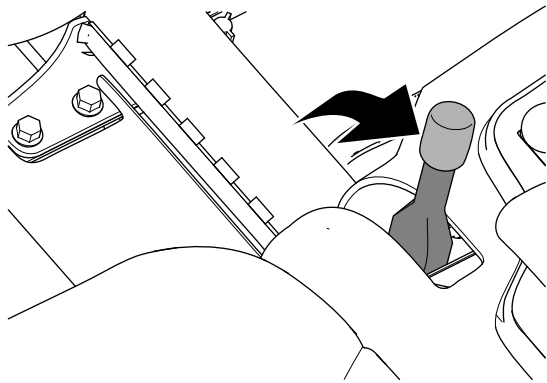

Figure 31

3. Press the traction pedal to move the machine forward.

**Note:** If the machine moves forward with the parking brake engaged, adjust parking brake; refer to [Adjusting the Parking Brake \(page 43\)](#).

**Note:** Moving the machine forward with the parking brake engaged will cause the engine to shutoff.

4. If you adjusted the parking brake, repeat steps 2 and 3.

**Note:** If the machine moves forward with the parking brake engaged: service the parking brakes, check left and right brake linkage for damage, and check the brake lever pivot for damage; refer to [Servicing the Parking Brakes \(page 43\)](#).

5. Shut off the engine, remove the key, and wait for all moving parts to stop before leaving the operator's seat.

# Positioning the Seat

## Changing the Seat Position

The seat can move forward and backward. Position the seat where you have the best control of the machine and are most comfortable.

1. Move the lever sideways to unlock the seat (Figure 32).
2. Slide the seat to the desired position and release the lever to lock it in position.

## Changing the Seat Suspension

You can adjust the seat to provide a smooth and comfortable ride. Position the seat where you are most comfortable.

To adjust it, turn the front knob in either direction to provide the best comfort (Figure 32).

## Changing the Back Position

You can adjust the back of the seat to provide a comfortable ride. Position the back of the seat where it is most comfortable.

To adjust it, turn the knob under the right armrest, in either direction, to provide the best comfort (Figure 32).

## Changing the Armrest Position

You can adjust the armrests to provide a comfortable ride. Position the armrests where they are most comfortable.

Raise the armrest and turn the knob, in either direction, to provide the best comfort (Figure 32).

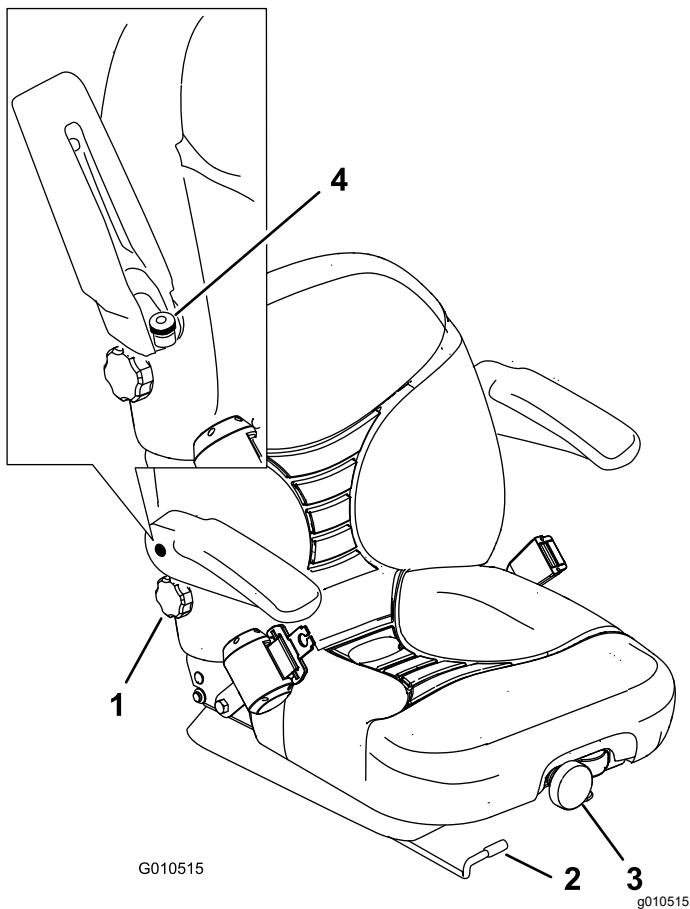

**Figure 32**

- |                                   |                           |
|-----------------------------------|---------------------------|
| 1. Backrest knob                  | 3. Seat-suspension knob   |
| 2. Seat-position adjustment lever | 4. Armrest-adjusting knob |

## During Operation Safety

### General Safety

- The owner/operator can prevent and is responsible for accidents that may cause personal injury or property damage.
- Wear appropriate clothing, including eye protection; slip-resistant, substantial foot protection; and hearing protection. Tie back long hair and do not wear jewelry.
- Do not operate the machine while ill, tired, or under the influence of alcohol or drugs.
- Never carry passengers on the machine and keep bystanders and pets away from the machine during operation.
- Operate the machine only in good visibility to avoid holes or hidden hazards.
- Avoid mowing on wet grass. Reduced traction could cause the machine to slide.

- Before you start the engine, ensure that all drives are in neutral, the parking brake is engaged, and you are in the operating position.
- Keep your hands and feet away from the cutting units. Keep clear of the discharge opening at all times.
- Look behind and down before backing up to be sure of a clear path.
- Use care when approaching blind corners, shrubs, trees, or other objects that may obscure your vision.
- Do not mow near drop-offs, ditches, or embankments. The machine could suddenly roll over if a wheel goes over the edge or if the edge gives way.
- Stop the reels whenever you are not mowing.
- Stop the machine and inspect the cutting units after striking an object or if there is an abnormal vibration in the machine. Make all necessary repairs before resuming operation.
- Slow down and use caution when making turns and crossing roads and sidewalks with the machine. Always yield the right-of-way.
- Disengage the drive to the cutting unit and shut off the engine before adjusting the height of cut (unless you can adjust it from the operating position).
- Never run an engine in an area where exhaust gasses are enclosed.
- Never leave a running machine unattended.
- Before leaving the operating position (including to empty the catchers or to unclog the chute), do the following:
  - Park the machine on level ground.
  - Disengage the power take-off and lower the attachments.
  - Engage the parking brake.
  - Shut off the engine and remove the key.
  - Wait for all moving parts to stop.
- Do not operate the machine when there is the risk of lightning.
- Do not use the machine as a towing vehicle.
- Use accessories, attachments, and replacement parts approved by The Toro® Company only.

### Rollover Protection System (ROPS) Safety

- **Do not** remove the ROPS from the machine.
- Ensure that the seat belt is attached and that you can release it quickly in an emergency.
- Check carefully for overhead obstructions and do not contact them.



- Keep the ROPS in safe operating condition by thoroughly inspecting it periodically for damage and keeping all the mounting fasteners tight.
- Replace a damaged ROPS. Do not repair or alter it.

### Machines with a Fixed Roll Bar

- The ROPS is an integral safety device.
- Always wear your seat belt.

### Slope Safety

- Establish your own procedures and rules for operating on slopes. These procedures must include surveying the site to determine which slopes are safe for machine operation. Always use common sense and good judgment when performing this survey.
- Slopes are a major factor related to loss-of-control and tip-over accidents, which can result in severe injury or death. Operating the machine on any slope requires extra caution.
- Operate the machine at a lower speed when you are on a slope.
- If you feel uneasy operating the machine on a slope, do not do it.
- Watch for holes, ruts, bumps, rocks, or other hidden objects. Uneven terrain could overturn the machine. Tall grass can hide obstacles.
- Choose a low ground speed so you will not have to stop or shift while on a slope.
- A rollover can occur before the tires lose traction.
- Avoid operating the machine on wet grass. Tires may lose traction; regardless if the brakes are available and functioning.
- Avoid starting, stopping, or turning the machine on a slope.
- Keep all movement on slopes slow and gradual. Do not suddenly change the speed or direction of the machine.
- Do not operate the machine near drop-offs, ditches, embankments, or bodies of water. The machine could suddenly roll over if a wheel goes over the edge or the edge caves in. Establish a safety area between the machine and any hazard (2 machine widths).

## Starting and Shutting Off the Engine

You may need to bleed the fuel system if any of the following situations have occurred; refer to [Bleeding the Fuel System \(page 27\)](#):

- Initial startup of a new engine
- The engine has ceased running due to lack of fuel.
- Maintenance has been performed upon the fuel system components; i.e. filter replaced, etc.

## Starting the Engine

1. Ensure that the parking brake is engaged and the cutting unit drive switch is in the DISENGAGE position.
2. Remove your foot from the traction pedal and ensure that the pedal is in the NEUTRAL position.
3. Move the throttle lever to the 1/2 throttle position.
4. Insert the key into the switch and rotate it to the ON/PREHEAT position until the glow-plug indicator light goes out (approximately 7 seconds); then rotate the key to the START position to engage the starter motor.

**Note:** Release the key when the engine starts. The key will move automatically to the ON/RUN position.

**Important:** To prevent overheating of the starter motor, do not engage the starter for longer than 15 seconds. After 10 seconds of continuous cranking, wait 60 seconds before engaging the starter motor again.

5. When the engine is started for the first time or after an overhaul of the engine, operate the machine in forward and reverse for 1 to 2 minutes. Also operate the lift lever and cutting unit drive switch to ensure proper operation of all parts.

Turn the steering wheel to the left and right to check steering response; then shut off the engine and check for oil leaks, loose parts, and any other noticeable malfunctions.

### **▲ CAUTION**

**Contact with moving parts could result in injury.**

**Shut off the engine and wait for all moving parts to stop before checking for oil leaks, loose parts, and other malfunctions.**

## Shutting Off the Engine

Move the throttle control to the IDLE position, move the cutting unit drive switch to DISENGAGE, and rotate the starter key to OFF. Remove the key from the switch to prevent accidental starting.

# Setting the Reel Speed

To achieve a consistent, high quality of cut and a uniform after cut appearance, it is important that you set the reel speed controls (located under the seat) correctly. Adjust the reel speed controls as follows:

1. Select the height of cut at which the cutting units are set.
2. Choose the desired ground speed best suited for conditions.
3. Use the graph on the reel speed chart decal (Figure 33), to determine the proper reel speed setting.

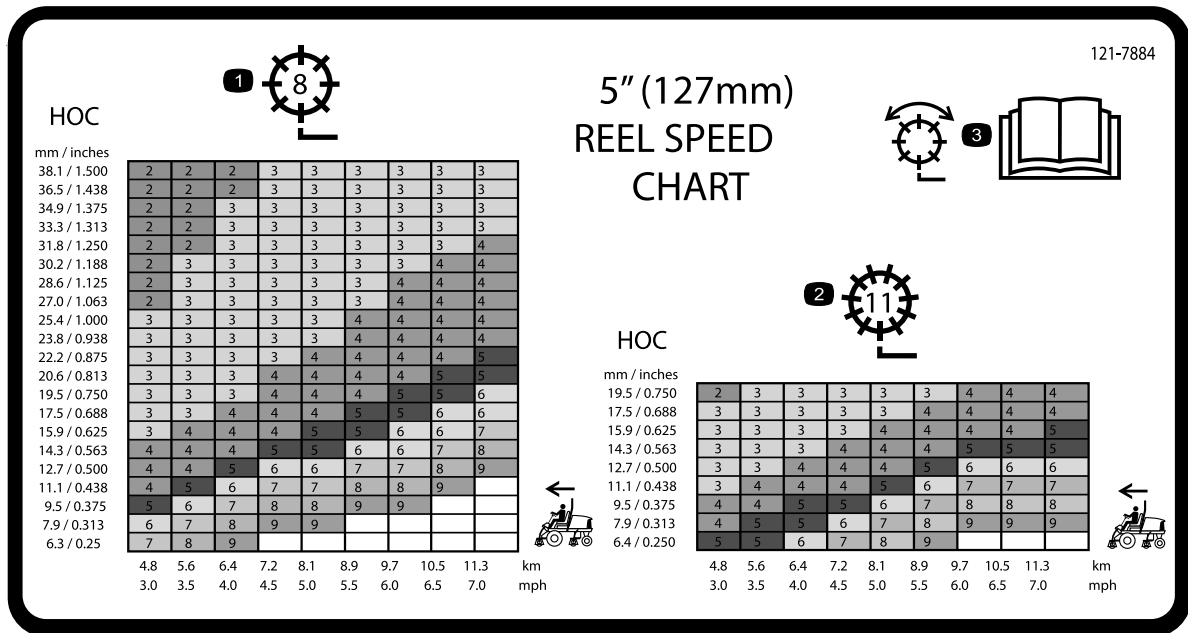

Figure 33

decal121-7884

1. 8-blade reel adjustment
2. 11-blade reel adjustment
3. Read the *Operator's Manual* for information on adjusting the reel.
4. To set the reel speed, rotate the knob (Figure 34) until the indicator arrow is in line with the number designating the desired setting.

**Note:** You can increase or decrease the reel speed to compensate for turf conditions. When using baskets, increase the reel speed to improve collection performance.

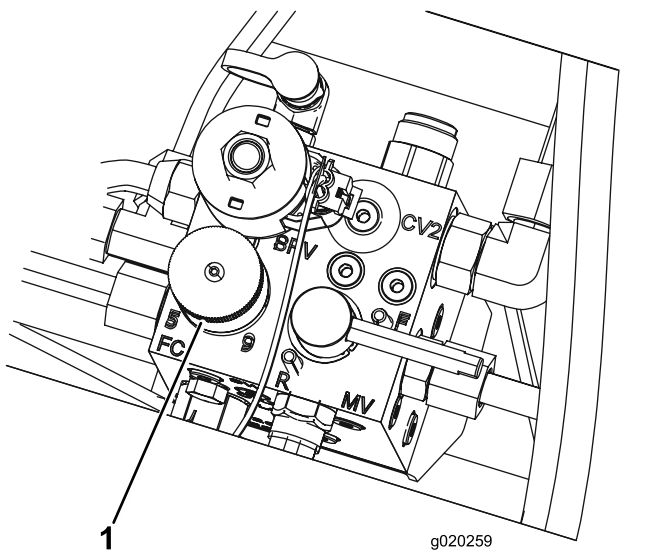

Figure 34

1. Reel speed control knob

## Adjusting the Lift Arm Counterbalance

You can adjust the counterbalance on the rear cutting unit lift arms to compensate for different turf conditions and to maintain a uniform height of cut in rough conditions or in areas of thatch buildup.

You can adjust each counterbalance spring to 1 of 4 settings. Each increment increases or decreases counterbalance on the cutting unit by 1.4 kg (3 lb). Position the springs on the back side of the first spring actuator to remove all counterbalance (fourth position).

1. Park the machine on a level surface, lower the cutting units, engage the parking brake, shut off the engine, and remove the key from the ignition switch.

- Insert a tube or similar object onto the long spring end to relieve the spring tension during the adjustment (Figure 35).

### ⚠ CAUTION

The springs are under tension and could cause personal injury.

Use caution when adjusting them.

- While relieving the spring tension, remove the bolt and locknut securing the spring actuator to the bracket (Figure 35).

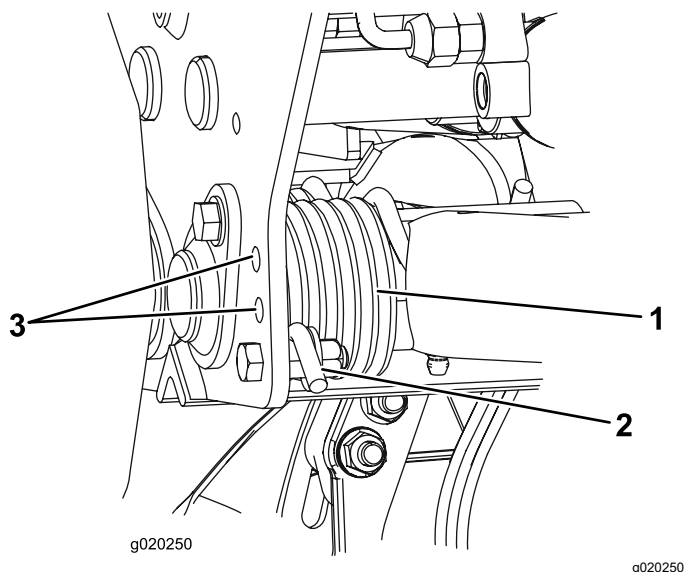

Figure 35

- |                    |                              |
|--------------------|------------------------------|
| 1. Spring          | 3. Additional hole locations |
| 2. Spring actuator |                              |

- Move the spring actuator to the desired hole location and secure it with the bolt and the locknut.
- Repeat the procedure on the remaining spring.

## Bleeding the Fuel System

- Park the machine on a level surface, lower the cutting units, engage the parking brake, shut off the engine, and remove the key.
- Ensure that the fuel tank is at least half full.
- Unlatch and raise the hood.

### ⚠ DANGER

Under certain conditions, fuel and fuel vapors are highly flammable and explosive. A fire or explosion from fuel can burn you and others and can cause property damage.

Do not fill the fuel tank completely full. Add fuel to the fuel tank until the level is 6 to 13 mm (1/4 to 1/2 inch) below the bottom of the filler neck. This empty space in the tank allows the fuel to expand.

- Open the air-bleed screw on the fuel-injection pump (Figure 36).

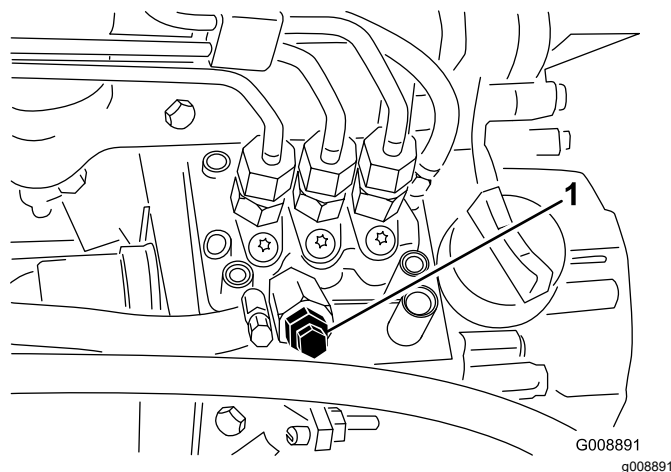

Figure 36

- Fuel-injection pump bleed screw

- Turn the key in the ignition switch to the ON position. The electric fuel pump will begin operation, thereby forcing air out around the air-bleed screw.

**Note:** Leave the key in the ON position until a solid stream of fuel flows out around the screw.

- Tighten the screw and turn the ignition key to OFF.

**Note:** Normally the engine should start after the above bleeding procedures are followed. However, if the engine does not start, air may be trapped between the injection pump and injectors; refer to [Bleeding Air from the Injectors](#) (page 39).

# Understanding the Diagnostic Light

The machine comes with a diagnostic light that indicates if the electronic controller senses an electronic malfunction. The diagnostic light is located on the control panel ([Figure 37](#)). When the electronic controller is functioning correctly and the key switch is moved to the ON position, the controller diagnostic light will turn on for 3 seconds and turn off to indicate that the light is working properly. If the machine stalls, the light will turn on steady until you change the key position. The light blinks if the controller detects a malfunction in the electrical system. The light stops blinking and automatically resets when you turn the key switch to the OFF position once the fault has been resolved.

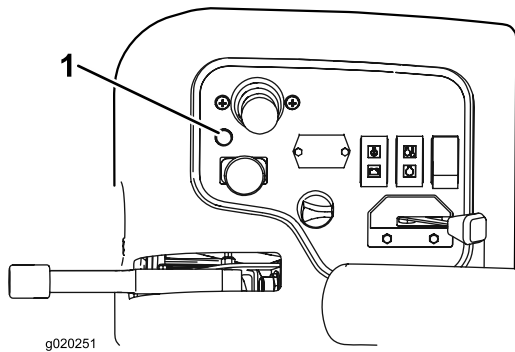

**Figure 37**

1. Diagnostic light

When the controller diagnostic light blinks, one of the following problems has been detected by the controller:

- 1 of the outputs has been shorted.
- 1 of the outputs is open circuited.

Using the diagnostic display, determine which output is malfunctioning; refer to [Checking the Interlock Switches \(page 29\)](#).

If the diagnostic light is not illuminated when the key switch is in the ON position, this indicates that the electronic controller is not operating. Possible causes are as follows:

- Loop-back is not connected
- The light is burned out.
- Fuses are blown.
- It is not functioning correctly.

Check the electrical connections, input fuses, and diagnostic light bulb to determine the malfunction. Ensure that the loop-back connector is secured to the wire harness connector.

# Understanding the Diagnostic ACE Display

The machine is equipped with an electronic controller which controls most machine functions. The controller determines what function is required for various input switches (i.e., seat switch, key switch, etc.) and turns on the outputs to actuate solenoids or relays for the requested machine function.

For the electronic controller to control the machine as desired, each of the input switches, output solenoids, and relays must be connected and functioning properly.

Use the Diagnostic ACE display to help verify and correct electrical functions of the machine.

# Checking the Interlock Switches

**Service Interval:** Before each use or daily

The purpose of the interlock switches is to prevent the engine from cranking or starting unless the traction pedal is in the NEUTRAL position, the Enable/Disable switch is in the DISABLE position, and the Lower Mow/Raise control is in the NEUTRAL position. In addition, the engine should shut off when you press the traction pedal with no one in the seat or if the parking brake is engaged.

## ⚠ CAUTION

If safety interlock switches are disconnected or damaged, the machine could operate unexpectedly, causing personal injury.

- Do not tamper with the interlock switches.
- Check the operation of the interlock switches daily and replace any damaged switches before operating the machine.

## Verifying the Interlock Switch Function

1. Park the machine on a level surface, lower the cutting units, engage the parking brake, and shut off the engine.
2. Remove the cover from the control panel.
3. Locate the wire harness and loop-back connector (Figure 38).

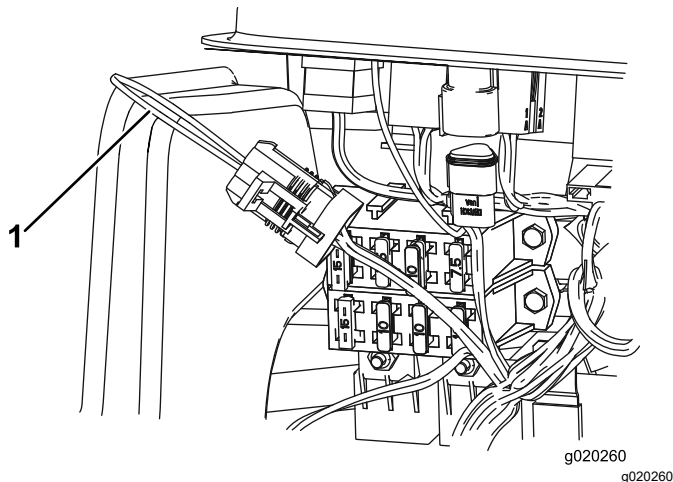

Figure 38

1. Loop-back connector

4. Carefully unplug the loop-back connector from the harness connector.
5. Connect the Diagnostic ACE display connector to the harness connector (Figure 39).

**Note:** Ensure that the correct overlay decal is positioned on the Diagnostic ACE display.

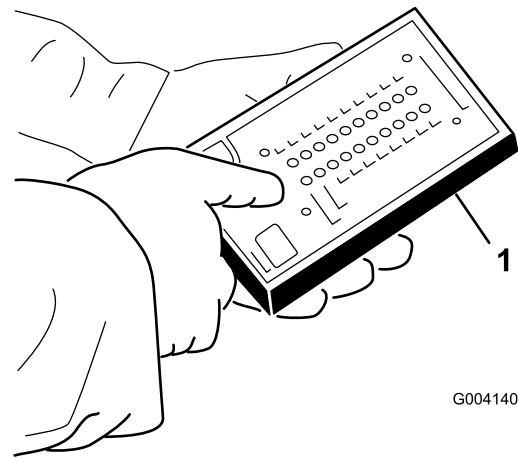

Figure 39

1. Diagnostic ACE

6. Turn the key switch to the ON position, but do not start the machine.

**Note:** The red text on the overlay decal refers to input switches and the green text refers to outputs.

7. The “inputs displayed” LED, on the lower right column of the Diagnostic ACE, should be illuminated. If the “outputs displayed” LED is illuminated, press the toggle button, on Diagnostic ACE, to change LED to “inputs displayed.”

The Diagnostic ACE illuminates the LED associated with each of the inputs when that input switch is closed.

8. Individually, change each of the switches from open to closed (i.e., sit on the seat, engage the traction pedal, etc.), and note that the appropriate LED on the Diagnostic ACE blinks on and off when the corresponding switch is closed. Repeat this for all switches that you can change by hand.
9. If a switch is closed and the appropriate LED does not turn on, check all wiring and connections to the switch and/or check the switches with an ohm meter or multimeter. Replace any malfunctioning switches and repair any malfunctioning wiring.

**Note:** The Diagnostic ACE also has the ability to detect which output solenoids or relays are turned on. This is a quick way to determine if a machine malfunction is electrical or hydraulic.



## Verifying Output Function

1. Park the machine on a level surface, lower the cutting units, engage the parking brake, shut off the engine, and remove the key.
2. Remove the access panel from the side of the control arm.
3. Locate the wire harness and connectors near the controller.
4. Carefully unplug the loop-back connector from the harness connector.
5. Connect the Diagnostic ACE connector to the harness connector.

**Note:** Make sure that the correct overlay decal is positioned on the Diagnostic ACE.

6. Turn the key switch to the ON position, but do not start the machine.

**Note:** The red text on the overlay decal refers to input switches and the green text refers to outputs.

7. The “outputs displayed” LED, on lower right column of Diagnostic ACE, should be illuminated. If the “inputs displayed” LED is illuminated, press the toggle button, on the Diagnostic ACE, to change the LED to “outputs displayed”.

**Note:** It may be necessary to toggle between “inputs displayed” and “outputs displayed” several times to do the following step. To toggle back and forth, press the toggle button once. This may be done as often as required. Do not hold the button.

8. Sit on the seat and attempt to operate the desired function of the machine. The appropriate output LEDs should illuminate to indicate that the ECM is turning on that function.

**Note:** If the correct output LEDs do not illuminate, verify that the required input switches are in the necessary positions to allow that function to occur. Verify correct switch function. If the output LEDs are on as specified, but the machine does not function properly, this indicates a non-electrical problem. Repair as necessary.

**Note:** If each output switch is in the correct position and functioning correctly, but the output LEDs are not correctly illuminated, this indicates an ECM problem. If this occurs, contact your Toro distributor for assistance.

**Important:** The Diagnostic ACE display must not be left connected to the machine. It is not designed to withstand the environment

of the everyday use of the machine. When you are finished using the Diagnostic ACE, disconnect it from the machine and connect the loop-back connector to the harness connector. The machine does not operate without the loop-back connector installed on the harness. Store the Diagnostic ACE in a dry, secure location in the shop, not on the machine.

## After Operation Safety

- Clean grass and debris from the cutting units, mufflers, and engine compartment to help prevent fires. Clean up oil or fuel spills.
- If the cutting units are in the transport position, use the positive mechanical lock (if available) before you leave the machine unattended.
- Allow the engine to cool before storing the machine in any enclosure.
- Shut off the fuel before storing or transporting the machine.
- Never store the machine or fuel container where there is an open flame, spark, or pilot light, such as on a water heater or on other appliances.
- Keep all parts of the machine in good working condition and all hardware tightened, especially blade-attachment hardware.
- Replace all worn or damaged decals.

## Identifying the Tie-Down Points

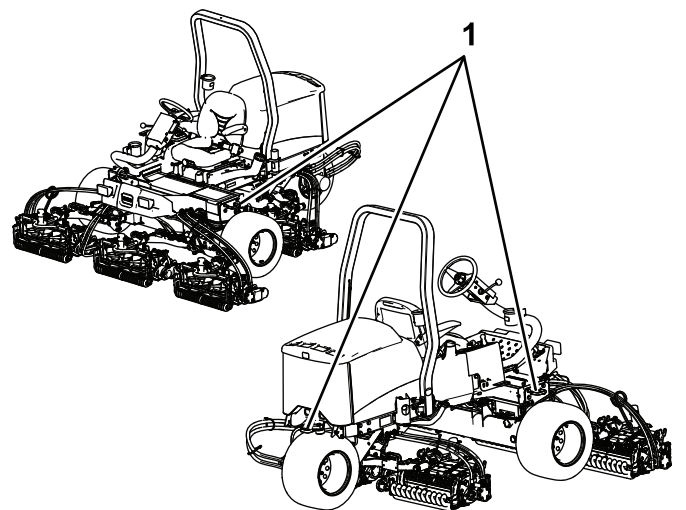

Figure 40

g198911

1. Tie-down loops

## Hauling the Machine

- Use full-width ramps for loading the machine onto a trailer or truck.
- Tie the machine down securely.

## Towing the Machine

In case of an emergency, you can tow the machine for a short distance; however, Toro does not recommend this as a standard procedure.

**Important:** Do not tow the machine faster than 3 to 4 km/h (2 to 3 mph) because the drive system may become damaged. If you must move the machine farther than 1 km (0.6 mile), transport it on a truck or trailer.

1. Locate the bypass valve on the pump (Figure 41) and rotate it 90°.

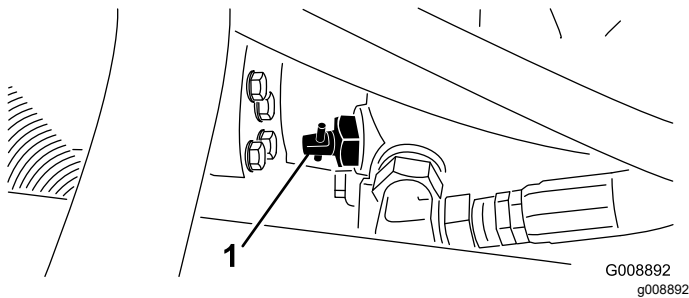

Figure 41

1. Bypass valve
2. Before starting the engine, close the bypass valve by rotating it 90° (1/4 turn).

**Important:** Do not start the engine when the valve is open.

## Operating Tips

### General Tips

### Becoming Familiar with the Machine

Before mowing grass, practice operating the machine in an open area. Start and shut off the engine. Operate in forward and reverse. Lower and raise the cutting units and engage and disengage the reels. When you feel familiar with the machine, practice operating up and down slopes at different speeds.

## ⚠ DANGER

Operating the machine without using the seat belt could result in serious personal injury or death.

Always use the seat belt.

## Understanding the Warning System

If a warning light comes on during operation, stop the machine immediately and correct the problem before continuing operation. Serious damage could occur if you operate the machine with a malfunction.

## Mowing Grass

Start the engine and move the throttle to the FAST position. Move the Enable/Disable switch to the ENABLE position and use the Lower Mow/Raise lever to control the cutting units (the front cutting units are timed to lower before the rear cutting units). To move forward and cut grass, press the traction pedal forward.

## Driving the Machine in Transport Mode

Move the Enable/Disable switch to the DISABLE position and raise the cutting units to the transport position. Move the Mow/Transport lever to the TRANSPORT position. Be careful when driving between objects so that you do not accidentally damage the machine or the cutting units. Use extra care when operating the machine on slopes. Drive slowly and avoid sharp turns on slopes to prevent roll-overs.

# Maintenance

**Note:** Determine the left and right sides of the machine from the normal operating position.

## Recommended Maintenance Schedule(s)

Maintenance Service Interval	Maintenance Procedure
After the first hour	<ul style="list-style-type: none"> <li>• Torque the wheel nuts.</li> </ul>
After the first 10 hours	<ul style="list-style-type: none"> <li>• Torque the wheel nuts.</li> <li>• Check the condition and tension of all belts.</li> <li>• Change the hydraulic filter.</li> </ul>
After the first 50 hours	<ul style="list-style-type: none"> <li>• Change the oil and oil filter.</li> </ul>
Before each use or daily	<ul style="list-style-type: none"> <li>• Check the engine-oil level.</li> <li>• Check the engine-coolant level.</li> <li>• Check the hydraulic-fluid level.</li> <li>• Check the tire pressure.</li> <li>• Check the parking brake.</li> <li>• Check the interlock system.</li> <li>• Drain the water separator.</li> <li>• Clean debris off of the radiator.</li> <li>• Check the hydraulic lines and hoses.</li> </ul>
Every 25 hours	<ul style="list-style-type: none"> <li>• Check the electrolyte level (if machine is in storage, check every 30 days).</li> </ul>
Every 50 hours	<ul style="list-style-type: none"> <li>• Lubricate all bearings and bushings (daily when conditions are dusty and dirty).</li> </ul>
Every 100 hours	<ul style="list-style-type: none"> <li>• Check the condition and tension of all belts.</li> </ul>
Every 150 hours	<ul style="list-style-type: none"> <li>• Change the oil and oil filter.</li> </ul>
Every 200 hours	<ul style="list-style-type: none"> <li>• Torque the wheel nuts.</li> <li>• Service the air cleaner (more frequently in extremely dusty or dirty conditions).</li> <li>• Check the adjustment of the parking brake.</li> <li>• Change the hydraulic filter.</li> </ul>
Every 400 hours	<ul style="list-style-type: none"> <li>• Check the fuel lines and connections.</li> <li>• Replace the fuel filter canister.</li> <li>• Service the parking brakes.</li> <li>• Change the hydraulic fluid.</li> </ul>
Every 2 years	<ul style="list-style-type: none"> <li>• Drain and clean the fuel tank.</li> </ul>

### **▲ CAUTION**

**If you leave the key in the switch, someone could accidentally start the engine and seriously injure you or other bystanders.**

**Remove the key from the switch before you do any maintenance.**



# Daily Maintenance Checklist

Duplicate this page for routine use.

Maintenance Check Item	For the week of:						
	Mon.	Tues.	Wed.	Thurs.	Fri.	Sat.	Sun.
Check the safety interlock operation.							
Check the brake operation.							
Check the engine-oil level.							
Check the cooling system fluid level.							
Drain the water/fuel separator.							
Check the air filter, dust cup, and burp valve.							
Check for unusual engine noises. <sup>1</sup>							
Check the radiator for debris.							
Check for unusual operating noises.							
Check the hydraulic system fluid level.							
Check the hydraulic hoses for damage.							
Check for fluid leaks.							
Check the fuel level.							
Check the tire pressure.							
Check the instrument operation.							
Check the height-of-cut adjustment.							
Lubricate all the grease fittings. <sup>2</sup>							
Touch-up any damaged paint.							
<sup>1</sup> Check the glow plug and injector nozzles if starting is hard, there is excess smoke, or rough running is noted. <sup>2</sup> Immediately <b>after every</b> washing, regardless of the interval listed.							

**Important:** Refer to your engine owner's manual for additional maintenance procedures.

**Note:** To obtain an electrical schematic or a hydraulic schematic for your machine, visit [www.Toro.com](http://www.Toro.com).

## Notation for Areas of Concern

Inspection performed by:		
Item	Date	Information

# Service Interval Chart

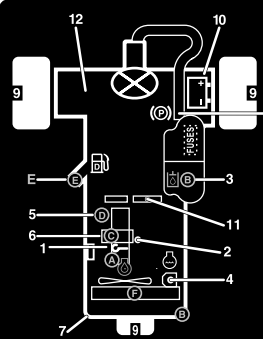

## REELMASTER 3550-D

### QUICK REFERENCE AID

CHECK/SERVICE (DAILY)

1. OIL LEVEL, ENGINE
2. ENGINE OIL DRAIN
3. OIL LEVEL HYDRAULIC TANK
4. COOLANT LEVEL, RADIATOR
5. FUEL/WATER SEPARATOR
6. AIR CLEANER
7. RADIATOR SCREEN
8. PARKING BRAKE
9. TIRE PRESSURE (12 psi)
10. BATTERY
11. BELTS (FAN, ALTERNATOR, HYDRAULIC PUMP)
12. REEL SPEED & BACKLAP CONTROL

GREASING - SEE OPERATOR'S MANUAL

#### FLUID SPECIFICATIONS/CHANGE INTERVALS

SEE OPERATOR'S MANUAL FOR INITIAL CHANGES.	FLUID TYPE	CAPACITY	CHANGE INTERVAL		FILTER PART NO.
			FLUID	FILTER	
A. ENGINE OIL	SAE 15W-40 CH-4	4.0 QTS.*	150 HRS.	150 HRS.	108-3841
B. HYD. CIRCUIT OIL	ISO VG 46/68	6 GAL.*	400 HRS.	200 HRS.	86-3010
C. AIR CLEANER				200 HRS.	108-3811
D. WATER SEPARATOR				400 HRS.	110-9049
E. FUEL TANK	NO. 2-DIESEL	7.5 GALS.	DRAIN AND FLUSH, 2 YRS.		
F. COOLANT	50/50 ETHYLENE GLYCOL/WATER	6 QTS.	DRAIN AND FLUSH, 2 YRS.		

\* INCLUDING FILTER

#### FUSES

TEC-0002	⚡	⚡	⚡
2A	7.5A	7.5A	7.5A
15A	10A	10A	10A

Figure 42

decal120-2102

## Pre-Maintenance Procedures

## Pre-Maintenance Safety

- Before adjusting, cleaning, repairing, or leaving the machine, do the following:
  - Park the machine on a level surface.
  - Move the throttle switch to the low-idle position.
  - Disengage the cutting units.
  - Lower the cutting units.
  - Ensure that the traction is in neutral.
  - Engage the parking brake.
  - Shut off the engine and remove the key.
  - Wait for all moving parts to stop.
  - Allow machine components to cool before performing maintenance.
- If the cutting units are in the transport position, use the positive mechanical lock (if available) before you leave the machine unattended.
- If possible, do not perform maintenance while the engine is running. Keep away from moving parts.
- Use jack stands to support the machine or components when required.
- Carefully release pressure from components with stored energy.

## Removing the Hood

The hood may be easily removed to ease maintenance procedures in the engine area of the machine.

1. Unlatch and raise the hood.
2. Remove the hairpin cotter securing the hood pivot to the mounting brackets (Figure 43).

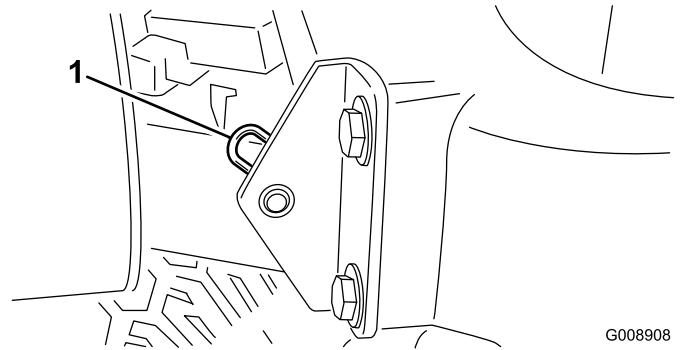

Figure 43

G008908  
g008908

1. Hairpin cotter
3. Slide the hood to the right side, lift the other side, and pull it out of the brackets.

**Note:** Reverse the procedure to install the hood.

# Removing the Battery Cover

Loosen the knobs and remove the battery cover (Figure 44).

**Note:** Refer to [Servicing the Battery \(page 40\)](#) for more information.

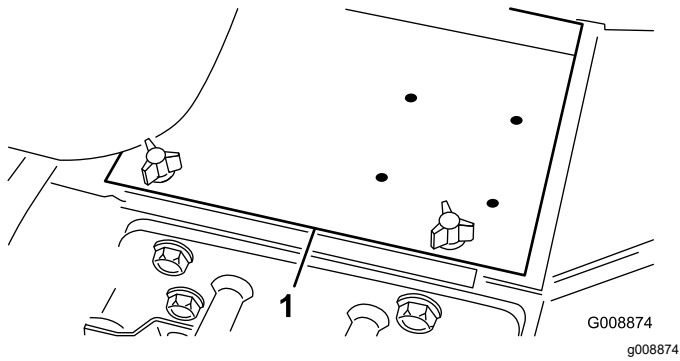

**Figure 44**

1. Battery cover
-

# Lubrication

## Greasing the Bearings and Bushings

**Service Interval:** Every 50 hours (daily when conditions are dusty and dirty).

Park the machine on a level surface, lower the cutting units, engage the parking brake, shut off the engine, and remove the key from the ignition switch.

Lubricate the grease fittings regularly with No. 2 lithium grease. Lubricate the bearings and bushings daily when operating conditions are extremely dusty and dirty. Dusty and dirty operating conditions could cause dirt to get into the bearings and bushings, resulting in accelerated wear. Lubricate the grease fittings immediately after every washing, regardless of the interval specified.

The grease fitting locations and quantities are as follows:

- Steering pivot (Figure 45)

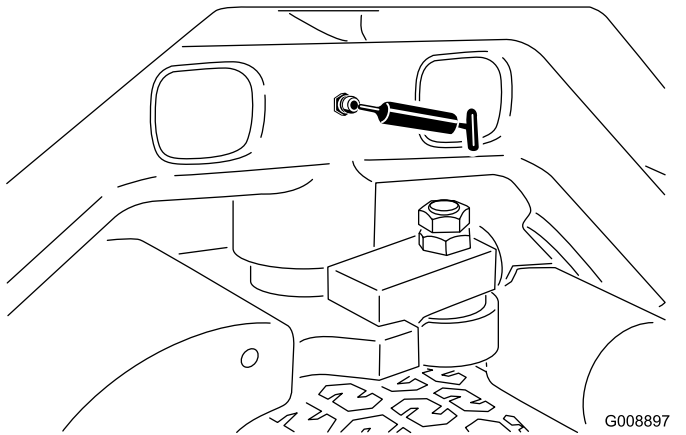

Figure 45

- Front lift-arm pivots and lift cylinders (3 each); refer to Figure 46.

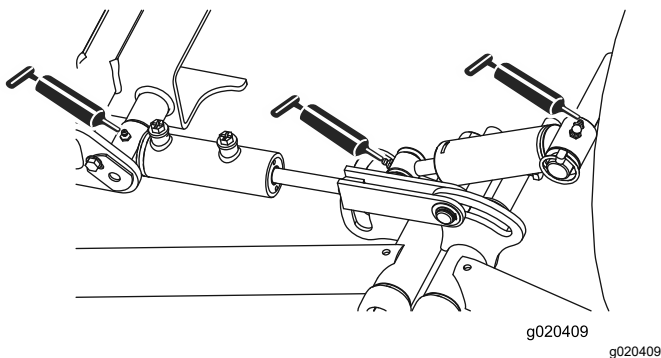

Figure 46

- Rear lift-arm pivots and lift cylinders (3 each side); refer to Figure 47.

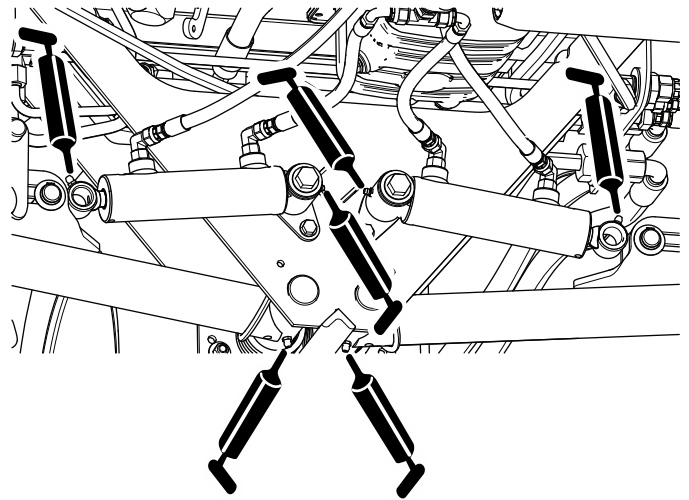

Figure 47

g200803

- Cutting unit pivots (2 each); refer to Figure 48.

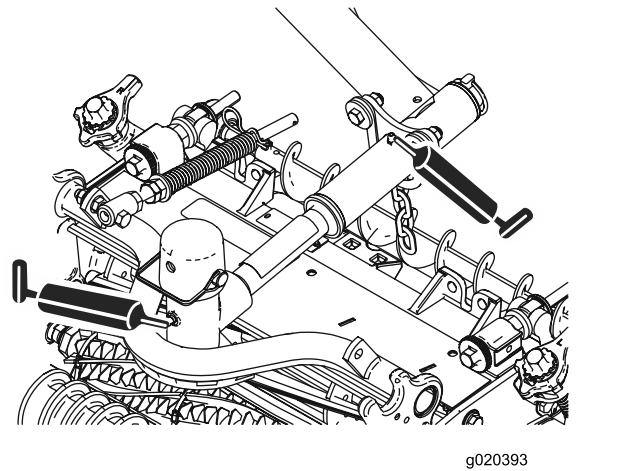

Figure 48

- Neutral adjust mechanism (Figure 49)

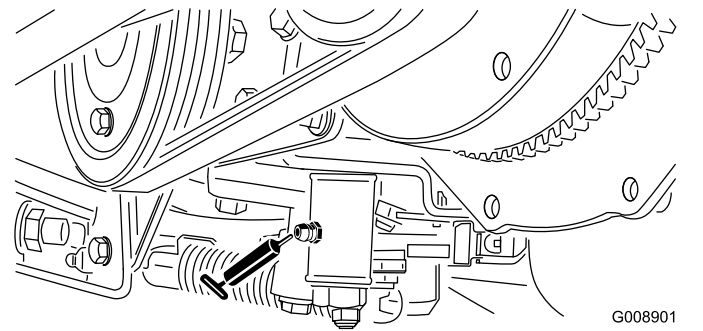

Figure 49

- Mow/transport slide (Figure 50)

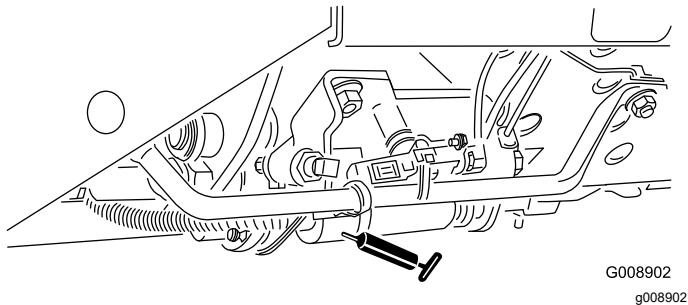

Figure 50

G008902  
g008902

- Belt tension pivot (Figure 51)

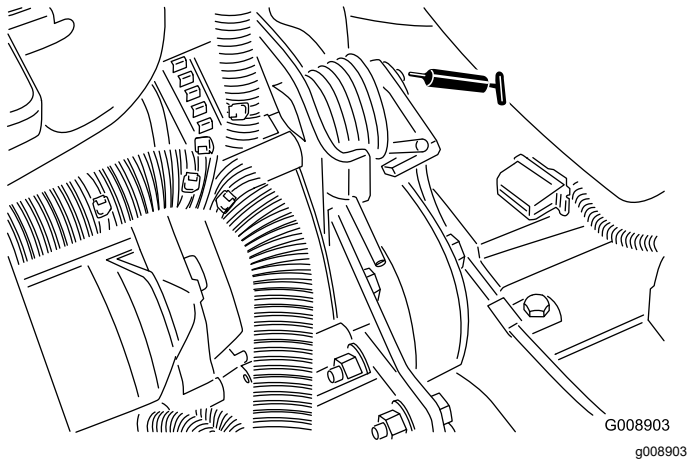

Figure 51

G008903  
g008903

# Engine Maintenance

## Engine Safety

- Shut off the engine before checking the oil or adding oil to the crankcase.
- Do not change the governor speed or overspeed the engine.

## Servicing the Air Cleaner

**Service Interval:** Every 200 hours (more frequently in extremely dusty or dirty conditions).

- Check the air-cleaner body for damage which could cause an air leak. Replace it if it is damaged. Check the whole intake system for leaks, damage, or loose hose clamps.
  - Service the air cleaner at the recommended service interval or earlier if engine performance suffers due to extremely dusty, dirty conditions. Changing the air filter before it is necessary only increases the chance of dirt entering the engine when you remove the filter.
  - Be sure that the cover is seated correctly and seals with the air-cleaner body.
1. Park the machine on a level surface, lower the cutting units, engage the parking brake, shut off the engine, and remove the key.
  2. Release the latches securing the air-cleaner cover to the air-cleaner body (Figure 52).
  3. Remove the cover from the air-cleaner body (Figure 52).
  4. Before removing the filter, use low-pressure air (276 kPa [40 psi], clean and dry) to help remove large accumulations of debris packed between outside of primary filter and the canister.
 

**Note:** Avoid using high-pressure air, which could force dirt through the filter into the intake tract. This cleaning process prevents debris from migrating into the intake when you remove the primary filter.
  5. Remove and replace the filter (Figure 52).
 

Do not clean the used element because it could damage the filter media.

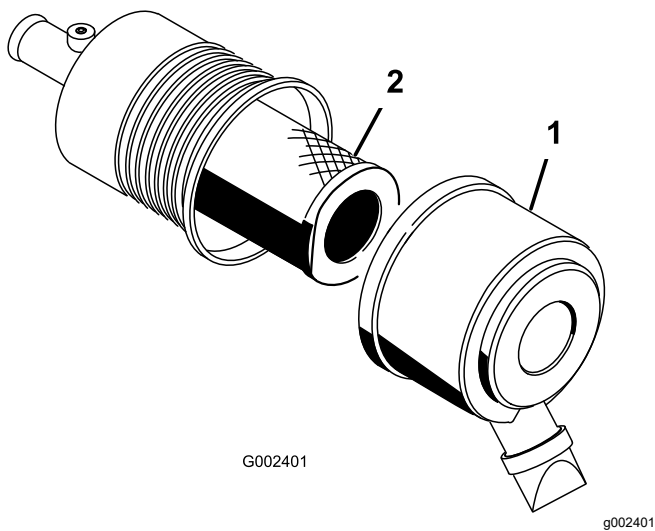

G002401

g002401

**Figure 52**

1. Air-cleaner cover
2. Filter

6. Inspect the new filter for shipping damage, checking the sealing end of the filter and the body.
7. Insert the new filter by applying pressure to the outer rim of the element to seat it in the canister.

**Important:** Do not use a damaged element.

**Important:** Do not apply pressure to the flexible center of the filter.

8. Clean the dirt-ejection port located in the removable cover.
9. Remove the rubber outlet valve from the cover, clean the cavity and replace the outlet valve.
10. Install the cover orienting the rubber outlet valve in a downward position—between approximately 5 o'clock to 7 o'clock when viewed from the end.
11. Secure the cover latches.

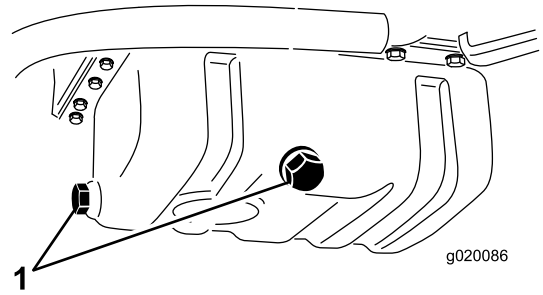

g020086

g020086

**Figure 53**

1. Engine-oil drain plugs

3. Remove the oil filter ([Figure 54](#)).

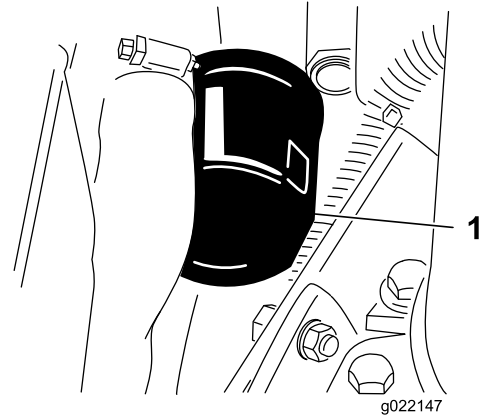

g022147

g022147

**Figure 54**

1. Engine oil filter

4. Apply a light coat of clean oil to the new filter seal, and install the filter.

**Important:** Do not overtighten the filter.

5. Add oil to the crankcase; refer to [Checking the Engine-Oil Level](#) (page 19).

## Changing the Engine Oil and Filter

**Service Interval:** After the first 50 hours

Every 150 hours

1. Park the machine on a level surface, lower the cutting units, engage the parking brake, shut off the engine, and remove the key.
2. Remove either drain plug ([Figure 53](#)) and let the oil flow into a drain pan. When the oil stops flowing, install the drain plug.

# Fuel System Maintenance

## Servicing the Fuel Tank

**Service Interval:** Every 2 years—Drain and clean the fuel tank.

Park the machine on a level surface, lower the cutting units, engage the parking brake, shut off the engine, and remove the key.

Drain and clean the tank if the fuel system becomes contaminated or if the machine will be stored for an extended period of time. Use clean fuel to flush out the tank.

## Inspecting the Fuel Lines and Connections

**Service Interval:** Every 400 hours/Yearly (whichever comes first)

Park the machine on a level surface, lower the cutting units, engage the parking brake, shut off the engine, and remove the key from the ignition switch.

Inspect the fuel lines and connections for deterioration, damage, or loose connections.

## Draining the Water Separator

**Service Interval:** Before each use or daily

1. Park the machine on a level surface, lower the cutting units, engage the parking brake, shut off the engine, and remove the key from the ignition switch.
2. Place a clean container under the fuel filter.
3. Loosen the drain valve on the bottom of the filter canister ([Figure 55](#)).

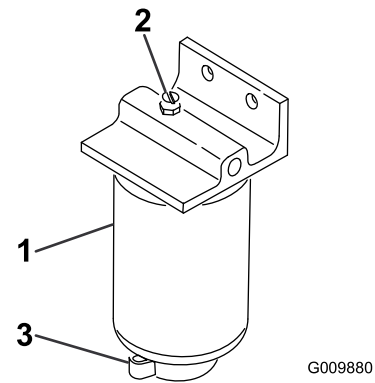

**Figure 55**

1. Water separator/filter canister
2. Vent plug
3. Drain valve

4. Tighten the valve after draining.

## Changing the Fuel Filter Canister

**Service Interval:** Every 400 hours

1. Park the machine on a level surface, lower the cutting units, engage the parking brake, shut off the engine, and remove the key from the ignition switch.
2. Clean the area where the filter canister mounts ([Figure 55](#)).
3. Remove the filter canister and clean the mounting surface.
4. Lubricate the gasket on the filter canister with clean oil.
5. Install the filter canister by hand until the gasket contacts the mounting surface; then rotate it an additional 1/2 turn.

## Bleeding Air from the Injectors

**Note:** Use this procedure only if the fuel system has been purged of air through normal priming procedures and the engine does not start; refer to [Bleeding the Fuel System \(page 27\)](#).

1. Park the machine on a level surface, lower the cutting units, engage the parking brake, and shut off the engine.
2. Loosen the pipe connection to the No. 1 nozzle and holder assembly.

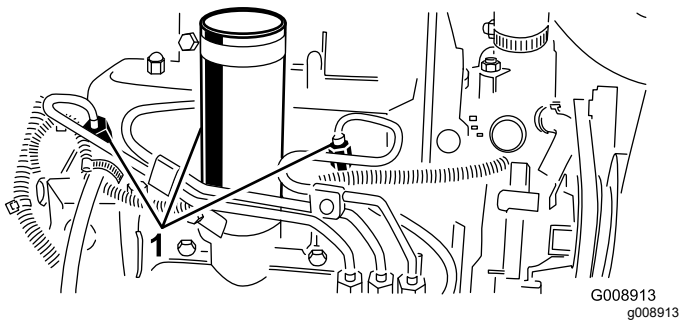

**Figure 56**

1. Fuel injectors

- 
3. Move the throttle to the FAST position.
  4. Turn the key in the key switch to the START position and watch the fuel flow around the connector. Turn the key to the OFF position when there is a continuous flow.
  5. Tighten the pipe connector securely.
  6. Repeat the procedure on the remaining nozzles.

# Electrical System Maintenance

## Electrical System Safety

- Disconnect the battery before repairing the machine. Disconnect the negative terminal first and the positive last. Connect the positive terminal first and the negative last.
- Charge the battery in an open, well-ventilated area, away from sparks and flames. Unplug the charger before connecting or disconnecting the battery. Wear protective clothing and use insulated tools.

### **WARNING**

#### **CALIFORNIA Proposition 65 Warning**

**Battery posts, terminals, and related accessories contain lead and lead compounds, chemicals known to the State of California to cause cancer and reproductive harm. Wash hands after handling.**

## Servicing the Battery

**Service Interval:** Every 25 hours—Check the electrolyte level (if machine is in storage, check every 30 days).

Park the machine on a level surface, lower the cutting units, engage the parking brake, shut off the engine, and remove the key from the ignition switch.

Maintain the battery electrolyte level and keep the top of the battery clean. Store the machine where the temperature is cooler rather than warmer to prevent the battery from discharging more rapidly.

Maintain the cell level with distilled or demineralized water. Do not fill the cells above the bottom of the split ring inside each cell. Install the filler caps with the vents pointing to the rear (toward the fuel tank).



## **⚠ DANGER**

Battery electrolyte contains sulfuric acid which is fatal if consumed and causes severe burns.

- Do not drink electrolyte and avoid contact with skin, eyes, or clothing. Wear eye protection to shield your eyes and rubber gloves to protect your hands.
- Fill the battery where clean water is always available for flushing the skin.

Keep the top of the battery clean by washing it periodically with a brush dipped in ammonia or bicarbonate of soda solution. Flush the top surface with water after cleaning. Do not remove the filler caps while cleaning.

The battery cables must be tight on the terminals to provide good electrical contact.

## **⚠ WARNING**

Incorrect battery cable routing could damage the tractor and cables causing sparks. Sparks can cause the battery gasses to explode, resulting in personal injury.

- Always disconnect the negative (black) battery cable before disconnecting the positive (red) cable.
- Always connect the positive (red) battery cable before connecting the negative (black) cable.

If corrosion occurs at the terminals, disconnect the cables, negative (–) cable first, and scrape the clamps and terminals separately. Connect the cables, positive (+) cable first, and coat the terminals with petroleum jelly.

## Checking the Fuses

The fuses in the electrical system are located under the control panel.

# Drive System Maintenance

## Adjusting the Traction Drive for Neutral

If the machine moves when the traction pedal is in the NEUTRAL position, adjust the traction cam.

1. Park the machine on a level surface, lower the cutting units, engage the parking brake, shut off the engine, and remove the key from the ignition switch.
2. Raise a front wheel and a rear wheel off the floor and place support blocks under the frame.

## **⚠ WARNING**

If the machine is not supported adequately, it may accidentally fall, injuring anyone under the machine.

A front wheel *and* a rear wheel must be raised off the ground; otherwise, the machine will move during adjustment.

3. Loosen the locknut on the traction adjustment cam (Figure 57).

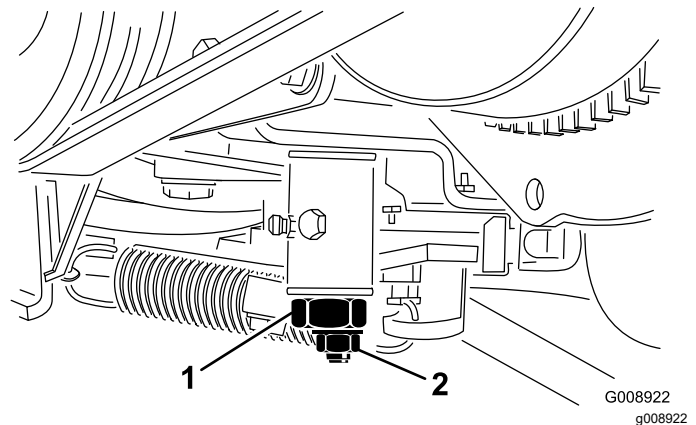

Figure 57

1. Traction adjustment cam
2. Locknut

## **⚠ WARNING**

The engine must be running so that you can make a final adjustment of the traction adjustment cam. Contact with hot or moving parts can result in personal injury.

**Keep your hands, feet, face, and other body parts away from the muffler, other hot parts of the engine, and rotating parts.**

4. Start the engine and rotate the cam hex in both directions to determine the mid position of the neutral span.
5. Tighten the locknut securing the adjustment.
6. Shut off the engine.
7. Remove the support blocks and lower the machine to the shop floor. Test drive the machine to ensure that it does not move when the traction pedal is in neutral.

# Cooling System Maintenance

## Cooling System Safety

- Swallowing engine coolant can cause poisoning; keep it out of reach of children and pets.
- Discharge of hot, pressurized coolant or touching a hot radiator and surrounding parts can cause severe burns.
  - Always allow the engine to cool at least 15 minutes before removing the radiator cap.
  - Use a rag when opening the radiator cap, and open the cap slowly to allow steam to escape.

## Cleaning the Engine Cooling System

**Service Interval:** Before each use or daily

Remove debris from the radiator daily. Clean it more frequently in dirty conditions.

1. Park the machine on a level surface, lower the cutting units, engage the parking brake, shut off the engine, and remove the key from the ignition switch.
2. Raise the hood.
3. Clean the engine area thoroughly of all debris.
4. Clean both sides of the radiator thoroughly with compressed air (Figure 58).

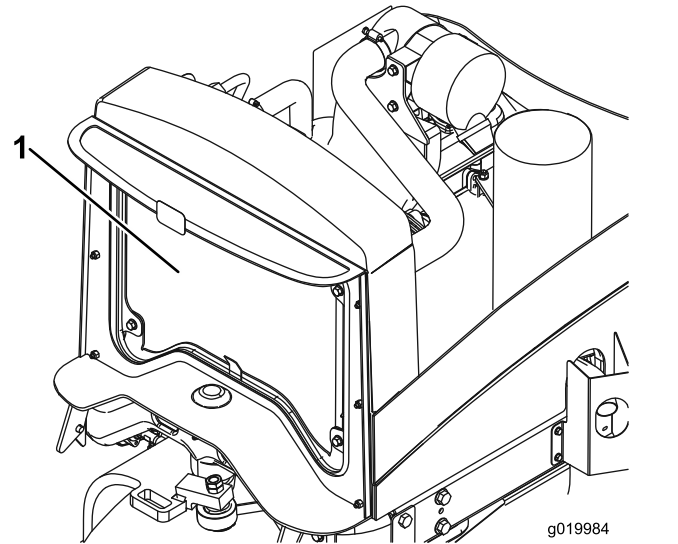

**Figure 58**

1. Radiator

- 
5. Close the hood.

# Brake Maintenance

## Adjusting the Parking Brake

**Service Interval:** Every 200 hours—Check the adjustment of the parking brake.

1. Park the machine on a level surface, lower the cutting units, engage the parking brake, shut off the engine, and remove the key from the ignition switch.
2. Loosen the setscrew securing the knob to the parking-brake lever (Figure 59).

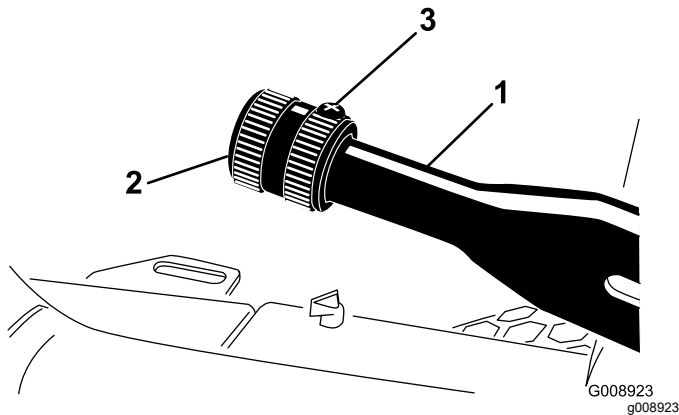

Figure 59

1. Parking-brake lever
2. Knob
3. Set screw

3. Rotate the knob until a force of 133 to 178 N (30 to 40 lb) is required to actuate the lever.
4. Tighten the setscrew after the adjustment has been attained.

## Servicing the Parking Brakes

**Service Interval:** Every 400 hours

### Preparing the Machine

1. Park machine on a level surface, engage parking brake, lower cutting units, shut off the engine, remove the key, and wait for all moving parts to stop before leaving the operator's seat.
2. Raise the front of machine.
3. Support the machine with jack stands rated for the weight of your machine; refer to [Specifications \(page 18\)](#).
4. Repeat steps 2 and 3 at the other side of the machine.

## Removing the Front Wheels

1. Remove the 4 lug nuts that secure the front wheel to the hub, and remove the wheel (Figure 60).

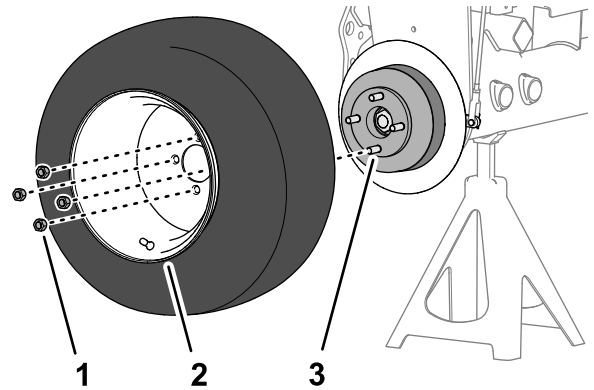

Figure 60

1. Lug nut
2. Wheel
3. Hub

2. Repeat step 1 at the other side of the machine.

## Removing the Wheel Hub and Brake Drum

**Special Tools:** Wheel Hub Puller—Toro Part No. TOR4097

1. Remove the locknut that secures the hub to the wheel-motor shaft (Figure 61 or Figure 62).

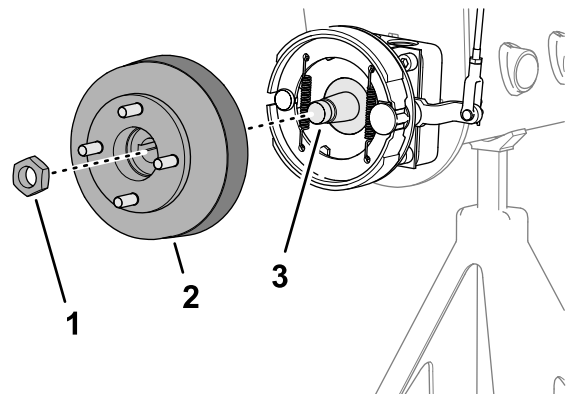
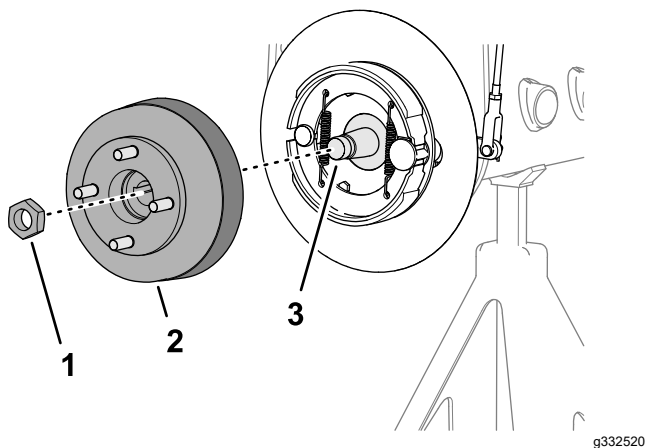

Figure 61

Machines without the Optional Grass Shield

1. Locknut
2. Hub and brake drum
3. Wheel-motor shaft

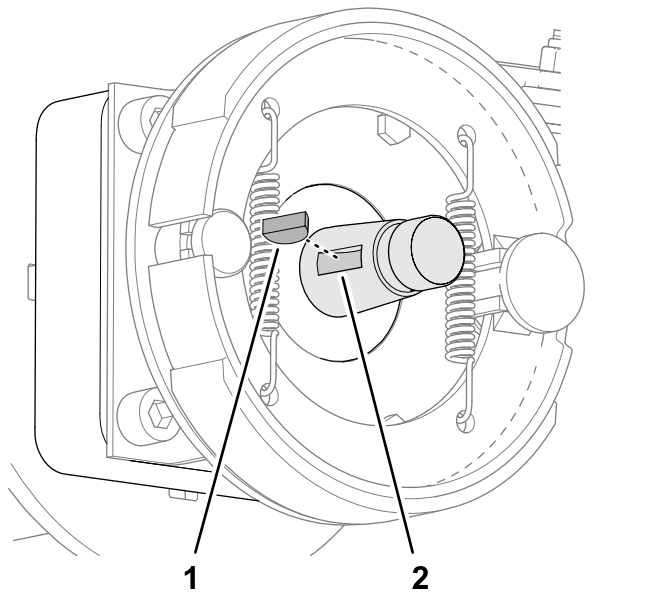

**Figure 62**

Machines with the Optional Grass Shield

1. Locknut
2. Hub and brake drum
3. Wheel-motor shaft

2. Repeat step 1 at the other side of the machine.
3. Release the parking brake.
4. Use the specified wheel hub puller to remove wheel hub and brake drum from the wheel-motor shaft (Figure 61 or Figure 62).
5. Remove woodruff key from the wheel-motor shaft (Figure 63).



**Figure 63**

1. Woodruff key
2. Groove (wheel-motor shaft)

6. Repeat steps 4 and 5 at the other side of the machine.

## Cleaning the Brake Drum and Shoes

At both sides of the machine, clean inside the brake drums, the brake shoes, backing plate (Figure 64), and when installed, the optional grass shield of any grass, dirt, and dust.

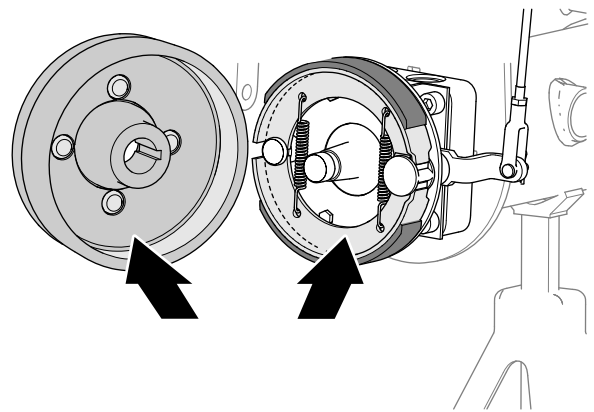

**Figure 64**

## Inspecting and Lubricating the Brake Cam Shaft

1. At the inboard side of the brake-backing plate (machines without the optional wheel-rim grass shield) or the wheel shield (machines with the optional wheel-rim grass shield), spray penetrating oil between the brake cam shaft and the backing plate (Figure 65 or Figure 66).

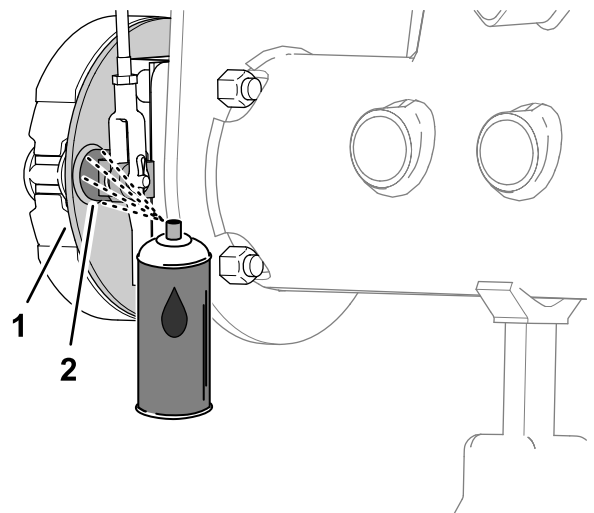

**Figure 65**

Machines without the Optional Grass Shield

1. Backing plate
2. Brake cam shaft

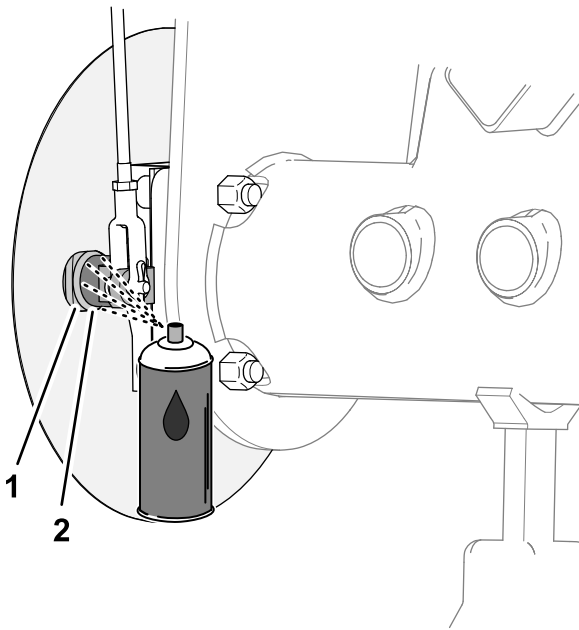

**Figure 66**

Machines with the Optional Grass Shield

g332545

1. Backing plate
2. Brake cam shaft

2. Move the parking brake lever up and down to check that the lever for the brake-cam lever moves freely (Figure 67).

**Note:** If the brake cam binds, repair or replace the brake cam; refer to the *Service Manual* for your machine.

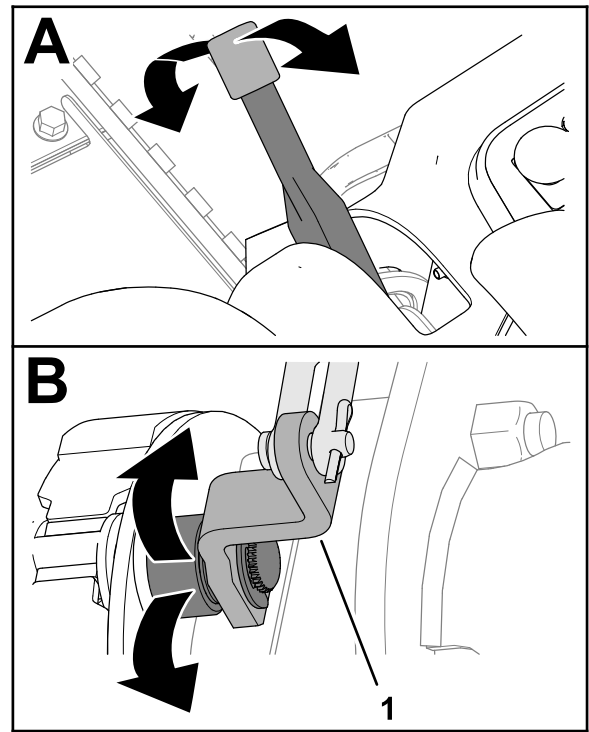

**Figure 67**

g332560

1. Brake-cam lever

3. Repeat steps 1 and 2 at the other side of the machine.
4. Move the parking brake lever down (the disengaged position).

## Inspecting the Brake Linkage

1. Inspect the left and right brake-rod assemblies (Figure 68) for damage and wear.

**Note:** If the brake rod parts are damaged and worn, replace them; refer to the *Service Manual* for your machine.

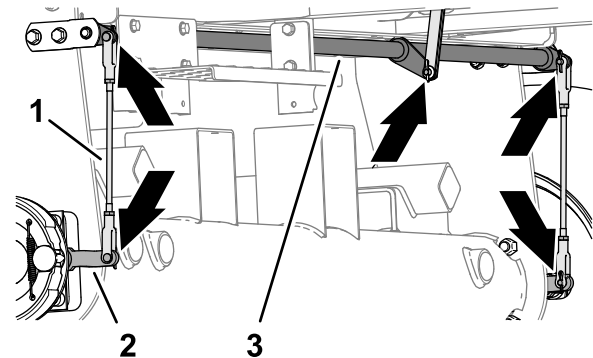

**Figure 68**

g332541

1. Brake-rod assemblies
2. Brake-cam lever
3. Brake pivot shaft

2. Inspect the brake pivot shaft (Figure 68) for damage and wear.

If the pivot shaft is damaged and worn, replace them; refer to the *Service Manual* for your machine.

## Installing the Wheel Hub and Brake Drum

1. Thoroughly clean the wheel hub and hydraulic motor shaft.
2. Insert the woodruff key into the groove of the wheel-motor shaft (Figure 69).

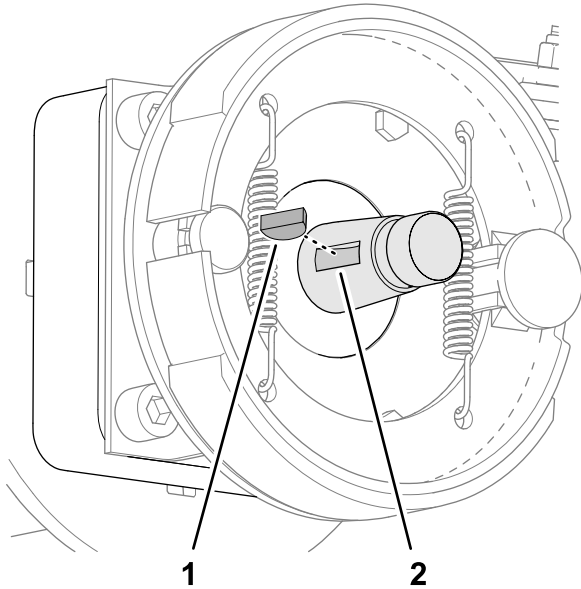

Figure 69

g332521

1. Woodruff key
2. Groove (wheel-motor shaft)

3. Assemble the wheel hub and brake drum onto the wheel-motor shaft (Figure 70 or Figure 71).

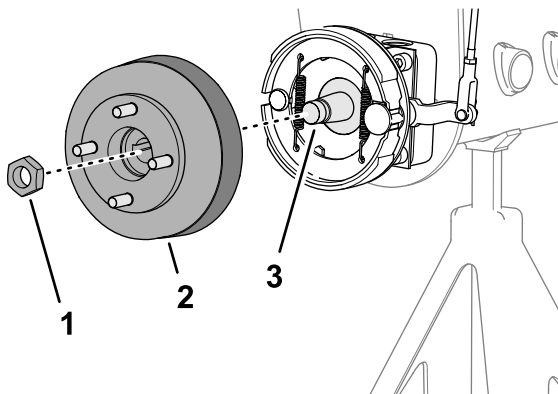
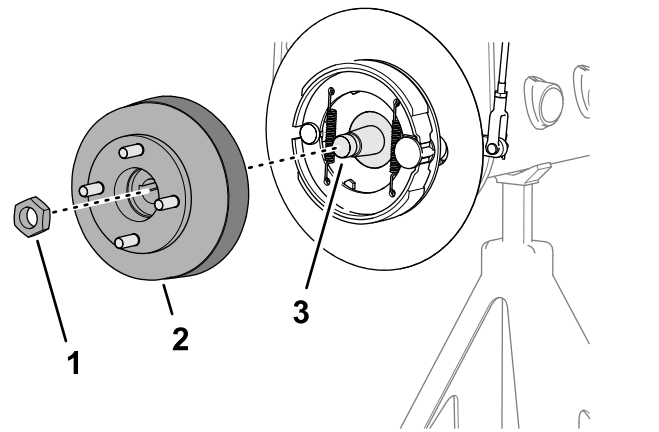

Figure 70

g332519

Machines without the Optional Grass Shield

1. Locknut
2. Hub and brake drum
3. Wheel-motor shaft



g332520

Figure 71

Machines with the Optional Grass Shield

1. Locknut
2. Hub and brake drum
3. Wheel-motor shaft

4. Secure the wheel hub to the shaft with the locknut (Figure 70 or Figure 71), and tighten by hand.

**Note:** The brake shoes and backing plate must concentrically align with the brake drum. If the shoes, plate, and drum are misaligned, refer to the *Service Manual* for your machine.

5. Repeat steps 1 through 4 at the other side of the machine.

## Installing the Wheel

1. Assemble the wheel to the hub with the 4 lug nuts (Figure 72), and tighten the lug nuts by hand.

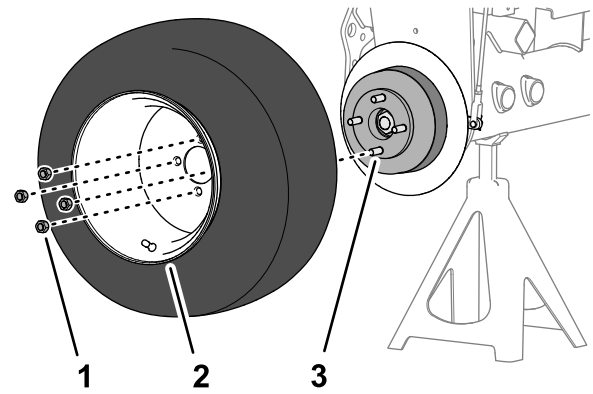

g332518

Figure 72

1. Lug nut
2. Wheel
3. Hub

2. Repeat step 1 at the other side of the machine.
3. Remove the jack stands and lower the machine.
4. Torque wheel lug nuts to 95 to 122·Nm (70 to 90 ft·lb) in a crossing pattern.



5. Torque the locknut is to 339 to 372 N·m (250 to 275 ft-lb).
6. Check parking brake and adjust it if necessary; refer to [Checking the Parking Brake \(page 23\)](#).

## Belt Maintenance

### Servicing the Engine Belts

**Service Interval:** After the first 10 hours—Check the condition and tension of all belts.

Every 100 hours—Check the condition and tension of all belts.

### Tensioning the Alternator/Fan Belt

1. Park the machine on a level surface, lower the cutting units, engage the parking brake, shut off the engine, and remove the key from the ignition switch.
2. Open the hood.
3. Check the belt tension by pressing the belt midway between the alternator and crankshaft pulleys.

**Note:** With 98 N (22 lb) of force, the belt should deflect 11 mm (7/16 inch).

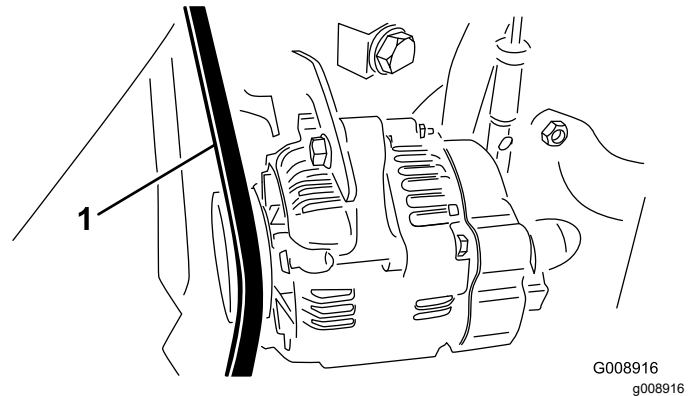

Figure 73

1. Alternator/fan belt

4. If the deflection is incorrect, complete the following procedure to tension the belt:
  - A. Loosen the bolt securing the brace to the engine and the bolt securing the alternator to the brace.
  - B. Insert a pry bar between the alternator and engine and pry the alternator outward.
  - C. When the proper tension is achieved, tighten the alternator and brace bolts to secure the adjustment.

### Replacing the Hydrostat Drive Belt

1. Park the machine on a level surface, lower the cutting units, engage the parking brake, shut off the engine, and remove the key from the ignition switch.

2. Insert a nut driver or small piece of tubing onto the end of the belt tensioning spring.

**⚠ WARNING**

The spring is under a heavy load and could cause personal injury

Use caution when de-tensioning the spring.

3. Push down and forward on the spring end (Figure 74) to unhook it from the bracket and release tension on the spring.

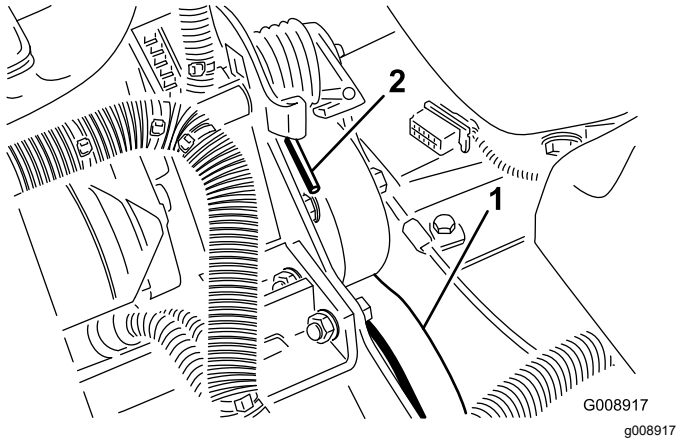

**Figure 74**

1. Hydrostat drive belt
2. Spring end

4. Replace the belt.
5. Reverse the procedure to tension the spring.

# Controls System Maintenance

## Adjusting the Throttle

1. Park the machine on a level surface, lower the cutting units, engage the parking brake, shut off the engine, and remove the key from the ignition switch.
2. Position the throttle lever rearward so that it stops against the control panel slot.
3. Loosen the throttle cable connector on the injection pump lever arm (Figure 75).

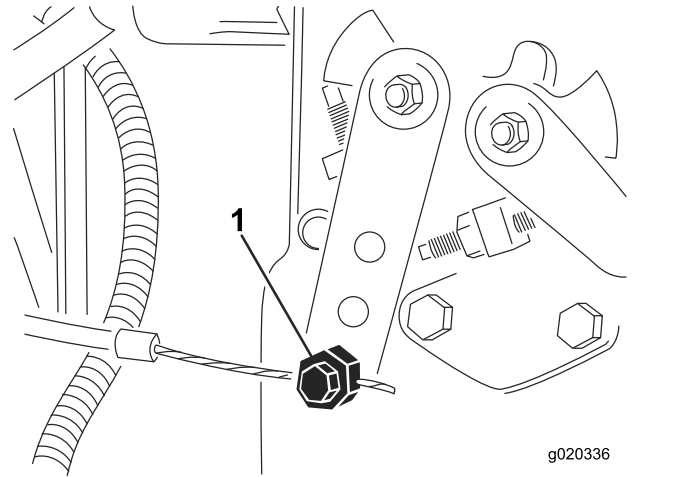

**Figure 75**

1. Injection pump lever arm
4. Hold the injection pump lever arm against the low idle stop and tighten the cable connector.
5. Loosen the screws securing the throttle control to the control panel.
6. Push the throttle control lever all of the way forward.
7. Slide the stop plate until it contacts the throttle lever and tighten the screws securing the throttle control to the control panel.
8. If the throttle does not stay in position during operation, torque the locknut, used to set the friction device on the throttle lever, to 5 to 6 N·m (44 to 53 in-lb).

**Note:** The maximum force required to operate the throttle lever should be 89 N (20 lb).



# Hydraulic System Maintenance

## Hydraulic System Safety

- Ensure that all hydraulic-fluid hoses and lines are in good condition and all hydraulic connections and fittings are tight before applying pressure to the hydraulic system.
- Keep your body and hands away from pinhole leaks or nozzles that eject high-pressure hydraulic fluid.
- Use cardboard or paper to find hydraulic leaks.
- Safely relieve all pressure in the hydraulic system before performing any work on the hydraulic system.
- Seek immediate medical attention if fluid is injected into skin. Injected fluid must be surgically removed within a few hours by a doctor.

## Changing the Hydraulic Filter

**Service Interval:** After the first 10 hours  
Every 200 hours/Yearly (whichever comes first)

Use a genuine Toro replacement filter, Part No. 86-3010.

**Important:** Use of any other filter may void the warranty on some components.

1. Park the machine on a level surface, lower the cutting units, engage the parking brake, shut off the engine, and remove the key from the ignition switch.
2. Clean around the filter mounting area. Place a drain pan under the filter ([Figure 76](#)) and remove the filter.

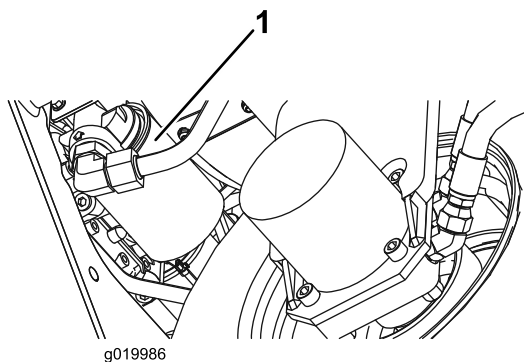

**Figure 76**

1. Hydraulic filter

3. Lubricate the new filter gasket and fill the filter with hydraulic fluid.
4. Ensure that the filter mounting area is clean. Screw the filter on until the gasket contacts the mounting plate; then tighten the filter 1/2 turn.
5. Start the engine and let it run for about 2 minutes to purge air from the system. Shut off the engine and check for leaks.

## Changing the Hydraulic Fluid

**Service Interval:** Every 400 hours

If the fluid becomes contaminated, contact your local Toro distributor because the system must be flushed. Contaminated fluid looks milky or black when compared to clean oil.

1. Park the machine on a level surface, lower the cutting units, engage the parking brake, shut off the engine, and remove the key from the ignition switch.
2. Disconnect the large hydraulic hose ([Figure 77](#)) from the reservoir and let the hydraulic fluid flow into a drain pan.

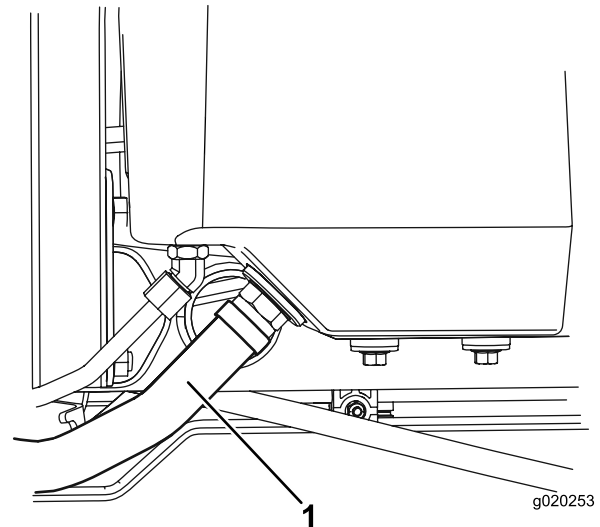
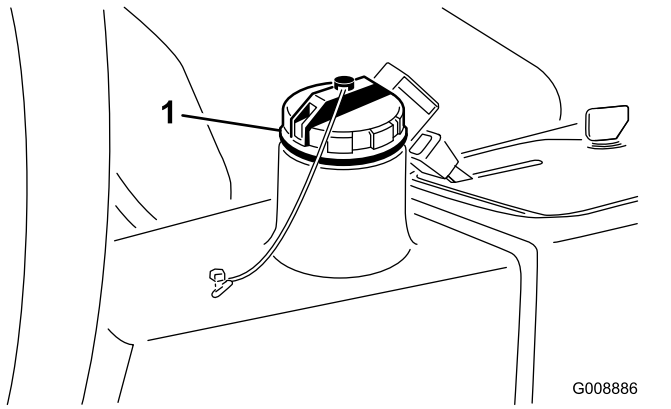

**Figure 77**

1. Hydraulic hose

3. Install the hydraulic hose when hydraulic fluid stops draining.
4. Fill the reservoir ([Figure 78](#)) with approximately 13.2 L (3.5 US gallons) of hydraulic fluid; refer to [Checking the Hydraulic System \(page 21\)](#).

**Important:** Use only the hydraulic fluids specified. Other fluids could cause system damage.



**Figure 78**

1. Hydraulic fill cap

5. Install the reservoir cap. Start the engine and use all of the hydraulic controls to distribute the hydraulic fluid throughout the system.
6. Check for leaks; then shut off the engine.
7. Check the fluid level and add enough to raise the level to Full mark on the dipstick.

**Important:** Do not overfill the reservoir.

## Checking the Hydraulic Lines and Hoses

**Service Interval:** Before each use or daily

Park the machine on a level surface, lower the cutting units, engage the parking brake, shut off the engine, and remove the key from the ignition switch.

Check the hydraulic lines and hoses for leaks, kinked lines, loose mounting supports, wear, loose fittings, weather deterioration, and chemical deterioration. Make all necessary repairs before operating the machine.

# Cutting Unit System Maintenance

## Cutting Unit Safety

A worn or damaged cutting unit can break, and a piece of a reel or bedknife could be thrown at you or bystanders, resulting in serious personal injury or death.

- Inspect the cutting units periodically for wear or damage.
- Use care when checking the cutting units. Wrap the blades or wear gloves, and use caution when servicing the reels and bedknives. Only replace or sharpen the reels and bedknives; never straighten or weld them.
- On multi-bladed machines, take care as rotating 1 reel can cause other blades to rotate.

## Using the Optional Gauge Bar

Use the gauge bar (Figure 79) to adjust the cutting unit. Refer to the cutting unit *Operator's Manual* for the adjustment procedure.

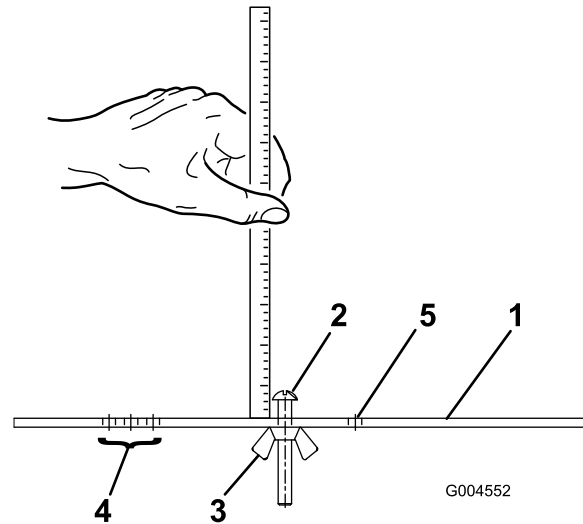

**Figure 79**

1. Gauge bar
2. Height adjusting screw
3. Nut
4. Holes used for setting groomer HOG
5. Hole not used

# Backlapping the Cutting Units

## ⚠ WARNING

Contact with the reels or other moving parts can result in personal injury.

- Keep your fingers, hands, and clothing away from the reels and other moving parts.
- Never attempt to turn the reels by hand or foot while the engine is running.

**Note:** When backlapping, all the cutting units operate together.

1. Park the machine on a level surface, lower the cutting units, engage the parking brake, shut off the engine, and move the Enable/Disable switch to the DISABLE position.
2. Raise the floor panel to expose the controls.
3. Make the initial reel-to-bedknife adjustments appropriate for backlapping; refer to the cutting unit *Operator's Manual*.
4. Start the engine and allow it to run at low idle speed.

## ⚠ DANGER

Changing the engine speed while backlapping may cause the reels to stall.

- Never change the engine speed while backlapping
  - Backlap only at idle engine speed.
5. Set the reel speed control to position 1 (Figure 80).

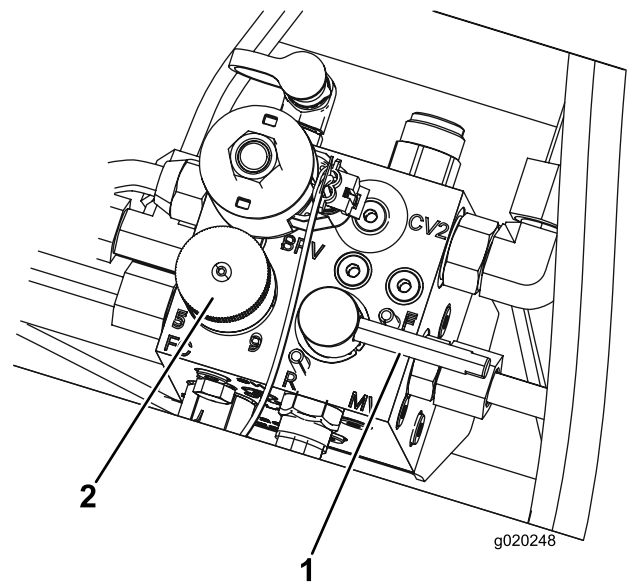

Figure 80

1. Backlap lever
2. Reel speed control knob

6. Move the backlap lever to the R (backlap) position (Figure 80).

## ⚠ DANGER

Contacting the reels when they are moving could cause personal injury.

To avoid personal injury, be certain that you are clear of the cutting units before proceeding.

7. With the Mow/Transport lever in the Mow position, move the Enable/Disable switch to the ENABLE position. Move the Lower Mow/Lift control forward to start the backlapping operation on the designated reels.
8. Apply lapping compound with a long-handle brush. Never use a short-handled brush.
9. If the reels stall or become erratic while backlapping, select a higher reel speed setting until the speed stabilizes, then return the reel speed to setting 1 or to your desired speed.
10. To make an adjustment to the cutting units while backlapping, turn the reels off by moving the Lower Mow/Raise lever rearward; the Enable/Disable switch to the DISABLE position, and shut off the engine. After completing the adjustments, repeat steps 5 through 9.
11. Repeat the procedure for all the cutting units that you want to backlap.
12. When you are finished, return the backlap lever to the MOW position, lower the floor panel, and wash all lapping compound off of the cutting units. Adjust the cutting unit reel-to-bedknife

contact as needed. Move the cutting unit reel speed control to the desired mowing position.

**Important:** If the backlap switch is not returned to the F (Mow) position after backlapping, the cutting units will not raise or function properly.

**Note:** For a better cutting edge, run a file across the front face of the bedknife after lapping. This removes any burrs or rough edges that may have built up on the cutting edge.

# Storage

## Storing the Battery

If the machine will be stored more than 30 days, remove the battery and charge it fully. Store the battery in a cool atmosphere to avoid quick deterioration of the charge in the battery. To prevent the battery from freezing, ensure that it is fully charged. The specific gravity of a fully charged battery is 1.265 to 1.299.

## Preparing the Machine for Seasonal Storage

Follow these procedures anytime you will be storing the machine for more than 30 days.

### Preparing the Traction Unit

1. Park the machine on a level surface, lower the cutting units, engage the parking brake, shut off the engine, and remove the key from the ignition switch.
2. Thoroughly clean the traction unit, the cutting units, and the engine.
3. Check the tire pressure. Inflate all tires to 83 kPa (12 psi).
4. Check all fasteners for looseness; tighten as necessary.
5. Grease or oil all grease fittings and pivot points. Wipe up any excess lubricant.
6. Lightly sand and use touch-up paint on painted areas that are scratched, chipped, or rusted. Repair any dents in the metal body.
7. Service the battery and cables as follows:
  - A. Remove the battery terminals from the battery posts.
  - B. Remove the battery.
  - C. Slowly charge the battery before storage and every 60 days thereafter for 24 hours to prevent lead sulfation of the battery.

To prevent the battery from freezing, make sure it is fully charged. The specific gravity of a fully charged battery is 1.265 to 1.299.
  - D. Clean the battery, terminals, and posts with a wire brush and baking-soda solution.
  - E. Coat the cable terminals and battery posts with Grafo 112X skin-over grease (Toro Part No. 505-47) or petroleum jelly to prevent corrosion.

- F. Either store the battery on the shelf or on the machine in a cool area. Leave the cables disconnected if the battery is stored on the machine.

## **Preparing the Engine**

1. Drain the engine oil from the oil pan and replace the drain plug.
2. Remove and discard the oil filter. Install a new oil filter.
3. Refill the oil pan with approximately 3.8 L (4 US qt) of SAE 15W-40 motor oil.
4. Start the engine and run it at idle speed for approximately 2 minutes.
5. Shut off the engine.
6. Thoroughly drain all fuel from the fuel tank, fuel lines, fuel filter, and water-separator assembly.
7. Flush the fuel tank with fresh, clean diesel fuel.
8. Secure all fuel system fittings.
9. Thoroughly clean and service the air-cleaner assembly.
10. Seal the air-cleaner inlet and the exhaust outlet with weatherproof tape.
11. Check the antifreeze protection and add antifreeze/coolant as needed for the expected minimum temperature in your area.

## **European Privacy Notice**

### **The Information Toro Collects**

Toro Warranty Company (Toro) respects your privacy. In order to process your warranty claim and contact you in the event of a product recall, we ask you to share certain personal information with us, either directly or through your local Toro company or dealer.

The Toro warranty system is hosted on servers located within the United States where privacy law may not provide the same protection as applies in your country.

**BY SHARING YOUR PERSONAL INFORMATION WITH US, YOU ARE CONSENTING TO THE PROCESSING OF YOUR PERSONAL INFORMATION AS DESCRIBED IN THIS PRIVACY NOTICE.**

### **The Way Toro Uses Information**

Toro may use your personal information to process warranty claims, to contact you in the event of a product recall and for any other purpose which we tell you about. Toro may share your information with Toro's affiliates, dealers or other business partners in connection with any of these activities. We will not sell your personal information to any other company. We reserve the right to disclose personal information in order to comply with applicable laws and with requests by the appropriate authorities, to operate our systems properly or for our own protection or that of other users.

### **Retention of your Personal Information**

We will keep your personal information as long as we need it for the purposes for which it was originally collected or for other legitimate purposes (such as regulatory compliance), or as required by applicable law.

### **Toro's Commitment to Security of Your Personal Information**

We take reasonable precautions in order to protect the security of your personal information. We also take steps to maintain the accuracy and current status of personal information.

### **Access and Correction of your Personal Information**

If you would like to review or correct your personal information, please contact us by email at [legal@toro.com](mailto:legal@toro.com).

## **Australian Consumer Law**

Australian customers will find details relating to the Australian Consumer Law either inside the box or at your local Toro Dealer.



# The Toro Warranty

## A Two-Year Limited Warranty

### Conditions and Products Covered

The Toro Company and its affiliate, Toro Warranty Company, pursuant to an agreement between them, jointly warrant your Toro Commercial product ("Product") to be free from defects in materials or workmanship for two years or 1500 operational hours\*, whichever occurs first. This warranty is applicable to all products with the exception of Aerators (refer to separate warranty statements for these products). Where a warrantable condition exists, we will repair the Product at no cost to you including diagnostics, labor, parts, and transportation. This warranty begins on the date the Product is delivered to the original retail purchaser.

\* Product equipped with an hour meter.

### Instructions for Obtaining Warranty Service

You are responsible for notifying the Commercial Products Distributor or Authorized Commercial Products Dealer from whom you purchased the Product as soon as you believe a warrantable condition exists. If you need help locating a Commercial Products Distributor or Authorized Dealer, or if you have questions regarding your warranty rights or responsibilities, you may contact us at:

Toro Commercial Products Service Department  
Toro Warranty Company  
8111 Lyndale Avenue South  
Bloomington, MN 55420-1196  
952-888-8801 or 800-952-2740  
E-mail: commercial.warranty@toro.com

### Owner Responsibilities

As the Product owner, you are responsible for required maintenance and adjustments stated in your *Operator's Manual*. Failure to perform required maintenance and adjustments can be grounds for disallowing a warranty claim.

### Items and Conditions Not Covered

Not all product failures or malfunctions that occur during the warranty period are defects in materials or workmanship. This warranty does not cover the following:

- Product failures which result from the use of non-Toro replacement parts, or from installation and use of add-on, or modified non-Toro branded accessories and products. A separate warranty may be provided by the manufacturer of these items.
- Product failures which result from failure to perform recommended maintenance and/or adjustments. Failure to properly maintain your Toro product per the Recommended Maintenance listed in the *Operator's Manual* can result in claims for warranty being denied.
- Product failures which result from operating the Product in an abusive, negligent, or reckless manner.
- Parts subject to consumption through use unless found to be defective. Examples of parts which are consumed, or used up, during normal Product operation include, but are not limited to, brake pads and linings, clutch linings, blades, reels, rollers and bearings (sealed or greasable), bed knives, spark plugs, castor wheels and bearings, tires, filters, belts, and certain sprayer components such as diaphragms, nozzles, and check valves, etc.
- Failures caused by outside influence. Conditions considered to be outside influence include, but are not limited to, weather, storage practices, contamination, use of unapproved fuels, coolants, lubricants, additives, fertilizers, water, or chemicals, etc.
- Failure or performance issues due to the use of fuels (e.g. gasoline, diesel, or biodiesel) that do not conform to their respective industry standards.

### Countries Other than the United States or Canada

Customers who have purchased Toro products exported from the United States or Canada should contact their Toro Distributor (Dealer) to obtain guarantee policies for your country, province, or state. If for any reason you are dissatisfied with your Distributor's service or have difficulty obtaining guarantee information, contact the Toro importer.

- Normal noise, vibration, wear and tear, and deterioration.
- Normal "wear and tear" includes, but is not limited to, damage to seats due to wear or abrasion, worn painted surfaces, scratched decals or windows, etc.

### Parts

Parts scheduled for replacement as required maintenance are warranted for the period of time up to the scheduled replacement time for that part. Parts replaced under this warranty are covered for the duration of the original product warranty and become the property of Toro. Toro will make the final decision whether to repair any existing part or assembly or replace it. Toro may use remanufactured parts for warranty repairs.

### Deep Cycle and Lithium-Ion Battery Warranty:

Deep cycle and Lithium-Ion batteries have a specified total number of kilowatt-hours they can deliver during their lifetime. Operating, recharging, and maintenance techniques can extend or reduce total battery life. As the batteries in this product are consumed, the amount of useful work between charging intervals will slowly decrease until the battery is completely worn out. Replacement of worn out batteries, due to normal consumption, is the responsibility of the product owner. Battery replacement may be required during the normal product warranty period at owner's expense. Note: (Lithium-Ion battery only): A Lithium-Ion battery has a part only prorated warranty beginning year 3 through year 5 based on the time in service and kilowatt hours used. Refer to the *Operator's Manual* for additional information.

### Maintenance is at Owner's Expense

Engine tune-up, lubrication, cleaning and polishing, replacement of filters, coolant, and completing recommended maintenance are some of the normal services Toro products require that are at the owner's expense.

### General Conditions

Repair by an Authorized Toro Distributor or Dealer is your sole remedy under this warranty.

**Neither The Toro Company nor Toro Warranty Company is liable for indirect, incidental or consequential damages in connection with the use of the Toro Products covered by this warranty, including any cost or expense of providing substitute equipment or service during reasonable periods of malfunction or non-use pending completion of repairs under this warranty. Except for the Emissions warranty referenced below, if applicable, there is no other express warranty. All implied warranties of merchantability and fitness for use are limited to the duration of this express warranty.**

Some states do not allow exclusions of incidental or consequential damages, or limitations on how long an implied warranty lasts, so the above exclusions and limitations may not apply to you. This warranty gives you specific legal rights, and you may also have other rights which vary from state to state.

### Note regarding engine warranty:

The Emissions Control System on your Product may be covered by a separate warranty meeting requirements established by the U.S. Environmental Protection Agency (EPA) and/or the California Air Resources Board (CARB). The hour limitations set forth above do not apply to the Emissions Control System Warranty. Refer to the Engine Emission Control Warranty Statement supplied with your product or contained in the engine manufacturer's documentation for details.



**Count on it.**