



TX 420



Dingo[®] Traction Unit

Model No. 22306—200000001 and Up

Operator's Manual

Contents

	Page
Introduction	2
Safety	3
Safe Operating Practices	3
Toro Safety	4
Slope Chart	6
Safety and Instruction Decals	7
Assembly	8
Activating the Battery	8
Specifications	9
Attachments	9
Stability Data	10
Before Operating	11
Adding Fuel	11
Checking the Oil Level	12
Removing Debris from the Traction Unit	12
Checking the Hydraulic Fluid	12
Operation	13
Traction Unit Overview	13
Controls	14
Starting and Stopping the Engine	16
Stopping the Traction Unit	16
Moving a Non-functioning Traction Unit	16
Using the Cylinder Lock	17
Using Attachments	17
Securing the Traction Unit for Transport	19
Maintenance	20
Service Interval Chart	20
Accessing the Engine and Internal Components	21
Adjusting the Controls	23
Servicing the Air Cleaner	24
Servicing the Engine Oil	25
Servicing the Tracks	26
Servicing the Spark Plugs	28
Greasing the Traction Unit	29
Changing the Fuel Filter	29
Draining the Fuel Tank	30
Servicing the Hydraulic System	30
Servicing the Battery	32
Cleaning the Chassis	33
Storage	34
Troubleshooting	35
The Toro Dingo Product Line Warranty	36

WARNING

The engine exhaust from this product contains chemicals known to the State of California to cause cancer, birth defects, or other reproductive harm.

Introduction

Thank you for purchasing a Toro product.

All of us at Toro want you to be completely satisfied with your new product, so feel free to contact your local Authorized Service Dealer for help with service, genuine replacement parts, or other information you may require.

Whenever you contact your Authorized Service Dealer or the factory, always know the model and serial numbers of your product. These numbers will help the Service Dealer or Service Representative provide exact information about your specific product. The two numbers are stamped into a plate mounted on under the hood near the belt drive.

For your convenience, write the product model and serial numbers in the space below.

Model No.: _____

Serial No. _____

Read this manual carefully to learn how to operate and maintain your product correctly. Reading this manual will help you and others avoid personal injury and damage to the product. Although we design, produce and market safe, state-of-the-art products, you are responsible for using the product properly and safely. You are also responsible for training persons, who you allow to use the product, about safe operation.

The warning system in this manual identifies potential hazards and has special safety messages that help you and others avoid personal injury, even death. **DANGER**, **WARNING** and **CAUTION** are signal words used to identify the level of hazard. However, regardless of the hazard, be extremely careful.

DANGER signals an extreme hazard that will cause serious injury or death if the recommended precautions are not followed.

WARNING signals a hazard that may cause serious injury or death if the recommended precautions are not followed.

CAUTION signals a hazard that may cause minor or moderate injury if the recommended precautions are not followed.

Two other words are also used to highlight information. “Important” calls attention to special mechanical information and “Note” emphasizes general information worthy of special attention.



The left and right side of the machine is determined by standing in the normal operator’s position.

Safety

Improper use or maintenance by the operator or owner can result in injury. To reduce the potential for injury, comply with these safety instructions and always pay attention to the safety alert  symbol, which means CAUTION, WARNING, or DANGER—“personal safety instruction.” Failure to comply with the instruction may result in personal injury or death.

Safe Operating Practices

This product is capable of amputating hands and feet. Always follow all safety instructions to avoid serious injury or death.

	WARNING	
POTENTIAL HAZARD		
<ul style="list-style-type: none">• Engine exhaust contains carbon monoxide, which is an odorless, deadly poison.		
WHAT CAN HAPPEN		
<ul style="list-style-type: none">• Carbon monoxide can kill you and is also known to the State of California to cause birth defects.		
HOW TO AVOID THE HAZARD		
<ul style="list-style-type: none">• Do not run engine indoors or in an enclosed area.		

Because in some areas there are local, state, or federal regulations requiring that a spark-arrester be used on engines, a spark-arrester is available as an option for the traction unit. If a spark-arrester is required, contact your Toro dealer. Genuine Toro approved spark-arresters are approved by the USDA Forestry Service. It is a violation of the State of California PRC Section 4442 to use or operate the engine on any forest-covered, brush-covered, or grass-covered land, unless the engine is equipped with a spark-arrester, maintained in working order, or the engine is constricted, equipped, and maintained for the prevention of fire.

The following instructions are adapted from ANSI standard B71.4—1999.

Training

- Read the Operator’s Manual and other training material. If the operator(s) or mechanic(s) can not read English, it is the owner’s responsibility to explain this material to them.
- Become familiar with the safe operation of the equipment, operator controls, and safety signs.
- All operators and mechanics should be trained. The owner is responsible for training the users.
- Never let children or untrained people operate or service the equipment. Local regulations may restrict the age of the operator.
- The owner/user can prevent and is responsible for accidents or injuries occurring to himself or herself, other people or property.

Preparation

- Evaluate the terrain to determine what accessories and attachments are needed to properly and safely perform the job. Only use accessories and attachments approved by the manufacturer.
- Wear appropriate clothing including hard hat, safety glasses, long pants, safety shoes, and ear protection. Long hair, loose clothing or jewelry may get tangled in moving parts.
- Inspect the area where the equipment is to be used and remove all objects such as rocks, toys, and wire which can be thrown by the machine.
- Use extra care when handling gasoline and other fuels. They are flammable and vapors are explosive.
 - Use only an approved container
 - Never remove the gas cap or add fuel with the engine running. Allow the engine to cool before refueling. Do not smoke.
 - Never refuel or drain the machine indoors.
- Check that the operator’s presence controls, safety switches, and shields are attached and functioning properly. Do not operate unless they are functioning properly.

Operation

- Never run an engine in an enclosed area.
- Only operate in good light, keeping away from holes and hidden hazards.
- Be sure all drives are in neutral and parking brake is engaged before starting the engine. Only start the engine from the operator’s position.

- Slow down and use extra care on hillsides. Be sure to travel in the recommended direction on hillsides. Turf conditions can affect the machine's stability.
- Slow down and use caution when making turns and when changing directions on slopes.
- Never operate with the guards not securely in place. Be sure all interlocks are attached, adjusted properly, and functioning properly.
- Do not change the engine governor setting or overspeed the engine.
- Stop on level ground, lower implements, disengage the auxiliary hydraulics, engage parking brake (if provided), shut off the engine before leaving the operator's position for any reason.
- Keep hands and feet away from moving attachments.
- Look behind and down before backing up to be sure of a clear path.
- Never carry passengers and keep pets and bystanders away.
- Slow down and use caution when making turns and crossing roads and sidewalks.
- Do not operate the machine under the influence of alcohol or drugs
- Use care when loading or unloading the machine into a trailer or truck
- Use care when approaching blind corners, shrubs, trees, or other objects that may obscure vision.

Maintenance and Storage

- Disengage the auxiliary hydraulics, lower the attachment, set the parking brake, stop the engine, and remove the key. Wait for all movement to stop before adjusting, cleaning, or repairing.
- Clean debris from attachments, drives, mufflers, and engine to help prevent fires. Clean up oil or fuel spillage.
- Let the engine cool before storing and do not store near flame.
- Do not store fuel near flames or drain indoors.
- Park the machine on level ground. Never allow untrained personnel to service the machine.
- Use jack stands to support components when required.
- Carefully release pressure from components with stored energy.
- Disconnect the battery or remove the spark plug wires before making any repairs. Disconnect the negative terminal first and the positive last. Reconnect positive first and negative last.

- Keep hands and feet away from moving parts. If possible, do not make adjustments with the engine running.
- Charge batteries in an open well ventilated area, away from spark and flames. Unplug the charger before connecting or disconnecting it from the battery. Wear protective clothing and use insulated tools.
- Keep all parts in good working condition and all hardware tightened. Replace all worn or damaged decals.

Toro Safety

The following list contains safety information specific to Toro products or other safety information that you must know that is not included in the ANSI standards.

General Operation

- Read all attachment manuals.
- Ensure that the area is clear of other people before operating the traction unit. Stop the traction unit if anyone enters the area.
- Never leave a running traction unit unattended. Always lower the loader arms, stop the engine, set the parking brake, and remove the key before leaving.
- Do not exceed the rated operating capacity, as the traction unit may become unstable which may result in loss of control.
- Do not carry a load with the arms raised. Always carry loads close to the ground.
- Do not over-load the attachment and always keep the load level when raising the loader arms. Logs, boards, and other items could roll down the loader arms, injuring you.
- Never jerk the controls; use a steady motion.
- Watch for traffic when operating near or crossing roadways.
- Do not touch parts which may be hot from operation. Allow them to cool before attempting to maintain, adjust, or service.
- Check for overhead clearances (i.e. branches, doorways, electrical wires) before driving under any objects and do not contact them.
- Before digging, have the area marked for underground utilities, and do not dig in marked areas.
- Locate the pinch point areas marked on the traction unit and attachments and keep hands and feet away from these areas.

Slope Operation

Slopes are a major factor related to loss-of-control and tip-over accidents, which can result in severe injury or death. All slopes require extra caution.

- Do not operate the traction unit on hillsides or slopes exceeding the angles recommended in the Stability Data section, page 10, and those in the attachment operator's manual. See also the slope chart on page 6.
- **Operate up and down slopes with the heavy end of the traction unit uphill.** Weight distribution changes. An empty bucket will make the rear of the traction unit the heavy end, and a full bucket will make the front of the traction unit the heavy end. Most other attachments will make the front of traction unit the heavy end.
- Raising the loader arms on a slope will affect the stability of the machine. Whenever possible, keep the loader arms in the lowered position when on slopes.
- Removing an attachment on a slope will make the rear of the traction unit heavy. Refer to the Stability Data section, page 10, to determine whether the attachment can be safely removed on the slope.
- Remove obstacles such as rocks, tree limbs, etc. from the work area. Watch for holes, ruts, or bumps, as uneven terrain could overturn the traction unit. Tall grass can hide obstacles.
- Use only Toro-approved attachments. Attachments can change the stability and the operating characteristics of the traction unit. Warranty may be voided if used with unapproved attachments.
- Keep all movements on slopes slow and gradual. Do not make sudden changes in speed or direction.
- Avoid starting or stopping on a slope. If the traction unit loses traction, proceed slowly, straight down the slope.
- Avoid turning on slopes. If you must turn, turn slowly and keep the heavy end of the traction unit uphill.
- Do not operate near drop-offs, ditches, or embankments. The traction unit could suddenly turn over if a track goes over the edge of a cliff or ditch, or if an edge caves in.
- Do not operate on wet grass. Reduced traction could cause sliding.
- Do not park the traction unit on a hillside or slope without lowering the attachment to the ground and setting the parking brake.

Service

- If any maintenance or repair requires the loader arms to be in the raised position, secure the arms in the raised position with the hydraulic cylinder lock.
- Keep nuts and bolts tight. Keep equipment in good condition.
- Never tamper with safety devices.
- Keep the traction unit free of grass, leaves, or other debris build-up. Clean up oil or fuel spillage. Allow the traction unit to cool before storing.
- Use extra care when handling gasoline and other fuels. They are flammable and vapors are explosive.
 - Use only an approved container.
 - Never remove the gas cap or add fuel when the engine is running. Allow the engine to cool before refueling. Do not smoke.
 - Never refuel the traction unit indoors.
 - Never store the traction unit or fuel container inside where there is an open flame, such as near a water heater or furnace.
 - Never fill a container while it is inside a vehicle, trunk, pick-up bed, or any surface other than the ground.
 - Keep container nozzle in contact with the tank during filling.
- Stop and inspect the equipment if you strike an object. Make any necessary repairs before restarting.
- Use only genuine Toro replacement parts to ensure that original standards are maintained.
- Battery acid is poisonous and can cause burns. Avoid contact with skin, eyes, and clothing. Protect your face, eyes, and clothing when working with a battery.
- Battery gases can explode. Keep cigarettes, sparks and flames away from the battery.
- Keep your body and hands away from pin hole leaks or nozzles that eject high pressure hydraulic fluid. Use cardboard or paper to find hydraulic leaks; never use your hands. Hydraulic fluid escaping under pressure can penetrate skin and cause injury requiring surgery within a few hours by a qualified surgeon or gangrene may result.

Slope Chart

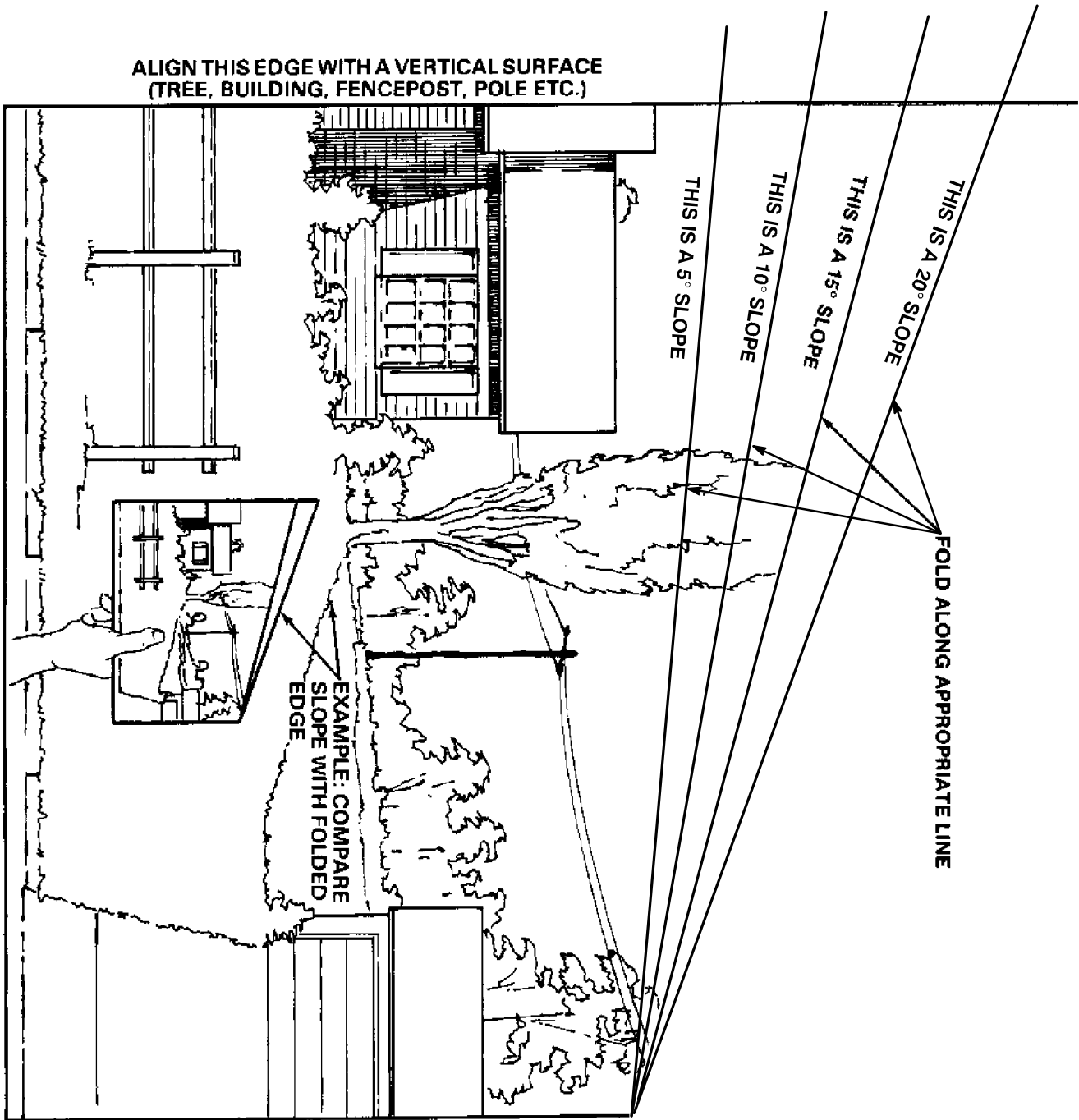

M - 4402

Safety and Instruction Decals



Safety decals and instructions are easily visible to the operator and are located near any area of potential danger. Replace any decal that is damaged or lost.



On Loader Cross Bar
(Part No. 100-6132)

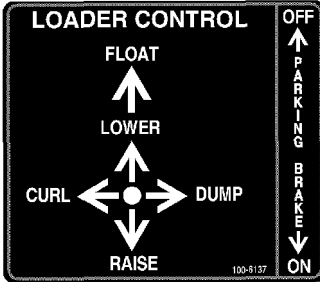

On Right Control Panel
(Part No. 100-6137)

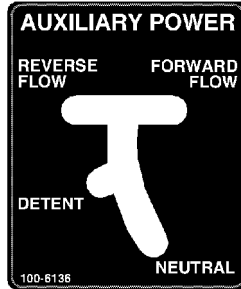

On Left Control Panel
(Part No. 100-6136)

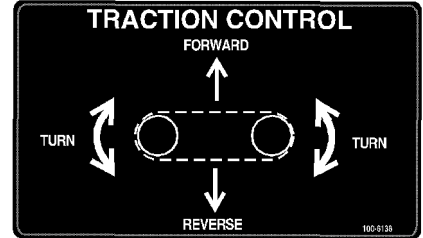

On Traction Control
(Part No. 100-6138)

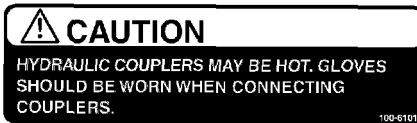

On Loader Arms by the Hydraulic Couplers
(Part No. 100-6101)



Six on Both Sides of Frame and Loader, and on top of Loader Arms
(Part No. 100-6141)



On Pump Plate
(Part No. 80-8040)



On Cylinder Lock
(Part No. 100-6135)

On Control Panel
(Part No. 100-6139)

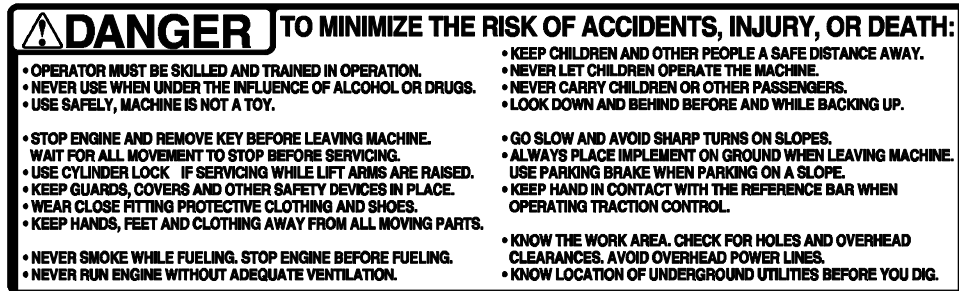
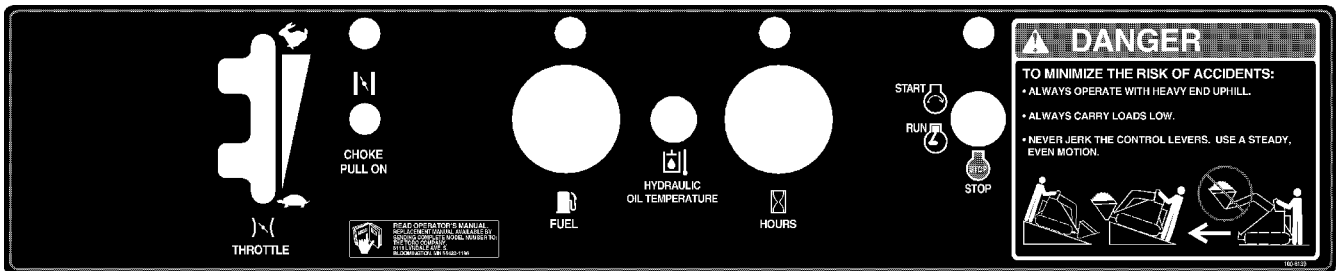

On Center Control Panel
(Part No. 100-6140)

Assembly

Activating the Battery

WARNING

Battery posts, terminals, and related accessories contain lead and lead compounds, chemicals known to the State of California to cause cancer and reproductive harm. *Wash hands after handling.*

The traction unit is shipped with a dry battery. Purchase bulk electrolyte with 1.260 specific gravity from a local battery supply outlet.

1. Open the rear access cover; refer to Opening the Rear Access Cover, page 21.
2. Remove the bolts and clamp securing the battery (Fig. 1).

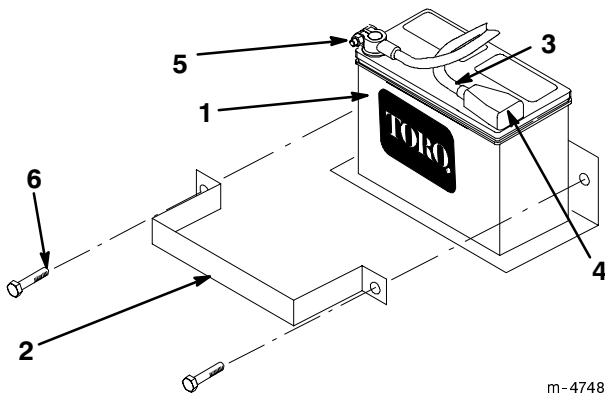

Figure 1

- | | |
|-------------------|-------------------|
| 1. Battery | 4. Rubber cover |
| 2. Clamp | 5. Negative cable |
| 3. Positive cable | 6. Bolts |

3. Tilt the top of the battery rearward and slide it out of the traction unit.

IMPORTANT: Do not allow the battery posts to touch the frame or hydraulic lines or it may cause sparks.

DANGER

POTENTIAL HAZARD

- Battery electrolyte contains sulfuric acid which is a deadly poison and it causes severe burns.

WHAT CAN HAPPEN

- If you drink electrolyte you could die or if it gets onto your skin you will be burned.

HOW TO AVOID THE HAZARD

- Do not drink electrolyte and avoid contact with skin, eyes or clothing. Wear safety glasses to shield your eyes and rubber gloves to protect your hands.
- Fill the battery where clean water is always available for flushing the skin.
- Follow all instructions and comply with all safety messages on the electrolyte container.

4. Remove filler caps from the battery. Slowly pour electrolyte into each cell until the electrolyte level is up to the lower part of the tube (Fig. 2).

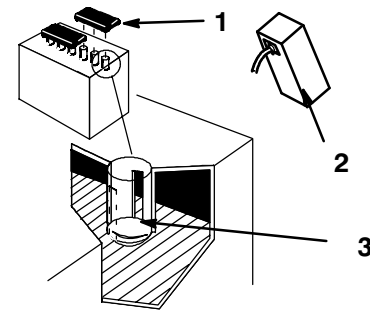
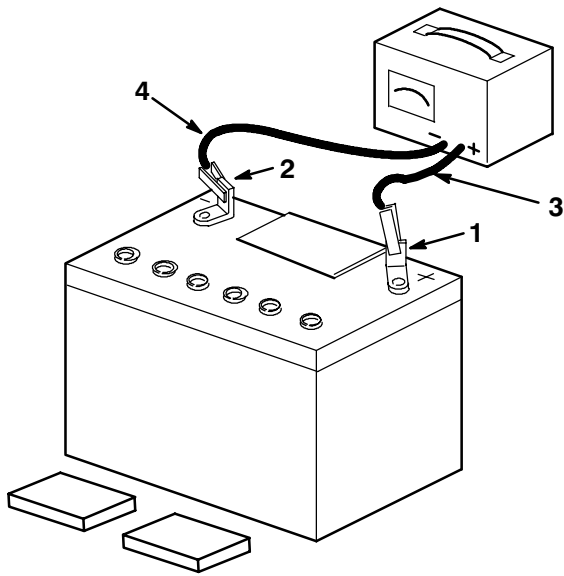

Figure 2

- | | |
|----------------|---------------------------|
| 1. Filler caps | 3. Lower part of the tube |
| 2. Electrolyte | |

5. Leave the covers off and connect a 3 to 4 amp battery charger to the battery posts (Fig. 3). Charge the battery at a rate of 4 amperes or less for 4 hours (12 volts).



1254

Figure 3

- | | |
|------------------|---------------------------|
| 1. Positive post | 3. Charger red (+) wire |
| 2. Negative post | 4. Charger black (-) wire |

! **WARNING** !

POTENTIAL HAZARD

- Charging the battery produces gasses.

WHAT CAN HAPPEN

- Battery gasses can explode.

HOW TO AVOID THE HAZARD

- Keep cigarettes, sparks, and flames away from the battery.

6. When the battery is fully charged, disconnect the charger from the electrical outlet and from the negative and positive battery posts (Fig. 3).
7. Slowly pour electrolyte into each cell until the level is once again up to the upper line on the battery case (Fig. 2) and install covers.
8. Tilt the top of the battery rearward and slide it into the traction unit.

IMPORTANT: Do not allow the battery posts to touch the frame or hydraulic lines or it may cause sparks.

9. Secure the battery in chassis with the clamp and bolts removed previously (Fig. 1).
10. Using the bolt and nut supplied with the battery, connect the positive (red) cable to the positive (+) battery post (Fig. 1). Slide the rubber cover over the battery post.
11. Using the bolt and nut supplied with the battery, connect the negative (black) cable to the negative (-) battery post (Fig. 1).

Note: Ensure that the battery cables do not contact any sharp edges or each other.

12. Close the rear access cover.

Specifications

Width	34 inches (86 cm)
Length	71 inches (180 cm)
Height	43 inches (109 cm)
Weight	1830 lbs (830 Kg)
Operating capacity	500 lbs (227 Kg)
Tipping capacity	1480 lbs (671 Kg)
Wheelbase	31.2 inches (79 cm)
Dump height (with narrow bucket)	47 inches (119 cm)
Reach—fully raised (with narrow bucket)	22 inches (55 cm)
Height to hinge pin (narrow bucket in the highest position)	66 inches (168 cm)

Specifications and design are subject to change without notice.



Attachments

Many attachments are available for use with the traction unit. These attachments allow you to perform many different functions with the traction unit such as hauling materials, digging holes, grading, and more. Contact your Toro dealer for a list of all approved attachments and accessories.

IMPORTANT: Use only Toro-approved attachments.

Stability Data

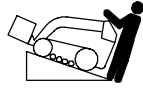
The following table lists the maximum slope recommended for the traction unit in the positions listed in the table. Slopes over the listed degree may cause the traction unit to become unstable. The data in the table assumes that the loader arms are fully lowered; raised arms may affect the stability.

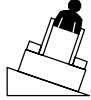
Configuration	Maximum Recommended Slope when Operating with:		
	Front Uphill 	Rear Uphill 	Side Uphill 
Traction unit without attachment	11°	21°	19°
Traction unit with an attachment rated with one of the following stability ratings for each slope position:*			
A	25°	25°	20°
B	20°	20°	18°
C	17°	17°	14°
D	10°	12°	9°
E	5°	5°	5°

* In each attachment manual is a set of three stability ratings, one for each hill position. To determine the maximum slope you can traverse with the attachment installed, find the degree of slope that corresponds to the stabilities ratings of the attachment.

Example: If the attachment installed on the traction unit has a Front Uphill rating of B, a Rear Uphill rating of D, and a Side Uphill rating of C, then you could drive forward up a 20° slope, rearward up a 12° slope, or sideways on a 14° slope, as listed in the above table.



Before Operating

Before operating, check the fuel and oil level, and remove debris from the traction unit. Also, ensure that the area is clear of people and debris. You should also know and have marked the locations of all utility lines.

Adding Fuel

Use unleaded gasoline (85 pump octane minimum). Leaded, regular gasoline may be used if unleaded is not available.

IMPORTANT: Do not use methanol, gasoline containing methanol, or gasohol containing more than 10% ethanol because the fuel system could be damaged. Do not mix oil with gasoline.

 **DANGER** 

POTENTIAL HAZARD



- When fueling, under certain circumstances, a static charge can develop, igniting the gasoline.

WHAT CAN HAPPEN

- A fire or explosion from gasoline can burn you, others, and cause property damage.

HOW TO AVOID THE HAZARD

- Always place gasoline containers on the ground away from your vehicle before filling.
- Do not fill gasoline containers inside a vehicle or on a truck or trailer bed because interior carpets or plastic truck bed liners may insulate the container and slow the loss of any static charge.
- When practical, remove gas-powered equipment from the truck or trailer and refuel the equipment with its wheels on the ground.
- If this is not possible, then refuel such equipment on a truck or trailer from a portable container, rather than from a gasoline dispenser nozzle.
- If a gasoline dispenser nozzle must be used, keep the nozzle in contact with the rim of the fuel tank or container opening at all times until fueling is complete.

 **DANGER** 

POTENTIAL HAZARD

- In certain conditions gasoline is extremely flammable and highly explosive.

WHAT CAN HAPPEN

- A fire or explosion from gasoline can burn you, others, and cause property damage.

HOW TO AVOID THE HAZARD

- Fill the fuel tank outdoors, in an open area, when the engine is cold. Wipe up any gasoline that spills.
- Do not fill the fuel tank completely full. Add gasoline to the fuel tank until the level is 1/4" to 1/2" (6 mm to 13 mm) below the bottom of the filler neck. This empty space in the tank allows gasoline to expand.
- Never smoke when handling gasoline, and stay away from an open flame or where gasoline fumes may be ignited by a spark.
- Store gasoline in an approved container and keep it out of the reach of children. Never buy more than a 30-day supply of gasoline.

Using Stabilizer/Conditioner

Use a fuel stabilizer/conditioner in the traction unit to provide the following benefits:

- Keeps gasoline fresh during storage of 90 days or less. For longer storage it is recommended that the fuel tank be drained.
- Cleans the engine while it runs
- Eliminates gum-like varnish buildup in the fuel system, which causes hard starting

IMPORTANT: Do not use fuel additives containing methanol or ethanol.

Add the correct amount of gas stabilizer/conditioner to the gas.

Note: A fuel stabilizer/conditioner is most effective when mixed with fresh gasoline. To minimize the chance of varnish deposits in the fuel system, use fuel stabilizer at all times.

Filling the Fuel Tank

1. Park the traction unit on a level surface, lower the loader arms, and stop the engine.
2. Remove the key and allow the engine to cool.
3. Clean around the fuel tank cap and remove it.

4. Add unleaded gasoline to the fuel tank, until the level is just below the bottom of the filler neck.

IMPORTANT: This space in the tank allows gasoline to expand. Do not fill the fuel tank completely full.

5. Install the fuel tank cap securely.
6. Wipe up any gasoline that may have spilled.

Checking the Oil Level

1. Park the traction unit on a level surface, lower the loader arms, and stop the engine.
2. Remove the key and allow the engine to cool.
3. Open the hood; refer to Opening the Hood, page 21.
4. Loosen the T-handle securing the oil cooler (Fig. 4).
5. Swing the cooler forward (Fig. 4).

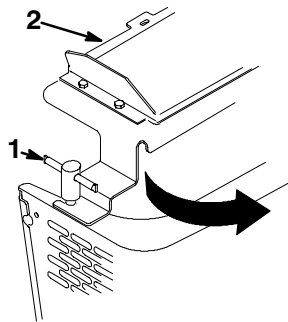

m-4926

Figure 4

1. T-handle
2. Oil cooler

6. Clean around the oil dipstick (Fig. 5).
7. Pull out the dipstick and wipe the metal end clean (Fig. 5).
8. Slide the dipstick fully into the dipstick tube (Fig. 5).

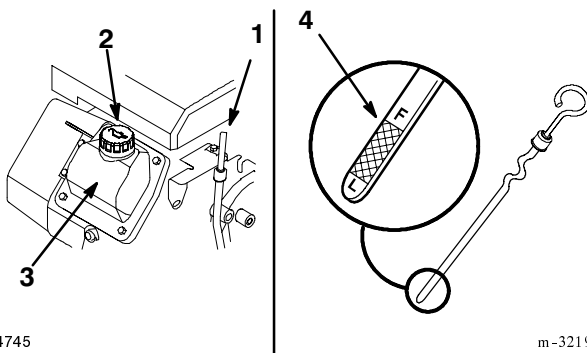

m-4745

m-3219

Figure 5

1. Oil dipstick
2. Filler cap
3. Valve cover
4. Metal end

9. Pull the dipstick out and look at the metal end.

10. If the oil level is low, clean around the oil filler cap and remove the cap (Fig. 5).

11. Slowly pour only enough oil into the valve cover to raise the level to the F (full) mark.

IMPORTANT: Do not overfill the crankcase with oil because the engine may be damaged.

12. Replace the filler cap and dipstick.
13. Swing the oil cooler back into position and secure it with the T-handle.
14. Close the hood.

Removing Debris from the Traction Unit

IMPORTANT: Operating the engine with blocked screens, dirty or plugged cooling fins, and/or cooling shrouds removed, will result in engine damage from overheating.

1. Park the traction unit on a level surface, lower the loader arms, and stop the engine.
2. Remove the key and allow the engine to cool.
3. Open the hood; refer to Opening the Hood, page 21.
4. Clean any debris from the front and side screens.
5. Wipe away debris from the air cleaner.
6. Clean any debris build-up on the engine and in the oil cooler fins with a brush or blower.

IMPORTANT: It is preferable to blow dirt out, rather than washing it out. If water is used, keep it away from electrical items and hydraulic valves. Do not use a high-pressure washer. High-pressure washing can damage the electrical system and hydraulic valves or deplete grease.

7. Clean debris from the cooler fan grill on the hood.
8. Close the hood.

Checking the Hydraulic Fluid

Check the hydraulic fluid level before the engine is first started and after every 25 operating hours.

Hydraulic Tank Capacity: 6.5 gal. (24.6 l)

Use only Group 1 ISO type 46/68 anti-wear hydraulic fluids, recommended for ambient temperatures consistently below 100° F, such as Toro Hy-Pro, Mobil Fluid 424, or other equivalent fluid.

IMPORTANT: Use only the Group 1 ISO type 46/68 anti-wear hydraulic fluids. Other fluids could cause system damage.

1. Remove the attachment, if one is installed; refer to Removing an Attachment, page 19.
2. Park the traction unit on a level surface, lower the loader arms, and fully retract the tilt cylinder.
3. Stop the engine, remove the key, and allow the engine to cool.
4. Open the hood; refer to Opening the Hood, page 21.
5. Clean the area around the filler neck of the hydraulic tank (Fig. 6).
6. Remove the cap from the filler neck and check the fluid level on the dipstick (Fig. 6).

The fluid level should be between the marks on the dipstick.

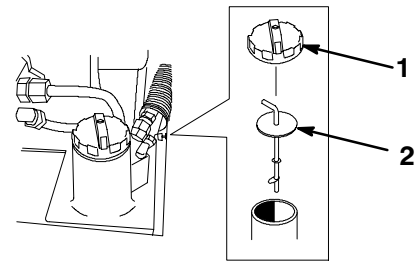

m-4650

Figure 6

1. Filler neck cap
2. Dipstick

7. If the level is low, add enough fluid to raise it to the proper level.
8. Install the cap on the filler neck.
9. Close the hood.

Operation

Traction Unit Overview

Figure 7 contains a front and back view of the traction unit. Familiarize yourself with all of the traction unit components listed in Figure 7.

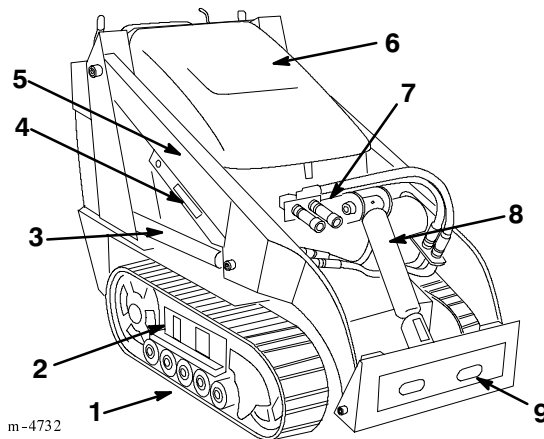

m-4732

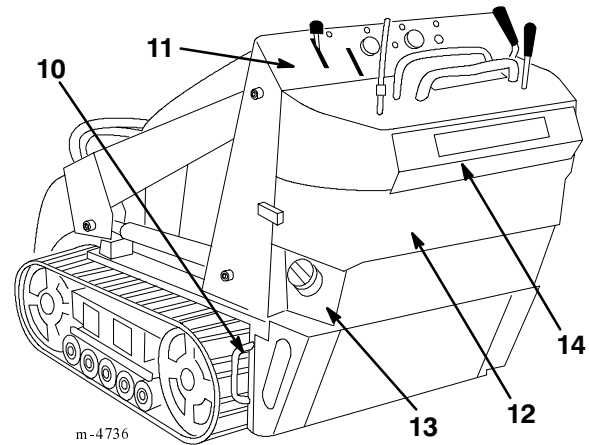

m-4736

Figure 7

- | | | | |
|-----------------------------|---------------------------------|-------------------|--------------------------|
| 1. Track | 5. Loader arms | 9. Mount plate | 12. Rear access cover |
| 2. Track adjustment chamber | 6. Hood | 10. Tie-down loop | 13. Fuel tank |
| 3. Lift cylinder | 7. Auxiliary hydraulic couplers | 11. Control panel | 14. Reverse safety plate |
| 4. Cylinder lock | 8. Tilt cylinder | | |

Controls

Become familiar with all the controls (Fig. 8) before you start the engine and operate the traction unit.

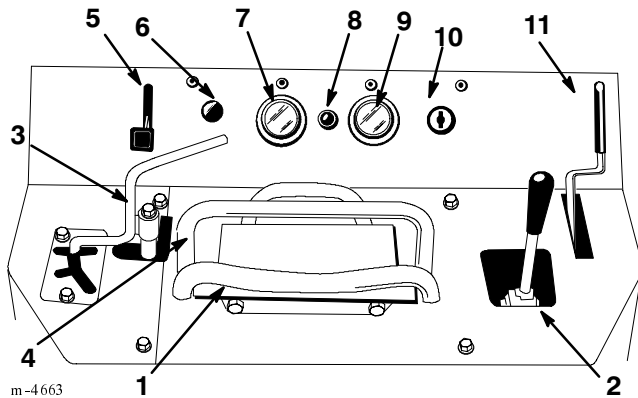

Figure 8

- | | |
|-------------------------------------|------------------------------------|
| 1. Traction control | 7. Fuel gauge |
| 2. Loader arm/attachment tilt lever | 8. Hydraulic oil temperature light |
| 3. Auxiliary hydraulics lever | 9. Hour meter |
| 4. Reference bar | 10. Key switch |
| 5. Throttle lever | 11. Parking brake lever |
| 6. Choke knob | |

Key Switch

The key switch, used to start and stop the engine, has three positions: off, run, and start.

To start the engine, rotate the key to the start position. Release the key when engine starts and it will move automatically to the run position.

To stop the engine, rotate the key to the off position.

Throttle Lever

Move the control forward to increase the engine speed and rearward to decrease speed.

Choke Knob

Before starting a cold engine, pull the choke knob out. After the engine starts, regulate the choke to keep the engine running smoothly. As soon as possible, push the choke knob in as far as possible. A warm engine requires little or no choking.

Reference Bar

When driving the traction unit, use the reference bar as a handle and a leverage point for controlling the traction control and the auxiliary hydraulics lever. To ensure smooth, controlled operation, do not take both hands off of the reference bar while operating the traction unit.

Traction Control

To move forward, move the traction control forward. To move rearward, move the traction control rearward (Fig. 9).

To turn, rotate the traction control in the desired direction (Fig. 9).

The farther you move the traction control in any direction, the faster the traction unit will move in that direction.

To stop, release the traction control.

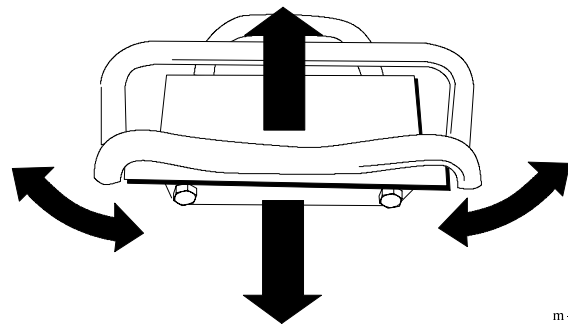

Figure 9

Loader Arm/Attachment Tilt Lever

To tilt the attachment forward, slowly move the lever to the right (Fig. 10).

To tilt the attachment rearward, slowly move the lever to the left (Fig. 10).

To lower the loader arms, slowly move the lever forward (Fig. 10).

To raise the loader arms, slowly move the lever rearward (Fig. 10).

You can also push the lever fully forward into a detent position (Fig. 10) to release the loader arms so that the attachment rests on the ground. This allows attachments such as the leveler and the hydraulic blade to follow the contours of the ground (i.e., float) when grading.

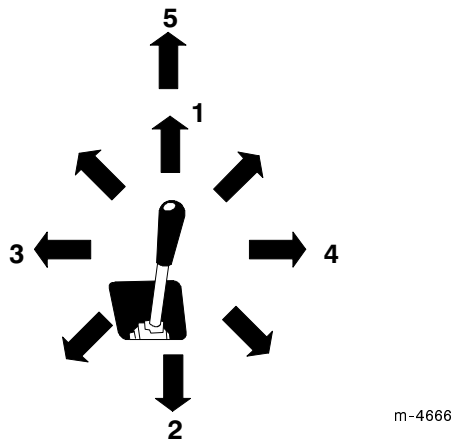

Figure 10

- | | |
|---------------------------------|--------------------------------|
| 1. Lower the loader arms | 4. Tilt the attachment forward |
| 2. Raise the loader arms | 5. Detent (Float) position |
| 3. Tilt the attachment rearward | |

By moving the lever to an intermediate position (such as, forward and left), you can move the loader arms and tilt the attachment at the same time.

Auxiliary Hydraulics Lever

To operate a hydraulic attachment in the forward direction, rotate the auxiliary hydraulics lever rearward and pull it down to the reference bar (Fig. 11, number 2).

To operate a hydraulic attachment in reverse direction, rotate the hydraulics lever rearward, then move it left into the upper slot (Fig. 11, number 3).

To operate the auxiliary hydraulics in the reverse direction using a detent position, rotate the lever rearward, then move it left into the middle slot (Fig. 11, Number 4). Only use the detent position for attachments that require it for operation, such as the Cement Bowl. To determine if an attachment requires the detent position, refer to the attachment operator's manual.

If you release the lever while in either the forward position or upper reverse position, the lever will automatically return to the neutral position (Fig. 11, Number 1). If it is in the detent position, it will remain there until you pull it out of the slot.

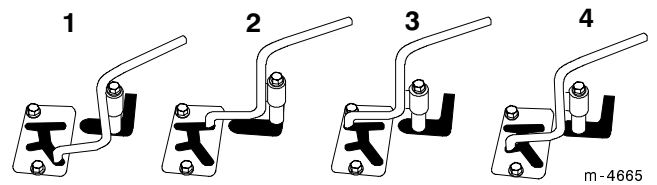

Figure 11

- | | |
|----------------------------|--|
| 1. Neutral | 4. Reverse flow hydraulics—detent position |
| 2. Forward flow hydraulics | |
| 3. Reverse flow hydraulics | |

Parking Brake Lever

To set the parking brake, pull the brake lever rearward and then push it to the left, hooking it into the notch (Fig. 12).

Note: The traction unit may roll slightly before the brakes engage in the drive sprocket.

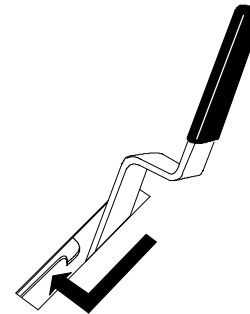

Figure 12

To release the brake, pull the lever rearward and right, out of the notch, and then push it forward.

Fuel Gauge

This gauge measures the amount of fuel in the fuel tank.

Hydraulic Oil Temperature Light

If the hydraulic oil gets too hot, this light illuminates and an audible alarm sounds. If this happens, stop the engine and allow the traction unit to cool.

Hour Meter

This meter displays the number of hours that the traction unit has run since it was built.

Starting and Stopping the Engine

Starting the Engine

1. Ensure that the auxiliary hydraulics lever is in neutral.
2. Move the throttle lever midway between slow (turtle) and fast (rabbit) positions.
3. Pull out the choke lever if you are starting a cold engine.

Note: A warm or hot engine may not require choking.

4. Turn the ignition key to the start position. When the engine starts, release the key.

IMPORTANT: Do not engage the starter for more than 10 seconds at a time. If the engine fails to start, allow a 30 second cool-down period between attempts. Failure to follow these instructions can burn out the starter motor.

5. After the engine starts, gradually push the choke inward. If the engine stalls or hesitates, pull the choke out again until the engine warms up.
6. Move the throttle lever to desired setting.

IMPORTANT: If the engine is run at high speeds when the hydraulic system is cold (i.e., when the ambient air temperature is near freezing or lower), hydraulic system damage could occur. When starting the engine in cold conditions, allow the engine to run in the middle throttle position for 2 to 5 minutes before moving the throttle to fast (rabbit).

Note: If outdoor temperature is below freezing, store the traction unit in a garage to keep it warmer and aid in starting.

Stopping the Engine

1. Move the throttle lever to the slow (turtle) position.
2. Lower the loader arms to the ground.
3. Turn the ignition key off.

Note: If the engine has been working hard or is hot, let it idle for a minute before turning the ignition key off. This helps cool the engine before it is stopped. In an emergency, the engine may be stopped immediately.

Stopping the Traction Unit

To stop the traction unit, release the traction control, move the throttle lever to slow (turtle), lower loader arms to the ground, and stop the engine. Set the parking brake and remove the key.

! **CAUTION** !

POTENTIAL HAZARD

- Someone could move or attempt to operate the traction unit while it is unattended.

WHAT CAN HAPPEN

- Children or bystanders may be injured if they use the traction unit.

HOW TO AVOID THE HAZARD

- Always remove the ignition key when leaving the traction unit, even if just for a few seconds.

Moving a Non-functioning Traction Unit

IMPORTANT: Do not tow or pull the traction unit without first opening the tow valves, or the hydraulic system will be damaged

1. Stop the engine.
2. Open the rear access cover; refer to Opening the Rear Access Cover, page 21.
3. Using a wrench, turn the tow valves on the hydraulic pumps twice counter-clockwise (Fig. 13).

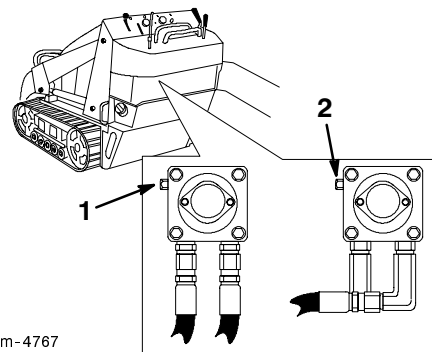

Figure 13

1. Left tow valve (right track)
2. Right tow valve (left track)

4. Tow the traction unit as required.

- When the traction unit has been repaired, close the tow valves before operating it.

Using the Cylinder Lock

! **WARNING** !

POTENTIAL HAZARD

- The loader arms may lower when in the raised position.

WHAT CAN HAPPEN

- Anyone under the loader arms may be injured or crushed.

HOW TO AVOID THE HAZARD

- Always install the cylinder lock when doing maintenance that requires raised loader arms.

Installing the Cylinder Lock

- Start the engine.
- Remove the attachment.
- Raise the loader arms to the fully raised position.
- Stop the engine.
- Remove the hairpin cotter and clevis pin securing the cylinder lock to the loader arm (Fig. 14)
- Lower the cylinder lock over the cylinder rod and secure it with the clevis pin and hairpin cotter (Fig. 14).

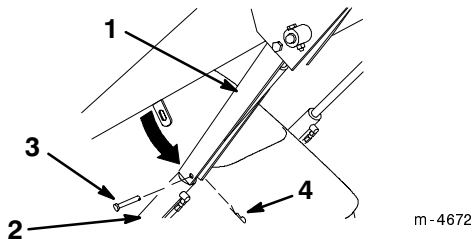

Figure 14

- | | |
|------------------|-------------------|
| 1. Cylinder lock | 3. Clevis pin |
| 2. Lift cylinder | 4. Hairpin cotter |

- Slowly lower the loader arms until cylinder lock contacts the cylinder body and rod end.

Removing/Storing the Cylinder Lock

IMPORTANT: Ensure that the cylinder lock is removed from the rod and fully secured in the storage position before operating the traction unit.

- Start the engine.
- Raise the loader arms to the fully raised position.
- Stop the engine.
- Remove the clevis pin and cotter pin securing the cylinder lock.
- Rotate the cylinder lock up to the loader arm and secure it with the clevis pin and hairpin cotter (Fig. 14).
- Lower the loader arms.

Using Attachments

IMPORTANT: If you are using an attachment with a serial number of 200999999 or earlier, the manual for the attachment may contain information specific to the use of the attachment with other Dingo models, such as settings for the flow divider control and speed selector lever and the use of a counterweight on the traction unit. These systems are built into the Dingo TX, and you should ignore any references to them.

Connecting an Attachment

IMPORTANT: Use only Toro-approved attachments. Attachments can change the stability and the operating characteristics of the traction unit. The warranty of the traction unit may be voided if used with unapproved attachments.

IMPORTANT: Before installing the attachment, ensure that the mount plates are free of any dirt or debris and that the pins rotate freely. If the pins do not rotate freely, grease them; refer to Greasing the Traction Unit, page 29.

- Position the attachment on a level surface with enough space behind it to accommodate the traction unit.
- Start the engine.
- Tilt the attachment mount plate forward.
- Position mount plate into the upper lip of the attachment receiver plate (Fig. 15).

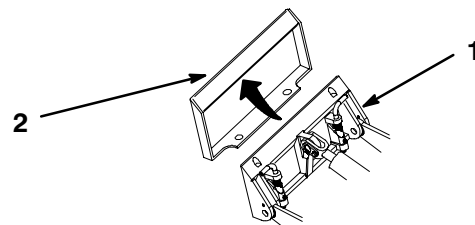

Figure 15

- | | |
|----------------|-------------------|
| 1. Mount plate | 2. Receiver plate |
|----------------|-------------------|

5. Raise the loader arms while tilting back the mount plate at the same time.

IMPORTANT: The attachment should be raised enough to clear the ground, and the mount plate should be tilted all the way back.

6. Stop the engine.
7. Engage the quick attach pins, ensuring that they are fully seated in the mount plate (Fig. 16).

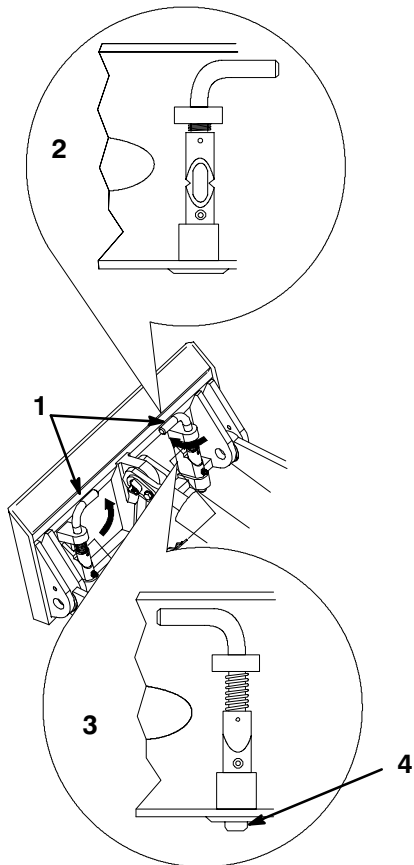

m-4056

Figure 16

- | | |
|--|--|
| 1. Quick attach pins (shown in engaged position) | 4. When engaged, the pin must protrude through the bottom of the attachment mount plate. |
| 2. Disengaged position | |
| 3. Engaged position | |



WARNING



POTENTIAL HAZARD

- If the quick attach pins are not fully seated through the attachment mount plate, the attachment could fall off of the traction unit.

WHAT CAN HAPPEN

- Falling attachments can crush you or bystanders.

HOW TO AVOID THE HAZARD



- Always ensure that your quick attach pins are fully seated in the attachment mount plate.

Connecting the Hydraulic Hoses

If the attachment requires hydraulics for operation, connect the hydraulic hoses as follows:

1. Stop the engine.
2. Move the auxiliary hydraulics lever forward, backward, and back to neutral to relieve pressure at the hydraulic couplers.
3. Move the auxiliary hydraulics lever into the detent position.
4. Remove the protective covers from the hydraulic couplers on the traction unit.
5. Ensure that all foreign matter is cleaned from the hydraulic connectors.
6. Push the attachment male connector into the female connector on the traction unit.

Note: When you connect the attachment male connector first, you will relieve any pressure build up in the attachment.

 **WARNING** 

POTENTIAL HAZARD



- Hydraulic fluid escaping under pressure can penetrate skin and cause injury.

WHAT CAN HAPPEN

- Fluid accidentally injected into the skin must be surgically removed within a few hours by a doctor familiar with this form of injury or gangrene may result.

HOW TO AVOID THE HAZARD

- Keep body and hands away from pin hole leaks or nozzles that eject high pressure hydraulic fluid.
- Use cardboard or paper to find hydraulic leaks, never use your hands.

 **CAUTION** 

POTENTIAL HAZARD

- Hydraulic couplers, hydraulic lines/valves, and hydraulic fluid may be hot.

WHAT CAN HAPPEN

- Contact with hot hydraulic components or fluid may cause burns.

HOW TO AVOID THE HAZARD

- Wear gloves when operating the hydraulic couplers.
- Allow the traction unit to cool before touching hydraulic components.
- Do not touch hydraulic fluid spills.

5. If the attachment uses hydraulics, slide the collar back on the hydraulic couplers and disconnect them.
6. Install the protective covers onto the hydraulic couplers on the traction unit.
7. Start the engine, tilt the mount plate forward, and back the traction unit away from the attachment.

Securing the Traction Unit for Transport

IMPORTANT: Do not operate or drive the traction unit on roadways.

IMPORTANT: When transporting the traction unit on a trailer, always use the following procedure:

1. Lower the loader arms.
2. Stop the engine.
3. Set the parking brake.
4. Secure the traction unit to the trailer with chains or straps using the tie-down loops (Fig. 7) to secure the rear of the traction unit and the loader arms/mount plate to secure the front of the traction unit.

7. Push the attachment female connector onto the male connector on the traction unit.
8. Confirm that the connection is secure by pulling on the hoses.
9. Move the auxiliary hydraulics lever to neutral.

Removing an Attachment

1. Lower the attachment to the ground
2. Stop the engine.
3. Disengage the quick attach pins by turning them to the outside.
4. If the attachment uses hydraulics, move the auxiliary hydraulics lever forward, back and forth, and back to neutral to relieve pressure at the hydraulic couplers.

Maintenance

Service Interval Chart

Service Operation	Each Use	8 Hours	25 Hours	100 Hours	200 Hours	400 Hours	Yearly
Engine Oil—check level	X						
Tracks—inspect	X						
Check/tighten all fasteners ³	X						X
Chassis—grease ²		X					
Hydraulic Fluid—check level	Initial		X				
Foam Pre-filter and Paper Air Filter—clean ¹			X				
Engine Oil—change ¹			Initial	X			
Hydraulic lines—check				X			
Battery—check electrolyte				X			
Paper Air Filter—replace ¹				X			
Tracks—adjust tension				X			
Engine Oil Filter—change (every other oil change) ¹					X		
Spark Plug(s)—check					X		
Hydraulic Filter—change		Initial			X		
Fuel Filter—replace					X		
Engine RPM (idle & full throttle)—check						X	
Hydraulic Fluid—change						X	
Gasoline—drain ³							X
Battery—charge, disconnect cables ³	Initial						X
Chipped Surfaces—paint ³							X

¹ More often in dusty, dirty conditions, ² Immediately **after** every washing, ³ Storage Service

CAUTION

POTENTIAL HAZARD

- If you leave the key in the ignition switch, someone could start the engine.

WHAT CAN HAPPEN

- Accidental starting of the engine could seriously injure you or other bystanders.

HOW TO AVOID THE HAZARD

- Remove the key from the ignition switch and disconnect negative battery cable from battery before you do any maintenance.

Accessing the Engine and Internal Components

Before opening any of the covers, stop the engine and remove the key.

Opening the Hood

1. Pull out the hood latch in the front screen (Fig. 17).
2. Swing the hood up until it locks open (Fig. 17).

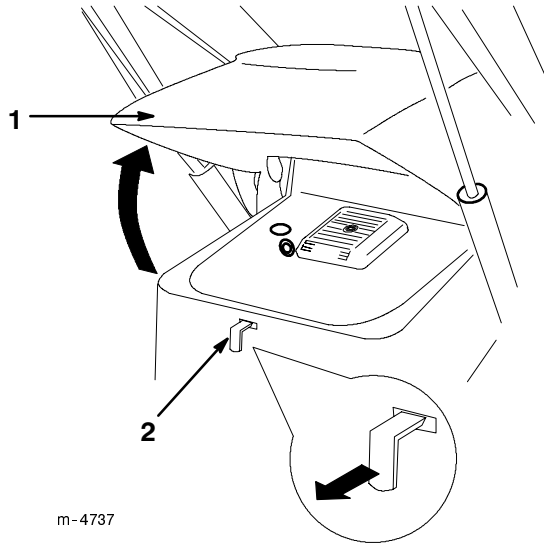

Figure 17

1. Hood
2. Hood latch

Closing the Hood

1. Pull up on the bar securing the hood in the open position and lower the hood (Fig. 18).

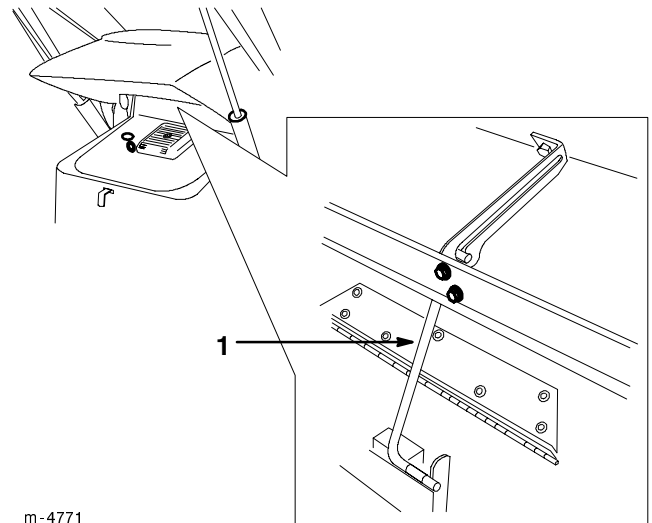

Figure 18

1. Bar

2. Secure the hood by pushing down on the front of the hood until it locks in place.

Opening the Rear Access Cover

1. Pull out and forward on the latch to remove it from the locking bracket on the traction unit frame (Fig. 19).
2. Swing the rear access cover to the right (Fig. 19).

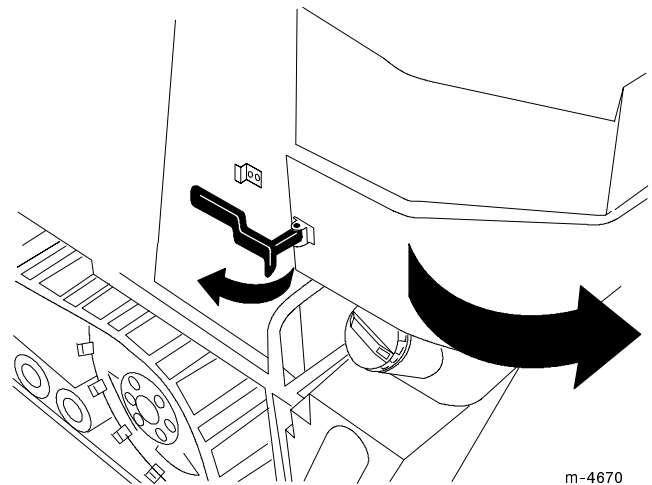

Figure 19

Closing the Rear Access Cover

1. Swing the rear access cover to the left and seat it in place over the back of the traction unit.
2. Place the latch over the locking bracket (Fig. 19).
3. Pull the latch rearward and push it in to lock it in place (Fig. 19).

Removing a Side Screen

1. Open the hood.
2. Pull out and turn the two locking tabs on the inside of the side screen until they line up with the slots in the screen (Fig. 20).

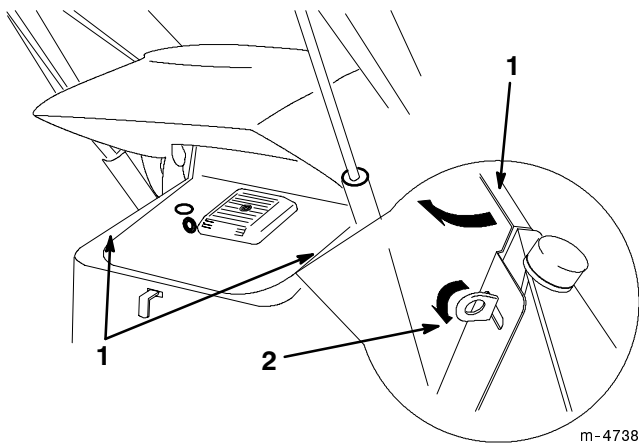

Figure 20

1. Side screen
2. Locking tab

3. Slide the screen inward, off of the tabs and pull it up and out of the engine compartment.

Installing a Side Screen

1. Slide the screen into the engine compartment and line up the holes in the bottom of the screen with the rubber posts in the traction unit frame.
2. Push the screen firmly down over the rubber posts.
3. Slide the slots in the screen over the locking tabs (Fig. 20).
4. Turn the tabs and fold them down to lock the screen in place (Fig. 20).

Removing the Front Screen

1. Open the hood and remove both side screens.

2. Remove the four bolts securing the front screen to the traction unit frame and remove the front screen (Fig. 21).

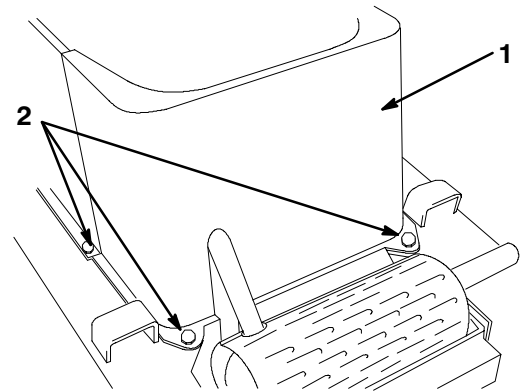

Figure 21

1. Front screen
2. Bolts (left side bolt not shown)

3. Remove the T-handle, shoulder bolts, double washer, and nuts securing the oil cooler to the top of the front screen (Fig. 22).
4. Remove the front screen.

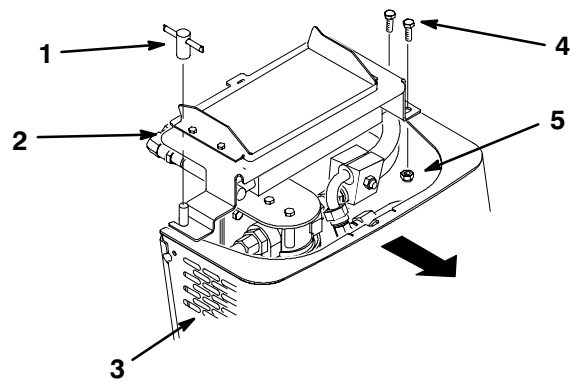

Figure 22

1. T-handle
2. Oil cooler
3. Front screen
4. Shoulder bolts
5. Nut

5. When finished, install the front screen with the four bolts removed previously.
6. Install the oil cooler to the front screen with the two shoulder bolts, double washer, nuts, and T-handle removed previously.
7. Install the side screens and close the hood.

Adjusting the Controls

The factory adjusts the controls before shipping the traction unit. However, after many hours of use, you may need to adjust the neutral position of the traction control, the tracking of the traction control in the full forward position, and the reverse flow stop of the auxiliary hydraulics lever.

Adjusting the Traction Control Neutral Position

If the traction unit creeps forward or backward when the traction control is in neutral and the unit is warm, immediately complete the following procedure:

1. Park the traction unit on a flat surface and lower the loader arms.
2. Stop the engine and remove the key.
3. Lift/support the traction unit so that both tracks are off of the ground.

! WARNING !

POTENTIAL HAZARD

- If you leave the key in the ignition switch, someone could start the engine.

WHAT CAN HAPPEN

- Accidental starting of the engine could seriously injure you or other bystanders.

HOW TO AVOID THE HAZARD

- Remove the key from the ignition switch and disconnect negative battery cable from battery before you do any maintenance.

4. Open the rear access cover; refer to Opening the Rear Access Cover, page 21.
5. Loosen the jam nuts on the traction rods, under the control panel (Fig. 23).

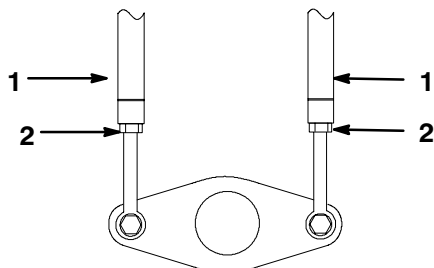

Figure 23

1. Traction rod 2. Jam nut

6. Start the traction unit and set the throttle to about 1/3 open position.

! WARNING !

POTENTIAL HAZARD

- When the traction unit is running, parts are moving and the engine gets hot.

WHAT CAN HAPPEN

- You could be caught in moving parts and injured or burned on hot surfaces.

HOW TO AVOID THE HAZARD

- Take extra care to stay away from pinch points, moving parts, and hot surfaces when adjusting the running traction unit.

7. If the **left** track moves, lengthen or shorten the **right** traction rod until the track stops moving.
8. If the **right** track moves, lengthen or shorten the **left** traction rod until the track stops moving.
9. Tighten the jam nuts.
10. Close the rear access cover.
11. Stop the engine and lower the traction unit to the ground.

Adjusting the Tracking of the Traction Control, Full Forward Position

If the traction unit does not drive straight when you hold the traction control against the reference bar, complete the following procedure:

1. Drive the traction unit with the traction control against the reference bar, noting which direction the traction unit veers.
2. Release the traction control.
3. If the traction unit veers to the **left**, loosen the the **right** jam nut and adjust the tracking set screw on the front of the traction control (Fig. 24).
4. If the traction unit veers to the **right**, loosen the the **left** jam nut and adjust the tracking set screw on the front of the traction control (Fig. 24).

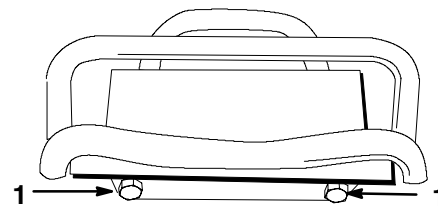

Figure 24

1. Jam nut and set screw

- Repeat steps 1 through 4 until the traction unit drives straight in the full forward position.

Adjusting the Auxiliary Hydraulics Lever, Reverse Flow Stop

In the reverse flow slot of the auxiliary hydraulics lever assembly is a bolt that keeps the lever from going too far into the slot into a detent position (i.e., a position that allows it to stay in the slot without being held by the operator). If the lever goes into a detent position, or if the reverse flow hydraulics speed is slow, adjust the bolt using the following procedure:

- Stop the engine and remove the key.
- Remove the three bolts securing the left control panel cover and remove the cover (Fig. 25).
- Loosen the jam nut on the adjustment bolt (Fig. 25).

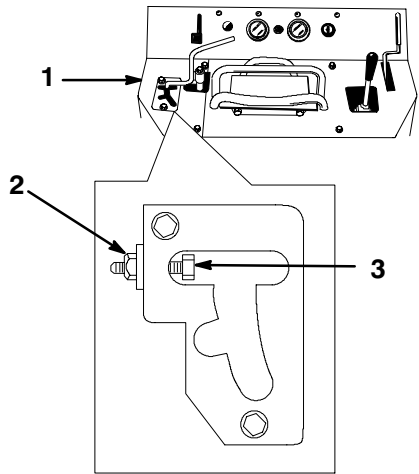

Figure 25

- Left control panel cover
- Jam nut
- Adjustment bolt

- Turn the adjustment bolt clockwise until the lever slips into a detent position.
- Slowly turn the adjustment bolt counter-clockwise until the lever slips out of a detent position.
- Hold the adjustment bolt and tighten the jam nut.
- Install the left panel cover.

Servicing the Air Cleaner

Foam Pre-filter: Clean every 25 operating hours.

Paper Filter: Clean every 25 operating hours. Replace after every 100 operating hours.

Note: Service the air cleaner more frequently if operating conditions are extremely dusty or sandy.

Removing the Foam and Paper Filters

- Lower the loader arms, stop the engine, and remove the key.
- Open the hood; refer to Opening the Hood, page 21.
- Clean around the air cleaner to prevent dirt from getting into the engine and causing damage.
- Unscrew the knob and remove the air cleaner cover (Fig. 26).

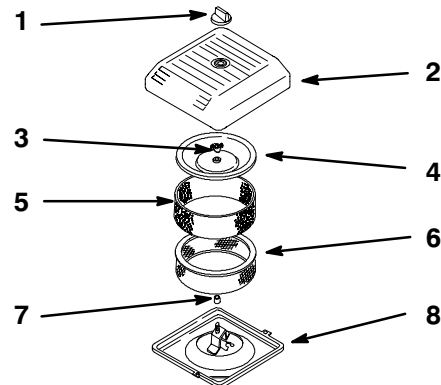

m-4653

Figure 26

- Knob
- Air cleaner cover
- Cover nut
- Cover
- Foam pre-filter
- Paper filter
- Rubber seal
- Air cleaner base

- Carefully slide the foam pre-filter off of the paper element (Fig. 26).
- Unscrew the cover nut and remove the cover and paper filter (Fig. 26).

Cleaning the Filters

IMPORTANT: Replace the foam element if it is torn or worn.

- Wash the foam pre-filter in liquid soap and warm water. When clean, rinse it thoroughly.

2. Dry the pre-filter by squeezing it in a clean cloth (do not wring).
3. Put one or two ounces of oil on the pre-filter (Fig. 27).

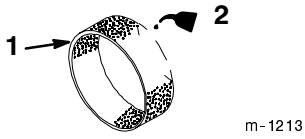

Figure 27

1. Foam element
2. Oil

4. Squeeze the pre-filter to distribute the oil.
5. Lightly tap the paper filter on a flat surface to remove dust and dirt (Fig. 28).
6. Inspect the paper filter for tears, an oily film, and damage to the rubber seal.

IMPORTANT: Never clean the paper element with pressurized air or liquids, such as solvent, gas, or kerosene. Replace the paper element if it is damaged, or cannot be cleaned thoroughly (i.e., after approximately 100 operating hours).

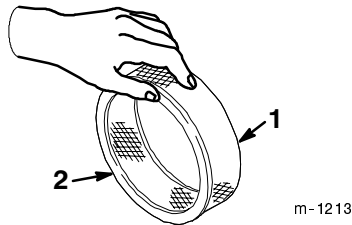

Figure 28

1. Paper element
2. Rubber seal

Installing the Filters

IMPORTANT: To prevent engine damage, always operate the engine with the complete foam and paper air cleaner assembly installed.

1. Carefully slide the foam pre-filter onto the paper filter (Fig. 26).
2. Place the air cleaner assembly onto the air cleaner base (Fig. 26).
3. Install the cover and secure it with the wingnut (Fig. 26).
4. Install the air cleaner cover and secure with the knob (Fig. 26).
5. Close the hood.

Servicing the Engine Oil

Change oil after the first 25 operating hours and then every 100 operating hours thereafter.

Note: Change oil more frequently when operating conditions are extremely dusty or sandy.

Oil Type: Detergent oil (API service SG or SH)

Crankcase Capacity: w/filter, 2.1 qt. (2 l)

Viscosity: See table below

USE THESE SAE VISCOSITY OILS

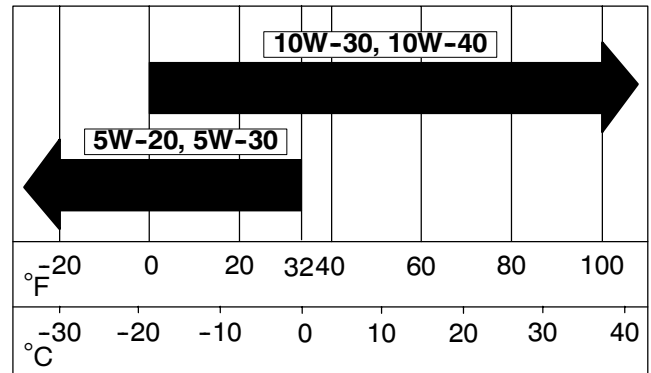

Changing the Oil

1. Start the engine and let it run for five minutes. This warms the oil so it drains better.
2. Park the traction unit so that the drain side is slightly lower than the opposite side to ensure that the oil drains completely.
3. Lower the loader arms, set the parking brake, stop the engine, and remove the key.

⚠
CAUTION
⚠

POTENTIAL HAZARD

- Components will be hot if the traction unit has been running.

WHAT CAN HAPPEN

- Touching hot components can cause burns.

HOW TO AVOID THE HAZARD

- Allow the traction unit to cool before performing maintenance or any touching components.

4. Remove the drain plug (Fig. 29).

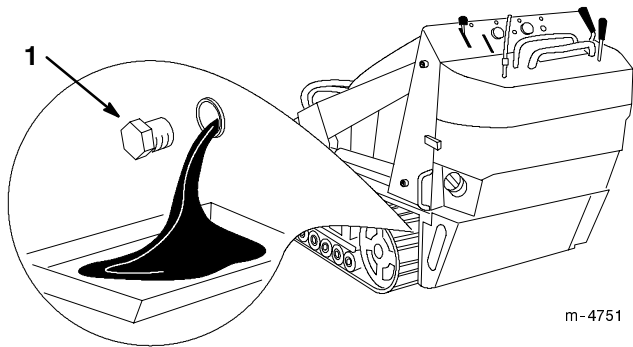

Figure 29

1. Oil drain valve

5. When the oil has drained completely, replace the plug.

Note: Dispose of the used oil at a certified recycling center.

6. Remove the oil fill cap and slowly pour approximately 80% of the specified amount of oil in through the valve cover.
7. Check the oil level; refer to Checking the Oil Level, page 12.
8. Slowly add additional oil to bring the level to the F (full) mark on the dipstick.
9. Replace the fill cap.

Changing the Oil Filter

Replace the oil filter every 200 hours or every other oil change.

Note: Change the oil filter more frequently when operating conditions are extremely hot, dusty, or sandy.

1. Drain the oil from the engine; refer to Changing the Oil, page 25.
2. Place a shallow pan or rag under the filter to catch oil.
3. Remove the old filter (Fig. 30) and wipe the surface of the filter adapter gasket.

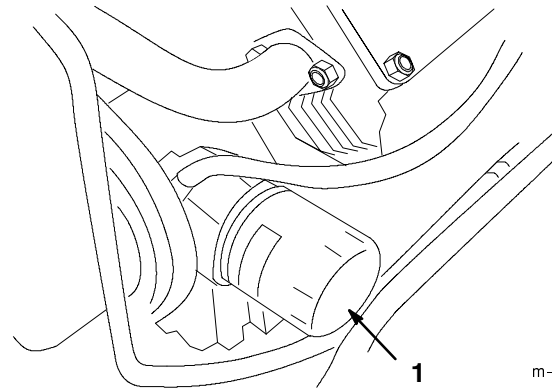

Figure 30

1. Oil filter

4. Pour new oil of the proper type through the center hole of the filter. Stop pouring when the oil reaches the bottom of the threads.
5. Allow a minute or two for the oil to be absorbed by filter material, then pour off the excess oil.
6. Apply a thin coat of new oil to the rubber gasket on the replacement filter.
7. Install the replacement oil filter to the filter adapter. Turn the oil filter clockwise until the rubber gasket contacts the filter adapter, then tighten the filter an additional 1/2 turn.
8. Fill the crankcase with the proper type of new oil; refer to Changing the Oil, page 25.

Servicing the Tracks

Check the tracks for excessive wear and clean them periodically. If the tracks are worn, replace them.

Cleaning the Tracks

1. With a bucket on the loader arms, lower the bucket to the ground so that the front of the traction unit lifts off of the ground a few inches.

2. Stop the engine, and remove the key.
3. Using a water hose or pressure washer, remove dirt from each track system.

IMPORTANT: Ensure that you only use high-pressure water to wash the track area. Do not use a high-pressure washer to clean the rest of the traction unit. High-pressure washing can damage the electrical system and hydraulic valves or deplete grease.

IMPORTANT: Ensure that you fully clean the road wheels, the tension wheel, and the drive sprocket (Fig. 31). The road wheels should rotate freely when clean.

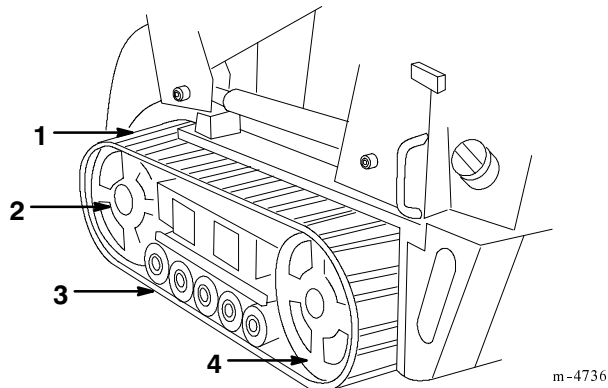

Figure 31

- | | |
|------------------|-------------------|
| 1. Track | 3. Road wheels |
| 2. Tension wheel | 4. Drive Sprocket |

Replacing the Tracks

When the tracks are badly worn, replace them.

1. Lower the loader arms, stop the engine, and remove the key.
2. Lift/support the side of the unit to be worked on so that the track is three to four inches (7.6 to 10 cm.) off of the ground.
3. Remove the locking bolt and nut (Fig. 32).

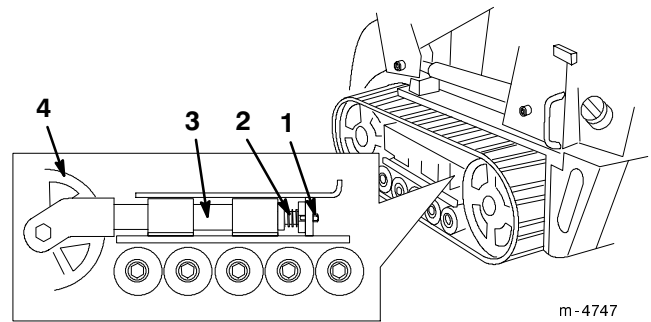

Figure 32

- | | |
|---------------------|------------------|
| 1. Locking bolt | 3. Fork tube |
| 2. Tensioning screw | 4. Tension wheel |

4. Using a 1/2 in. drive socket, release the drive tension by turning the tensioning screw clockwise (Fig. 32 and 33).
5. Push the tension wheel toward the rear of the unit to move the fork tube against the frame (Fig. 33). (If it does not touch the frame, continue turning the tensioning screw until it does.)
6. Begin removing the track at the top of the tension wheel, peeling it off of the wheel while rotating the track forwards.
7. When the track is off of the tension wheel, remove it from the drive sprocket and road wheels (Fig. 33).
8. Beginning at the drive sprocket, coil the new track around the sprocket, ensuring that the lugs on the track fit between the spacers on the sprocket (Fig. 33).

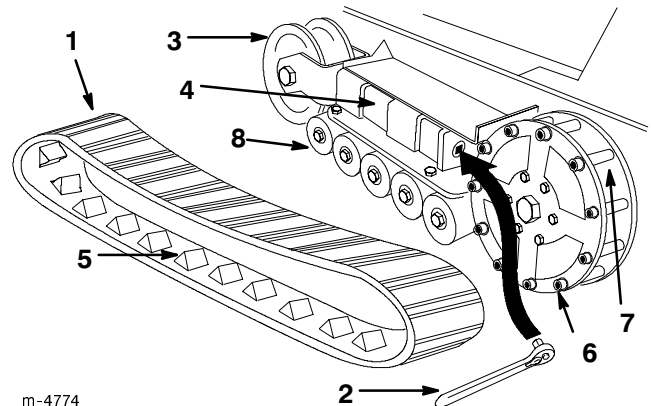

Figure 33

- | | |
|-------------------|--------------------|
| 1. Track | 5. Track lug |
| 2. 1/2 in. socket | 6. Drive sprocket |
| 3. Tension wheel | 7. Sprocket spacer |
| 4. Fork tube | 8. Road wheels |

9. Push the track under and between the road wheels (Fig. 33).
10. Starting at the bottom of the tension wheel, install the track around the wheel by rotating the track rearward while pushing the lugs into the wheel.
11. Turn the tensioning screw counter-clockwise until the distance between the tension nut and the back of the fork tube (Fig. 34) is 2 3/4 in. (7 cm.).

m-4775

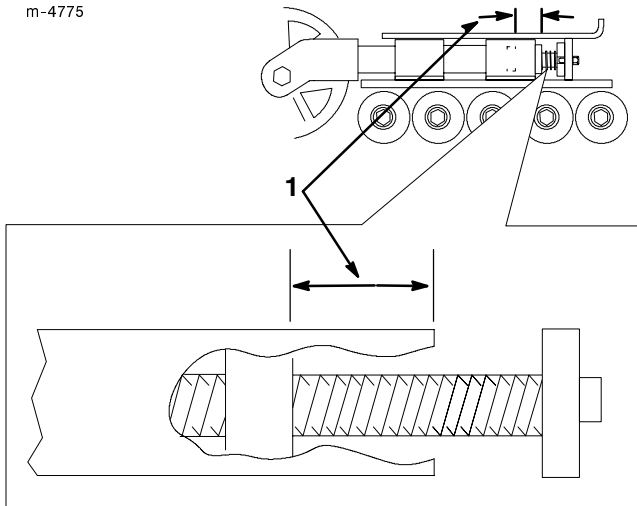

Figure 34

1. 2 3/4 in. (7 cm)

12. Align the closest notch in the tension screw to the locking bolt hole and secure the screw with the locking bolt and nut.
13. Lower the traction unit to the ground.
14. Repeat steps 2 through 13 to replace the other track.

Servicing the Spark Plugs

Check the spark plugs after every 200 operating hours. Ensure that the air gap between the center and side electrodes is correct before installing each spark plug. Use a spark plug wrench for removing and installing the spark plugs and a gapping tool/feeler gauge to check and adjust the air gap. Install new spark plugs if necessary.

Type: Champion RC12YC (or equivalent) Air Gap: 0.030 in. (0.76 mm)

Removing the Spark Plugs

1. Lower the loader arms, stop the engine, and remove the key.
2. Open the hood; refer to Opening the Hood, page 21.
3. Pull the wires off of the spark plugs (Fig. 35).
4. Clean around the spark plugs.
5. Remove both spark plugs and metal washers.

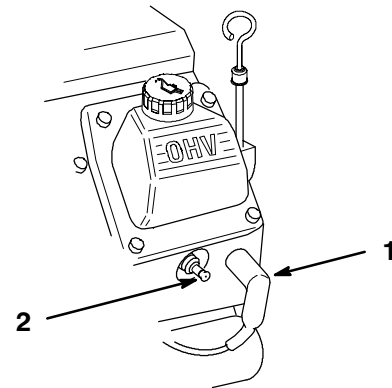

m-3876

Figure 35

1. Spark plug wire
2. Spark plug

Checking the Spark Plugs

1. Look at the center of both spark plugs (Fig. 36). If you see light brown or gray on the insulator, the engine is operating properly. A black coating on the insulator usually means the air cleaner is dirty.

IMPORTANT: Never clean the spark plugs. Always replace the spark plugs when they have a black coating, worn electrodes, an oily film, or cracks.

2. Check the gap between the center and side electrodes (Fig. 36).
3. Bend the side electrode (Fig. 36) if the gap is not correct.

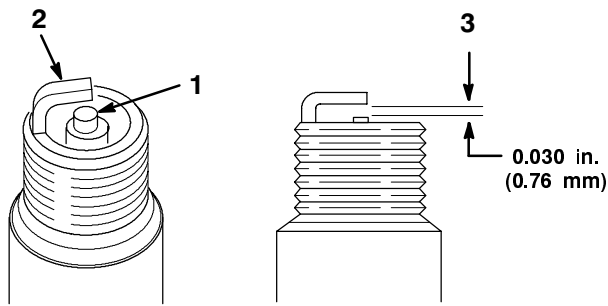

m-3215

Figure 36

1. Center electrode insulator
2. Side electrode
3. Air gap (not to scale)

Installing the Spark Plugs

1. Thread the spark plugs into the spark plug holes.
2. Tighten the spark plugs to 20 ft-lb (27 N.m).
3. Push the wires onto the spark plugs (Fig. 35).
4. Close the hood.

Greasing the Traction Unit

Grease all pivot joints every 8 operating hours and immediately after every washing.

Grease Type: General-purpose grease.

1. Lower the loader arms and stop the engine. Remove the key.
2. Clean the grease fittings with a rag.
3. Connect a grease gun to each fitting (Fig 37 and 38).

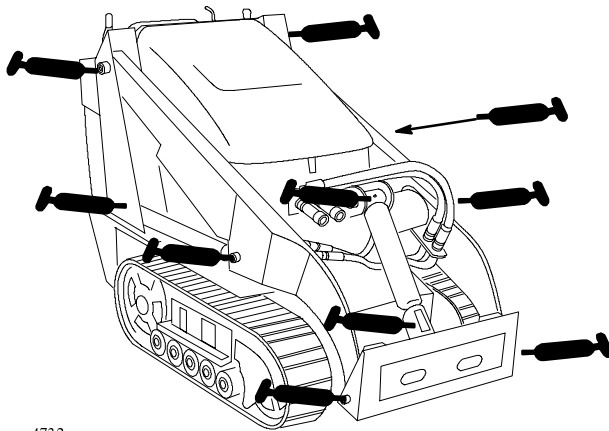

m-4732

Figure 37

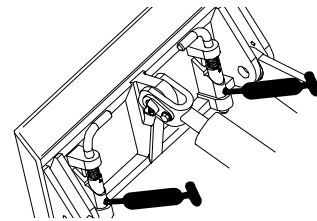

m-4056

Figure 38

4. Pump grease into the fittings until grease begins to ooze out of the bearings (approximately 3 pumps).
5. Wipe up any excess grease.

Changing the Fuel Filter

Change the fuel filter after every 200 operating hours or yearly, whichever occurs first.

Never re-install a dirty filter.

1. Lower the loader arms, stop the engine, and remove the key.
2. Open the hood and remove the left side screen; refer to Accessing the Engine and Internal Components, page 21.
3. Loosen the tank cap to relieve pressure.
4. Clamp the fuel lines on both sides of the fuel filter (Fig. 39).
5. Squeeze the ends of the hose clamps together and slide them away from the filter (Fig. 39).

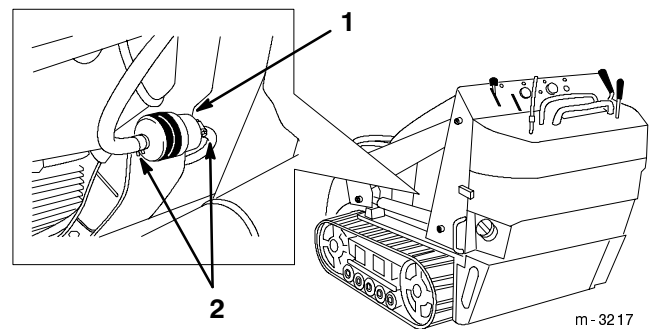

m-3217



Figure 39

1. Filter
2. Hose clamp

6. Place a drain pan under the fuel lines to catch any leaks, then remove the filter from the fuel lines.
7. Loosen the screw securing the fuel filter clamp and slide the filter free of the clamp.
8. Install a new filter in the clamp and tighten the clamp screw to secure it.

9. Slide the fuel line back on the fuel filter fittings and move the hose clamps close to the filter.
10. Remove the clamp blocking fuel flow and open the fuel valves.
11. Secure the tank cap.
12. Replace the side screen and close the hood.

Draining the Fuel Tank

	DANGER	
<p>POTENTIAL HAZARD</p> <ul style="list-style-type: none"> • In certain conditions gasoline is extremely flammable and highly explosive. <p>WHAT CAN HAPPEN</p> <ul style="list-style-type: none"> • A fire or explosion from gasoline can burn you, others, and cause property damage. <p>HOW TO AVOID THE HAZARD</p> <ul style="list-style-type: none"> • Drain gasoline from the fuel tanks when the engine is cold. Do this outdoors in an open area. Wipe up any gasoline that spills. • Do not drain gasoline near an open flame or where gasoline fumes may be ignited by a spark. • Do not smoke while handling fuel. • Do not syphon the fuel by mouth; instead, use a pump type or mechanical syphon. 		

1. Lower the loader arms, stop the engine, and remove the key.
2. Syphon the gasoline from the tank using a pump type syphon.

Note: Now is the best time to install a new fuel filter because the fuel tanks are empty.

Servicing the Hydraulic System

Replacing the Hydraulic Filter

Change the hydraulic filter:

- After the first 8 operating hours.
 - After every 200 operating hours.
1. Position traction unit on a level surface.
 2. Lower the loader arms, stop the engine, and remove the key.
 3. Open the hood, refer to Opening the Hood, page 21.
 4. Remove the front screen, refer to Removing the Front Screen, page 22.

IMPORTANT: Do not substitute an automotive oil filter or severe hydraulic system damage may result.

5. Place a drain pan under the filter (Fig. 40).
6. Remove the old filter (Fig. 40) and wipe the surface of the filter adapter gasket clean.
7. Apply a thin coat hydraulic fluid to the rubber gasket on the replacement filter.
8. Install the replacement hydraulic filter onto the filter adapter (Fig. 40). Tighten it clockwise until the rubber gasket contacts the filter adapter, then tighten the filter an additional 3/4 turn.

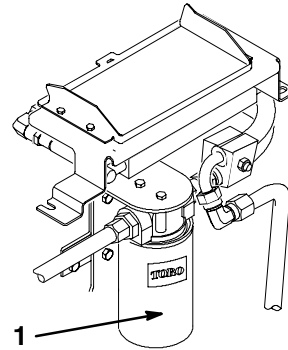



Figure 40

m-5011

1. Hydraulic filter

9. Clean up any spilled fluid.
10. Start the engine and let it run for about two minutes to purge air from the system.
11. Stop the engine and check for leaks.

	WARNING	
<p>POTENTIAL HAZARD</p> <ul style="list-style-type: none"> • Hydraulic fluid escaping under pressure can penetrate skin and cause injury. <p>WHAT CAN HAPPEN</p> <ul style="list-style-type: none"> • Fluid accidentally injected into the skin must be surgically removed within a few hours by a doctor familiar with this form of injury or gangrene may result. <p>HOW TO AVOID THE HAZARD</p> <ul style="list-style-type: none"> • Keep body and hands away from pin hole leaks or nozzles that eject high pressure hydraulic fluid. • Use cardboard or paper to find hydraulic leaks, never use your hands. 		

12. Check the fluid level in the hydraulic tank (refer to Checking the Hydraulic Fluid, page 12) and add fluid to raise the level to mark on dipstick. Do not over fill the tank.

13. Install the front screen, refer to Removing the Front Screen, page 22.

14. Close the hood.

Changing the Hydraulic Fluid

Change the hydraulic fluid after every 400 operating hours or yearly.

1. Position the traction unit on a level surface.
2. Open the hood, refer to Opening the Hood, page 21.
3. Remove the front screen, refer to Removing the Front Screen, page 22.
4. Lower the loader arms, retract the tilt cylinder, stop the engine, and remove the key.
5. Allow the traction unit to cool completely.

IMPORTANT: Do not substitute automotive oil or severe hydraulic system damage may result.

6. Remove the Hydraulic tank cap and dipstick (Fig. 41).
7. Remove the top cover of the hydraulic tank and discard the gasket under the cover (Fig. 41).

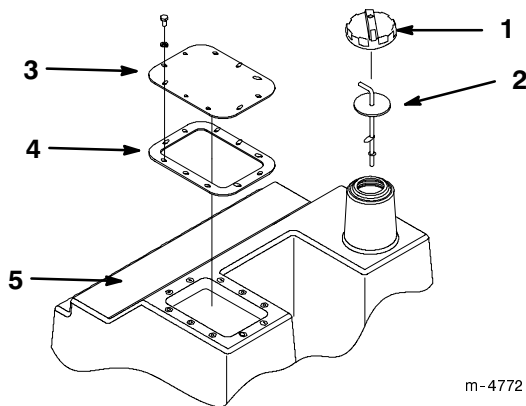

Figure 41

- | | |
|-----------------------|-------------------|
| 1. Hydraulic tank cap | 4. Gasket |
| 2. Dipstick | 5. Hydraulic tank |
| 3. Top cover | |

8. Using a pump type or mechanical syphon, syphon the oil out of the tank.



DANGER



POTENTIAL HAZARD

- Hydraulic oil is poisonous.

WHAT CAN HAPPEN

- If you syphon the oil by mouth, you may ingest the oil or petroleum fumes, resulting in severe illness or death.

HOW TO AVOID THE HAZARD

- Do not syphon the oil by mouth, instead use a pump type or mechanical syphon.

9. Clean the inside of the tank and the outlet screen with a clean, dry cloth.
 10. Install the tank cover with a new gasket (available from your Toro Dealer), and torque the cover bolts to 25 in-lbs (2.8 N·m).
 11. Fill the hydraulic tank with approximately 6 gal. (22.7 l) of Toro Hy-Pro, Mobil Fluid 424, or equivalent (refer to Checking Hydraulic Fluid, page 12).
- Note:** Dispose of used oil at a certified recycling center.
12. Start the engine and let it run for a few minutes.
 13. Stop the engine.
 14. Check the hydraulic fluid level and top it off if necessary (refer to Checking Hydraulic Fluid on page 12).
 15. Install the front screen, refer to Removing the Front Screen, page 22.
 16. Close the hood.

Checking Hydraulic Lines

After every 100 operating hours, check the hydraulic lines and hoses for leaks, loose fittings, kinked lines, loose mounting supports, wear, weather, and chemical deterioration. Replace all moving hydraulic hoses every 1500 hours or 2 years, whichever comes first. Make necessary repairs before operating.



WARNING



POTENTIAL HAZARD

- Hydraulic fluid escaping under pressure can penetrate skin and cause injury.

WHAT CAN HAPPEN

- Fluid accidentally injected into the skin must be surgically removed within a few hours by a doctor familiar with this form of injury or gangrene may result.

HOW TO AVOID THE HAZARD

- Keep body and hands away from pin hole leaks or nozzles that eject high pressure hydraulic fluid.
- Use cardboard or paper to find hydraulic leaks, never use your hands.

Servicing the Battery



WARNING



Battery posts, terminals, and related accessories contain lead and lead compounds, chemicals known to the State of California to cause cancer and reproductive harm. *Wash hands after handling.*

Check the electrolyte level in the battery every 100 hours. Always keep the battery clean and fully charged. Use a paper towel to clean the battery case. If the battery terminals are corroded, clean them with a solution of four parts water and one part baking soda. Apply a light coating of grease to the battery terminals to reduce corrosion.

Voltage: 12 v, 380 Cold Cranking Amps

Checking the Electrolyte Level

1. Open covers to see into the cells. The electrolyte must be up to the lower part of the tube (Fig. 42).

IMPORTANT: Do not allow the electrolyte to get below the plates. (Fig. 42).

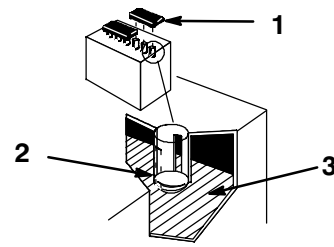

1262

Figure 42

1. Filler caps
2. Lower part of tube
3. Plates

2. If the electrolyte is low, add the required amount of distilled water; refer to Adding Water to the Battery, below.

Adding Water to the Battery

The best time to add distilled water to the battery is just before you operate the traction unit. This lets the water mix thoroughly with the electrolyte solution.

1. Clean the top of the battery with a paper towel.
2. Lift off the filler caps (Fig. 42).
3. Slowly pour distilled water into each battery cell until the level is up to the lower part of the tube (Fig. 42).

IMPORTANT: Do not overfill the battery because electrolyte (sulfuric acid) can cause severe corrosion and damage to the chassis.

4. Press the filler caps onto the battery.

Charging the Battery

IMPORTANT: Always keep the battery fully charged (1.260 specific gravity). This is especially important to prevent battery damage when the temperature is below 32°F (0°C).

1. Check the electrolyte level; refer to Checking Electrolyte Level, page 32.
2. Remove the filler caps from the battery and connect a 3 to 4 amp battery charger to the battery posts. Charge the battery at a rate of 4 amperes or less for 4 hours (12 volts). Do not overcharge the battery.
3. Install the filler caps after the battery is fully charged.

WARNING

POTENTIAL HAZARD

- Charging the battery produces gasses.

WHAT CAN HAPPEN

- Battery gasses can explode.

HOW TO AVOID THE HAZARD

- Keep cigarettes, sparks, and flames away from the battery.

Cleaning the Chassis

Over time, the chassis under the engine collects dirt and debris that must be removed. Using a flashlight, open the hood and inspect the area under the engine on a regular basis. When the debris is one to two inches deep, complete the following procedure (refer to Figure 43 throughout this procedure):

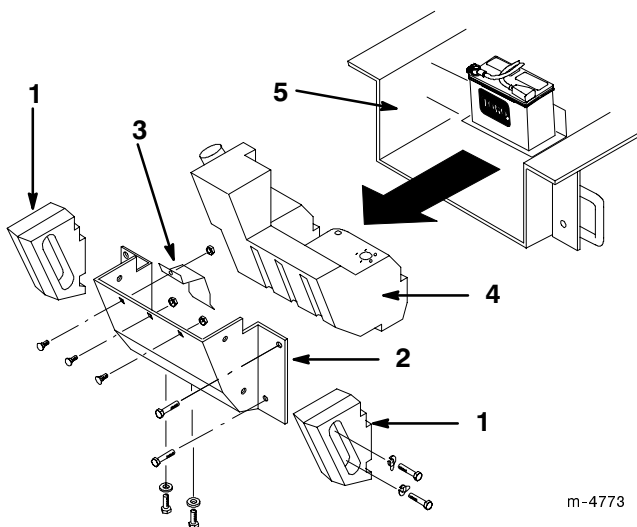

Figure 43

- | | |
|----------------------|--------------|
| 1. Side weights | 4. Fuel tank |
| 2. Rear panel | 5. Chassis |
| 3. Fuel tank bracket | |

1. Lift and support the front of the traction unit.
2. Stop the engine and remove the key.
3. Disconnect the negative battery cable.
4. Remove the bolts, washers, and lock washers securing the two side weights, removing the weights (Fig. 43).
5. Open the rear access cover; refer to Opening the Rear Access Cover, page 21.
6. Remove the three carriage bolts and washers from the battery base and the fuel tank bracket, removing the bracket (Fig. 43).

7. Remove the six nuts and bolts securing the rear panel, removing the panel (Fig. 43).
8. Loosen the tank cap to relieve pressure.
9. Place a clamp on the fuel line, two inches from where it comes out of the fuel tank.
10. Slide the fuel tank to the rear (Fig. 43).
11. Disconnect the fuel line.
12. Disconnect the two wires leading to the right side of the tank (Fig. 44).

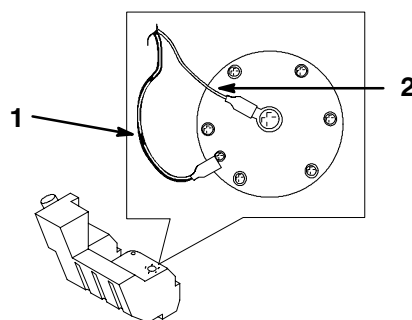

Figure 44

1. Black wire
2. Orange wire

13. Carefully remove the tank and set it upright to keep from spilling the gasoline.

DANGER

POTENTIAL HAZARD

- In certain conditions gasoline is extremely flammable and highly explosive.

WHAT CAN HAPPEN

- A fire or explosion from gasoline can burn you, others, and cause property damage.

HOW TO AVOID THE HAZARD

- Remove the fuel tank outdoors in an open area. Wipe up any gasoline that spills.
- Do not remove the fuel tank near an open flame or where gasoline fumes may be ignited by a spark.
- Do not smoke while handling fuel tank.

14. Remove any large deposits of debris.
 15. Wash out the chassis with water until the water running out the back of the unit is clear.
- IMPORTANT: Take care not to get water into the engine or electrical components.**
16. Slide the fuel tank part way into the chassis (Fig. 43).
 17. Connect the fuel line and remove the clamp.

18. Secure the tank cap.
 19. On the right side of the tank, connect the orange wire to the center post and the black wire to the outside post (Fig. 44).
 20. Slide the tank all the way into the traction unit.
- IMPORTANT: The fuel line and wires must be away from the engine pulleys and the frame.**
21. Replace the rear panel and secure it with the six bolts and nuts removed previously (Fig. 43).
 22. Place the fuel tank bracket over the tank and secure it and the battery tray with the bolts and washers removed previously (Fig. 43).
 23. Install the side weights with the bolts, washers, and lock washers removed previously (Fig. 43).
 24. Close the rear access cover.
 25. Lower the traction unit to the ground.

Storage

1. Lower the loader arms, stop the engine, and remove the key.
 2. Remove dirt and grime from the external parts of the entire traction unit, especially the engine. Clean dirt and chaff from the outside of the engine's cylinder head fins and blower housing.
- IMPORTANT: You can wash the traction unit with mild detergent and water. Do not pressure wash the traction unit. Avoid excessive use of water, especially near the control panel, engine, hydraulic pumps, and motors.**
3. Service the air cleaner; refer to Servicing the Air Cleaner, page 24.
 4. Grease the traction unit; refer to Greasing the Traction Unit, page 29.
 5. Change the crankcase oil; refer to Servicing the Engine Oil, page 25.
 6. Remove the spark plugs and check the condition of each; refer to Servicing the Spark Plugs, page 28.
 7. With the spark plugs removed from the engine, pour two tablespoons of engine oil into each spark plug hole.
 8. Place rags over the spark plug holes to catch any oil spray, then use the starter to crank the engine and distribute the oil inside the cylinder.
 9. Install the spark plugs, but do not install the wires on the spark plugs.
 10. Charge the battery; refer to Servicing the Battery, page 32.

11. For storage over 30 days, prepare the traction unit as follows.

- A. Add a petroleum based stabilizer/conditioner to fuel in the tank. Follow mixing instructions from stabilizer manufacturer. (1 oz. per gallon). **Do not use an alcohol based stabilizer (ethanol or methanol).**

Note: A fuel stabilizer/conditioner is most effective when mixed with fresh gasoline and used at all times.

- B. Run the engine to distribute conditioned fuel through the fuel system (5 minutes).
- C. Stop the engine, allow it to cool and drain the fuel tank using a pump type syphon.
- D. Restart the engine and run it until it stops.
- E. Choke the engine.
- F. Start and run the engine until it will not start again.
- G. Dispose of fuel properly. Recycle as per local codes.

IMPORTANT: Do not store stabilizer/conditioned gasoline over 90 days.

12. Check and tighten all bolts, nuts, and screws. Repair or replace any part that is damaged or defective.
13. Paint all scratched or bare metal surfaces. Paint is available from your Authorized Service Dealer.
14. Store the traction unit in a clean, dry garage or storage area. Remove the key from the ignition switch and keep it in a memorable place.
15. Cover the traction unit to protect it and keep it clean.

Troubleshooting

PROBLEM	POSSIBLE CAUSES	CORRECTIVE ACTION
Starter does not crank	<ol style="list-style-type: none"> 1. Battery is dead. 2. Electrical connections are corroded or loose. 3. Relay or switch is defective. 	<ol style="list-style-type: none"> 1. Charge the battery. 2. Check electrical connections for good contact. 3. Contact Authorized Service Dealer.
Engine will not start, starts hard, or fails to keep running.	<ol style="list-style-type: none"> 1. Fuel tank is empty. 2. Choke is not on. 3. Air cleaner is dirty. 4. Spark plug wires are loose or disconnected. 5. Spark plugs are pitted, fouled, or gap is incorrect. 6. Dirt in fuel filter. 7. Dirt, water, or stale fuel is in fuel system. 	<ol style="list-style-type: none"> 1. Fill fuel tank with gasoline. 2. Move choke lever fully forward. 3. Clean or replace air cleaner element. 4. Install wires on spark plugs. 5. Install new, correctly gapped spark plugs. 6. Replace fuel filter. 7. Contact Authorized Service Dealer.
Engine loses power.	<ol style="list-style-type: none"> 1. Engine load is excessive. 2. Air cleaner is dirty. 3. Oil level in crankcase is low. 4. Cooling fins and air passages under engine blower housing are plugged. 5. Spark plugs are pitted, fouled, or gap is incorrect. 6. Dirt in fuel filter. 7. Dirt, water, or stale fuel is in fuel system. 	<ol style="list-style-type: none"> 1. Reduce ground speed. 2. Clean air cleaner element. 3. Add oil to crankcase. 4. Remove obstruction from cooling fins and air passages. 5. Install new, correctly gapped spark plugs. 6. Replace fuel filter. 7. Contact Authorized Service Dealer.
Engine overheats.	<ol style="list-style-type: none"> 1. Engine load is excessive. 2. Oil level in crankcase is low. 3. Cooling fins and air passages under engine blower housing are plugged. 	<ol style="list-style-type: none"> 1. Reduce ground speed. 2. Add oil to crankcase. 3. Remove obstruction from cooling fins and air passages.
Abnormal vibration.	<ol style="list-style-type: none"> 1. Engine mounting bolts are loose. 	<ol style="list-style-type: none"> 1. Tighten engine mounting bolts.
Traction unit does not drive.	<ol style="list-style-type: none"> 1. The parking brake is on. 2. Hydraulic fluid level low. 3. The tow valves are open. 4. Hydraulic system is damaged. 	<ol style="list-style-type: none"> 1. Release the parking brake. 2. Add hydraulic fluid. 3. Close the tow valves 4. Contact your Toro dealer.



The Toro Dingo® Product Line Warranty

A One-Year Limited Warranty

Conditions and Products Covered

The Toro Company and its affiliate, Toro Warranty Company, pursuant to an agreement between them, jointly warrant your Toro Dingo Product ("Product") to be free from defects in materials or workmanship for one year or 500 operational hours, whichever occurs first. Where a warrantable condition exists, we will repair the Product at no cost to you including diagnosis, labor, and parts. This warranty begins on the date the Product is delivered to the original retail purchaser.

Instructions for Obtaining Warranty Service

Should you feel your Toro Product contains a defect in materials or workmanship, contact the distributor or dealer who sold you the product or any Authorized Dingo Service Dealer. The Yellow Pages of your telephone directory is a good reference source. The dealer will arrange service at his/her dealership. You may need proof of purchase (copy of registration card, sales receipt, etc.) for warranty validation.

If for any reason you are dissatisfied with the Service Dealer's analysis of the defect in materials or workmanship or if you need a referral to a Toro Dingo Service Dealer, please feel free to contact us at:

LCB Customer Service Department
Toro Warranty Company
8111 Lyndale Avenue South
Bloomington, MN 55420-1196
612-888-8801
888-577-7466

Owner Responsibilities

You must maintain your Toro Product by following the maintenance procedures described in the operator's manual. Such routine maintenance, whether performed by a dealer or by you, is at your expense. Parts scheduled for replacement as required maintenance ("Maintenance Parts"), are warranted for the period of time up to the scheduled replacement time for that part. Failure to perform required maintenance and adjustments can be grounds for disallowing a warranty claim.

Items and Conditions Not Covered

Not all product failures or malfunctions that occur during the warranty period are defects in materials or workmanship. This express warranty does not cover:

- Product failures which result from the use of non-Toro replacement parts, or from installation and use of add-on, modified, or unapproved accessories.
- Product failures which result from failure to perform required maintenance and/or adjustments.

Countries Other than the United States or Canada

Customers who have purchased Toro products exported from the United States or Canada should contact their Toro Distributor (Dealer) to obtain guarantee policies for your country, province, or state. If for any reason you are dissatisfied with your Distributor's service or have difficulty obtaining guarantee information, contact the Toro importer. If all other remedies fail, you may contact us at Toro Warranty Company.

- Product failures which result from operating the Product in an abusive, negligent or reckless manner.
- Parts subject to consumption through use unless found to be defective. Examples of parts which are consumed, or used up, during normal Product operation include, but are not limited to, digging teeth, tines, spark plugs, tires, filters, chains, etc.
- Failures caused by outside influence. Items considered to be outside influence include, but are not limited to, weather, storage practices, contamination, use of unapproved coolants, lubricants, additives, or chemicals, etc.
- Normal "wear and tear" items. Normal "wear and tear" includes, but is not limited to, worn painted surfaces, scratched decals or windows, etc.
- Any component covered by a separate manufacturer's warranty.
- Pickup and delivery charges.

General Conditions

Repair by an Authorized Toro Service Dealer is your sole remedy under this warranty.

Neither The Toro Company nor Toro Warranty Company is liable for indirect, incidental or consequential damages in connection with the use of the Toro Products covered by this warranty, including any cost or expense of providing substitute equipment or service during reasonable periods of malfunction or non-use pending completion of repairs under this warranty. Some states do not allow exclusions of incidental or consequential damages, or limitations on how long an implied warranty lasts, so the above exclusions and limitations may not apply to you.

This warranty gives you specific legal rights, and you may also have other rights which vary from state to state.

Except for the Emissions warranty referenced below, if applicable, there is no other express warranty. All implied warranties of merchantability and fitness for use are limited to the duration of this express warranty.

Note to California residents: The Emissions Control System on your Product may be covered by a separate warranty meeting requirements established by the U.S. Environmental Protection Agency (EPA) or the California Air Resources Board (CARB). The hour limitations set forth above do not apply to the Emissions Control System Warranty. Refer to the California Emission Control Warranty Statement printed in your operator's manual or contained in the engine manufacturer's documentation for details.