

TORO GTS 200 OVERHEAD VALVE ENGINE SERVICE MANUAL

Table of Contents – Page 1 of 2

[SPECIFICATIONS](#)

[GENERAL INFORMATION](#)

[OIL](#)

[GASOLINE](#)

[COOLING SYSTEM](#)

[AIR CLEANER – GENERAL](#)

[AIR CLEANER SERVICE](#)

[TUNE-UP PROCEDURE](#)

[OVERHAUL PROCEDURE](#)

[CHECK-UP](#)

[EQUIPMENT AFFECTING ENGINE OPERATION](#)

[IGNITION](#)

[CHECK IGNITION](#)

[SPARK PLUG](#)

[REMOVE FLYWHEEL](#)

[INSPECT FLYWHEEL KEY, KEYWAYS, FLYWHEEL, AND CRANKSHAFT](#)

[INSTALL FLYWHEEL](#)

[SPECIFICATIONS](#)

[CARBURETION](#)

[CARBURETOR IDENTIFICATION](#)

[SERVICE CARBURETOR WALBRO LMS](#)

[GOVERNOR CONTROLS, CARBURETOR LINKAGE, AND FLYWHEEL BRAKE](#)

[REMOTE GOVERNOR CONTROLS](#)

[FLYWHEEL BRAKE](#)

[GOVERNOR ADJUSTMENTS](#)

[GOVERNOR AND CARBURETOR LINKAGES](#)

[GOVERNOR](#)

[GENERAL INFORMATION](#)

[GOVERNED RPM LIMITS](#)

[MECHANICAL GOVERNOR](#)

[COMPRESSION](#)

[TEST COMPRESSION](#)

[REMOVE CYLINDER HEAD](#)

[VALVE SERVICE](#)

[ASSEMBLE CYLINDER HEAD](#)

[SPECIFICATION TABLES](#)

[REWIND STARTER](#)

[GENERAL INFORMATION](#)

[REMOVE BLOWER HOUSING AND STARTER](#)

TORO GTS 200 OVERHEAD VALVE ENGINE SERVICE MANUAL

Table of Contents – Page 2 of 2

[DISASSEMBLE REWIND STARTER](#)

[ASSEMBLE REWIND STARTER](#)

[ELECTRIC STARTER](#)

[GENERAL INFORMATION](#)

[TROUBLESHOOTING 12 VOLT STARTING SYSTEM](#)

[TEST EQUIPMENT](#)

[BATTERY](#)

[STARTER](#)

[ALTERNATOR](#)

[ALTERNATOR SPECIFICATIONS](#)

[EQUIPMENT TO TEST ALTERNATORS](#)

[1/2 AMP ALTERNATOR](#)

[LUBRICATION](#)

[EXTENDED OIL FILL AND DIPSTICK](#)

[BREATHER](#)

[REMOVE BREATHER](#)

[INSTALL BREATHER VALVE](#)

[REMOVE OIL PUMP](#)

[INSPECT OIL PUMP](#)

[INSTALL OIL PUMP](#)

[INSTALL PUMP COVER](#)

[INSTALL OIL FILTER ADAPTER](#)

[PISTONS, RINGS, AND RODS](#)

[PISTON AND CONNECTING ROD](#)

[SPECIFICATION TABLES](#)

[CRANKSHAFT AND CAMSHAFT](#)

[REMOVE CRANKSHAFT AND CAMSHAFT](#)

[INSTALL CRANKSHAFT AND CAMSHAFT](#)

[SPECIFICATION TABLES](#)

[CYLINDER AND BEARINGS](#)

[CYLINDER](#)

[PLAIN OR DU™ BEARINGS](#)

[CRANKCASE SUMP](#)

[SPECIFICATION TABLES](#)

[MUFFLER](#)

[REMOVE EXHAUST SYSTEM](#)

[INSPECT EXHAUST SYSTEM](#)

[INSTALL MUFFLER](#)

[INSTALL MUFFLER GUARD](#)

About This Manual

This manual was written expressly for the Toro GTS 200 Overhead Valve Engine. The Toro Company has made every effort to make the information in this manual complete and correct.

This manual was written with the service technician in mind. We hope that you find this manual a valuable addition to your service shop. If you have questions or comments regarding this manual, please contact us at the following address:

The Toro Company
Consumer Service Department
8111 Lyndale Avenue South
Bloomington, MN 55420-1196

The Toro Company reserves the right to change product specifications or this manual without notice.

The Toro Company gratefully acknowledges the assistance of the Briggs & Stratton Corporation in the production of this manual.

COPYRIGHT – ALL RIGHTS RESERVED
The Toro Company – 1999
Bloomington, MN 55420 – U.S.A

Contents

Specifications	4	Install Inlet Needle and Float	20
General Information	5	High Altitude Compensation	21
Oil	5	Install Carburetor	21
Oil Specifications	5	Install Air Cleaner	21
Check Oil Level	5	Governor Controls, Carburetor Linkage, and Flywheel Brake	22
Change Oil	5	Remote Governor Controls	22
Change Oil—Drain Plug Method	6	Remote Control Wire Travel	22
Change Oil—Oil Fill Tube Method	6	Speed Regulation	22
Approximate Crankcase Oil Capacity (Dry) Specifications	6	Adjust Remote Controls	22
Gasoline	7	Flywheel Brake	22
Cooling System	7	Operation	22
Air Cleaner – General	8	Remove Flywheel Brake	23
Air Cleaner Service	8	Assemble Flywheel Brake	23
Tune-Up Procedure	9	Brake Adjustment	24
Overhaul Procedure	10	Governor Adjustments	24
Check-Up	12	Governor and Carburetor Linkages	24
Check Compression	12	Governor	25
Check Ignition (Using Engine Starter)	12	General Information	25
Check Carburetion	12	Governed RPM Limits	25
Equipment Affecting Engine Operation	12	Mechanical Governor	25
Hard Starting, or Will Not Start	13	Disassemble	25
Vibration	13	Inspect Governor	26
Power Loss	13	Assemble Governor Crank	26
Noise	13	Install Crankcase Cover or Sump	26
Ignition	14	Adjust Top No Load RPM	26
Check Ignition	14	Seal Protectors	26
Check For Spark Miss	14	Compression	27
Spark Plug	15	Test Compression	27
Spark Plug Maintenance	15	Remove Cylinder Head	28
Remove Ignition Armature	15	Prepare Cylinder Head for Removal	28
Remove Flywheel	15	Remove Rocker Cover	28
Inspect Flywheel Key, Keyways, Flywheel, and Crankshaft	16	Remove Cylinder Head	28
Install Flywheel	16	Remove Valves	29
Install Flywheel	16	Inspect Valve Guides	29
Install Ignition Armature	16	Valve Service	29
Adjust Ignition Armature Air Gap	17	Reface Valves and Seats	29
Specifications	17	Assemble Cylinder Head	29
Carburetion	18	Install Cylinder Head Plate and Rocker Arm Studs ..	29
Carburetor Identification	18	Install Valves	30
Service Carburetor Walbro LMS	18	Install Valve Springs and Retainers	30
Remove Air Cleaner	18	Install Cylinder Head	30
Remove Carburetor	19	Install Rocker Arms—Current Style	30
Disassemble Carburetor	19	Install Rocker Arms—Early Style	31
Carburetor Cleaning Recommendations	20	Adjust Valve Clearance—Current Style	31
Assemble Carburetor	20	Adjust Valve Clearance—Early Style	31
Install Welch Plug	20	Install Valve Cover	32
Install Throttle Shaft	20	Specification Tables	32
Install Inlet Needle Seat	20	Rewind Starter	33
		General Information	33
		Remove Blower Housing and Starter	33
		Disassemble Rewind Starter	34

Remove Rope	34	Install Oil Pump	48
Inspect Rope	34	Install Pump Cover	48
Remove Pulley And Spring	35	Install Oil Filter Adapter	48
Inspect Spring, Starter Housing and Pulley	35	Pistons, Rings, and Rods	49
Assemble Rewind Starter	36	Piston and Connecting Rod	49
Install Pulley and Spring	36	Remove Piston and Connecting Rod	49
Install Pawls and Retainer Assembly	36	Remove Piston Rings	49
Wind Spring and Install Rope	36	Check Piston Ring Groove Wear	50
Install Rewind Starter on Blower Housing	37	Check Piston Ring End Gap	50
Install Blower Housing and Rewind Starter	37	Check Connecting Rod	50
Install Fuel Tank	37	Check Piston Pin and Piston Pin Bore	50
Electric Starter	38	Assemble Piston and Connecting Rod	50
General Information	38	Install Piston Rings On Piston	51
Troubleshooting 12 Volt Starting System	38	Compress Rings	51
Test Equipment	39	Install Connecting Rod and Piston	51
Digital Multimeter	39	Specification Tables	52
DC Shunt	39	Crankshaft and Camshaft	53
Tachometer	39	Remove Crankshaft and Camshaft	53
Starter Test Bracket	39	Remove Crankshaft	53
Other Equipment	39	Inspect Crankshaft	53
Battery	40	Inspect Camshaft	54
Handling Instructions	40	Check Compression Release	54
First Aid	40	Install Crankshaft and Camshaft	54
Check Battery	40	Install Crankshaft	54
Replace Battery Terminal	40	Install Camshaft	54
Starter	41	Install Crankcase Sump	54
Check Starter Motor Drive and Clutch	41	Adjust Crankshaft End Play	55
Wiring Diagrams	41	Specification Tables	55
Check 12 Volt Starter Motor	41	Cylinder and Bearings	56
Starter Motor Specifications	41	Cylinder	56
Troubleshoot Starter Motor	41	Inspection	56
Check Brake Switch	42	Cylinder Finish (Cross Hatch)	56
Check Brake Switch Wiring	42	Cylinder Cleaning	56
Disassemble Starter Motor	42	Check Plain or DU™ Bearings	57
Clean and Inspect Starter	43	Check Camshaft Bearings	57
Assemble Starter Motor	43	Plain or DU™ Bearings	57
Install Starter	44	Repair Worn Aluminum Bearings	57
Alternator	45	Remove DU™ Magneto Bearing	57
Alternator Specifications	45	Install Magneto DU™ Bushing	57
Equipment to Test Alternators	45	Oil Seals	58
Digital Multimeter	45	Crankcase Sump	58
1/2 Amp Alternator	45	Install	58
Test Alternator Output	45	Specification Tables	58
Install Stator Studs	46	Muffler	59
Adjust Stator Air Gap	46	Remove Exhaust System	59
Lubrication	47	Inspect Exhaust System	59
Extended Oil Fill and Dipstick	47	Install Muffler	60
Breather	47	Install Muffler Guard	60
Remove Breather	47		
Install Breather Valve	47		
Remove Oil Pump	47		
Inspect Oil Pump	48		

Specifications

Basic model series	123600
Oil capacity	22 fl. oz. (.65 Liter) 26 fl. oz. (.78 Liter) with oil filter
Armature air gap006/.014 in. 0.15/0.36mm

Torque specifications

Flywheel nut	60 ft. lb. 81.0Nm
Cylinder head	210 in. lb. 24.0Nm
Connecting rod	100 in. lb. 11.0Nm
Crankcase cover or sump	110 in. lb. 12Nm

Valve clearance

Intake004/.008 in. 0.10/0.20mm
Exhaust004/.008 in. 0.10/0.20mm

Crankshaft

Stroke	2.040 in. 51.81mm
Standard crankpin journal	1.0983/1.0991 in. 27.897/27.917mm

Journal reject sizes

Magneto878 in. 22.30mm
Crankpin	1.097 in. 27.86mm
PTO	1.065 in. 27.05mm
End play002/.033 in. 0.05/0.84mm

Engine RPM (no load)	3,000 RPM \pm 150
----------------------------	---------------------

Spark plug

Type	Champion RC12YC
Gap	0.020 in. 0.51mm

General Information

Contents

Oil	5
Oil Specifications	5
Check Oil Level	5
Change Oil	5
Change Oil—Drain Plug Method	6
Change Oil—Oil Fill Tube Method	6
Approximate Crankcase Oil Capacity (Dry) Specifications	6
Gasoline	7
Cooling System	7
Air Cleaner – General	8
Air Cleaner Service	8
Tune-Up Procedure	9
Overhaul Procedure	10
Check-Up	12
Check Compression	12
Check Ignition (Using Engine Starter)	12
Check Carburetion	12
Equipment Affecting Engine Operation	12
Hard Starting, or Will Not Start	13
Vibration	13
Power Loss	13
Noise	13

Oil

Oil Specifications

Service classification ... SF, SG, SH, or SI

Viscosity grade SAE 30

Oil capacity 22 fl. oz. (.65 Liter)
26 fl. oz. (.78 Liter) with filter

Check oil before each use or every five hours.

Change oil after the first five hours; thereafter, every 50 operating hours or every season.

Change filter on models so equipped, every 100 operating hours or yearly, whichever occurs first.

Check Oil Level

Fill crankcase with SAE 30 oil until oil level reaches FULL mark on dipstick as shown in Figure 1. The maximum crankcase capacity is 22 ounces (0.65 Liter). On models equipped with an oil filter, the maximum crankcase capacity is 26 ounces (0.78 Liter). Use any high quality detergent oil having the American Petroleum Institute (API) “service classification”—SF, SG SH, or SJ.

Before each use or every five hours, ensure oil level is between ADD and FULL marks on dipstick (Fig. 1). Add oil if level is low.

1. Position mower on level surface and clean around oil dipstick.
2. Remove dipstick by rotating cap counterclockwise 1/4 turn (Fig. 1).
3. Wipe dipstick and insert it into oil fill tube. Rotate cap clockwise 1/4 turn. Then remove dipstick and check level of oil (Fig. 1). If level is low, add only enough oil to raise level to FULL mark on dipstick. **DO NOT FILL ABOVE FULL MARK BECAUSE ENGINE COULD BE DAMAGED WHEN STARTED. POUR OIL SLOWLY.**
4. Insert dipstick into oil fill tube and rotate cap clockwise 1/4 turn to lock (Fig. 1).

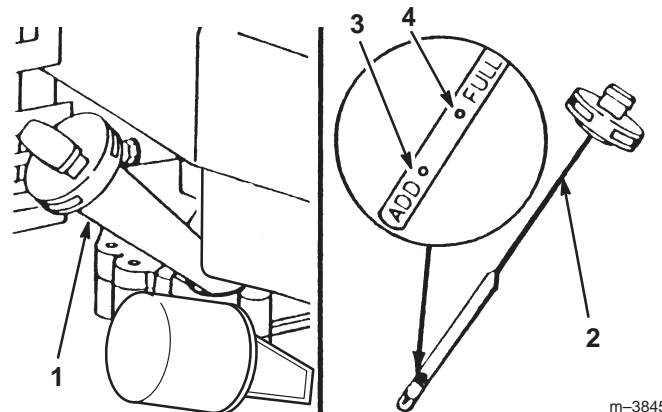

Fig. 1 – Checking Oil Level

- | | |
|------------------|--------------|
| 1. Oil fill tube | 3. ADD mark |
| 2. Dipstick | 4. FULL mark |

Change Oil

Change the oil after the first 5 operating hours. Thereafter, change the oil every 50 operating hours or every season. More frequent oil changes are required when operating engine under a heavy load, or when used in dusty, dirty, or hot conditions.

Replace the oil filter (on models so equipped) every 100 hours or yearly, whichever occurs first.

There are two methods of changing engine oil, the drain plug method and the oil fill tube method. Both work equally well.

Change Oil—Drain Plug Method

1. Run engine at least 5 minutes to warm the oil. Warm oil drains more easily and more of the contaminants are removed.
2. Remove oil drain plug (Fig. 2). Drain oil into a pan.

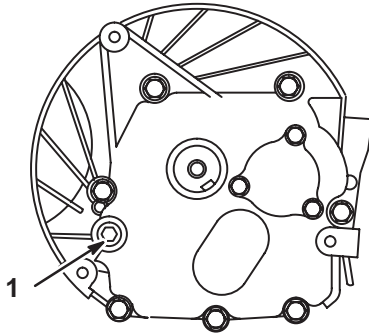

Fig. 2 – Drain Plug Location

1. Oil drain plug

3. If replacing the oil filter (on models so equipped), do so at this time.
4. Install drain plug snugly.
5. Remove dipstick and refill slowly with new oil of proper service classification and viscosity grade.
6. Start and run engine at idle. Check for oil leaks.
7. Stop engine. Recheck oil level and add oil if required.

Change Oil—Oil Fill Tube Method

1. Stop engine and wait for all moving parts to stop. Pull wire off spark plug.
2. Remove grass bag. Drain gasoline from fuel tank.
3. Remove dipstick from oil fill tube and place a drain pan next to left side of mower.
4. Tip mower on its left side, allowing oil to drain into drain pan (Fig. 3).

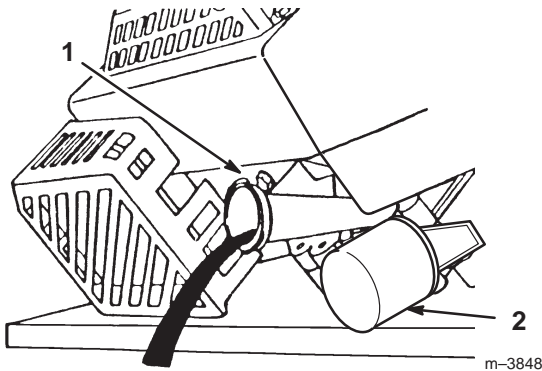

Fig. 3

1. Oil fill tube
2. Oil filter

5. If replacing the oil filter (on models so equipped), do so at this time.
6. When oil is drained, return mower to upright position and add fresh oil to engine. Refer to Oil in this section.

Approximate Crankcase Oil Capacity (Dry) Specifications

Without oil filter	22 oz.
	.65 Liter
With oil filter	26 oz.
	.78 Liter

Change Oil Filter (on models so equipped)

Change filter every 100 hours. Before installing new filter, lightly oil filter gasket with fresh clean engine oil. Screw filter clockwise by hand until gasket contacts filter adapter. Tighten 1/2 to 3/4 turn farther. Add fresh oil. Then, start and run engine at idle for 30 seconds and stop engine. Recheck oil level and add oil if required. Restart engine and check for oil leaks, Fig. 4.

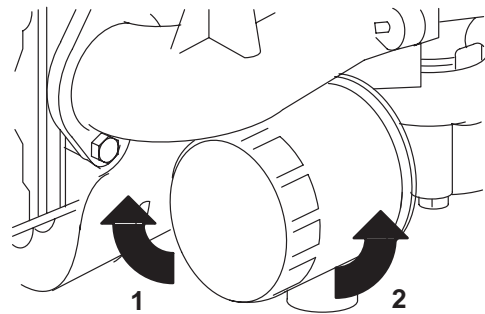

Fig. 4 – Remove and Install Oil Filter



1. Install
2. Remove

Gasoline

Use clean, fresh, lead-free gasoline (including *oxygenated* or *reformulated* gasoline) with an octane rating of 87 or higher. To ensure freshness, purchase only the quantity of gasoline that can be used in 30 days. Using unleaded gasoline results in fewer combustion chamber deposits and longer spark plug life.

Engines certified to comply with California and U.S. EPA emission regulations for ULGE engines are certified to operate on regular unleaded gasoline, include EM and TWC (if so equipped) emission control systems, and do not include any user adjustable features.

IMPORTANT: Do not use methanol, gasoline containing methanol, gasohol containing more than 10% ethanol, premium gasoline, or white gas. Using these fuels can damage the engine's fuel system.

 **DANGER** 

POTENTIAL HAZARD



- In certain conditions gasoline is extremely flammable and highly explosive.

WHAT CAN HAPPEN

- A fire or explosion from gasoline can burn you, others, and cause property damage.

HOW TO AVOID THE HAZARD

- Use a funnel and fill the fuel tank outdoors, in an open area, when the engine is cold. Wipe up any gasoline that spills.
- Do not fill the fuel tank completely full. Add gasoline to the fuel tank until the level is 1/4" to 1/2" (6 mm to 13 mm) below the bottom of the filler neck. This empty space in the tank allows gasoline to expand.
- Never smoke when handling gasoline, and stay away from an open flame or where gasoline fumes may be ignited by a spark.
- Store gasoline in an approved container and keep it out of the reach of children.
- Never buy more than a 30-day supply of gasoline.

 **DANGER** 

POTENTIAL HAZARD

- When fueling, under certain circumstances, a static charge can develop, igniting the gasoline.

WHAT CAN HAPPEN

- A fire or explosion from gasoline can burn you and others and cause property damage.

HOW TO AVOID THE HAZARD

- Always place gasoline containers on the ground away from your vehicle before filling.
- Do not fill gasoline containers inside a vehicle or on a truck or trailer bed because interior carpets or plastic truck bed liners may insulate the container and slow the loss of any static charge.
- When practical, remove gas-powered equipment from the truck or trailer and refuel the equipment with its wheels on the ground.
- If this is not possible, then refuel such equipment on a truck or trailer from a portable container, rather than from a gasoline dispenser nozzle.
- If a gasoline dispenser nozzle must be used, keep the nozzle in contact with the rim of the fuel tank or container opening at all times until fueling is complete.

Use a fuel stabilizer/conditioner regularly during operation and storage. A stabilizer/conditioner cleans the engine during operation and prevents gum-like varnish deposits from forming in the engine during storage.

IMPORTANT: Do not use fuel additives other than a fuel stabilizer/conditioner. Do not use fuel stabilizers with an alcohol base such as ethanol, methanol, or isopropanol.

1. Clean the area around the fuel tank cap.
2. Remove the cap from the fuel tank.
3. Using unleaded, regular gasoline, fill the tank to within 1/4 to 1/2 in. (6 to 13mm) from the top of the tank.

IMPORTANT: Do not fill the tank with gasoline into the filler neck. This space is for expansion of fuel. Do not fill the tank completely full.

4. Install the fuel tank cap.
5. Wipe up any spilled gasoline.

Cooling System

Grass particles, chaff, or dirt can clog the air cooling system, especially after prolonged service in very dusty conditions or when cutting dry grass. Continued operation with a clogged cooling system can cause severe overheating and possible engine damage. Figures 5 and 6 show the areas to be cleaned.

This should be a regular maintenance operation, performed yearly or every 100 hours, whichever comes first and more often when dust or when airborne debris is present.

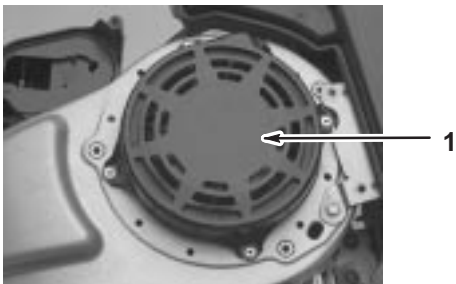

Fig. 5 – Static Screen

1. Static screen

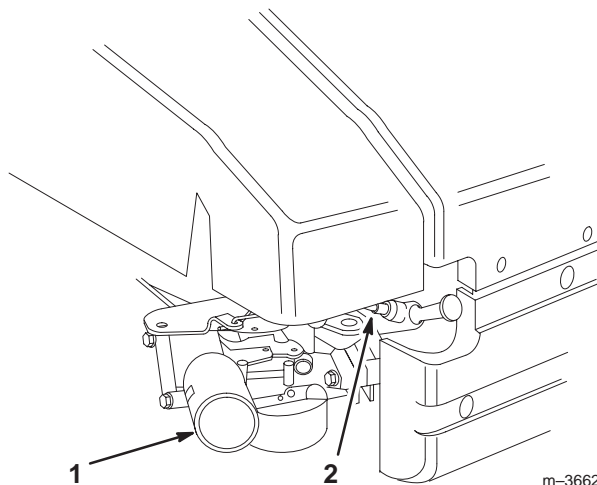

Fig. 7 – Remove Spark Plug Wire Prior to Service

1. Primer
2. Spark plug wire

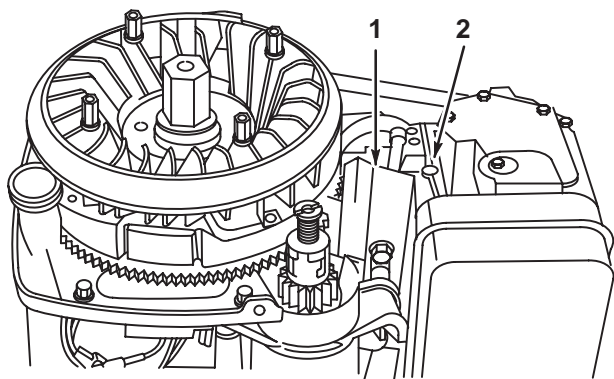

Fig. 6 – Cylinder Fins and Ducting

1. Ducting
2. Cylinder fins

Air Cleaner – General

A properly serviced air cleaner protects internal parts of the engine from dust particles in the air. If air cleaner instructions are not carefully followed, dirt and dust which should be collected in the air cleaner will be drawn into the engine and become a part of the oil film, which is very detrimental to engine life; dirt in the oil forms an abrasive mixture which wears moving parts instead of protecting them.

Air Cleaner Service

Normally, clean the air cleaner pre-cleaner after every 25 operating hours or every season. Clean or replace the paper cartridge after every 100 hours or every season. More frequent cleaning is required when mower is operated in dusty or dirty conditions. Replace air cleaner parts, if very dirty.

IMPORTANT: Do not operate engine without air filter elements; extreme engine wear or damage will occur.

Note: Tipping mower on wrong side to service underside of mower may cause damage to air filters.

1. Stop engine and pull wire off spark plug (Fig. 7).

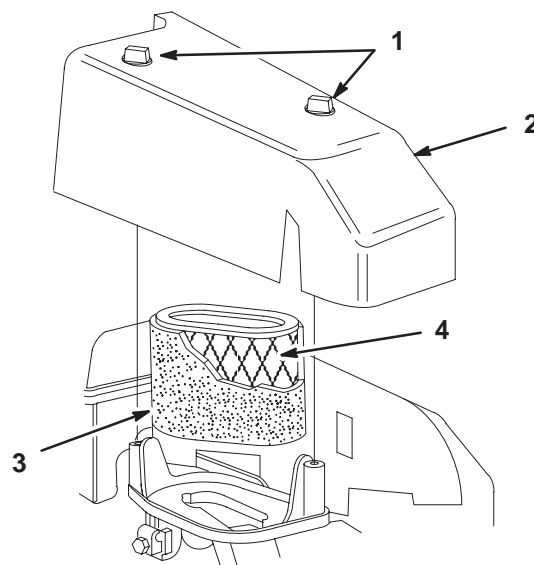

Fig. 8 – Air Cleaner Service

1. Knob
2. Cover
3. Foam pre-cleaner
4. Paper cartridge

3. Lift cover off. Clean cover thoroughly.
4. Carefully remove pre-cleaner. If pre-cleaner is dirty, carefully wash it in a solution of liquid soap and warm water. Rinse in clear water. Allow to dry thoroughly before using.
5. If paper cartridge is dirty, clean the paper filter by tapping it **gently** on a flat surface. If very dirty, replace cartridge.

IMPORTANT: Do not oil pre-cleaner or paper cartridge. Do not use pressurized air to clean paper cartridge.

6. Reinstall pre-cleaner over paper cartridge. Reinstall air cleaner cover and tighten securely in place with two (2) knobs.

Tune-Up Procedure

By performing the following steps you will either be sure that the engine is functioning properly or will know what repairs should be made.

These steps are also covered in the Overhaul Procedure and will normally be performed as a part of complete overhaul.

Carbon deposits in combustion chamber should be removed every 100 to 300 hours of use (more often when run at steady loads), or whenever cylinder head is removed.

Step No.

1.	Remove air cleaner, check for proper servicing. Replace if damaged or dirty.
2.	Check oil level and drain oil.
3.	Remove blower housing, inspect rewind assembly.
4.	Clean cooling fins and entire engine.
5.	Remove carburetor, disassemble, and inspect for wear or damage. Wash in solvent. Replace parts as necessary and assemble. Set initial adjustment.
6.	Inspect intake elbow or carburetor spacer for damaged gaskets.
7.	Check governor, linkage, and springs for damage, wear, also check adjustment.
8.	Clean fuel tank and lines.
9.	Remove flywheel. Check for oil seal leakage, both flywheel and PTO sides. Check flywheel key.
10.	Check armature coil. Inspect all wires for breaks and/or damaged insulation. Be sure lead wires do not touch flywheel. Check stop switch and lead(s).
11.	Remove oil, debris, and nicks from flywheel and crankshaft tapers.
12.	Install flywheel and set air gap. Check for spark with Briggs & Stratton Tool #19051 or #19368 ignition tester.
13.	Remove spark plug and cylinder head.
14.	Inspect valves for seating.
15.	Clean carbon from cylinder head and piston.
16.	Replace gaskets and install cylinder head. Tighten to specified torque. Adjust valve clearance. Set spark plug gap or replace plug if necessary.
17.	Replace gaskets and install carburetor
18.	Adjust remote control linkage and cable, if used, for correct operation.
19.	Check muffler for restrictions or damage.
20.	Replace oil and fuel.
21.	Run engine and adjust carburetor mixture and engine Top No Load RPM.

Overhaul Procedure

The Overhaul Procedure which follows is intended to help you become accustomed to a systematic method of repairing Toro GTS 200 OHV engines. Naturally these steps could be rearranged in different order but efficiency is obtained when the repair operations are performed in the same sequence every time.

The Overhaul Procedure can also be used as an index. For information on how to perform most operations listed, refer to the section number or operation.

Disassemble	Section	Beginning Page
Check compression	Compression	27
Drain oil – Remove oil filter (when equipped)	Lubrication	47
Air cleaner	General Information	5
Fuel line, tank assembly and brackets, carburetor and linkage, carburetor intake manifold or spacer	Carburetion	18
Exhaust manifold, muffler	Muffler	59
Disassemble carburetor	Carburetion	18
Electric starter (12 V) Blower housing	Electric Starter	38
Breather and valve cover	Lubrication	47
Valves and springs, rocker arms, push rods, cylinder head and shields, valve guides and seats	Compression	27
Rewind starter	Rewind Starter	33
Flywheel	Ignition	14
Check crankshaft end play	Crankshaft and Camshaft	53
Remove burrs from crankshaft extension	Crankshaft and Camshaft	53
Crankcase cover or sump	Crankshaft and Camshaft	53
Mechanical governor parts	Governor	25
Cam gear and tappets	Crankshaft and Camshaft	53
Connecting rod and piston	Pistons, Rings, and Rods	49
Crankshaft	Crankshaft and Camshaft	53

Inspection	Section	Beginning Page
Inspect carburetor choke, throttle shaft, and bushings for wear and freedom of movement	Carburetion	18
Inspect and test ignition coil	Ignition	14
Crankshaft – inspect and check	Crankshaft and Camshaft	53
Oil pump – inspect and check, if so equipped	Lubrication	47
Cylinder – check bore, main bearing	Cylinder and Bearings	56
Check piston, rings, connecting rod, and piston pin	Pistons, Rings, and Rods	49

Repairs	Section	Beginning Page
Clean/replace parts as required		
Replace block or short block if cylinder is over allowable dimension	Cylinder and Bearings	56
Replace valve guides – intake or exhaust, if required	Compression	27
Reface valves and seats and lap, if required	Compression	27
Replace ignition armature, if required	Ignition	14
Replace throttle shaft bushings, if required	Carburetion	18
Repair carburetor	Carburetion	18
Replace rewind starter spring and rope (if so equipped)	Rewind Starter	33
Replace main bearings and seals, if required	Cylinder and Bearings	56

Reassemble	Section	Beginning Page
Crankshaft	Crankshaft and Camshaft	53
Piston, piston pin, connecting rod, and rings	Pistons, Rings, and Rods	49
Tappets, cam gear	Crankshaft and Camshaft	53
Oil pump, if so equipped	Lubrication	47
Mechanical governor	Governor	25
Crankcase cover or sump	Crankshaft and Camshaft	53
Breather	Lubrication	47
Flywheel, starter cup, and fan	Ignition	14
Ignition armature assembly	Ignition	14
Adjust ignition armature to flywheel air gap	Ignition	14
Check spark	Ignition	14
Electric starter (12 V)	Electric Starter	38
Valves, valve stem seals, springs, retainers, rocker arms	Compression	27
Cylinder head and push rods	Compression	27
Adjust valve clearance	Compression	27
Valve cover	Compression	27
Spark plug – adjust gap to .020"	Ignition	14
Exhaust manifold, mufflers	Muffler	59
Intake manifold	Carburetion	18
Carburetor and linkage and governor controls	Governor Controls, Carburetor Linkage, and Flywheel Brake	22
Check and adjust mechanical governor	Governor	25
Blower housing and rewind starter	Ignition	14
Fuel filter, tank, and line	Carburetion	18
Clean/replace and assemble air cleaner	General Information	5
Fill crankcase with oil, fill with gas, start engine	General Information	5
Adjust carburetor	Carburetion	18
Set governor to obtain correct engine speed (remote controls)	Governor	25
Spray paint engine parts and apply decals		

Check-Up

Most complaints concerning engine operation can be classified as one or a combination of the following:

1. Will not start
2. Hard starting
3. Lack of power
4. Vibration
5. Overheating
6. High oil consumption

When the cause of malfunction is not readily apparent, perform a check of the compression, ignition, and carburetion systems. This check-up, performed in a systematic manner, can usually be done in a matter of minutes. It is the quickest and surest method of determining the cause of failure. This check-up will point out possible cause of future failures, which can be corrected at the time. The basic check-up procedure is the same for all engine models, while any variation, by model, will be shown under the subject heading.

Check Compression

See the section Compression for proper procedure.

If compression is poor, look for –

1. Loose spark plug
2. Loose cylinder head bolts
3. Blown head gasket
4. Burned valves, valve seats
5. Insufficient valve clearance
6. Warped cylinder head or warped valve cover
7. Warped or worn valve stems and guides
8. Worn bore and/or rings
9. Broken connecting rod

Check Ignition (Using Engine Starter)



WARNING



BE SURE there is no fuel or fuel vapor present, which might be ignited by the spark and cause a fire or explosion.

Attach a spark tester to spark plug wire and ground the other end of the tester to the engine block. Warning: Do not remove spark plug. Spin the flywheel with the engine starter. If spark jumps the .166" (4.20mm) tester gap, you can assume the ignition system is performing satisfactorily. See the section Ignition for additional information.

If spark does not occur, look for –

1. Shorted stop switch wire
2. Shorted stop switch
3. Ignition armature failure
4. Improperly operating interlock system

Note: If engine runs but misses during operation, a quick check to determine if ignition is or is not at fault can be made by inserting the spark tester between the ignition cable and the spark plug. A spark miss will be readily seen. See the Ignition section.

Check Carburetion

Before making a carburetion check, be sure the fuel tank has an ample supply of fresh, clean gasoline. Be sure that the shut-off valve is open and fuel flows freely through fuel line and filter before starting engine. Inspect and adjust the needle valve. Check to see that the choke closes completely. If engine will not start, remove and inspect the spark plug.

If plug is wet, look for –

1. Over choking
2. Excessively rich fuel mixture
3. Water in fuel
4. Inlet needle stuck open
5. Clogged air cleaner
6. Fouled spark plug

If plug is dry, look for -

1. Leaking carburetor mounting gaskets
2. Gummy or dirty carburetor, fuel filter, fuel lines, shut-off valve or fuel tank
3. Inlet needle stuck shut
4. Inoperative fuel pump (if so equipped)

A simple check to determine if the fuel is getting to the combustion chamber through the carburetor is to remove the spark plug and pour a small quantity of gasoline through the spark plug hole. Replace the plug. If the engine fires a few times and then stops, look for the same conditions as for a dry plug.

Equipment Affecting Engine Operation

What appears to be a problem with engine operation, such as hard starting, vibration, etc., may be the fault of the mower rather than the engine itself. Listed are the most common effects of equipment problems and what to look for as the most common cause.

Hard Starting, or Will Not Start

1. Check remote control assembly for proper adjustment.
2. Check ignition system.

Vibration

1. Cutter blade bent – Remove and replace.
2. Cutter blade out of balance – Remove and balance.
3. Crankshaft bent – Replace.
4. Worn blade coupling – Replace if coupling allows blade to shift, causing unbalance.
5. Mounting bolts loose – Tighten.
6. Mounting deck or plate cracked – Repair or replace.
7. Damaged belts or pulleys.

Power Loss

1. Grass cuttings build-up under deck.
2. No lubrication in transmission or gear box.
3. Dull blade.
4. Excessive drive belt tension may cause excess bearing wear or seizure.

Noise

1. BBC system problems (if so equipped).
2. No lubricant in transmission or gear box.
3. Worn drive belts.
4. Worn bearings.

Ignition

Contents

Check Ignition	14
Check For Spark Miss	14
Spark Plug	15
Spark Plug Maintenance	15
Remove Ignition Armature	15
Remove Flywheel	15
Inspect Flywheel Key, Keyways, Flywheel, and Crankshaft	16
Install Flywheel	16
Install Flywheel	16
Install Ignition Armature	16
Adjust Ignition Armature Air Gap	17
Specifications	17

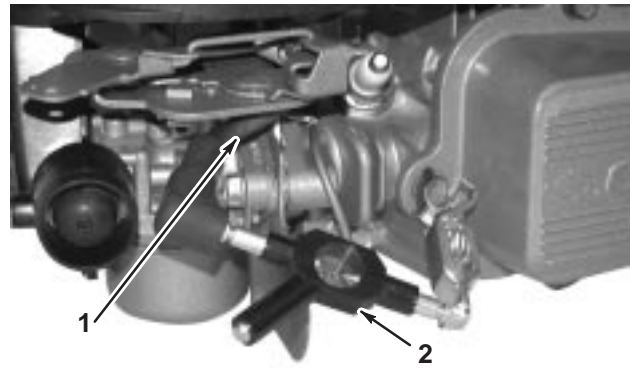

Fig. 9 – Checking for Spark

1. Spark plug wire
2. Spark tester, Briggs & Stratton Tool #19051 or #19368

Check For Spark Miss

1. Install Briggs & Stratton Tool #19051 or #19368, Spark Tester, in series with spark plug lead and spark plug, Fig. 10.

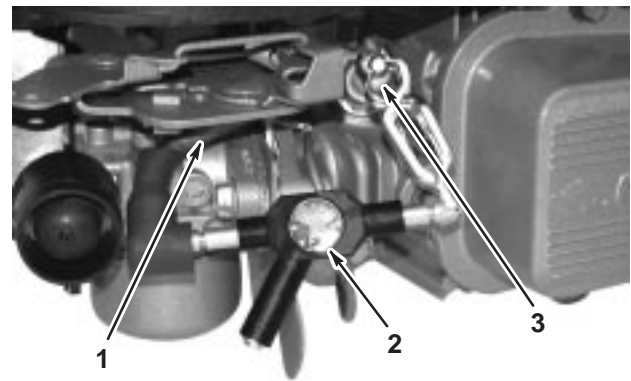

Fig. 10 – Running Check

1. Spark plug lead
2. Spark tester, Briggs & Stratton Tool #19051 or #19368
3. Spark plug

2. Start and run engine.
3. If spark jumps tester gap regularly, but miss continues, problem is spark plug, compression, or fuel system.

WARNING

TO PREVENT accidental starting, the spark plug wire must be removed from spark plug and grounded, failure to do so can cause personal injury.

WARNING

DO NOT remove spark plug when checking ignition. A fire or explosion may occur.

WARNING

FLYWHEEL KICKBACK can occur if the flywheel key is sheared and bodily injury may occur.

Check Ignition

1. Connect spark plug wire to Spark Tester, Fig. 9.
2. Operate starter and observe spark gap in tester. If spark jumps tester gap, ignition is good.

Note: Flywheel must rotate at 350 RPM, minimum.

Note: Spark will be observed.

Spark Plug

The recommended spark plug is:

Spark Plug Type	Brand
Resistor Long Plug	Champion RC12YC

Note: In some areas, local law requires the use of a resistor spark plug to suppress ignition signals. If an engine was originally equipped with a resistor spark plug, be sure to use the same type of spark plug for replacement.

Spark Plug Maintenance

Set gap at .020" (0.51mm), Fig. 11. If electrodes are burned away, or porcelain is cracked or fouled, replace with a new plug.

Note: Do not use abrasive cleaning machines.

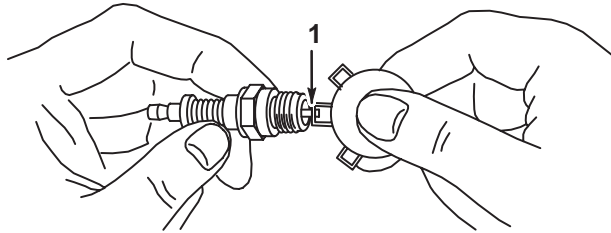

Fig. 11 – Adjusting Spark Plug Gap

1. .020" (0.51mm) wire gauge

Remove Ignition Armature

1. Remove blower housing.
2. Remove armature screws, disconnect stop wire, and lift off armature, Fig. 12.

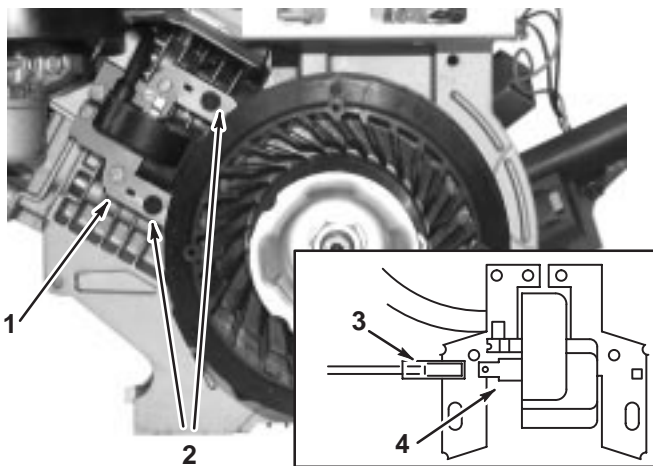

Fig. 12 – Removing Ignition Armature

1. Ignition armature
2. Screws
3. Stop switch wire
4. Terminal

Remove Flywheel

1. Remove blower housing.
2. Use flywheel holder to hold flywheel from turning, Fig. 13.



Fig. 13 – Removing Flywheel Nut

1. Flywheel holder Briggs & Stratton Tool #19372

3. Use socket and breaker bar to remove flywheel nut.

Note: Remove ignition armature before removing flywheel.

4. Thread flywheel nut onto crankshaft until top of nut is flush with crankshaft threads or slightly 1.5mm (1/16") above end of threads.
5. Attach flywheel puller.
6. Turn puller screws into flywheel puller holes until screws bottom.
7. Turn lower nuts down until flywheel puller body rests firmly on flywheel nut.
8. Then turn upper nuts down onto puller body. Turn both nuts equally until flywheel pops loose, Fig. 14.

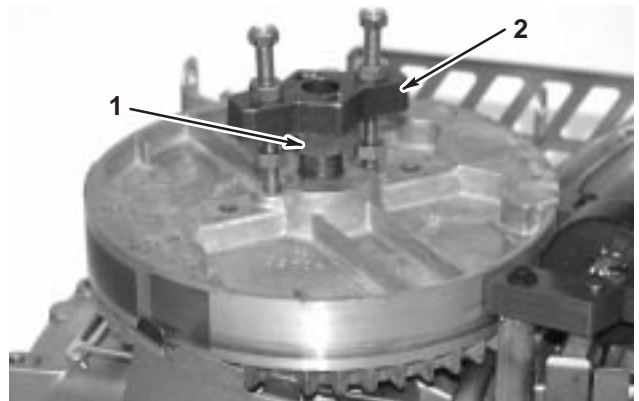

Fig. 14 – Removing Flywheel

1. Flywheel nut
2. Briggs & Stratton Tool #19069 flywheel puller

Inspect Flywheel Key, Keyways, Flywheel, and Crankshaft

Inspect flywheel key for partial or complete shearing. If sheared, replace, Fig. 15. Flywheel should be inspected for cracks, burrs on taper or keyway, and distortion of keyway. Check taper of crankshaft for burrs, rust, oil, or other damage. Check cooling fan or flywheel for broken fins. If parts are damaged, replace with new parts.

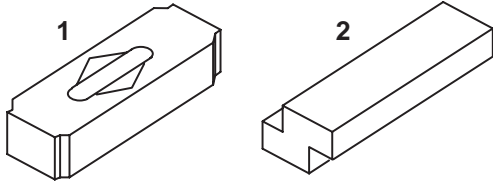

Fig. 15 – Inspect Flywheel Key

1. OK 2. Replace

Install Flywheel

Install Flywheel

1. Clean flywheel taper and crankshaft taper of all grease, oil and dirt.
2. Slide flywheel onto crankshaft and line up both keyways. Insert flywheel key into both keyways.

Note: DO NOT use a steel key under any circumstances.



WARNING



DO NOT use impact wrenches to install flywheel.

3. Install starter cup, cooling fan, and flywheel nut or screw.
4. Use flywheel holder to hold flywheel from turning, Fig. 16.
5. Install flywheel nut or screw.
6. Use socket and torque wrench to tighten flywheel nut or screw.
7. Torque as listed in Table No. 1, Page 17.

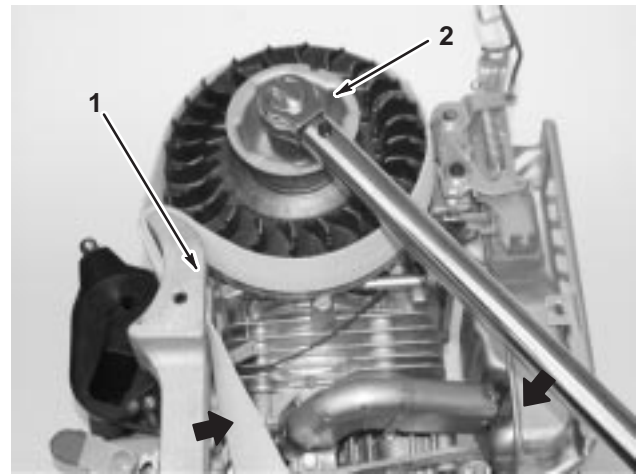

Fig. 16 – Torquing Flywheel

1. Briggs & Stratton Tool #19321, flywheel holder or Tool # 19372 flywheel strap wrench 2. Cup

Install Ignition Armature

1. Install stop switch wire on armature, Fig. 12, Page 15.
2. Turn flywheel so magnet is away from armature.
3. Install armature and mounting screws, Fig. 17.

Note: Mounting holes in armature are slotted.

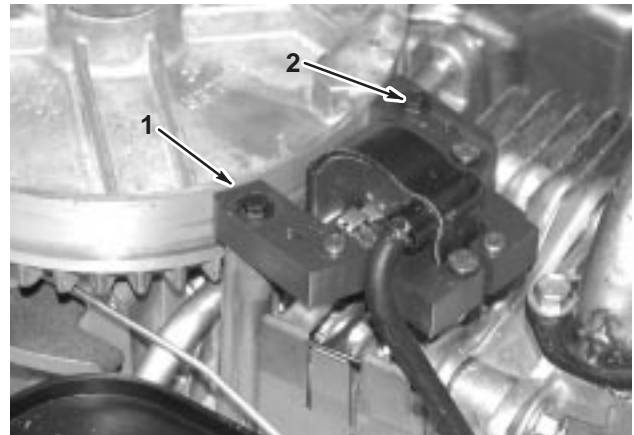

Fig. 17 – Installing Armature

1. Ignition armature 2. Tighten one screw

4. Push armature away from flywheel as far as possible and tighten one screw to hold armature in place.

Adjust Ignition Armature Air Gap

1. Rotate flywheel until magnet is under armature laminations.
2. Place thickness gauge, Table No. 1, Page 17, between magnet and armature laminations, Fig. 18.

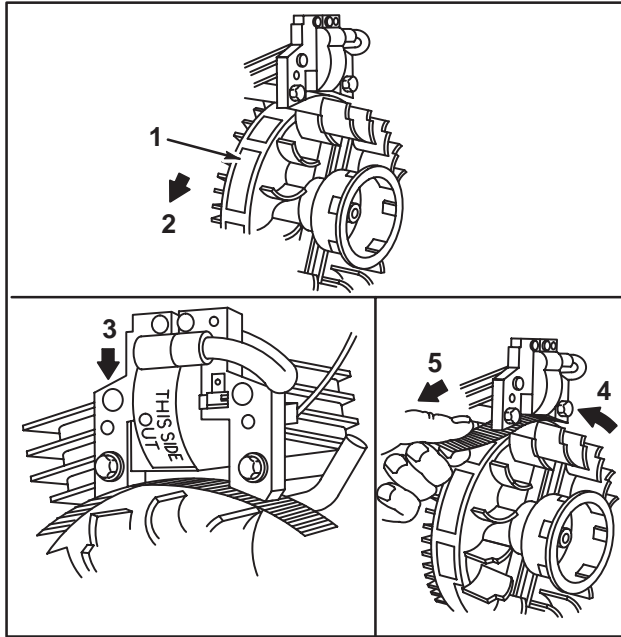

Fig. 18 – Adjusting Armature Air Gap

1. Magnet
2. Turn magnet away from armature
3. Armature down; gauge stock in place
4. Turn
5. Roll out gauge

3. See Table No. 1, Page 17 for armature air gap. Loosen mounting screw so magnet will pull armature down against thickness gauge.
4. Torque both mounting screws to 25 in. lbs. (3.0Nm) Rotate flywheel to remove thickness gauge.
5. Install outer blower housing and screws and torque screws to 85 in. lbs., (10.0Nm), Fig. 19.

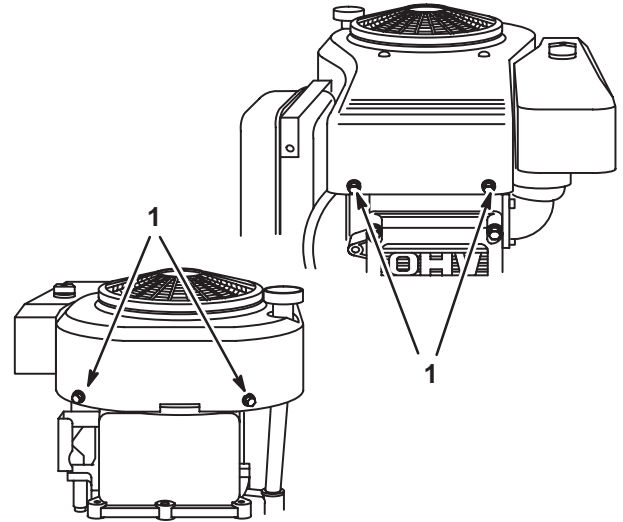

Fig. 19 – Installing Outer Blower Housing

1. Torque screws to 85 in. lbs.

Specifications

Table No. 1

Armature Air Gap	Flywheel Puller Briggs & Stratton Tool #	Flywheel Holder Briggs & Stratton Tool #	Flywheel Nut Torque
.006" – .012" (0.15 – 0.30mm)	19069	19372	60 ft. lbs. (81.0Nm)

Carburetion

Contents

Carburetor Identification	18
Service Carburetor Walbro LMS	18
Remove Air Cleaner	18
Remove Carburetor	19
Disassemble Carburetor	19
Carburetor Cleaning Recommendations	20
Assemble Carburetor	20
Install Welch Plug	20
Install Throttle Shaft	20
Install Inlet Needle Seat	20
Install Inlet Needle and Float	20
High Altitude Compensation	21
Install Carburetor	21
Install Air Cleaner	21

Carburetor Identification

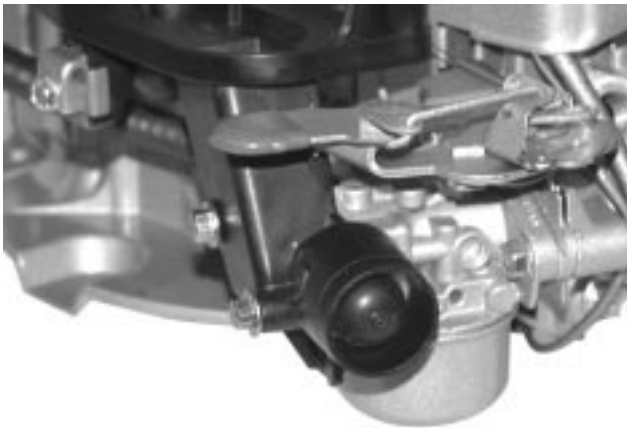

Fig. 20 – Primer Carburetor

Service Carburetor Walbro LMS

These carburetors have a fixed high speed main jet with non-adjustable idle mixture, Fig. 21.

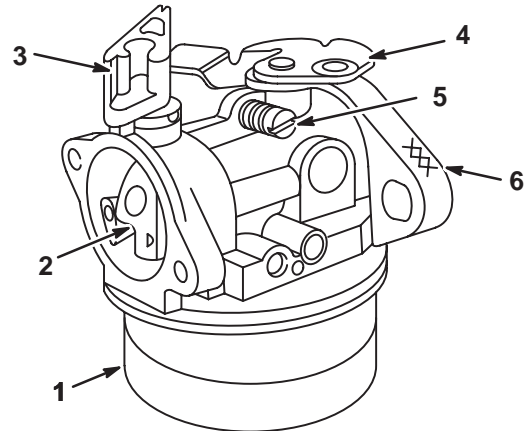

Fig. 21 – Fixed Main Jet Carburetor

- | | |
|----------------|---------------------|
| 1. Float bowl | 4. Throttle lever |
| 2. Choke plate | 5. Idle speed screw |
| 3. Choke lever | 6. I.D. number |

Remove Air Cleaner

1. Remove air cleaner screws and air cleaner cover. Remove air cleaner element, Fig. 22.
2. Then remove two (2) screws holding air cleaner/primer base on carburetor, Fig. 22.

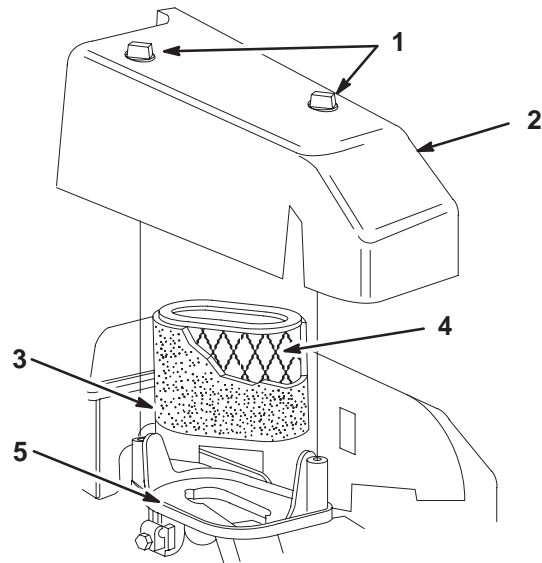

Fig. 22 – Removing Air Cleaner

- | | |
|----------------|--------------|
| 1. 2 screws | 4. Cartridge |
| 2. Cover | 5. Base |
| 3. Pre-cleaner | |

m-3664

WARNING

NEVER START or operate engine with air cleaner removed, fire can result.

CAUTION

TO PREVENT accidental starting when servicing engine or equipment, always remove spark plug wire from spark plug and prevent wire from contacting spark plug.

Remove Carburetor

1. Move fuel line clamp and disconnect fuel line from carburetor.

! **WARNING** !

CLOSE FUEL valve or plug fuel line to prevent fuel spillage. Do not use a screw to plug fuel line as this damages interior of hose.

2. Remove carburetor and rotate carburetor until governor link is free.
3. On current production engines, the control bracket is held on with three (3) screws, of which two (2) were removed to remove the carburetor, Fig. 23. On early production engines, only two (2) screws held both carburetor and control bracket. Reinstall both screws to retain control bracket until carburetor is reinstalled.

Note: Replace air cleaner gaskets and mounting gaskets whenever carburetor is removed for service.

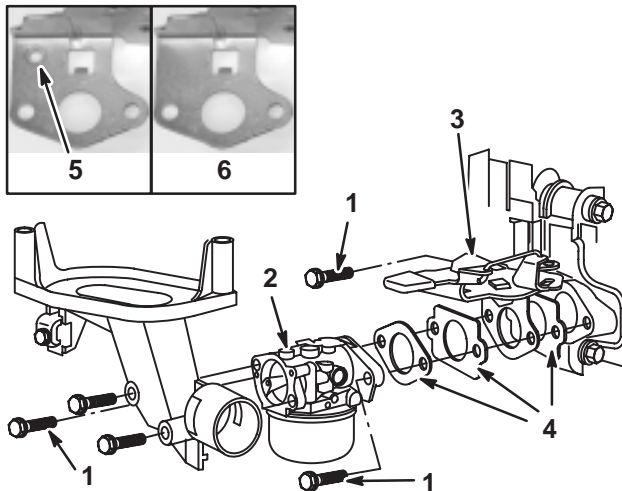

Fig. 23 – Removing Carburetor

- | | |
|-------------------------------|---------------------------------|
| 1. Mounting screw | 5. Current style, mounting hole |
| 2. Carburetor | 6. Early style |
| 3. Carburetor control bracket | |
| 4. Gasket | |

4. Remove two (2) carburetor mounting screws.

Disassemble Carburetor

1. Remove bowl nut (with fixed main jet) and fiber washer.
2. Remove float bowl and bowl gasket from carburetor.
3. Remove float hinge pin, float and inlet needle, Fig. 24.

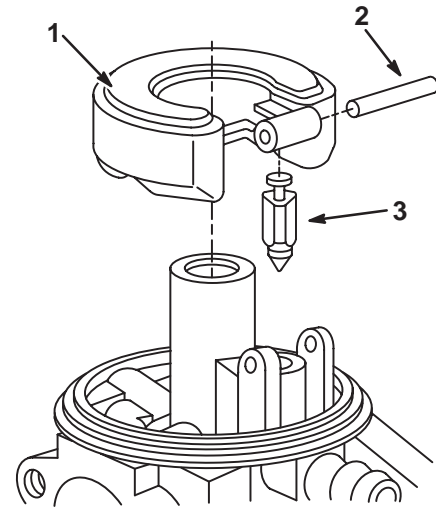

Fig. 24 – Removing Main Jet, Float Hinge Pin and Inlet Needle

- | | |
|--------------------|-----------------|
| 1. Float | 3. Inlet needle |
| 2. Float hinge pin | |

4. Remove idle speed screw with spring, when used.
5. Rotate throttle shaft to closed position and remove throttle plate screw.
6. Remove throttle plate and throttle shaft with foam seal.
7. Grasp choke plate and remove from choke shaft.
8. Remove choke shaft and felt or foam washer, when used.
9. With a modified 5/16 inch (3.9mm) pin punch, remove welch plug(s) from carburetor body, Fig. 25.

Note: A convenient way to remove inlet needle seat is with a #5 crochet hook.

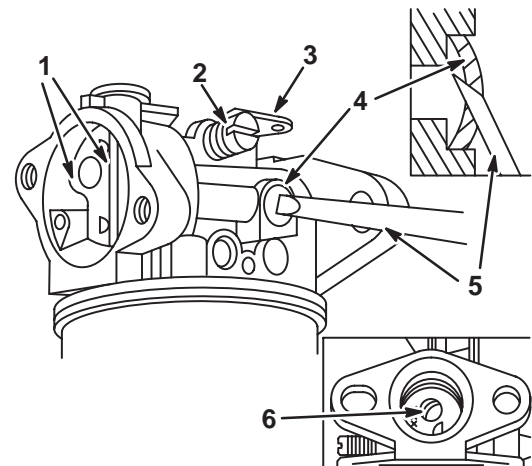

Fig. 25 – Removing Welch Plug

- | | |
|--------------------------|-------------------------|
| 1. Choke plate and shaft | 4. Welch plug |
| 2. Idle speed screw | 5. 5/32" punch |
| 3. Throttle shaft | 6. Throttle plate screw |

Carburetor Cleaning Recommendations

1. Disassemble carburetor.
2. Remove all old gaskets, seals and sealing material.
3. Use commercial carburetor cleaning solvents to clean carburetor parts and body.
4. When cleaning non-metallic parts (plastic, nylon, Minlon™, etc.), do not leave in commercial carburetor cleaner bath more than 15 minutes.

Note: Parts containing rubber, such as seals, “O” rings or pump diaphragms should never be placed in commercial carburetor cleaner bath.

5. Use only compressed air (blowing in both directions) to clean out all openings and passages.

Note: Do not use wires, drills or any other devices to clean out metering holes or passages.

Assemble Carburetor

Install Welch Plug

1. Install welch plug(s) with pin punch slightly smaller than outside diameter of plug, Fig. 26.

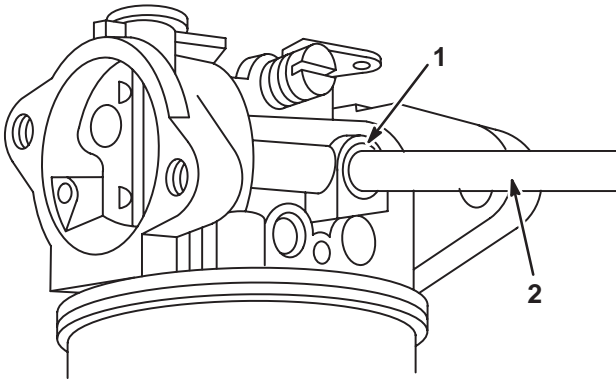

Fig. 26 – Installing Welch Plug

1. Welch plug
2. Pin punch

2. Press in until plug is flat. Do not cave in plug.
3. After plug is installed, seal outside edge of plug with fingernail polish or non-hardening sealant.

Install Throttle Shaft

1. Install throttle shaft and foam washer.
2. Turn shaft until flat is facing out.

3. Lay throttle plate on shaft with numbers facing out and install screw, Fig. 27. Use a new patchlock screw, or use Loctite to secure screw in place.

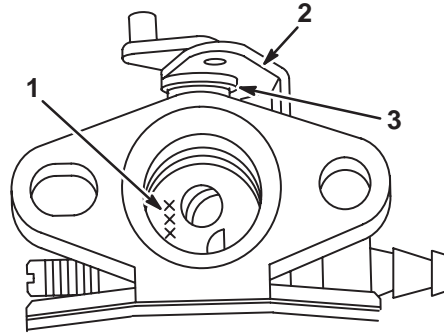

Fig. 27 – Installing Throttle Shaft

1. Numbers
2. Throttle shaft
3. Foam washer

Install Inlet Needle Seat

Install inlet needle seat with groove down using Briggs & Stratton Tool #19057, Bushing Driver, until seated, Fig. 28.

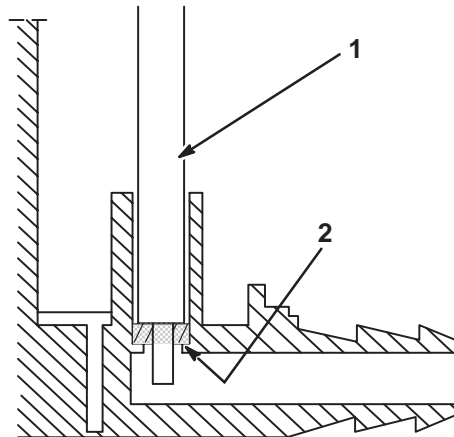

Fig. 28 – Installing Inlet Needle Seat

1. Bushing driver tool #19057
2. Groove

Install Inlet Needle and Float

1. Install inlet needle on float and install assembly on carburetor body.
2. Insert float hinge pin and center pin between float pin bosses. Float height is non-adjustable.
3. Install rubber gasket on carburetor and lay float bowl on body.

- Place fiber washer over main jet and install main jet. Torque nut to 50 in. lbs. (6.0Nm), Fig. 29.

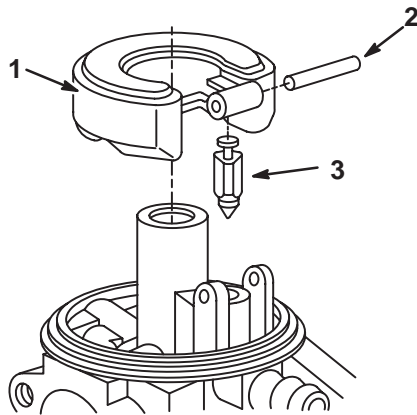

Fig. 29 – Installing Float, Hinge Pin and Inlet Needle

- | | |
|--------------|-----------------|
| 1. Float | 3. Inlet needle |
| 2. Hinge pin | |

High Altitude Compensation

Note: If engine is operated at high altitudes, performance may decrease. If poor performance is experienced refer to the proper Toro parts manual for replacement high altitude main jet.

Install Carburetor

- Hook governor link into grommet on throttle lever from the top, Fig. 30.

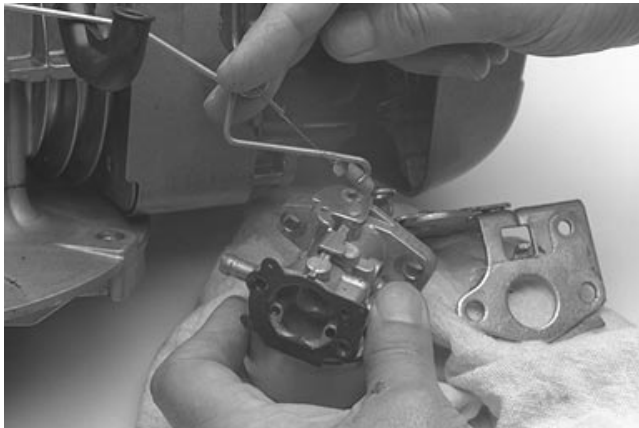

Fig. 30 – Install Carburetor

- Place new intake gasket on throttle side of carburetor, Fig. 31.
- Using carburetor mounting screws to align parts, place carburetor on control bracket, Fig. 31.
- Install carburetor assembly with two (2) mounting screws torquing screws to 80 in. lbs. (10.0Nm), Fig. 31.

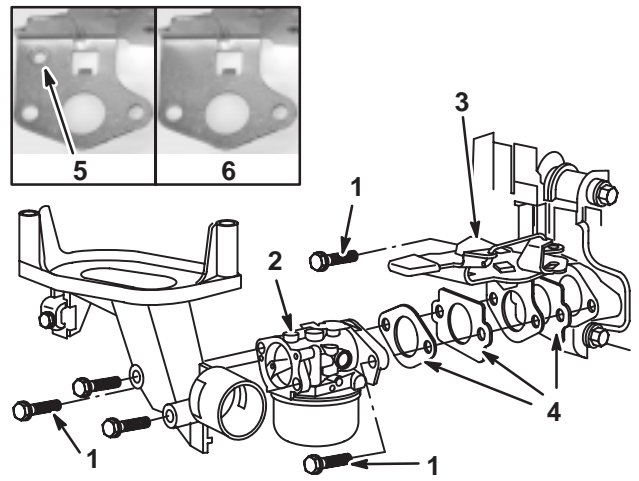

Fig. 31 – Installing Carburetor

- | | |
|-------------------------------|---------------------------------|
| 1. Mounting screw | 5. Current style, mounting hole |
| 2. Carburetor | 6. Early style |
| 3. Carburetor control bracket | |
| 4. Gasket | |

Install Air Cleaner

- Install breather tube on air cleaner primer base and position base with new gasket on carburetor mounting surface.
- Install air cleaner primer base with two (2) screws into carburetor.
- Torque two (2) carburetor mounting screws to 30 in. lbs. (3.0Nm), Fig. 32.

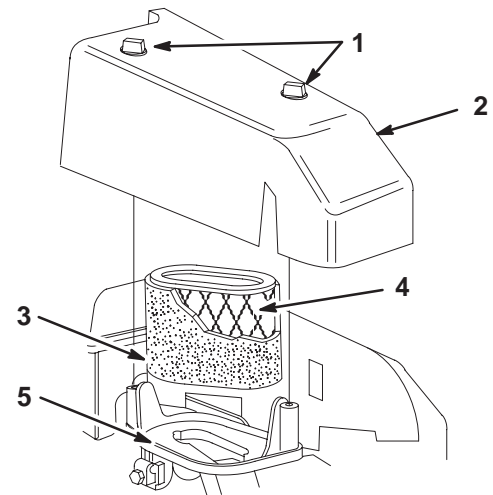

Fig. 32 – Installing Intake Elbow Assembly

- | | |
|----------------|--------------|
| 1. 2 screws | 4. Cartridge |
| 2. Cover | 5. Base |
| 3. Pre-cleaner | |
- Install air cleaner cartridge and pre-cleaner, Fig. 32.
 - Install air cleaner cover and two (2) screws, tighten screw farthest from spark plug first.

Governor Controls, Carburetor Linkage, and Flywheel Brake

Contents

Remote Governor Controls	22
Remote Control Wire Travel	22
Speed Regulation	22
Adjust Remote Controls	22
Flywheel Brake	22
Operation	22
Remove Flywheel Brake	23
Assemble Flywheel Brake	23
Brake Adjustment	24
Governor Adjustments	24
Governor and Carburetor Linkages	24

Remote Governor Controls

Remote Control Wire Travel

In order to make proper remote control adjustments, the travel of the remote control wire must be not less than 1-3/8" (35mm) with controls mounted in equipment, Fig. 33.

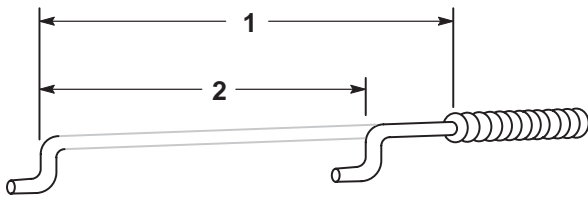

Fig. 33 – Control Wire Travel

1. 2-1/8" (54mm) minimum
2. 1-3/8" (35mm) minimum travel

Remote governor controls change engine speed by increasing or decreasing tension on governor spring to obtain desired engine speed. Remote controls will provide governor control at all positions.

Speed Regulation

When remote control is moved toward FAST position, governor control rotates and increases tension of governor spring on governor lever. Governor link moves throttle lever and valve on carburetor toward wide open position, Fig. 34.

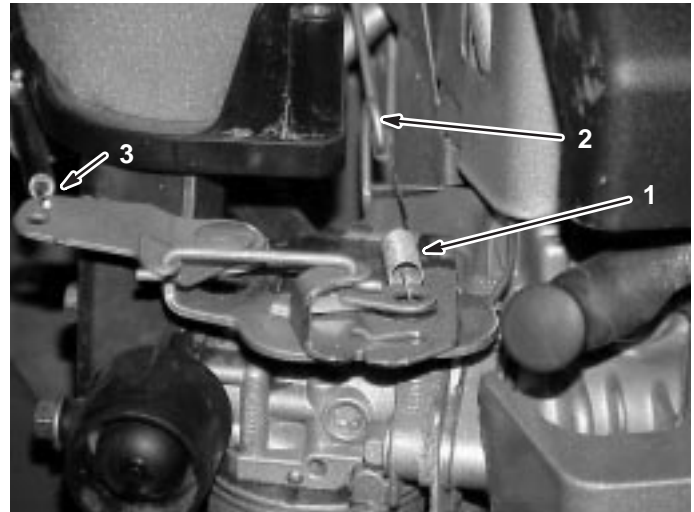
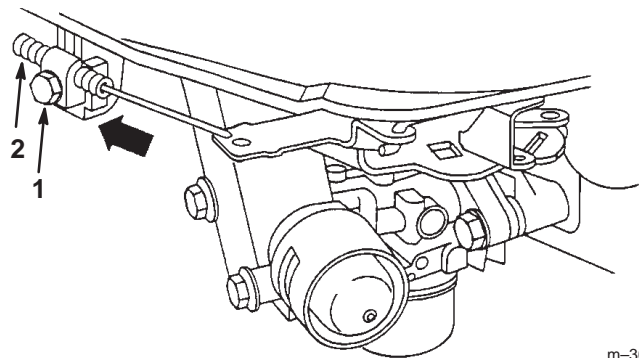

**Fig. 34 – Speed Regulation
(air cleaner removed for clarity)**

1. Governor spring
2. Governor link
3. Remote control cable

Adjust Remote Controls

1. Loosen casing clamp screw.
2. Move equipment throttle lever to fast position.
3. Move casing in direction of arrow (Fig. 35) until casing stops moving.



m-3638

Fig. 35 – Adjusting Remote Controls

1. Casing clamp screw
2. Casing

4. Tighten casing clamp screw.

Flywheel Brake

Operation

The flywheel brake is part of the safety control system required for this engine. The flywheel brake **MUST** stop the engine within three seconds, while running at **FAST** speed position, when the operator releases the equipment safety control.

Remove Flywheel Brake

1. Disconnect spark plug lead from spark plug.
2. Remove static guard and fuel tank, Fig. 36.

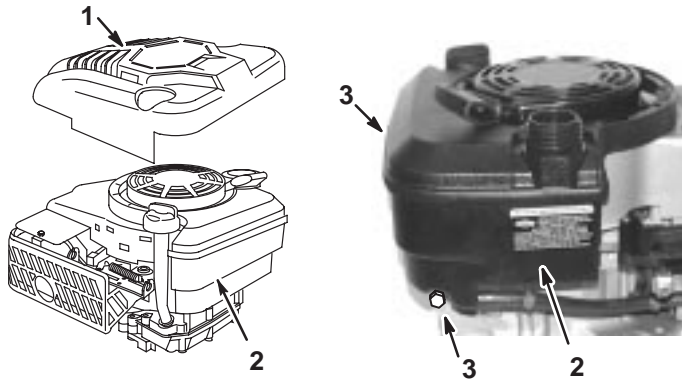

Fig. 36 – Removing Static Guard and Fuel Tank

1. Static guard
2. Fuel tank
3. Screw

3. Remove dipstick and oil fill tube, Fig. 37.
4. Remove blower housing and rewind starter, Fig. 37.

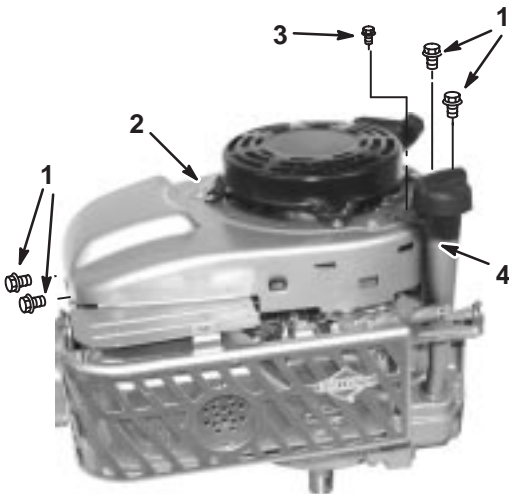

Fig. 37 – Removing Dipstick and Oil Fill Tube, Blower Housing and Rewind Starter

1. Screw
2. Blower housing and rewind starter
3. Dipstick screw
4. Dipstick and oil fill tube

5. Disconnect spring from brake anchor.
6. Disconnect stop switch wire from stop switch. If engine is equipped with electric starter, disconnect both wires from starter interlock switch.

7. Remove two screws from brake bracket and remove bracket, Fig. 38.

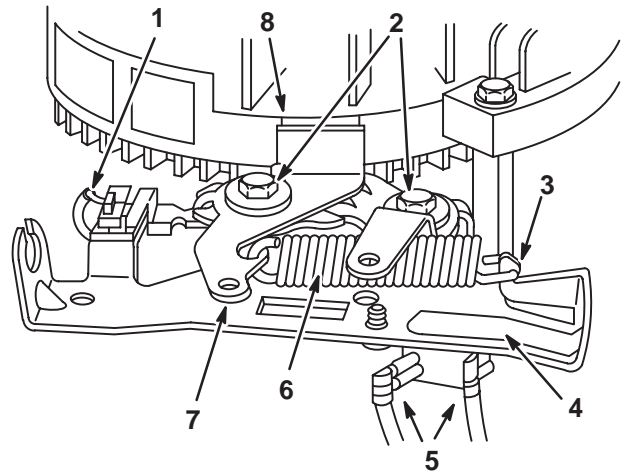

Fig. 38 – Removing Brake Bracket

1. Stop switch wire
2. Screw
3. Anchor
4. Brake bracket
5. Starter interlock switch wires
6. Brake spring
7. Brake lever
8. Brake pad

Inspect Flywheel Brake and Switches

1. Inspect brake lining on brake lever. Replace brake assembly if lining is less than .090" (2.28mm) thick.
2. Test stop switch as described in the section General Information, stop switch – remote control.
3. Test electric starter interlock switch as described in the section Electric Starter, Check Interlock Switch.

Assemble Flywheel Brake

1. Install brake assembly on crankcase and torque mounting screws to 40 in. lbs. (5.0Nm) Fig. 38.
2. Install stop switch wire and bend end of wire 90°. Install interlock switch wires on interlock switch, if used, Fig. 38.
3. Install blower housing as described on page 37, "Install Blower Housing and Rewind Starter."
4. Install dipstick tube and dipstick.
5. Install fuel tank and static guard.

Brake Adjustment



WARNING



TO PREVENT accidental starting, the spark plug wire must be removed from spark plug and grounded, after removing boot. Failure to do so can cause personal injury.

1. Using a torque wrench and socket to fit flywheel nut, turn flywheel clockwise with brake engaged. While turning at a steady rate, torque reading should be 30 in. lbs. (3.0Nm) or higher.
2. If reading is low, check thickness of brake pad. Replace brake lever and pad if pad thickness is less than .090" (2.28mm).
3. If brake pad thickness is acceptable, adjust control cable casing anchor to position pad closer to flywheel when handle control bail is in RUN position.
4. Replace brake assembly if correct adjustment cannot be made.

Governor Adjustments

To remove slack from the governor linkage:

1. Slightly loosen the governor nut, Fig. 39.

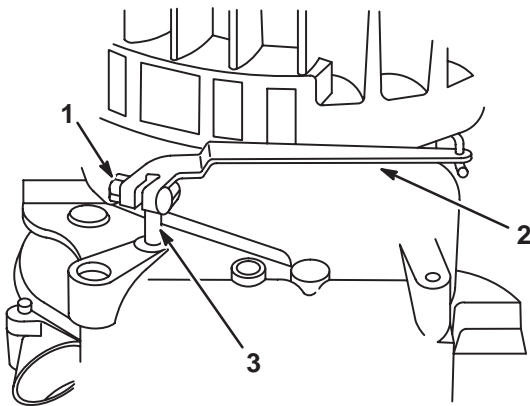

Fig. 39 – Adjusting Governor Linkage

1. Governor lever nut
2. Governor lever
3. Governor crank

2. Turn the governor crank to the right (clockwise) until it stops.
3. Rotate the governor lever to the right until it stops. Hold and tighten the governor lever nut.

To adjust top no load RPM, see page 26.

Refer to page 26 for specific procedures for governor adjustments.

Governor and Carburetor Linkages

Figures 40 and 41 show governor and carburetor linkages.

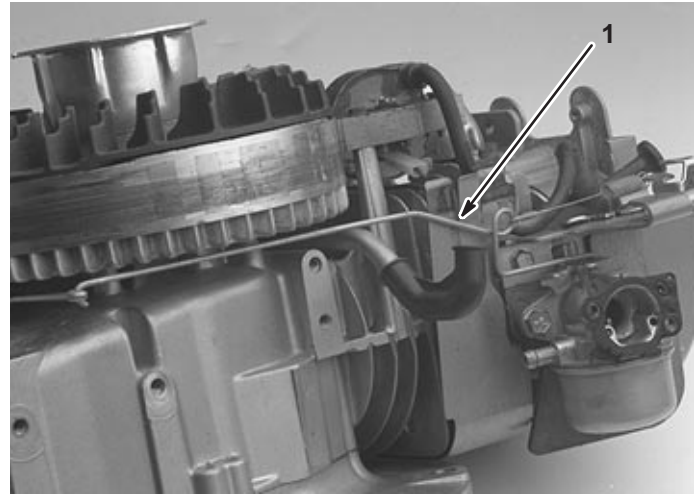
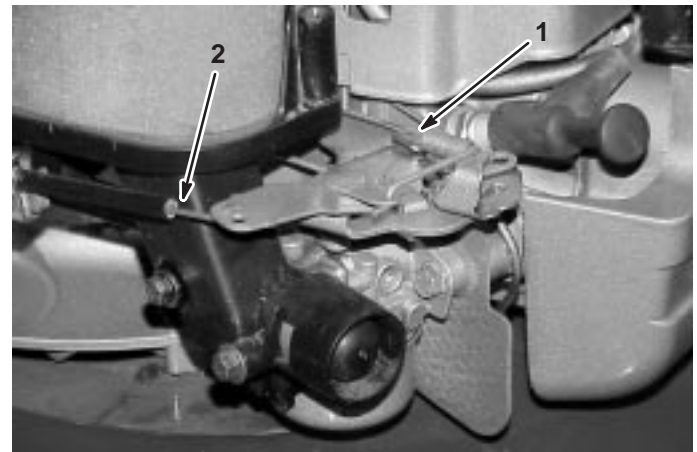

Fig. 40 – Linkages

1. Governor link



**Fig. 41 – Linkages
(air cleaner removed for clarity)**

1. Governor spring
2. Remote control cable

Governor

Contents

General Information	25
Governed RPM Limits	25
Mechanical Governor	25
Disassemble	25
Inspect Governor	26
Assemble Governor Crank	26
Install Crankcase Cover or Sump	26
Adjust Top No Load RPM	26
Seal Protectors	26

General Information

The governor spring tends to pull the throttle open. The force of the counterweights, which are operated by centrifugal force, tends to close the throttle. The engine speed at which these two forces balance is called the governed speed. The governed speed can be varied by changing governor spring tension or governor spring, Fig. 42.

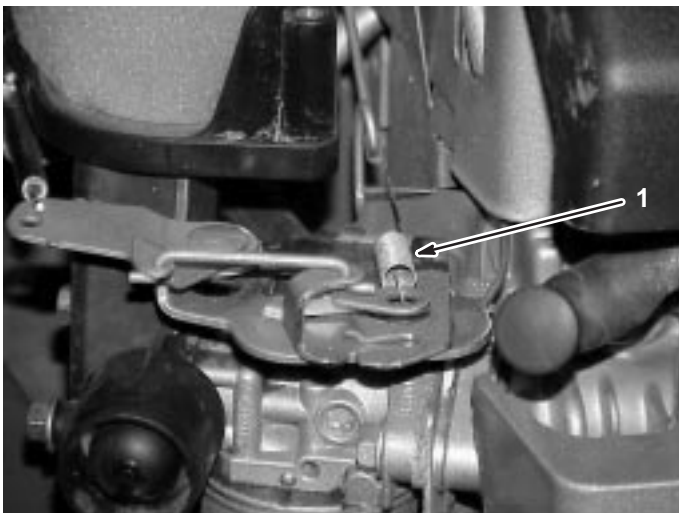

Fig. 42 – Governor Spring (blower housing removed)

1. Governor spring

Governed RPM Limits

To comply with specified top no-load speed limits, engines use either calibrated governor springs or an adjustable top no load speed. Calibrated springs or an adjustable top no load speed limit will allow no more than a desired top governed speed when the engine is operated on a rigid test stand. However, the design of the cutter blade, deck, etc., can affect engine speeds. Therefore, the top no load speed should be checked with a tachometer when the engine is operated on a

completely assembled machine. The RPM should be measured with the mower on a hard surface to eliminate cutting load on the blade.

If a governor spring must be replaced, consult the appropriate Toro Illustrated Parts List.

! **CAUTION** !

AFTER A new governor spring is installed, check engine top no load speed.

Run engine at half throttle to allow the engine to reach normal operating temperature before measuring speed with a tachometer.

Toro rotary mowers should be set to run at 3,000 RPM \pm 150, which will produce blade tip speeds of 19,000 feet per minute.

If a service replacement engine is used, check the top no load speed with the engine operating on a completely assembled mower. If necessary, change the governor spring or adjust the top no load speed limit device, so the engine will not exceed the recommended speed. See page 26 for adjustment procedure for mechanical governor.

Mechanical Governor

The mechanical governor used is illustrated in Fig. 43, and is part of the oil slinger assembly. The governor crank is mounted in the cylinder assembly.

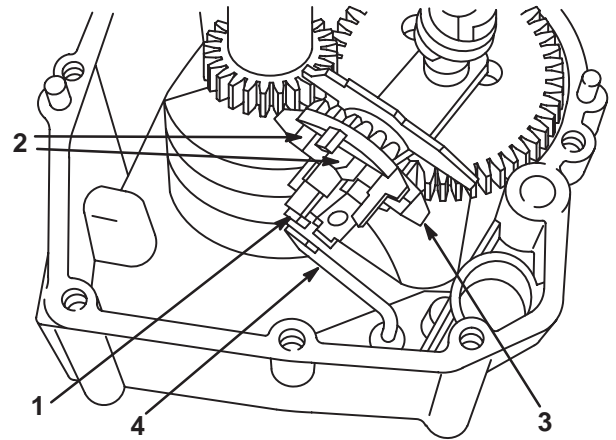

Fig. 43 – Governor

- | | |
|-------------------------|----------------------------------|
| 1. Governor cup | 3. Governor gear and oil slinger |
| 2. Governor weight pins | 4. Governor crank |

Disassemble

1. Before governor can be serviced, drain oil from engine and remove crankcase sump, page 53.
2. Loosen governor lever bolt and nut, Fig. 44.

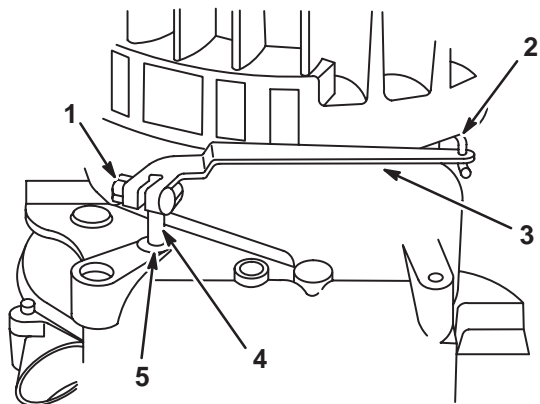

Fig. 44 – Removing Governor Lever

- | | |
|-----------------------|-------------------|
| 1. Governor lever nut | 4. Governor crank |
| 2. Governor link | 5. Push nut |
| 3. Governor lever | |

- Slide lever off governor crank and disconnect from governor link.
- Remove push nut and washer from governor crank, remove burrs from governor crank, and remove crank from inside cylinder, Fig. 44.

Inspect Governor

- Check governor gear and oil slinger assembly for worn governor weight pins, worn or damaged governor cup, and chipped or damaged teeth and paddles on oil slinger.
- Replace governor gear assembly if damaged.

Assemble Governor Crank

- Install governor crank from inside cylinder. Slide washer (when used) onto governor crank and install new push nut on governor crank.
- Slide governor lever onto governor crank and tighten bolt and nut on lever until governor crank turns with a slight resistance.
- Turn crank until crank end contacts governor cup on governor gear or oil slinger, Fig. 44.

Install Crankcase Cover or Sump

- Install new crankcase cover or sump gasket(s) of same thickness as originally removed on cylinder.
- Place Seal Protector, Briggs & Stratton Tool #19334 or #19356, BROWN, in seal of sump and slide sump down over crankshaft until sump seats.

Note: It may be necessary to rotate crankshaft and cam gear to get oil pump to engage oil pump drive slot in cam gear on vertical crankshaft engines.

- Install crankcase cover or sump screws and torque screws in order of numbers cast on outside surface of sump to 110 in. lbs. (12.0Nm), Fig. 45.

Note: Screw at position four was factory coated with sealant. If sealant is missing, coat with a non-hardening sealant such as Permatex® 2, or equivalent.

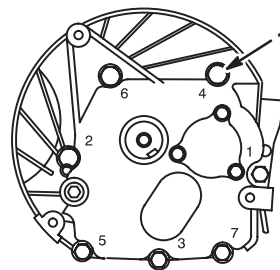

Fig. 45 – Torque Sequence

- Screw must have sealant

Adjust Top No Load RPM

- Start and run engine for approximately 5 minutes to allow it to reach operating temperature.
- Place throttle in fast position.
- Start engine and measure RPM using Tachometer. Adjust Top No Load RPM by bending governor tang, Fig. 46. Finger pressure will be sufficient to bend tang.

Note: RPM 3000 ± 150.

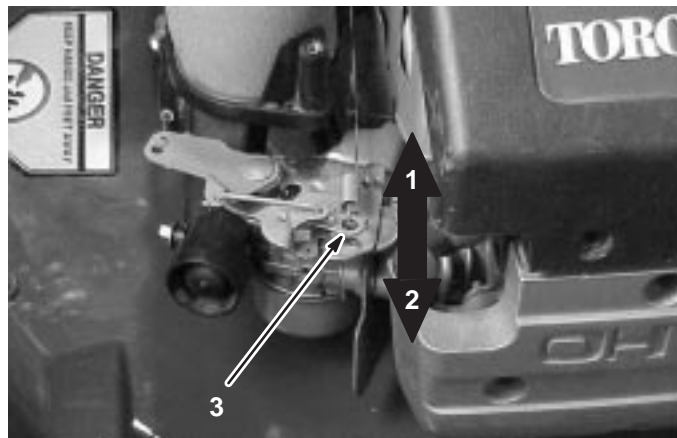

**Fig. 46 – Adjusting Top No Load RPM
(air cleaner cover removed for clarity)**

- | | |
|-------------|--------------|
| 1. Decrease | 3. Bend tang |
| 2. Increase | |

Seal Protectors

Briggs & Stratton Tool # 19334/5
Color Brown
Crankshaft Journal Size 1.062"
 (26.97mm)

Compression

Contents

Test Compression	27
Remove Cylinder Head	28
Prepare Cylinder Head for Removal	28
Remove Rocker Cover	28
Remove Cylinder Head	28
Remove Valves	29
Inspect Valve Guides	29
Valve Service	29
Reface Valves and Seats	29
Assemble Cylinder Head	29
Install Cylinder Head Plate and Rocker Arm Studs	29
Install Valves	30
Install Valve Springs and Retainers	30
Install Cylinder Head	30
Install Rocker Arms—Current Style	30
Install Rocker Arms—Early Style	31
Adjust Valve Clearance—Current Style	31
Adjust Valve Clearance—Early Style	31
Install Valve Cover	32
Specification Tables	32

Test Compression

1. Start and run engine for approximately 5 minutes to allow engine to reach operating temperature.

! **CAUTION** !

BEFORE PERFORMING following test, connect spark plug wire to engine ground.

Note: If engine is cold or cannot be started, air flow may be higher and gauge readings lower because compression components are not at normal operating temperatures.

2. Remove spark plug from engine. Then remove air cleaner and disconnect crankcase breather tube from air cleaner base (if equipped).
3. Rotate crankshaft *in direction of operation* until piston is at top dead center of **compression** stroke.
4. Assemble Briggs & Stratton Tool #19314, Clamping Tool, on crankshaft. Torque screws to 150 in. lbs. (17.0Nm).
5. Insert drive end of a 1/2" drive breaker bar into square hole in clamp, Fig. 47.
6. Pull regulator lock nut out and turn adjustment knob counterclockwise as far as it will go, Fig. 48.

Note: The crankshaft must be held with the piston at top dead center to eliminate any chance of rotation.

! **CAUTION** !

INJURY MAY occur if the crankshaft is not positively locked from rotating, and the engine is not securely fastened to a stand or the mower. The air pressure can create a rotational force of up to 60 ft. lbs. (81.0Nm) if the crankshaft is not locked with the piston at top dead center.

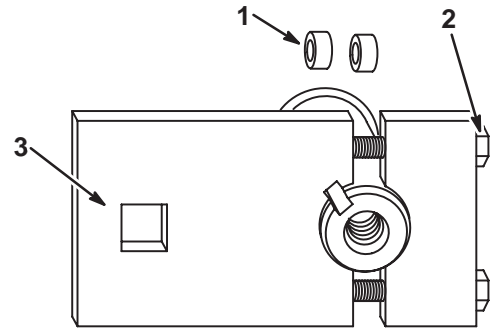

Fig. 47 – Installing Clamping Tool

1. 1" diameter crankshafts; remove spacers
2. Torque to 150 in. lbs. (17.0Nm)
3. 1/2" square hole

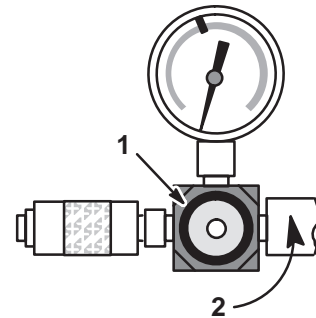

Fig. 48 – Pre-Setting Regulator

1. Regulator lock nut and adjustment knob
2. Turn counterclockwise
7. Connect tester to the shop air source (minimum air pressure of 70 psi. (49.2KPA).
8. Install outlet hose into spark plug hole of cylinder being tested. Be sure O-Ring is seated to prevent air leak at spark plug hole. Connect other end to tester.
9. With breaker bar held securely, slowly turn regulator adjustment knob clockwise until tester's inlet gauge needle is on the set point. Push in regulator lock nut. Note position of outlet gauge needle, Fig. 49.

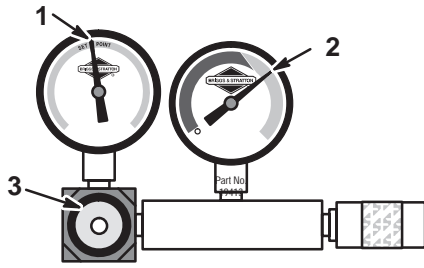

Fig. 49 – Setting Tester

1. Inlet gauge set point
2. Outlet gauge needle
3. Regulator adjustment knob

Note: Any air leaks at connections or fittings of tester will affect the accuracy of test.

10. Listen for air leaking from cylinder head gasket, carburetor, exhaust system and either crankcase breather or oil fill dipstick tube.

Note: If a high flow of air is leaking from exhaust and carburetor, make sure that piston is at TDC on compression stroke.

- Air flowing between cylinder and cylinder head indicates that cylinder head gasket is leaking.
- Air flowing from carburetor indicates air is leaking past intake valve and seat.
- Air flowing from exhaust system indicates air is leaking past exhaust valve and seat.
- Air flowing from crankcase breather tube or oil fill dipstick tube indicates air is leaking past piston rings.

11. When test is complete, push regulator lock nut in and turn regulator lock nut counterclockwise as far as it will go to release pressure in combustion chamber.

12. Disconnect outlet hose from tester before removing from spark plug hole.

Result	
Reading is Green. A small amount of air is leaking from head gasket.	Replace head gasket, then re-test.
Reading is Green Minimum air leakage.	Look for other problems that are not compression related.
Reading is Green/Red or Red, and all the air is leaking from one component.	Look for a possible problem with that component.
Reading is Red, and air is leaking from several components.	Check that piston is at TDC, on compression stroke. If reading does not change, look for problems beginning with component that appeared to leak the most air. Re-test after repair.

Remove Cylinder Head

Prepare Cylinder Head for Removal

Before cylinder head can be removed external parts such as air cleaner cover, fuel tank, oil fill tube and dipstick, blower housing with rewind starter, muffler guard and muffler, air cleaner, carburetor, carburetor control bracket assembly and carburetor adapter or intake manifold must be removed.

Remove Rocker Cover

1. Remove four screws from rocker cover.
2. Remove rocker cover and gasket(s), Fig. 50.

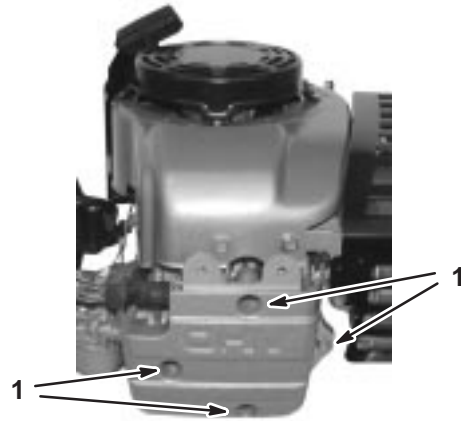

Fig. 50 – Removing Rocker Cover

1. Screw

Remove Cylinder Head

Remove cylinder head screws, cylinder head, push rods and cylinder head gasket, Fig. 51.

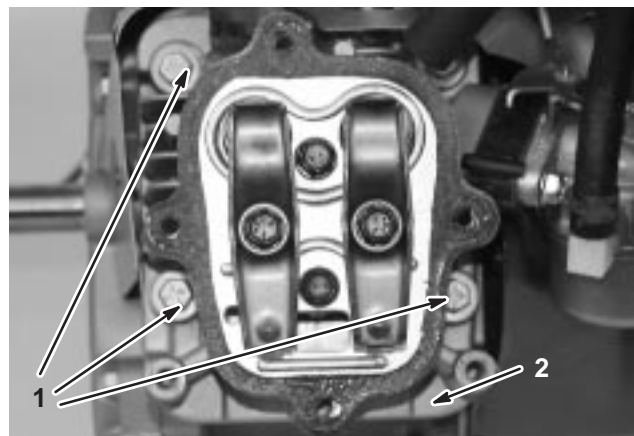

Fig. 51 – Removing Cylinder Head

1. Cylinder head screws
2. Cylinder head

Remove Valves

1. Place cylinder head on work surface.
2. Remove valve cap from valve stems, Fig. 52.

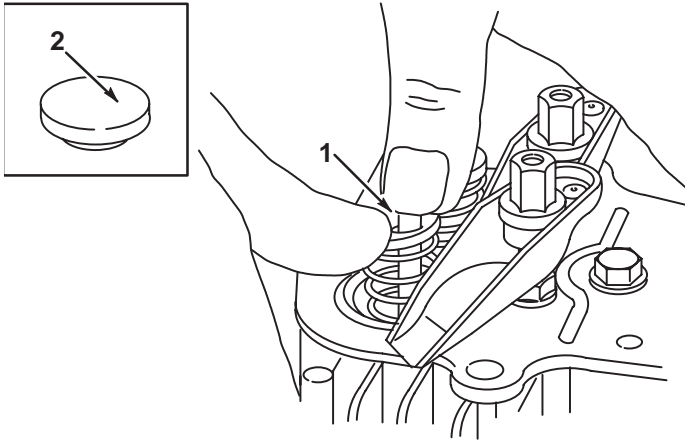

Fig. 52 – Removing Valves

1. Valve spring retainer
2. Valve cap

3. With thumbs, press down on valve spring retainer and spring to compress until large end of slot in retainer can line up with end of valve stem, Fig. 52.
4. Release pressure on retainer and spring.
5. Remove retainer, spring, and intake valve seal, if removing intake valve, Fig. 52.

Inspect Valve Guides

1. Measure intake and exhaust valve guides using Briggs & Stratton Tool #19122.
2. If flat end of gauge can enter guide for 1/4" (6.35mm) or more, cylinder head must be replaced.
3. If plug gauge is not available, refer to Table No. 1, Page 32 for reject size.

Valve Service

Reface Valves and Seats

Although valve faces can be resurfaced on a commercially available valve grinding tool, we do not recommend this practice as a high quality repair procedure. Valve replacement is recommended for damaged or worn valves. Valve seats are cut using Briggs & Stratton Tool #19237 or #19343, Neway Valve Seat Cutter Kit, to 45° on exhaust and some intake seats. Other intake seats are cut to 30°. Valve and seat are lapped in using Briggs & Stratton Tool #19258, Valve Lapping Tool, and Briggs & Stratton Part #94150, Valve Lapping Compound, to assure a good seal between the valve face and the seat.

1. Thoroughly clean lapping compound from valve seat and valve face.
2. Valve seat width should be as shown in Fig. 53.

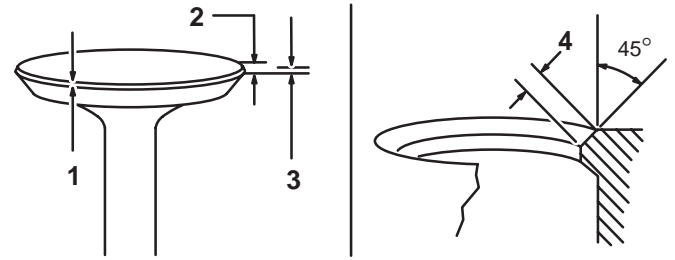

Fig. 53 – Valve and Seat Dimensions

1. Margin
2. 1/32" (.79mm) fit for use
3. 1/64" (.38mm) discard
4. Valve seat width minimum 3/64–1/16" (1.17–1.57mm)

3. If seat is wider, a narrowing cutter should be used. If valve face is badly burned, the burned valve should be replaced.
4. Replace valve if margin is 1/64 inch (.39mm) or less or damaged, Fig. 53.

If seats are burned or damaged, replace cylinder head.

Assemble Cylinder Head

Install Cylinder Head Plate and Rocker Arm Studs

1. Place new cylinder plate gasket and cylinder head plate on cylinder head.
2. Install and torque two (2) cylinder plate screws to 80 in. lbs. (9.0Nm), Fig. 54.

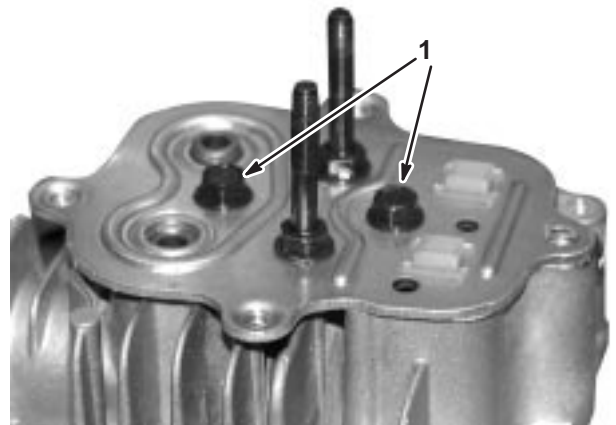

Fig. 54 – Installing Cylinder Head Plate

1. Screw: torque to 80 in. lbs. (9.0Nm)

Install Valves

1. Valve stems and guides must be free of foreign material and burrs or valve sticking will occur and valve stem seals will be damaged.
2. Lightly coat valve stems with Briggs & Stratton Part #93963, Valve Guide Lubricant, and install in valve guides.
3. Oil inside diameter of valve stem seal with engine oil and install on intake valve stem.
4. Slide seal down against head plate or cylinder head.

Note: Be sure Briggs & Stratton Part #93963, Valve Guide Lubricant, is not on valve face, valve seat, or exposed end of valve stem.

Install Valve Springs and Retainers

1. Place a shop rag or wood blocks on work surface to support valves. Place cylinder head on rag or blocks and install valve spring over valve stem. Place spring and retainer on valve stems, Fig. 55.



Fig. 55 – Valve Spring and Retainer

2. Place retainer on spring and with thumbs on retainer press on retainer to compress spring.
3. Compress spring until valve stem extends through large end of retainer slot. Continue to press until small end of slot can slide into groove on valve stem. Be sure retainer is fully engaged in valve stem groove, Fig. 56.

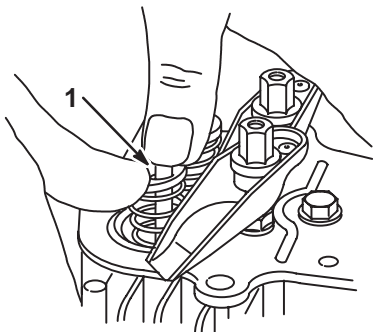

Fig. 56 – Installing Valve Retainers

1. Valve retainer

Install Cylinder Head

Note: Do not use sealer of any kind on gaskets.

1. Coat threads of cylinder head screws with Briggs & Stratton Part #93963, Valve Guide Lubricant.
2. Place new cylinder head gasket on cylinder headpins and then install cylinder head and cylinder head screws.
3. Torque screws as listed in Table No. 3, Page 32 in sequence that cylinder head screws are numbered on cylinder head, or as shown in Fig. 57.

It is recommended that cylinder heads be torqued in three (3) steps to a final torque of 220 in. lbs. (24.9Nm):

First step 75 in. lbs. (9.0Nm)

Second step 150 in. lbs. (17.0Nm)

Final step 220 in. lbs. (25.0Nm).

Torque screws evenly per number sequence in Fig. 57.

Note: Do not torque one screw down completely before the others, as it may cause a warped cylinder head.

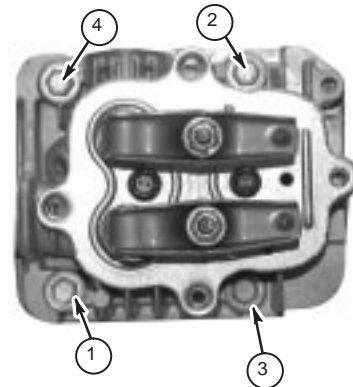

Fig. 57 – Torque Pattern, Cylinder Heads

Install Rocker Arms—Current Style

1. Install and torque two (2) rocker arm studs to 130 in. lbs. (15.0Nm), Fig. 58.

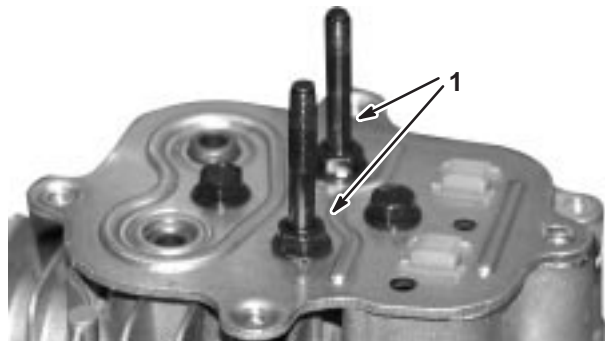

Fig. 58 – Installing Rocker Arm Studs

1. Rocker arm stud: torque to 130 in. lbs. (15.0Nm)

2. Install push rods through push rod guide making sure push rods are in valve tappets, Fig. 59.

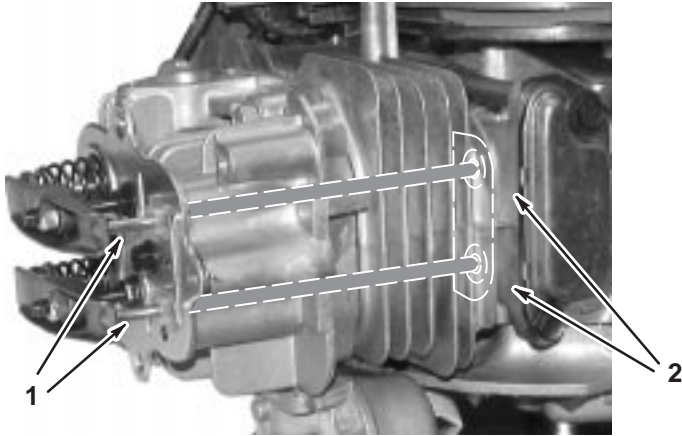

Fig. 59 – Installing Push Rods

1. Push rod
2. Valve tappet

3. Install caps on valve spring.
4. Place rocker arm and rocker ball on rocker arm stud.
5. Install rocker arm lock nut on stud and turn down until there is zero clearance between valve cap and rocker arm, Fig. 60.
6. Rotate crankshaft at least two (2) revolutions to be sure push rods operate rocker arms.

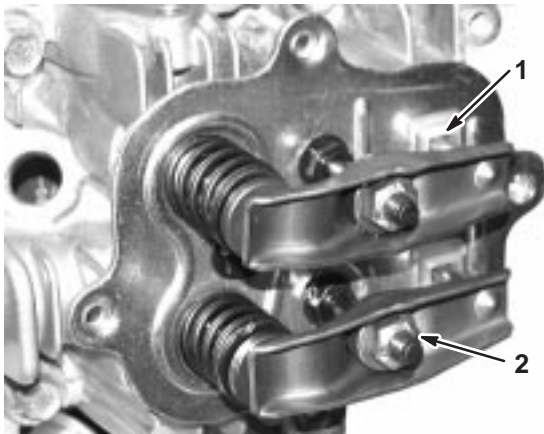

Fig. 60 – Installing Rocker Arms

1. Push rod guide
2. Lock nut

Install Rocker Arms—Early Style

1. Install push rods through push rod guide making sure push rods are in valve tappets, Fig. 59.
2. Place rocker arm ball on rocker arm screw and insert through rocker arm.
3. Install jam nut of end of rocker arm screw and run nut up on threads half way.

4. Install screw assembly from Step 3 and turn screw in until there is zero clearance between valve cap and rocker arm.
5. Rotate crankshaft at least two (2) revolutions to be sure push rods operate rocker arms.

Adjust Valve Clearance—Current Style

Note: Check valve clearances while engine is cold.

1. Turn crankshaft until piston is at Top Dead Center (both valves closed) on compression stroke.
2. Insert a narrow screwdriver or small rod into spark plug hole against piston. Screwdriver or rod is used to gauge piston movement.
3. Turn crankshaft clockwise (flywheel end), while watching screwdriver or rod, past Top Dead Center until piston is 1/4" (6mm) down.
4. Using feeler gauges, check valve clearance. Clearance should be as listed in Table No. 4, Page 32.
5. If not, adjust jam nut until correct clearance is obtained, Fig. 61.

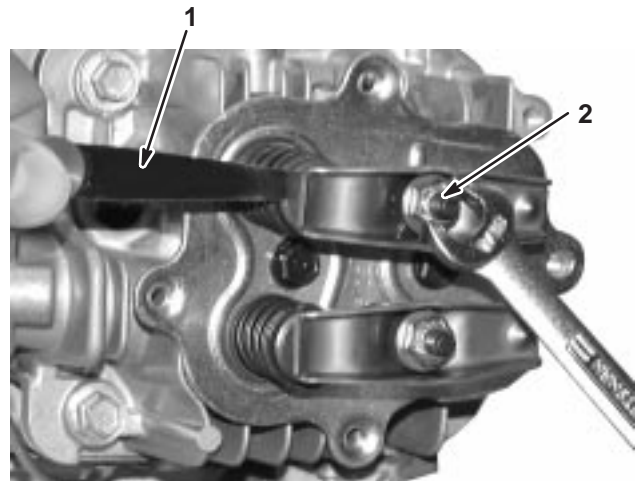

Fig. 61 – Adjust Rocker Arm Clearance, Current Style

1. Feeler gauge
2. Jam nut

Adjust Valve Clearance—Early Style

Note: Check valve clearances while engine is cold.

1. Turn crankshaft until piston is at Top Dead Center (both valves closed) on compression stroke.
2. Insert a narrow screwdriver or small rod into spark plug hole against piston. Screwdriver or rod is used to gauge piston movement.
3. Turn crankshaft clockwise (flywheel end), while watching screwdriver or rod, past Top Dead Center until piston is 1/4" (6mm) down.

- Loosen jam nut, Fig. 62.

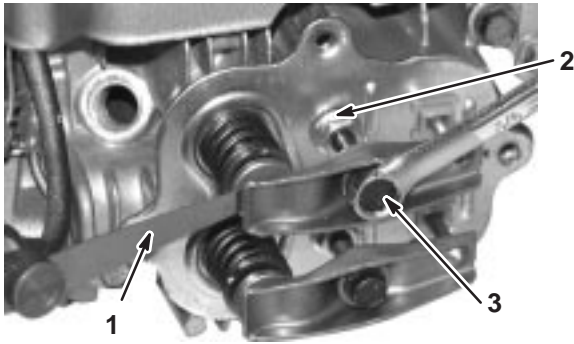

Fig. 62 – Adjust Rocker Arm Clearance, Early Style

- Feeler gauge
- Jam nut
- Rocker arm screw

- Using feeler gauges, check valve clearance. Clearance should be as listed in Table No. 4, Page 32.
- If not, adjust by turning rocker arm screw until correct clearance is obtained, Fig. 63.

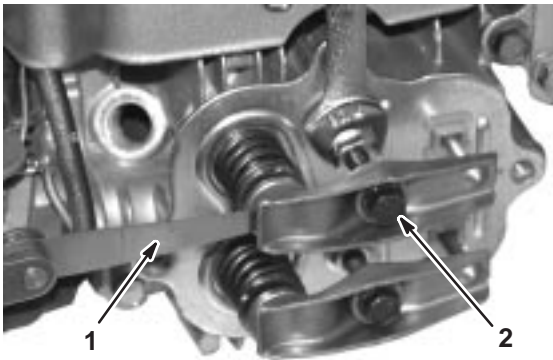

Fig. 63 – Adjusting Valve Clearance

- Feeler gauge
- Rocker arm screw

- While holding screw, torque jam nut to 85 in. lbs. (10.0Nm) and recheck clearance, Fig. 64. Recheck valve clearances and readjust, if required.

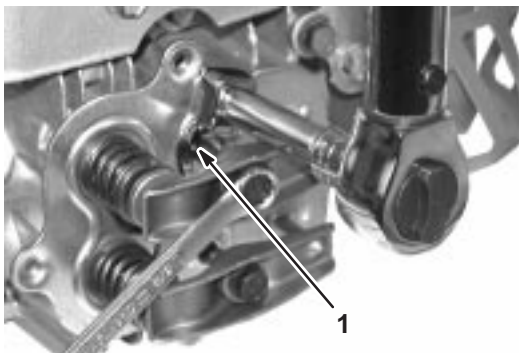

Fig. 64 – Locking Jam Nut

- Torque jam nut 85 in. lbs. (10Nm)

Install Valve Cover

- Install valve cover with new gasket. Install four screws, and tighten screws to torque listed in Table No. 5, Page 32, in sequence shown in Fig. 65.
- Install carburetor, exhaust manifold, air guides, shields and other parts removed from cylinder head.

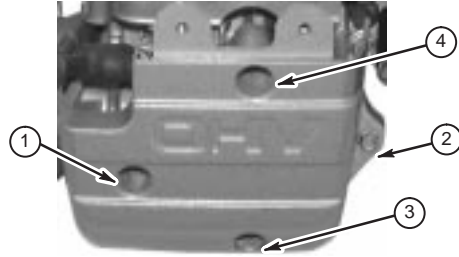

Fig. 65 – Valve Cover Torque Sequence

Specification Tables

Table No. 1

Valve Guide Rejest Dimensions Intake and Exhaust Gauge or Dimension
Briggs & Stratton Tool #19122 .260" (6.60mm)

Table No. 2

Rocker Arm Stud (Current Style) Torque In. Lb. (Nm)
100 (11.0)

Table No. 3

Cylinder Head Screw Torque In. Lb. (Nm)
210 (24.0)

Table No. 4

Valve Clearances	
Intake	Exhaust
.004-.008 (.10-.20mm)	.004-.008 (.10-.20mm)

Table No. 5

Valve Cover Torques In. Lb. (Nm)
85 (10.0)

Rewind Starter

Contents

General Information	33
Remove Blower Housing and Starter	33
Disassemble Rewind Starter	34
Remove Rope	34
Inspect Rope	34
Remove Pulley And Spring	35
Inspect Spring, Starter Housing and Pulley	35
Assemble Rewind Starter	36
Install Pulley and Spring	36
Install Pawls and Retainer Assembly	36
Wind Spring and Install Rope	36
Install Rewind Starter on Blower Housing	37
Install Blower Housing and Rewind Starter	37
Install Fuel Tank	37

General Information

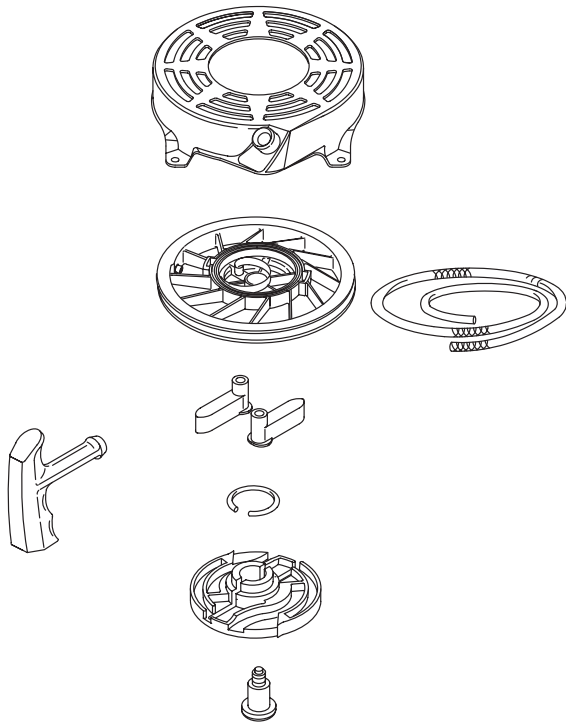
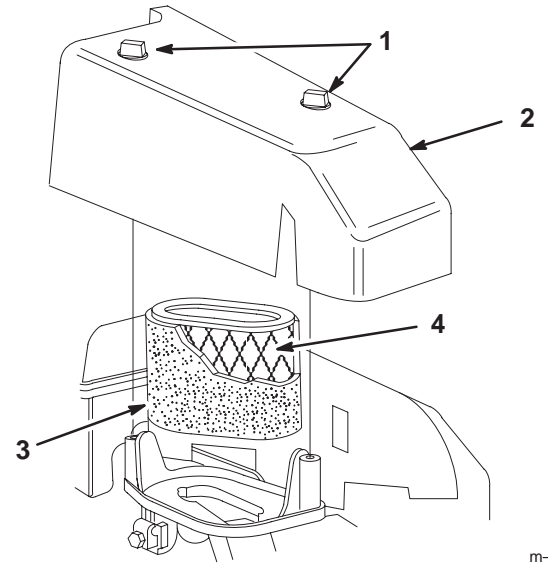

Fig. 66 – Rewind Starter, Exploded View

Remove Blower Housing and Starter

1. Remove cover screw and air cleaner cover, Fig. 67.



m-3664

Fig. 67 – Removing Air Cleaner Cover

- | | |
|----------|---------------------|
| 1. Knob | 3. Foam pre-cleaner |
| 2. Cover | 4. Paper cartridge |

2. Remove four (4) screws from rewind cover, Fig. 68. Remove cover.

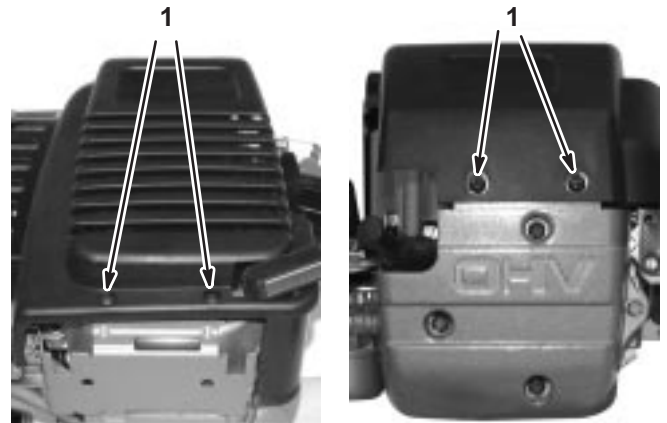

Fig. 68 – Removing Blower Housing Cover

1. Screw

3. Disconnect fuel line at carburetor and clamp fuel line. Remove three (3) screws holding fuel tank to blower housing and screw and spacer holding tank to cylinder, Fig. 69.

Note: Some models have fuel tanks that are held on the engine with a fuel tank mounting bracket. One screw holds tank to bottom of fuel tank bracket. The other screw holds tank to side of cylinder with a screw, rubber washer and plastic spacer. Slide fuel tank up off fuel tank bracket.

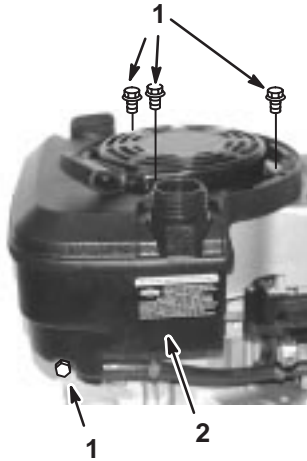

Fig 69 – Removing Fuel Tank

1. Screw
2. Fuel tank

4. Remove screw holding oil fill tube to blower housing and remove tube, Fig. 70.

Note: Some engines have a fuel tank bracket mounted on the rear of the engine that must be removed before the blower housing can be removed. 21" commercial mower engines use a four (4) quart fuel tank.



Fig. 70 – Removing Oil Fill Tube

1. Screws (2)
2. Blower housing and rewind starter
3. Dipstick and oil fill tube

5. Remove four (4) screws, two (2) from front and two (2) from rear of blower housing, Fig. 71.

Note: Rewind starters used on these engines are riveted to the blower housing. Replacement starters are supplied with screws and nuts to replace the rivets for mounting starter.

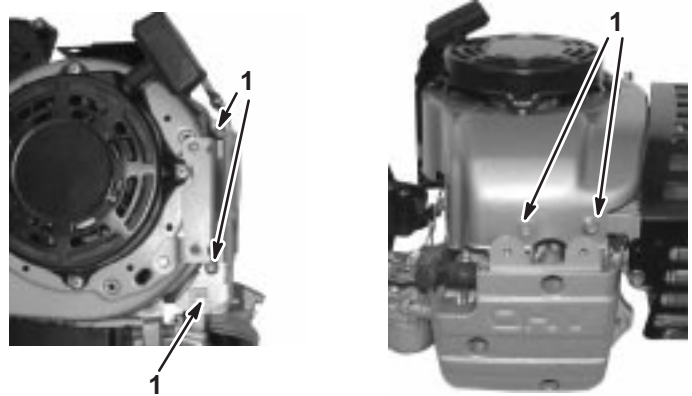

Fig. 71 – Removing Blower Housing

1. Screw

Disassemble Rewind Starter

Remove Rope

1. Pull starter rope out as far as it will go.
2. While holding pulley and starter housing, pull pulley end of rope out and untie knot at end of rope.
3. Remove rope and handle from starter.
4. Slowly release pulley to release spring tension.

Inspect Rope

1. Inspect rope for fraying or broken strands.
2. Replace if frayed or broken strands are found.
3. If re-using old rope, burn each end of rope with an open flame.
4. Wipe with waste cloth, using caution, while it is still hot, to prevent swelling and unravelling.

Note: When installing a new rope, check parts list to be sure correct diameter and rope length is used. The service replacement rope is cut to length as required: See Table No. 1.

Table No. 1

Rewind Starter Rope Specifications

Rope Size	Length	
	Inches	Meters
#5	88-5/8	2.25

Remove Pulley And Spring

1. Remove shoulder screw and retainer, Fig. 72.

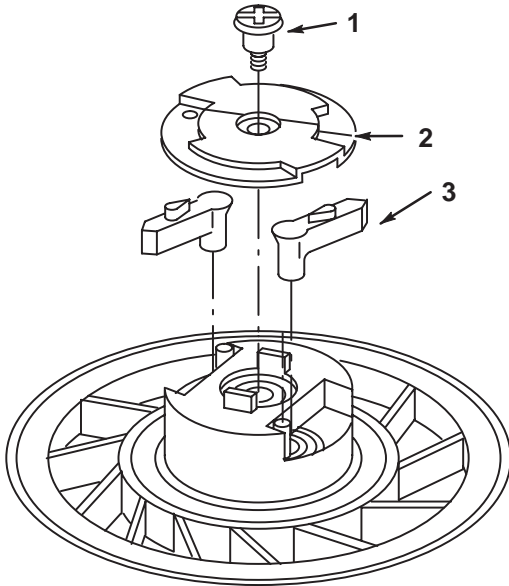

Fig. 72 – Removing Retainer

1. Shoulder screw
2. Retainer
3. Pawls

2. Lift out pawls.
3. Rotate pulley until pulley feels free.
4. Carefully lift out pulley with spring, Fig. 73.

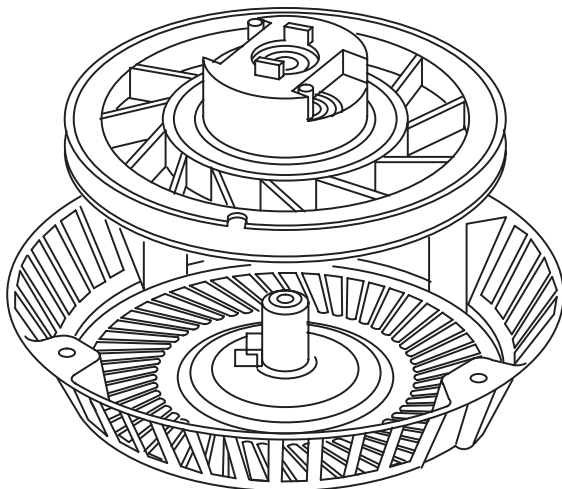

Fig. 73 – Removing Pulley

Inspect Spring, Starter Housing and Pulley

1. Inspect pulley for wear, cracks, rough edges or burrs in pulley groove and wear on center hole, Fig. 74.

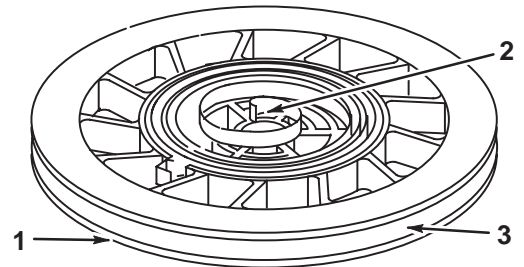

Fig. 74 – Inspecting Pulley

1. Edges
2. Center hole
3. Pulley groove

2. Replace pulley if damaged or worn.
3. Inspect spring for broken ends, kinks and burrs. Replace assembly if any of above conditions exists.
4. Inspect starter housing for wear or sharp edges at rope eyelet, center pivot post, and inner spring anchor, Fig. 75.

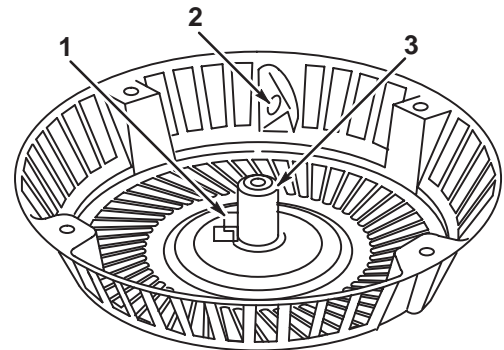

Fig. 75 – Inspecting Starter Housing

1. Inner spring anchor
2. Rope eyelet
3. Center pivot point

5. Replace assembly if worn or damaged.



CAUTION



PULLEY AND spring is serviced as an assembly. Do not remove spring from pulley.



WARNING



THE STARTER spring is still under tension when the rope has been removed and the pulley has no spring tension against it. Wear eye protection to prevent eye injury when installing or removing starter pulley and spring.

Assemble Rewind Starter

Install Pulley and Spring

1. Lay starter housing on work bench.
2. Assemble starter pulley to center pivot post in housing, Fig. 76.

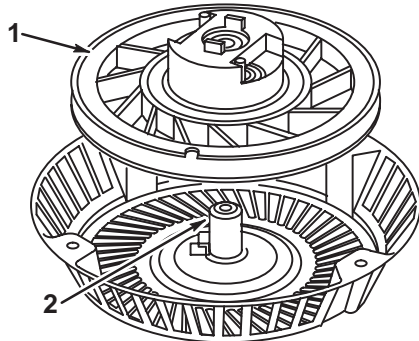

Fig. 76 – Installing Pulley

1. Pulley
2. Center pivot post

3. Rotate pulley counterclockwise until slight resistance is felt, indicating that spring is engaged in spring tab in housing, Fig. 77.

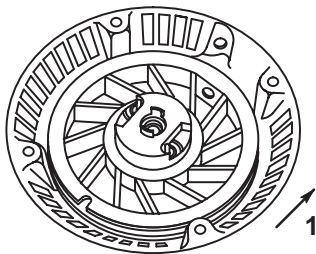

Fig. 77 – Engaging Spring

1. Counterclockwise

Install Pawls and Retainer Assembly

1. Position pawls over posts in pulley and install, Fig. 78.

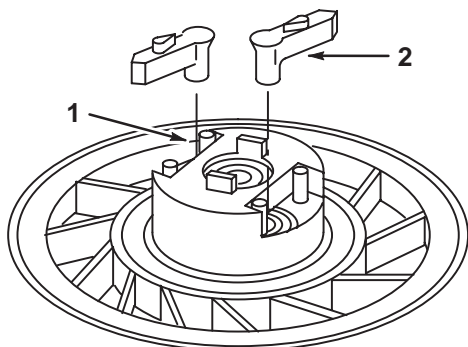

Fig. 78 – Installing Pawls

1. Posts
2. Pawls

2. Install retainer making sure that slots in retainer engage tabs on pulley, Fig. 79.

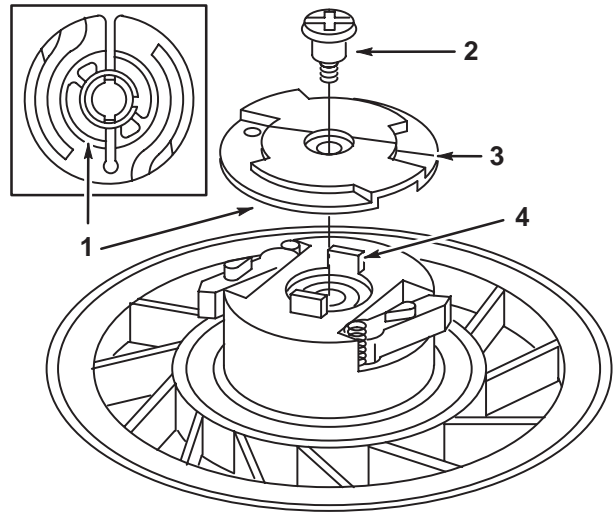

Fig. 79 – Installing Retainer and Screw

1. Slot
2. Torque screw to 70 in. lbs. (8.0Nm)
3. Retainer
4. Tab

3. Hold retainer down and install retainer screw. Torque screw to 70 in. lbs. (8.0Nm)
4. While holding retainer, rotate pulley to extend and retract pawls. If they do not extend and retract, remove retainer and install again.

Wind Spring and Install Rope

1. Turn pulley counterclockwise until spring is wound tight, Fig. 80.

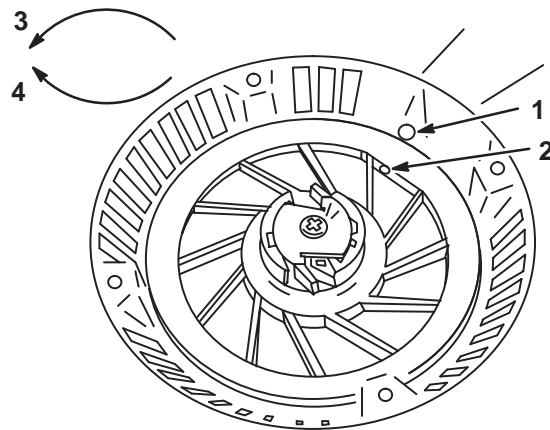

Fig. 80 – Winding Spring

1. Starter housing eyelet
2. Pulley rope hole
3. Counterclockwise
4. Clockwise

2. Then rotate pulley clockwise until rope hole in pulley is in line with starter housing eyelet and hold pulley, Fig. 80.

3. Insert unknotted end of rope through knot cavity and rope hole in pulley.
4. Thread end of rope through starter housing eyelet and pull rope until knot is in rope cavity, Fig. 81.

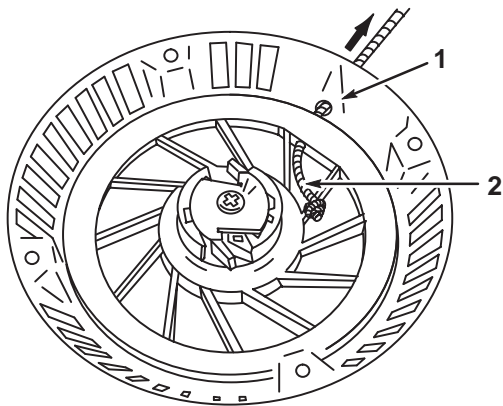

Fig. 81 – Inserting Rope

1. Starter housing eyelet
2. Pulley rope hole

5. While holding starter rope handle, slowly let pulley pull starter rope into starter.

Install Rewind Starter on Blower Housing

1. If rewind starter housing was removed from blower housing, see parts manual for screws and nuts.

Install Blower Housing and Rewind Starter

1. Place blower housing on engine and start one (1) screw in extruded hole.
2. Hold blower housing with extruded hole in recess of cylinder block, Fig. 82.

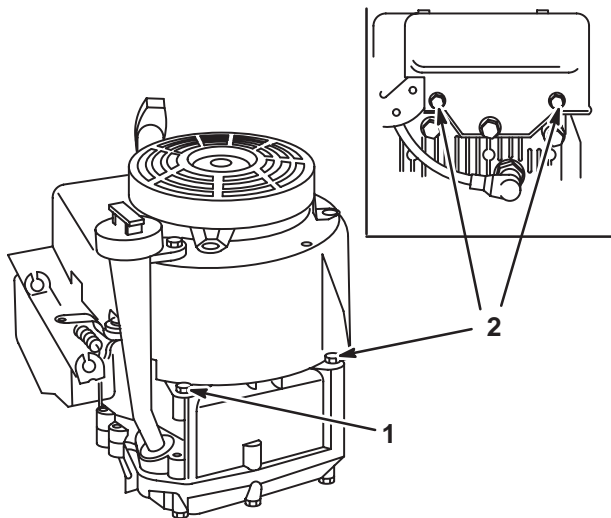

Fig. 82 – Installing Blower Housing

1. Tighten first
2. Tighten second

3. Tighten screw and then install three remaining screws. Install oil fill tube and dipstick.

Note: Install fuel tank bracket with blower housing. After torquing blower housing screws install one (1) screw at top of fuel tank bracket to top of blower housing and torque screw to 85 in. lbs. (10.0Nm).

4. Install oil fill tube and dipstick and torque screw to 45 in. lbs. (5.0Nm).

Note: The oil fill tube screw is installed on fuel tank bracket to same torque listed in Step 4.

Install Fuel Tank

1. Install fuel tank by sliding tank mounting bosses into slots on fuel tank bracket until tank bottoms in slots.
2. Start, but do not tighten screws into bottom of fuel tank bracket.
3. Install shoulder screw between fuel tank and side tank mounting boss. Install shoulder screw and torque screw to 85 in. lbs. (10.0Nm), Fig. 83.

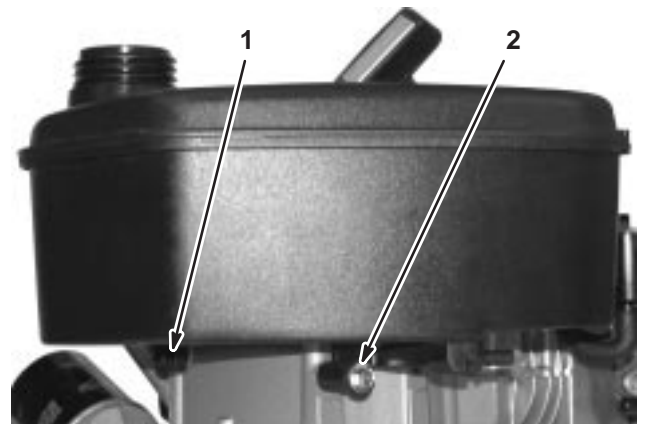

Fig. 83 – Installing Fuel Tank

1. Torque screw to 45 in. lbs. (5.0Nm)
2. Torque shoulder screw to 85 in. lbs. (9.6Nm)

4. Torque lower tank mounting screw to 45 in. lbs. (5.0Nm), Fig. 83.

Note: 21" commercial mowers use a remote fuel tank.

Electric Starter

Contents

General Information	38
Troubleshooting 12 Volt Starting System	38
Test Equipment	39
Digital Multimeter	39
DC Shunt	39
Tachometer	39
Starter Test Bracket	39
Other Equipment	39
Battery	40
Handling Instructions	40
First Aid	40
Check Battery	40
Replace Battery Terminal	40
Starter	41
Check Starter Motor Drive and Clutch	41
Wiring Diagrams	41
Check 12 Volt Starter Motor	41
Starter Motor Specifications	41
Troubleshoot Starter Motor	41
Check Brake Switch	42
Check Brake Switch Wiring	42
Disassemble Starter Motor	42
Clean and Inspect Starter	43
Assemble Starter Motor	43
Install Starter	44

General Information

The Toro GTS 200 electric start system consists of a 12V battery, starter motor, switch, and alternator. In addition, the 1999 and newer models have a brake switch and a fuse for the charging system. A separate trickle charger is also standard.

The starter motor uses a gear type engagement method, similar to an automobile starter. The starter motor shaft drives a pinion gear into engagement with a ring gear attached to the engine flywheel and cranks the engine. See Fig. 84 for location of starter motor.

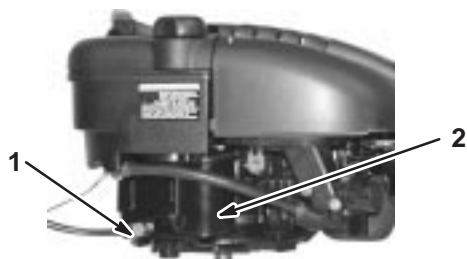

Fig. 84 – Electric Start Engine

1. Connector 2. 12 volt starter motor

When the starter switch is activated, the battery supplies power to the starter motor, cranking the engine. On 1999 and newer models, the brake switch must also be activated to power the starter. When the engine is running, the alternator recharges the battery. It will take approximately 15–20 minutes of running to replace the battery charge used to start the engine one time.

Should the battery need additional recharging, the trickle charger is plugged into a 120 volt AC household outlet, and then connected to battery. The battery will be fully charged within a 72 hour period. It is not recommended that battery be recharged if temperatures are below 40° F (4° C). For best results, charge battery within temperature limits of 40° F (4° C) to 105° F (41° C). When long periods of storage are encountered, battery should be charged overnight every two months. This type of battery will lose its charge when not in use. This may shorten battery life.

Troubleshooting 12 Volt Starting System

The following list is given to aid in diagnosing problems for 12 volt starting systems.

Note: If a starting problem is encountered, the engine itself should be thoroughly checked to eliminate it as the cause of starting difficulty. It is a good practice to check engine for freedom of rotation by removing spark plug and turning crankshaft over by hand, to be sure it rotates freely.

1. Engine Cranks Slowly

- A. Additional load affecting performance.
- B. Discharged battery.
- C. Faulty electrical connection (battery circuit).
- D. Dirty or worn starter motor commutator, bearing, weak magnets, etc.
- E. Worn brushes or weak brush springs.
- F. Wrong oil viscosity for temperature expected.
- G. Flywheel brake mis-adjusted.

2. Engine Will Not Crank

- A. Discharged or defective battery.
- B. Faulty electrical connections.
- C. Faulty starter motor switch (open circuit).
- D. Open circuit in starter motor.
- E. Brushes sticking, etc.

3. Starter Motor Spins, But Does Not Crank Engine

- A. Sticking pinion gear due to dirt or damaged spline.
- B. Damaged pinion or ring gear.
- C. Starter pinion clutch slipping.

- D. Battery faulty or damaged.
- E. Incorrect rotation due to reversed motor polarity or reverse battery connections – motor rotates counterclockwise viewed from pinion gear.

4. Starter Motor Spins, Will Not Stop

- A. Defective starter switch.

Test Equipment

The following is a list of equipment recommended to test and repair starter motors , and to test batteries.

Digital Multimeter

A Digital Multimeter is recommended. The meter may be used to read volts, ohms or amperes, and test diodes (rectifiers) when test leads are inserted in the appropriate receptacle, Fig. 85.

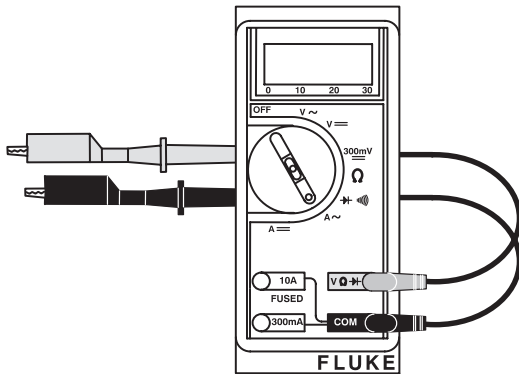

Fig. 85 – Digital Multimeter

DC Shunt

Use with Digital Multimeter. The DC Shunt may be used to read starter motor current draw on 12 volt starter motors. Use Briggs & Stratton Tool #19359, Fig. 86.

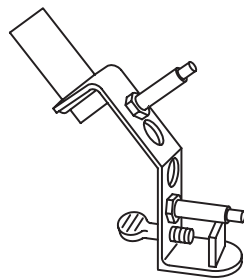

Fig. 86 – DC Shunt

Tachometer

A Trysit Sirometer (Tachometer) is available from your Briggs & Stratton source of supply. Use Briggs & Stratton Tool #19200. The Sirometer measures from 800 to 25,000 revolutions per minute (RPM), Fig. 87.

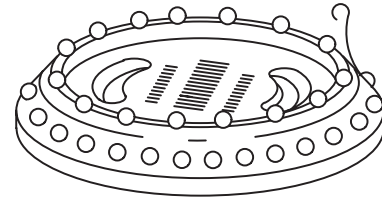

Fig. 87 – Trysit Sirometer (Tachometer)

Starter Test Bracket

A starter motor test bracket may be made as shown in Fig. 88.

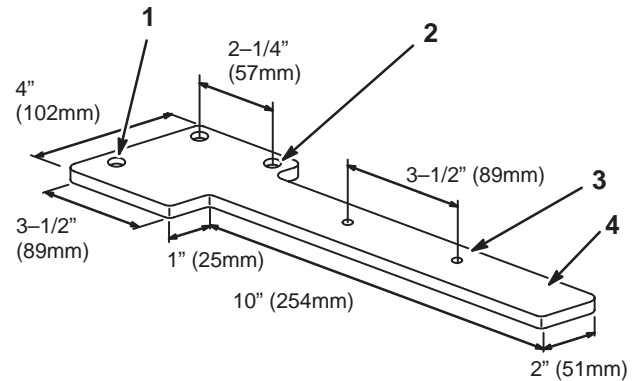

Fig. 88 – Starter Mounting Test Bracket

- 1. Extra hole for mounting starter brackets
- 2. Drill two holes 3/8" (10mm) diameter for starter mounting bracket
- 3. Drill two holes for mounting Briggs & Stratton Tool #19200 tachometer #7 drill tap hole for 1/4–20 NC screws
- 4. Metal stock 1/4" (6mm) thick steel

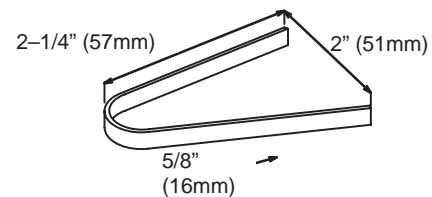

Fig. 89 – Brush Spreader

Other Equipment

A growler or armature tester (checks armature for continuity, shorts and opens) is available from an Automobile Diagnostic Service supplier.

A known good 12 volt battery is required when testing 12 volt starting systems.

Battery

Handling Instructions



CAUTION



LIKE ALL batteries, these units contain corrosive fluids and toxic materials and should be handled with care.

- Do not puncture, disassemble, mutilate or incinerate.
- As with all rechargeable batteries, explosive gases could be vented during charge or discharge. Use in a well ventilated area, away from sources of ignition.
- Battery should be recharged by adults only.
- Use only the battery charger specified.
- Do not make direct contact between the positive and negative terminals as this could cause high current flow, creating high heat and the possibility of a fire.
- Avoid any direct connection of battery terminals that will cause the battery to short out.

First Aid



CAUTION



IF THE battery case cracks or breaks open as the result of severe abuse and some of the liquid comes in contact with skin or clothing, follow these instructions:

- **External Contact** – Immediately flush skin or eyes with water for at least 15 minutes.
- **Internal Contact** – Drink tap water, milk, or milk of magnesia. Take whites of eggs. Do not induce vomiting.



WARNING



IN CASE of external or internal contact, call a physician immediately.

Check Battery

1. Physical check – clean if necessary.
 - A. Corrosion
 - B. Dirt
 - C. Terminal – clean, undamaged. Replace if damaged with Toro Part #49-8141.

2. Fully charge battery with charger supplied with the mower.
3. Install battery on mower. Plug into wire harness.
4. Slightly loosen battery plug and attach DC voltmeter. Reading should be around 12.5 VDC.
5. Disconnect spark plug wire and turn switch to start.
6. Battery should maintain 9 volts or more while cranking engine. If it is less than 9 volts, replace battery.

Alternate method: Test using Toro Keylectric tester, Toro Part #67-7970, Fig. 90. Instructions provided on tester.



Fig. 90 – Keylectric Tester



CAUTION



DO NOT crank starter motor for more than 15 seconds without cooling starter 2 minutes.

Replace Battery Terminal

Toro Part #49-8141 is a replacement plug with two solderless connectors (Fig. 91). It can be used when the plug or lead wires between the plug and battery are damaged.



Fig. 91 – Replacement Battery Terminal
Toro Part #49-8141

Starter

Check Starter Motor Drive and Clutch

1. When starter switch is activated, pinion gear should rise, engage flywheel ring gear, and crank engine. This should be observed.
2. If starter motor drive does not react properly, inspect helix and pinion gear for freeness of operation.
3. Pinion gear must move freely on helix for correct starter operation. If any sticking occurs, this must be corrected, Fig. 92.

Note: Do not oil pinion gear on clutch helix.

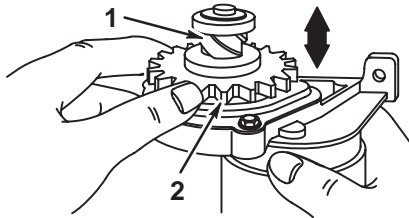

Fig. 92 – Starter Motor Drive

1. Helix
 2. Starter gear
-
4. Starter motor clutch is designed to prevent damage from shock loads such as an engine backfire.
 5. Clutch should not slip during normal engine cranking. This can be checked by blocking mower blade and engaging starter motor.
 6. If clutch assembly slips at this time, it should be replaced.

Wiring Diagrams

The following wiring diagrams (Fig. 93) show the two systems used with the GTS 200 engine.

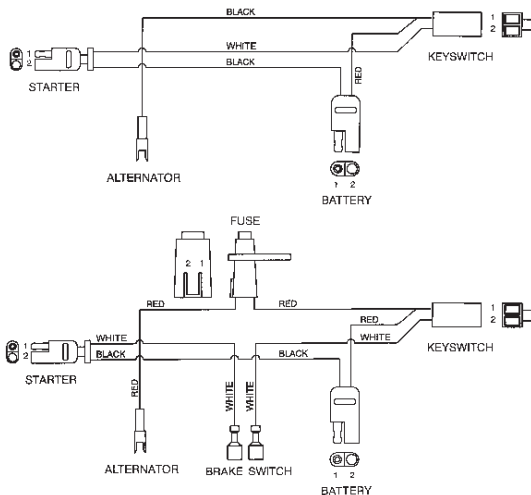

Fig. 93 – Typical Wiring Diagrams for Toro Walk Behind Mowers

Check 12 Volt Starter Motor

A performance test of starter motor may be made in the following manner.

! **CAUTION** !

GROUND SPARK plug wire using Briggs & Stratton Tool #19051 or #19368, Ignition Tester, before doing this test. Do not engage starter motor more than five seconds.

1. Set multimeter to read DC amps. Multimeter must be capable of reading 10 amps DC minimum.
2. Connect starter motor, battery and meter as shown in Fig. 94.
3. Place tachometer on starter body and activate starter motor as shown, Fig. 94.

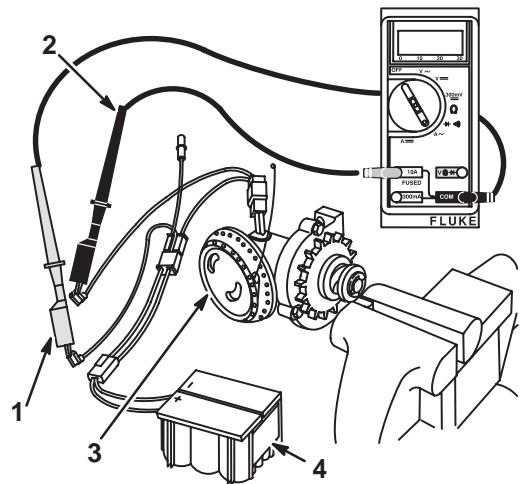

Fig. 94 – Testing Starter Motor with Digital Multimeter

1. Red test lead
2. Black test lead
3. Briggs & Stratton Tool #19200
4. 12 volt battery

Starter Motor Specifications

Voltage 12
Minimum motor RPM 1400
Maximum amps 9

Troubleshoot Starter Motor

If starter motor does not perform satisfactorily, following should be checked, and corrected if necessary.

1. A binding condition between pinion and clutch gear or misalignment of motor bearings.
2. Starter motor brushes sticking in brush holders.

3. A dirty or worn armature commutator.
4. A shorted, open or grounded armature.
 - A. Shorted armature (worn insulation, wires touching each other) will be indicated by slow speed and high current (amps).
 - B. Open armature (broken wire) may not turn (no current flow [amps]) or will have low RPM.
 - C. Grounded armature (worn insulation, wire touching armature) will not turn or may turn slowly and will have excessive current (amps).
 - D. Weak, loose, or cracked magnets.
5. Armature end play, too much or none.
6. Defective starter motor brake switch.

Check Brake Switch

1. Disconnect interlock switch wires from spade terminals on switch.
2. Set meter to read Ω ohms. Zero meter, if required.
3. Connect meter test leads to two spade terminals of switch (Fig. 95). Meter should read no continuity.



Fig. 95 – Checking the Brake Switch

4. Push switch lever in until switch clicks. Meter should read low resistance.

Check Brake Switch Wiring

1. Disconnect interlock switch wires from spade terminals on switch and at starter motor connector.
2. Set meter to read Ω ohms. Zero meter, if required.
3. Connect one meter test lead to end of one wire inside connector and other test lead to second connector terminal for the same wire.
4. Meter should read low or no resistance.

5. Move wire inside connector. Meter should not change value.
6. Replace or repair wiring if there is no continuity or intermittent. Repeat for each wire in harness.

Disassemble Starter Motor

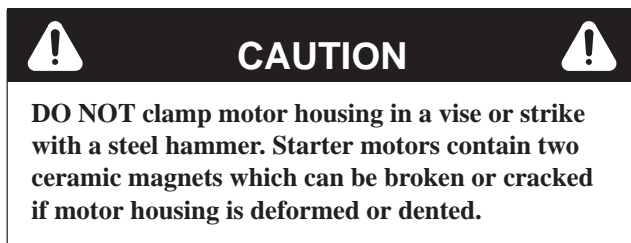

1. Study Fig. 96 prior to starter motor disassembly.

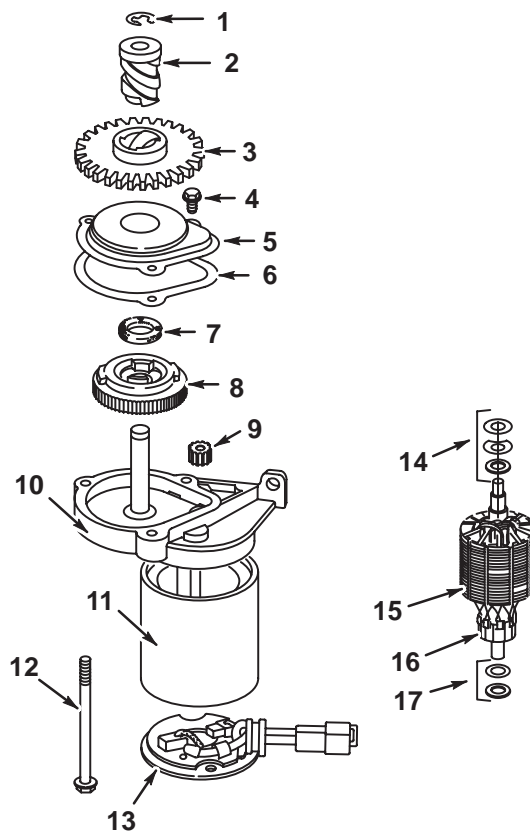

Fig. 96 – Exploded View

- | | |
|----------------------------|---|
| 1. "E" retaining ring | 11. Thru bolts (2) |
| 2. Starter gear helix | 12. Housing |
| 3. Pinion gear | 13. Brush end cap (with brushes, springs, and connectors) |
| 4. Screws (3) | 14. End play washers |
| 5. Cover | 15. Armature |
| 6. Gasket | 16. Commutator |
| 7. Felt washer | 17. Thrust washers |
| 8. Drive gear | |
| 9. Pinion gear | |
| 10. Drive end head bracket | |

2. Remove "E" retaining ring and pinion gear.

- Three (3) screws holding gear cover and gear itself may now be removed.
- Lift clutch assembly and pinion gear off their respective shafts.
- Remove starter motor thru bolts, Fig. 97.

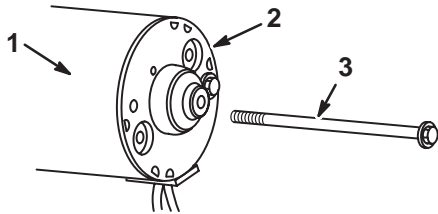

Fig. 97 – Removing Thru Bolts

- Housing
- End cap
- Remove thru bolts

- Separate motor end cap from motor housing.
- Push motor armature out through bottom of starter housing, taking care to slide plastic mounted terminal out of motor housing along with end cap, Fig. 98.

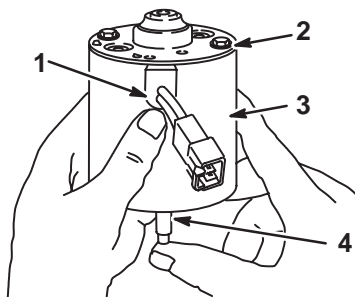

Fig. 98 – Removing Armature

- Terminal
- End cap
- Housing
- Armature shaft

- Before removing armature from end cap, check brushes for freedom of movement.
- If brushes are found to be sticking in their retainers, this must be corrected, or poor starter motor performance will result, Fig. 99.

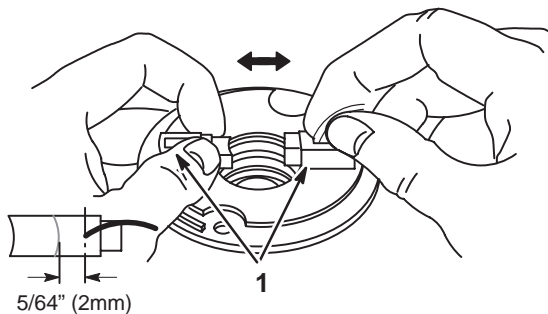

Fig. 99 – Checking Brushes

- Brushes

- If brushes are worn to a length of 5/64" (2mm) or less, brushes should be replaced.
- Check brush springs for proper tension (sufficient force to keep brush in firm contact with commutator).

Clean and Inspect Starter

- Clean all dirt from armature, end cap, motor support, gears, etc.
- End cap bearings and armature should not be soaked in a solvent.
- Armature commutator may be cleaned with a fine sandpaper or commutator paper.

Note: Do not use any metallic oxide paper or emery cloth, as metallic oxide or emery will become embedded in commutator causing rapid brush wear.

- If armature is suspected to be defective, a new armature should be tried in motor.
- If proper testing equipment is available, check suspected armature to determine if it is defective.

Starter motor armatures have very low resistance, usually below detection on available multimeters. To check for shorted armatures, a piece of equipment known as a "growler" may be used. If this equipment is not available, a known good armature should be tried and performance rechecked.

If magnets are loose or cracked, a new motor housing should be tried.

Assemble Starter Motor

- When all parts have been thoroughly inspected, lightly lubricate bearings with an oil made for use in electric motors and reassemble in following manner.
- Insert brush springs and brushes in holders as far as possible, and hold them in this position with tool shown in Figs. 89 and 100.

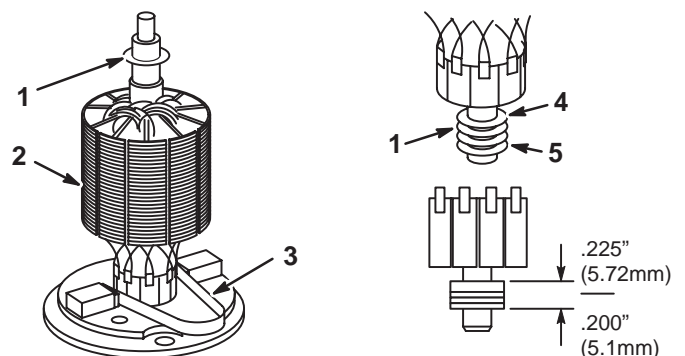

Fig. 100 – Armature Assembly to End Cap

- Gray plastic washers
- Armature
- Brush spreader
- .176" (4.47mm) thick fiber washer
- .030" (.76mm) thick steel washer

3. Place thrust washers on armature shaft in sequence shown.
4. Add gray plastic washers to obtain dimension shown in Fig. 100, inset.
5. Using care to ensure brushes clear commutator, slide armature shaft into end cap bearing.
6. Support armature shaft and slide it slowly into starter housing, as shown in Fig. 101.

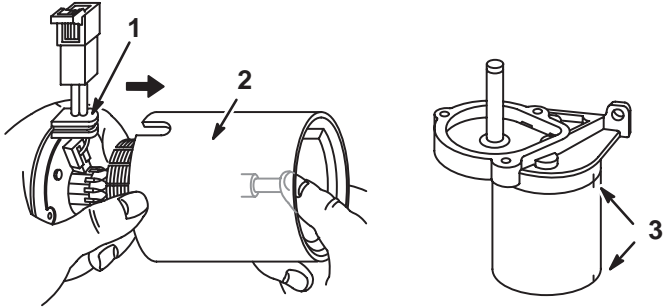

Fig. 101 – Inserting Armature

1. Terminal
2. Housing
3. Notch

7. Insert plastic insulator terminal into starter housing at this time.
8. Place remaining thrust washers on motor PTO shaft. Install end head cover and thru bolts.
9. Torque through bolts to 25 in. lbs (3.0Nm).
10. Notches in end cap, housing and end head must be aligned, Fig. 101.
11. Check for end play to obtain .005” (13mm) to .025” (64mm) armature movement.
12. If required, install or remove gray plastic washers between armature and drive end head to obtain end play.
13. Slip pinion and starter motor clutch gear on shaft.
14. Add approximately 3/4 ounce of Briggs & Stratton Part #100060 grease under large gear and on gear teeth.
15. Oil felt washer with electric motor oil.
16. Install washer, gasket and cover, Fig. 102.

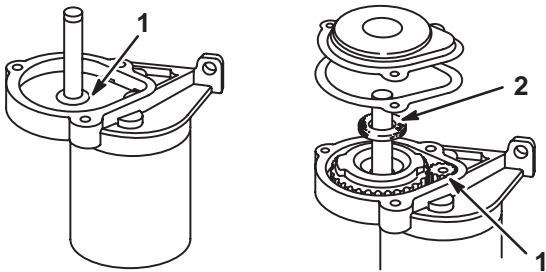

Fig. 102 – Lubricating Gears

1. Apply lubricant here
2. Oil felt washer

17. Tap end cap edge lightly using a soft hammer to align bearings, Fig. 103.

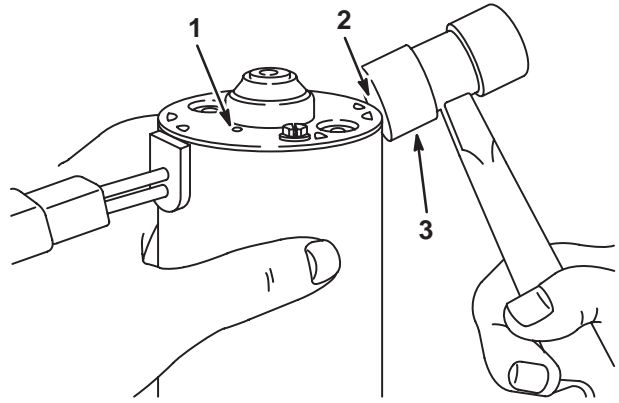

Fig. 103 – Aligning End Cap Bearing

1. Drain hole
2. Tap edge of end cap
3. Soft hammer

18. Re-torque screws to 25 in. lbs. (3.0Nm).
19. Replace pinion gear and “E” retaining ring assembly.

Note: Do not oil pinion gear or clutch helix.

Install Starter

1. Install starter on engine and start mounting screws. While holding starter against locating lugs on cylinder, Fig. 104, torque mounting screws to 140 in. lbs. (16.0Nm).
2. Reinstall starter guard, when used.

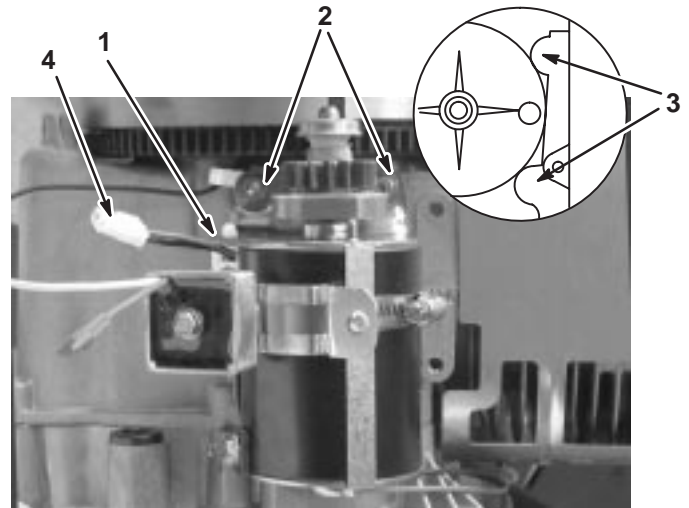

Fig. 104 – Installing Starter

1. Wire clip
2. Torque screws to 140 in. lbs. (16.0Nm)
3. Lug
4. Alternator wire(s)

Alternator

Contents

Alternator Specifications	45
Equipment to Test Alternators	45
Digital Multimeter	45
1/2 Amp Alternator	45
Test Alternator Output	45
Install Stator Studs	46
Adjust Stator Air Gap	46

Alternator Specifications

Alternator type DC only

Alternator output* not less than
(at 2800 RPM) 0.5 amps DC (+)

* Alternator output is determined by flywheel alternator magnet size.

Note: Alternator is rated at 2800 RPM. Output is reduced as engine speed is lowered.

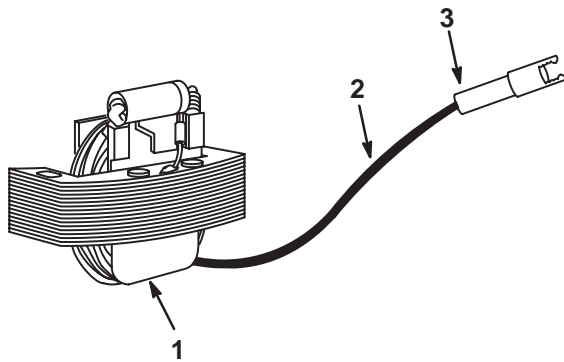

Fig. 105 – 1/2 Amp

- 0.5 amps DC for charging battery.
 - One black lead from stator.
 - White connector output lead.
1. Stator assembly
 2. Black
 3. White

Alternator Systems – Troubleshooting

Complaint	Possible Causes
Battery not charging	<ul style="list-style-type: none"> • Engine RPM too low. • Defective battery. • Loose, pinched, or corroded battery ground leads. • Loose, pinched, or corroded battery charge leads. • Open, shorted, or grounded wires between output connector and battery. • Damaged battery (shorted battery cells). • Damaged alternator magnets. • Defective stator.

Equipment to Test Alternators

The following equipment is recommended to test and repair alternators.

Digital Multimeter

Use a Digital Multimeter. The meter may be used to read volts, ohms or amperes, and test diodes, when leads are inserted in appropriate receptacles, Fig. 106.

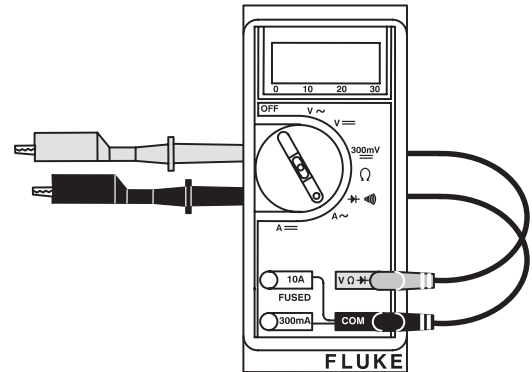

Fig. 106 – Digital Multimeter

1/2 Amp Alternator

The 1/2 amp DC alternator is designed to operate as an integral part of the engine and is separate from the starting and ignition system. It is intended to provide DC charging current for a 12 volt battery.

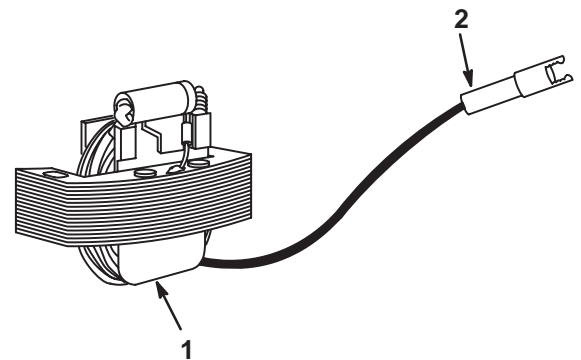

Fig. 107 – 1/2 Amp Alternator

1. Stator assembly
2. Black

Test Alternator Output

Disconnect charging lead to battery at connector.

1. Insert RED test lead into 10 A receptacle in meter.
2. Insert BLACK test lead into COM receptacle in meter.
3. Rotate selector to **A** == (DC amps) position.

4. Attach RED test clip to output terminal, Fig. 108.

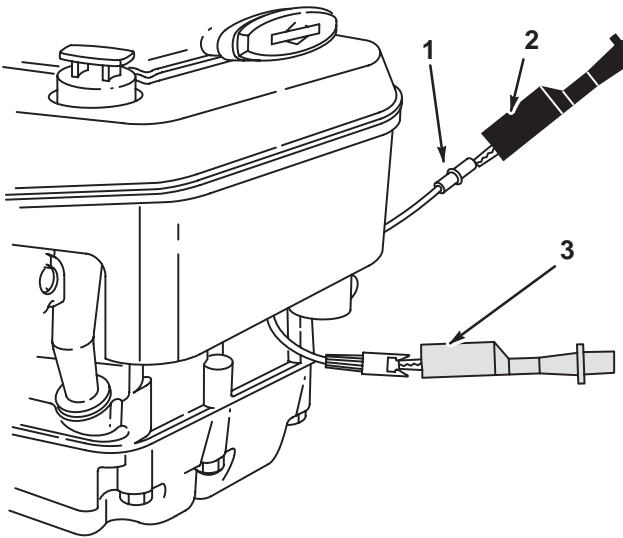

Fig. 108 – Testing Alternator Output

1. Connector
2. Black lead
3. Red lead

5. Attach BLACK test clip to charging lead that was disconnected at the connector.
6. With engine running at least 2800 RPM, output should be no less than 0.5 amp DC.
7. If low or no output, check stator air gap, Fig. 109.

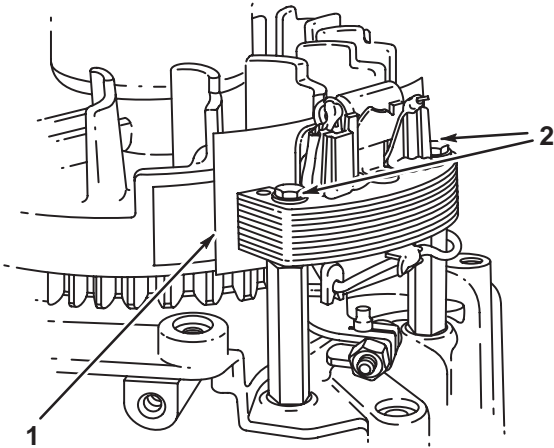

Fig. 109 – Adjusting Air Gap

1. 0.010" (.25mm) gauge
2. 25 in. lbs. (2.8Nm)

8. If stator air gap is within specification and there is low or no output, replace stator.

Install Stator Studs

If stator studs were removed, install and torque to 30 in. lbs. (3.4Nm), Fig. 109.

Adjust Stator Air Gap

1. Stator air gap is 0.010" (.25mm).
2. Rotate flywheel until magnets are away from stator.
3. Loosen both stator mounting screws and move stator away from flywheel and tighten one screw.
4. Place a 0.010" (.25mm) thick gauge between stator and flywheel.
5. Turn flywheel until magnets are under stator. Loosen screw and let stator be pulled against flywheel magnet.
6. Torque mounting screws to 25 in. lbs. (2.8Nm).
7. Turn flywheel to remove gauge, Fig. 109.

Lubrication

Contents

Extended Oil Fill and Dipstick	47
Breather	47
Remove Breather	47
Install Breather Valve	47
Remove Oil Pump	47
Inspect Oil Pump	48
Install Oil Pump	48
Install Pump Cover	48
Install Oil Filter Adapter	48

Extended Oil Fill and Dipstick

The GTS 200 uses a plastic extended oil fill tube and a quarter turn screw-on-dipstick.

Dipstick oil fill tube is pressed into crankcase cover.

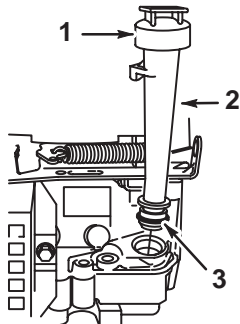

Fig. 110 – Oil Fill and Dipstick

- | | |
|------------------|-------------|
| 1. Dipstick | 3. "O" ring |
| 2. Oil fill tube | |

Breather

The GTS 200 engine uses a breather valve to control and maintain a partial vacuum in the crankcase.

The breather valve is a fiber disc or reed valve which closes on the piston's up stroke and opens on the piston's down stroke to keep a partial vacuum in the crankcase.

This partial vacuum prevents oil leakage past piston rings, valve guides, oil seals, governor lever shaft and gaskets.

Remove Breather

1. Before breather can be removed, remove fuel tank, extended oil fill tube, blower housing, flywheel, and muffler.
2. Remove two screws holding breather to cylinder, Fig. 111.
3. Remove four screws holding breather passage cover and gasket, Fig. 111.

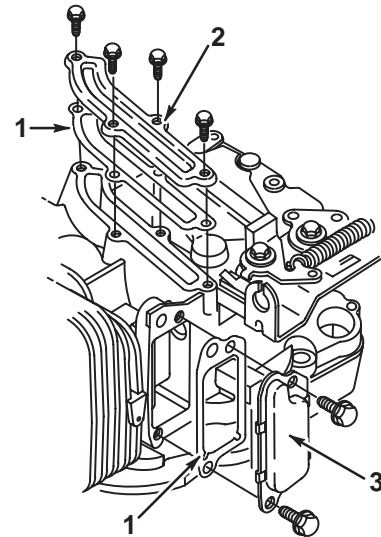

Fig. 111 – Removing Breather and Breather Passage Cover

- | | |
|---------------------------|-------------|
| 1. Gasket | 3. Breather |
| 2. Breather passage cover | |

Install Breather Valve

1. Install new breather passage gasket and breather passage cover on cylinder channel and torque four (4) screws to 30 in. lbs. (3.0Nm).
2. Place new breather gasket and breather on cylinder and install two (2) screws torquing screws to 65 in. lbs. (7.0Nm), Fig. 111.

Gaskets do not require any sealant.

Remove Oil Pump

(on models so equipped)

1. Oil pump can be removed without removing sump from engine.
2. Remove three screws and remove pump cover and "O" ring, Figs. 112 and 113.
3. Carefully remove inner and outer rotors.

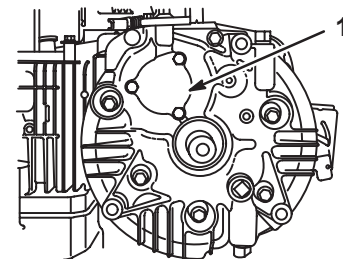

Fig. 112 – Removing Pump Cover

1. Oil pump cover

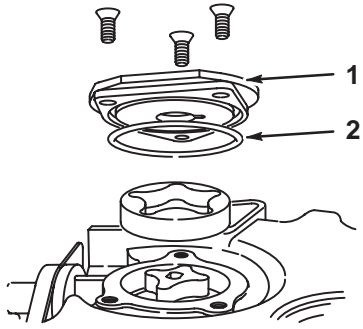

Fig. 113 – Removing Oil Pump

1. Pump cover
2. "O" ring

Inspect Oil Pump

(on models so equipped)

1. Inspect surfaces of inner and outer rotors, pump housing, cover, and shaft for wear and scoring.
2. Inspect pump housing and passages for debris.
3. Clean if required.
4. Replace worn or damaged parts.

Install Oil Pump

(on models so equipped)

1. Oil and install outer rotor in pump cavity. Do not use force to install.
2. Oil and install inner rotor in pump cavity.
3. Turn rotors to engage pump in cam or governor gear.
4. Place "O" ring in groove in cover, Fig. 114.

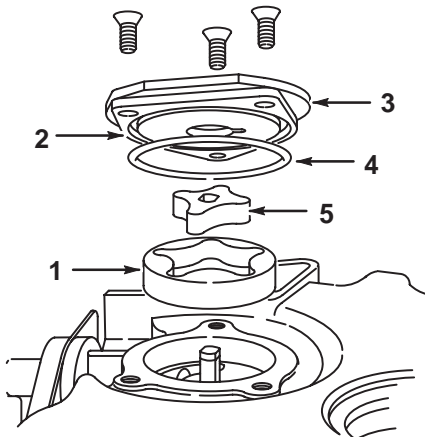

Fig. 114 – Installing Oil Pump

1. Outer rotor
2. Groove
3. Cover
4. "O" ring
5. Inner rotor

Install Pump Cover

(on models so equipped)

1. Install "O" ring in groove in sump, Fig. 115.

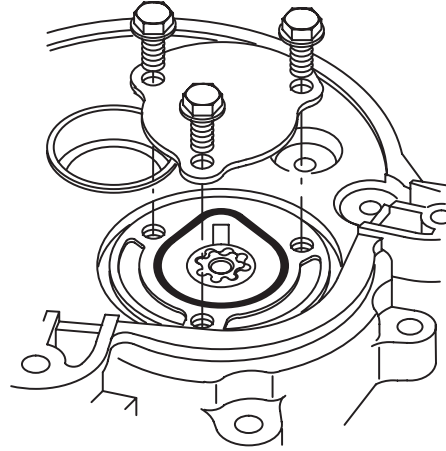

Fig. 115 – Installing Pump Cover

2. Place pump cover on oil pump cavity and install three (3) screws. Torque screws to 35 in. lbs. (4.0Nm).

Install Oil Filter Adapter

(on models so equipped)

Install oil filter adapter as shown in Fig. 116. Torque screws to 85 in. lbs. (10.0Nm).

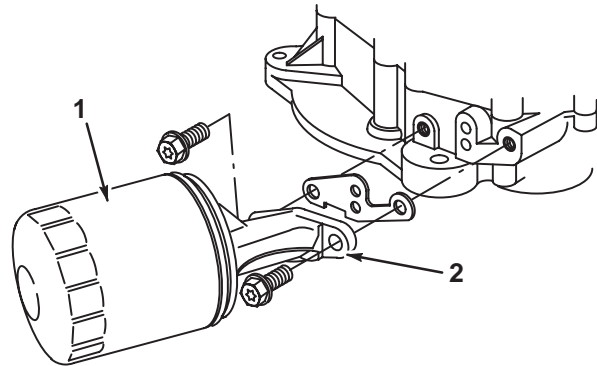

Fig. 116 – Oil Filter Adapter

1. Filter
2. Adapter

Pistons, Rings, and Rods

Contents

Piston and Connecting Rod	49
Remove Piston and Connecting Rod	49
Remove Piston Rings	49
Check Piston Ring Groove Wear	50
Check Piston Ring End Gap	50
Check Connecting Rod	50
Check Piston Pin and Piston Pin Bore	50
Assemble Piston and Connecting Rod	50
Install Piston Rings On Piston	51
Compress Rings	51
Install Connecting Rod and Piston	51
Specification Tables	52

Piston and Connecting Rod

Note: Crankcase cover or sump must be removed before piston and rod can be removed, Crankshaft and Camshaft, page 53.

Remove Piston and Connecting Rod

1. Remove connecting rod cap, Fig. 117.

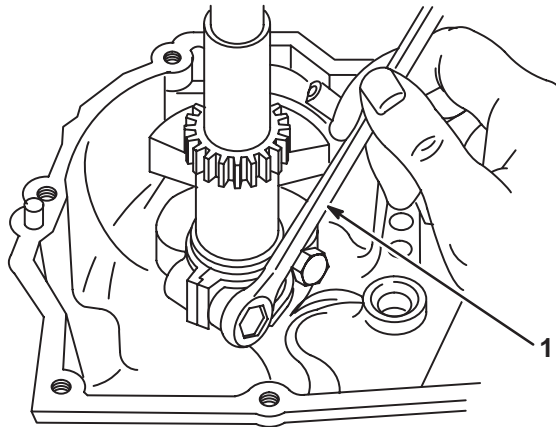

Fig. 117 – Remove Piston and Connecting Rod

1. Box wrench to remove screws

2. Remove any carbon or ridge at top of cylinder bore to prevent ring breakage.

3. Push piston and rod out through top of cylinder.

Note: The GTS 200 engine uses oil drain slots in ring lands, Fig. 118.

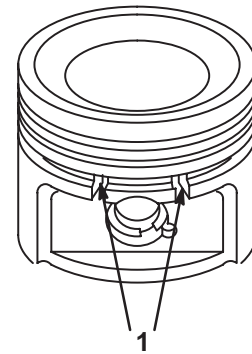

Fig. 118 – Oil Control Slots

1. Drain slot

Remove Piston Rings

Remove piston rings using Briggs & Stratton Tool #19340, Piston Ring Expander, Fig. 119.

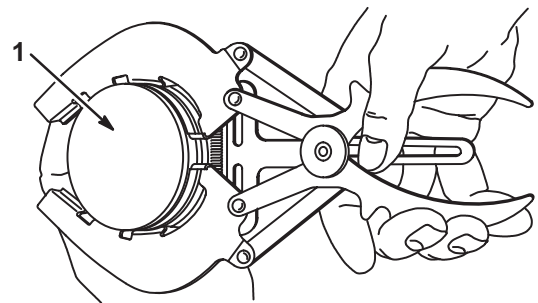

Fig. 119 – Removing Rings

1. Piston

Note: Some oil control rings consist of two thin steel rails and a spring expander. These steel rails cannot be removed with Briggs & Stratton Tool #19340, Piston Ring Expander.

1. Grasp one end of the steel rail and wind the rail from the oil ring groove into the next ring groove.
2. Repeat into the top ring groove and off the piston.

Check Piston Ring Groove Wear

1. Clean carbon from top ring groove.
2. Place a NEW ring in groove, Fig. 120 and measure space between ring and ring land, Table No. 1, page 52.

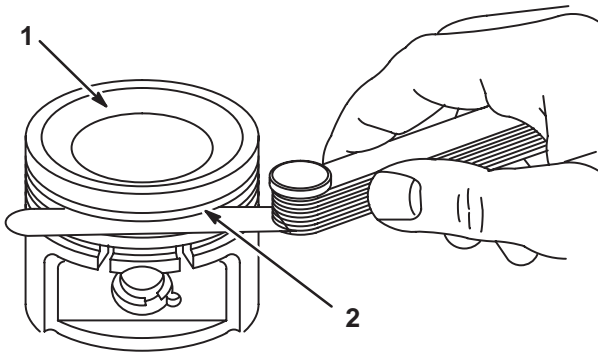

Fig. 120 – Checking Ring Grooves

1. Piston
2. New piston ring

Check Piston Ring End Gap

1. Clean all carbon from the end of the rings, and from the cylinder bore.
2. Insert old rings one at a time one inch down into the cylinder.
3. Check end gap with feeler gauge, Fig. 121.

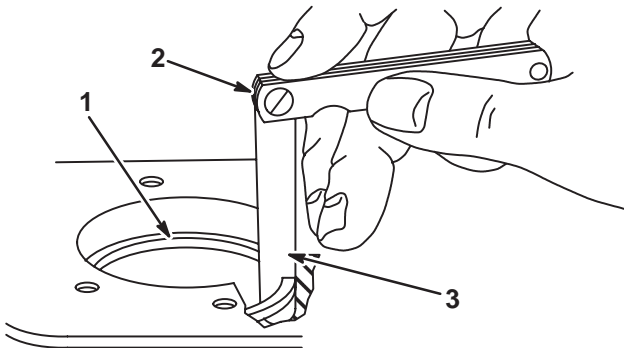

Fig. 121 – Checking Ring End Gap

1. Ring
2. Feeler gauge
3. See Table 1

4. If ring gap is greater than shown in Table No. 2, page 52, the ring should be rejected.

Check Connecting Rod

If the crankpin bearing is scored, the rod must be replaced. Check condition of crankpin bearing surface on crankshaft.

Reject sizes of crankpin bearing hole and piston pin bearing hole, Fig. 122, are shown in Table No. 3, page 52.

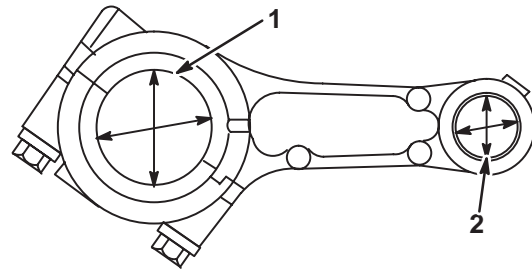

Fig. 122 – Checking Rod Bearings

1. Crankpin bearing
2. Piston pin bearing

Check Piston Pin and Piston Pin Bore

If piston pin is worn .0005" (.013mm) out of round or below reject size shown in Table 4, it should be replaced.

If piston pin bore, Fig. 123, is worn over reject size, replace piston.

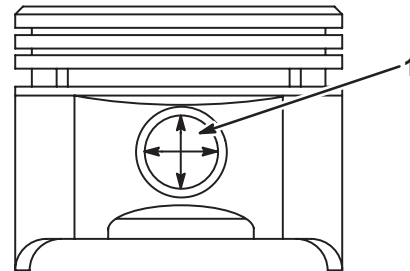

Fig. 123 – Checking Piston Pin Bore

1. Piston pin bore

Assemble Piston and Connecting Rod

Note: Pistons on the GTS 200 engine have a shoulder stop on one side of piston and use only one (1) piston pin lock.

The piston pin is a slip fit in both piston and connecting rod.

Note: All pistons are made with an offset piston pin bore.

1. Piston must be installed with notch or arrow toward flywheel side of cylinder.
2. Determine correct position of connecting rod relative to notch or arrow on piston, Fig. 124.

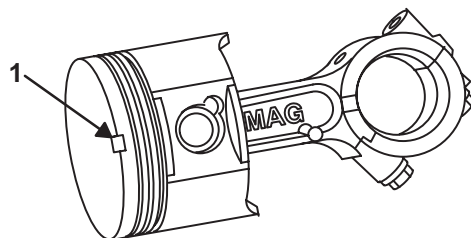

Fig. 124 – Assembling Piston and Rod

1. Notch or arrow

3. Insert piston pin from side opposite shoulder or installed lock until pin stops against lock or shoulder.
4. Install piston pin lock in groove at other end of piston pin.
5. Be sure lock is firmly set in groove.

Note: Some rods have the word “MAG” cast in the rod on the flywheel side.

Install Piston Rings On Piston

The correct piston ring positions are shown in Fig. 125.

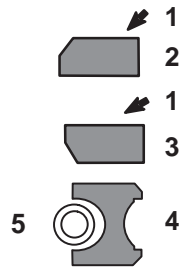

Fig. 125 – Piston Ring Installation

- | | |
|------------|-------------|
| 1. ID mark | 4. Oil |
| 2. Top | 5. Expander |
| 3. Center | |

Compress Rings

1. Oil piston rings and piston skirt.
2. Compress rings with Briggs & Stratton Tool #19070, Ring Compressor, Fig. 126.

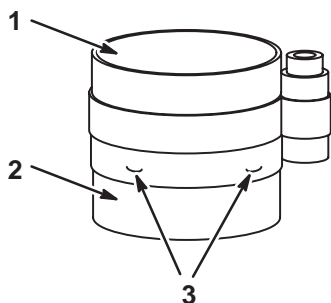

Fig. 126 – Compressing Rings

- | | |
|----------|---------------|
| 1. Top | 3. Projection |
| 2. Skirt | |

3. Place piston and compressor upside down on bench and push piston down until head of piston is even with edge of compressor.
4. Tighten compressor until piston cannot be turned in compressor.
5. Then loosen compressor until piston can be turned with slight resistance.

Note: Do not attempt to install piston and ring assembly without ring compressor.

Install Connecting Rod and Piston

1. Thoroughly clean and then oil cylinder bore.
2. Rotate crankshaft until crankpin journal is at bottom of stroke.

Note: This permits complete entry of compressed rings, piston and rod assembly, when pushed into cylinder, Fig. 127.

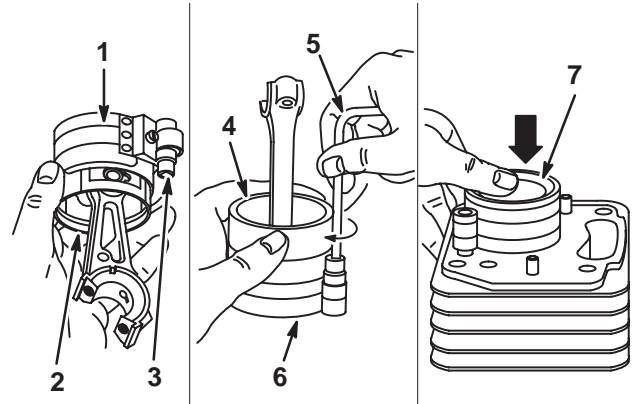

Fig. 127 – Installing Piston Assembly

- | | |
|---------------------------|--|
| 1. #19070 ring compressor | 5. Wrench |
| 2. Piston skirt | 6. Top of piston and ring compressor flush |
| 3. Square hole | 7. Top of piston |
| 4. Piston | |

3. Install piston with notch or arrow toward flywheel side of engine, Fig. 128, taking care not to damage crankpin journal or connecting rod journal, when installing.

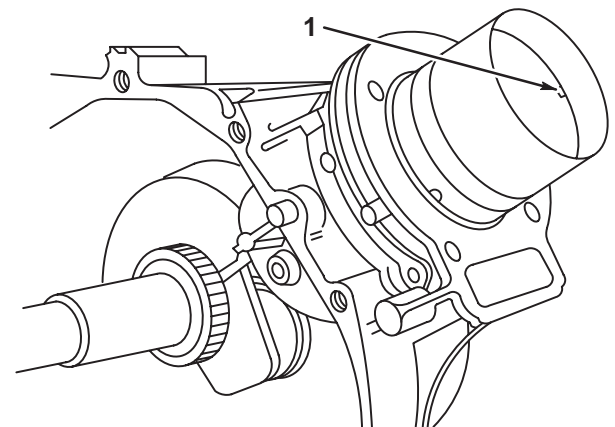

Fig. 128 – Installing Piston Assembly

1. Notch or arrow
4. Clean and oil crankshaft crankpin.

- Pull connecting rod against crankpin and install rod cap with match marks aligned, Fig. 129.

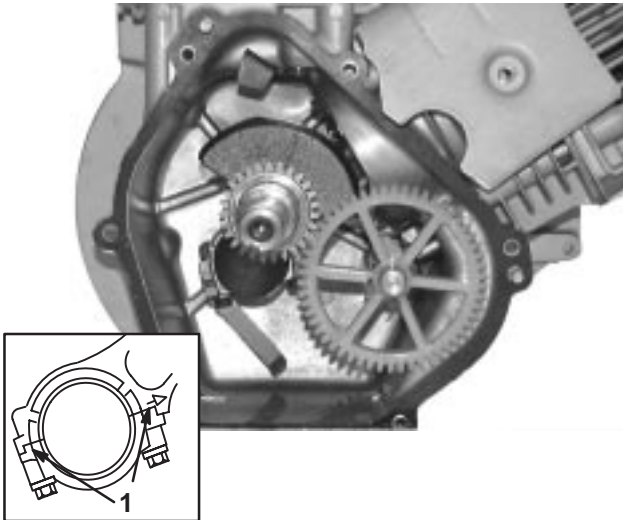

Fig. 129 – Rod and Cap Alignment

- Match marks

- Cap should snap on when assembled correctly. Install rod screws.
- Torque connecting rods screws, using Briggs & Stratton Tool #19197 or 19393, Torque Wrench to specifications listed in Table No. 5, page 52.

Note: Failure to use a torque wrench can result in loose rods causing breakage, or deformed over tightened rods causing scoring.

- Rotate crankshaft two (2) revolutions to make sure crankpin and rod are not binding during rotation.
- Move connecting rod sideways to be sure rod slides from side to side.

Specification Tables

Table No. 1
Piston Ring Groove Rejects

Compression Rings	Oil Control Ring
.007" (18mm)	.007" (18mm)

Table No. 2
Piston Ring End Gap Reject

Top Comp. Ring	Center Comp. Ring	Oil Control Ring
.020" (.51mm)	.030" (.76mm)	.035" (.89mm)

Table No. 3
Connecting Rod Rejects

Crankpin Bearing	Piston Pin Bearing
1.102" (27.98mm)	.627" (15.93mm)

Table No. 4 – Piston Pin & Piston Pin Bore Rejects

Piston Pin	Piston Pin Bore
.624" (15.85mm)	.627" (15.93mm)

Table No. 5
Connecting Rod Screw Torque

Torque In. Lbs. (Nm)
100 (11.3)

Crankshaft and Camshaft

Contents

Remove Crankshaft and Camshaft	53
Remove Crankshaft	53
Inspect Crankshaft	53
Inspect Camshaft	54
Check Compression Release	54
Install Crankshaft and Camshaft	54
Install Crankshaft	54
Install Camshaft	54
Install Crankcase Sump	54
Adjust Crankshaft End Play	55
Specification Tables	55

Remove Crankshaft and Camshaft

Before removing crankshaft from engine, remove rust, paint, or burrs from power take off end of crankshaft. This will eliminate or reduce chances of damaging oil seal and crankcase sump bearing.

1. Drain oil from crankcase.
2. Remove crankcase cover or sump.
3. If crankcase cover or sump sticks, tap lightly with soft hammer on alternate sides near dowel pins, Fig. 130.

Note: It is not necessary to remove locating pins.

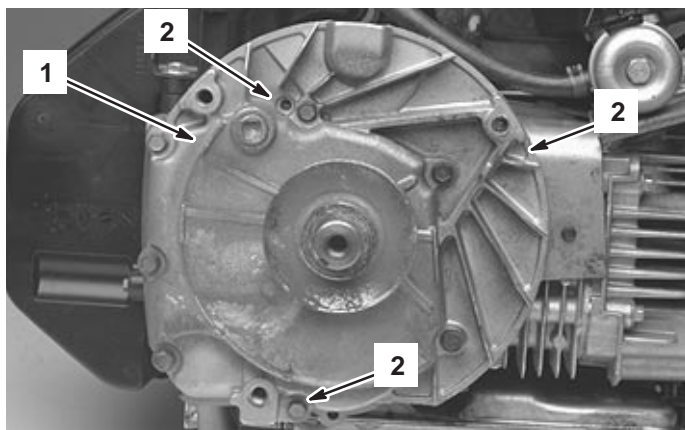

Fig. 130 – Removing Crankcase Cover

- | | |
|--------------------|--------------|
| 1. Crankcase cover | 2. Dowel pin |
|--------------------|--------------|

4. Tip engine over onto flywheel side of crankcase.
5. Support engine to prevent end of crankshaft from resting on workbench.
6. Rotate crankshaft until timing marks are aligned.

7. With camshaft in this position, the valve tappets will remain clear of cam lobes. Lift out camshaft, Fig. 131.

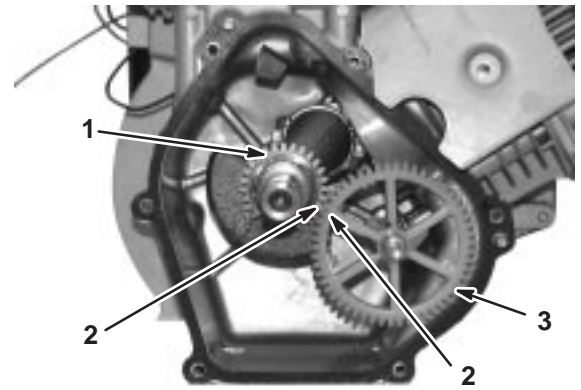

Fig. 131 – Removing Camshaft

- | | |
|----------------|-------------|
| 1. Timing gear | 3. Camshaft |
| 2. Timing mark | |

Remove Crankshaft

1. Before crankshaft can be removed, it is necessary to remove flywheel, page 15, and connecting rod cap, page 49.
2. Rotate crankshaft to position piston at top dead center for ease of removal.
3. Remove crankshaft from crankcase.

Inspect Crankshaft

Table No. 1, page 55 shows reject sizes of various wear points of the crankshaft. Discard crankshaft if worn smaller than size shown. Keyways should be checked to be sure they are not worn or spread. Remove burrs from keyway edges to prevent scratching bearing. Fig. 132 shows various points to be checked on crankshaft.

Note: Do not straighten bent crankshafts.

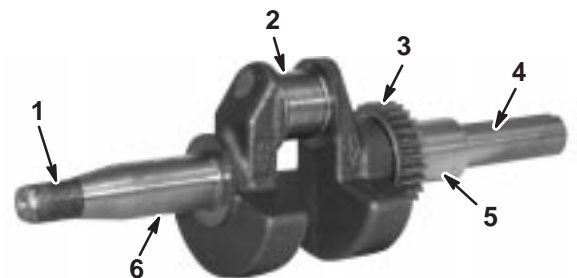

Fig. 132 – Crankshaft Check Points

- | | |
|----------------|----------------|
| 1. Threads | 4. Keyway |
| 2. Crankpin | 5. PTO journal |
| 3. Timing gear | 6. Mag journal |

Check timing gears for chipped or cracked teeth and keyway for wear. Replace timing gear, if damaged. If timing gear is chipped or cracked, also check camshaft for damage.

Inspect Camshaft

Inspect gear teeth for wear and nicks, Fig. 133. Camshaft, camshaft journals, and lobe rejection sizes are shown in Table No. 3, page 55. See Fig. 133 for other areas to be checked for wear and freedom of movement.

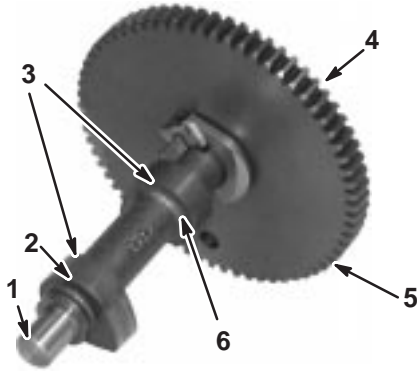

Fig. 133 – Camshaft Check Points

- | | |
|----------------|----------------|
| 1. Mag journal | 4. PTO journal |
| 2. Intake | 5. Gear teeth |
| 3. Cam lobe | 6. Exhaust |

Check Compression Release

Check compression release mechanism for wear, nicks, and freedom of movement, Fig. 134. Replace if compression release is worn or sticking.

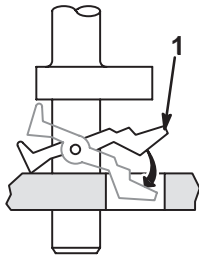

Fig. 134 – Compression Release Mechanism

1. Mechanical yoke weights

Install Crankshaft and Camshaft

Install Crankshaft

1. Install intake and exhaust valve tappets first.
2. Select Briggs & Stratton Tool #19356, Seal Protector based on size of magneto seal journal from Table No. 4, page 55.
3. Insert seal protector into magneto seal.
4. Supporting both ends of crankshaft, install in cylinder.
5. Install connecting rod on crankshaft, page 51.
6. Install slip fit timing gear (if removed) with inner chamfer toward crankpin. This assures timing mark will be visible.

Install Camshaft

Install camshaft, making sure tappets clear cam lobes. Timing marks must align, Fig. 135.

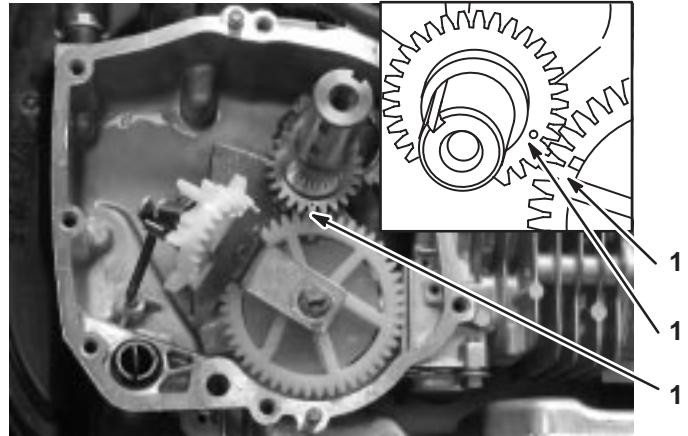

Fig. 135 – Aligning Timing Marks, Vertical Crankshaft

1. Timing mark

Install Crankcase Sump

1. Check governor shaft position, page 25, and install crankcase sump using seal protectors as listed in Table No. 4, page 55. Do not force sump.
2. Install screws and torque in sequence shown, Fig. 136.

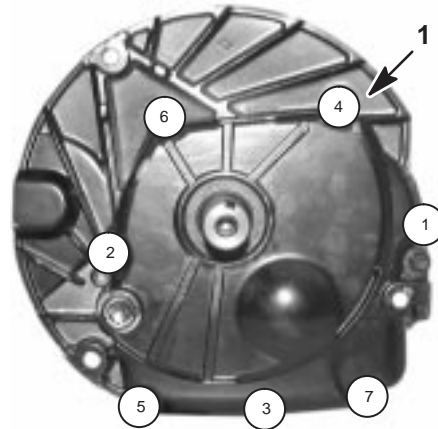

Fig. 136 – Torque Sequence

1. Sealant
3. See Table No. 5, page 55 for torque values.

Note: It may be necessary to rotate crankshaft and camshaft to get oil pump (when equipped) to engage drive slot for oil pump in camshaft.

Note: Screw assembled at position four, Fig. 136, was factory coated with sealant. If sealant is missing, coat with a non-hardening sealant such as Permatex® 2, or equivalent.

Adjust Crankshaft End Play

If end play is less than stated in Table No. 6, page 55, use additional gasket(s) to get proper end play, Fig. 137.

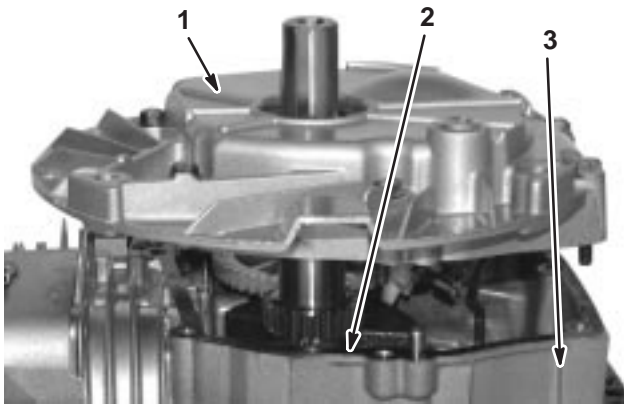

Fig. 137 – Adjusting Crankshaft End Play

1. Oil sump
2. Gaskets .015" (.38mm)
3. Cylinder

If end play with standard gasket is more than what is listed in Table No. 6, page 55, replace crankcase cover or sump.

Specification Tables

Table No. 1

Crankshaft Reject Sizes			
Mag. Journal	Crankpin Journal	PTO Journal	Eccentric
.873" (22.17mm)	1.097" (27.86mm)	1.060" (26.92mm)	–

Table No. 2

Crankshaft Grinding Dimensions for Undersize Connecting Rods		
.020" .51 mm Undersized Crankpin Size	Fillet Radius	Crankshaft Throw
$\frac{1.0783"}{1.0791"}$ (27.389mm) (27.409mm)	$\frac{.069"}{.079"}$ (1.75mm) (2.01mm)	1.020" (25.908mm)

Table No. 3

Camshaft Reject Sizes		
Mag. Journal	PTO Journal	Cam Lobes
.498" (12.65mm)	.498" (12.65mm)	Galled

Table No. 4

Seal Protectors		
Briggs & Stratton Tool #	Color	Crankshaft Journal Size
19334/5	Brown	1.062" (26.97mm)

Table No. 5

Crankcase Sump Torque
In. Lbs.
Nm
110 (12.0)

Table No. 6

Crankshaft End Play
In.
mm
.002"–.028" (.05mm–.86mm)

Cylinder and Bearings

Contents

Cylinder	56
Inspection	56
Cylinder Finish (Cross Hatch)	56
Cylinder Cleaning	56
Check Plain or DU™ Bearings	57
Check Camshaft Bearings	57
Plain or DU™ Bearings	57
Repair Worn Aluminum Bearings	57
Remove DU™ Magneto Bearing	57
Install Magneto DU™ Bushing	57
Oil Seals	58
Crankcase Sump	58
Install	58
Specification Tables	58

Cylinder

GTS 200 OHV engines use aluminum alloy plain bearings as part of the cylinder material.

Inspection

Always inspect cylinder after engine has been disassembled. Visual inspection will show if there are any cracks, stripped bolt holes, broken fins or if cylinder wall is damaged.

Use Telescoping Gauge and Dial Caliper, or inside micrometer to determine size of cylinder bore.

Measure at right angles, Fig. 138.

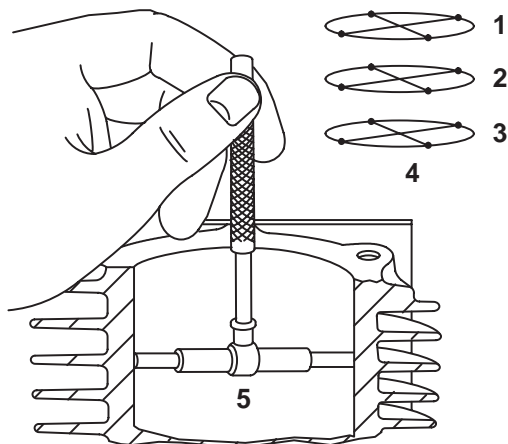

Fig. 138 – Checking Cylinder Bore

- | | |
|-----------|---------------------------------|
| 1. Top | 4. Measure at six points |
| 2. Center | 5. Center of piston ring travel |
| 3. Bottom | |

Table No. 4, page 58 lists standard cylinder bore sizes.

If the cylinder bore is more than .003” (.08mm) oversize, or .0015” (.04mm) out of round, it must be replaced.

Note: If cylinder bore is within specification and shows no sign of scoring or other damage, new piston rings may be installed providing cylinder bore is reconditioned using a rigid hone with finishing stones, to restore the proper cross hatch angle in the cylinder bore.

Note: When installing new piston rings in a cylinder bore that is within specification shown, the cylinder bore should be reconditioned. The proper cylinder cross hatch ensures proper ring lubrication and break-in. Some engine models produced at the factory have diamond bored cylinders which do not exhibit a cross hatch finish. The diamond bore cylinders are reconditioned using the same procedure as a conventional cylinder.

Cylinder Finish (Cross Hatch)

The finish on a reconditioned cylinder should have a crosshatch appearance, Fig. 139. Proper stones, lubrication and drill speed along with rapid movement of hone within the cylinder during the last few strokes, will produce this finish. Crosshatching aids proper lubrication.

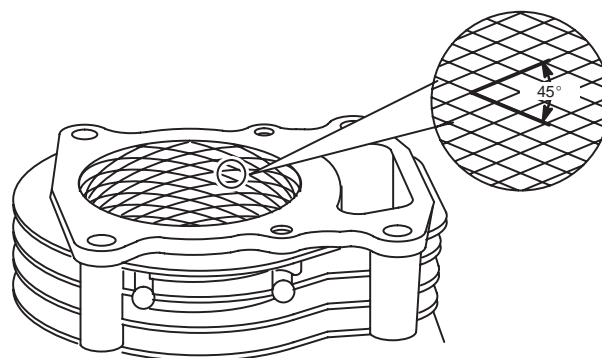

Fig. 139 – Cross Hatch

Note: To produce the proper cross hatch finish use a drill speed of approximately 200 RPM and 40-60 strokes per minute.

Lubricate hone liberally to prevent build up on finishing stones.

Note: A carpenter’s brace can also be used to produce proper crosshatch in cylinder bore.

Cylinder Cleaning

Note: It is most important that the entire cylinder and crankcase be thoroughly cleaned after honing.

Wash the cylinder and crankcase carefully in commercial parts cleaning solvent. Thoroughly wash cylinder and crankcase using a stiff brush with **soap and hot water**. Clean until all traces of honing grit are gone.

Note: Honing grit is highly abrasive and will cause rapid wear to all of the internal components of the engine unless it is completely removed.

Check Plain or DU™ Bearings

Bearings should be replaced if scored or if plug gauge will enter. Try gauge at several locations in bearing, Fig. 140.

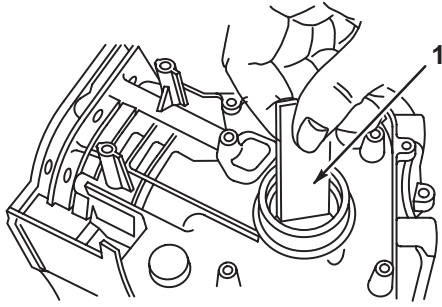

Fig. 140 – Checking Bearing

1. Plug gauge

See gauge listing in Table No. 1, page 57, Magneto Bearings, or Table No. 2, page 57, PTO Bearings.

If gauge is not available, refer to Table No. 5, page 58 for reject dimensions.

Scored or damaged DU™ magneto bearings can be replaced, Table No. 1, page 57.

Check Camshaft Bearings

Replace cylinder, crankcase cover, or sump if cam gear bearings are worn more than than shown in Table No. 6, page 58. If specified plug gauge can be inserted in bearing 1/4" (6.35mm) or more, replace cylinder, crankcase cover or sump, Fig. 141. If gauge is not available, and bearings are worn larger than dimensions shown in Table No. 6, replace cylinder, crankcase cover or sump.

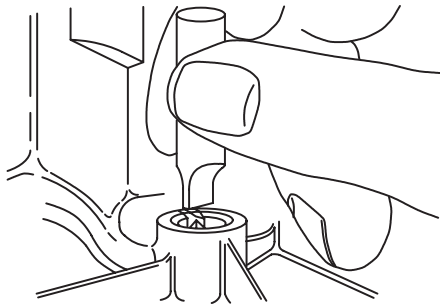

Fig. 141 – Checking Camshaft Bearing

Plain or DU™ Bearings

Repair Worn Aluminum Bearings

Select tools needed to repair magneto bearing from Table No. 1. Remove and discard oil seal for bearing to be repaired. Place pilot guide bushing in bearing opposite of bearing to be repaired. Have flange of bushing on inside of crankcase. Replace sump if sump crankshaft bearing is worn or damaged.

Table No. 1

Magneto Bearing Repair Tool Chart Briggs & Stratton Tools		
Cylinder Support	Bushing Driver	Plug Gauge
19123	19124	19166

Table No. 2

PTO Bearing Repair Tool Chart		
Cylinder Support	Bushing Driver	Plug Gauge
N/A	N/A	19375

Remove DU™ Magneto Bearing

1. Refer to Table No. 1, page 57, for tools required to remove DU™ bearings.
2. Place cylinder support under magneto bearing and place bushing driver down through worn bearing.
3. Press bearing out of cylinder, Fig. 142.

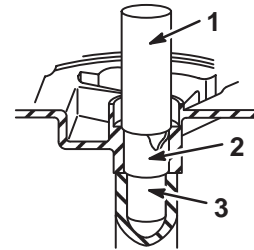

Fig. 142 – Removing Bearing

1. Bushing driver bearing
2. Bearing
3. Cylinder support

Install Magneto DU™ Bushing

1. Place DU bearing on cylinder or cover bearing with oil hole in line with oil hole in cylinder or cover bearing. If cover bearing does not have oil hole, place split (when present) of bearing as shown in Fig. 143.



Fig. 143 – Locating and Staking Bearing

1. Split in bearing

2. Press bearing to dimension shown in Table No. 7, page 58 and Fig. 144.

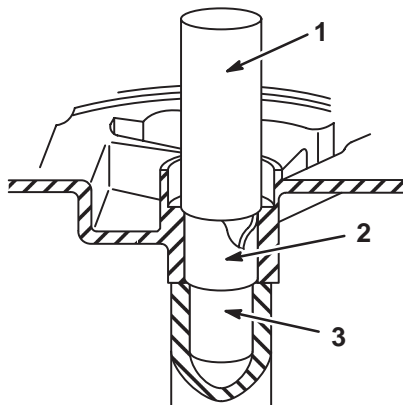

Fig. 144 – Pressing Bearing

1. Bushing driver bearing
2. Bearing
3. Cylinder support

3. Stake bearing as shown, Figs. 143 and 145.

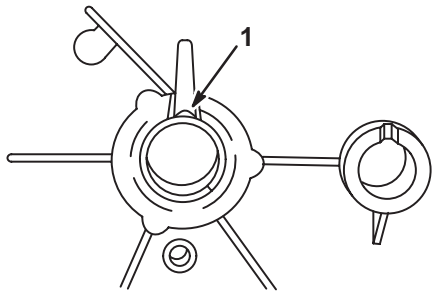

Fig. 145 – Staking Bearing

1. Staked

Oil Seals

Always install new oil seals whenever engine is disassembled for major servicing or when replacing bearings. When installing crankcase cover or sump, always use the correct seal protector to prevent damaging oil seal, Table No. 3.

Crankcase Sump

Install

Use Briggs & Stratton Tool #19356, Seal Protector Kit, Table No. 3, to protect oil seal when installing crankcase cover or sump. Do not force cover or sump. Make sure mechanical governor gear and oil pump (when used) is engaged with cam gear.

1. For adjustment procedure for crankshaft end play see Crankshaft and Camshaft, page 55.
2. Torque crankcase cover screws in sequence shown in Fig. 146.

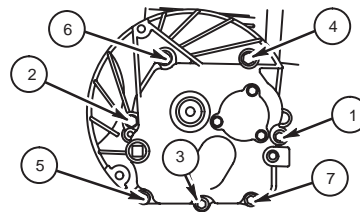

Fig. 146 – Torque Sequence

Specification Tables

Table No. 3

Seal Protectors		
Briggs & Stratton Tool #	Color	Crankshaft Journal Size
19334/5	Brown	1.062" (26.97mm)

Table No. 4

Standard Bore Diameter	
Maximum Inches	Minimum Inches
2.6885" (68.288mm)	2.6875" (68.263mm)

Table No. 5

Cylinder Bearing Reject Size Chart	
Magneto Bearing	PTO Bearing
.878" (22.30mm)	1.065" (27.05mm)

Table No. 6

Camshaft Bearing Reject Sizes	
Inches Millimeters	Gauge #
.504" (12.80mm)	19164

Table No. 7

DU™ Bearing Depth	
Depth Mag.	Depth PTO
.080" (2.03mm)	—

Table No. 8

Crankcase Sump Torque	
In. Lbs.	Nm
110	(12.0)

Muffler

Contents

Remove Exhaust System	59
Inspect Exhaust System	59
Install Muffler	60
Install Muffler Guard	60

Remove Exhaust System

1. Remove air filter cover, static guard, and fuel tank, Fig. 147.

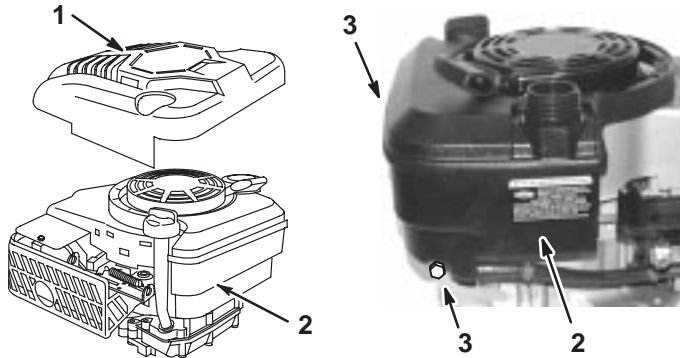

Fig. 147 – Removing Static Guard and Fuel Tank

- | | |
|-----------------|----------|
| 1. Static guard | 3. Screw |
| 2. Fuel tank | |

2. Remove three (3) screws holding muffler guard and remove guard, Fig. 148.

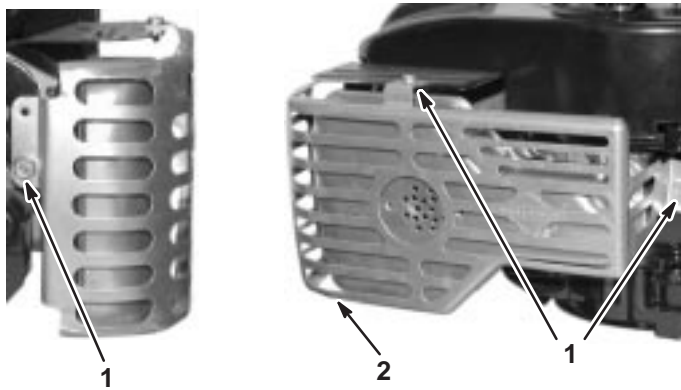

Fig. 148 – Removing Muffler Guard and Muffler

- | | |
|----------|------------------|
| 1. Screw | 2. Muffler guard |
|----------|------------------|

3. Remove dipstick and oil fill tube.
4. Remove blower housing and rewind starter, Fig. 149.

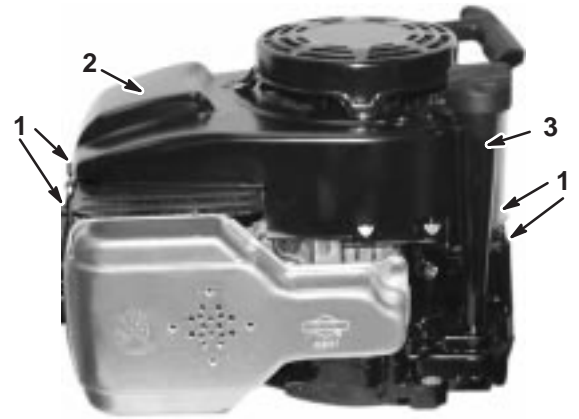

Fig. 149 – Removing Dipstick and Oil Fill Tube, Blower Housing and Rewind Starter

- | | |
|--------------------------------------|-------------------------------|
| 1. Screws (4) | 3. Dipstick and oil fill tube |
| 2. Blower housing and rewind starter | |

5. Remove two screws holding exhaust pipe flange to cylinder head, one (1) screw holding muffler bracket to cylinder head, and one (1) screw holding muffler to cylinder and remove muffler assembly, Fig. 150.
6. Remove old muffler gasket from cylinder head.

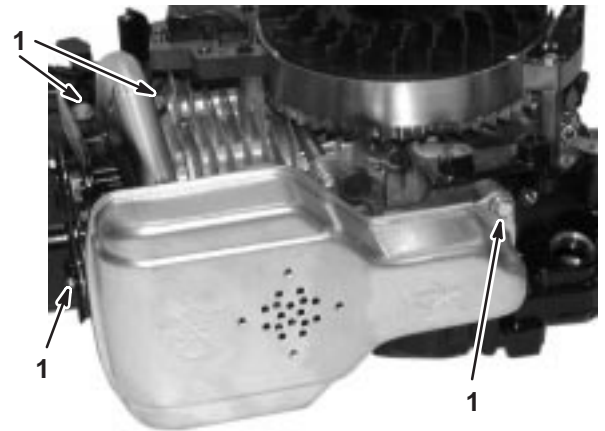

Fig. 150 – Removing Muffler

- | |
|----------|
| 1. Screw |
|----------|

Inspect Exhaust System

Check muffler mounting bracket and/or muffler adapters for cracked welds or breakage. Check muffler for split seams, loose internal parts, or cracked welds. Replace any damaged parts with new Original Equipment Parts.

Install Muffler

1. Coat muffler mounting screws with Valve Guide Lubricant, Briggs & Stratton Part #93963.
2. Place new exhaust gasket on cylinder head and place muffler flange on gasket.
3. Install two screws in muffler flange and torque to 85 in. lbs. (10.0Nm), Fig. 151.

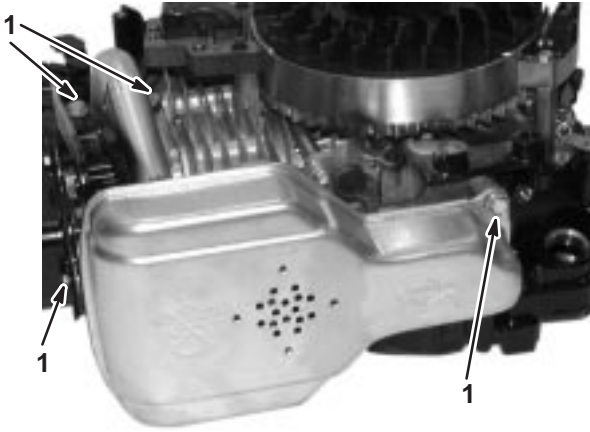

Fig. 151 – Installing Muffler

1. Screw: torque to 85 in. lbs (10.0Nm)
-
4. Install screw in muffler bracket to cylinder head and torque to 85 in. lbs. (10.0Nm), Fig. 151.
 5. Install screw in muffler to cylinder bracket and torque to 85 in. lbs. (10.0Nm).

Install Muffler Guard

1. Lightly coat muffler guard mounting screws with Valve Guide Lubricant, Briggs & Stratton Part #93963.
2. Place muffler guard over muffler and torque muffler guard to bracket screw to 85 in. lbs. (10.0Nm), Fig. 148.
3. Torque muffler guard to cylinder screw to 50 in. lbs. (6.0Nm).
4. Torque muffler guard to blower housing screw to 15 – 20 in. lbs. (2Nm).
5. Install blower housing as described in Rewind Starter, Page 37.
6. Install dipstick tube and dipstick.
7. Install fuel tank and static guard.