



Count on it.

Operator's Manual

Pro Force® Debris Blower

Model No. 44554—Serial No. 405800000 and Up



This product complies with all relevant European directives; for details, please see the separate product specific Declaration of Conformity (DOC) sheet.

It is a violation of California Public Resource Code Section 4442 or 4443 to use or operate the engine on any forest-covered, brush-covered, or grass-covered land unless the engine is equipped with a spark arrester, as defined in Section 4442, maintained in effective working order or the engine is constructed, equipped, and maintained for the prevention of fire.

The enclosed engine owner's manual is supplied for information regarding the US Environmental Protection Agency (EPA) and the California Emission Control Regulation of emission systems, maintenance, and warranty. Replacements may be ordered through the engine manufacturer.

The DOT tire information is located on the side of each tire. This information gives load and speed ratings. Replacement tires should have the same or better ratings. Ensure that the tires meet or exceed the weight requirements of your machine.

Electromagnetic Compatibility

Domestic: This device complies with FCC Rules Part 15. Operation is subject to the following two conditions: (1) This device may not cause harmful interference and (2) this device must accept any interference that may be received, including interference that may cause undesirable operation.

This equipment generates and uses radio frequency energy and if not installed and used properly, in strict accordance with the manufacturer's instructions, may cause interference to radio and television reception. It has been type tested and found to comply within the limits of a FCC Class B computing device in accordance with the specifications in Subpart J of Part 15 of FCC Rules, as stated above. However, there is no guarantee that interference will not occur in a particular installation. If this equipment does cause interference to radio or television reception, which can be determined by turning the equipment off and on, the user is encouraged to try to correct the interference by one or more of the following measures: Reorient the receiving antenna, relocate the remote control receiver with respect to the radio/TV antenna or plug the controller into a different outlet so that the controller and radio/TV are on different branch circuits. If necessary, the user should consult the dealer or an experienced radio/television technician for additional suggestions. The user may find the following booklet prepared by the Federal Communications Commission helpful: "How to Identify and Resolve Radio-TV Interference Problems". This booklet is available from the U.S. Government Printing Office, Washington, DC 20402. Stock No. 004-000-00345-4.

**FCC ID: W7OMRF24J40MDME-Base,
OA3MRF24J40MA-Hand Held**

IC: 7693A-24J40MDME-Base, 7693A-24J40MA-Hand Held

Operation is subject to the following two conditions: (1) this device may not cause interference, and (2) this device must accept any interference, including interference that may cause undesired operation of the device.

Japan Electromagnetic Compatibility Certification

Handheld:  R 204-520022

RF2CAN:  R 204-520297

Mexico Electromagnetic Compatibility Certification

Handheld: IFTEL : RCPMIMR15-2209

RF2CAN: IFTEL : RCPMIMR15-0142

Korea Electromagnetic Compatibility Certification(Decal provided in separate kit)

Handheld:  MSIP-CRM-TZQ-SMHH
해당 무선설비는 전파혼신 가능성이 있으므로 인명안전과 관련된 서비스는 할 수 없음

RF2CAN:  MSIP-CRM-TZQ-MRF-E
MSIP-CRM-TZQ-RF2CAN
해당 무선설비는 전파혼신 가능성이 있으므로 인명안전과 관련된 서비스는 할 수 없음

Singapore Electromagnetic Compatibility Certification

Handheld: TWM240007_IDA_N4021-15

RF2CAN: TWM-240005_IDA_N4024-15

Morocco Electromagnetic Compatibility Certification

AGREE PAR L'ANRT MAROC

Numero d'agrement: MR 14092 ANRT 2017

Delivre d'agrement: 29/05/2017

Important: Changing or modifying the machine without the express approval from the party responsible for compliance could void your authority to operate the equipment.

Do not change or modify the machine without the express approval from the party responsible for compliance.

⚠ WARNING

CALIFORNIA Proposition 65 Warning

The engine exhaust from this product contains chemicals known to the State of California to cause cancer, birth defects, or other reproductive harm.

Battery posts, terminals, and related accessories contain lead and lead compounds, chemicals known to the State of California to cause cancer and reproductive harm. Wash hands after handling.

Use of this product may cause exposure to chemicals known to the State of California to cause cancer, birth defects, or other reproductive harm.

Important: With your mobile device, you can scan the QR code on the serial number (if equipped) to access warranty, parts, and other product information.

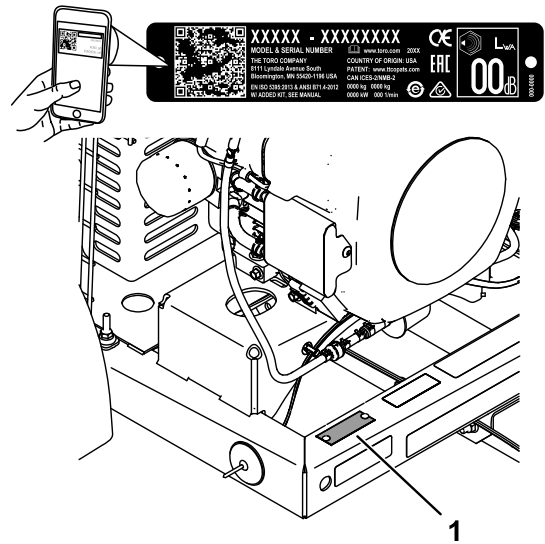

Figure 1

g257159

1. Model and serial number location

Introduction

The debris blower is towed behind a ride-on machine which is intended to be used by professional, hired operators in commercial applications. It is primarily designed to use wind power to quickly clear large areas of unwanted debris on well-maintained lawns in parks, golf courses, sports fields, and on commercial grounds. Using this product for purposes other than its intended use could prove dangerous to you and bystanders.

Important: To maximize the safety, performance, and proper operation of this machine, carefully read and fully understand the contents of this *Operator's Manual*. Failing to follow these operating instructions or to receive proper training may result in injury. For more information on safe operating practices, including safety tips and training materials, go to www.Toro.com.

Visit www.Toro.com for product safety and operation training materials, accessory information, help finding a dealer, or to register your product.

Whenever you need service, genuine Toro parts, or additional information, contact an Authorized Service Dealer or Toro Customer Service and have the model and serial numbers of your product ready. Figure 1 identifies the location of the model and serial numbers on the product. Write the numbers in the space provided.

Model No. _____
Serial No. _____

This manual identifies potential hazards and has safety messages identified by the safety-alert symbol (Figure 2), which signals a hazard that may cause serious injury or death if you do not follow the recommended precautions.



Figure 2

Safety-alert symbol

g000502

This manual uses 2 words to highlight information. **Important** calls attention to special mechanical information and **Note** emphasizes general information worthy of special attention.

Contents

Safety	4
General Safety	4
Safety and Instructional Decals	5
Setup	7
1 Connecting the Battery	8
2 Mounting the Hitch to the Debris Blower	8
3 Connecting the Debris Blower to the Tow Vehicle	8
Product Overview	10
Controls	10
Before Operation	11
Before Operation Safety	11
Adding Fuel	11
Checking the Engine-Oil Level	12
Checking the Tire Pressure	12
Checking the Torque of the Wheel Lug Nuts	12
During Operation	13
During Operation Safety	13
Starting the Engine	14
Stopping the Engine	14
Adjusting the Nozzle Direction	15
Using the Chute Position Indicator	15
Operating Tips	15
After Operation	16
After Operation Safety	16
Hauling	16
Maintenance	17
Maintenance Safety	17
Recommended Maintenance Schedule(s)	18
Daily Maintenance Checklist	18
Engine Maintenance	19
Engine Safety	19
Servicing the Air Cleaner	19
Servicing the Carbon Canister	20
Servicing the Engine Oil	20
Servicing the Spark Plugs	22
Cleaning the Engine Screen and the Oil Cooler	23
Fuel System Maintenance	23
Replacing the Fuel Filter	23
Servicing the Fuel Tank	24
Electrical System Maintenance	24
Electrical System Safety	24
Replacing the Fuses	25
Drive System Maintenance	25
Inspecting the Tires	25
Belt Maintenance	26
Adjusting the Belt	26
Miscellaneous Maintenance	26
Checking the Nozzle	26
Storage	27
Storage	27
Waste Disposal	28

Safety

This machine has been designed in accordance with ANSI standard B71.4-2017.

General Safety

This product is capable of throwing objects. Always follow all safety instructions to avoid serious personal injury.

- Read and understand the contents of both this *Operator's Manual* and the operator's manual of the traction unit before using this machine. Ensure that everyone using this product knows how to use this machine and the traction unit and understands the warnings.
- Use your full attention while operating the machine. Do not engage in any activity that causes distractions; otherwise, injury or property damage may occur.
- Do not put your hands or feet near moving components of the machine.
- Do not operate the machine without all guards and other safety protective devices in place and working on the machine.
- Keep children, bystanders, and pets out of the operating area. Never allow children to operate the machine.
- Always shut off the engine, remove the key (if equipped), wait for all moving parts to stop, and allow the machine to cool before adjusting, repairing, cleaning, or storing the machine.

Improperly using or maintaining this machine can result in injury. To reduce the potential for injury, comply with these safety instructions and always pay attention to the safety-alert symbol ([Figure 2](#)), which means Caution, Warning, or Danger—personal safety instruction. Failure to comply with these instructions may result in personal injury or death.

Safety and Instructional Decals



Safety decals and instructions are easily visible to the operator and are located near any area of potential danger. Replace any decal that is damaged or missing.



115-5105

decal115-5105

1. Warning—read the *Operator's Manual*.
2. Warning—all operators should read the *Operator's Manual* and be trained before operating the machine.
3. Warning—shut off the engine, remove the key, and read the *Operator's Manual* before performing maintenance.
4. Thrown object hazard—keep bystanders away.
5. Warning—stay away from moving parts; keep all guards and shields in place.
6. Warning—do not start the engine when the machine is disconnected from the tow vehicle; hitch the machine to the tow vehicle before starting the engine.

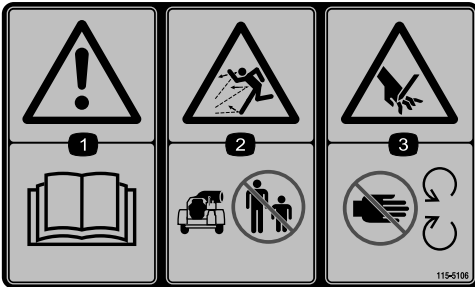

115-5106

decal115-5106

1. Warning—read the *Operator's Manual*.
2. Thrown object hazard—keep bystanders away.
3. Cutting/dismemberment hazard; hand—stay away from moving parts.

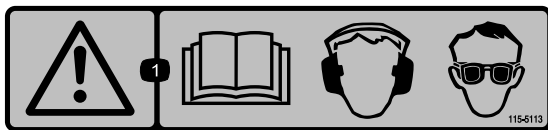

115-5113

decal115-5113

1. Warning—read the *Operator's Manual*; wear hearing and eye protection.

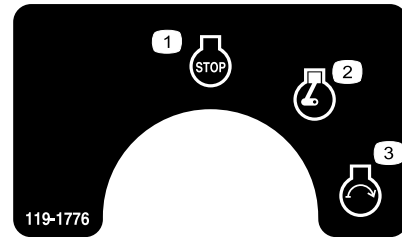

119-1776

decal119-1776

1. Engine—stop
2. Engine—run
3. Engine—start

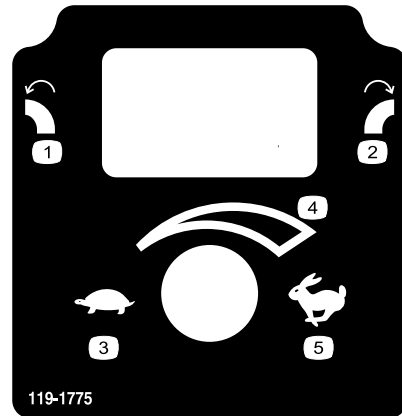

119-1775

decal119-1775

1. Rotate nozzle left
2. Rotate nozzle right
3. Slow
4. Variable speed
5. Fast

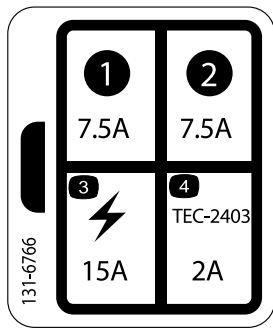

decal131-6766

131-6766

- 1. 7.5 A
- 2. 7.5 A
- 3. Electrical accessory (15 A)
- 4. TEC-2403 (2 A)

⚠ WARNING: Cancer and Reproductive Harm - www.P65Warnings.ca.gov.
For more information, please visit www.tccoCProp65.com
CALIFORNIA SPARK ARRESTER WARNING
Operation of this equipment may create sparks that can start fires around dry vegetation. A spark arrester may be required. The operator should contact local fire agencies for laws or regulations relating to fire prevention requirements.

133-8062

decal133-8062

133-8062

Setup

Loose Parts

Use the chart below to verify that all parts have been shipped.

Procedure	Description	Qty.	Use
1	Grafo 112X grease (Toro Part No. 505-47)	—	Connect the battery.
2	Debris blower assembly Hitch Bolt (3/8 x 3 inches) Flange nut (3/8 inch) Hitch clevis Bolt (5/8 x 4-1/2 inch) Locknut (5/8 inch)	1 1 2 2 1 2 2	Mount the hitch to the debris blower.
3	Hitch pin Clevis	1 1	Connect the blower to the tow vehicle.

Media and Additional Parts

Description	Qty.	Use
Operator's Manual	1	Read before operating.
Engine owner's manual	1	Use to reference engine operation and maintenance.
Declaration of Conformity	1	For CE compliance.

Note: Determine the left and right sides of the machine from the normal operating position.

1

Connecting the Battery

Parts needed for this procedure:

—	Grafo 112X grease (Toro Part No. 505-47)
---	--

Procedure

1. Remove the clips securing the battery cover to the battery box (Figure 3).

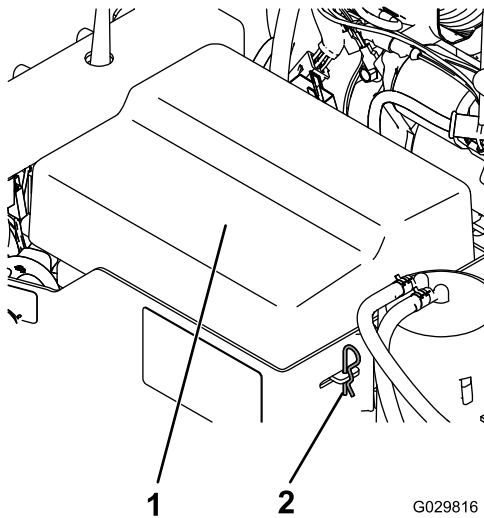

Figure 3

1. Battery cover
2. Battery clip

⚠ DANGER

Battery electrolyte contains sulfuric acid, which is fatal if consumed and causes severe burns.

- Do not drink electrolyte and avoid contact with skin, eyes or clothing. Wear safety glasses to shield your eyes and rubber gloves to protect your hands.
- Fill the battery where clean water is always available for flushing the skin.

2. Attach the positive cable (red cable) to the positive (+) terminal.
3. Attach the negative cable (black cable) to the negative (-) terminal of the battery.
4. Coat the terminals and mounting fasteners with Grafo 112X (skin over) grease (Toro Part No. 505-47) to prevent corrosion.

5. Install the battery cover and secure with the clips.

2

Mounting the Hitch to the Debris Blower

Parts needed for this procedure:

1	Debris blower assembly
1	Hitch
2	Bolt (3/8 x 3 inches)
2	Flange nut (3/8 inch)
1	Hitch clevis
2	Bolt (5/8 x 4-1/2 inch)
2	Locknut (5/8 inch)

Procedure

1. Position the debris blower on a flat, level surface.
2. Insert the hitch tube into the frame brackets (Figure 4). Secure the tube to the frame with 2 bolts (3/8 x 3 inches) and flange nuts (3/8 inch) and torque to 40 N·m (30 ft-lb).

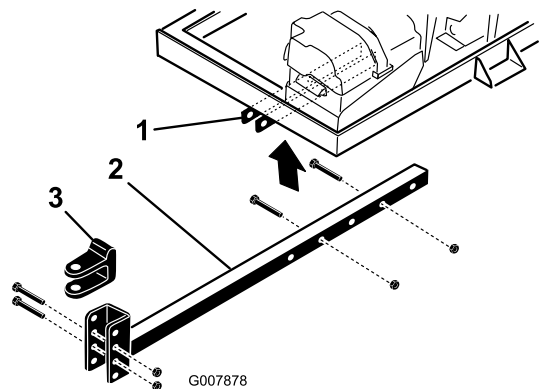

Figure 4

1. Frame brackets
2. Hitch tube
3. Hitch clevis

Note: The hitch tube can be rotated 180 degrees to accommodate different hitch heights.

3

Connecting the Debris Blower to the Tow Vehicle

Parts needed for this procedure:

1	Hitch pin
1	Clevis

Procedure

1. Back the tow vehicle up to the blower.
2. Adjust the blower hitch clevis to the same level as the tow vehicle hitch as follows:
 - Set the hitch tube on a jack stand to keep it parallel to the ground.
 - Remove the bolts and locknuts securing the hitch clevis (Figure 4) to the hitch tube.
 - Raise or lower the hitch clevis to the position approximately level with the tow vehicle hitch.
 - Secure the clevis to the hitch with the bolts and locknuts previously removed and torque to 203 N·m (150 ft-lb). Ensure that the debris blower frame is parallel with the ground.
3. Adjust the hitch tube length to assure the blower does not contact the tow vehicle when turning as follows:
 - Remove the bolts and nuts securing the hitch tube to the frame brackets (Figure 4).
 - Secure the tube to the frame with the bolts and flange nuts.
4. Connect the blower clevis hitch to the tow vehicle hitch with the hitch pin and clevis (Figure 5).

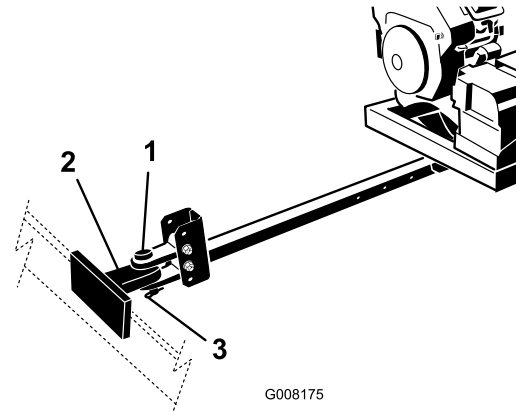

Figure 5

1. Hitch pin
2. Tow vehicle hitch
3. Clevis

g008175

Product Overview

Controls

Nozzle-Direction Button

Press the button to rotate the nozzle to the desired direction (Figure 6).

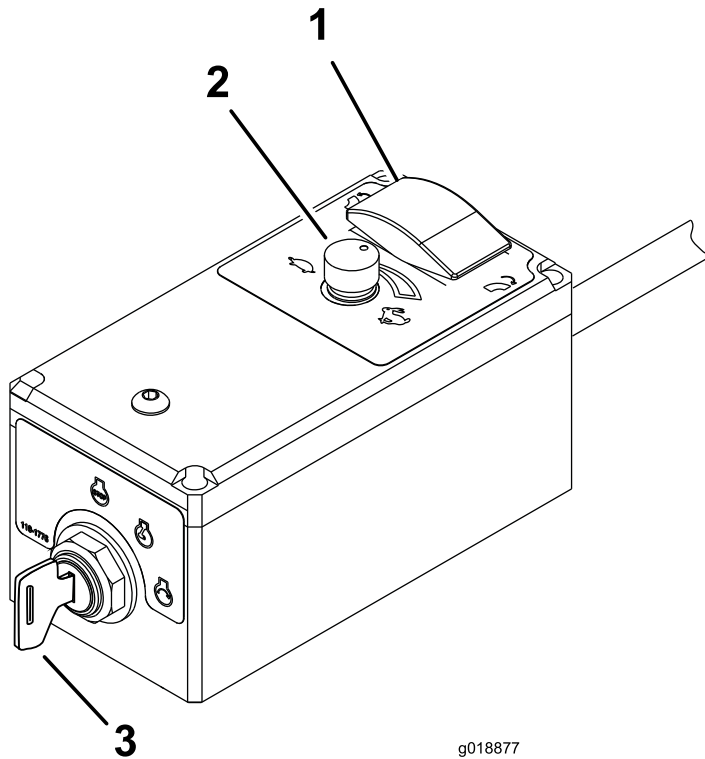

Figure 6

1. NOZZLE-DIRECTION button
2. Throttle/Engine speed
3. Ignition switch

Choke Control

To start a cold engine, move the choke control lever (Figure 7) to the ON position.

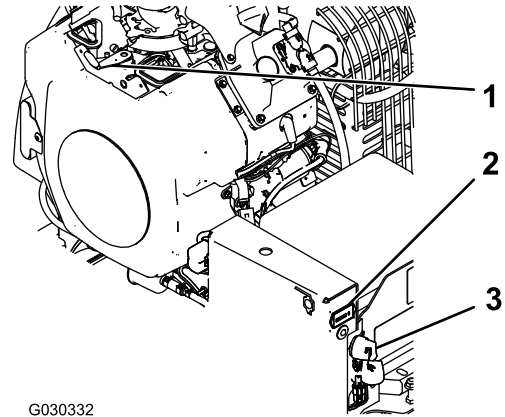

Figure 7

1. Choke control
2. Hour meter
3. Ignition switch

Hour Meter

The hour meter (Figure 7) indicates the total hours of machine operation.

Throttle/Engine Speed

Rotate the knob to FAST (rabbit) or SLOW (turtle) to increase or decrease the speed of the engine (Figure 6).

Remote Ignition Switch

The ignition switch which is used to start and shut off the engine, has three positions: OFF, RUN, and START. Rotate the key clockwise to the START position to engage the starter motor. Release the key when the engine starts. The key moves automatically to the RUN position. To shut engine off, rotate the key counterclockwise to the OFF position (Figure 6).

Operation

Note: Determine the left and right sides of the machine from the normal operating position.

Before Operation

Before Operation Safety

General Safety

- Never allow children or untrained people to operate or service the machine. Local regulations may restrict the age of the operator. The owner is responsible for training all operators and mechanics.
- Become familiar with the safe operation of the equipment, operator controls, and safety signs.
- Always shut off the engine, remove the key, wait for all moving parts to stop, and allow the machine to cool before adjusting, repairing, cleaning, or storing the machine. Know how to stop the machine and shut off the engine quickly.
- Keep all guards, safety devices, and decals in place. Repair or replace all safety devices and replace all illegible or missing decals. Do not operate the machine unless they are present and functioning properly.
- Ensure that the traction unit is suitable for use with an implement of this weight by checking with the traction unit supplier or manufacturer.
- Do not modify this equipment in any manner.

Fuel Safety

- Use extreme care in handling fuel. It is flammable and its vapors are explosive.
- Extinguish all cigarettes, cigars, pipes, and other sources of ignition.
- Use only an approved fuel container.
- Do not remove the fuel cap or fill the fuel tank while the engine is running or hot.
- Do not add or drain fuel in an enclosed space.
- Do not store the machine or fuel container where there is an open flame, spark, or pilot light, such as on a water heater or other appliance.
- If you spill fuel, do not attempt to start the engine; avoid creating any source of ignition until the fuel vapors have dissipated.

Adding Fuel

- **Fuel tank capacity:** 18.9 L (5 US gallons)
- **Recommended Fuel**
 - For best results, use only clean, fresh (less than 30 days old), unleaded fuel with an octane rating of 87 or higher ((R+M)/2 rating method).
 - Ethanol: Fuel with up to 10% ethanol (gasohol) or 15% MTBE (methyl tertiary butyl ether) by volume is acceptable. Ethanol and MTBE are not the same. Fuel with 15% ethanol (E15) by volume is not approved for use. Never use fuel that contains more than 10% ethanol by volume, such as E15 (contains 15% ethanol), E20 (contains 20% ethanol), or E85 (contains up to 85% ethanol). Using unapproved fuel may cause performance problems and/or engine damage which may not be covered under warranty.
 - Do not use fuel containing methanol.
 - Do not store fuel either in the fuel tank or fuel containers over the winter unless a fuel stabilizer is used.
 - Do not add oil to fuel.

Important: Do not use fuel additives other than a fuel stabilizer/conditioner. Do not use fuel stabilizers with an alcohol base, such as ethanol, methanol, or isopropanol.

Using Stabilizer/Conditioner

Use a fuel stabilizer/conditioner in the machine to provide the following benefits:

- Keeps fuel fresh during storage of 90 days or less. For longer storage it is recommended that the fuel tank be drained.
- Cleans the engine while it runs
- Eliminates gum-like varnish buildup in the fuel system, which causes hard starting

Important: Do not use fuel additives containing methanol or ethanol.

Add the correct amount of fuel stabilizer/conditioner to the fuel.

Note: A fuel stabilizer/conditioner is most effective when mixed with fresh fuel. To minimize the chance of varnish deposits in the fuel system, use fuel stabilizer at all times.

Filling the Fuel Tank

1. Shut off the engine.
2. Clean the area around the fuel tank cap and remove the cap (Figure 8).

Note: The fuel tank cap contains a gauge which shows the fuel level.

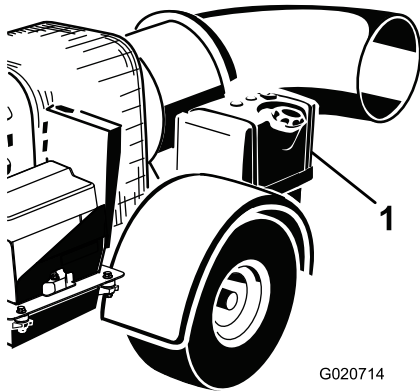

Figure 8

1. Fuel tank

3. Add fuel to the fuel tank until the level is 6 mm to 13 mm (1/4 to 1/2 inch) below the bottom of the filler neck.

Note: This space in the tank allows fuel to expand. Do not fill the fuel tanks completely full.

4. Install fuel tank cap securely.
5. Wipe up any spilled fuel.

Checking the Engine-Oil Level

Before you start the engine and use the machine, check the oil level in the engine crankcase; refer to [Checking the Engine Oil Level \(page 21\)](#).

Checking the Tire Pressure

Check the tire pressure (Figure 9).

The correct tire pressure is 96.5 kPa (14 psi).

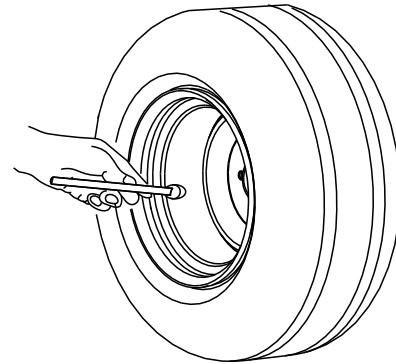

G001055

Figure 9

g001055

Checking the Torque of the Wheel Lug Nuts

Service Interval: After the first 10 hours

Check the torque of the wheel lug nuts initially and after the first 10 hours of operation.

⚠ WARNING

Failure to maintain proper torque could result in failure or loss of wheel and could result in personal injury.

Torque wheel lug nuts to 95 to 122 N·m (70 to 90 ft-lb).

During Operation

During Operation Safety

General Safety

- The owner/operator can prevent and is responsible for accidents that may cause personal injury or property damage.
- Wear appropriate clothing, including eye protection; long pants; substantial, slip-resistant footwear; and hearing protection. Tie back long hair and do not wear loose jewelry.
- Do not operate the machine while ill, tired, or under the influence of alcohol or drugs.
- Use your full attention while operating the machine. Do not engage in any activity that causes distractions; otherwise, injury or property damage may occur.
- Discharged air has considerable force and could cause injury or loss of footing. Stay away from the blower nozzle when the machine is operating.
- Keep all bystanders away; shut off the machine when bystanders enter the area, do not direct discharge toward them.
- Do not operate the machine when it is not connected to a towing vehicle.
- Do not run the engine in or direct the blower nozzle into a confined area without adequate ventilation. Engine exhaust contains carbon monoxide, an odorless gas that is fatal if inhaled.
- Do not carry passengers on the machine and keep bystanders and pets away from the machine during operation.
- Operate the machine only in good visibility to avoid holes or hidden hazards.
- Look behind and down before backing up to be sure of a clear path.
- Use care when approaching blind corners, shrubs, trees, or other objects that may obscure your vision.
- Never run an engine in an area where exhaust gasses are enclosed.
- Never leave a running machine unattended.
- When transporting the machine on public roads, follow all traffic regulations and use any additional accessories that may be required by law, such as lights, turn signals, slow-moving vehicle (SMV) signs, and others as required.
- If the machine ever vibrates abnormally, stop the machine immediately, shut off the engine, remove

the key, wait for all moving parts to stop, and inspect for damage. Repair all damage to the machine before resuming operation.

- Reduce speed when operating on rough, uneven terrain, and near curbs, holes, and other sudden changes in terrain.
- To avoid causing the machine to tip over, be careful when turning and avoid unsafe maneuvers.

Slope Safety

- Slopes are a major factor related to loss of control and rollover accidents, which can result in severe injury or death. You are responsible for safe slope operation. Operating the machine on any slope requires extra caution.
- Review the traction unit specifications to ensure that you do not exceed its slope capabilities.
- Evaluate the site conditions to determine if the slope is safe for machine operation, including surveying the site. Always use common sense and good judgment when performing this survey.
- Review the slope instructions, listed below, for operating the machine on slopes. Before you operate the machine, review the site conditions to determine whether you can operate the machine in the conditions on that day and at that site. Changes in the terrain can result in a change in slope operation for the machine.
 - Avoid starting, stopping, or turning the machine on slopes. Avoid making sudden changes in speed or direction. Make turns slowly and gradually.
 - Do not operate a machine under any conditions where traction, steering, or stability is in question.
 - Remove or mark obstructions such as ditches, holes, ruts, bumps, rocks, or other hidden hazards. Tall grass can hide obstructions. Uneven terrain could overturn the machine.
 - Be aware that operating the machine on wet grass, across slopes, or downhill may cause the machine to lose traction.
 - Use extreme caution when operating the machine near drop-offs, ditches, embankments, water hazards, or other hazards. The machine could suddenly roll over if a wheel goes over the edge or the edge caves in. Establish a safety area between the machine and any hazard.

Starting the Engine

⚠ WARNING

Rotating parts can cause serious personal injury.

- Keep hands and feet away from the machine when it is running.
- Keep hands, feet, hair, and clothing away from all moving parts to prevent injury.
- Never operate the machine with covers, shrouds, or guards removed.

1. Ensure that the blower is attached to the tow vehicle before you start the blower.
2. Move the choke control to the ON position before starting a cold engine.

Note: A warm or hot engine may **not** require choking. After the engine starts, move the choke control to the OFF position.

3. Rotate the engine ignition key clockwise to the START position to start the engine; release the key when the engine starts (Figure 10).

Note: If the key was left in the RUN position for an extended time, move the key to the OFF position before proceeding to the starting procedure.

Important: Do not engage starter for more than 10 seconds at a time. If engine fails to start allow 10 second cool-down period between attempts. Failure to follow these instructions can burn out starter motor.

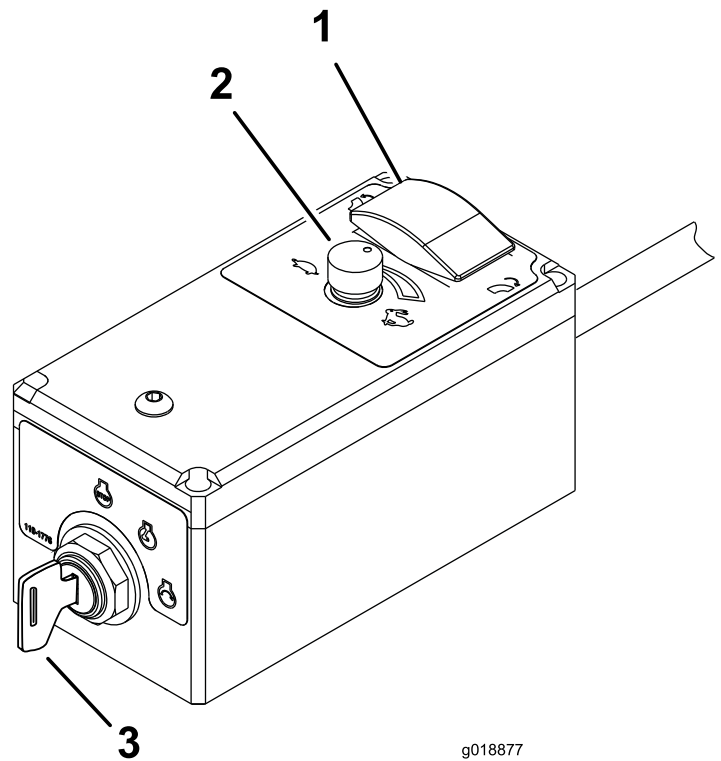

g018877

g018877

Figure 10

1. NOZZLE DIRECTION button
2. Throttle/Engine speed
3. Ignition switch

4. After the engine starts, move the choke control to the OFF position. If the engine stalls or hesitates, move the choke back to the RUN position for a few seconds, then set the engine speed to the desired setting. Repeat this as required.

Stopping the Engine

1. Decrease the engine speed to 3/4 throttle.
2. Rotate the remote ignition key to the OFF position.
3. If leaving the machine, rotate the engine key to the OFF position and remove it from the switch (Figure 10).

Adjusting the Nozzle Direction

Press the nozzle direction button to rotate the nozzle to the desired direction (Figure 11).

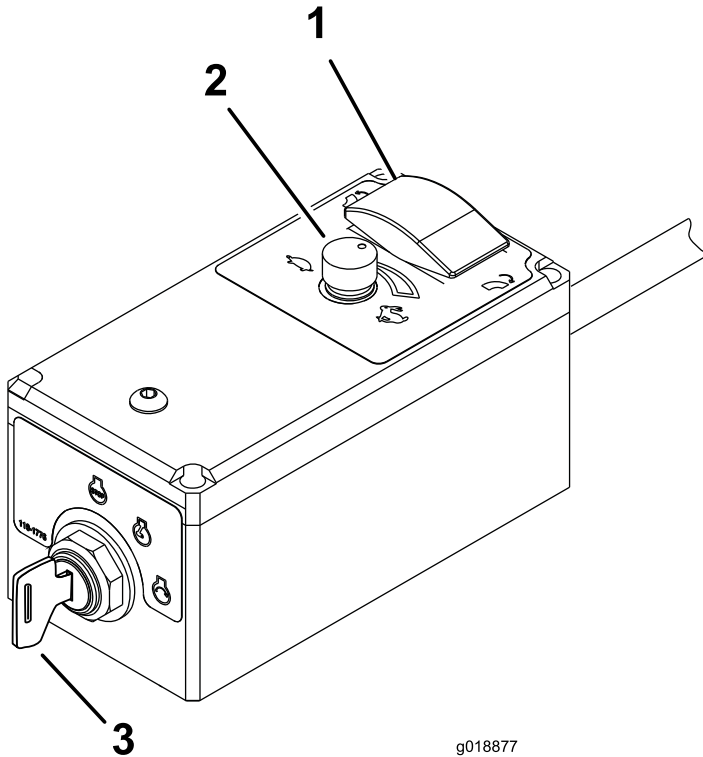

Figure 11

1. Nozzle direction button
2. Throttle/Engine speed
3. Ignition switch

Using the Chute Position Indicator

When the green indicator tab is visible in the rotation gauge window, the chute is positioned on the left side. When the red indicator tab is visible in the window, the chute is positioned on the right side (Figure 12).

The decal on the rotation gauge indicates the position of the chute relative to the ground.

When an indicator tab is in the same colored region on the decal, that indicates that the chute opening is positioned more parallel to the ground.

When an indicator tab is in the different colored region on the decal, that indicates that the chute opening is positioned more toward the ground.

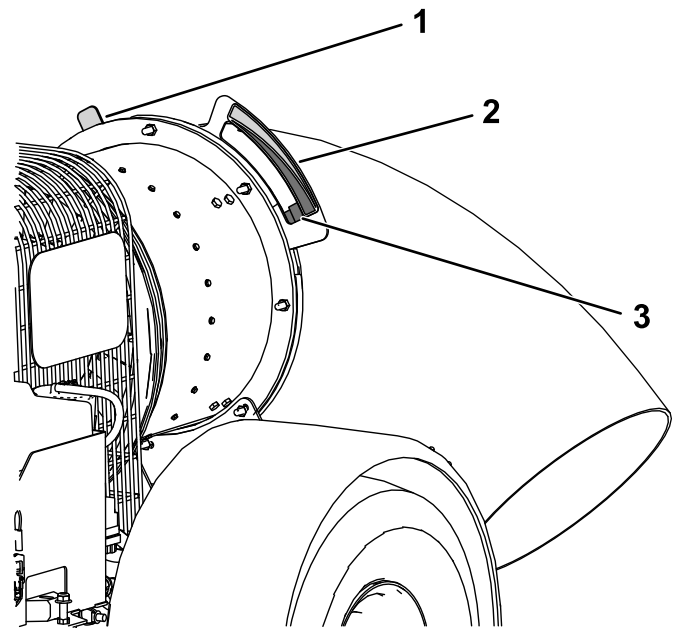

Figure 12

Left side shown, some parts hidden for clarity.

1. Red indicator tab
2. Rotation gauge and decal
3. Green indicator tab (in gauge window when the chute is toward the left side)

Operating Tips

- Practice operating the blower. Blow the same direction the wind is blowing to prevent material from blowing back into the cleared area.
- Run the engine at full throttle when operating.
- Adjust the blower nozzle opening so it blows under the debris.
- Use caution when blowing around newly planted sod as the force of the air could disrupt the grass.

Important: Raise the blower nozzle before transporting the blower. If you leave the blower nozzle in the down position during transport, it may contact the ground and become damaged.

After Operation

After Operation Safety

General Safety

- Park the machine on a firm, level surface; shut off the engine, remove the key, wait for all moving parts to stop, and allow the machine to cool before adjusting, repairing, cleaning, or storing the machine.
- Only disconnect the machine from the traction unit while on a level surface.
- When disconnecting the machine, always chock the wheels to prevent movement.
- Do not store the machine or fuel container where there is an open flame, spark, or pilot light, such as on a water heater or other appliance.
- Keep all parts of the machine in good working condition and all hardware tightened.
- Replace all worn, damaged, or missing decals.

Towing Safety

- Before towing the machine, check with your local county or state safety towing regulations, in addition to meeting Department of Transportation (DOT) safety towing regulations.
- Always shut off the engine and point the blower nozzle up before transporting.
- Tow only with a machine that has a hitch designed for towing. Do not attach towed equipment except at the hitch point.
- Always inspect the hitch and coupling for wear. Do not tow the machine with damaged or missing hitches, couplings, or chains.
- Check the tire air pressure on the machine. The tires should be inflated to 241 kpa (35 psi) cold. Also, check the tire-tread wear on the machine.
- Always properly attach the machine safety chains to the towing vehicle.
- Do not tow the machine faster than 88 km/h (55 mph). When off-road towing do not exceed 24 km/h (15 mph).
- Avoid sudden stops and starts. This can cause skidding or jack knifing. Smooth, gradual starts and stops improve towing.
- Avoid sharp turns to prevent rolling.
- Chock the wheels to whenever you park the blower.

Hauling

- Use care when loading or unloading the machine into a trailer or truck.
- Use full-width ramps for loading machine into a trailer or truck.
- Tie the machine down securely using straps, chains, cable, or ropes. Both front and rear straps should be directed down and outward from the machine.

Maintenance

⚠ CAUTION

Failure to properly maintain the machine could result in premature failure of machine systems causing possible harm to you or bystanders.

Keep the machine well maintained and in good working order as indicated in these instructions.

Note: Determine the left and right sides of the machine from the normal operating position.

Note: Download a free copy of the electrical or hydraulic schematic by visiting www.Toro.com and searching for your machine from the Manuals link on the home page.

Important: Refer to your engine owner's manual for additional maintenance procedures.

⚠ WARNING

If you leave the key in the ignition switch, someone could accidentally start the engine and seriously injure you or other bystanders.

Remove the key from the ignition and disconnect the wires from the spark plugs before you do any maintenance. Set the wires aside so that they do not accidentally contact the spark plugs.

Maintenance Safety

- Before cleaning, servicing, or adjusting the machine, do the following:
 - Park the machine on a level surface.
 - Shut off the engine, remove the key, disconnect the spark-plug wire, and wait for all moving parts to stop.
 - Chock the wheels.
 - Remove the machine from the traction unit.
 - Allow machine components to cool before performing maintenance.
- Perform only those maintenance instructions described in this manual. If major repairs are ever needed or you need assistance, contact an authorized Toro distributor.
- Support the machine with blocks or jack stands when working beneath it.
- Ensure that all guards are installed securely after maintaining or adjusting the machine.
- Do not allow untrained personnel to service the machine.
- Use jack stands to support the machine or components when required.
- Carefully release pressure from components with stored energy.
- Do not charge the batteries while servicing the machine.
- To reduce the potential fire hazard, keep the engine area free of excessive grease, grass, leaves, and accumulation of dirt.
- If possible, do not perform maintenance while the engine is running. Keep away from moving parts.
- If you must run the engine to perform a maintenance adjustment, keep your hands, feet, clothing, and all other parts of your body away from the engine and any moving parts. Keep bystanders away from the machine.
- Clean up oil and fuel spills.
- Keep all parts in good working condition and all fasteners tightened. Replace all damaged or missing decals.
- Do not interfere with the intended function of a safety device or reduce the protection provided by a safety device. Check their proper operation regularly.
- Do not overspeed the engine by changing the governor settings. To ensure safety and accuracy, have an authorized Toro distributor to check the maximum engine speed with a tachometer.
- If major repairs are ever necessary or assistance is required, contact an authorized Toro distributor.
- Altering this machine in any manner may affect the operation of the machine, performance, durability, or its use may result in injury or death. Such use could void the product warranty of The Toro® Company.

Recommended Maintenance Schedule(s)

Maintenance Service Interval	Maintenance Procedure
After the first 8 hours	<ul style="list-style-type: none"> • Check the condition and the tension of the belt.
After the first 10 hours	<ul style="list-style-type: none"> • Check the torque of the wheel lug nuts.
Before each use or daily	<ul style="list-style-type: none"> • Check the engine oil level. • Clean the engine screen and the oil cooler. • Check the nozzle clamp and the nozzle guides.
Every 25 hours	<ul style="list-style-type: none"> • Clean the foam air filter element and check the paper element for damage (more frequently if conditions are dusty or sandy).
Every 50 hours	<ul style="list-style-type: none"> • Check the condition and the tension of the belt.
Every 100 hours	<ul style="list-style-type: none"> • Replace the paper air filter element (more frequently if conditions are dusty or sandy). • Change the engine oil. • Check the condition of the tires.
Every 200 hours	<ul style="list-style-type: none"> • Replace the carbon-canister air filter (Service more frequently if conditions are extremely dusty or sandy). • Replace the carbon-canister purge-line filter. • Replace the oil filter. • Check the spark plugs.
Every 500 hours	<ul style="list-style-type: none"> • Replace the fuel filter.

Daily Maintenance Checklist

Duplicate this page for routine use.

Maintenance Check Item	For the week of:						
	Mon.	Tues.	Wed.	Thurs.	Fri.	Sat.	Sun.
Check the instrument operation							
Check the fuel level.							
Check the engine oil level.							
Clean the engine air cooling fins.							
Inspect the air filter pre-cleaner.							
Check any unusual engine noises.							
Check for fluid leaks.							
Check the tire pressure.							
Check blower nozzle mounting clamp torque							
Touch-up damaged paint.							

Notation for Areas of Concern		
Inspection performed by:		
Item	Date	Information

Engine Maintenance

Engine Safety

- Shut off the engine before checking the oil or adding oil to the crankcase.
- Do not change the governor speed or overspeed the engine.

Servicing the Air Cleaner

Service Interval: Every 25 hours—Clean the foam air filter element and check the paper element for damage (more frequently if conditions are dusty or sandy).

Every 100 hours—Replace the paper air filter element (more frequently if conditions are dusty or sandy).

Checking the Air Filter

1. Check the air cleaner body for damage, which could possibly cause an air leak. Ensure the cover is sealing around the air cleaner body (Figure 13).

Note: Replace a damaged air cleaner cover or housing.

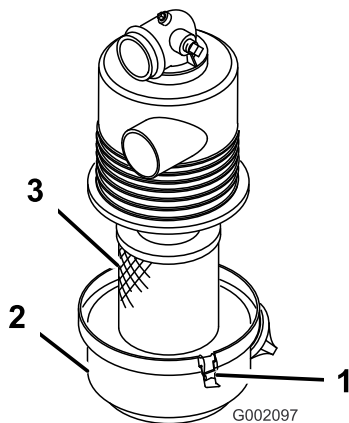

Figure 13

g002097

1. Latch
2. Air-filter housing
3. Air-filter element

2. Release the latches securing the air-filter cover to the air-filter housing (Figure 13).

3. Separate the air-filter cover from the air-filter housing, and clean the inside of the cover (Figure 13).
4. Gently slide the air-filter element out of the filter housing.

Note: To reduce the amount of dust dislodged, avoid knocking the filter against the air-filter housing.

5. Inspect the air-filter element.
 - If the air-filter element is clean, install the filter element, refer to [Installing the Air Filter \(page 19\)](#).
 - If the air-filter element is damaged, replace the filter element; refer to [Replacing the Air Filter \(page 19\)](#).

Replacing the Air Filter

1. Remove the air-filter element; refer to [Servicing the Air Cleaner \(page 19\)](#).

2. Inspect the new filter for shipping damage.

Note: Check the sealing end of the filter.

Important: Do not install a damaged filter.

3. Install the new air filter; refer to [Installing the Air Filter \(page 19\)](#).

Installing the Air Filter

Important: To prevent engine damage, always operate the engine with the complete air-cleaner assembly installed.

Important: Do not use a damaged element.

Note: Cleaning of the used air-filter element is not recommended due to the possibility of damage to the filter media.

1. Clean the dirt ejection port located on the air-filter cover.
2. Remove the rubber outlet valve from the cover, clean the cavity, and replace the outlet valve.
3. Insert the air-filter element into air-filter housing (Figure 13).

Note: Ensure that the filter is sealed properly by applying pressure to the outer rim of the filter when installing it. Do not press on the flexible center of the filter.

4. Align the air-cleaner cover with the air-cleaner housing (Figure 13).

Checking the Engine Oil Level

Service Interval: Before each use or daily

Note: The best time to check the engine oil is when the engine is cool before it has been started for the day. If it has already been run, allow the oil to drain back down to the sump for at least 10 minutes before checking. If the oil level is at or below the ADD mark on the dipstick, add oil to bring the oil level to the FULL mark. **Do not overfill.** If the oil level is between the FULL and ADD marks, no oil addition is required.

1. Park the machine on a level surface.
2. Shut off the engine, remove the key, and wait for all moving parts to stop before leaving the operating position.
3. Clean around the oil dipstick (Figure 17) so that dirt cannot fall into the filler hole and damage the engine.

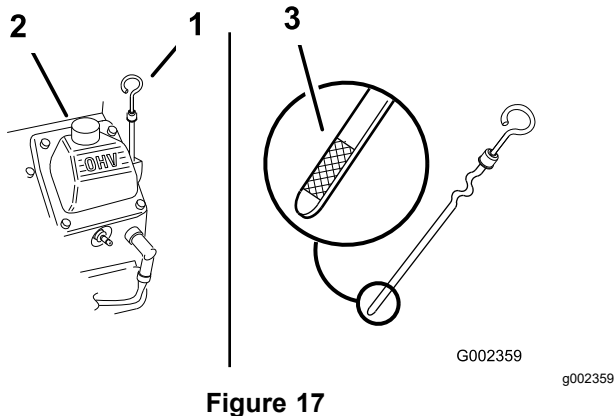

Figure 17

1. Oil dipstick
2. Filler tube

4. Unscrew the oil dipstick and wipe the end clean (Figure 17).
5. Slide the oil dipstick fully into the filler tube, but do not thread it onto the tube (Figure 17).
6. Pull the dipstick out and look at the metal end. If the oil level is low, slowly pour only enough oil into the filler tube to raise the level to the FULL mark.

Important: Do not overfill the crankcase with oil and run the engine. Engine damage can result.

Changing the Oil

Service Interval: Every 100 hours

1. Start the engine and let it run 5 minutes. This warms the oil so that it drains better.
2. Park the machine so that the drain side is slightly lower than the opposite side to ensure that the oil drains completely.
3. Shut off the engine, remove the key, and wait for all moving parts to stop before leaving the operating position.
4. Place a pan below the drain. Rotate the oil drain valve to allow the oil to drain (Figure 18).

Note: Insert a hose may be inserted onto the drain valve to direct the oil flow. The hose is not included with the machine.

5. When the oil has drained completely, close the drain valve.

Note: Dispose of the used oil at a recycling center.

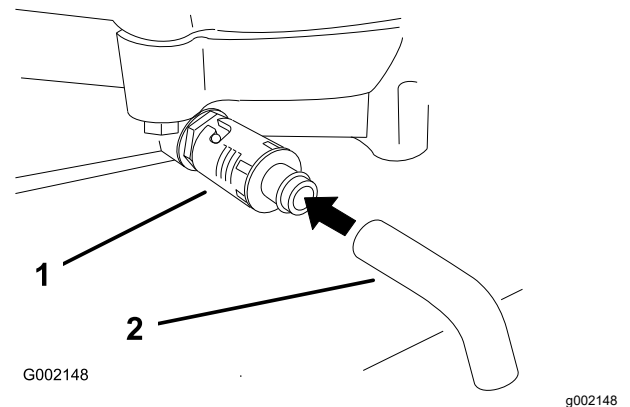

Figure 18

1. Oil drain valve
2. Oil drain hose (**Not included**)

6. Slowly pour approximately 80% of the specified oil into the filler tube (Figure 17).
7. Check the oil level; refer to [Checking the Engine Oil Level \(page 21\)](#).
8. Slowly add the additional oil to bring it to the Full mark.

Changing the Oil Filter

Service Interval: Every 200 hours

Note: Change the oil filter more frequently when the operating conditions are extremely dusty or sandy.

1. Drain the oil from the engine; refer to [Changing the Oil \(page 21\)](#).
2. Remove the old filter and wipe the filler adapter gasket surface ([Figure 19](#)).

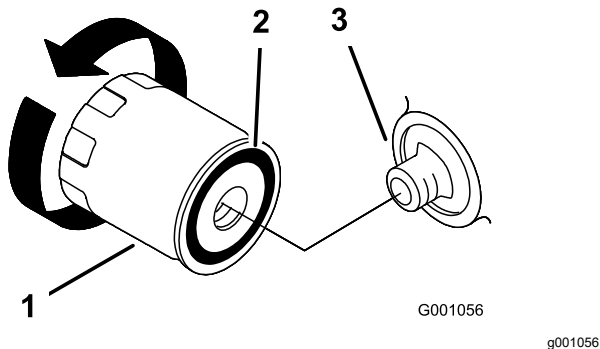

Figure 19

1. Oil filter
2. Adapter gasket
3. Adapter

3. Apply a thin coat of new oil to the rubber gasket on the replacement filter ([Figure 19](#)).
4. Install the replacement oil filter to the filter adapter, turn the oil filter clockwise until the rubber gasket contacts the filter adapter, then tighten the filter an additional 2/3 to 1 turn ([Figure 19](#)).
5. Fill the crankcase with the proper type of new oil; refer to [Servicing the Engine Oil \(page 20\)](#).
6. Run the engine for about 3 minutes, shut off the engine, and check for oil leaks around the oil filter.
7. Check the engine oil level and add oil if needed.

Servicing the Spark Plugs

Ensure that the air gap between the center and side electrodes is correct before installing the spark plugs. Use a spark plug wrench for removing and installing the spark plugs and a gapping tool/feeler gauge to check and adjust the air gap. Install new spark plugs if necessary.

Type: Champion® RC12YC, Champion® Platinum 3071 or equivalent

Air Gap: 0.76 mm (0.030 inch)

Checking the Spark Plugs

Service Interval: Every 200 hours

1. Look at the center of the spark plugs ([Figure 20](#)). If you see light brown or gray on the insulator, the engine is operating properly. A black coating on the insulator usually means that the air cleaner is dirty.

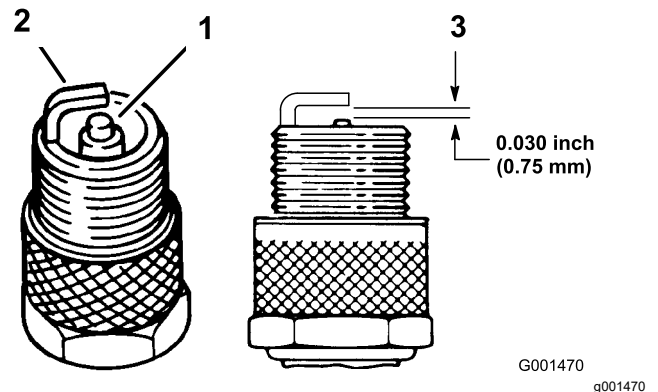

Figure 20

1. Center electrode insulator
2. Side electrode
3. Air gap (not to scale)

Important: Always replace a spark plug when it has a black coating, worn electrodes, an oily film, or cracks.

2. Check the gap between the center and side electrodes ([Figure 20](#)). Bend the side electrode ([Figure 20](#)) if the gap is not correct.

Removing the Spark Plugs

1. Shut off the engine, remove the key, and wait for all moving parts to stop before leaving the operating position.
2. Disconnect the wires from the spark plugs ([Figure 21](#)).

Fuel System Maintenance

Replacing the Fuel Filter

Service Interval: Every 500 hours

Never install a dirty filter if it is removed from the fuel line.

1. Shut off the engine, remove the key, and wait for all moving parts to stop before leaving the operating position.
2. Allow the machine to cool down.
3. Squeeze the ends of the hose clamps together and slide them away from the filter ([Figure 23](#)).

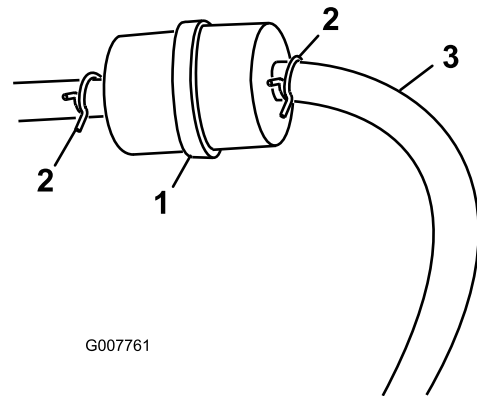

G007761

g007761

Figure 23

1. Fuel filter
2. Hose clamp
3. Fuel hose

4. Remove the filter from the fuel lines.
5. Install a new filter and move the hose clamps close to the filter ([Figure 23](#)).

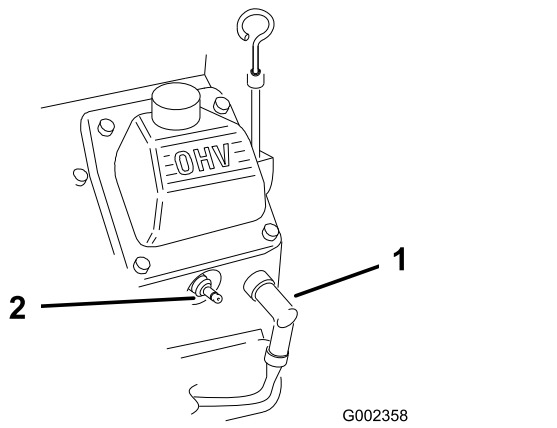

G002358

g002358

Figure 21

1. Spark-plug wire
2. Spark plug

3. Clean around the spark plugs to prevent dirt from falling into the engine and potentially causing damage.
4. Remove the spark plugs and the metal washers.

Installing the Spark Plugs

1. Install the spark plugs and the metal washer. Ensure that the air gap is set correctly.
2. Tighten the spark plugs to 24.4 to 29.8 N-m (18 to 22 ft-lb).
3. Connect the wires to the spark plugs ([Figure 20](#)).

Cleaning the Engine Screen and the Oil Cooler

Service Interval: Before each use or daily

Before each use, check and clean the engine screen and oil cooler. Remove any build up of grass, dirt or other debris from the oil cooler and engine screen ([Figure 22](#)).

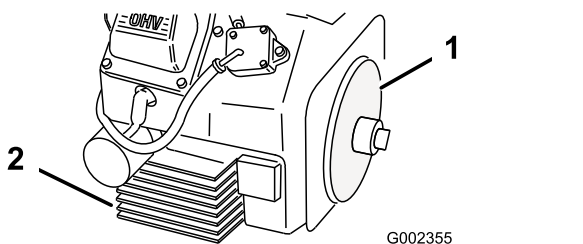

G002355

g002355

Figure 22

1. Engine screen
2. Oil cooler

Servicing the Fuel Tank

▲ DANGER

In certain conditions, fuel is extremely flammable and highly explosive. A fire or explosion from fuel can burn you and others and can damage property.

- Drain fuel from the fuel tank when the engine is cold. Do this outdoors in an open area. Wipe up any fuel that spills.
- Never smoke when draining fuel, and stay away from an open flame or where a spark may ignite the fuel fumes.

1. Park the machine on a level surface to ensure that the fuel tanks drain completely.
2. Shut off the engine, remove the key, and wait for all moving parts to stop before leaving the operating position.
3. Loosen the hose clamp at the fuel filter and slide it up the fuel line away from the fuel filter (Figure 23).
4. Disconnect the fuel line from the fuel filter (Figure 23).

Note: Allow fuel to drain into a fuel container can or drain pan (Figure 23).

Note: This is the best time to install a new fuel filter because the fuel tank is empty.

5. Install the fuel line onto the fuel filter. Slide the hose clamp close to the fuel filter to secure the fuel line (Figure 23).

Electrical System Maintenance

Important: Before welding on the machine, disconnect the controller and the negative cable from the battery to prevent damage to the electrical system.

Electrical System Safety

- Disconnect the battery before repairing the machine. Disconnect the negative terminal first and the positive last. Connect the positive terminal first and the negative last.
- Charge the battery in an open, well-ventilated area, away from sparks and flames. Unplug the charger before connecting or disconnecting the battery. Wear protective clothing and use insulated tools.

Replacing the Fuses

Engine

A 15 A in-line fuse is incorporated into the engine wire harness (Figure 24).

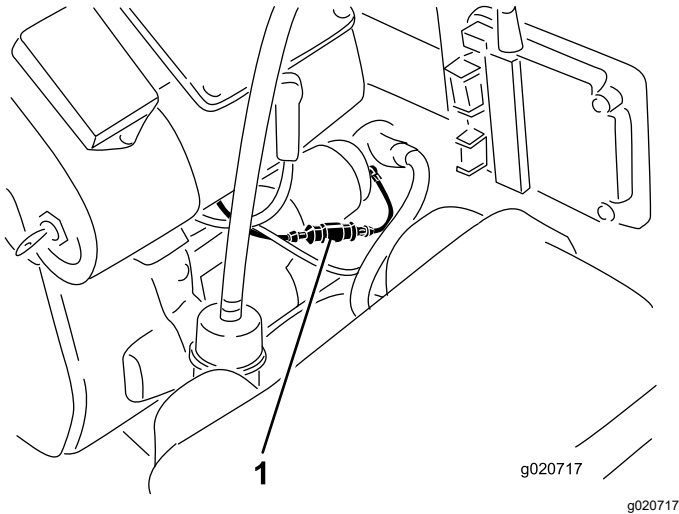

Figure 24

1. Fuse

Receiver

An fuse block is incorporated into the receiver wire harness. It is located behind the receiver on the right side the of control tower (Figure 25).

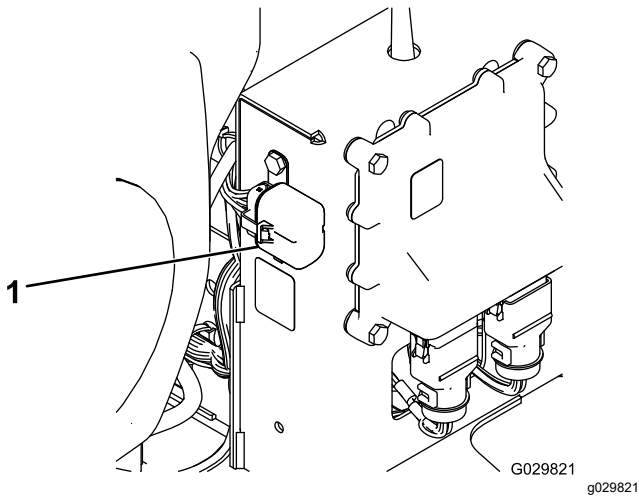

Figure 25

1. Fuse

Drive System Maintenance

Inspecting the Tires

Service Interval: Every 100 hours

Check the tire pressure frequently to ensure proper inflation (97 kPa (14 psi)). If the tires are not inflated to the correct pressure, the tires wear prematurely.

Operating accidents can damage a tire or rim, so inspect the tire condition after an accident.

The DOT tire information is located on the side of each tire. This information gives load and speed ratings. Replacement tires should have the same or better ratings.

Figure 26 is an example of tire wear caused by under inflation.

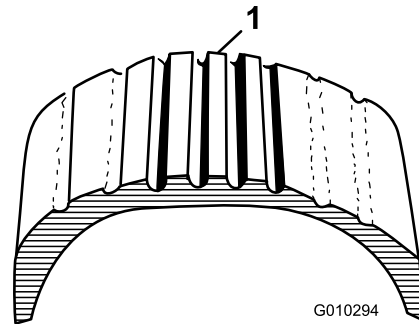

Figure 26

1. Example of tire wear caused by underinflation

Figure 27 is an example of tire wear caused by over inflation.

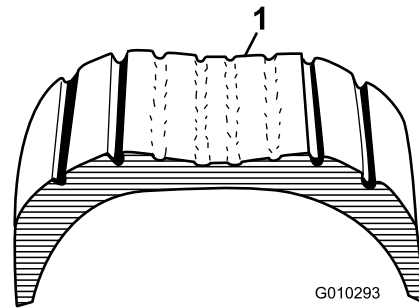

Figure 27

1. Example of tire wear caused by overinflation

Belt Maintenance

Adjusting the Belt

Service Interval: After the first 8 hours

Every 50 hours

If the belt slips when changing the direction of the nozzle, an adjustment to the belt is required.

1. Loosen the bolts securing the pulley mounting bracket to the blower frame (Figure 28).
2. Position a torque wrench into the pulley mounting bracket (Figure 28).
3. Pivot the pulley mounting bracket away from the nozzle until the torque wrench reads 22.6 to 26.0 N-m (200 to 230 in-lb) (Figure 28).
4. Tighten the mounting bolts.

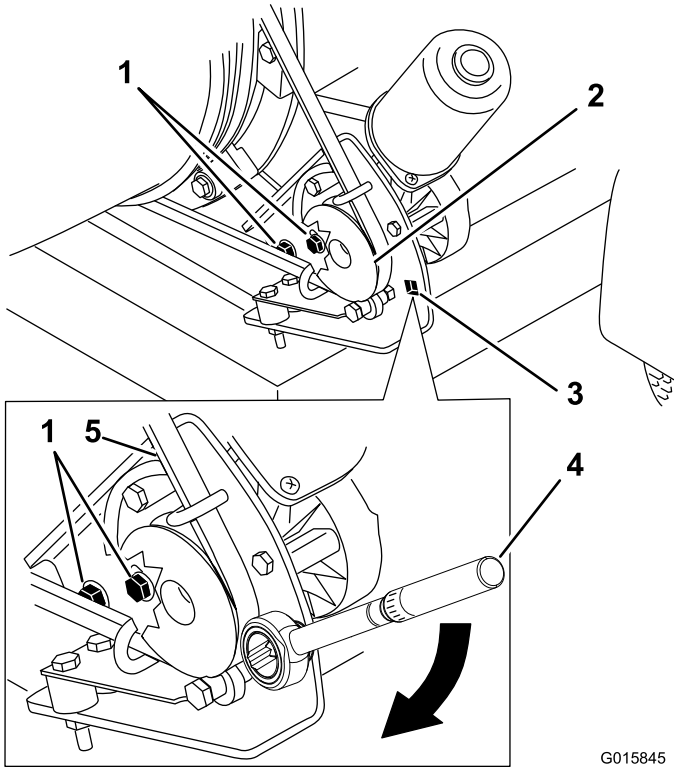

Figure 28

G015845
g015845

1. Mounting bolts
2. Pulley
3. Hole for torque wrench
4. Torque wrench in pulley mounting bracket [22.6 to 26.0 N-m (200 to 230 in-lb)]
5. Belt

Miscellaneous Maintenance

Checking the Nozzle

Service Interval: Before each use or daily

Checking the Nozzle Clamp

Check the nozzle clamp (Figure 29) daily to assure it is tight. If the nozzle is dragged over obstacles or through low areas in the terrain it could be knocked loose from the clamp. Torque the clamp fasteners to 5.1-5.7 N-m (45-50 in-lb).

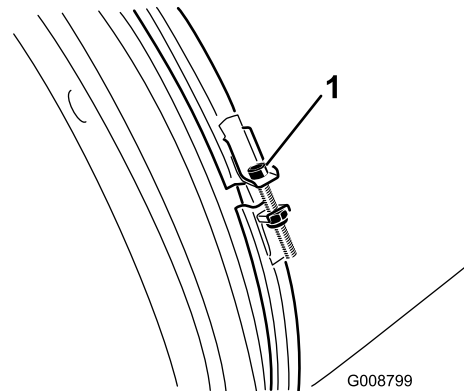

Figure 29

G008799

g008799

1. Nozzle clamp

Cleaning the Nozzle Guides

Check and remove any grass, dirt or debris buildup around and in between the nozzle guides (Figure 30). If the nozzle guides are not kept free of debris, the nozzle may not rotate freely which could cause the motor to stall.

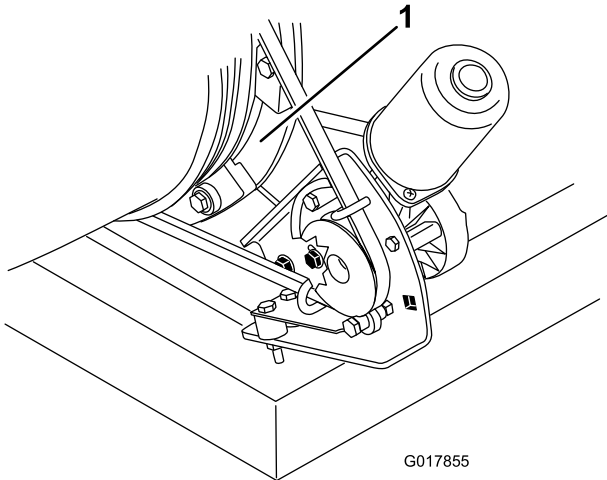

Figure 30

1. Nozzle guides
-

Storage

Storage

1. Shut off the engine, remove the spark plug wire, and remove the key from the ignition.
2. Remove grass clippings, dirt, and grime from the external parts of the machine, especially the engine. Clean dirt and chaff from the outside of the engine cylinder head fins and blower housing.

Important: You can wash the machine with mild detergent and water. Do not pressure-wash the machine. Avoid excessive use of water.

3. Service the air cleaner; refer to [Servicing the Air Cleaner \(page 19\)](#).
4. Change the crankcase oil; refer to [Servicing the Engine Oil \(page 20\)](#).
5. Check the tire pressure; refer to [Checking the Tire Pressure \(page 12\)](#).
6. Prepare the machine for storage when non-use occurs over 30 days. Prepare machine for storage as follows:

- A. Add a petroleum-based stabilizer/conditioner to fuel in the tank. Follow mixing instructions from stabilizer manufacture. Do not use an alcohol based stabilizer (ethanol or methanol).

Note: A fuel stabilizer/conditioner is most effective when mixed with fresh fuel and used at all times.
- B. Run the engine to distribute conditioned fuel through the fuel system for 5 minutes.
- C. Shut off the engine, allow it to cool, and drain the fuel tank; refer to [Servicing the Fuel Tank \(page 24\)](#).
- D. Start the engine and run it until it stops.
- E. Choke the engine. Start and run the engine until it does not start.
- F. Dispose of fuel properly. Recycle according to local codes.

Important: Do not store stabilizer/conditioned fuel over 90 days.

7. Remove the spark plug(s) and check its condition; refer to [Servicing the Spark Plugs \(page 22\)](#). With the spark plug(s) removed from the engine, pour 30 ml (2 tablespoons) of engine oil into the spark-plug hole. Then use the starter to crank the engine and distribute the oil inside the cylinder. Install the spark plug(s). Do not install the wire on the spark plug(s).

8. Check and tighten all hardware. Repair or replace any part that is damaged or defective.
9. Paint all scratched or bare metal surfaces. Paint is available from your Authorized Service Dealer.
10. Store the machine in a clean, dry garage or storage area. Remove the key from the ignition switch and keep it out of reach of children or other unauthorized users. Cover the machine to protect it and keep it clean.

Waste Disposal

Engine oil, engine and remote control batteries are pollutants to the environment. Dispose of these according to your state and local regulations.

Notes:

EEA/UK Privacy Notice

Toro's Use of Your Personal Information

The Toro Company ("Toro") respects your privacy. When you purchase our products, we may collect certain personal information about you, either directly from you or through your local Toro company or dealer. Toro uses this information to fulfil contractual obligations - such as to register your warranty, process your warranty claim or to contact you in the event of a product recall - and for legitimate business purposes - such as to gauge customer satisfaction, improve our products or provide you with product information which may be of interest. Toro may share your information with our subsidiaries, affiliates, dealers or other business partners in connection these activities. We may also disclose personal information when required by law or in connection with the sale, purchase or merger of a business. We will never sell your personal information to any other company for marketing purposes.

Retention of your Personal Information

Toro will keep your personal information as long as it is relevant for the above purposes and in accordance with legal requirements. For more information about applicable retention periods please contact legal@toro.com.

Toro's Commitment to Security

Your personal information may be processed in the US or another country which may have less strict data protection laws than your country of residence. Whenever we transfer your information outside of your country of residence, we will take legally required steps to ensure that appropriate safeguards are in place to protect your information and to make sure it is treated securely.

Access and Correction

You may have the right to correct or review your personal data, or object to or restrict the processing of your data. To do so, please contact us by email at legal@toro.com. If you have concerns about the way in which Toro has handled your information, we encourage you to raise this directly with us. Please note that European residents have the right to complain to your Data Protection Authority.

California Proposition 65 Warning Information

What is this warning?

You may see a product for sale that has a warning label like the following:



WARNING: Cancer and Reproductive Harm—www.p65Warnings.ca.gov.

What is Prop 65?

Prop 65 applies to any company operating in California, selling products in California, or manufacturing products that may be sold in or brought into California. It mandates that the Governor of California maintain and publish a list of chemicals known to cause cancer, birth defects, and/or other reproductive harm. The list, which is updated annually, includes hundreds of chemicals found in many everyday items. The purpose of Prop 65 is to inform the public about exposure to these chemicals.

Prop 65 does not ban the sale of products containing these chemicals but instead requires warnings on any product, product packaging, or literature with the product. Moreover, a Prop 65 warning does not mean that a product is in violation of any product safety standards or requirements. In fact, the California government has clarified that a Prop 65 warning "is not the same as a regulatory decision that a product is 'safe' or 'unsafe.'" Many of these chemicals have been used in everyday products for years without documented harm. For more information, go to <https://oag.ca.gov/prop65/faqs-view-all>.

A Prop 65 warning means that a company has either (1) evaluated the exposure and has concluded that it exceeds the "no significant risk level"; or (2) has chosen to provide a warning based on its understanding about the presence of a listed chemical without attempting to evaluate the exposure.

Does this law apply everywhere?

Prop 65 warnings are required under California law only. These warnings are seen throughout California in a wide range of settings, including but not limited to restaurants, grocery stores, hotels, schools, and hospitals, and on a wide variety of products. Additionally, some online and mail order retailers provide Prop 65 warnings on their websites or in catalogs.

How do the California warnings compare to federal limits?

Prop 65 standards are often more stringent than federal and international standards. There are various substances that require a Prop 65 warning at levels that are far lower than federal action limits. For example, the Prop 65 standard for warnings for lead is 0.5 µg/day, which is well below the federal and international standards.

Why don't all similar products carry the warning?

- Products sold in California require Prop 65 labelling while similar products sold elsewhere do not.
- A company involved in a Prop 65 lawsuit reaching a settlement may be required to use Prop 65 warnings for its products, but other companies making similar products may have no such requirement.
- The enforcement of Prop 65 is inconsistent.
- Companies may elect not to provide warnings because they conclude that they are not required to do so under Prop 65; a lack of warnings for a product does not mean that the product is free of listed chemicals at similar levels.

Why does Toro include this warning?

Toro has chosen to provide consumers with as much information as possible so that they can make informed decisions about the products they buy and use. Toro provides warnings in certain cases based on its knowledge of the presence of one or more listed chemicals without evaluating the level of exposure, as not all the listed chemicals provide exposure limit requirements. While the exposure from Toro products may be negligible or well within the "no significant risk" range, out of an abundance of caution, Toro has elected to provide the Prop 65 warnings. Moreover, if Toro does not provide these warnings, it could be sued by the State of California or by private parties seeking to enforce Prop 65 and subject to substantial penalties.



The Toro Warranty

Two-Year or 1,500 Hours Limited Warranty

Conditions and Products Covered

The Toro Company warrants your Toro Commercial product ("Product") to be free from defects in materials or workmanship for 2 years or 1,500 operational hours*, whichever occurs first. This warranty is applicable to all products with the exception of Aerators (refer to separate warranty statements for these products). Where a warrantable condition exists, we will repair the Product at no cost to you including diagnostics, labor, parts, and transportation. This warranty begins on the date the Product is delivered to the original retail purchaser.

* Product equipped with an hour meter.

Instructions for Obtaining Warranty Service

You are responsible for notifying the Commercial Products Distributor or Authorized Commercial Products Dealer from whom you purchased the Product as soon as you believe a warrantable condition exists. If you need help locating a Commercial Products Distributor or Authorized Dealer, or if you have questions regarding your warranty rights or responsibilities, you may contact us at:

Toro Commercial Products Service Department
8111 Lyndale Avenue South
Bloomington, MN 55420-1196

952-888-8801 or 800-952-2740
E-mail: commercial.warranty@toro.com

Owner Responsibilities

As the product owner, you are responsible for required maintenance and adjustments stated in your *Operator's Manual*. Repairs for product issues caused by failure to perform required maintenance and adjustments are not covered under this warranty.

Items and Conditions Not Covered

Not all product failures or malfunctions that occur during the warranty period are defects in materials or workmanship. This warranty does not cover the following:

- Product failures which result from the use of non-Toro replacement parts, or from installation and use of add-on, or modified non-Toro branded accessories and products.
- Product failures which result from failure to perform recommended maintenance and/or adjustments.
- Product failures which result from operating the Product in an abusive, negligent, or reckless manner.
- Parts consumed through use that are not defective. Examples of parts which are consumed, or used up, during normal Product operation include, but are not limited to, brake pads and linings, clutch linings, blades, reels, rollers and bearings (sealed or greasable), bed knives, spark plugs, castor wheels and bearings, tires, filters, belts, and certain sprayer components such as diaphragms, nozzles, flow meters, and check valves.
- Failures caused by outside influence, including, but not limited to, weather, storage practices, contamination, use of unapproved fuels, coolants, lubricants, additives, fertilizers, water, or chemicals.
- Failure or performance issues due to the use of fuels (e.g. gasoline, diesel, or biodiesel) that do not conform to their respective industry standards.
- Normal noise, vibration, wear and tear, and deterioration. Normal "wear and tear" includes, but is not limited to, damage to seats due to wear or abrasion, worn painted surfaces, scratched decals or windows.

Countries Other than the United States or Canada

Customers who have purchased Toro products exported from the United States or Canada should contact their Toro Distributor (Dealer) to obtain guarantee policies for your country, province, or state. If for any reason you are dissatisfied with your Distributor's service or have difficulty obtaining guarantee information, contact your Authorized Toro Service Center.

Parts

Parts scheduled for replacement as required maintenance are warranted for the period of time up to the scheduled replacement time for that part. Parts replaced under this warranty are covered for the duration of the original product warranty and become the property of Toro. Toro will make the final decision whether to repair any existing part or assembly or replace it. Toro may use remanufactured parts for warranty repairs.

Deep Cycle and Lithium-Ion Battery Warranty

Deep cycle and Lithium-Ion batteries have a specified total number of kilowatt-hours they can deliver during their lifetime. Operating, recharging, and maintenance techniques can extend or reduce total battery life. As the batteries in this product are consumed, the amount of useful work between charging intervals will slowly decrease until the battery is completely worn out. Replacement of worn out batteries, due to normal consumption, is the responsibility of the product owner. Note: (Lithium-Ion battery only): Refer to the battery warranty for additional information.

Lifetime Crankshaft Warranty (ProStripe 02657 Model Only)

The ProStripe which is fitted with a genuine Toro Friction Disc and Crank-Safe Blade Brake Clutch (integrated Blade Brake Clutch (BBC) + Friction Disc assembly) as original equipment and used by the original purchaser in accordance with recommended operating and maintenance procedures, are covered by a Lifetime Warranty against engine crankshaft bending. Machines fitted with friction washers, Blade Brake Clutch (BBC) units and other such devices are not covered by the Lifetime Crankshaft Warranty.

Maintenance is at Owner's Expense

Engine tune-up, lubrication, cleaning and polishing, replacement of filters, coolant, and completing recommended maintenance are some of the normal services Toro products require that are at the owner's expense.

General Conditions

Repair by an Authorized Toro Distributor or Dealer is your sole remedy under this warranty.

The Toro Company is not liable for indirect, incidental or consequential damages in connection with the use of the Toro Products covered by this warranty, including any cost or expense of providing substitute equipment or service during reasonable periods of malfunction or non-use pending completion of repairs under this warranty. Except for the Emissions warranty referenced below, if applicable, there is no other express warranty. All implied warranties of merchantability and fitness for use are limited to the duration of this express warranty.

Some states do not allow exclusions of incidental or consequential damages, or limitations on how long an implied warranty lasts, so the above exclusions and limitations may not apply to you. This warranty gives you specific legal rights, and you may also have other rights which vary from state to state.

Note Regarding Emissions Warranty

The Emissions Control System on your Product may be covered by a separate warranty meeting requirements established by the U.S. Environmental Protection Agency (EPA) and/or the California Air Resources Board (CARB). The hour limitations set forth above do not apply to the Emissions Control System Warranty. Refer to the Engine Emission Control Warranty Statement supplied with your product or contained in the engine manufacturer's documentation.