



ProStripe® 560 Mower

Model No. 02657—Serial No. 407000000 and Up

Operator's Manual

Introduction

This rotary-blade, walk-behind lawn mower is intended to be used by professional, hired operators. It is designed primarily for cutting grass on well-maintained lawns on residential or commercial properties. Using this product for purposes other than its intended use could prove dangerous to you and bystanders.

Read this information carefully to learn how to operate and maintain your product properly and to avoid injury and product damage. You are responsible for operating the product properly and safely.

Visit www.Toro.com for product safety and operation training materials, accessory information, help finding a dealer, or to register your product.

Whenever you need service, genuine Toro parts, or additional information, contact an Authorized Service Dealer or Toro Customer Service and have the model and serial numbers of your product ready. **Figure 1** identifies the location of the model and serial numbers on the product. Write the numbers in the space provided.

Important: With your mobile device, you can scan the QR code on the serial number decal (if equipped) to access warranty, parts, and other product information

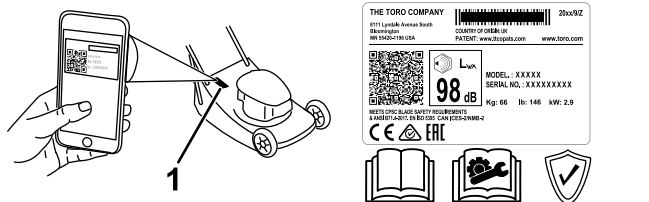

Figure 1

1. Model and serial number location

Write the product model and serial numbers in the space below:

<p>Model No. _____</p> <p>Serial No. _____</p>
--

This manual identifies potential hazards and has safety messages identified by the safety-alert symbol

(**Figure 2**), which signals a hazard that may cause serious injury or death if you do not follow the recommended precautions.



Figure 2
Safety-alert symbol

g000502

This manual uses 2 words to highlight information. **Important** calls attention to special mechanical information and **Note** emphasizes general information worthy of special attention.

This product complies with all relevant European directives; for details, see the separate product specific Declaration of Conformity (DOC) sheet.

It is a violation of California Public Resource Code Section 4442 or 4443 to use or operate the engine on any forest-covered, brush-covered, or grass-covered land unless the engine is equipped with a spark arrester, as defined in Section 4442, maintained in effective working order or the engine is constructed, equipped, and maintained for the prevention of fire.

The enclosed engine owner's manual is supplied for information regarding the US Environmental Protection Agency (EPA) and the California Emission Control Regulation of emission systems, maintenance, and warranty. Replacements may be ordered through the engine manufacturer.

Gross or Net Torque: The gross or net torque of this engine was laboratory rated by the engine manufacturer in accordance with the Society of Automotive Engineers (SAE) J1940 or J2723. As configured to meet safety, emission, and operating requirements, the actual engine torque on this class of mower will be significantly lower. Please refer to the engine manufacturer's information included with the machine.

Do not tamper with or disable safety devices on the machine, and check their proper operation regularly. Do not attempt to adjust or tamper with the engine speed control; doing so may create an unsafe operating condition, resulting in personal injury.



⚠ WARNING

CALIFORNIA Proposition 65 Warning

The engine exhaust from this product contains chemicals known to the State of California to cause cancer, birth defects, or other reproductive harm.

Use of this product may cause exposure to chemicals known to the State of California to cause cancer, birth defects, or other reproductive harm.

Contents

Introduction	1
Safety	2
General Safety	2
Safety and Instructional Decals	3
Setup	4
1 Assembling the Handle	4
2 Assembling the Grass Bag	6
3 Adding Oil to the Engine	7
Product Overview	8
Specifications	8
Operation	8
Before Operation	8
Before Operation Safety	8
Filling the Fuel Tank	9
Checking the Engine-Oil Level	9
Adjusting the Cutting Height	10
Starting the Engine	12
Engaging the Blade	12
Disengaging the Blade	13
Selecting the Speed	13
During Operation	14
During Operation Safety	14
Using the Self-Propel Drive	15
Shutting Off the Engine	15
Bagging the Clippings	15
Operating Tips	16
After Operation	17
After Operation Safety	17
Cleaning the Machine	17
Maintenance	18
Recommended Maintenance Schedule(s)	18
Maintenance Safety	18
Preparing for Maintenance	18
Servicing the Air Filter	19
Changing the Engine Oil	20
Adjusting the Self-Propel Cable	20
Replacing the Blade	21
Sharpening the Blade	22

Storage	23
Storage Safety	23
Preparing the Machine for Storage	23
Removing the Machine from Storage	23

Safety

This machine has been designed in accordance with EN ISO 5395 and ANSI B71.4-2017.

General Safety

This product is capable of amputating hands and feet and of throwing objects. Always follow all safety instructions to avoid serious personal injury or death.

- Read, understand, and follow the instructions and warnings in this *Operator's Manual* and on the machine and attachments before starting the engine.
- Do not put your hands or feet near moving parts or under the machine. Keep clear of any discharge opening.
- Do not operate the machine without all guards and other safety protective devices in place and functioning properly on the machine.
- Keep bystanders and children out of the operating area. Do not allow children to operate the machine. Allow only people who are responsible, trained, familiar with the instructions, and physically capable to operate the machine.
- Stop the machine, shut off the engine, and wait for all moving parts to stop before servicing, fueling, or unclogging the machine.

Improperly using or maintaining this machine can result in injury. To reduce the potential for injury, comply with these safety instructions and always pay attention to the safety-alert symbol **⚠**, which means Caution, Warning, or Danger—personal safety instruction. Failure to comply with these instructions may result in personal injury or death.

Safety and Instructional Decals



Safety decals and instructions are easily visible to the operator and are located near any area of potential danger. Replace any decal that is damaged or missing.

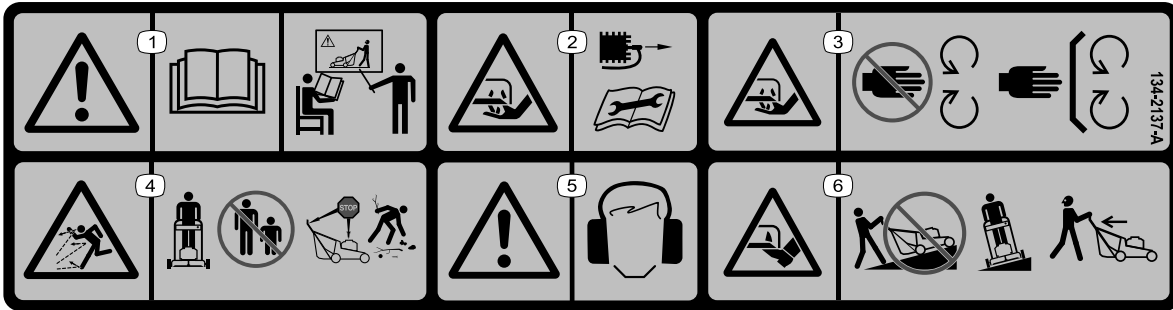

134-2137

decal134-2137

1. Warning—read the *Operator's Manual*; do not operate this machine unless you are trained.
2. Cutting/dismemberment hazard of the hand, mower blades—disconnect the spark plug before performing maintenance.
3. Cutting/dismemberment hazard of the hand, mower blades—stay away from moving parts; keep all guards and shields in place.
4. Thrown object hazard—keep bystanders away; shut off the engine before leaving the machine; pick up debris before mowing.
5. Warning—wear hearing protection.
6. Cutting/dismemberment hazard of the foot, mower blade—do not operate up and down slopes; only operate across slopes; look behind and down when moving in reverse.



94-8072

decal94-8072

1. Warning—cutting/dismemberment hazard of hand or foot, cutting mechanism.

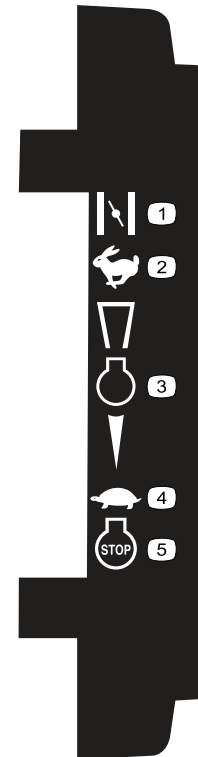

111-8959

decal111-8959

1. Choke
2. Fast
3. Engine
4. Slow
5. Engine—shut off

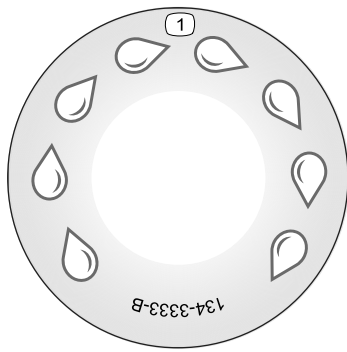

134-3333

decal134-3333

1. Quick-wash port

⚠ WARNING: Cancer and Reproductive Harm - www.P65Warnings.ca.gov.
For more information, please visit www.tcoCAProp65.com
CALIFORNIA SPARK ARRESTER WARNING
Operation of this equipment may create sparks that can start fires around dry vegetation. A spark arrester may be required. The operator should contact local fire agencies for laws or regulations relating to fire prevention requirements.

133-8062

decal133-8062

133-8062

Setup

Important: Remove and discard the protective plastic sheet that covers the engine.

1

Assembling the Handle

Parts needed for this procedure:

2	Lower handlebar (left)
2	Lower handlebar (right)
2	Clamp plate
2	Short bolt
4	Flat washer
6	Locknut
4	Cup washer
4	Long bolt
1	Upper handlebar
6	Cap

Procedure

⚠ WARNING

Assembling the handle improperly can damage the cables, causing an unsafe operating condition.

- Do not damage the cables when assembling the handle.
- Ensure that the cables are routed to the inside of the handle and do not catch the rear deflector.
- If a cable is damaged, contact your Authorized Service Dealer.

1. Remove the hex nuts from the 2 exposed bolts on the top of the deck.
2. Install a lower handlebar to each side of the top of the mower deck with a clamp plate and the hex locknut removed from the deck in the previous step (Figure 3).

Note: The lower handle tubes have a bend along the midsection; ensure that the tubes are

fitted so that the bent section of the tube angles toward the ground.

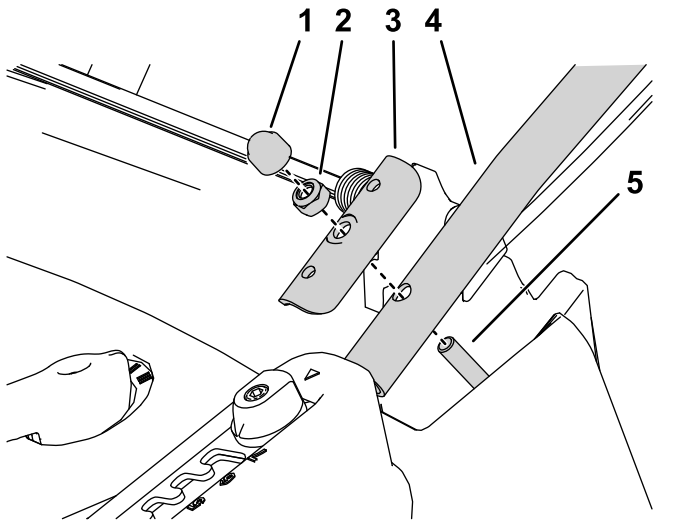

Figure 3
Left side shown

- | | |
|----------------|---|
| 1. Cap | 4. Lower handlebar |
| 2. Hex locknut | 5. Remove the hex nut and install the lower handlebar here. |
| 3. Clamp plate | |

3. Install the bottom of the brace handlebars to each side of the mower deck using a bolt, flat washers on the inside and outside of the deck, and a locknut (Figure 4).

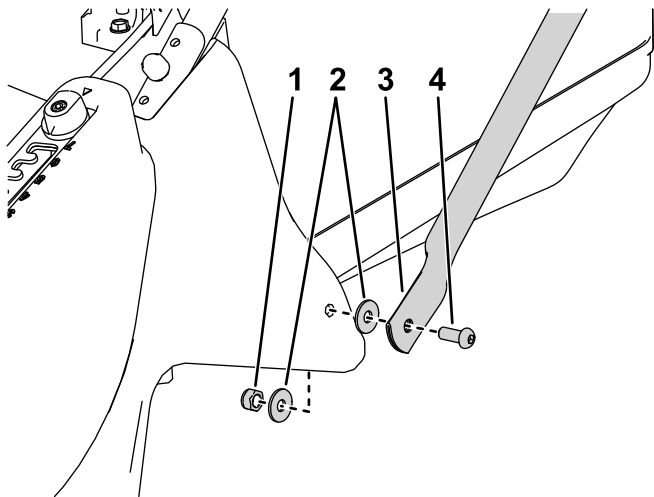

Figure 4
Left side shown

- | | |
|----------------|--------------------|
| 1. Hex locknut | 3. Brace handlebar |
| 2. Flat washer | 4. Bolt |

4. Install the upper handlebars and top of the brace handlebars to the lower handlebars with 3 cup

washers, 2 bolts and 2 hex locknuts on each side (Figure 5).

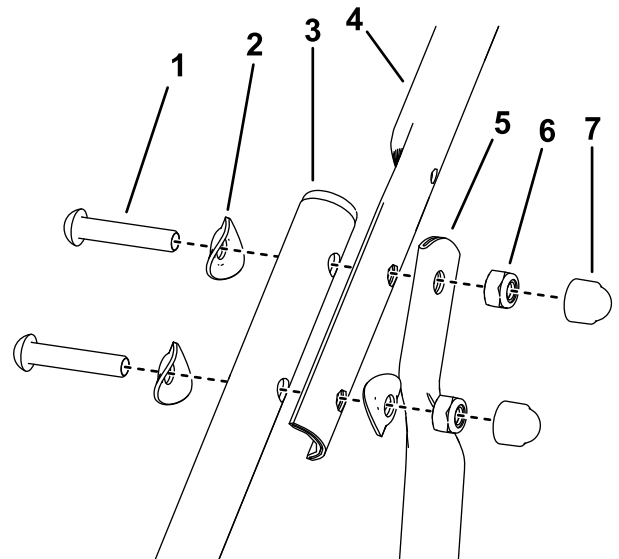

Figure 5
Left side shown

- | | |
|--------------------|--------------------|
| 1. Bolt | 5. Brace handlebar |
| 2. Cup washer | 6. Hex locknut |
| 3. Lower handlebar | 7. Cap |
| 4. Upper handlebar | |

5. Install caps over all of the exposed handlebar nuts.

2

Assembling the Grass Bag

No Parts Required

Procedure

1. To prevent accidents, cut off the white ribbon attached to the grass bag and discard.
2. Insert the frame into the grass bag, keeping the handle above the grass bag (Figure 6).

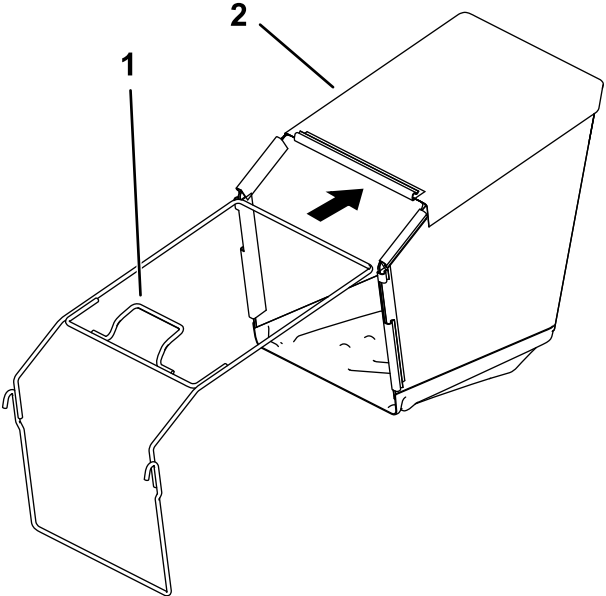

Figure 6

g281417

1. Frame handle
2. Grass bag

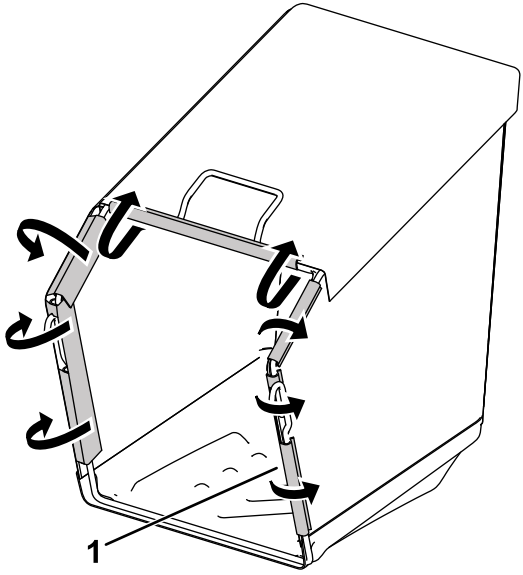

Figure 7

g281418

1. Plastic clips

3. Attach the plastic clips to the grass-bag frame (Figure 7).

3

Adding Oil to the Engine

No Parts Required

Procedure

Important: Your machine does not come with oil in the engine. Before starting the engine, fill the engine with oil.

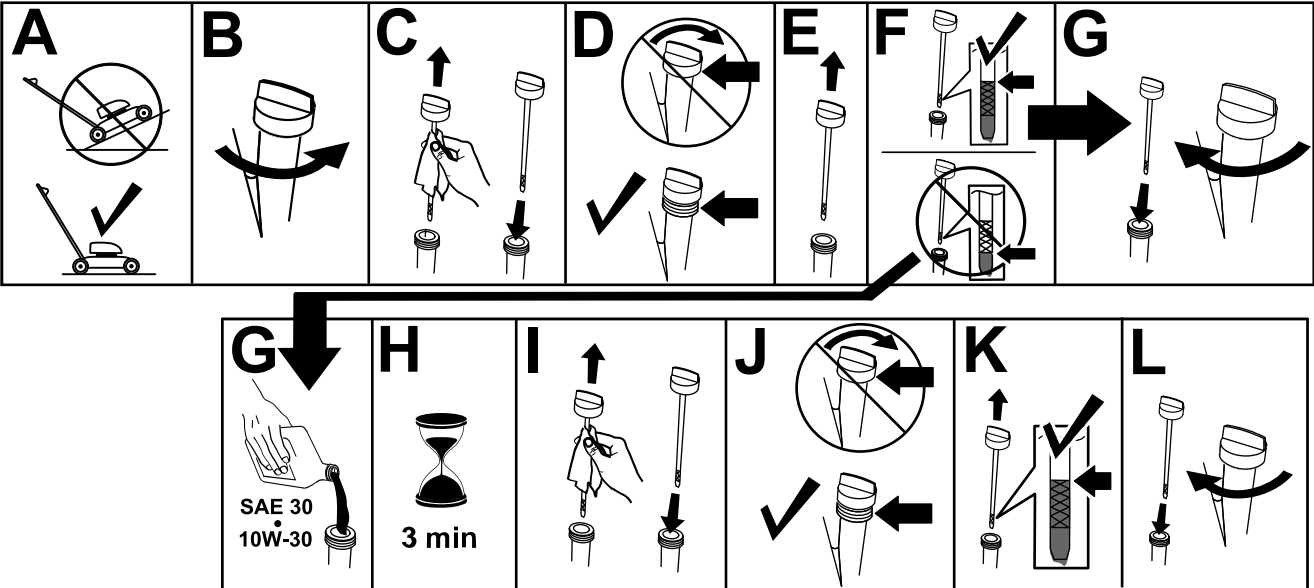

Figure 8

g235721

Product Overview

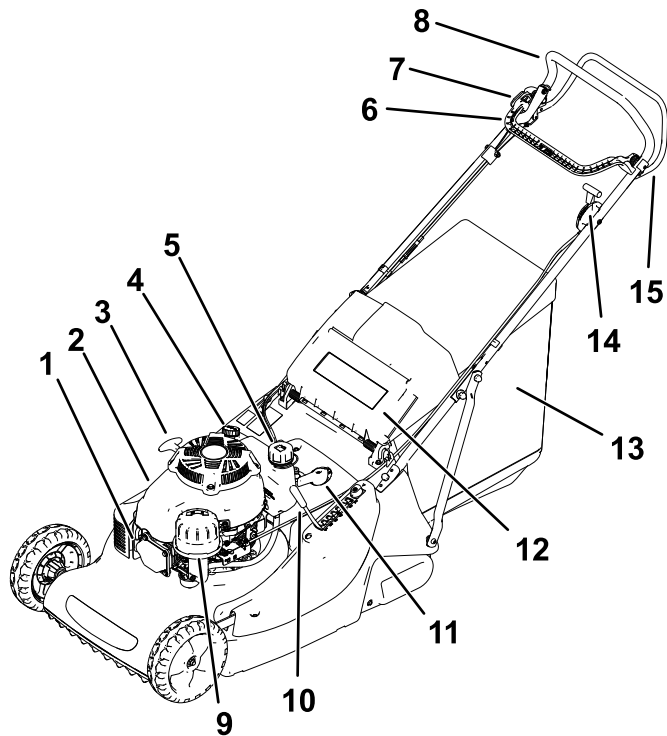

Figure 9

g281445

- | | |
|----------------------------|-----------------------------|
| 1. Spark-plug wire | 9. Air cleaner |
| 2. Engine cover | 10. Height-of-cut adjuster |
| 3. Recoil-start handle | 11. 3-speed gear selector |
| 4. Oil-filler cap/dipstick | 12. Rear deflector |
| 5. Fuel-filler cap | 13. Grass-bag assembly |
| 6. BBC control lever | 14. Engine-speed controller |
| 7. BBC latch button | 15. Self-propel-drive bar |
| 8. Handlebar | |

Specifications

Model	Weight	Length	Width	Height
02657	66 kg (145.5 lb)	175.5 cm (69.1 inches)	58.6 cm (23 inches)	103.9 cm 3.9 cm (40.9 inches)

Operation

Before Operation

Before Operation Safety

General Safety

- Always shut off the machine, wait for all moving parts to stop, and allow the machine to cool before adjusting, servicing, cleaning, or storing it.
- Become familiar with the safe operation of the equipment, operator controls, and safety signs.
- Check that all guards and safety devices, such as deflectors and/or grass catcher, are in place and functioning properly.
- Always inspect the machine to ensure that the blades and blade bolts are not worn or damaged.
- Inspect the area where you will use the machine, and remove all objects that could interfere with the operation of the machine or that the machine could throw.
- Contact with the moving blade will cause serious injury. Do not put your fingers under the housing.

Fuel Safety

- Fuel is extremely flammable and highly explosive. A fire or explosion from fuel can burn you and others and can damage property.
 - To prevent a static charge from igniting the fuel, place the container and/or machine directly on the ground before filling, not in a vehicle or on an object.
 - Fill the fuel tank outdoors, in an open area, when the engine is cold. Wipe up any fuel that spills.
 - Do not handle fuel when smoking or around an open flame or sparks.
 - Do not remove the fuel cap or add fuel to the tank while the engine is running or hot.
 - If you spill fuel, do not attempt to start the engine. Avoid creating a source of ignition until the fuel vapors have dissipated.
 - Store fuel in an approved container and keep it out of the reach of children.
- Fuel is harmful or fatal if swallowed. Long-term exposure to vapors can cause serious injury and illness.
 - Avoid prolonged breathing of vapors.
 - Keep your hands and face away from the nozzle and the fuel-tank opening.
 - Keep fuel away from your eyes and skin.

Filling the Fuel Tank

Type	Unleaded gasoline
Minimum octane rating	87 (US) or 91 (research octane; outside the US)
Ethanol	No more than 10% by volume
Methanol	None
MTBE (methyl tertiary butyl ether)	Less than 15% by volume
Oil	Do not add to the fuel

Use only clean, fresh (no more than 30 days old), fuel from a reputable source.

Important: To reduce starting problems, add fuel stabilizer/conditioner to fresh fuel as directed by the fuel-stabilizer/conditioner manufacturer.

Refer to your engine owner's manual for additional information.

Fill the fuel tank as shown in [Figure 10](#).

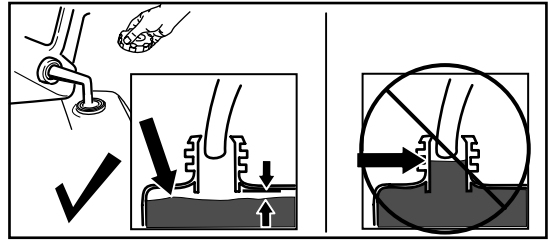

Figure 10

g230458

Checking the Engine-Oil Level

Service Interval: Before each use or daily

Important: If the oil level in the engine is too low or too high and you run the engine, you may damage the engine.

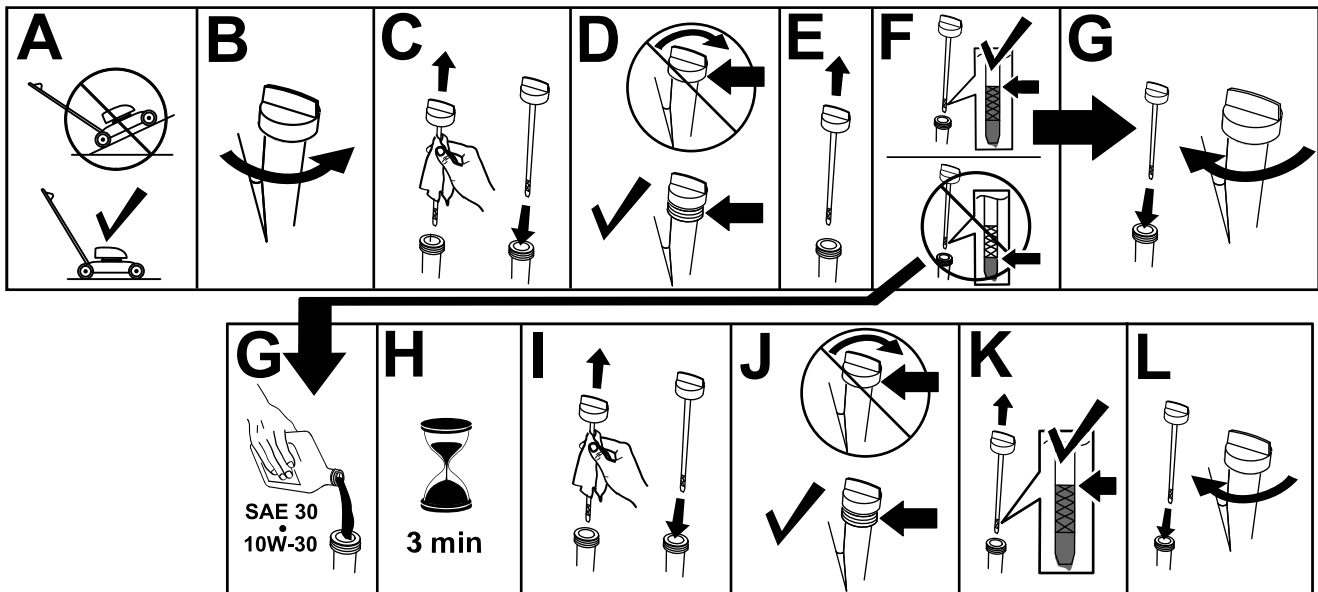

Figure 11

g235721

Adjusting the Cutting Height

⚠ DANGER

Adjusting the cutting height could bring your hands into contact with a moving blade and result in serious injury.

- Shut off the engine and wait for all moving parts to stop before adjusting the cutting height.
- Do not put your fingers under the housing when adjusting the cutting height.

⚠ CAUTION

If the engine has been running, the muffler will be hot and can severely burn you.

Keep away from the hot muffler.

Adjusting the Height of Cut

1. Grip the height-of-cut lever and pull sideways to disengage it from the locking notch (Figure 12).

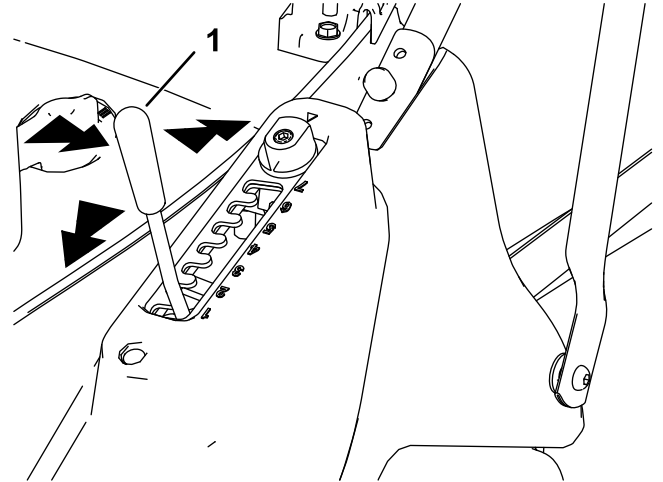

g281589

Figure 12

1. Height-of-cut adjusting lever

2. Push the lever forward to lower or pull it backward to raise the height of cut (Figure 12).
3. Release the lever at the required position and ensure that it locks firmly into 1 of the 7 setting notches (Figure 12).

Height Setting	Height of Cut
1	13.0 mm
2	20.8 mm
3	28.7 mm
4	36.5 mm
5	44.3 mm
6	52.2 mm
7	60.0 mm

Adjusting the Cutting Height Using Matchcut

An additional 6 setting heights can be achieved using the matchcut height setting. This feature allows the height of cut selector plate to adjust by one half setting.

1. Loosen the selector plate retaining bolt with an Allen wrench (Figure 13).

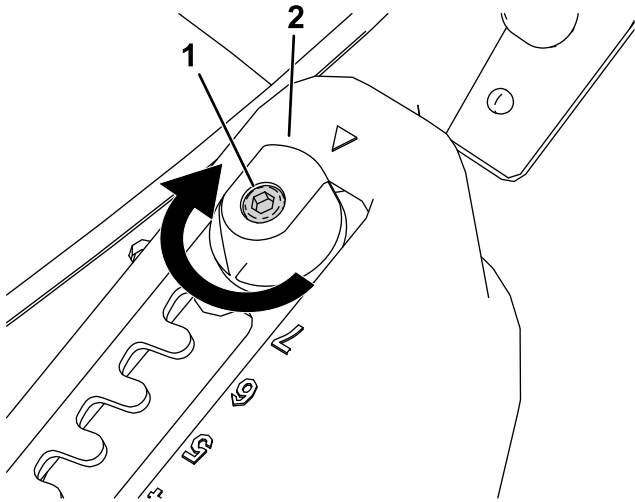

Figure 13

g281591

1. Retaining bolt
2. Matchcut adjuster

2. Turn the matchcut adjuster 180° (Figure 13 and Figure 14).

Note: An indicator will appear at the bottom of the selector plate, highlighting when matchcut is set.

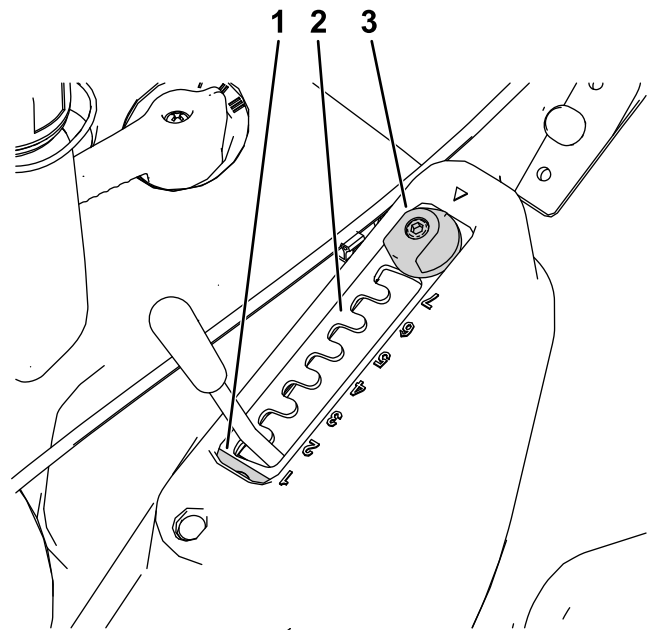

Figure 14

g281590

1. Matchcut indicator
2. Selector plate
3. Matchcut adjuster

3. Tighten the selector plate retaining bolt to fix the height of cut selector plate into position.

Height Setting (with Matchcut)	Height of Cut
1.5	16.9 mm
2.5	24.8 mm
3.5	32.6 mm
4.5	40.4 mm
5.5	48.3 mm
6.5	56.1 mm

Starting the Engine

1. Hold the handle and move the engine speed controller to the CHOKE position if the engine is cold, or to the FAST position if the engine has recently been running.

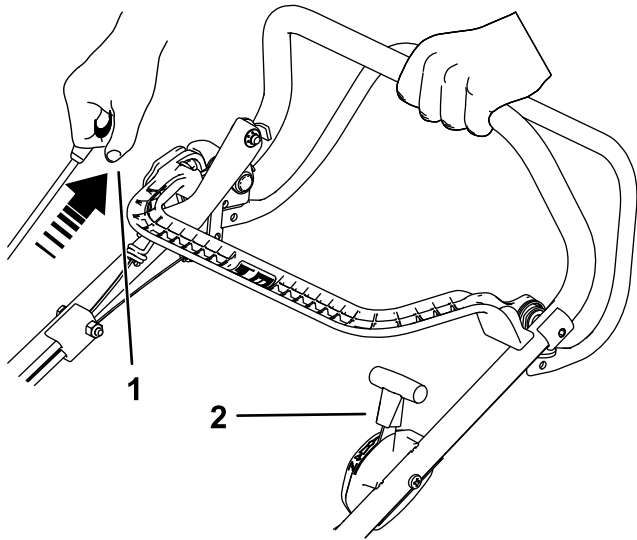

Figure 15

g281605

1. Pull the recoil-start handle. 2. Throttle control in the CHOKE position

2. Pull the recoil-start handle until you feel resistance, then pull sharply to start. When the engine starts, slowly return the throttle to the FAST position if the choke has been engaged (Figure 15).

Important: To prevent damage to the machine, do not pull the recoil start handle when the engine is running.

Note: If the machine does not start, contact an Authorized Service Dealer.

Note: The blade is not engaged at this stage; refer to [Engaging the Blade \(page 12\)](#).

Engaging the Blade

1. Ensure that the throttle control lever is in the FAST position (Figure 16).
2. Press the blade-brake clutch (BBC) latch button and pull the BBC control lever back against the handle (Figure 16).

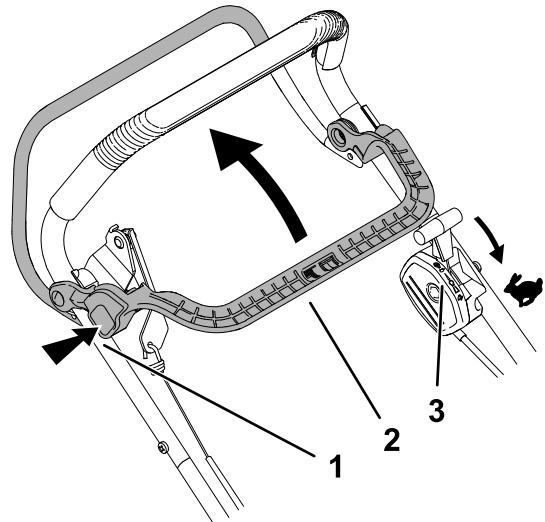

Figure 16

g284132

1. Press the BBC latch button. 3. Ensure that the throttle control lever is in the FAST position.
2. Pull the BBC control lever back against the handle.

Disengaging the Blade

Release the BBC control lever to disengage the blade; the handle will return to its rest position (Figure 17).

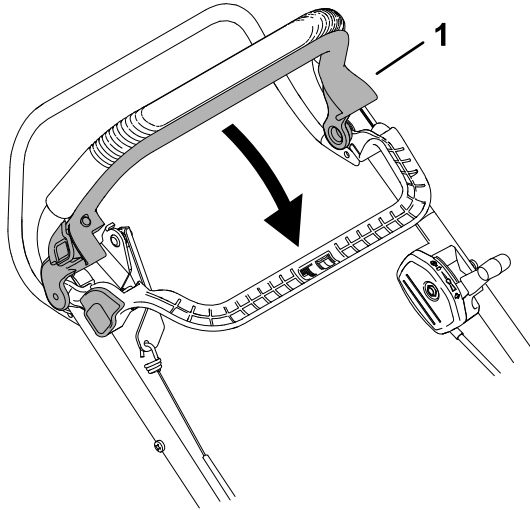

Figure 17

g284203

1. Release the BBC control lever to disengage the blade.

Note: When you release the BBC control lever, the blade should stop within 3 seconds. If it does not, stop using your mower immediately and contact your Authorized Service Dealer.

Selecting the Speed

The forward speed of the machine has 3 settings; rotate the 3-speed gear selector on the top of the mower to one of the three settings to adjust the speed.

- I – First gear
- II – Second gear
- III – Third gear

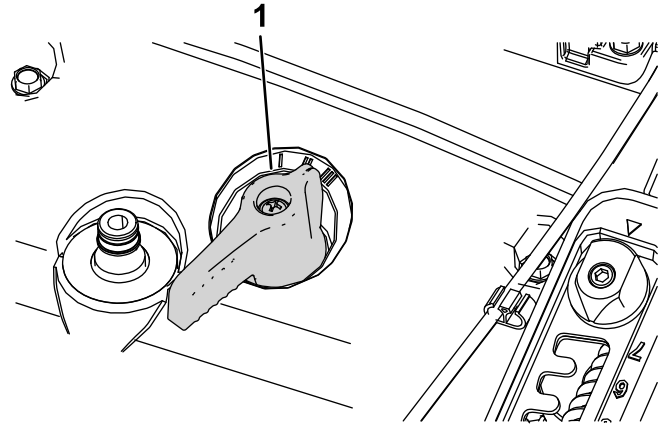

Figure 18

g283010

1. Speed-selection control

During Operation

During Operation Safety

General Safety

- Wear appropriate clothing, including eye protection; long pants; substantial, slip-resistant footwear; and hearing protection. Tie back long hair and do not wear loose clothing or loose jewelry.
- Use your full attention while operating the machine. Do not engage in any activity that causes distractions; otherwise, injury or property damage may occur.
- Do not operate the machine while ill, tired, or under the influence of alcohol or drugs.
- The blade is sharp; contacting the blade can result in serious personal injury. Shut off the engine and wait for all moving parts to stop before leaving the operating position.
- When you release the blade-control bar, the engine should shut off and the blade should stop within 3 seconds. If not, stop using your machine immediately and contact an Authorized Service Dealer.
- Keep bystanders out of the operating area. Keep small children out of the operating area and under the watchful care of a responsible adult who is not operating the machine. Stop the machine if anyone enters the area.
- Always look down and behind you before moving the machine in reverse.
- Operate the machine only in good visibility and appropriate weather conditions. Do not operate the machine when there is the risk of lightning.
- Wet grass or leaves can cause serious injury if you slip and contact the blade. Avoid mowing in wet conditions.
- Use extreme care when approaching blind corners, shrubs, trees, or other objects that may block your view.
- Do not direct the discharge material toward anyone. Avoid discharging material against a wall or obstruction; material may ricochet toward you. Stop the blade(s) when crossing gravel surfaces.
- Watch for holes, ruts, bumps, rocks, or other hidden objects. Uneven terrain could cause you to lose your balance or footing.
- If the machine strikes an object or starts to vibrate, immediately shut off the engine, wait for all moving parts to stop, and disconnect the wire

from the spark plug before examining the machine for damage. Make all necessary repairs before resuming operation.

- Before leaving the operating position, shut off the engine and wait for all moving parts to stop.
- If the engine has been running, it will be hot and can severely burn you. Keep away from the hot engine.
- Operate the engine only in well-ventilated areas. Exhaust gases contain carbon monoxide, which is an odorless, deadly poison.
- Check the grass catcher components and the discharge chute frequently for any wear or deterioration and replace them with genuine Toro parts when necessary.

Slope Safety

- Mow across the face of slopes; never up and down. Use extreme caution when changing direction on slopes.
- Do not mow on excessively steep slopes. Poor footing could cause a slip-and-fall accident.
- Mow with caution near drop-offs, ditches, or embankments.

Using the Self-Propel Drive

To operate the self-propel drive, squeeze the self-propel drive bar toward the handle and hold it in place (Figure 19).

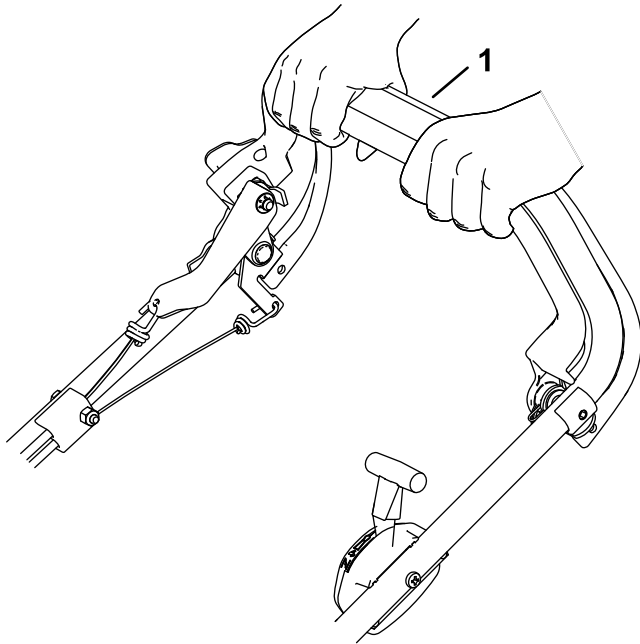

Figure 19

g282972

1. Self-propel-drive bar

To disengage the self-propel drive, release the self-propel-drive bar.

Shutting Off the Engine

Release the blade-brake clutch control and self-propel drive bars. Move the engine speed controller to the stop position to shut off the engine.

Important: When you release the blade control bar, the blade should stop within 3 seconds. If it does not stop properly, stop using your machine immediately and contact an Authorized Service Dealer.

Bagging the Clippings

Install the grass bag to collect grass and leaf clippings from the lawn.

⚠ WARNING

A worn grass bag could allow debris to be thrown and result in serious personal injury or death to the operator or bystanders.

Check the grass bag frequently. If it is damaged, install a new Toro replacement bag.

⚠ WARNING

The blade is sharp; contacting the blade can result in serious personal injury.

Shut off the engine and wait for all moving parts to stop before leaving the operating position.

1. Shut off the engine and wait for all moving parts to stop.
2. Raise and hold up the rear deflector.
3. Hook the grass bag into position (Figure 20).

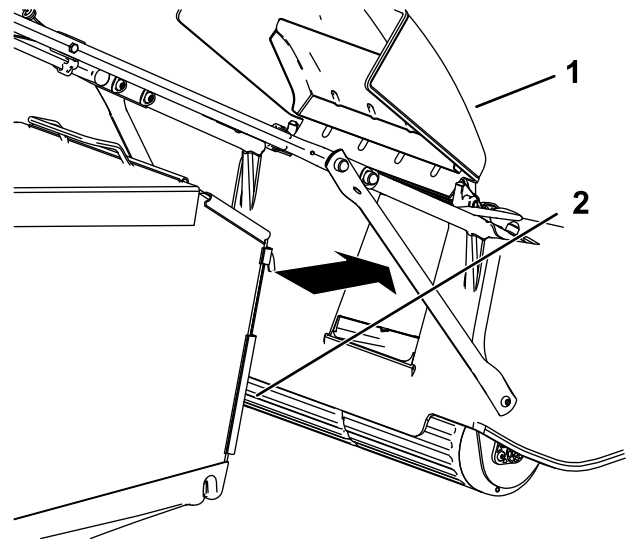

Figure 20

g283012

1. Rear deflector
2. Grass bag

4. Lower the rear deflector.

Operating Tips

General Mowing Tips

- Inspect the area where you will use the machine and remove all objects that the machine could throw.
- Avoid striking solid objects with the blade. Never deliberately mow over any object.
- If the machine strikes an object or starts to vibrate, immediately shut off the engine, wait for all moving parts to stop, disconnect the wire from the spark plug, and examine the machine for damage.
- For best performance, install a new Toro blade before the cutting season begins or when necessary.

Cutting Grass

- Cut only about a third of the grass blade at a time. Do not cut below 64 mm (2-1/2 inches) unless the grass is sparse or it is late fall when grass growth begins to slow down.
- When cutting grass over 15 cm (6 inches) tall, mow at the highest cutting height setting and walk slower; then mow again at a lower setting for the best lawn appearance. If the grass is too long, the machine may plug and cause the engine to stall.
- Wet grass and leaves tend to clump on the yard and can cause the machine to plug or the engine to stall. Avoid mowing in wet conditions.
- Be aware of a potential fire hazard in very dry conditions, follow all local fire warnings, and keep the machine free of dry grass and leaf debris.
- Alternate the mowing direction. This helps disperse the clippings over the lawn for even fertilization.
- If the finished lawn appearance is unsatisfactory, try 1 or more of the following:
 - Replace the blade or have it sharpened.
 - Walk at a slower pace while mowing.
 - Raise the cutting height on your machine.
 - Cut the grass more frequently.
 - Overlap cutting swaths instead of cutting a full swath with each pass.

Cutting Leaves

- After cutting the lawn, ensure that half of the lawn shows through the cut leaf cover. You may need to make more than a single pass over the leaves.

- If there are more than 13 cm (5 inches) of leaves on the lawn, mow at a higher cutting height and then again at the desired cutting height.
- Slow down your mowing speed if the machine does not cut the leaves finely enough.

After Operation

After Operation Safety

General Safety

- Always shut off the machine, wait for all moving parts to stop, and allow the machine to cool before adjusting, servicing, cleaning, or storing it.
- Clean grass and debris from the machine to help prevent fires. Clean up oil or fuel spills.
- Never store the machine or fuel container where there is an open flame, spark, or pilot light, such as on a water heater or on other appliances.

Hauling Safety

- Use care when loading or unloading the machine.
- Secure the machine from rolling.

Cleaning the Machine

Service Interval: After each use

⚠ WARNING

The machine may dislodge material from under the machine housing.

- **Wear eye protection.**
- **Stay in the operating position (behind the handle) when the engine is running.**
- **Do not allow bystanders in the area.**

For best results, clean the machine soon after you have completed mowing.

Important: Thoroughly clean the machine deck immediately after use on treated grass.

Note: Do not spray the engine with water during cleaning.

1. Move the machine onto a flat paved surface.
2. Shut off the engine and wait for all moving parts to stop before leaving the operating position.
3. Remove grass debris from the top of the deck housing immediately after use.
4. Remove all grass and debris from the engine including the exhaust/exhaust guard, the airways in the top cowl, and the surrounding deck using a brush or compressed air.
5. Lower the machine to its lowest cutting-height setting; refer to [Adjusting the Height of Cut \(page 10\)](#).

6. Wash out the area under the rear door where the clippings go from the underside of the machine to the grass bag.
7. Attach a garden hose that is connected to a water supply to the washout port ([Figure 21](#)).

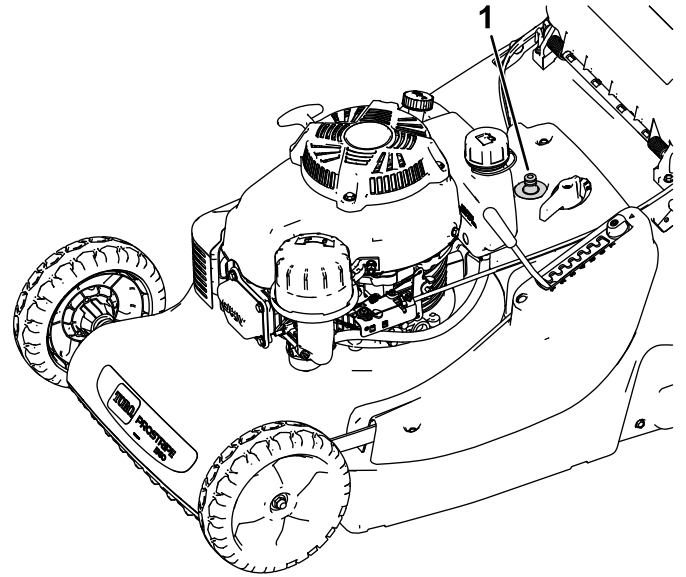

Figure 21

g281628

1. Washout port

8. Turn the water on, start the engine, engage the blade and run it until the clippings no longer come out from under the machine.
9. Shut off the engine, shut off the water, and disconnect the garden hose from the machine.
10. Start the engine and run it for a few minutes to dry the underside of the machine to prevent it from rusting.
11. Shut off the engine and allow the machine to cool before storing it in an enclosed area.
12. Clean up any spilled oil or fuel.

Maintenance

Note: Determine the left and right sides of the machine from the normal operating position.

Recommended Maintenance Schedule(s)

Maintenance Service Interval	Maintenance Procedure
After the first 8 hours	<ul style="list-style-type: none"> Change the engine oil.
Before each use or daily	<ul style="list-style-type: none"> Check the engine-oil level. Ensure that the engine shuts off within 3 seconds after releasing the blade control bar. Check the condition of the blade. Ensure that the guards and safety devices are in place and working correctly. Ensure that the deck is clear and that the grass bag is in good condition (replace if it is damaged).
After each use	<ul style="list-style-type: none"> Clean grass clippings and dirt from under the machine.
Every 25 hours	<ul style="list-style-type: none"> Clean the foam pre-filter (more frequently in dusty conditions). Check the self-propel cable and adjust if needed. Replace the blade or have it sharpened (more frequently if the edge dulls quickly). Sharpen the blade.
Every 50 hours	<ul style="list-style-type: none"> Change the engine oil (more frequently in dusty conditions).
Every 100 hours	<ul style="list-style-type: none"> Replace the spark plug.
Every 300 hours	<ul style="list-style-type: none"> Replace the paper air filter (more frequently in dusty conditions).
Before storage	<ul style="list-style-type: none"> Empty the fuel tank before repairs as directed and before yearly storage.
Yearly	<ul style="list-style-type: none"> Replace the blade or have it sharpened. Refer to your engine owner's manual for any additional yearly maintenance procedures.

Important: Refer to your engine owner's manual for additional maintenance procedures.

Maintenance Safety

- Always shut off the machine, wait for all moving parts to stop, and allow the machine to cool before adjusting, servicing, cleaning, or storing it.
- Disconnect the spark-plug wire from the spark plug before performing any maintenance procedure.
- Wear gloves and eye protection when servicing the machine.
- The blade is sharp; contacting the blade can result in serious personal injury. Wear gloves when servicing the blade. Do not repair or alter the blade(s).
- Never tamper with safety devices. Check their proper operation regularly.
- Tipping the machine may cause the fuel to leak. Fuel is flammable and explosive, and can cause

personal injury. Run the engine dry or remove the fuel with a hand pump; never siphon the fuel.

- To ensure optimum performance of the machine, use only genuine Toro replacement parts and accessories. Replacement parts and accessories made by other manufacturers could be dangerous, and such use could void the product warranty.

Preparing for Maintenance

Service Interval: Every 100 hours

- Shut off the engine and wait for all moving parts to stop.
- Disconnect the spark-plug wire from the spark plug (Figure 22) before performing any maintenance procedure.

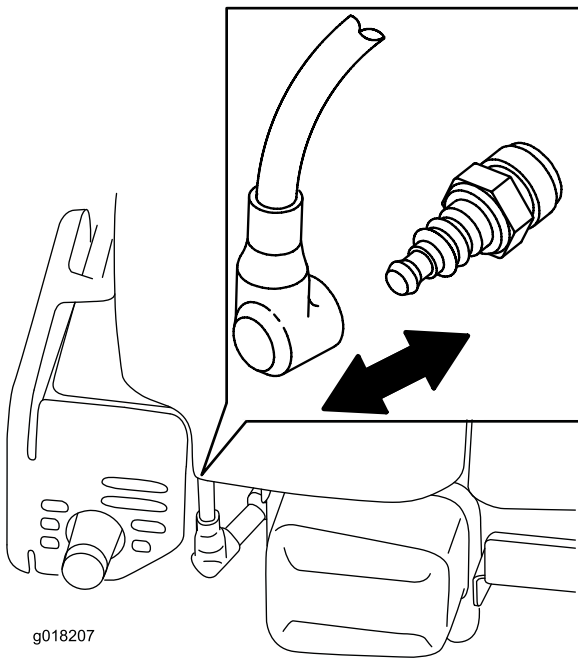

g018207

g018207

Figure 22

3. After performing the maintenance procedure(s), connect the spark-plug wire to the spark plug.

Important: Before tipping the machine to change the oil or replace the blade, allow the fuel tank to run dry through normal use. If you must tip the machine prior to running out of fuel, use a hand fuel pump to remove the fuel. Always tip the machine onto its side with the air filter up.

⚠ WARNING

Tipping the machine may cause the fuel to leak. Fuel is flammable, explosive, and can cause personal injury.

Run the engine dry or remove the gasoline with a hand pump; do not siphon.

Servicing the Air Filter

Service Interval: Every 25 hours—Clean the foam pre-filter (more frequently in dusty conditions).

Every 300 hours—Replace the paper air filter (more frequently in dusty conditions).

Important: Do not operate the engine without the air filter assembly in place; otherwise, extreme engine damage will occur.

1. Perform the pre-maintenance procedures; refer to [Preparing for Maintenance \(page 18\)](#).
2. Remove the cover and clean it thoroughly ([Figure 23](#)).

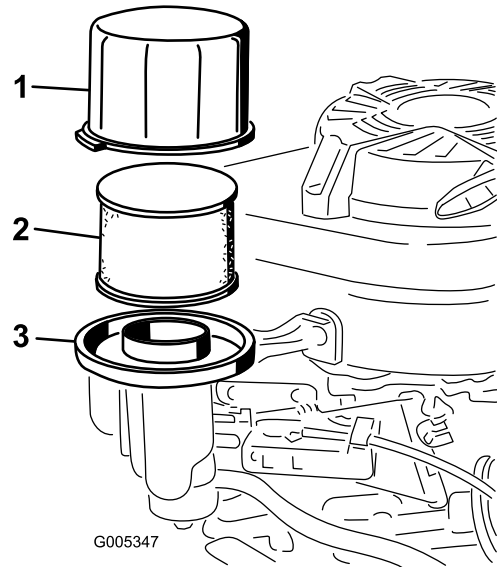

G005347

g005347

Figure 23

1. Cover
2. Foam pre-filter and paper air filter
3. Air-filter base

3. Remove and the foam pre-filter and the paper-air filter from the air-filter base ([Figure 23](#)).
4. Remove the foam pre-filter from the paper air filter, and wash the foam pre-filter with a mild detergent and water, then blot it dry.
5. Inspect the paper air filter, and replace it if it is excessively dirty.

Important: Do not try to clean a paper filter.

6. Install the foam pre-filter onto the paper air filter.
7. Install the foam pre-filter and paper air filter onto the air-filter base.
8. Install the cover.

Changing the Engine Oil

Service Interval: After the first 8 hours

Every 50 hours

Run the engine a few minutes before changing the oil to warm it. Warm oil flows better and carries more contaminants.

Engine Oil Specifications

Engine oil capacity	0.65 L (22 fl oz)* without oil filter; 0.85 L (29 fl oz)* with oil filter
Oil viscosity	SAE 30 or SAE 10W-30 detergent oil
API service classification	SJ or higher

*There is residual oil in the crankcase after you drain the oil. Do not pour the entire capacity of oil into the crankcase. Fill the crankcase with oil as directed in the following steps.

1. Perform the pre-maintenance procedures; refer to [Preparing for Maintenance \(page 18\)](#).
2. Drain the fuel from the fuel tank.
3. Place a suitable drain pan under the dipstick/oil drain.
4. Clean around the dipstick.
5. Remove the dipstick by rotating the cap counterclockwise and pulling it out.
6. Tip the machine onto its **right** side (air filter up) to drain the oil into the drain pan.
7. After draining the oil, return the machine to the operating position.
8. Carefully pour about 3/4 of the engine capacity of oil into the oil-fill tube.
9. Wait 3 minutes for the oil to settle in the engine.
10. Wipe the dipstick clean with a clean cloth.
11. Insert the dipstick into the oil-fill tube, **do not** screw it in, then remove the dipstick.
12. Read the oil level on the dipstick.
 - If the oil level on the dipstick is too low, carefully pour a small amount of oil into the oil-fill tube, wait 3 minutes, and repeat steps [10](#) through [12](#) until the oil level on the dipstick is correct.
 - If the oil level on the dipstick is too high, drain the excess oil until the oil level on the dipstick is correct.
13. Install the dipstick into the oil-fill tube securely.

Important: If the oil level in the engine is too low or too high and you run the engine, you may damage the engine.

14. Recycle the used oil properly.

Adjusting the Self-Propel Cable

Service Interval: Every 25 hours

1. Shut off the engine.
2. Pull the machine backward while slowly engaging the self-propel bar until the rear rollers lock.

Note: The self-propel bar should now be 6 cm (2-3/8 inches) from the handlebar.

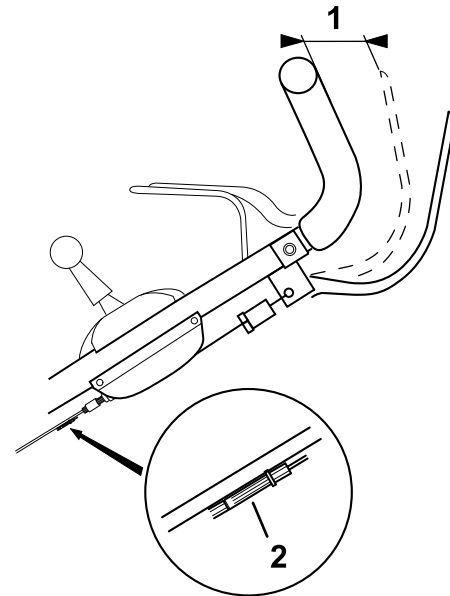

Figure 24

g283011

1. 6 cm (2-3/8 inches)
2. Cable adjuster

3. If the distance between the self-propel bar and the handlebar is less than 6 cm (2-3/8 inches), adjust the black plastic cable adjuster to set the correct distance.

Replacing the Blade

Service Interval: Every 25 hours—Replace the blade or have it sharpened (more frequently if the edge dulls quickly).

Yearly

Important: You will need a torque wrench to install the blade properly. If you do not have a torque wrench or are uncomfortable performing this procedure, contact an Authorized Service Dealer.

Examine the blade whenever you run out of fuel. If the blade is damaged or cracked, replace it immediately. If the blade edge is dull or nicked, have it sharpened and balanced, or replace it.

⚠ WARNING

The blade is sharp; contacting the blade can result in serious personal injury.

Wear gloves when servicing the blade.

1. Disconnect the spark-plug wire from the spark plug; refer to [Preparing for Maintenance \(page 18\)](#).
2. Tip the machine onto its side with the air filter up.
3. Use a block of wood to hold the blade steady ([Figure 25](#)).

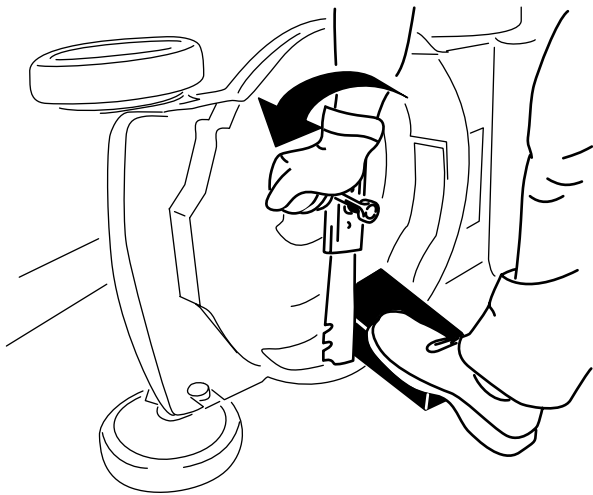

Figure 25

g231389

4. Remove the blade, saving all mounting hardware ([Figure 25](#)).
5. Install the new blade and all mounting hardware ([Figure 26](#)).

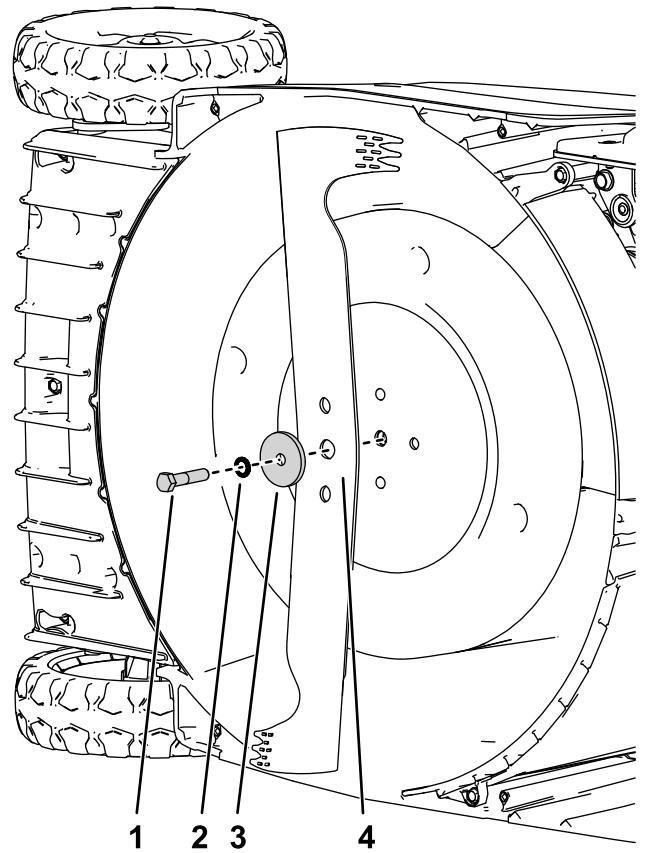

Figure 26

g338891

- | | |
|----------------|-----------|
| 1. Bolt | 3. Spacer |
| 2. Lock washer | 4. Blade |

Important: Position the curved ends of the blade to point toward the machine housing.

6. Use a torque wrench to tighten the blade bolt to 54 N·m (40 ft·lb).

Sharpening the Blade

Service Interval: Before each use or daily
Every 25 hours

A slightly worn blade may be re-sharpened. Both blade edges must be sharpened equally to ensure balance.

1. Remove the blade from the machine; refer to [Replacing the Blade \(page 21\)](#).
2. Clean the blade using a brush and water, then inspect the blade for signs of damage.
3. Sharpen both cutting edges with a flat file.

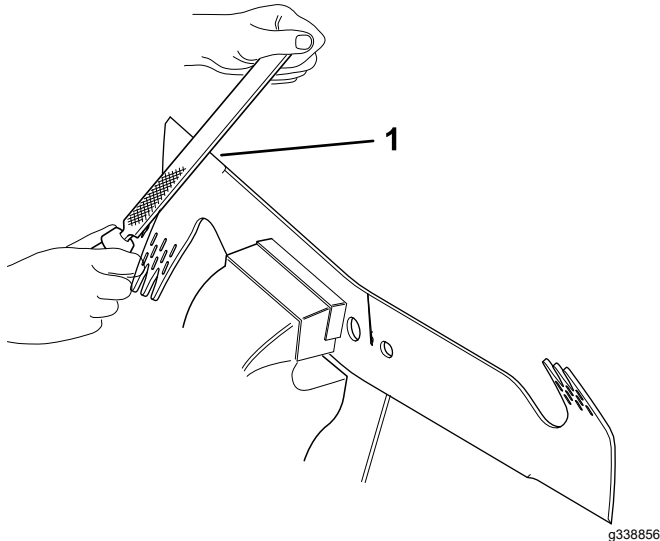

Figure 27

1. File from 30° to 45° degrees

4. Slide a screwdriver through the center hole and hold the blade horizontal.

Note: A balanced blade will remain horizontal.

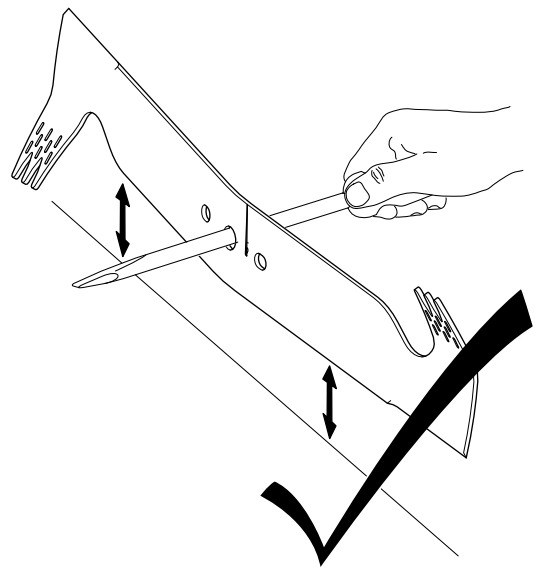

Figure 28

g338857

5. Sharpen the heavy end until the blade is correctly balanced.

Note: If the blade is not balanced, the heavy end will rotate down.

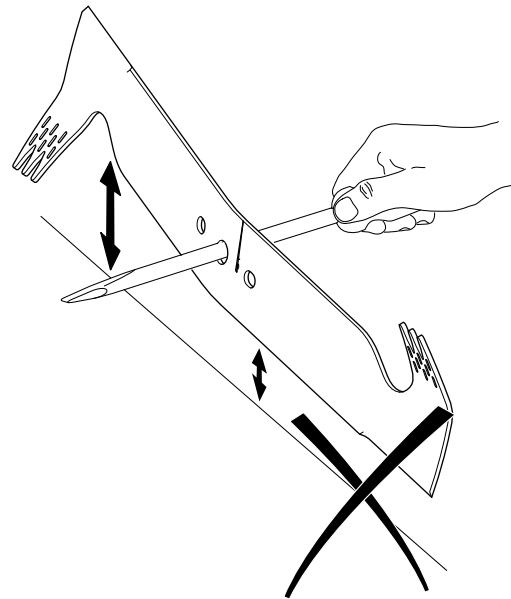

Figure 29

g338858

Storage

Store the machine in a cool, clean, dry place.

4. Fill the fuel tank with fresh fuel; refer to [Filling the Fuel Tank \(page 9\)](#).
5. Connect the wire to the spark plug.

Storage Safety

Always shut off the machine, wait for all moving parts to stop, and allow the machine to cool before adjusting, servicing, cleaning, or storing it.

Preparing the Machine for Storage

1. On the last refueling of the year, add fuel stabilizer (such as Toro Premium Fuel Treatment) to the fuel as directed on the label.
2. Dispose of any unused fuel properly. Recycle it according to local codes or use it in your automobile.

***Important:* Old fuel in the fuel tank is the leading cause of hard starting. Do not store the fuel without fuel stabilizer more than 30 days, and do not store stabilized fuel beyond the duration recommended by the fuel-stabilizer manufacturer.**

3. Run the machine until the engine shuts off from running out of fuel.
4. Start the engine again and allow it to run until it shuts off. When you can no longer start the engine, it is sufficiently dry.
5. Disconnect the wire from the spark plug and connect the wire to the retaining post (if equipped).
6. Remove the spark plug, add 15 ml (0.5 oz) of engine oil through the spark-plug hole, and pull the starter rope slowly several times to distribute oil throughout the cylinder to prevent cylinder corrosion during the off-season.
7. Install the spark plug and tighten it with a torque wrench to 23 N·m (17 ft-lb).
8. Tighten all nuts, bolts, and screws.

Removing the Machine from Storage

1. Check and tighten all fasteners.
2. Perform any maintenance procedures; refer to [Maintenance \(page 18\)](#).
3. Check the engine-oil level; refer to [Checking the Engine-Oil Level \(page 9\)](#).

Notes:

Notes:

EEA/UK Privacy Notice

Toro's Use of Your Personal Information

The Toro Company ("Toro") respects your privacy. When you purchase our products, we may collect certain personal information about you, either directly from you or through your local Toro company or dealer. Toro uses this information to fulfil contractual obligations - such as to register your warranty, process your warranty claim or to contact you in the event of a product recall - and for legitimate business purposes - such as to gauge customer satisfaction, improve our products or provide you with product information which may be of interest. Toro may share your information with our subsidiaries, affiliates, dealers or other business partners in connection these activities. We may also disclose personal information when required by law or in connection with the sale, purchase or merger of a business. We will never sell your personal information to any other company for marketing purposes.

Retention of your Personal Information

Toro will keep your personal information as long as it is relevant for the above purposes and in accordance with legal requirements. For more information about applicable retention periods please contact legal@toro.com.

Toro's Commitment to Security

Your personal information may be processed in the US or another country which may have less strict data protection laws than your country of residence. Whenever we transfer your information outside of your country of residence, we will take legally required steps to ensure that appropriate safeguards are in place to protect your information and to make sure it is treated securely.

Access and Correction

You may have the right to correct or review your personal data, or object to or restrict the processing of your data. To do so, please contact us by email at legal@toro.com. If you have concerns about the way in which Toro has handled your information, we encourage you to raise this directly with us. Please note that European residents have the right to complain to your Data Protection Authority.

California Proposition 65 Warning Information

What is this warning?

You may see a product for sale that has a warning label like the following:



WARNING: Cancer and Reproductive Harm—www.p65Warnings.ca.gov.

What is Prop 65?

Prop 65 applies to any company operating in California, selling products in California, or manufacturing products that may be sold in or brought into California. It mandates that the Governor of California maintain and publish a list of chemicals known to cause cancer, birth defects, and/or other reproductive harm. The list, which is updated annually, includes hundreds of chemicals found in many everyday items. The purpose of Prop 65 is to inform the public about exposure to these chemicals.

Prop 65 does not ban the sale of products containing these chemicals but instead requires warnings on any product, product packaging, or literature with the product. Moreover, a Prop 65 warning does not mean that a product is in violation of any product safety standards or requirements. In fact, the California government has clarified that a Prop 65 warning "is not the same as a regulatory decision that a product is 'safe' or 'unsafe.'" Many of these chemicals have been used in everyday products for years without documented harm. For more information, go to <https://oag.ca.gov/prop65/faqs-view-all>.

A Prop 65 warning means that a company has either (1) evaluated the exposure and has concluded that it exceeds the "no significant risk level"; or (2) has chosen to provide a warning based on its understanding about the presence of a listed chemical without attempting to evaluate the exposure.

Does this law apply everywhere?

Prop 65 warnings are required under California law only. These warnings are seen throughout California in a wide range of settings, including but not limited to restaurants, grocery stores, hotels, schools, and hospitals, and on a wide variety of products. Additionally, some online and mail order retailers provide Prop 65 warnings on their websites or in catalogs.

How do the California warnings compare to federal limits?

Prop 65 standards are often more stringent than federal and international standards. There are various substances that require a Prop 65 warning at levels that are far lower than federal action limits. For example, the Prop 65 standard for warnings for lead is 0.5 µg/day, which is well below the federal and international standards.

Why don't all similar products carry the warning?

- Products sold in California require Prop 65 labelling while similar products sold elsewhere do not.
- A company involved in a Prop 65 lawsuit reaching a settlement may be required to use Prop 65 warnings for its products, but other companies making similar products may have no such requirement.
- The enforcement of Prop 65 is inconsistent.
- Companies may elect not to provide warnings because they conclude that they are not required to do so under Prop 65; a lack of warnings for a product does not mean that the product is free of listed chemicals at similar levels.

Why does Toro include this warning?

Toro has chosen to provide consumers with as much information as possible so that they can make informed decisions about the products they buy and use. Toro provides warnings in certain cases based on its knowledge of the presence of one or more listed chemicals without evaluating the level of exposure, as not all the listed chemicals provide exposure limit requirements. While the exposure from Toro products may be negligible or well within the "no significant risk" range, out of an abundance of caution, Toro has elected to provide the Prop 65 warnings. Moreover, if Toro does not provide these warnings, it could be sued by the State of California or by private parties seeking to enforce Prop 65 and subject to substantial penalties.



The Toro Warranty

Two-Year or 1,500 Hours Limited Warranty

Conditions and Products Covered

The Toro Company and its affiliate, Toro Warranty Company, pursuant to an agreement between them, jointly warrant your Toro Commercial product ("Product") to be free from defects in materials or workmanship for 2 years or 1,500 operational hours*, whichever occurs first. This warranty is applicable to all products with the exception of Aerators (refer to separate warranty statements for these products). Where a warrantable condition exists, we will repair the Product at no cost to you including diagnostics, labor, parts, and transportation. This warranty begins on the date the Product is delivered to the original retail purchaser.

* Product equipped with an hour meter.

Instructions for Obtaining Warranty Service

You are responsible for notifying the Commercial Products Distributor or Authorized Commercial Products Dealer from whom you purchased the Product as soon as you believe a warrantable condition exists. If you need help locating a Commercial Products Distributor or Authorized Dealer, or if you have questions regarding your warranty rights or responsibilities, you may contact us at:

Toro Commercial Products Service Department
Toro Warranty Company
8111 Lyndale Avenue South
Bloomington, MN 55420-1196
952-888-8801 or 800-952-2740
E-mail: commercial.warranty@toro.com

Owner Responsibilities

As the product owner, you are responsible for required maintenance and adjustments stated in your *Operator's Manual*. Repairs for product issues caused by failure to perform required maintenance and adjustments are not covered under this warranty.

Items and Conditions Not Covered

Not all product failures or malfunctions that occur during the warranty period are defects in materials or workmanship. This warranty does not cover the following:

- Product failures which result from the use of non-Toro replacement parts, or from installation and use of add-on, or modified non-Toro branded accessories and products.
- Product failures which result from failure to perform recommended maintenance and/or adjustments.
- Product failures which result from operating the Product in an abusive, negligent, or reckless manner.
- Parts consumed through use that are not defective. Examples of parts which are consumed, or used up, during normal Product operation include, but are not limited to, brake pads and linings, clutch linings, blades, reels, rollers and bearings (sealed or greasable), bed knives, spark plugs, castor wheels and bearings, tires, filters, belts, and certain sprayer components such as diaphragms, nozzles, flow meters, and check valves.
- Failures caused by outside influence, including, but not limited to, weather, storage practices, contamination, use of unapproved fuels, coolants, lubricants, additives, fertilizers, water, or chemicals.
- Failure or performance issues due to the use of fuels (e.g. gasoline, diesel, or biodiesel) that do not conform to their respective industry standards.
- Normal noise, vibration, wear and tear, and deterioration. Normal "wear and tear" includes, but is not limited to, damage to seats due to wear or abrasion, worn painted surfaces, scratched decals or windows.

Countries Other than the United States or Canada

Customers who have purchased Toro products exported from the United States or Canada should contact their Toro Distributor (Dealer) to obtain guarantee policies for your country, province, or state. If for any reason you are dissatisfied with your Distributor's service or have difficulty obtaining guarantee information, contact your Authorized Toro Service Center.

Parts

Parts scheduled for replacement as required maintenance are warranted for the period of time up to the scheduled replacement time for that part. Parts replaced under this warranty are covered for the duration of the original product warranty and become the property of Toro. Toro will make the final decision whether to repair any existing part or assembly or replace it. Toro may use remanufactured parts for warranty repairs.

Deep Cycle and Lithium-Ion Battery Warranty

Deep cycle and Lithium-Ion batteries have a specified total number of kilowatt-hours they can deliver during their lifetime. Operating, recharging, and maintenance techniques can extend or reduce total battery life. As the batteries in this product are consumed, the amount of useful work between charging intervals will slowly decrease until the battery is completely worn out. Replacement of worn out batteries, due to normal consumption, is the responsibility of the product owner. Note: (Lithium-Ion battery only): Refer to the battery warranty for additional information.

Lifetime Crankshaft Warranty (ProStripe 02657 Model Only)

The ProStripe which is fitted with a genuine Toro Friction Disc and Crank-Safe Blade Brake Clutch (integrated Blade Brake Clutch (BBC) + Friction Disc assembly) as original equipment and used by the original purchaser in accordance with recommended operating and maintenance procedures, are covered by a Lifetime Warranty against engine crankshaft bending. Machines fitted with friction washers, Blade Brake Clutch (BBC) units and other such devices are not covered by the Lifetime Crankshaft Warranty.

Maintenance is at Owner's Expense

Engine tune-up, lubrication, cleaning and polishing, replacement of filters, coolant, and completing recommended maintenance are some of the normal services Toro products require that are at the owner's expense.

General Conditions

Repair by an Authorized Toro Distributor or Dealer is your sole remedy under this warranty.

Neither The Toro Company nor Toro Warranty Company is liable for indirect, incidental or consequential damages in connection with the use of the Toro Products covered by this warranty, including any cost or expense of providing substitute equipment or service during reasonable periods of malfunction or non-use pending completion of repairs under this warranty. Except for the Emissions warranty referenced below, if applicable, there is no other express warranty. All implied warranties of merchantability and fitness for use are limited to the duration of this express warranty.

Some states do not allow exclusions of incidental or consequential damages, or limitations on how long an implied warranty lasts, so the above exclusions and limitations may not apply to you. This warranty gives you specific legal rights, and you may also have other rights which vary from state to state.

Note Regarding Emissions Warranty

The Emissions Control System on your Product may be covered by a separate warranty meeting requirements established by the U.S. Environmental Protection Agency (EPA) and/or the California Air Resources Board (CARB). The hour limitations set forth above do not apply to the Emissions Control System Warranty. Refer to the Engine Emission Control Warranty Statement supplied with your product or contained in the engine manufacturer's documentation.