



## Weight Kit

Groundsmaster® 3200 or 3300 Series Traction Unit

Model No. 144-0480

### Installation Instructions

## Installation

# 1

### Preparing the Machine

No Parts Required

#### Procedure

1. Park the machine on a level surface.
2. Engage the parking brake.
3. Lower the cutting unit.
4. Shut off the engine and remove the key.

# 2

### Installing the Kit

Parts needed for this procedure:

1	Weight bracket
2	Weight
2	Carriage bolt
4	Hex-head bolt
6	Nut

#### Procedure

1. Use 4 hex-head bolts to secure the weight bracket to the bumper (Figure 1).

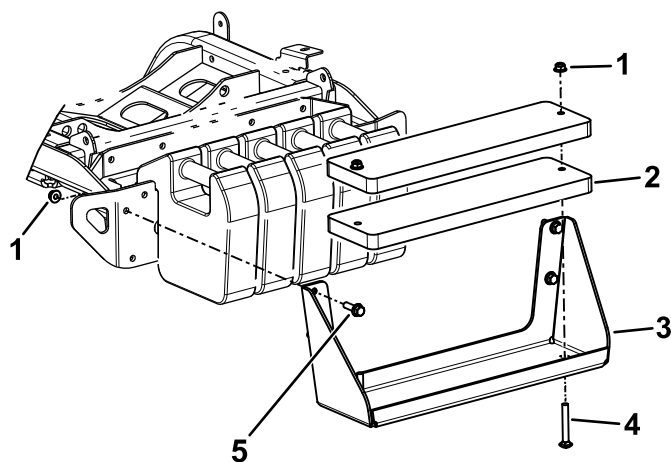

Figure 1

g330590

- |                   |                  |
|-------------------|------------------|
| 1. Nut            | 4. Carriage bolt |
| 2. Weight         | 5. Hex-head bolt |
| 3. Weight bracket |                  |

2. Use 2 carriage bolts and 2 nuts to secure the weights to the weight bracket (Figure 1).

**Note:** Certain traction-unit and attachment combinations require you to install a third weight. Refer to your traction-unit *Operator's Manual* for more information.

