



Model No. 44225—90001 & Up  
 Model No. 44225—200000001 & Up

**OPERATOR'S  
 MANUAL**

**Top Dresser 1800**  
 Attachment for Workman 3000/4000 Series

To assure maximum safety, optimum performance, and to gain knowledge of the product, it is essential that you or any other operator of the machine read and understand the contents of this manual before the engine is ever started. Pay particular attention to the **SAFETY INSTRUCTIONS** highlighted by this symbol —

The safety alert symbol means **CAUTION, WARNING** or **DANGER** — personal safety instruction. Failure to comply with the instruction may result in personal injury.



# FOREWORD

The Topdresser 1800 has advanced concepts in engineering, design and safety; and if maintained properly, will give excellent service.

Since this is a high-quality product, Toro is concerned about the future use of the machine and safety of the user. Therefore, read this manual to familiarize yourself with proper set-up, operation and maintenance instructions. The major sections of the manual are:

- |                        |                     |                |
|------------------------|---------------------|----------------|
| 1. Safety Instructions | 3. Before Operating | 5. Maintenance |
| 2. Set-up Instructions | 4. Lubrication      |                |

Certain information in this manual is emphasized. DANGER, WARNING and CAUTION identify personal safety related information. IMPORTANT identifies mechanical information demanding special attention. Be sure to read this directive because it deals with the possibility of damaging a part or parts of the machine. NOTE identifies general information worthy of special attention.

## TABLE OF CONTENTS

	Page		Page
<b>SAFETY INSTRUCTIONS</b> .....	3-4	Sand Precautions .....	12
<b>SAFETY AND INSTRUCTION DECALS</b> .....	5	Cold Weather Operation .....	12
<b>SPECIFICATIONS</b> .....	6	<b>LUBRICATION</b> .....	12
<b>LOOSE PARTS</b> .....	6	Grease Bearings .....	12
<b>SET-UP INSTRUCTIONS</b> .....	7-10	<b>MAINTENANCE</b> .....	13-17
Remove 2/3 or Full Size Bed .....	7	Brush Adjustment .....	13
Mount Topdresser .....	7	Drive Chain Tension .....	13
Connect Cylinders .....	8	Adjusting Conveyor Belt .....	14
Safety Support .....	9	Replacing Conveyor Belt .....	14
Connect Hydraulic Couplers .....	9	<b>TROUBLE SHOOTING</b> .....	17
<b>CONTROLS</b> .....	10	<b>HYDRAULIC SCHEMATIC</b> .....	18
Gate Metering Control .....	10	<b>SEASONAL STORAGE</b> .....	19
Rate Scale .....	10	<b>IDENTIFICATION AND ORDERING</b> .....	19
<b>OPERATING INSTRUCTIONS</b> .....	11	<b>WARRANTY</b> .....	Back Cover
Sand Application Rate .....	11		

# SAFETY INSTRUCTIONS

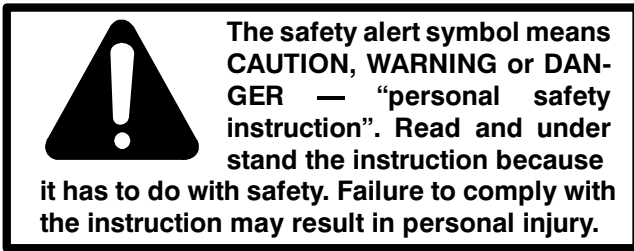

## BEFORE OPERATING

1. Read and understand the contents of this Operator’s Manual before operating the machine. Become familiar with all controls and know how to stop quickly. A free replacement manual is available by sending complete Model and Serial Number to:

The Toro Company  
8111 Lyndale Avenue South  
Bloomington, Minnesota 55420-1196

2. Never allow children to operate the machine. Do not allow adults to operate the machine without proper instructions. Only trained and authorized persons should operate this vehicle. Anyone who operates the vehicle should have a motor vehicle license.

3. Never operate the machine when under the influence of drugs or alcohol.

4. Keep all shields and safety devices in place. If a shield, safety device or decal is illegible or damaged, repair or replace it before operation is commenced.

**NOTE:** The front 1/3 area of the Workman cargo zone must be covered by a 1/3 attachment or shield when using the Topdresser 1800.

5. Tighten any loose nuts, bolts and screws to assure machine is in safe operating condition. Make sure Topdresser mounting pins, pivot pins and hydraulic cylinder pins are in place and secure.

6. Do not modify this equipment in any manner.

7. Do not operate machine while wearing sandals, tennis shoes, sneakers or shorts. Also, do not wear loose fitting clothing which could get caught in moving parts. Always wear long pants and substantial shoes. Wearing safety glasses, safety shoes and a helmet is advisable and required by some local ordinances and insurance regulations.

## WHILE OPERATING

8. Do not run the engine in a confined area without adequate ventilation. Exhaust fumes are hazardous and could possibly be deadly.

9. This vehicle is designed to carry only You, the operator and one passenger in the seat provided by the manufacturer. NEVER carry passengers on the machine and keep everyone away from the areas of operation.

10. Make sure all hydraulic fittings are tight and all hydraulic hoses are in good condition before operating this unit.

11. Keep hands and feet out of hopper when unit is operating or engine is running on vehicle.

12. Operator and passenger should remain seated whenever the vehicle is in motion.

13. Using the machine demands attention. Failure to operate vehicle safely may result in an accident, tipover of vehicle and serious injury or death. Drive carefully. To prevent tipping or loss of control:

A. Use extreme caution, reduce speed and maintain a safe distance around sand traps, ditches, creeks, ramps, any unfamiliar areas or other hazards.

B. Watch for holes or other hidden hazards.

C. Use caution when operating vehicle on a steep slope. Normally travel straight up and down slopes. Reduce speed when making sharp turns or when turning on hillsides. Avoid turning on hillsides whenever possible.

D. Use extra caution when operating vehicle on wet surfaces, at higher speeds or with a full load. Stopping time will increase with a full load. Shift into a lower gear before starting up or down a hill

E. Avoid sudden stops and starts. Do not go from reverse to forward or forward to reverse without coming to a complete stop.

F. Do not attempt sharp turns or abrupt maneuvers or other unsafe driving actions that may cause a loss of vehicle control.

G. Before backing up, look to the rear and assure no one is behind. Back up slowly.

H. Watch out for traffic when near or crossing roads. Always yield the right of way to pedestrians and other vehicles. This vehicle is not designed for use on streets or highways. Always signal your turns or stop early enough so other persons know what you plan to do. Obey all traffic rules and regulations.

I. Always watch out for and avoid low over-hangs such as tree limbs, door jambs, over-head walkways, etc. Make sure there is enough room over head to easily clear the vehicle and your head.

J. If ever unsure about safe operation, STOP WORK and ask your supervisor.

14. When loading with sand, distribute load evenly. Operate vehicle with extra caution when the hopper is full of sand. Keep load balanced to prevent it from shifting.

# SAFETY INSTRUCTIONS

## MAINTENANCE

**15.** Before servicing or making adjustments to the topdresser, stop engine of Workman, set parking brake and remove key from engine to prevent accidental starting of the engine.

**16.** Perform only those maintenance instructions described in this manual. If major repairs are ever needed or assistance is desired, contact an Authorized TORO Distributor.

**17.** To reduce potential fire hazard, keep the engine free of excessive grease, grass, leaves and accumulations of dirt.

**18.** Be sure machine is in safe operating condition by keeping nuts, bolts and screws tight.

**19.** Make sure all hydraulic line connectors are tight, and all hydraulic hoses and lines are in good condition before applying pressure to the system.

**20.** Keep body and hands away from pin hole leaks in hydraulic lines that eject high pressure hydraulic fluid. Use cardboard or paper to find hydraulic leaks.

Hydraulic fluid escaping under pressure can penetrate skin and cause injury. Fluid accidentally injected into the skin must be surgically removed within a few hours by a doctor familiar with this form of injury or gangrene may result.

**21.** Before disconnecting or performing any work on the hydraulic system, all pressure in system must be relieved by stopping engine and placing the remote hydraulic valve in the float detent position.

**22.** If the engine must be running to perform a maintenance adjustment, keep hands, feet, clothing and other parts of the body away from the engine and other moving parts.

**23.** To ensure optimum performance and safety, always purchase genuine TORO replacement parts and accessories to keep the Toro all TORO. NEVER USE "WILL-FIT" REPLACEMENT PARTS AND ACCESSORIES MADE BY OTHER MANUFACTURERS. Look for the TORO logo to assure genuineness. Using unapproved replacement parts and accessories could void the warranty of The Toro Company.

# SAFETY AND INSTRUCTION DECALS

The following decals are installed on the machine. If any become damaged or illegible, replace it. The decal part number is listed below and in your parts catalog. Replacement can be ordered from your Authorized Toro Distributor.

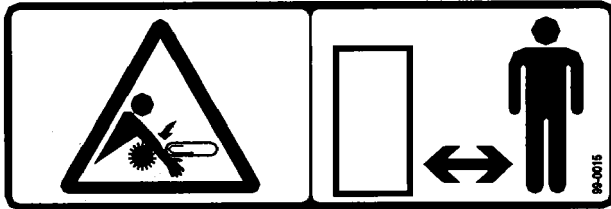

ON TOP AND REAR OF HOPPER  
BRUSH GUARD (2) & LEFT REAR  
CORNER OF FRAME MOTOR PLATE  
(Part No. 99-0015)

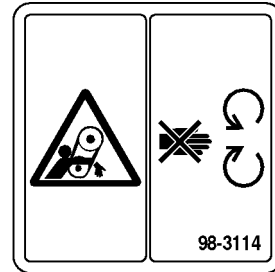

UNDER CHAIN GUARD ON MOTOR PLATE  
(Part No. 98-3114)

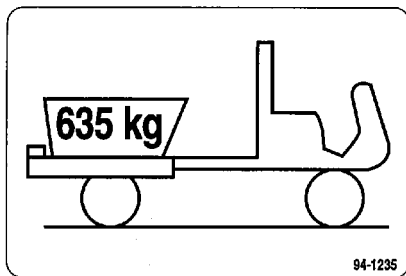

BOTH SIDES OF HOPPER (2)  
(Part No. 94-1235)

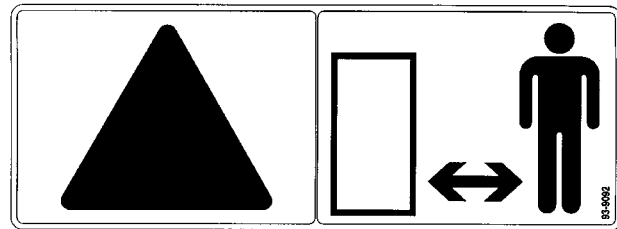

ON BOTH SIDES OF FRONT HOPPER FRAME (2)  
(Part No. 93-9092)



ON LIFT EYES (4)  
(Part No. 93-9084)

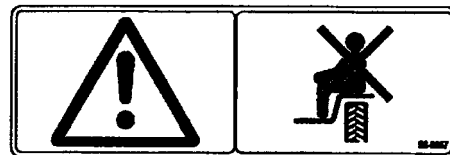

ON HOPPER BRUSH GUARD & LEFT REAR  
CORNER OF FRAME MOTOR PLATE  
(Part No. 93-9867)

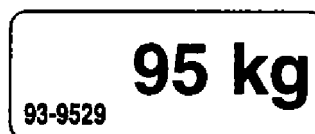

ON LIFT EYES (4)  
(Part No. 93-9529)

# SPECIFICATIONS

**Dimensions:**

Height: 49.5" (mounted on Workman)  
 Length: 54"  
 Width: 73"

**Hopper Dimensions:**

Height: 11.5"  
 Top Length: 33"  
 Width: 73"  
 Inside Clear Width: 69"

**Hopper Capacity:**

18 cubic feet

**Spreading Width:**

60"

**Top Dressing Speed:**

Variable to desired application rate.  
 2 to 7.7 mph (low range)

**Conveyor Belt:**

Continuous 60" wide traction grip PVC belt with heavy duty monofilament carcass.

**Metering Gate:**

Spring release flexible edge gate variable from closed to 3" opening for light to heavy applications.

**Drive:**

Hydraulic driven with Workman remote hydraulics.  
 Belt motor with chain reduction  
 Brush motor direct drive

**Shipping Weight:**

850 lbs.

**Dry Weight:**

808 lbs.

**Required Attachments:**

Remote Hydraulic Control Kit	Model No. 07415
Engine Cover Kit (Liquid Cooled Gas Workman)	Part No. 99-1214
Engine Cover Kit (Liquid Cooled Diesel Workman)	Part No. 92-5963
1/3 Area Cover	Part No. 93-9225
	or
1/3 Area Cover – CE	Part No. 93-9517
	or
1/3 Flat Bed	Model No. 07341

**Recommended Accessories:**

Tachometer Kit (Liquid Cooled Gas or Diesel Workman)	Part No. 87-9950
Tachometer Kit – CE (Liquid Cooled Gas or Diesel Workman)	Part No. 87-9970
Tachometer Kit (Air Cooled Gas Workman)	Part No. 87-9960
Hand Throttle Kit	Model No. 07416

**Optional Accessories:**

Lift Bracket Assembly	Part No. 92-4452
Jack Stands	Contact Distributor

**Specifications and design subject to change without notice.**

## LOOSE PARTS

**NOTE:** Use this chart as a checklist to assure all parts have been received. Without these parts, total set – up cannot be completed.

DESCRIPTION	QTY.	USE
Clevis Pin	2	Mount rear of topdresser to Workman
Lynch Pin	4	
Attachment Bracket	2	Mount front of topdresser to Workman
Capscrew – 1/2-13 x 1" lg.	4	
Flatwasher	8	
Locknut – 1/2-13	2	
Spacer Mount	2	Used when mounting front of topdresser to H.D. Hitch Frame
Cylinder Pin	2	Mount lift cylinder to topdresser
Capscrew 1/4-20 x 3/4" lg.	2	
Lock Nut 1/4-20	2	
Operator's Manual	2	Read Before Operating Machine
Parts Catalog	1	
Registration Card	1	Fill out and return to Toro
CE Certificate of Compliance	1	

# SET – UP INSTRUCTIONS

## REMOVE 2/3 OR FULL SIZE BED

(If so equipped)

**NOTE:** If the Workman is equipped with a H.D. Hitch Frame it does not have to be removed from the vehicle but the weight of the hitch frame must be subtracted from the payload capacity of the hopper. Refer to Operating Instructions, page 11.

1. With bed lowered, remove clevis pins and lynch pins securing each cylinder rod end to bed mounting plates (Fig. 1).

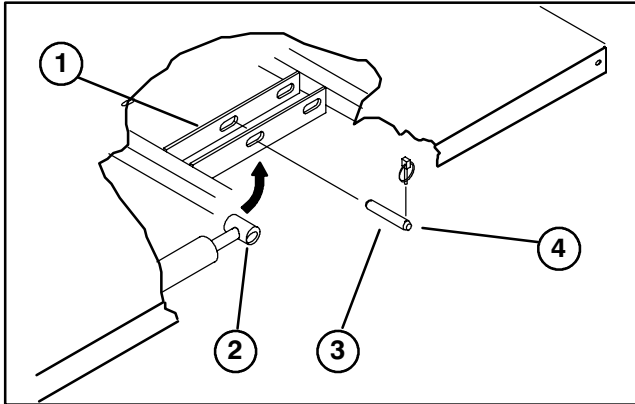

**Figure 1**

- |                       |               |
|-----------------------|---------------|
| 1. Bed mounting plate | 3. Clevis pin |
| 2. Cylinder rod end   | 4. Lynch pin  |

2. Remove clevis pin and (2) lynch pins securing each set of pivot plates to frame channels (Fig. 2).

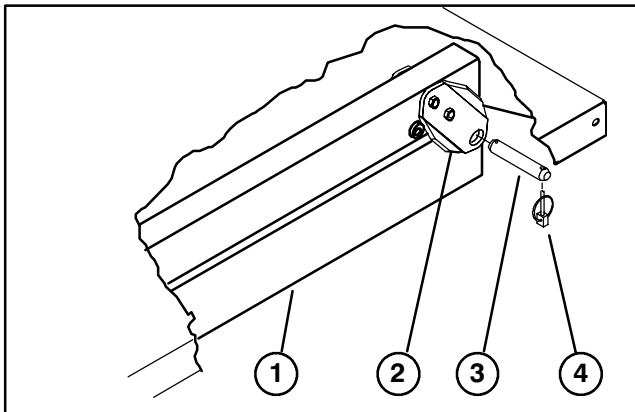

**Figure 2**

- |                          |               |
|--------------------------|---------------|
| 1. Vehicle frame channel | 3. Clevis pin |
| 2. Pivot plate           | 4. Lynch pin  |

3. Carefully remove bed from vehicle frame.

**CAUTION:** The full bed weighs approximately 210 pounds, so do not try to remove it by yourself. Get the help of two or three other people.

## MOUNT TOPDRESSER

**NOTE:** The Remote Hydraulic Control Kit (Model 07415) must be installed on the Workman before installation of the Topdresser 1800.

**NOTE:** A Engine Cover Kit, Part No. 99-1214 for Liquid Cooled Gas Workman or Part No. 92-5963 for Diesel Workman, must be installed on the Workman to prevent material overflowing directly onto the engine.

1. Remove (2) flange head capscrews and flange locknuts securing rear of each engine frame mounting bracket to each side of vehicle frame (Fig. 3).

**NOTE:** If the Workman is equipped with a H.D. Hitch Frame, the Attachment Mount Brackets (Steps 1 & 2) will already be mounted on Workman. Proceed to step 3.

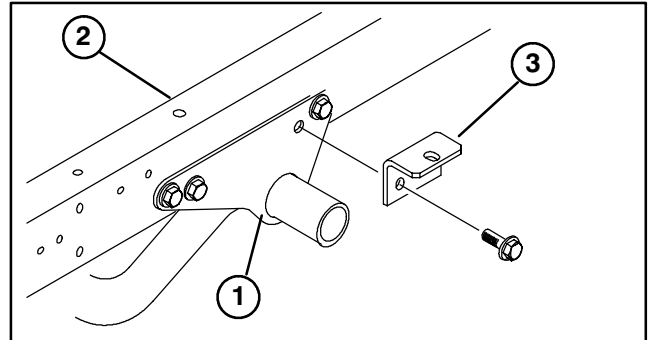

**Figure 3**

- |                                  |
|----------------------------------|
| 1. Engine frame mounting bracket |
| 2. Vehicle frame                 |
| 3. Attachment bracket            |

2. Loosely secure a attachment bracket to each engine frame mounting bracket and vehicle frame with (2) flange head capscrews and flange locknuts previously removed (Fig. 3).

**NOTE:** If the Workman is equipped with a H.D. Hitch Frame, install spacer mounts, steps 3 & 4, otherwise proceed to step 8.

3. Remove the capscrew, (2) flatwashers and locknut securing each attachment bracket to hitch frame tabs (Fig. 5).

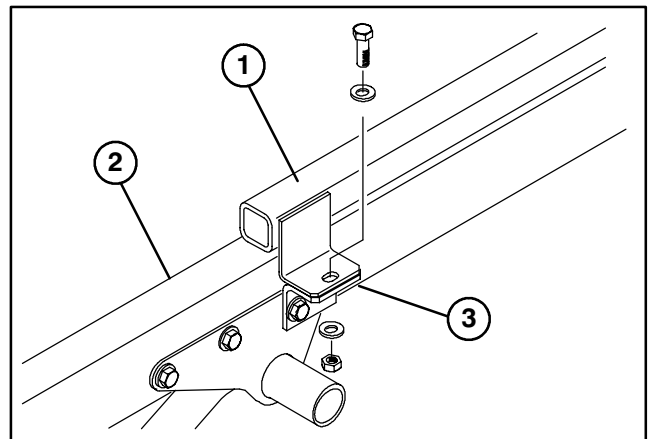
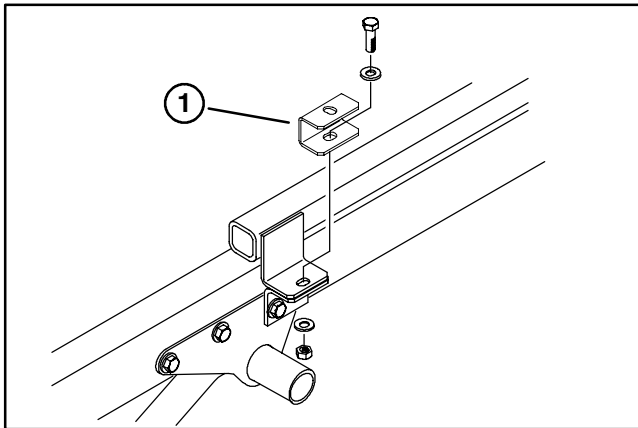

**Figure 4**

- |                       |
|-----------------------|
| 1. Hitch frame tab    |
| 2. Vehicle frame      |
| 3. Attachment bracket |

4. Secure a spacer mount to top of each hitch frame tab with the capscrew, (2) flatwashers and locknut previously removed (Fig. 5).

# SET-UP INSTRUCTIONS



**Figure 5**  
1. Spacer mount

5. Position Topdresser onto vehicle frame, aligning holes in rear mounting brackets with holes in each side of frame (Fig. 6).

**NOTE:** If using the optional Lift Assembly Kit (92-4452) to lift the topdresser, proceed as follows:

- A. Place the lift bracket on top of hopper.
- B. Attach the chains to lift eyes on each corner of hopper.



## WARNING

**WHILE USING THE OPTIONAL LIFT ASSEMBLY:**

**DO NOT position yourself under the topdresser while removing or installing.**

**DO NOT allow anyone else near the topdresser while removing or installing.**

**IMPORTANT:** When removing the topdresser, using the Lift Assembly, ALWAYS remove the mounting bolts and pins before lifting.

6. Secure each rear mounting bracket to vehicle frame with a clevis pin and (2) lynch pins (Fig. 6).

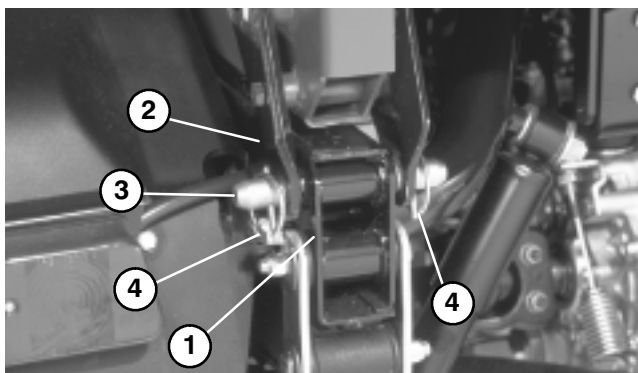

**Figure 6**

- 1. Vehicle frame channel
- 2. Mounting brackets
- 3. Clevis pin
- 4. Lynch pin

7. Loosely secure top of each attachment bracket (Fig. 7) or spacer mount (Fig. 8) to mounting tab on each side of topdresser with a 1/2-13 x 1" lg. capscrew, (2) flatwashers and locknuts. Tighten all fasteners.

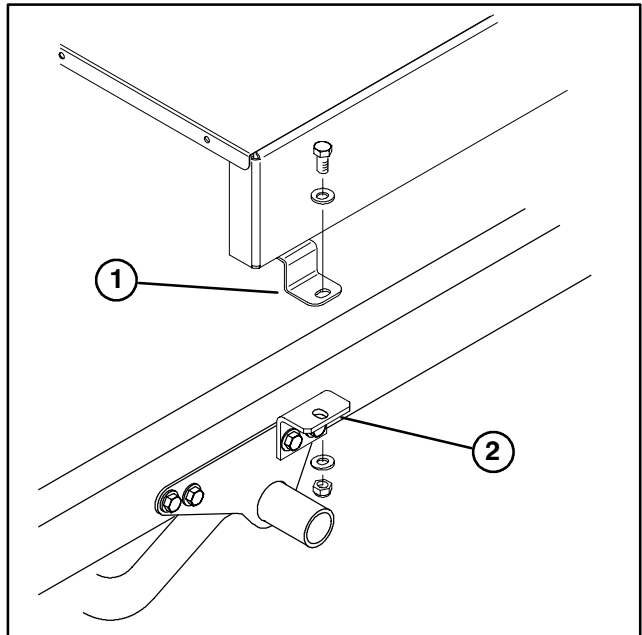

**Figure 7**

- 1. Topdresser mounting tab
- 2. Attachment bracket

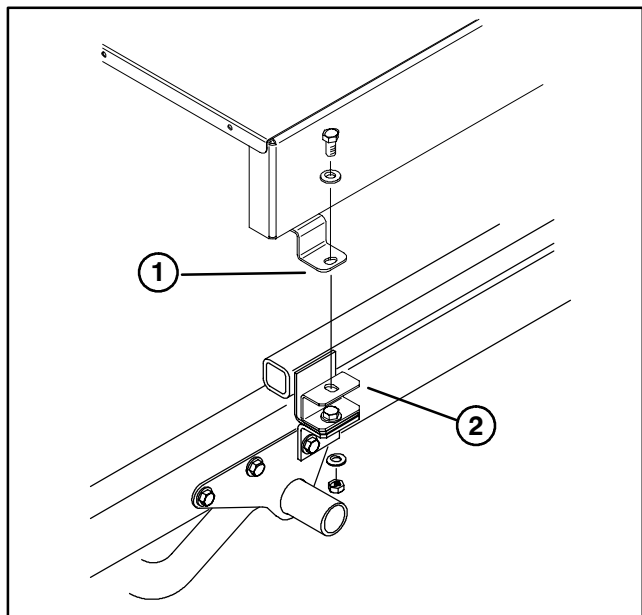

**Figure 8**

- 1. Topdresser mounting tab
- 2. Spacer mount

## CONNECT LIFT CYLINDERS

1. Secure each lift cylinder rod end to topdresser base with a cylinder pin.



# SET – UP INSTRUCTIONS

2. Secure each cylinder pin to topdresser base with a 1/4–20 x 3/4” lg. capscrew, flatwasher and nut (Fig. 9).

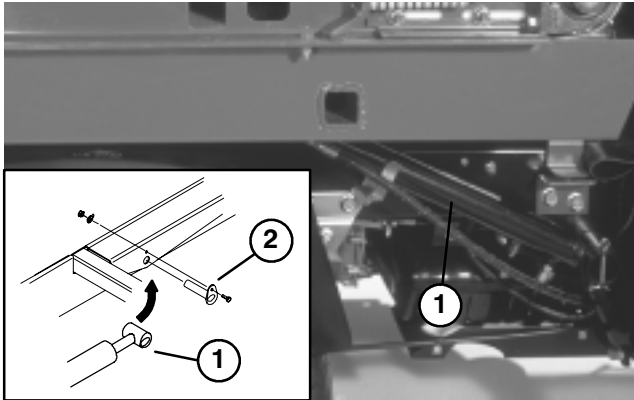

**Figure 9**

1. Cylinder rod
2. Cylinder pin

**IMPORTANT:** Always unlock the Dump Stop lever before attempting to attach the cylinder for tilting. Use the tilt of the cylinders only for service of the engine or hydraulics underneath.

**IMPORTANT: DO NOT** rely on the cylinders to hold up the topdresser. **ALWAYS** block the topdresser up before going underneath to perform any type of service.



## CAUTION

When tilting the hopper of the topdresser back to perform maintenance on the Workman.

**ALWAYS** remove the front mounting bolts first.

**ALWAYS** tilt the topdresser with an empty load

## SAFETY SUPPORT

ALWAYS use the safety supports supplied with the Workman to keep the cylinders in the extended position while performing maintenance.

1. Push safety support onto cylinder rod, making sure support end tabs rest on end of cylinder barrel and on cylinder rod end.
2. Always install or remove safety support from outside of topdresser.
3. Do not try to lower topdresser with safety support on cylinder.

## CONNECT HYDRAULIC COUPLERS

1. Place the Workman Remote Hydraulic Valve Handle of the in the float position.

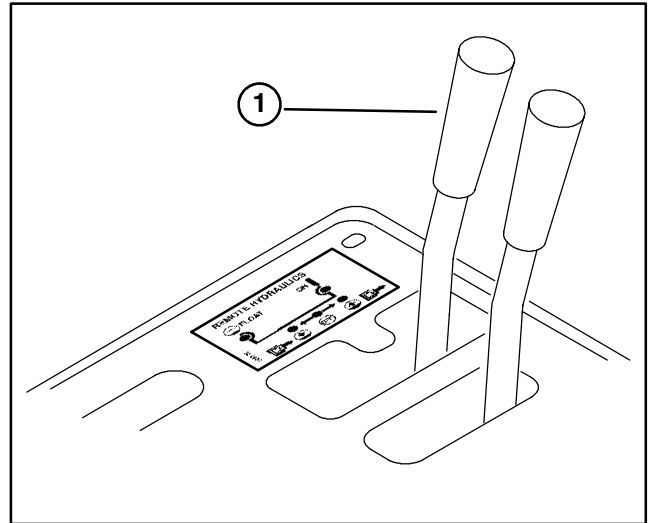

**Figure 10**

1. Hydraulic valve handle

2. Clean dirt from quick couplers (Fig. 11) before connecting. Dirty couplers can introduce contamination to the system. After cleaning, attach both quick couplers on the topdresser to the Workman. The hoses are marked “A” and “B”, match them to the quick couplers when installing. Assure both quick couplers are full engaged.

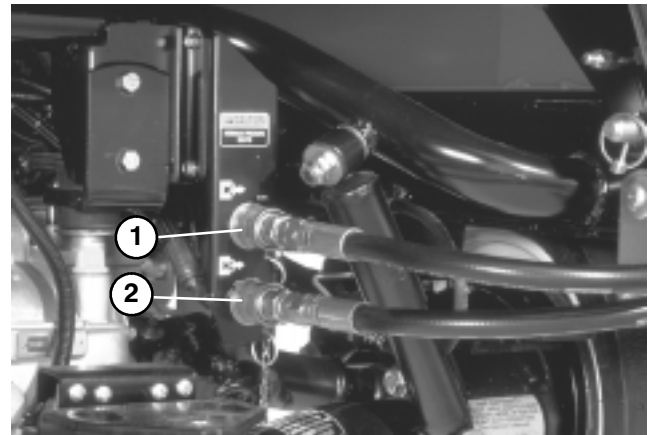

**Figure 11**

1. Coupler “A”
2. Coupler “B”

**IMPORTANT:** The Workman’s hydraulic system operates on Dexron II automatic transmission fluid. This fluid provides gear and bearing lubrication as well as fluid for operating the hydraulic system.

When the remote hydraulic system quick couplers are connected, hydraulic fluid flows from the topdresser to the vehicle. If the hydraulic fluid in the topdresser is not the same or equivalent to vehicle’s, component damage to transaxle or hydraulic system may result.

Fluid compatibility should be checked and appropriate action taken, if topdresser is subsequently used in conjunction with any other product using fluids other than Dexron II ATF.

# SET – UP INSTRUCTIONS



## CAUTION

Hydraulic fluid escaping under pressure can have sufficient force to penetrate skin and do serious damage. Care must be used when connecting or disconnecting hydraulic couplers. Stop engine, apply parking brake and place remote hydraulic valve in float detent position to relieve hydraulic pressure before connecting or disconnecting quick couplers.

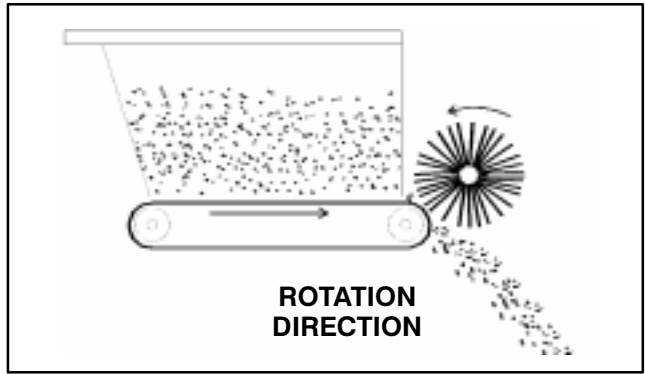

Figure 12

**IMPORTANT:** Check hydraulic oil level after installation of Topdresser 1800. Check operation of topdresser, then recheck hydraulic oil level. Operation of vehicle with low oil level can damage pump, remote hydraulics, power steering and vehicle transaxle. Use Dexron II automatic transmission fluid if needed.

3. Start vehicle engine and test rotation of the conveyor and brush. Place remote hydraulics lever of Workman in the “run” position. The rotation should be as shown in figure 12. If the rotation is backwards the quick couplers need to be reversed.

**IMPORTANT:** Make sure hoses are routed away from any moving, sharp or hot components.

4. Visually inspect the hydraulic system for leaks, loose fasteners, missing parts, improperly routed lines. Make all repairs before operating.

## CONTROLS

### GATE METERING CONTROL

The black knobs on the left rear side of the machine are used to adjust and lock the gate into the desired open height position.

1. Loosen the black knob enough to allow it to slide freely in the slot.
2. Set the gate into the desired position and tighten the black knob to lock into position.

### RATE SCALE

Use rate scale to determine desired flow rate. Refer to Sand Application Rate, page 11.

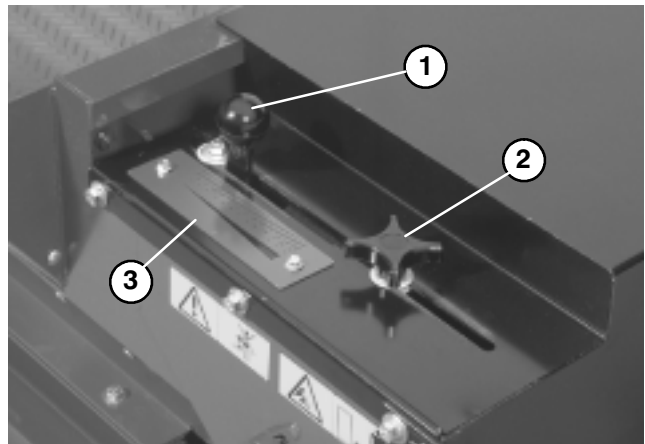

Figure 13

1. Gate adjusting knob
2. Adjustment locking knob
3. Rate scale

# OPERATING INSTRUCTIONS



## WARNING

Rotating parts can grab or pinch. Stay clear of brush and conveyor belt while unit is running.

Safe operation begins before taking the vehicle out for a day's work. Read and understand the operating instructions in the Toro Workman operator's manual before using the topdresser.



## CAUTION

The interlock switches are for the operator's protection, so do not bypass them. Check operation of the switches daily to assure interlock system is operating on the Workman. If a switch is malfunctioning replace it before operating. Regardless whether switches are operating properly or not, replace them every two years to assure maximum safety. Do not rely entirely on safety switches – use common sense!

1. Sit on operator's seat and engage parking brake.
2. Disengage PTO (if so equipped) and return hand throttle lever to OFF position (if so equipped).
3. Place the Workman Remote Hydraulic Valve Handle in the OFF position.
4. Move shift lever to NEUTRAL position and depress clutch lever.
5. Insert key into ignition switch and rotate it clockwise to start the engine. Release key when engine starts.
6. Practice starting, driving and stopping the Workman. Always read and understand the operator's manual for the Workman before using this unit.
7. Check for smooth operation of belt before adding material in hopper.
8. Place sand or other topdressing material in the hopper. The maximum volume of material that can be put into the hopper is 18 cubic feet. Generally, sand weighs 100 pounds per cubic foot and could overload the Workman if more than 1400–1500 pounds are loaded into the hopper.

**IMPORTANT:** When any other attachments, such as the H.D. Hitch frame, are installed on the Workman while using the Topdresser, the weight of those

attachments must be subtracted from the payload capacity of the hopper.

A method for determining the total weight of your attachments would be to place the rear tires on a scale. **The maximum weight capacity of the rear axle of the Workman is 2600 pounds.**



## DANGER

As a general rule, position the weight of the load evenly from front to rear and evenly from side to side.

Transporting or topdressing with a full load can cause shifting of the sand. This shifting happens most often while turning, going up or down hills, suddenly changing speeds or while driving over rough surfaces. Shifting loads can lead to tipovers. Use caution when transporting or topdressing with a full load.

Heavy loads increase stopping distance and reduce your ability to turn quickly without tipping over.

**NEVER tilt the Topdresser Bed for maintenance with any material in the hopper. Always tilt the topdresser bed with a empty hopper.**

9. Transport to the area to be topdressed.
10. Adjust the metering gate to the desired rate. Lock into position with the black knob.
11. Move the shift lever into "LO" range position. Select the desired forward speed and begin moving. Refer to the following section, Sand Application Rate.
12. Pull the Remote Hydraulic Lever back to the "RUN" position. The unit is now topdressing.

## SAND APPLICATION RATE

The rate of sand applied depends on the gate setting and the gear/range setting. Sand varies in moisture and coarseness (size of grain) which effects the rate. These factors must be taken into consideration when deciding the amount of sand required for the application. Test a small area to decide the correct amount. To increase application rate, either open gate to a higher scale mark or shift Workman to a lower gear.

To assure consistent application, from green to green, it is highly recommended to use a tachometer and/or hand throttle to maintain constant engine speed while topdressing.

# OPERATING INSTRUCTIONS



## WARNING

Tipping or rolling the vehicle on a hill will cause serious injury.

If engine stalls or you lose headway on a hill, never attempt to turn vehicle around.

Always back straight down a hill in reverse gear.

NEVER back down in neutral or with the clutch depressed, using only the brakes.

NEVER add sideboards or panels to the top of the hopper to increase the load capacity. The additional weight will cause tipping or rolling of the vehicle and lead to serious injury.

NEVER drive across a steep hill, always drive straight up or down. Avoid turning on a hill. Don't "drop the clutch" or slam on the brakes. Sudden speed change can initiate tipover.

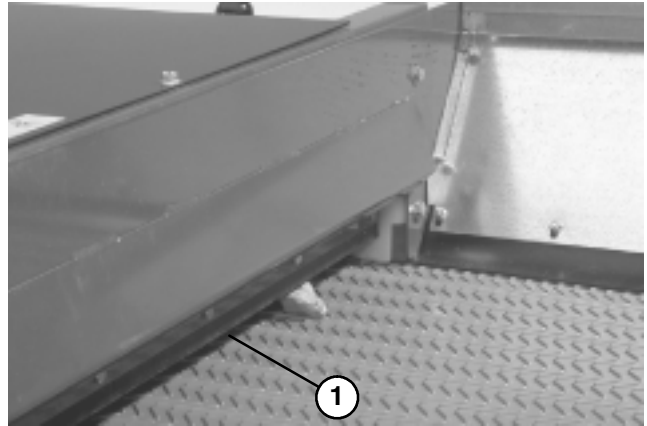

Figure 14

1. Gate edge

## COLD WEATHER OPERATION

The Topdresser 1800 may be used in cold weather, with certain limitations, to apply a salt/sand mixture on pavement for ice control. The PVC conveyor belt material becomes very stiff in cold weather and requires more power to operate belt. The life of the belt is reduced by approximately 50% when operated below temperatures of 40° F (5° C). **Under no conditions should the topdresser be operated below temperatures of 20° F (-7° C).**

1. Increase belt tension by adjusting spring compression to 4 inches (101 mm). Refer to Adjusting Conveyor Belt, page 14.

2. Always run belt, before adding material, to assure moisture has not frozen belt system. Damage to belt or roller may occur if belt/drive roller slip.

**IMPORTANT: Always re-set belt tension to normal 4-7/16" (112 mm) spring compression adjustment before operating topdresser under normal temperature conditions.**

## SAND PRECAUTIONS

The Topdresser 1800 is equipped with a flexible gate edge (Fig. 14) and spring release mechanism to reduce the chance of sand chunks or rocks getting lodged during operation. To insure long belt life, sift or check sand for rocks with sharp edges that may damage conveyor belt.

## LUBRICATION

### GREASING BEARINGS

The Topdresser 1800 has 5 grease fittings that must be lubricated with a No. 2 Lithium based grease. Lubricate after every 25 hours of operation.

The grease fitting locations (Fig. 15) and quantities are: Roller shaft bearings (4) and Brush shaft bearing (1).

**IMPORTANT: Lubricate the bearings to maintain a slight leakage between bearings and housings. Too much grease can cause overheating.**

**NOTE:** We do not recommend lubricating the drive chain unless it becomes stiff because of rust. If the chain rusts, it may be lubricated lightly with a DRY-TYPE LUBRICANT.



Figure 15

# MAINTENANCE



## WARNING

Before servicing or making adjustments to the machine, stop engine, set parking brake and remove key from ignition switch. Any load material must be removed from hopper before working under raised topdresser. Always install safety supports on cylinders before working under raised topdresser.

## BRUSH ADJUSTMENT

Brush must make enough contact with conveyor belt to disperse topdressing material but not restrict the rotation of the brush. A piece of stiff paper can be inserted between the conveyor belt and the brush to check the adjustment. The brush must be the same height from side to side. The brush adjustment should be checked weekly for wear. The bristles of the brush will wear under normal conditions and the distance from the brush to conveyor belt should be maintained to prevent uneven wear of the brush.

**NOTE:** If using moist top dressing materials, brush may have to be adjusted so bristles will whisk material from between conveyor belt lugs without severely contacting smooth portion of belt.

1. Loosen nuts securing bearing housing (Fig. 16) to right side of machine.

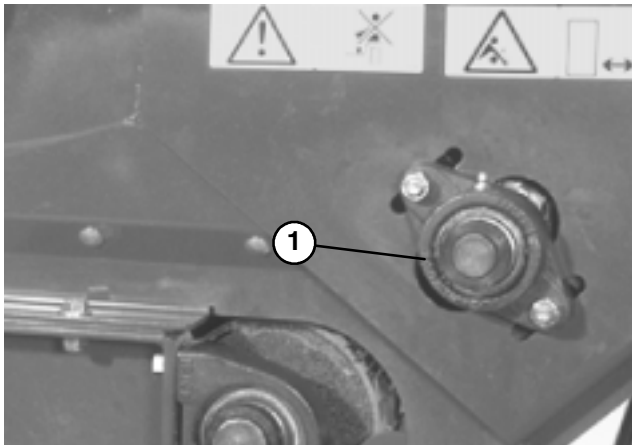

**Figure 16**

1. Bearing housing

2. Loosen nuts securing brush motor (Fig. 17) to left side of machine.

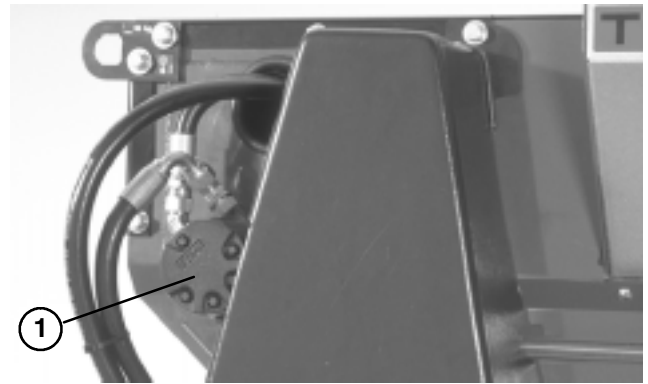

**Figure 17**

1. Brush motor

3. Slide brush into position on right side. Finger tighten nuts.
4. Slide brush into position on left side. Finger tighten nuts.
5. Insert a piece of stiff paper between the brush and the conveyor belt. The brush must be the same height from side to side.
6. If the adjustment is correct, tighten nuts. If not, repeat procedure.

## DRIVE CHAIN TENSION

The chain should be tensioned so it deflects 1/8". Do not over tighten, this will cause chain wear. Do not operate with a loose chain, this will cause sprocket wear.

1. Remove chain cover, spacer and finger guard (Fig. 18).

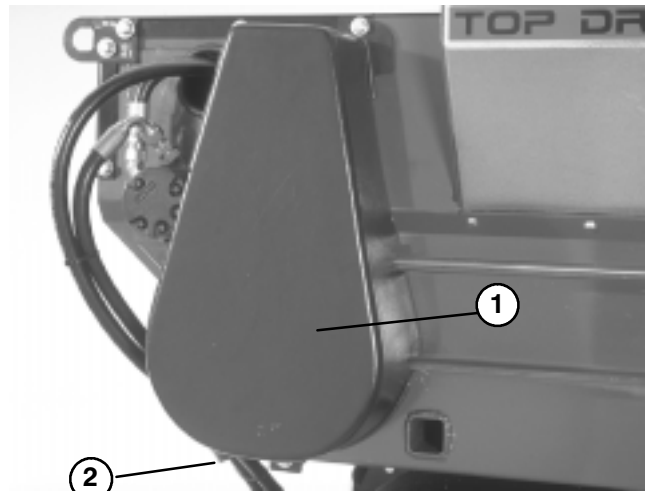
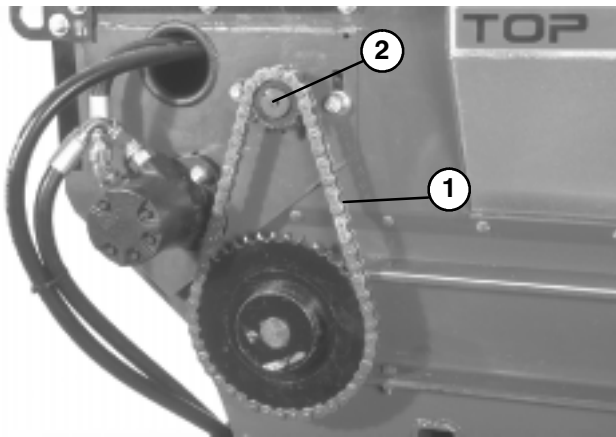

**Figure 18**

1. Chain cover
2. Finger guard & spacer

2. Loosen bolts and nuts securing motor and sprocket assembly to the main frame (Fig. 19).
3. Rotate motor and sprocket assembly, in mounting slots, until proper tension is achieved.

# MAINTENANCE



**Figure 19**  
 1. Drive chain  
 2. Motor & sprocket assembly

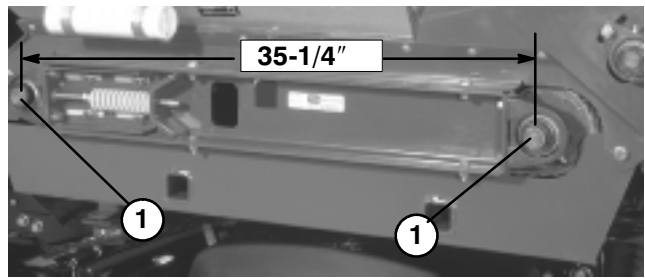

**Figure 21**  
 1. Conveyor belt roller shafts

## REPLACING CONVEYOR BELT

When replacing a damaged or worn conveyor belt, always inspect hopper seals (Fig. 22) and gate edge (Fig. 22) for wear or torn edges. Replace worn or torn components to insure proper operation of new conveyor belt.

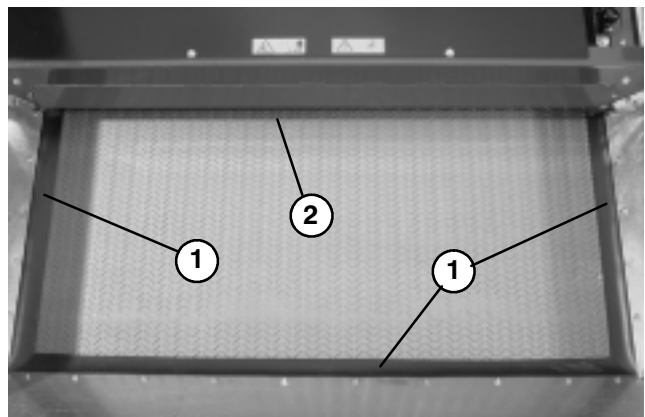

**Figure 22**  
 1. Hopper seal  
 2. Gate edge

4. Tighten mounting bolts.
5. Install cover, spacer and finger guard.

## ADJUSTING CONVEYOR BELT

When conveyor belt is adjusted properly, the compressed length of each compression spring should be 4-7/16" (112 mm). Adjust conveyor belt as follows:

1. Loosen jam nuts and adjust tension rod nuts to attain desired tension.

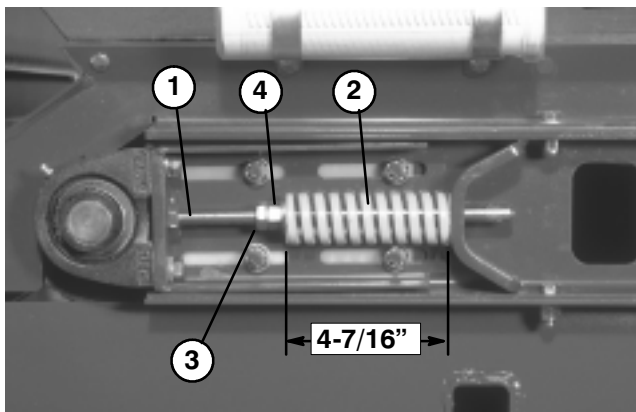

**Figure 20**  
 1. Tension rod  
 2. Compression spring  
 3. Jam nut  
 4. Nut

2. Tighten jam nuts to lock adjustment.
3. Check to insure that the center distance between conveyor belt roller shafts (Fig. 21), on each side of machine, are equal distance (approximately 35-1/4").

1. Remove chain cover, spacer and finger guard (Fig. 23).

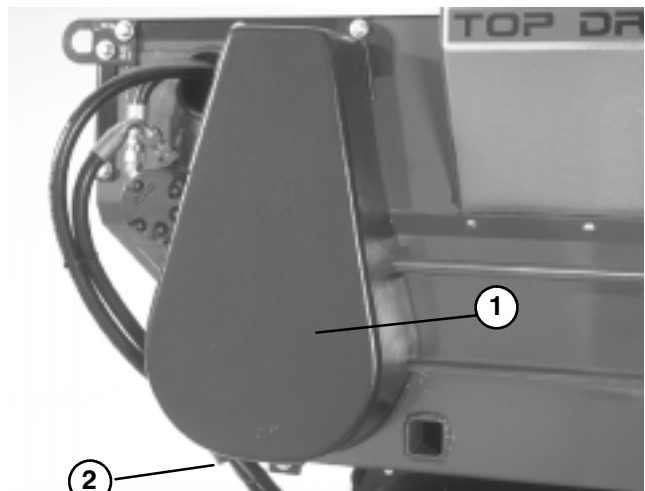

**Figure 23**  
 1. Chain cover  
 2. Finger guard & spacer

2. Remove master link from chain and remove chain from small sprocket (Fig. 24).

# MAINTENANCE

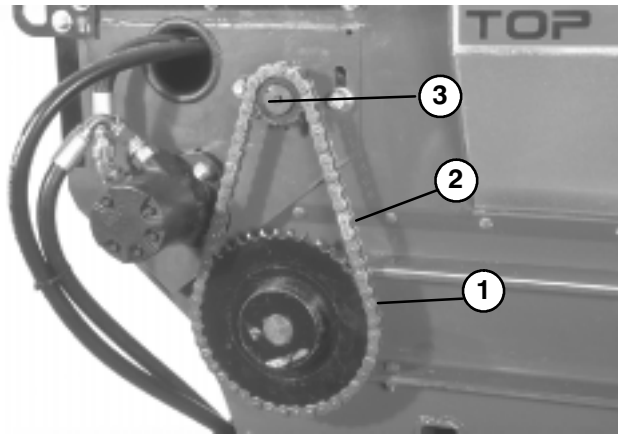
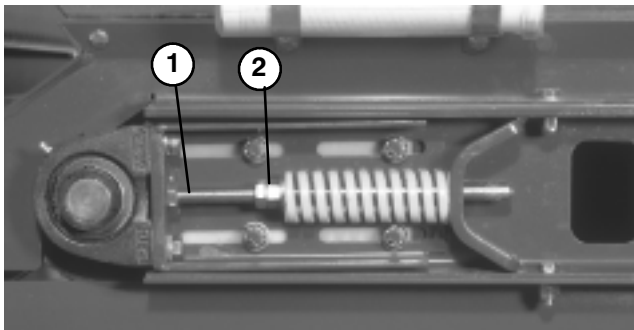

**Figure 24**

1. Drive chain
2. Master link
3. Motor

**Note:** Motor mounting bolts may have to be loosened to disassemble chain link.

3. Loosen jam nuts and nuts on tension rod to release spring tension (Fig. 25).



**Figure 25**

1. Tension rod
2. Nuts

4. Remove (2) cap screws, washers and nut, on each side of machine, securing hopper to slider bed (Fig. 26).

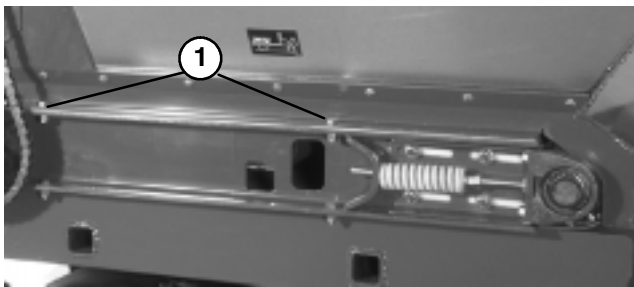
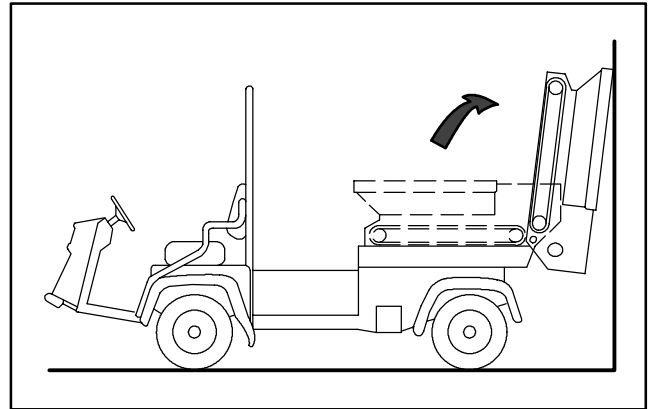

**Figure 26**

1. Hopper mounting cap screws  
(Right side shown)

5. Pivot hopper rearward and lean against wall, ladder, etc. Do not allow hopper to rest against rear of machine as damage may result to brush or hydraulic couplers (Fig. 27).

**IMPORTANT:** Make sure hopper is pivoted beyond center and/or secured to wall or post to prevent it from accidentally falling on work area (Fig. 27).



**Figure 27**

6. Loosen (2) cap screws, washers and nut, on right side of machine, securing slider bed to frame (Fig. 28). Make sure fasteners are loose enough to allow slider bed to be tipped.

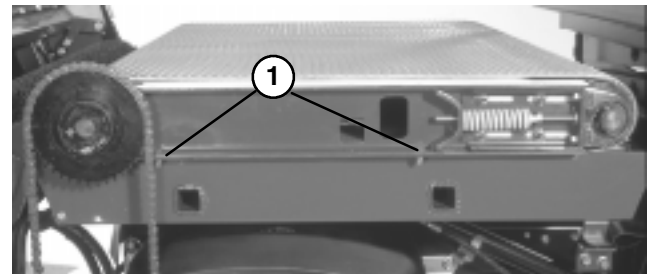

**Figure 28**

1. Slider bed mounting cap screws

7. Remove (2) cap screws, washers and nut, on left side of machine, securing slider bed to frame (Fig. 29).

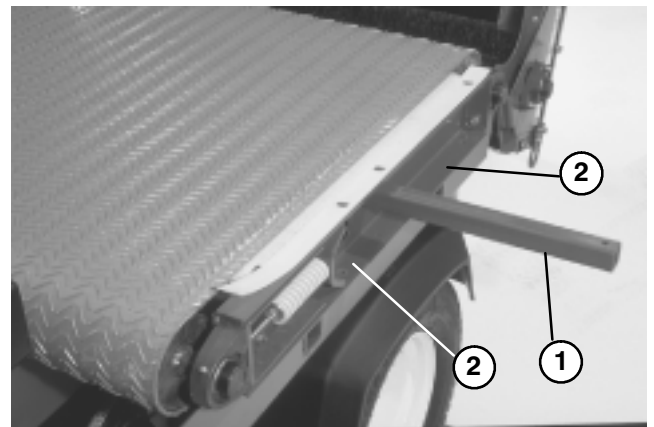

**Figure 29**

1. Lifting rod
2. Slider bed mounting cap screws

# MAINTENANCE

8. To remove belt:
  - A. Cut belt and remove from rollers  
or
  - B. Insert a plastic belt tool between each roller and belt. Rotate rollers until each tool is positioned to the outside of each roller. Tool must be inserted past rib in center of belt.
  - C. Insert a lift bar into hole on left side of machine.
  - D. Raise lift bar to tip slider bed.
  - E. Slide belt and belt tools off the rollers at the same time.
9. To install belt:
  - A. Insert a lift bar into hole on left side of machine and raise lift bar to tip slider bed (Fig. 29).
    - B. Insert belt onto rollers as far as possible.
    - C. Insert a plastic belt tool between each roller and belt. Rotate rollers until each tool is positioned to the outside of each roller. Tool must be inserted past rib in center of belt.
    - D. Slide belt and belt tools onto rollers until belt is approximately centered on rollers.
    - E. Remove belt tools from between belt and rollers.
    - F. Position belt so rib fits into alignment grooves in each roller.
    - G. Reverse procedure to re-assemble hopper and chain components.
    - H. Adjust belt. Refer to Adjusting Conveyor Belt, page 14.



# MAINTENANCE

## TROUBLE SHOOTING

### A. Difficulty in connecting or disconnecting quick couplers:

- Pressure not relieved (Quick coupler under pressure).
- Engine running.
- Remote hydraulic valve not placed in float.

### B. Power Steering Hard:

- Remote hydraulic valve linkage out of adjustment.
- Hydraulic oil level low.
- Hydraulic oil hot.

### C. Hydraulic leaks:

- Fittings loose.
- Fitting missing o-ring.

### D. Attachment does not function:

- Quick couplers not fully engaged.
- Quick couplers are interchanged.
- Belt Slipping – Check tension.

# HYDRAULIC SCHEMATIC

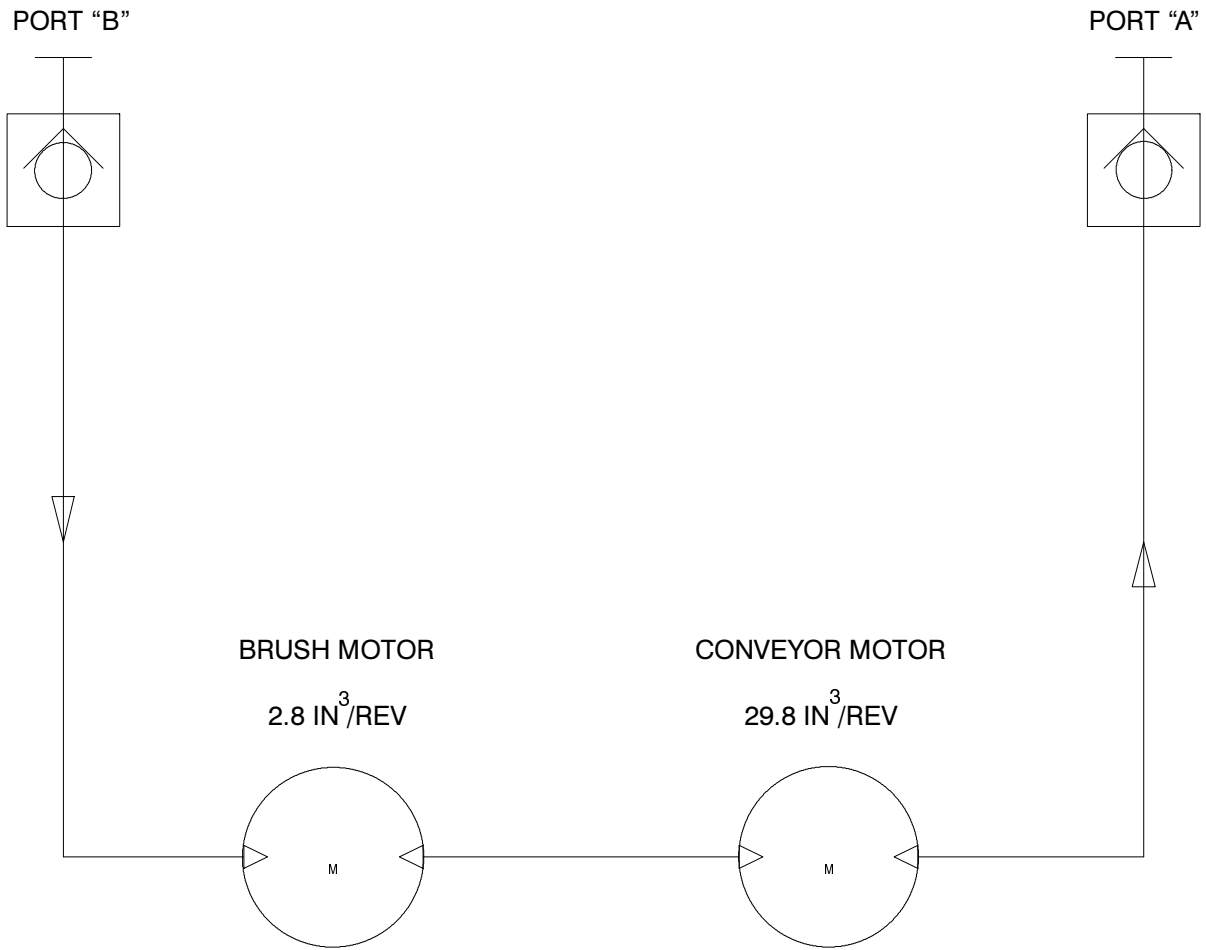

# SEASONAL STORAGE

Thoroughly clean the topdresser, especially inside the hopper. The hopper and conveyor belt area should be free of any remaining sand particles.

1. Tighten all fasteners.
2. Lubricate all grease fittings and bearings. Wipe off excess lubricant.
3. The unit should be stored out of the sun to prolong the life of the conveyor belt. When stored outside it is recommended to cover the hopper with a tarp.
4. Check the tension of the drive chain. Adjust the tension, if necessary.
5. Check the tension of the conveyor belt. Adjust the tension, if necessary.
6. When bringing topdresser out of storage, check for smooth operation of belt before adding material in hopper.

## IDENTIFICATION AND ORDERING

### MODEL AND SERIAL NUMBERS

The Topdresser 1800 has two identification numbers: a model number and a serial number. These numbers are stamped into a plate located on left side of slider frame (Fig. 30).

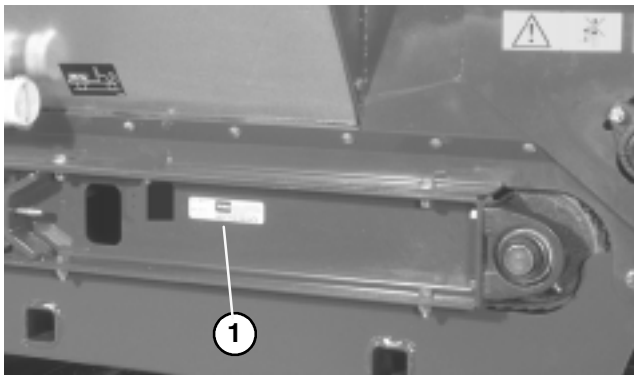

**Figure 30**

1. Model and serial number

To order replacement parts from an authorized TORO Distributor, supply the following information:

1. Model and serial numbers of the machine.
2. Part number, description and quantity of parts desired.

**Note:** Do not order by reference number if a parts catalog is being used; use the part number.

# The Toro Commercial Products Two Year Limited Warranty

The Toro Company warrants your 1996 or newer Toro Commercial Product ("Product") purchased after January 1, 1997, to be free from defects in materials or workmanship for the period of time listed below. Where a warrantable condition exists, Toro will repair the Product at no cost to you including diagnosis, labor, parts, and transportation. This warranty begins on the date the Product is delivered to the original retail purchaser.

**Warranty Duration: Two years or 1500 operational hours\*, whichever occurs first.**

**\*Product equipped with hour meter**

## Owner Responsibilities:

As the Product owner, you are responsible for required maintenance and adjustments stated in your Owner's Manual. Failure to perform required maintenance and adjustments can be grounds for disallowing a warranty claim.

## Instructions for Obtaining Warranty Service:

You are responsible for notifying the Commercial Products Distributor or Authorized Commercial Products Dealer from whom you purchased the Product as soon as you believe a warrantable condition exists.

If you need help locating a Commercial Products Distributor or Authorized Dealer, or if you have questions regarding your warranty rights or responsibilities, you may contact us at:

Toro Commercial Products Service Department  
8111 Lyndale Avenue South  
Minneapolis, MN, 55420-1196  
Telephone: (612) 888-8801  
Facsimile: (612) 887-8258  
E-Mail: Commercial.Service@Toro.Com

## Maintenance Parts:

Parts scheduled for replacement as required maintenance ("Maintenance Parts"), are warranted for the period of time up to the scheduled replacement time for that part.

## Items/Conditions Not Covered:

Not all product failures or malfunctions that occur during the warranty period are defects in materials or workmanship. The items / conditions listed below are not covered by this warranty:

- Product failures which result from the use of non-Toro replacement parts, or from installation and use of add-on, modified, or unapproved accessories are not covered.
- Product failures which result from failure to perform required maintenance and/or adjustments are not covered.
- Product failures which result from operating the Product in an abusive, negligent or reckless manner are not covered.

- This warranty does not apply to parts subject to consumption through use unless found to be defective. Examples of parts which are consumed, or used up, during normal Product operation include, but are not limited to, blades, reels, bedknives, tines, spark plugs, castor wheels, tires, filters, belts, etc.
- This warranty does not apply to failures caused by outside influence. Items considered to be outside influence include, but are not limited to, weather, storage practices, contamination, use of unapproved coolants, lubricants, additives, or chemicals, etc.
- This warranty does not apply to normal "wear and tear" items. Normal "Wear and Tear" includes, but is not limited to, damage to seats due to wear or abrasion, worn painted surfaces, scratched decals or windows, etc.

## Other Legal Disclaimers:

The above remedy of product defects through repair by an authorized distributor or dealer is the purchaser's sole remedy for any defect. This warranty gives you specific legal rights, and you may also have other rights which vary from state to state.

**Except for the Emissions warranty referenced below, if applicable, there is no other express warranty. All implied warranties of merchantability and fitness for use are limited to the duration of the express warranty.**

Some states do not allow limitations on how long an implied warranty lasts, so the above limitation may not apply to you.

**The Toro Company is not liable for indirect, incidental or consequential damages in connection with the use of the Product, including any cost or expense of providing substitute Product or service during periods of malfunction or non-use.**

Some states do not allow the exclusion of incidental or consequential damages, so the above exclusion may not apply to you.

**Note to California residents:** The Emissions Control System on your Product may be covered by a separate warranty meeting requirements established by the U.S. Environmental Protection Agency (EPA), or the California Air Resources Board (CARB). The hour limitations set forth above do not apply to the Emissions Control System Warranty. Refer to the California Emission Control Warranty Statement printed in your Owner's Manual or contained in the engine manufacturer's documentation for details.