



Topdresser 1800
for Workman[®] 3000/4000 Series
Model No. 44225—90001 and Up

Parts Catalog

Ordering Replacement Parts

To order replacement parts, please supply: the part number, the quantity, and the description of each part desired.

Understanding Reference Numbers

Each identified part in an illustration has a reference number. The reference number for a part also appears in the parts list, along with other information about the part.

This catalog uses two special reference number formats, one to indicate parts in a service assembly and another to indicate the quantity of a given part in an illustration.

Service Assembly Reference Numbers

Parts in service assemblies have reference numbers in the form **a:b**. The **a** represents the reference number of the entire service assembly and the **b** represents a sequential number unique to each part within the service assembly.

For example, a wheel assembly might be identified by reference number **6**, the tire by **6:1**, the valve by **6:2**, and the wheel by **6:3**. When you order the assembly identified by reference number **6**, you receive all parts identified by reference numbers **6:1**, **6:2**, and **6:3**. However, you may also order any part individually.

Reference numbers of this type appear in illustrations and in part lists.

Reference Numbers Indicating Quantity

In an illustration, if a reference number indicates more than one part, the reference number has the form **nX y**. The **n** represents the quantity of the part, the **X** is the multiplication symbol, and the **y** represents the reference number.

For example, in an illustration, the reference number **2X 37** means that two of the parts identified by reference number **37** are indicated.

Contents

Description	Page	Description	Page
Frame Assembly	3	Hopper Assembly	7
Slider Bed and Roller Assembly	4	Gate Slide and Brush Guard Assembly	8
Gate Assembly	5	Chain, Sprocket, and Guard Assembly	9
Brush and Motor Assembly and Hydraulic Schematic	6		

Accessories

Description	Model / Parts No.	Description	Model / Parts No.
Lift Bracket Assembly	92-4452		

Part Description Abbreviations

Part descriptions in this catalog may include the following abbreviations.

Abbreviation	Meaning	Abbreviation	Meaning
AR	as required	INC	incorporated
ASM	assembly	LH	left hand
CARR	carriage	NI	nylon insert
DEG	degrees	PPH	Phillips pan head
FH	flat head	PTH	Phillips truss head
GA	gauge	PTO	power take off
HF	hex flange	RH	right hand
HH	hex head	SFH	slotted fillister head
HHF	hex head flange	SHH	slotted hex head
HLH	hex lag head	SQH	square head
HJ	hex jam	SHWH	slotted hex washer head
HOC	height-of-cut	SPH	slotted pan head
HS	hex socket	SRH	slotted round head
HSBH	hex socket button head	STD	standard
HSFH	hex socket flat head	TAP	self tapping
HSH	hex socket head	TTH	Torx truss head
HWH	hex washer head	WH	wing head
HWHTF	hex washer head thread forming		

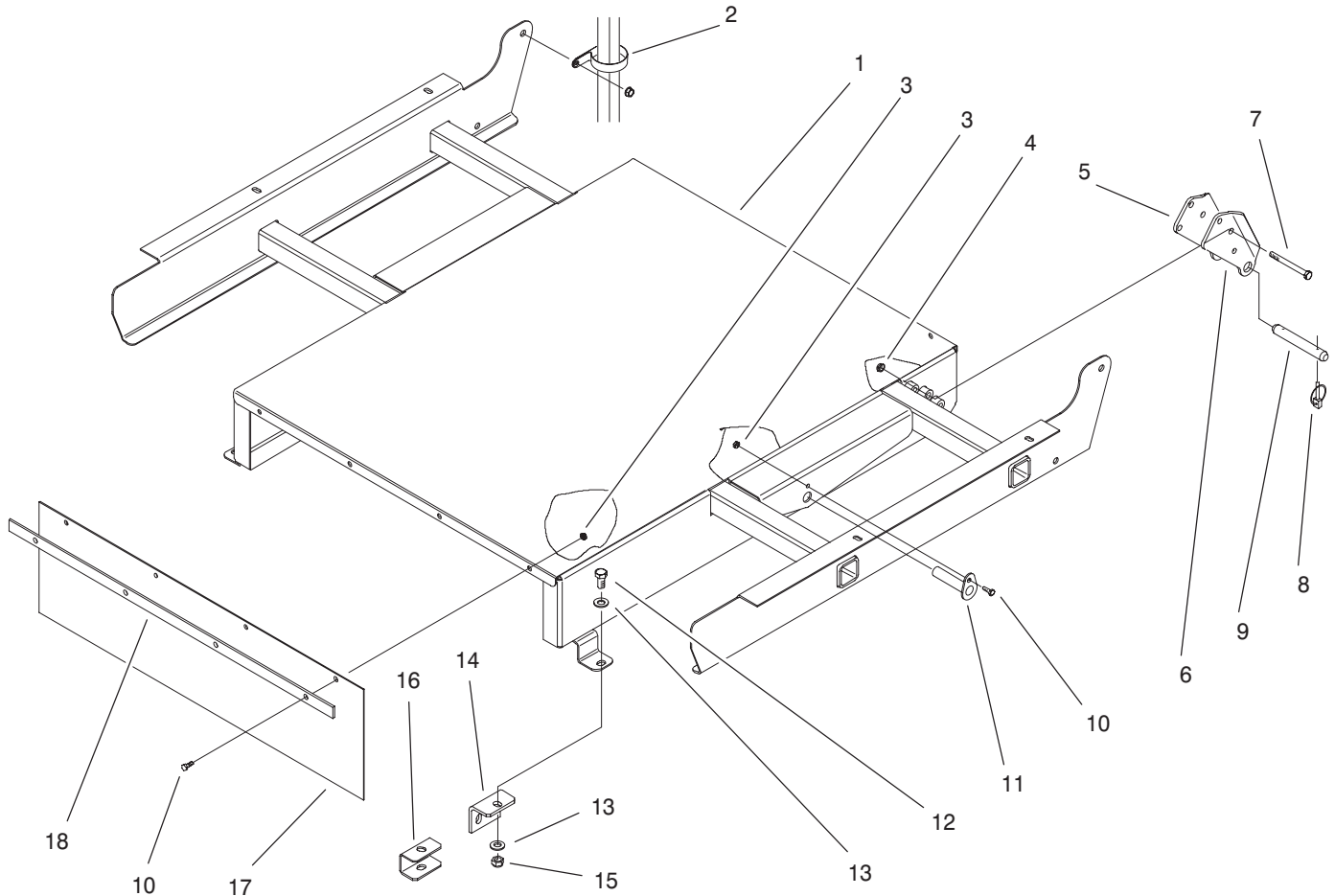

Sheet No.: 2

Frame Assembly

Ref. No.	Part No.	Qty.	Description
1	99-0030-01	1	Base ASM
2	100-1424	1	Clamp-R
3	3296-42	10	Nut-Lock
4	3296-44	8	Nut-Lock NI
5	93-9721	2	Bracket-Pivot, Long RH
6	93-9720	2	Bracket-Pivot, Long LH
7	323-42	8	Screw-HH
8	92-1298	4	Pin - Lynch
9	92-1233	2	Pin-Clevis
10	321-4	10	Screw-HH
11	92-4459	2	Pin-Cylinder
12	325-4	4	Screw-HH
13	3256-26	8	Washer-Flat
14	92-2667	2	Bracket - Att. Mount
15	3296-25	4	Nut-Lock NI
16	92-4576	2	Spacer-Mount
17	100-1423	2	Cover-Rubber
18	100-1422	2	Clamp-Rubber

Ref. No.	Part No.	Qty.	Description

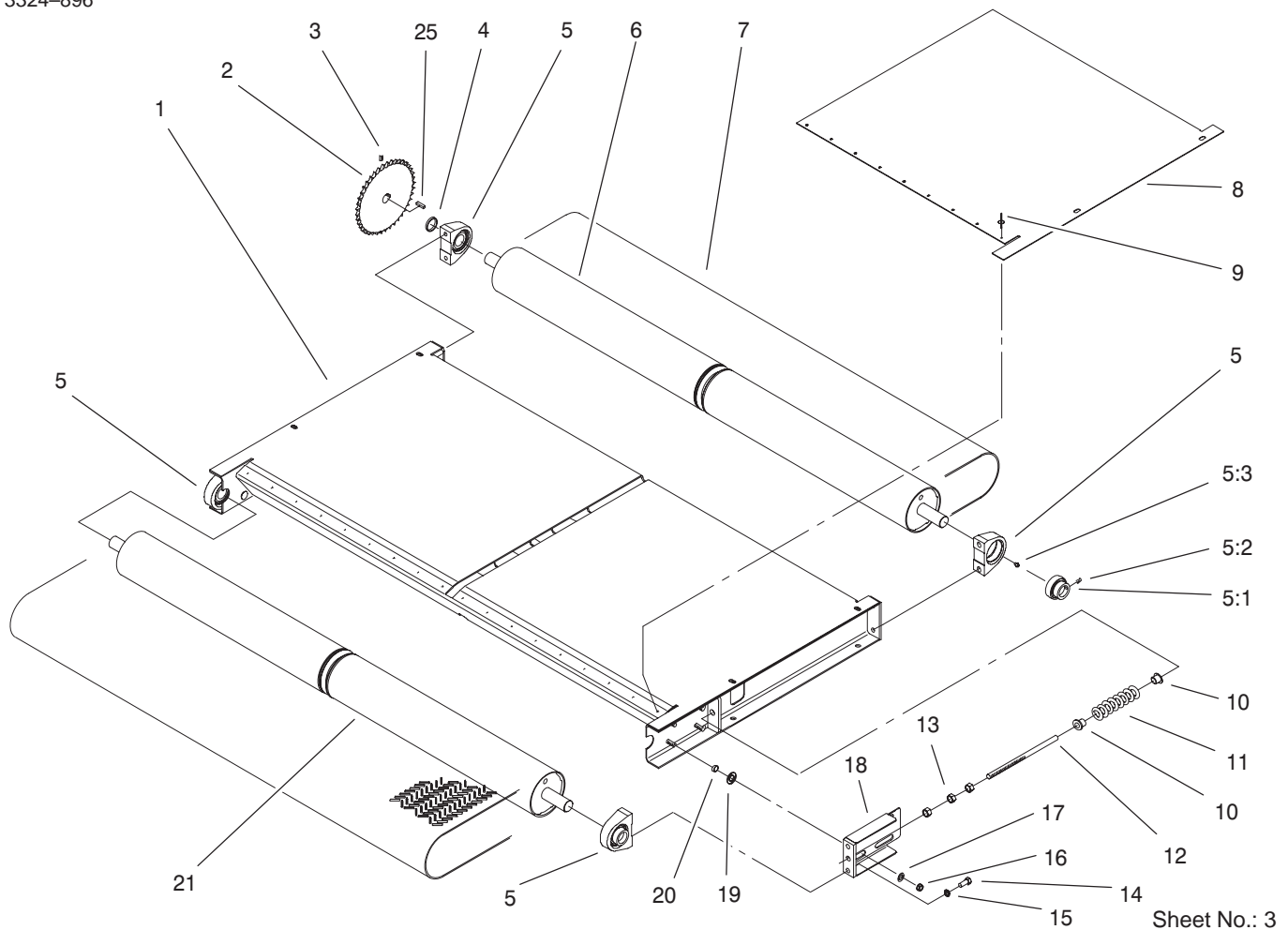

Slider Bed and Roller Assembly

Ref. No.	Part No.	Qty.	Description
1	99-0038-01	1	Frame-Bed, Slider
2	99-0166-03	1	Sprocket-Driven
3	3246-3	2	Screw-HS
4	99-0017-01	1	Spacer-Sprocket
5	99-0158	4	Bearing-Base, Tapped
5:1	251-246	1	Collar w/Set Screws
5:2	3245-35	1	Screw-HS
5:3	302-2	1	Fitting-Grease
6	99-0046	1	Roller-Rear
7	100-1425	1	Kit-Belt
8	99-0047	2	Plate-Wear
9	3269-28	18	Rivet-Pop
10	100-1414	4	Holder-Spring
11	99-0163	2	Spring-Compression
12	99-0118	2	Pin-Spring
13	3217-9	6	Nut-Hex
14	100-1438	8	Screw-Socket Head, Torx
15	3253-6	8	Washer-Lock/Sp
16	3296-39	8	Nut-Lock, NI
17	3256-4	8	Washer-Flat
18	99-0050-01	2	Spring Plate ASM
19	99-0052	8	Washer-Slide
20	100-1401	8	Spacer-Slide, Spring
21	99-0044	1	Roller-Front
25	10-7070	1	Key-Square

Ref. No.	Part No.	Qty.	Description

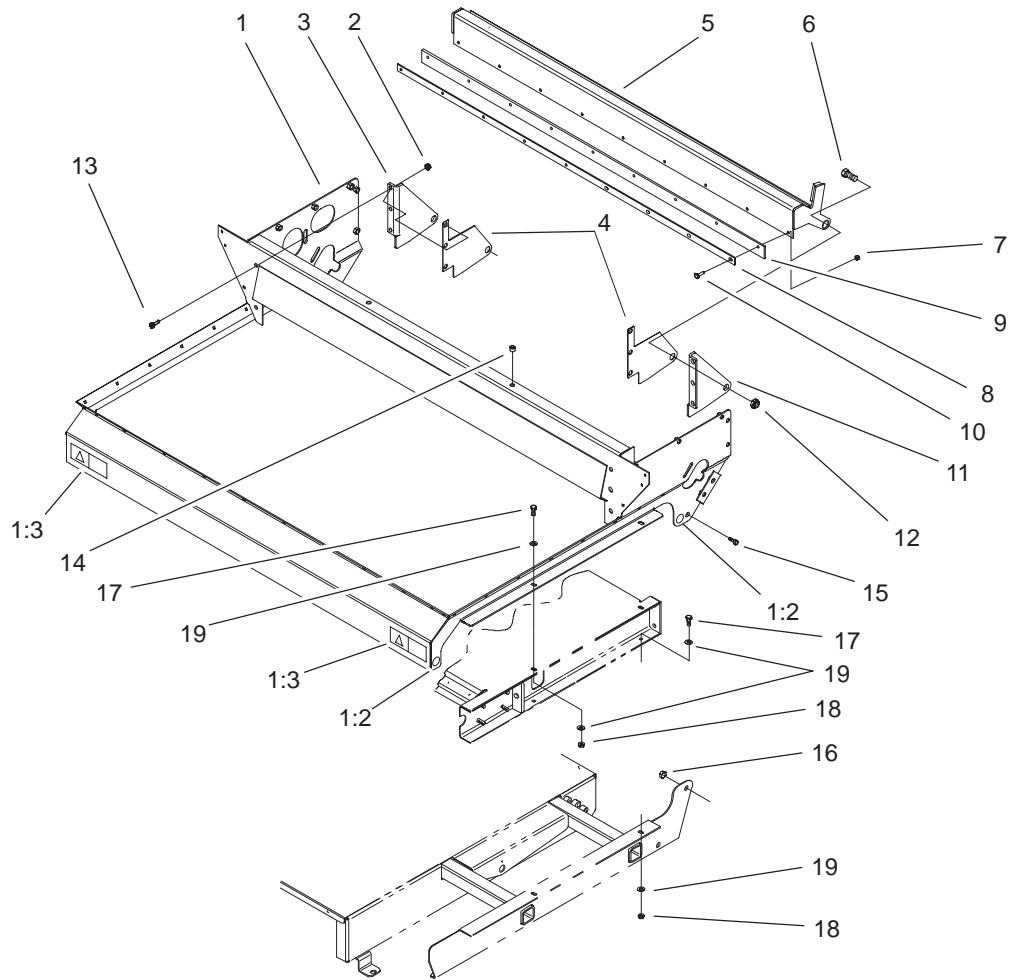

Sheet No.: 4

Gate Assembly

Ref. No.	Part No.	Qty.	Description	Ref. No.	Part No.	Qty.	Description
1	100-1435	1	Hopper Frame ASM				
1:2	58-6520	4	Decal-Grease				
1:3	93-9092	2	Decal-Warning				
2	32128-37	6	Nut-HF				
3	99-0079-01	1	Bracket-Gate Pivot, RH				
4	99-0117	2	Wareplate-Gate				
5	99-0068-01	1	Gate ASM				
6	328-24	2	Screw-HH				
7	3296-29	9	Nut-Lock, NI				
8	99-0089-01	1	Plate-Backing				
9	99-0074	1	Seal-Gate				
10	322-6	9	Screw-HH				
11	99-0078-01	1	Bracket-Gate Pivot, LH				
12	3296-51	2	Nut-Lock, NI				
13	324-4	6	Screw-HH				
14	32148-9	2	Nut-Insert				
15	325-2	2	Screw-HH				
16	3296-45	2	Nut-Lock, NI				
17	323-7	8	Screw-HH				
18	3296-39	8	Nut-Lock, NI				
19	3256-24	12	Washer-Flat				

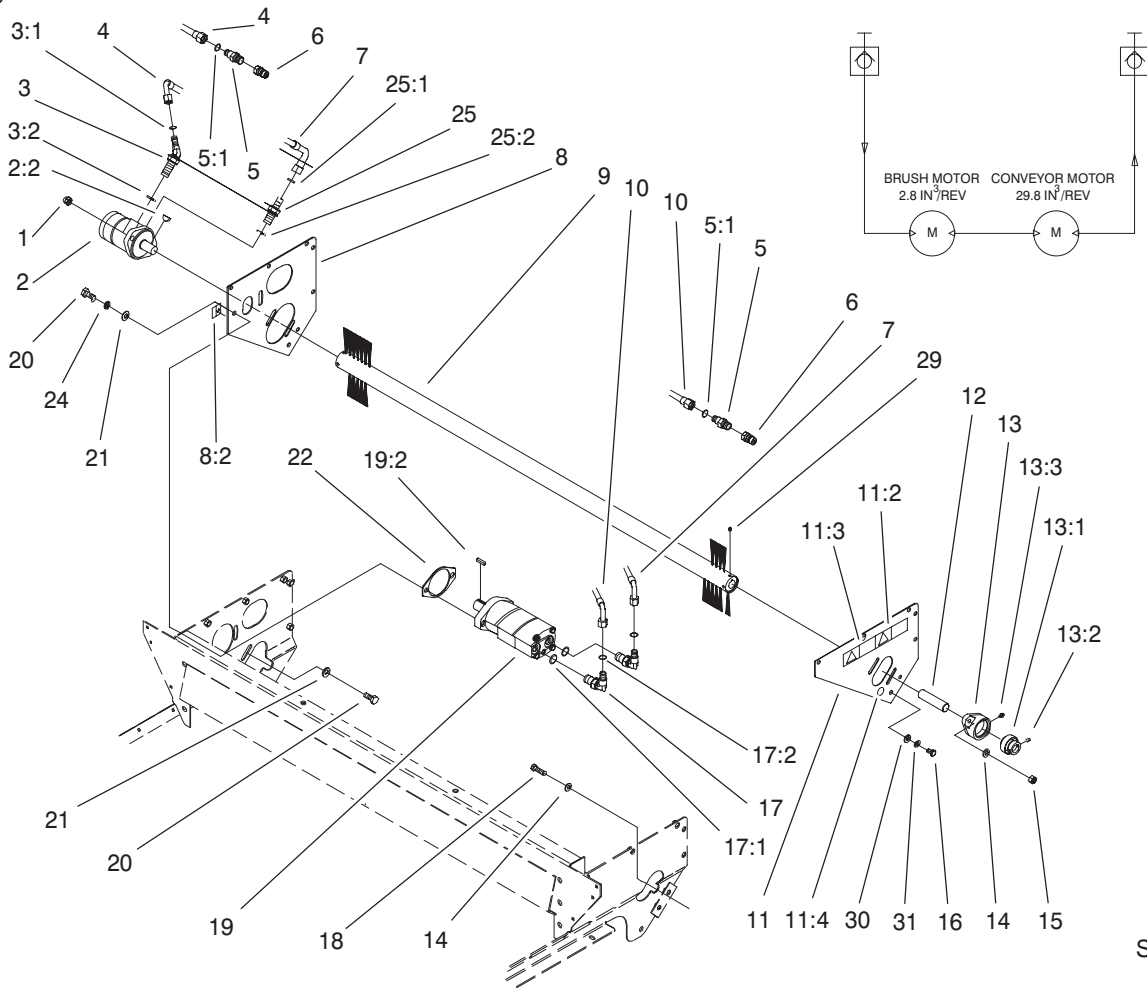

Sheet No.: 5
T-3279

Brush and Motor Assembly and Hydraulic Schematic

Ref. No.	Part No.	Qty.	Description
1	3296-45	2	Nut-Lock, NI
2	99-0156	1	Motor-Hydraulic
*2:1	100-1446	1	Kit-Seal
2:2	3257-43	1	Key-Woodruff
3	340-89	1	Fitting-45°
3:1	237-30	1	O-Ring
3:2	237-80	1	O-Ring
4	99-0191	1	Hose-Pressure
5	340-12	2	Fitting-Straight
5:1	237-30	1	O-Ring
6	92-2672	2	Coupling-Hydraulic
7	99-0177	1	Hose-Hydraulic
8	100-1431	1	RH Motor Brace ASM
8:2	98-3114	1	Decal-Warning, Ce
9	99-0162	1	Brush
10	99-0192	1	Hose-Return
11	100-1430	1	LH Motor Brace ASM
11:2	99-0015	1	Decal-Danger
11:3	93-9867	1	Decal-No Riders
11:4	58-6520	1	Decal-Grease
12	99-0041	1	Shaft-Brush
13	99-0160	1	Bearing
13:1	251-246	1	Collar w/Set Screws
13:2	3245-35	1	Screw-HS
13:3	302-2	1	Fitting-Grease
14	3256-25	4	Washer-Flat

Ref. No.	Part No.	Qty.	Description
15	3296-48	2	Nut-Lock NI
16	323-4	4	Screw-HH
17	340-105	2	Fitting-90°
17:1	237-30	1	O-Ring
17:2	237-80	1	O-Ring
18	324-6	2	Screw-HH
19	99-0155	1	Hydraulic Motor Conveyor ASM
*19:1	100-1447	1	Kit-Seal
19:2	10-7070	1	Key-Square
20	325-6	4	Screw-HH
21	3256-26	4	Washer-Flat
22	99-0116	1	Plate-Spacer
24	3253-7	2	Washer-Lock/Sp
25	340-6	1	Fitting-Straight
25:1	237-30	1	O-Ring
25:2	237-80	1	O-Ring
29	3246-3	4	Screw-HS
30	3256-24	4	Washer-Flat
31	3253-21	4	Washer-Lock

* Not illustrated

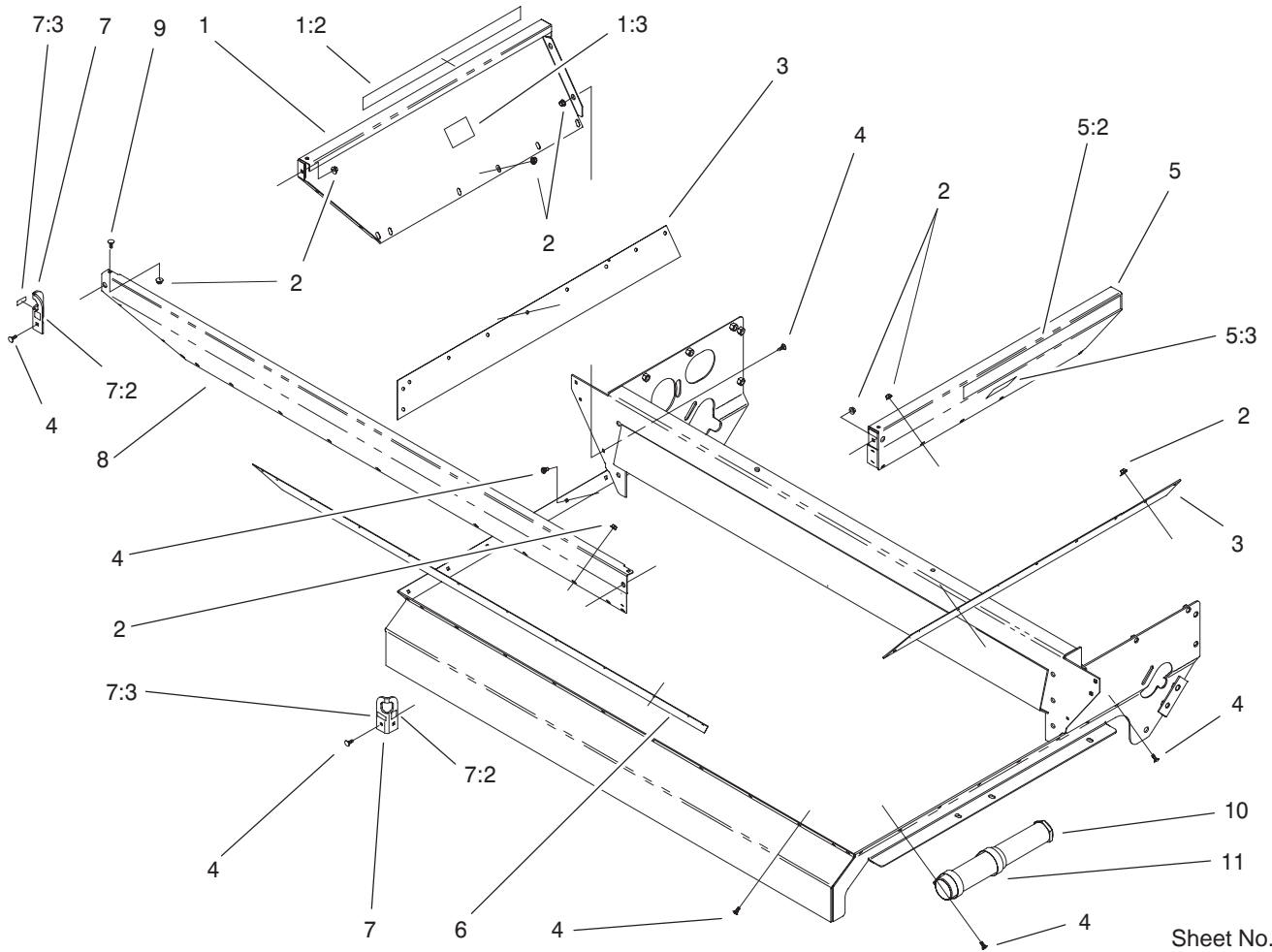

Sheet No.: 6

Hopper Assembly

Ref. No.	Part No.	Qty.	Description
1	100-1434	1	RH Hopper Panel ASM
1:2	99-0013	1	Decal-Topdresser, 1800
1:3	94-1235	1	Decal - Capacity
2	32128-33	44	Nut-HF
3	99-0142	2	Seal-Sand, Side
4	3229-25	40	Screw-CARR
5	100-1433	1	LH Hopper Panel ASM
5:2	99-0013	1	Decal-Topdresser, 1800
5:3	94-1235	1	Decal - Capacity
6	99-0143	1	Seal-Sand, Front
7	100-1428	2	Front Lift Eye ASM
7:2	93-9084	1	Decal-Point, Lift
7:3	93-9529	1	Decal-Value, Kg
8	99-0020	1	Panel - Hopper, Front
9	321-4	4	Screw-HH
10	74-0720	1	Tube-Manual
11	2412-133	2	R-Clamp

Ref. No.	Part No.	Qty.	Description

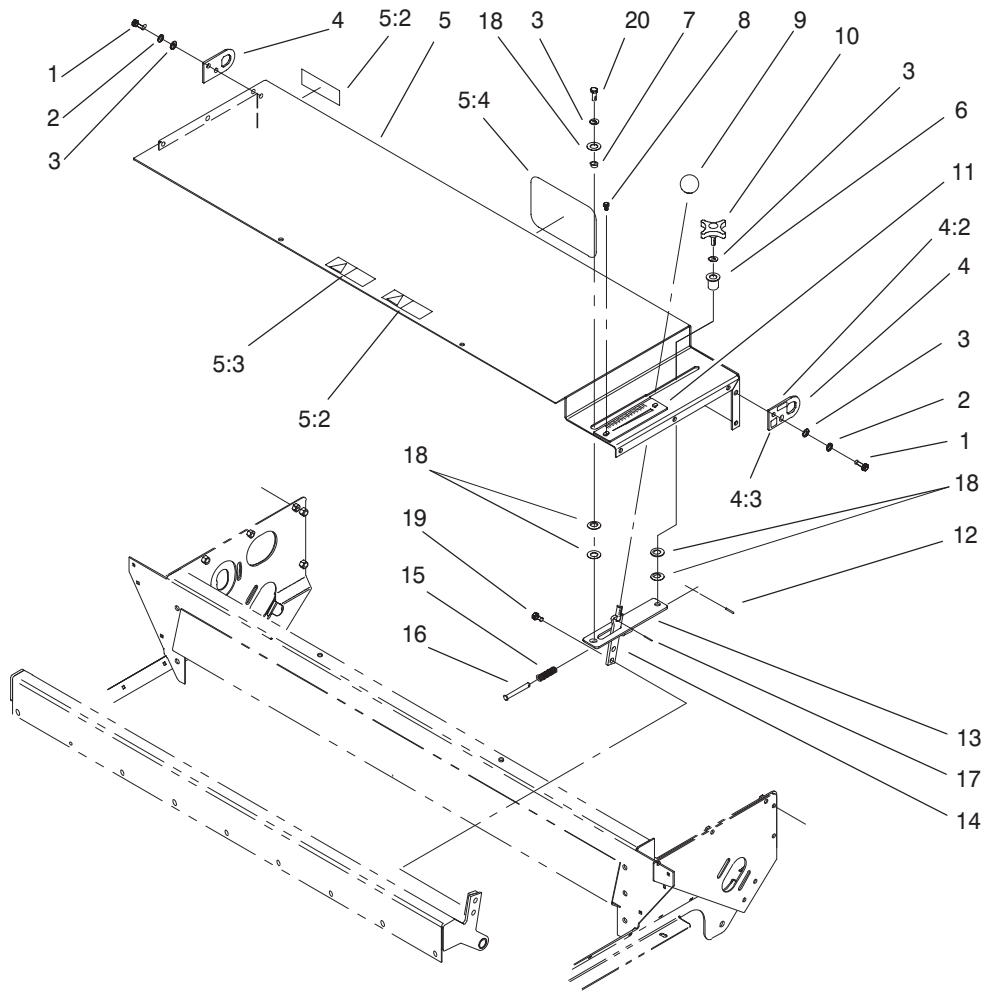

Sheet No.: 7

Gate Slide and Brush Guard Assembly

Ref. No.	Part No.	Qty.	Description
1	323-7	12	Screw-HH
2	3253-21	12	Washer-Lock
3	3256-24	13	Washer-Flat
4	100-1429	2	Rear Lift Eye ASM
4:2	93-9529	2	Decal-Value, Kg
4:3	93-9084	2	Decal-Point, Lift
5	100-1432	1	Brush Guard ASM
5:2	99-0015	2	Decal-Danger
5:3	93-9867	1	Decal-No Riders
5:4	92-1242	1	Decal-Toro
6	95-4896	1	Washer-Nylon
7	256-259	1	Bushing-Flange
8	93-6083	2	Screw-HWH
9	233-48	1	Knob
10	100-1449	1	Knob
11	100-1416	1	Plate-Gate
12	32121-45	1	Pin-Spring
13	99-0073-03	1	Slide Block Plate ASM
14	100-1406-03	1	Gate Handle ASM
15	100-1448	1	Spring-Gate
16	100-1413	1	Pin-Clevis
17	32121-40	1	Pin-Spring
18	99-0052	5	Washer-Slide
19	323-4	2	Screw-HH
20	3274-63	1	Screw-HSH

Ref. No.	Part No.	Qty.	Description

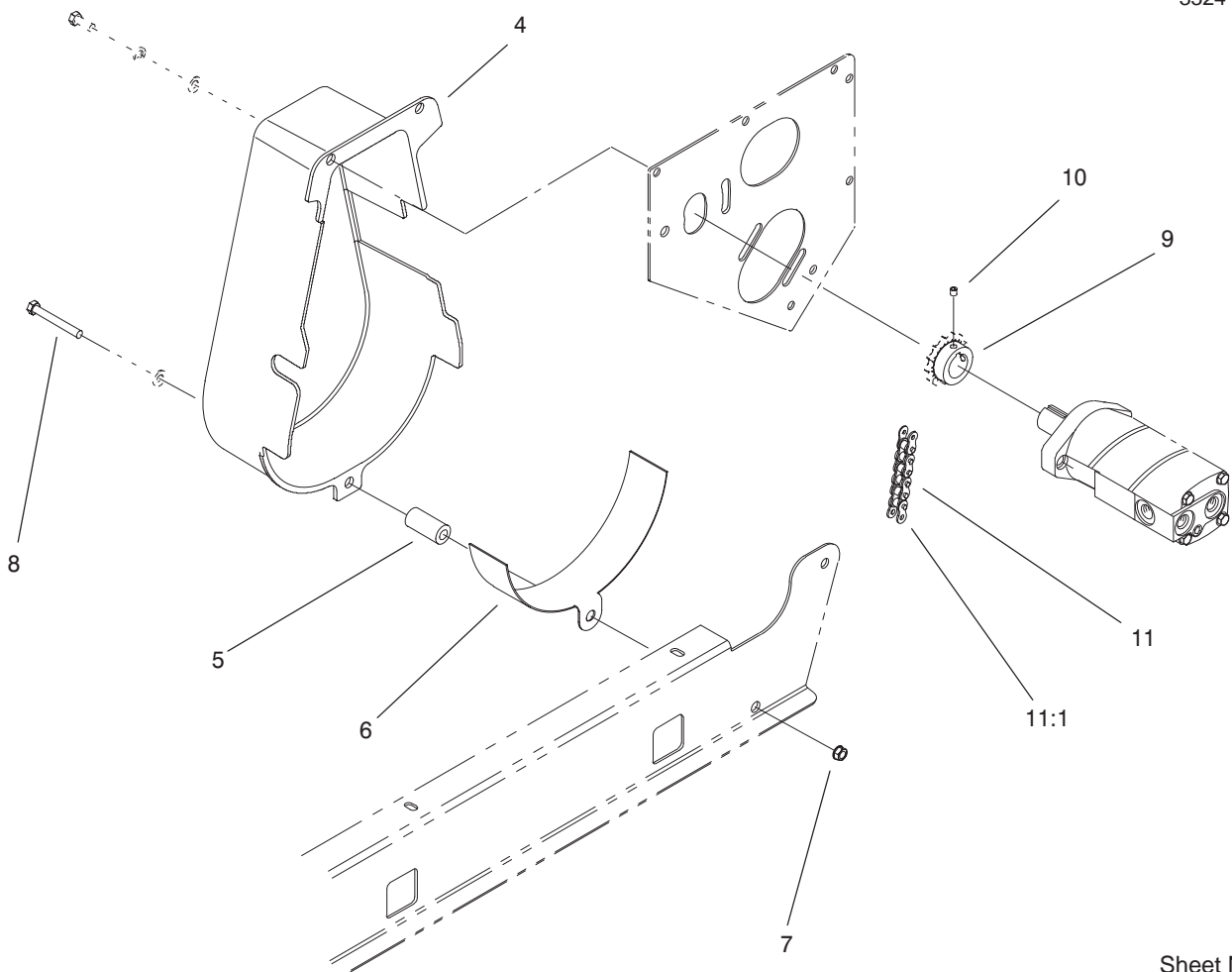

Sheet No.: 8

Chain, Sprocket, and Guard Assembly

Ref. No.	Part No.	Qty.	Description
4	99-0171	1	Guard-Chain & Sprockets
5	100-1442	1	Spacer-Guard
6	100-1450-03	1	Finger Guard ASM
7	3296-39	1	Nut-Lock, NI
8	323-14	1	Screw-HH
9	99-0165-03	1	Sprocket-Drive
10	3246-3	2	Screw-HS
11	99-0164	1	Chain-Roller
11:1	2710-16	1	Link-chain

Ref. No.	Part No.	Qty.	Description

