

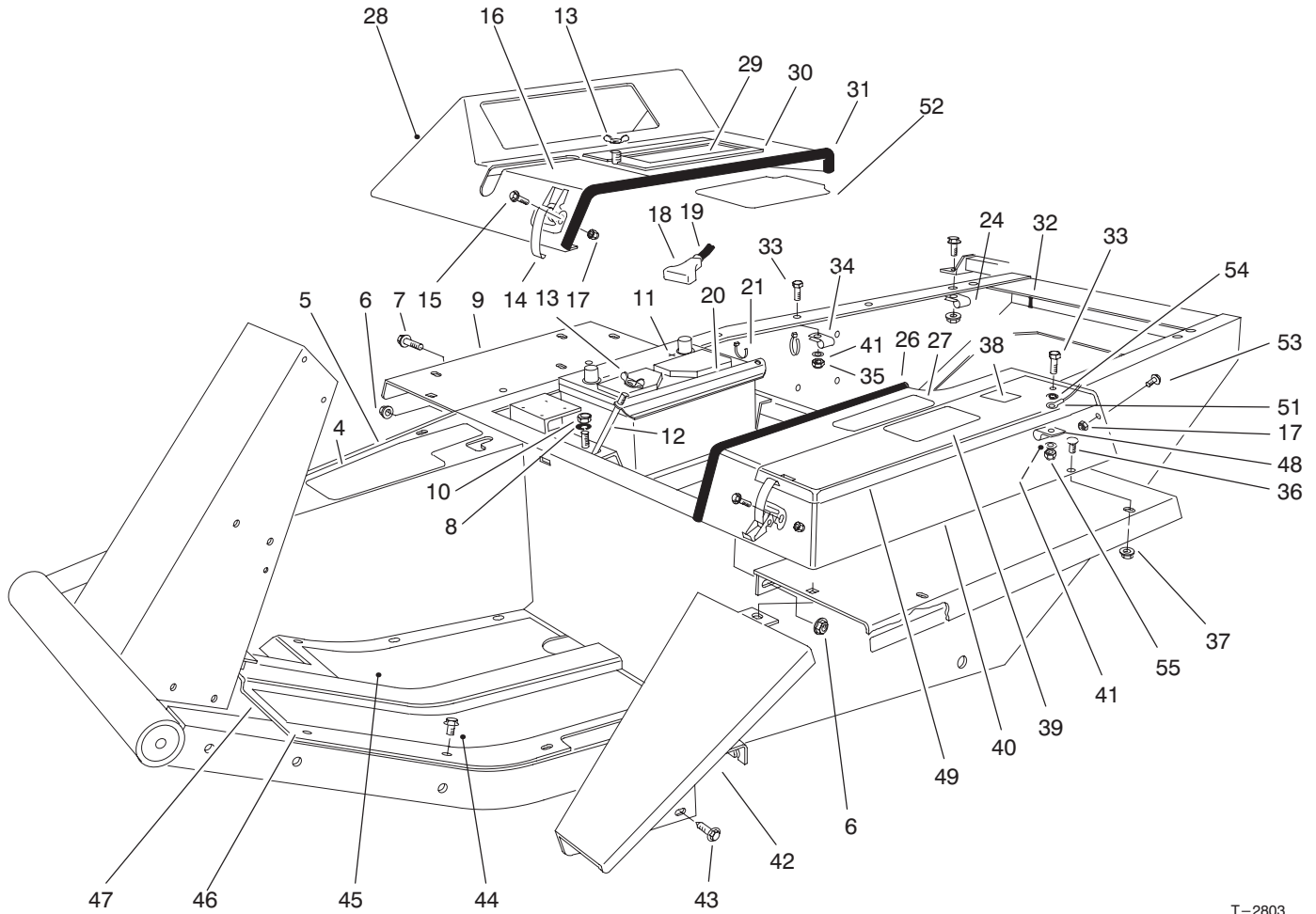

Model NO. 30789-20000301 & Up

PARTS CATALOG

GROUNDMASTER® 345
TRACTION UNIT



T-2803

Main Frame Assembly

Ref. No.	Part No.	Description	No. Used
4	66-6390	Decal-Caution	1
5	21-2660	Footrest	1
6	32128-19	Nut-Flange	6
7	3234-12	Screw-HHF	4
8	3253-4	Washer-Lock	2
9	72-3690	Fender	2
10	3217-6	Nut	2
11	55-7290	Battery (Group Size 24)	1
12	24-6390	Stud-Battery Hold Down	2
13	32103-2	Nut-Wing	2
14	249-21	Hook Clamp	3
15	3290-144	Screw-Machine	6
16	27-7290	Decal-Power Take Off	1
17	3296-2	Nut-Lock	9
18	28-1280	Boot-Cable	1
†19		Cable-Battery Positive	1
20	24-6420	Hold Down-Battery	1

Ref. No.	Part No.	Description	No. Used
21	3290-378	Cable Tie	2
23	3234-11	Capscrew w/Locking Flange	5
24	2412-39	Clamp	2
25	3290-357	Nut-Lock, Flange	5
26	37-9650	Trim	1
27	67-1710	Decal-Caution	1
28	38-4550	Instrument Cover	1
29	92-7802	Decal-Starting Instructions	1
30	92-7800	Cover-Battery Access (Incl. Ref. #29 & 52)	1
31	39-8020	Trim-Instrument Cover	1
32	43-4300	Trim-Rear Frame	2
33	322-6	Screw-HH	1
34	2412-74	Clamp	1
35	3296-39	Nut-Lock	1
36	3229-1	Bolt-Carriage	5

† Obtain Locally

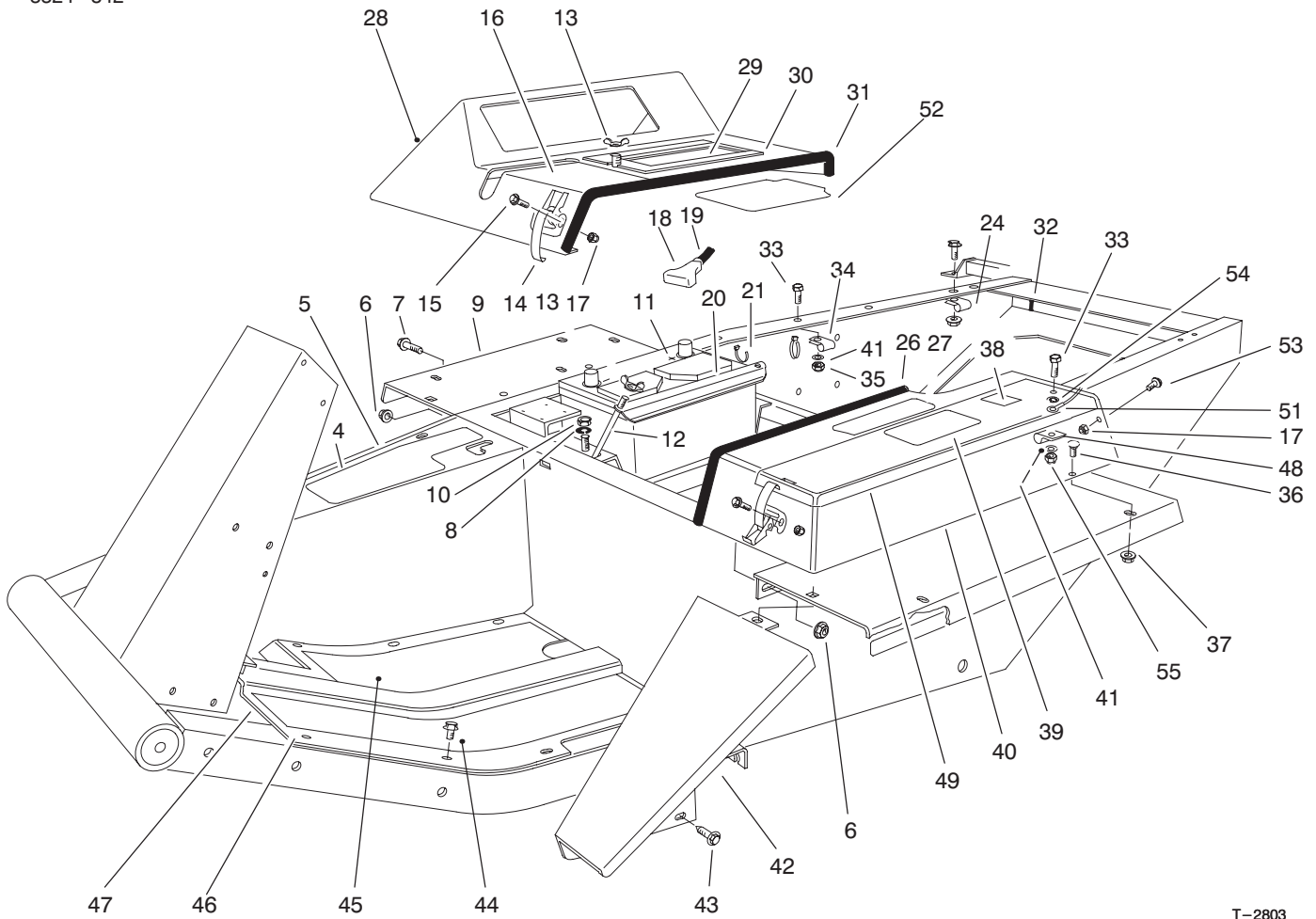

T-2803

Main Frame Assembly (Continued)

Ref. No.	Part No.	Description	No. Used
37	32128-13	Nut-Lock, Flange	5
38	53-4420	Decal-Fuel	1
39	27-7310	Decal-Refueling	1
40	93-3183	Tool Box (Incl. Ref. #27)	1
41	3256-23	Washer-Flat	1
42	68-8610	Fender-Extension	1
43	3234-14	Screw-HH	2
44	32144-10	Screw-Self Tapping	11
45	21-2770	Pad-Foot Rest RH	1

Ref. No.	Part No.	Description	No. Used
46	21-2760	Pad-Foot Rest LH	1
47	88-0070	Floor Plate	1
48	98-3883	Clamp-Wire	1
49	93-3184	Cover (Incl. Ref. # 39)	1
51	18-2770	Cable-Ground	1
52	92-7801	Shield-Cover, Battery	1
53	3290-144	Screw-HH	4
54	3254-2	Washer-Lock	1
55	3296-29	Nut-Lock	1

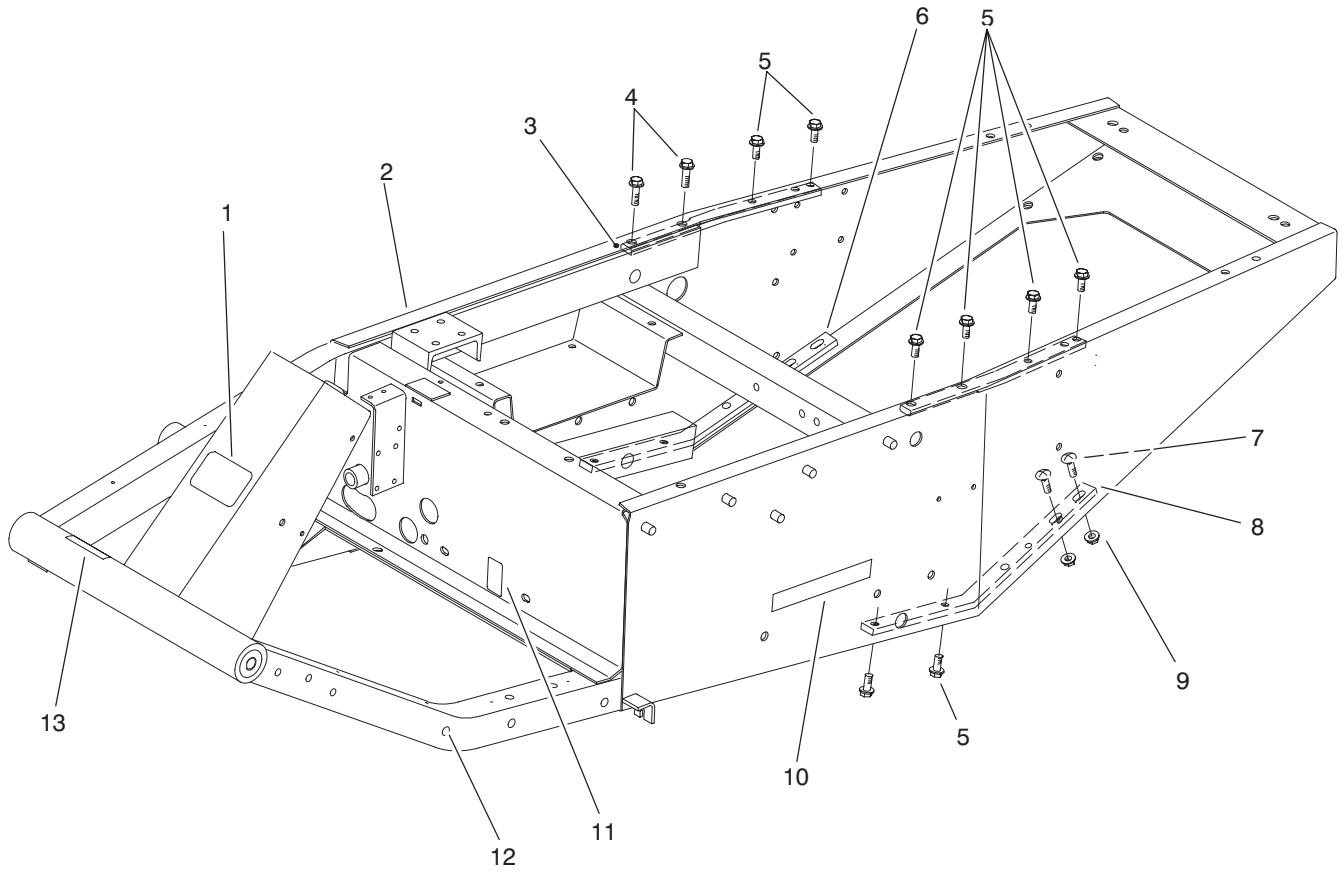

T-2802

Main Frame Assembly (Continued)

Ref. No.	Part No.	Description	No. Used	Ref. No.	Part No.	Description	No. Used
1	70-2200	Decal-Toro	1	7	3231-25	Screw-Carriage	4
2	98-3879	Asm-Frame (Incl. Ref. #1, & 3-13)	1	8	98-3864	Brace-Lower Left	1
3	98-3866	Brace-Upper	2	9	32128-21	Nut-Lock HFH	4
4	3234-24	Screw-HHF	2	10	67-1720	Decal-Torque	2
5	3234-25	Screw-HHF	10	11	53-4430	Decal-Oil Fill	1
6	98-3865	Brace-Lower Right	1	12	32148-9	Insert-Threaded	1
				13	27-7320	Decal-Traction Pedal	1

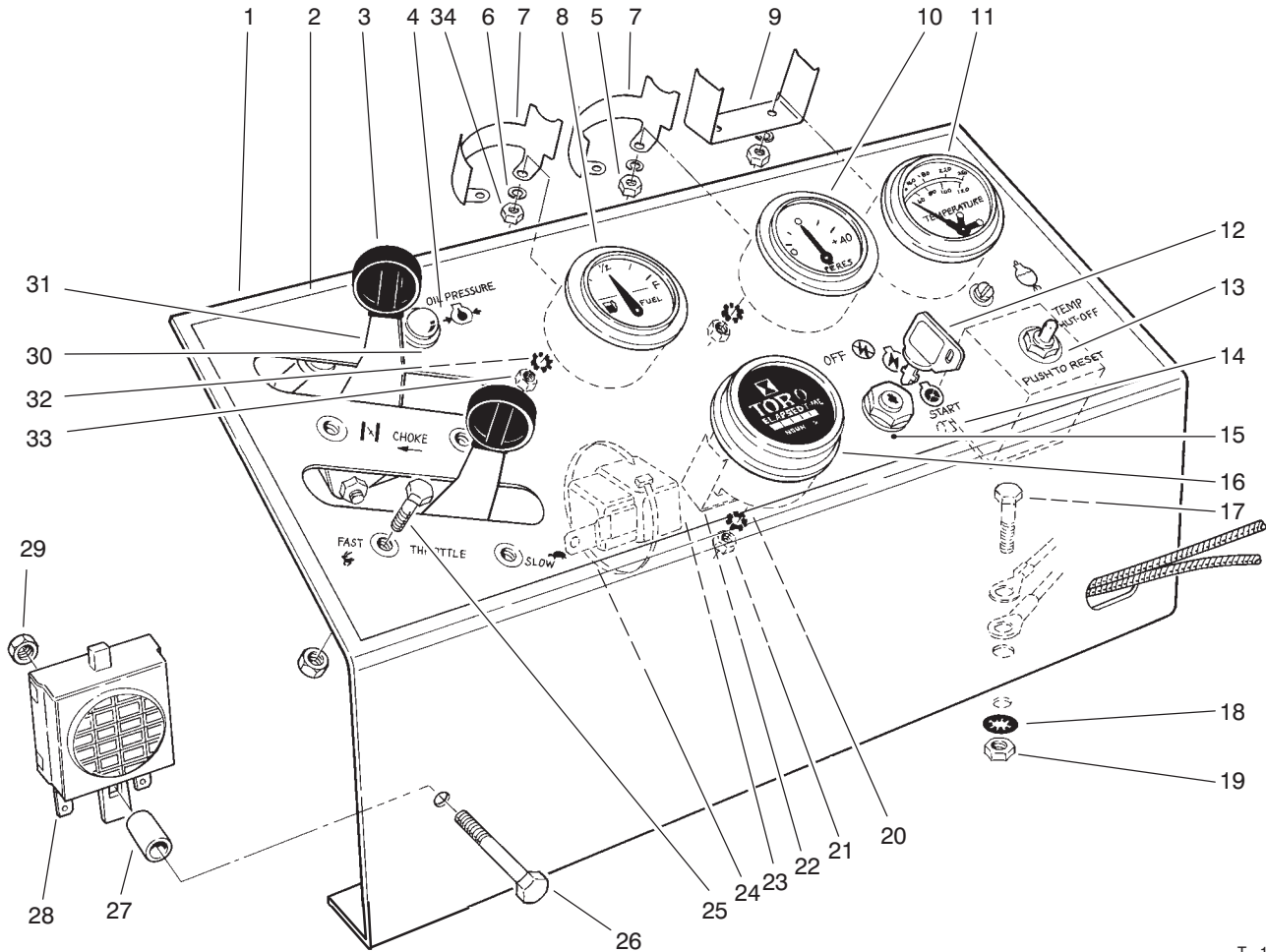

T-1175-1

Instrument Panel Assembly

Ref. No.	Part No.	Description	No. Used
1	86-9370	Panel-Instrument	1
2	85-7470	Decal-Instrument Panel	1
3	233-35	Knob-Control	2
4	218-533	Lens	1
5	3219-14	Nut	4
6	3254-1	Washer-Lock	6
7	38-1670	Mounting Clamp	2
8	38-1650	Fuel Gauge (Incl. Ref. #5-7, 32 & 33)	1
9	218-539	Clamp	1
10	38-1660	Ammeter (Incl. Ref. #5-7, 32 & 33)	1
11	67-8550	Engine Temperature Gauge (Incl. Ref. #5, 6 & 9)	1
12	63-8360	Key	1
13	26-6740	Temperature Reset Relay	1
†14		Fuse Temp. Relay 14 amp SFE	1
15	27-2360	Switch	1
16	12-9990	Hour Meter (Incl. Ref. #20-22)	1

Ref. No.	Part No.	Description	No. Used
17	322-5	Screw-HH	2
18	3254-2	Washer-Lock, Int. Tooth	6
19	3217-6	Nut	2
20	3255-5	Washer-Lock	1
21	3217-26	Nut-Hex.	1
22	218-515	Mounting Bracket	1
23	63-7590	Relay	1
24	3290-379	Cable Tie	A/R
25	3290-134	Screw Machine Hex. Hd.	4
26	3290-360	Screw Machine Hex. Hd.	1
27	22-7810	Spacer	1
28	22-7820	Asm-Buzzer	1
29	3296-12	Nut-Lock	5
30	44-2210	Warning Light (Incl. Ref. #4)	1
31	67-8560	Throttle & Choke Control (Incl. Ref. #3)	2
32	3255-24	Washer-Lock	5
33	3217-29	Nut-Hex.	6
34	3217-27	Nut-Hex.	2

†Obtain Locally

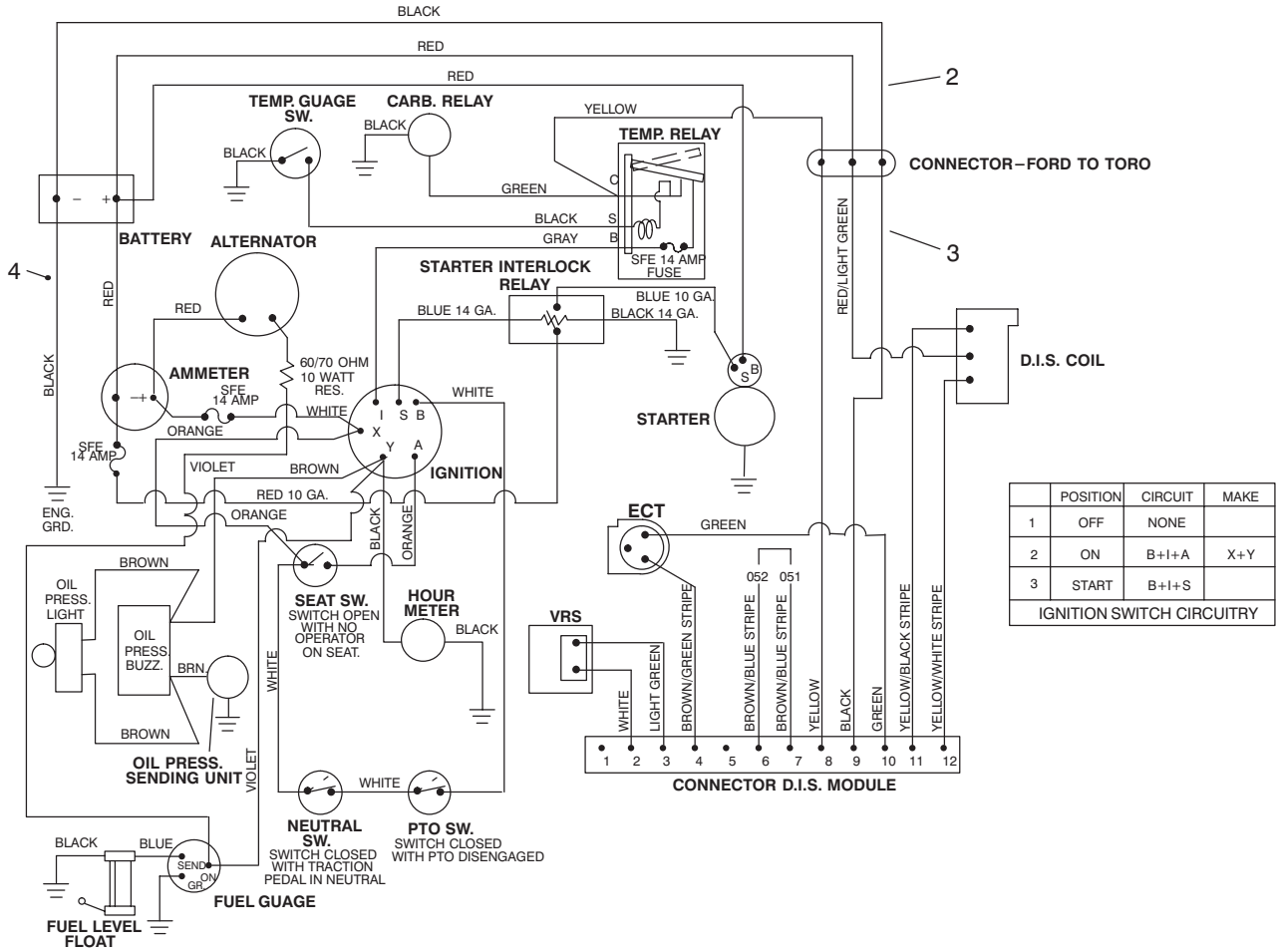

T-0915-1

Electrical Schematic

Ref. No.	Part No.	Description	No. Used
2	93-9741	Asm-Wire-Harness	1

Ref. No.	Part No.	Description	No. Used
†3	E9JL-12A200-AC	Wire-Harness (Ford)	1
4	67-8540	Cable-Ground	1

†Obtain from your local Ford Power Products Dealer.

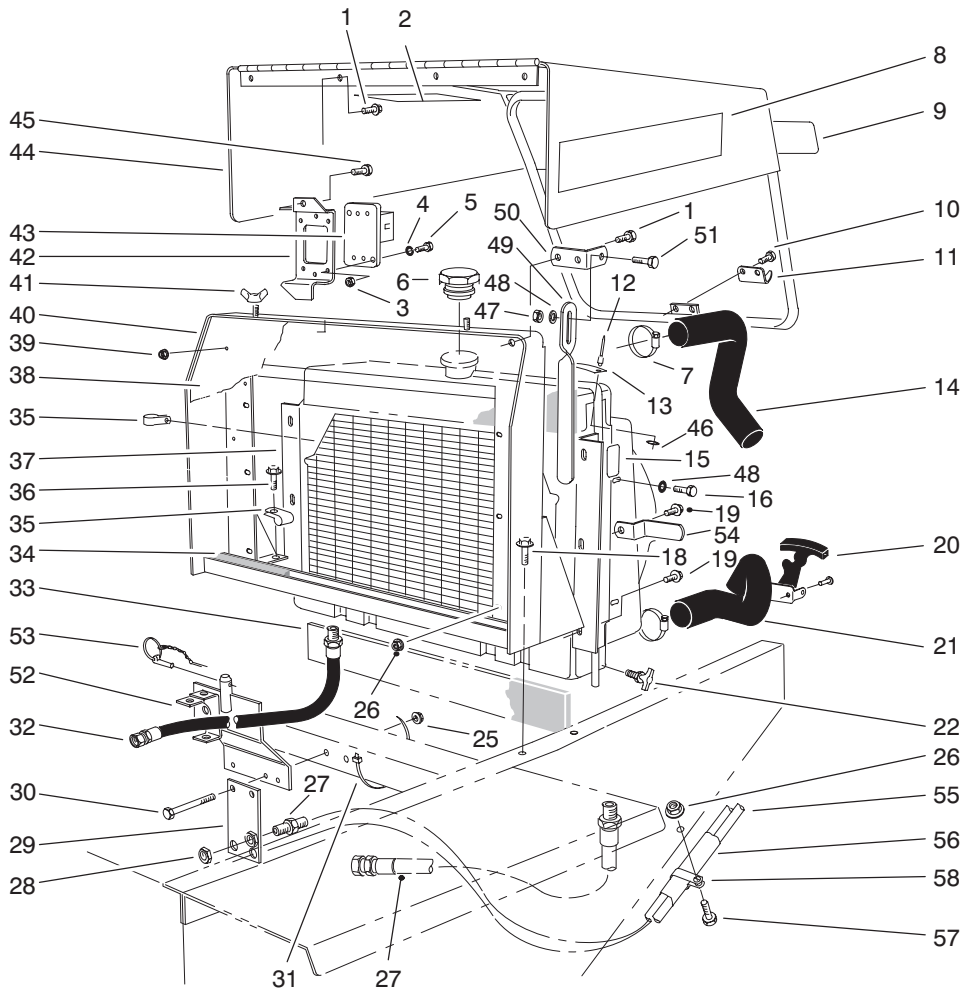

T-0916-4

Radiator & Hood Assembly

Ref. No.	Part No.	Description	No. Used
1	32144-10	Screw-TAP	5
2	82-8970	Decal-Coolant Engine	1
3	48-7890	Nut-Metric	2
4	43-5930	Washer-Metric	2
5	48-7630	Screw-Metric	2
6	66-3240	Cap-Pressure Radiator	1
7	2412-3	Clamp-Hose	4
8	93-3189	Decal-Groundsmaster 345	2
9	66-6140	Decal-Toro	1
10	3290-55	Rivet	4
11	249-40	Keeper	1
12	3269-13	Rivet	2
13	76-8750	Decal-Warning	1
14	70-1630	Hose-Radiator Upper	1
15	77-3100	Decal-Warning	2
16	32104-109	Screw-HHF	4
17	67-8640	Shroud-Radiator	1
18	3234-25	Screw-HHF	1
19	3234-14	Screw-HHF	6
20	59-9740	Latch-Draw (Inc. Ref. #11)	1
21	67-8660	Hose-Radiator Lower	1
22	304-46	Draincock	1
24	63-9010	Asm-Hose (Cooler to Pump)	1
25	32128-21	Nut-HF	3

Ref. No.	Part No.	Description	No. Used
26	32128-20	Nut-HF	7
27	340-71	Union-Bulkhead	2
28	340-70	Nut-Lock, Bulkhead	2
29	68-9160	Bracket	1
30	323-14	Screw-HH	3
31	3290-379	Tie-Cable	A/R
32	63-8960	Asm-Hose	1
33	43-3320	Foam-Radiator	2
34	70-1790	Strip-Foam Sealing	1
35	2412-39	Clamp	2
36	3234-24	Screw-HHF	2
37	67-8590	ASM-Radiator	1
38	67-9030	Grille-Radiator	1
39	32128-33	Nut-Lock, Flange	2
40	86-9400	Support-Radiator	1
41	32103-2	Nut-Wing	2
42	70-1660	Bracket-E.S.C.	1
†43		Module-E.S.C.	1
44	14-8459	Hood	1
45	321-39	Screw-HH	2
46	3269-10	Washer	2
47	3296-16	Nut-Lock	1
48	3256-22	Washer-Flat	5
49	84-5380	Strap-Hood Prop	1
50	84-5330	Bracket-Hood Prop	1
51	321-6	Screw-HH	1

†Obtain from your local Ford Power Products Dealer.

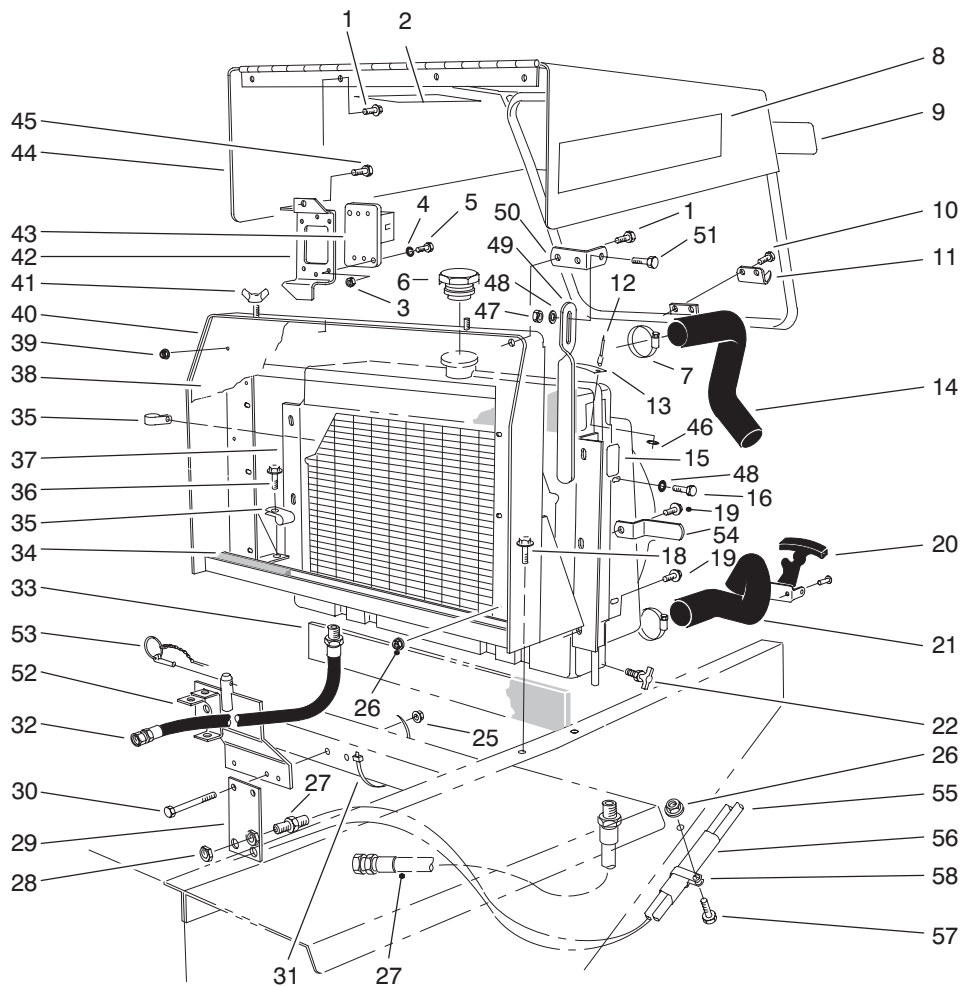

T-0916-4

Radiator & Hood Assembly (Continued)

Ref. No.	Part No.	Description	No. Used	Ref. No.	Part No.	Description	No. Used
52	86-9410	Support-Seat	1	56	56-7980	Sleeve-Protective	1
53	283-76	Pin-Lynch	1	57	322-6	Screw-HH	1
54	86-7060	Bracket-Hood Hold Down	1	58	2412-147	Clamp	1
55	68-9710	Hose-Steering Cylinder	2				

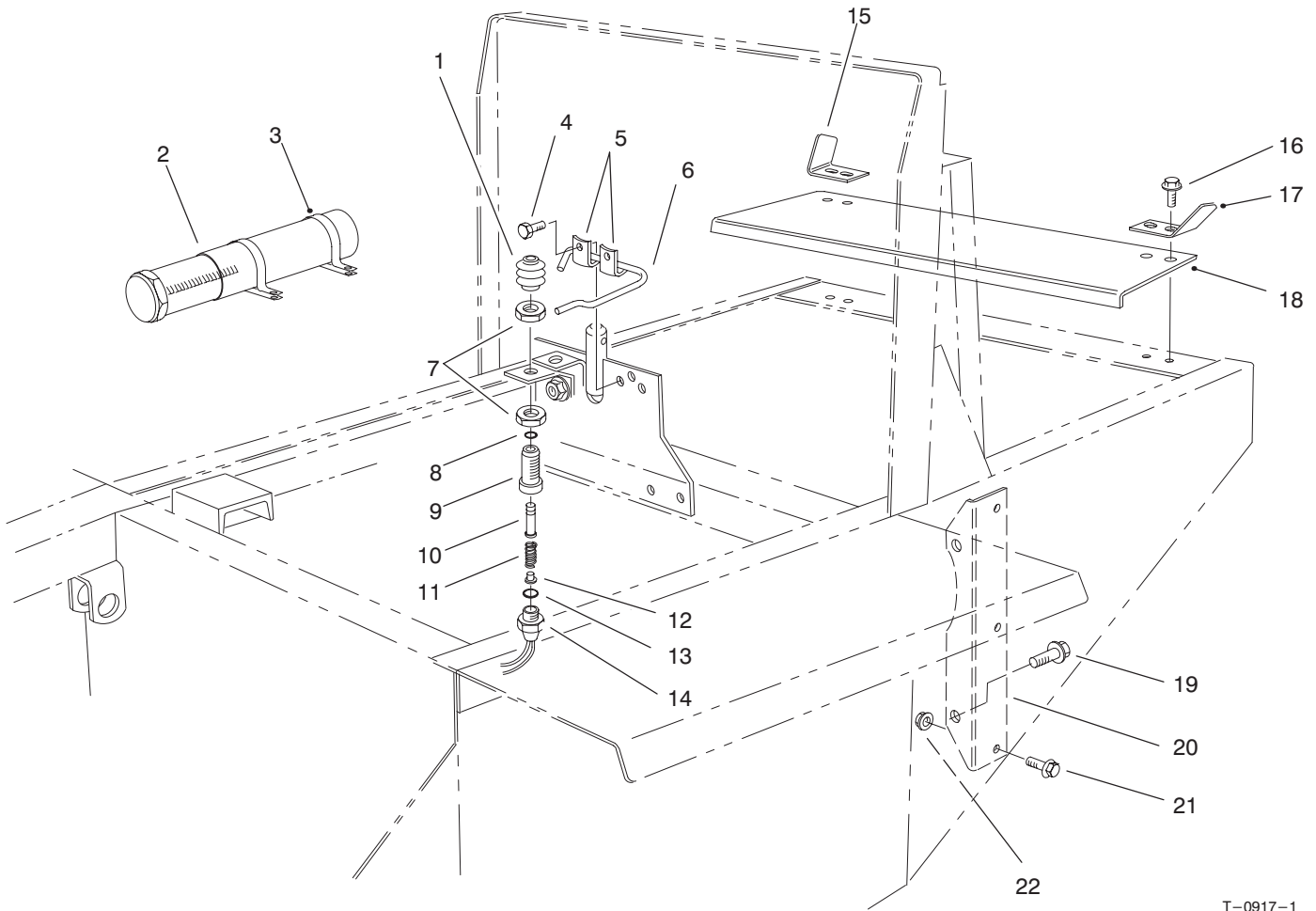

T-0917-1

Interlock Assembly

Ref. No.	Part No.	Description	No. Used
1	43-8870	Boot-Switch	1
2	74-0720	Tube-Manual	1
3	2412-133	R-Clamp	2
4	32144-10	Screw-TAP	2
5	3-6657	Clip	2
6	86-7040	Rod-Seat Prop	1
7	218-461	Nut-Jam	2
8	237-7	O-Ring	1
9	43-8620	Guide-Switch Pin	1
10	43-8860	Plunger-Switch	1
11	43-8600	Spring-Compression	1
12	43-8610	Guide-Spring & Ball Seat	1
13	237-30	O-Ring	1

Ref. No.	Part No.	Description	No. Used
14	72-4320	Switch-Ball	1
15	62-3010	Bracket-RH	1
16	3234-17	Screw-HHF	4
17	62-3020	Bracket-LH	1
18	70-1890	Guard-Flywheel	1
19	3234-6	Screw-HHF	2
20	67-8190	Bracket-Engine Support	2
21	3234-11	Screw-HHF	6
22	3290-357	Nut-Lock, Flange	6
*	43-9071	Asm-Switch (Incl. Ref.#1, 7-14, Qty. 1 of Item #7)	1

*Not Illustrated

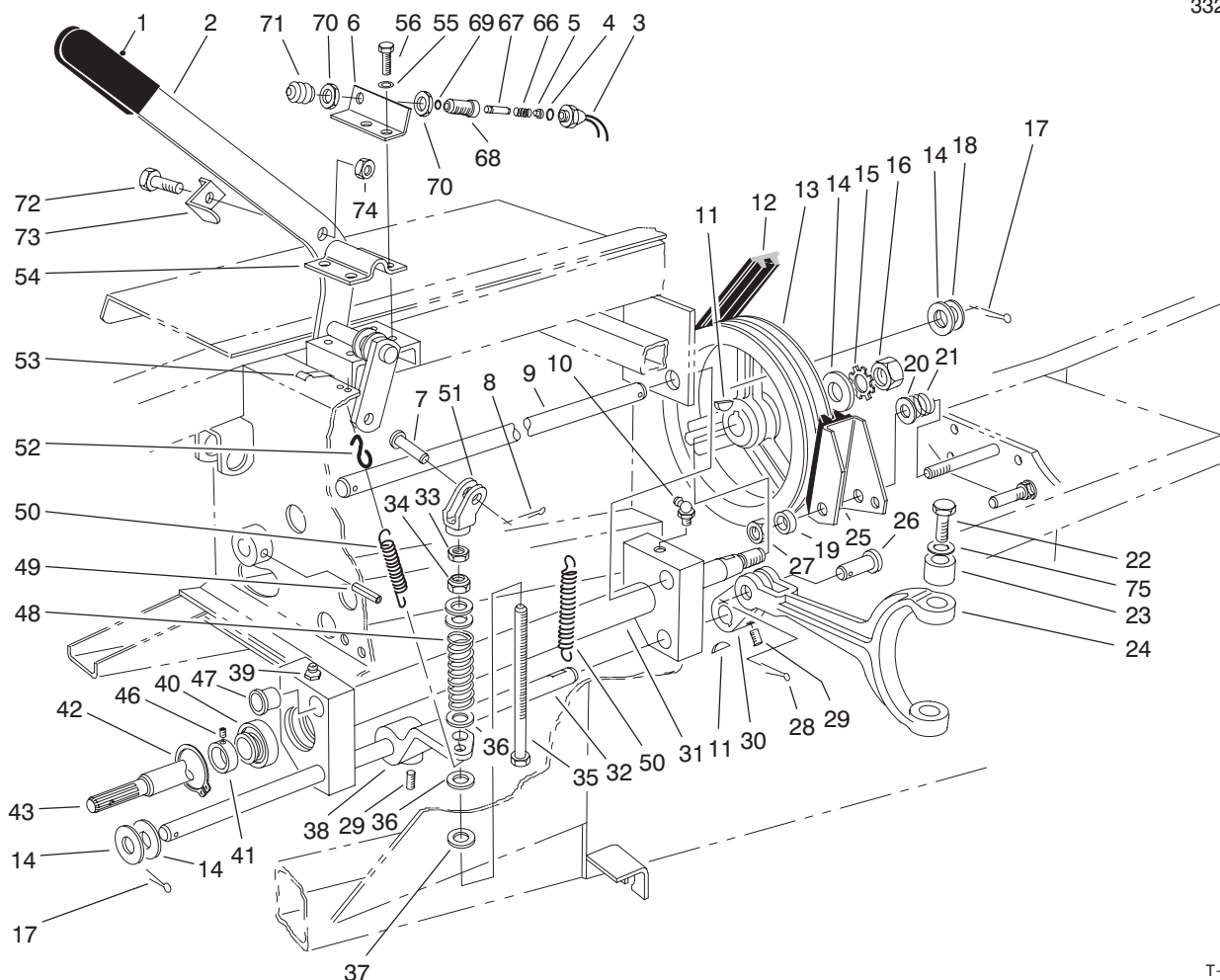

T-0413-3

Power Take Off Assembly

Ref. No.	Part No.	Description	No. Used	Ref. No.	Part No.	Description	No. Used
1	21-1880	Grip Handle	1	27	3296-28	Nut-Lock	1
2	84-8500	Lever-P.T.O.	1	28	3272-11	Pin-Cotter	1
3	72-4320	Switch-Ball	1	29	3246-3	Screw-Set	4
4	237-30	O-Ring	1	30	92-4058	Arm-P.T.O.	1
5	43-8610	Guide-Spring & Ball Seat	1	31	43-5500	Pivot P.T.O.	1
6	84-8520	Bracket-P.T.O. Switch	1	32	43-5550	Shaft- P.T.O. Actuator	1
7	283-42	Clevis Pin	1	33	3219-3	Nut	1
8	3272-6	Cotter Pin	1	34	3296-6	Nut-Lock	1
9	43-3860	Shaft-Pivot P.T.O.	1	35	27-7900	Screw-Adjusting	1
10	302-10	Fitting-Grease	1	36	3256-41	Washer-Flat	4
11	3257-5	Key-Woodruff	3	37	5-0652	Spacer	1
12	53-9660	V-Belt Torque Team	1	38	43-5570	Arm-P.T.O. Actuator	1
13	21-0230	Pulley- P.T.O.	1	39	302-2	Grease Fitting	1
14	3256-28	Washer-Flat	4	40	251-252	Ball Bearing (Incl. Ref. #41)	2
15	3254-7	Washer-Lock	1	41	251-234	Lock Collar (Incl. Ref. #46)	2
16	3219-7	Nut-Hex.	1	42	32120-22	Ring-Retaining	2
17	3272-22	Pin-Cotter	2	43	43-5540	Shaft P.T.O.	1
18	3-6498	Washer	A/R	44	62-4260	Asm-Drive Shaft	1
19	3-8812	Spacer	1	46	3246-1	Screw-Set	2
20	3256-6	Washer-Flat	1	47	256-113	Bushing-Flange	4
21	5-1747	Spring	1	48	21-0400	Spring-Compression	1
22	92-5727	Screw-HH	2	49	32121-9	Pin-Roll	1
23	92-5723	Bushing-P.T.O. Fork	2	50	21-1830	Spring-Tension	2
24	92-4060	Fork P.T.O.	1	51	43-5630	Yoke-P.T.O.	1
25	27-7370	Asm-Brake, P.T.O.	1				
26	93-3769	Clevis Pin	1				

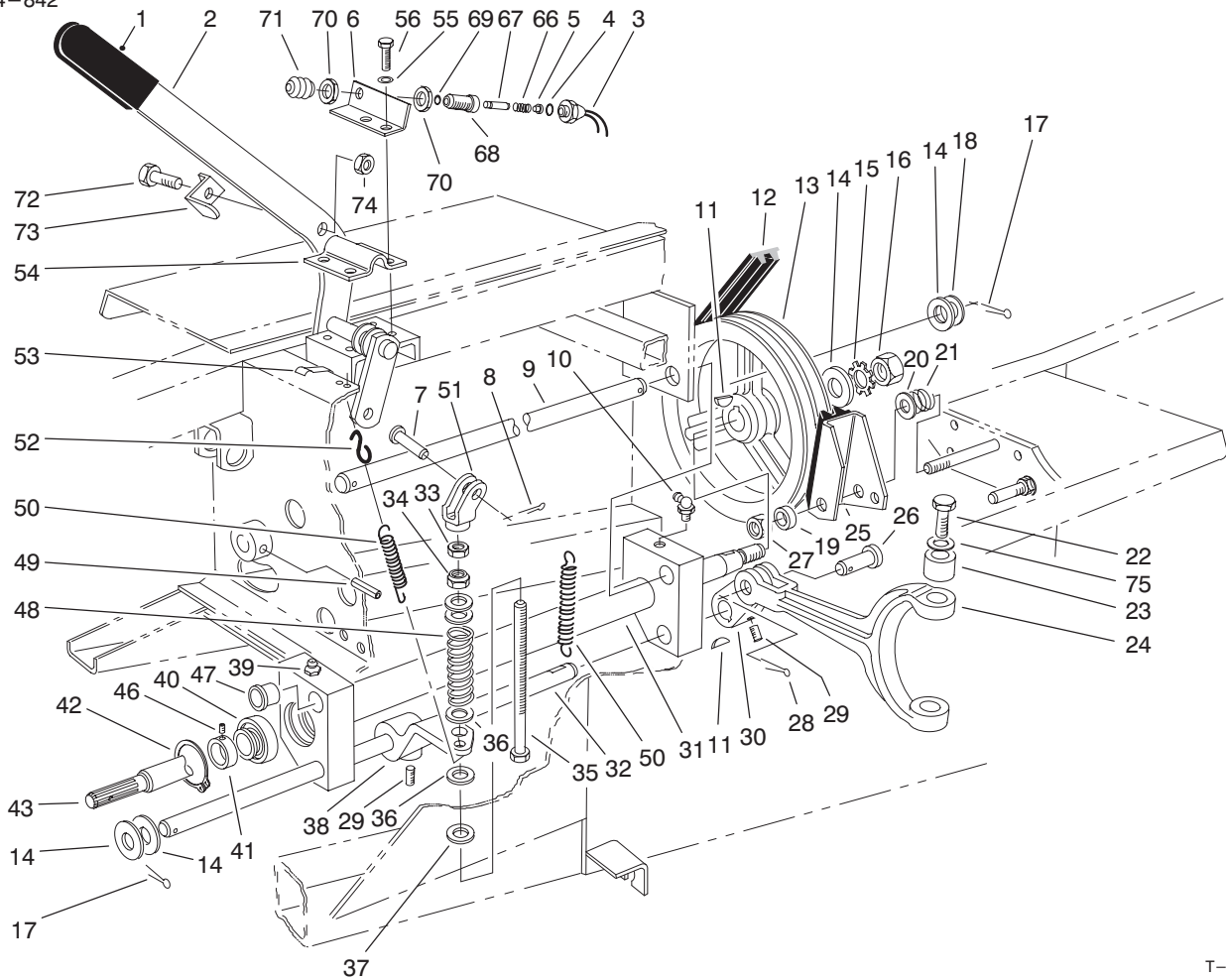

T-0413-3

Power Take Off Assembly (Continued)

Ref. No.	Part No.	Description	No. Used
52	5-0701	Spring Anchor	1
53	212-93	Wire Clip	1
54	21-1600	Clamp P.T.O. Lever	1
55	3253-21	Washer-Lock	4
56	32104-6	Screw-TAP	4
66	43-8600	Spring-Compression	1
67	43-8860	Plunger-Switch	1
68	43-8620	Guide-Switch Pin	1
69	237-7	O-Ring	1

Ref. No.	Part No.	Description	No. Used
70	218-461	Nut-Jam	2
71	43-8870	Boot-Switch	1
72	321-4	Screw-HH	1
73	86-7050	Bracket-Switch Actuator	1
74	3296-16	Nut-Lock	1
75	75-9890	Washer-Shim	A/R
*	43-9071	Asm-Switch (Incl. Ref. #3-5 & 66-71) (Qty. 1 of Item #70)	1

*Not Illustrated

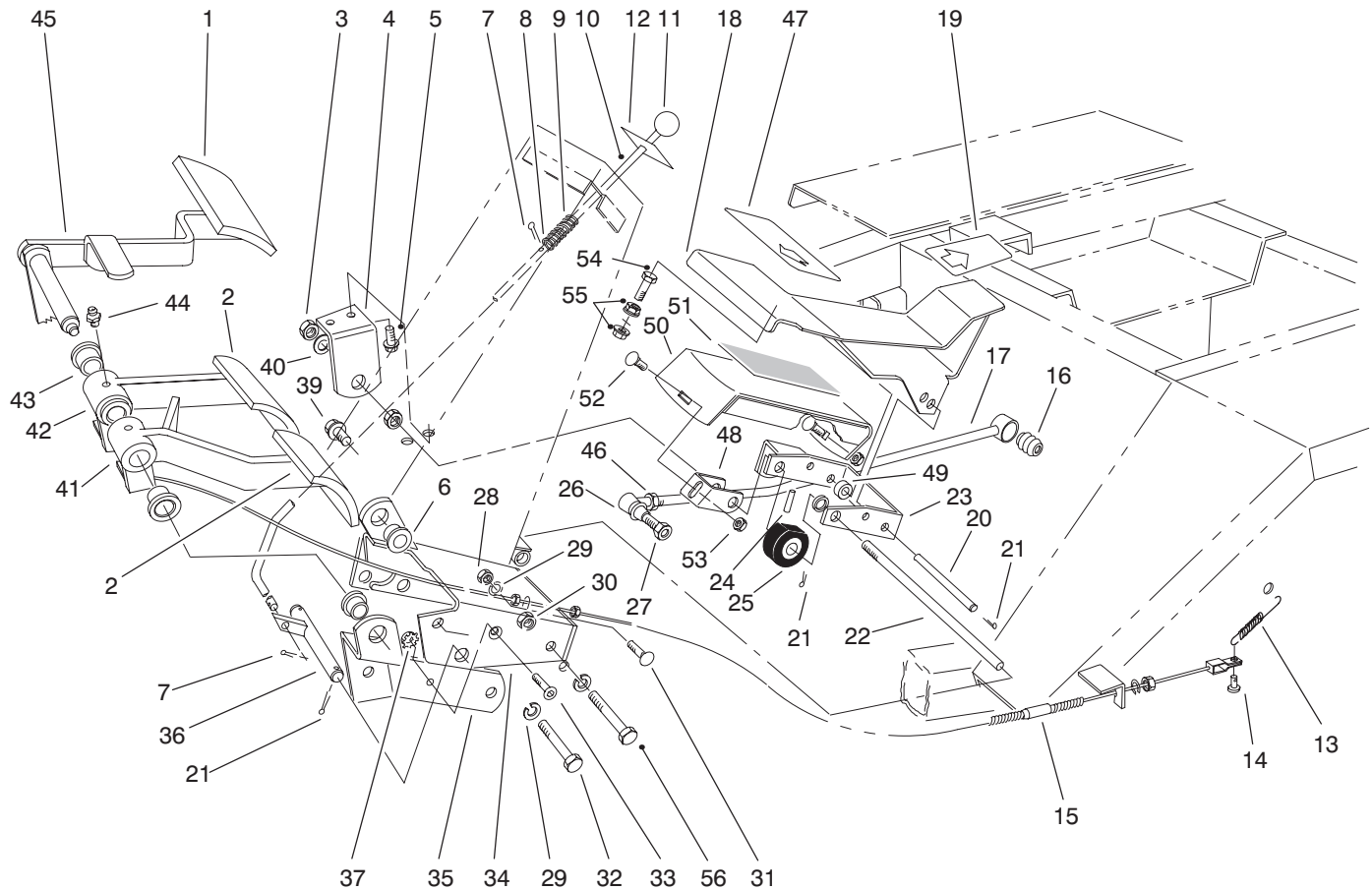

T-0415-8

Brake Pedal Assembly

Ref. No.	Part No.	Description	No. Used	Ref. No.	Part No.	Description	No. Used
1	93-8742	Pad-Brake	1	29	3253-21	Washer-Lock	4
2	93-8743	Pad-Turn	2	30	32153-2	Nut-Lock	2
3	3218-5	Nut-Jam	2	31	3231-21	Bolt-Carriage	2
4	21-2850	Mount-RH Pedal	1	32	323-13	Screw-HH	1
5	11-0590	Screw-TAP	2	33	3274-47	Screw-HSFH	1
6	256-156	Bushing	5	34	27-7590	Mount-Brake	1
7	3272-5	Pin-Cotter	3	35	27-9270	Mount-Brake Pivot Shaft	1
8	3256-22	Washer-Flat	1	36	27-7640	Shaft-Brake Latch	1
9	95-1821	Spring-Compression	1	37	32149-2	Nut	1
10	82-8670	Rod-Brake Latch	1	39	3234-11	Screw-HH	3
11	233-17	Knob	1	40	3256-26	Washer-Flat	1
12	82-8930	Decal-Parking Brake	1	41	27-7490	Pedal-LH Brake (Incl. Ref. #43)	1
13	3-7243	Spring-Extension	2	42	27-7510	Pedal-RH Brake (Incl. Ref. #43)	1
14	283-58	Pin-Clevis	2	43	256-10	Bushing	4
15	21-3380	Cable-LH Brake	1	44	302-5	Fitting-Grease	2
*	21-3370	Cable-RH Brake	1	45	27-8550	Pedal-Parking Brake	1
16	23-2270	Bushing-Rubber	1	46	3220-5	Nut-Jam	1
17	23-2240	Rod-Pump Control	1	47	94-3307	Pad-Front Pedal	1
18	94-3304	Pedal-Traction	1	48	88-1680	Bracket-Footrest	1
19	94-3308	Pad-Rear Pedal	1	49	88-0470	Tube-Pedal Spacer	1
20	88-1640	Pin-Traction Pedal	1	50	88-1710	Footrest	1
21	3272-6	Pin-Cotter	6	51	88-1720	Pad-Footrest	1
22	88-1650	Shaft-Traction Pedal	1	52	3230-1	Bolt-Carriage	2
23	88-1670	Bracket-Pivot (Inc. Ref. #6)	1	53	32128-25	Nut-Flange Lock	2
24	32121-16	Pin-Roll	1	54	323-42	Screw-HH	1
25	28-5220	Wheel-Friction	1	55	32128-43	Nut-HF	2
26	21-0141	Asm-Socket RH	1	56	323-14	Screw-HH	1
27	3220-3	Nut-Jam	1				
28	3217-7	Nut-Hex	2				

*Not Illustrated

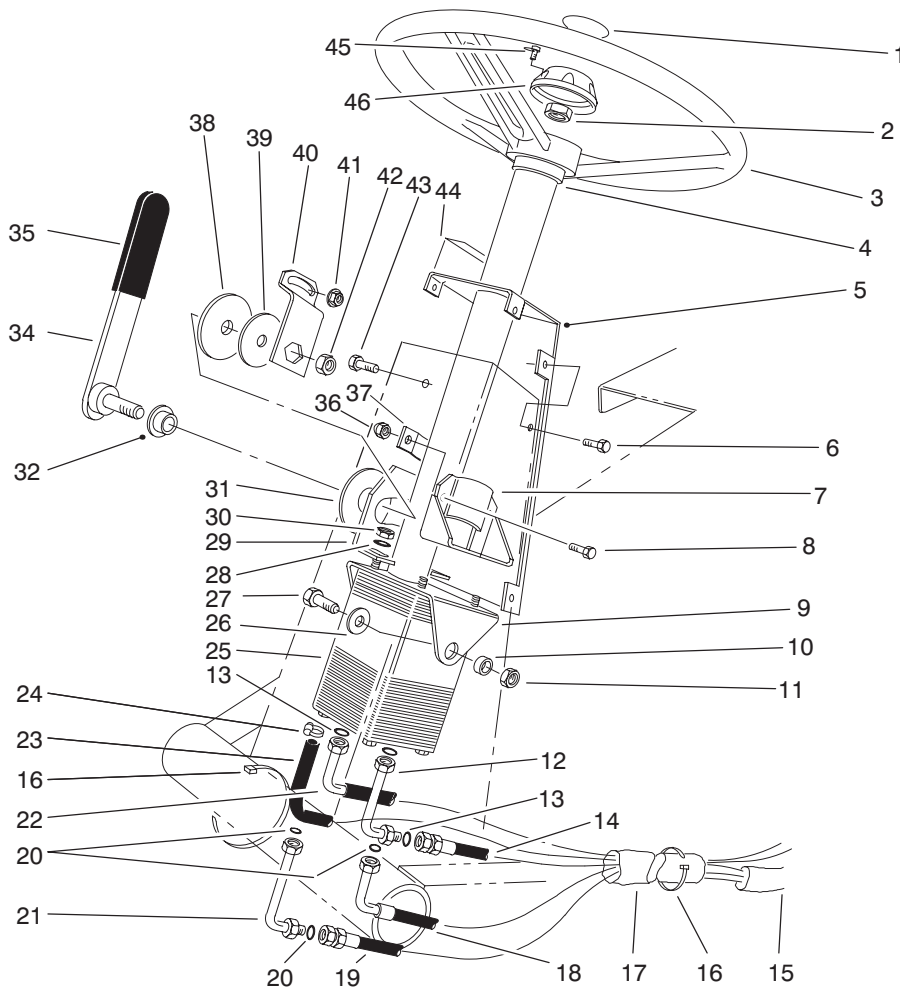

T-1187-3

Power Steering Assembly

Ref. No.	Part No.	Description	No. Used
1	68-5370	Decal-Toro	1
2	66-9760	Nut-Hex.	1
3	75-0560	Asm-Steering Wheel (Incl. Ref. #45 & 46)	1
4	21-9260	Cover-Dust	1
5	82-8660	Cover-Tower	1
6	32144-10	Screw-HWHTF	6
7	67-8690	Support-Column	1
8	3234-17	Screw-HH	2
9	77-3120	Bracket-Mount, Column	1
10	80-2960	Spacer-Tower	2
11	32153-2	Nut-Hex.	2
12	82-8760	Elbow	1
13	237-30	O-Ring	3
14	63-8970	Hose-Trans. to Steering	1
15	70-1390	Sleeve-Protective	1
16	3290-379	Tie-Cable	A/R
17	70-1380	Sleeve-Protective	1
18	68-9730	Hose-Steering to Cylinder	1
19	68-9720	Hose-Cylinder to Steering	1
20	237-22	O-Ring	3
21	82-8770	Elbow	1
22	63-8980	Hose-Aux. to Valve	1

Ref. No.	Part No.	Description	No. Used
23	63-8990	Hose	1
24	2412-36	Clamp	2
25	92-7308	Valve-Steering, Power	1
26	3256-46	Washer-Flat	2
27	323-6	Screw-HH	2
28	3256-3	Washer-Flat	4
29	80-2940	Plate-Pivot	1
30	3296-20	Nut-Lock	4
31	31-0390	Disc-Friction	1
32	80-2980	Boss-Pin	1
34	93-1353	Lever-Steering, Tilt	1
35	21-1880	Grip-Handle	1
36	3296-29	Nut-Lock	2
37	82-8650	Clamp-Half	1
38	82-9010	Disc-Friction	1
39	80-2930	Washer	1
40	80-2880	Bracket-Steering, Tilt	1
41	32128-20	Nut-Flange	1
42	3218-7	Nut-Jam	1
43	322-4	Screw-HH	1
44	82-8940	Decal-Steering, Tilt	1
45	32144-21	Screw	1
46	68-5140	Cap-Wheel, Steering	1

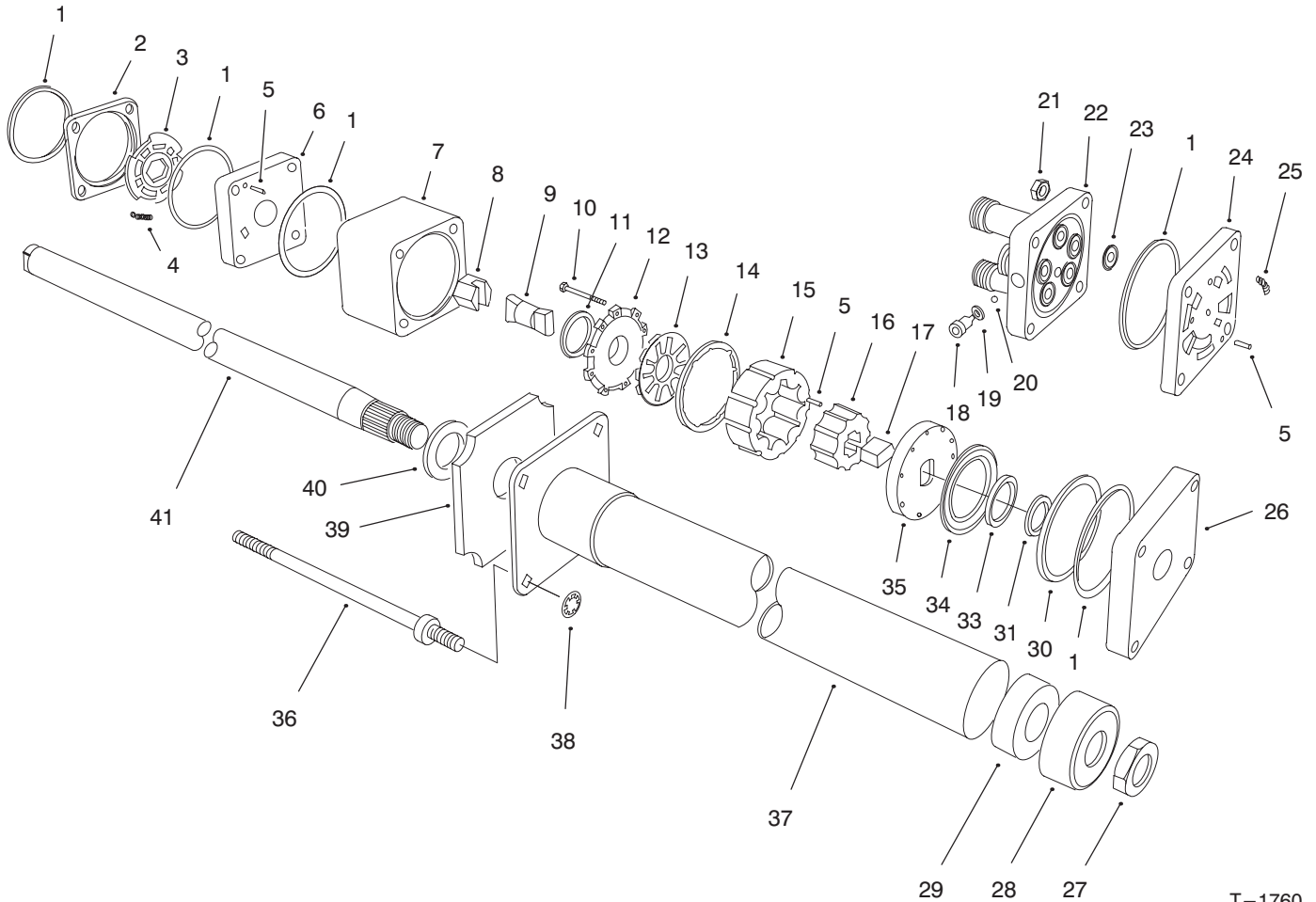

T-1760

Power Steering & Valve Assembly NO.92-7308

Ref. No.	Part No.	Description	No. Used
1		Ring-Seal	5
2		Ring-Valve	1
3		Plate-Valve	1
4		Spring	3
5		Pin-Alignment	9
6		Manifold-Isolation	1
7		Ring-Metering	1
8		Asm-Hex Drive	1
9		Link-Drive	1
10		Screw-HSH	11
11		Seal-Commutator	1
12		Cover-Commutator	1
13		Commutator	1
14		Ring-Commutator	1
15		Stator	1
16		Rotor	1
17		Spacer-Drive Link	1
18		Plug	1
19		O-Ring	1
20		Ball	1
21		Nut-Hex	4
22		Cover-Port	1
23		O-Ring	5
24		Manifold-Port	1
25		Spring	3

Ref. No.	Part No.	Description	No. Used
26		Plate-Upper Cover	1
27	3220-6	Nut	1
28	92-7315	Seal	1
29		Bearing	1
30		Spacer-Thrust Bearing	1
31		Spacer-Seal	1
33		Seal-Face	1
34		Bearing-Thrust	1
35		Plate-Drive	1
36	92-7310	Bolt-Special	4
37		Upper Cover & Jacket	1
38	92-7316	Nut-Push On	4
39	92-7317	Foam	1
40		Washer-Retaining	1
41		Shaft-Input	1
*	66-9970	Kit-Spring (Incl. Ref. #4 & 25)	1
*	66-9980	Kit-Seal (Incl. Ref. #1, 11, 19, 23, 31 & 33)	1
*	66-9990	Kit-Needle Roller (Incl. Ref. #5)	1
*	92-7314	Asm-Column (Incl. Ref. #27-29 & 37-41)	1

*Not Illustrated

Hydraulic Schematic

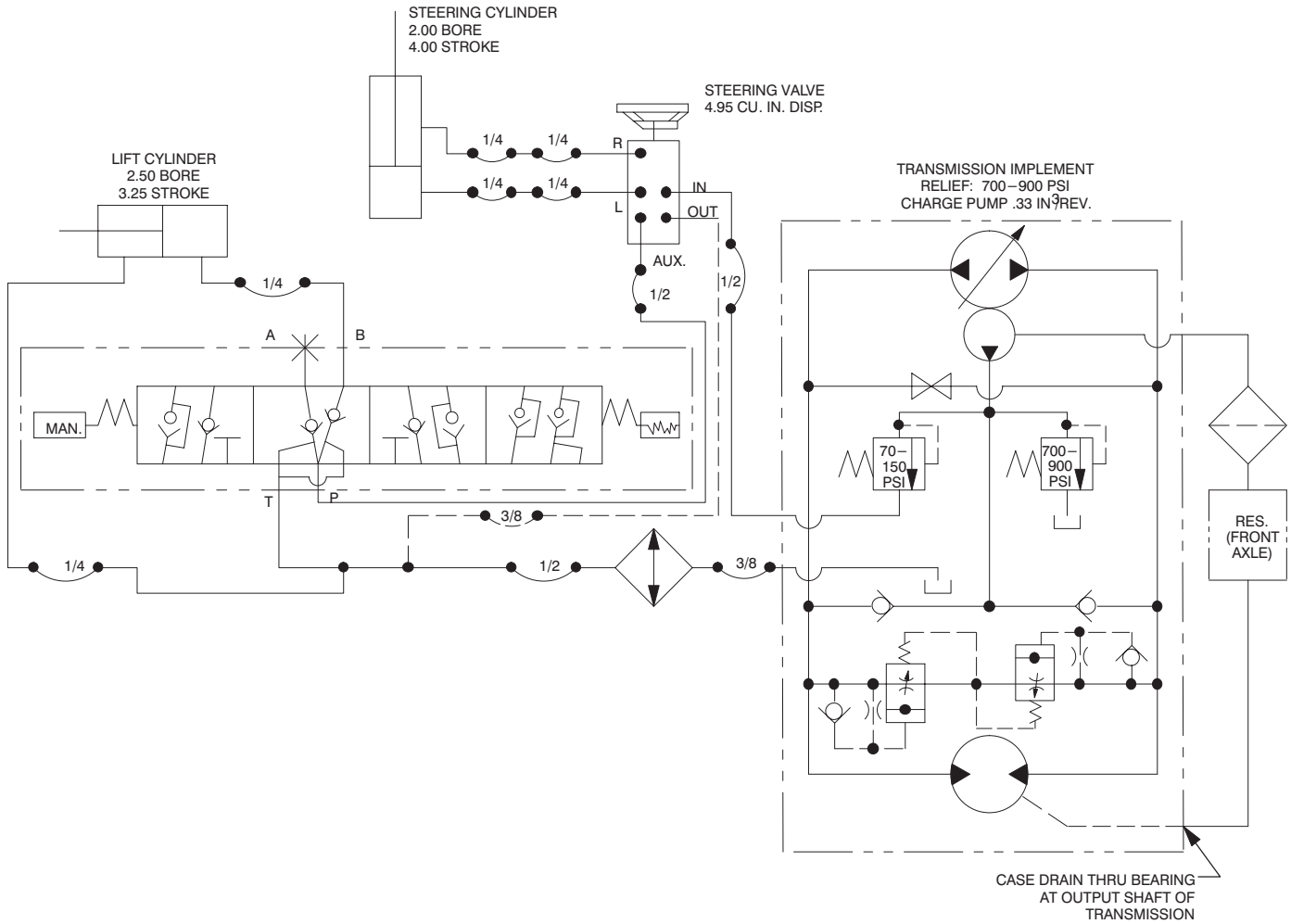

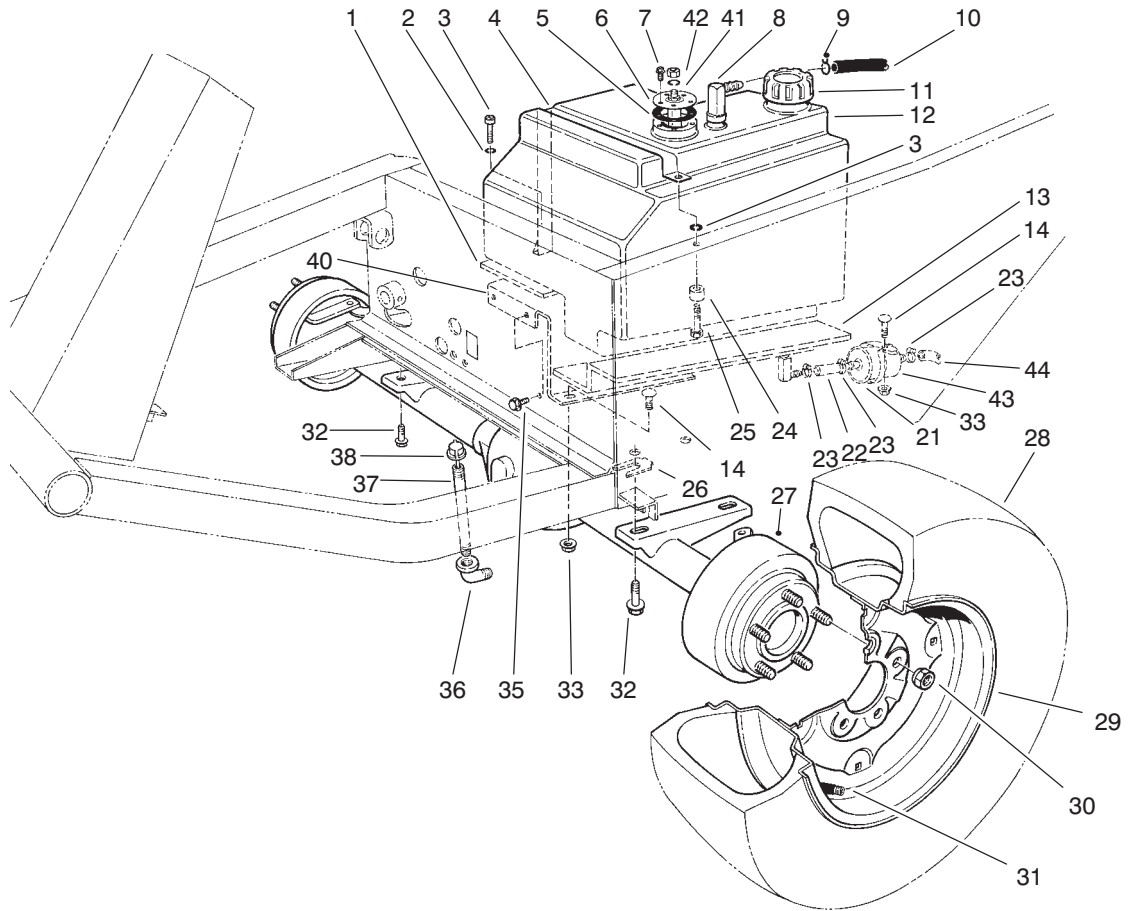

T-0218-1

Front Axle & Fuel Tank Assembly

Ref. No.	Part No.	Description	No. Used
1	21-3600	Foam-Support Tank	1
2	3253-3	Washer-Lock	2
3	32104-96	Screw-HH	1
4	37-9550	Strap-Tank Fuel	1
5	62-7650	Gasket-Tank Fuel	1
6	62-6840	Sender-Fuel Level	1
7	32144-53	Screw-HWHTF	5
8	353-536	Fitting-Tank, Fuel	2
9	2412-6	Clamp	1
10	63-7630	Hose-Vent Fuel	1
11	55-3574	Cap-Tank Fuel	1
12	43-9110	Tank-Fuel (Incl. Ref. #8)	1
13	21-3610	Foam-Support Tank	1
14	3230-2	Bolt-Carriage	3
21	2412-96	Clamp-R	1
22	92-1662	Hose-Fuel	1
23	2412-108	Clamp	3
24	22-7810	Spacer	1
25	321-6	Screw-HH	1
26	42-6080	Shim-Axle	A/R
27	86-9600	Asm-Front Axle	1
28	231-101	Tire	2
*	231-95	Tire-23" x 10.5" x 12" 4 Ply (Optional) 4 Ply	2
*	69-9880	Tire-23" x 10.5" x 12" 6 Ply (Optional)	2

Ref. No.	Part No.	Description	No. Used
29	217-117	Rim	2
*	217-116	Rim-23" x 10.5" x 12" (Optional)	2
30	23-7270	Nut-Wheel	10
31	232-31	Stem-Valve	2
*	232-27	Stem-Valve 23 x 10.5 x 12 (Optional)	2
32	32144-67	Screw-Thread Forming	4
33	32128-20	Nut-Flange	3
35	3234-11	Screw-HHF	2
36	2811-9	Elbow-Street	1
37	289-37	Nipple-Pipe	1
38	23-5180	Dipstick	1
40	68-9760	Base-Tank Fuel	1
41	3253-17	Washer-Lock	1
42	3219-14	Nut	1
43	18-1520	Filter-Gas	1
44	92-1661	Hose-Fuel	1
*	62-7020	Asm-Wheel & Tire 4 Ply (23" x 10.5" x 12") (Optional)	2
*	69-9870	Asm-Wheel & Tire 6 Ply (23" x 10.5" x 12") (Optional)	2
*	231-90	Tube-Inner (Optional)	2
*	95-3093	Kit-400 Hour Filter (Incl. Ref. #43)	1

*Not Illustrated

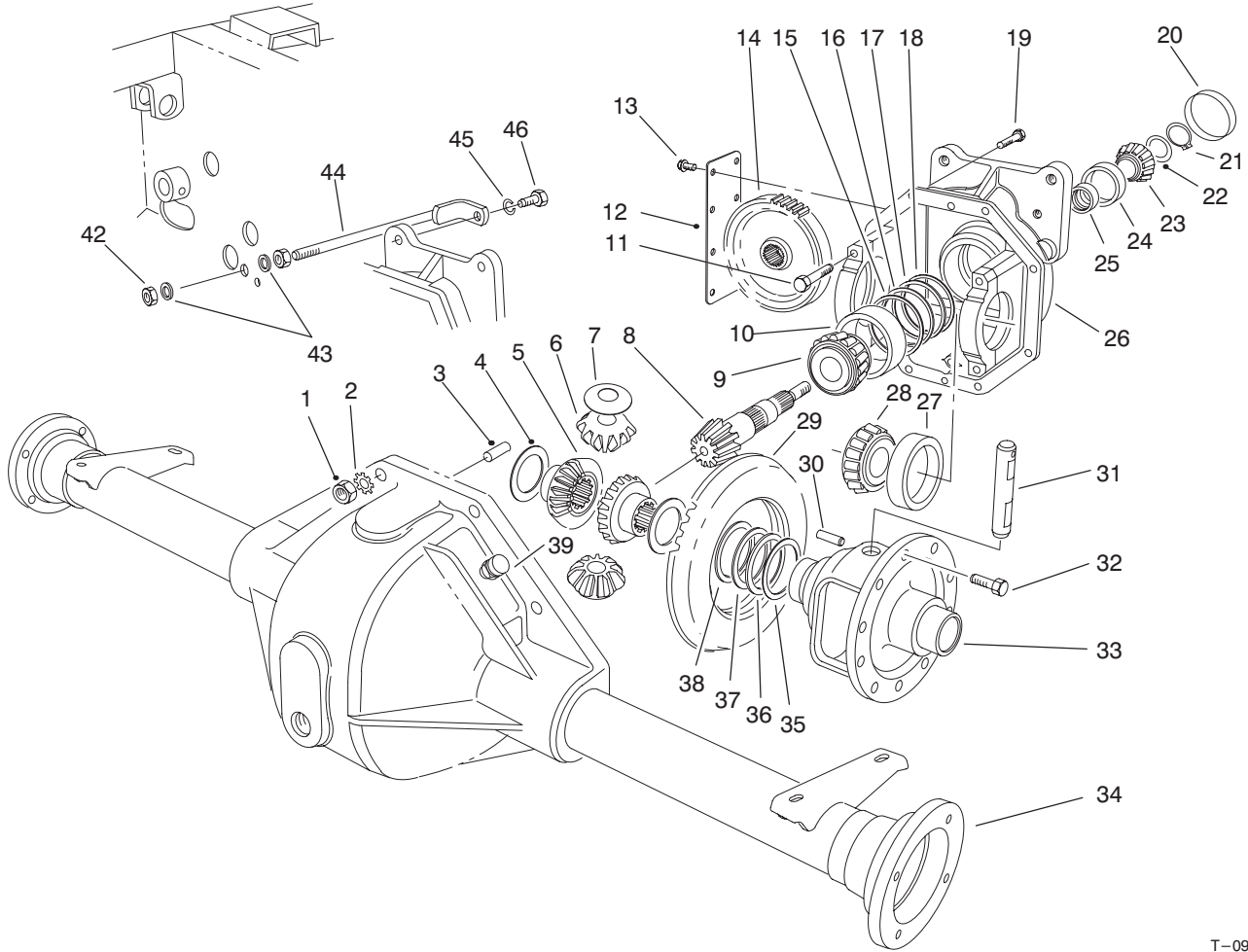

T-0919-2

Front Axle Assembly NO. 86-9600

Ref. No.	Part No.	Description	No. Used
1	3219-2	Nut	8
2	3255-8	Washer-Lock	8
3	21-8270	Dowel Pin	2
4	21-7720	Thrust Washer	2
5	24-8790	Differential Bevel Gear Side	2
6	21-7690	Pinion Gear	2
7	21-7730	Thrust Washer	2
8		Drive Pinion	1
9	43-6760	Roller Bearing Cone	1
10	43-6750	Roller Bearing Cup	1
11	92-1773	Screw-HH	4
12	21-7830	Gear Cover	1
13	32144-112	Thread Forming Screw	8
14	86-7230	Spur-Gear	1
15	43-6710	Adjustment Shim .003	A/R
16	43-6711	Adjustment Shim .005	A/R
17	43-6712	Adjustment Shim .010	A/R
18	43-6713	Adjustment Shim .030	A/R
19	3210-7	Screw-HH	8
20	21-7850	Cap-Plug	1
21	43-6550	Snap Ring	1
22	46-2210	Shim-Front Pinion Bearing (.031)	A/R
*	46-2211	Shim-Front Pinion Bearing (.033)	A/R
*	46-2212	Shim-Front Pinion Bearing (.035)	A/R

Ref. No.	Part No.	Description	No. Used
*22	46-2213	Shim-Front Pinion Bearing (.037)	A/R
*	46-2214	Shim-Front Pinion Bearing (.039)	A/R
*	46-2215	Shim-Front Pinion Bearing (.041)	A/R/
*	46-2216	Shim-Front Pinion Bearing (.043)	A/R
*	46-2220	Shim-Front Pinion Bearing (.045)	A/R
*	46-2221	Shim-Front Pinion Bearing (.047)	A/R
*	46-2222	Shim-Front Pinion Bearing (.049)	A/R
*	46-2223	Shim-Front Pinion Bearing (.051)	A/R
*	46-2224	Shim-Front Pinion Bearing (.053)	A/R
*	46-2225	Shim-Front Pinion Bearing (.055)	A/R
*	46-2226	Shim-Front Pinion Bearing (.057)	A/R
*	46-2410	Shim-Front Pinion Bearing (.062)	A/R
*	46-2411	Shim-Front Pinion Bearing (.064)	A/R

*Not Illustrated

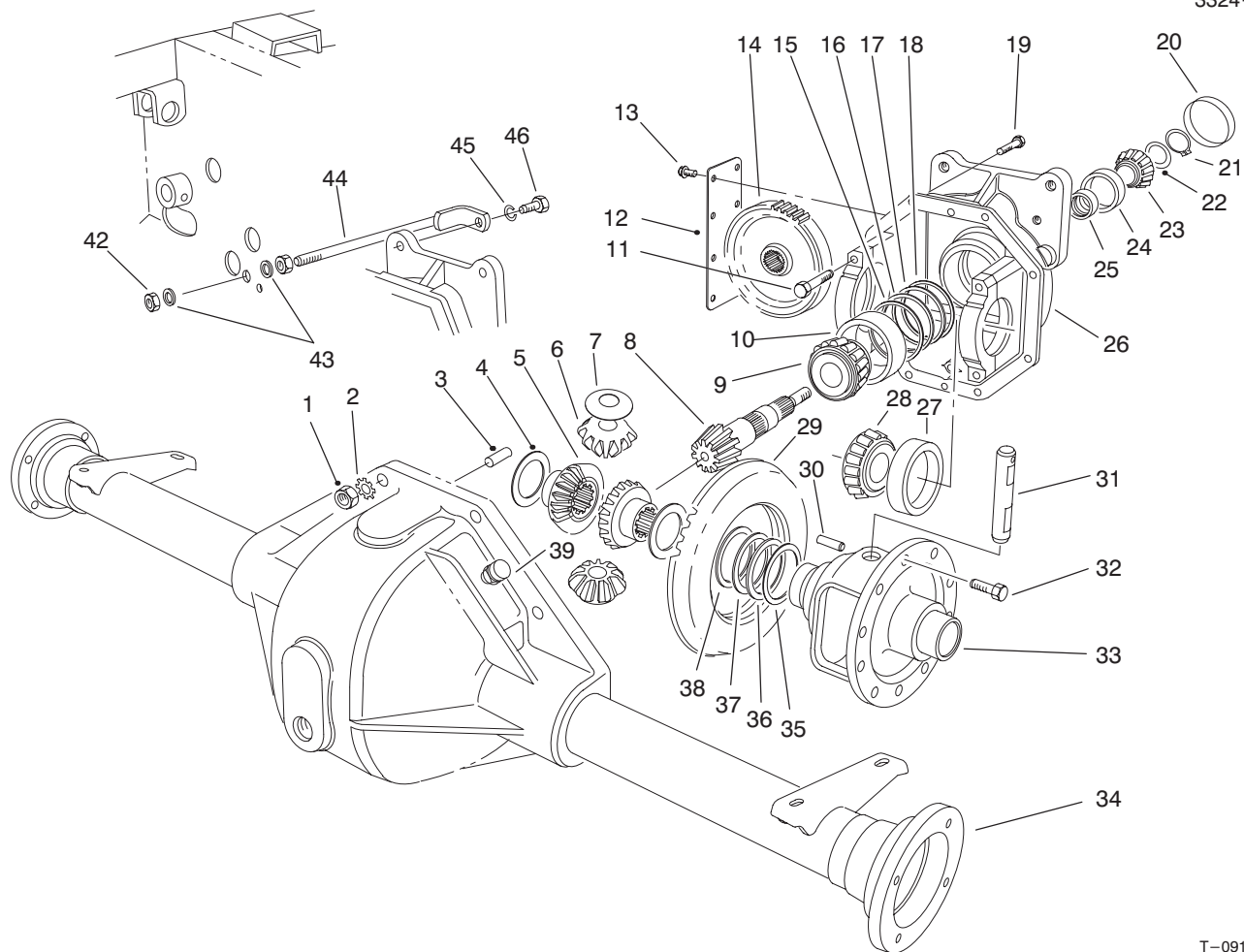

T-0919-2

Front Axle Assembly NO. 86-9600 (Continued)

Ref. No.	Part No.	Description	No. Used	Ref. No.	Part No.	Description	No. Used
*22	46-2412	Shim-Front Pinion Bearing (.066)	A/R	25	21-8020	Spacer-Pinion Bearing	1
*	46-2413	Shim-Front Pinion Bearing (.068)	A/R	26	86-9580	Upper Housing (Incl. Ref. #11)	1
*	46-2414	Shim-Front Pinion Bearing (.070)	A/R	27	254-66	Cup-Tapered Bearing	2
*	46-2415	Shim-Front Pinion Bearing (.072)	A/R	28	254-65	Cone-Tapered Bearing	2
*	46-2416	Shim-Front Pinion Bearing (.074)	A/R	29		Ring Gear	1
*	46-2420	Shim-Front Pinion Bearing (.076)	A/R	30	32121-15	Roll Pin	1
*	46-2421	Shim-Front Pinion Bearing (.078)	A/R	31	21-7700	Pinion Mate Shaft	1
*	46-2422	Shim-Front Pinion Bearing (.080)	A/R	32	21-7770	Drive Gear Screw	5
*	46-2423	Shim-Front Pinion Bearing (.082)	A/R	33	21-7670	Differential Case	1
*	46-2424	Shim-Front Pinion Bearing (.084)	A/R	34	43-6840	Lower Housing	1
*	46-2425	Shim-Front Pinion Bearing (.086)	A/R	35	21-8120	Adjustment Shim .030	A/R
*	46-2426	Shim-Front Pinion Bearing (.088)	A/R	36	21-8110	Adjustment Shim .010	A/R
23	254-91	Bearing Cone	1	37	21-8100	Adjustment Shim .005	A/R
24	254-90	Bearing Cup	1	38	21-8090	Adjustment Shim .003	A/R
				39	72-9420	Vent Tube Assembly	1
				*	92-4903	Asm-Upper Hsg., 2WD (Incl. Ref.#4-33 & 35-38)	1
				*	92-4848	Asm-Gear & Pinion (Incl. Ref. #8 & 29)	1
				42	3217-9	Nut	2
				43	3256-5	Washer-Flat	2
				44	24-9830	Support-Axle	1
				45	3253-21	Washer-Lock	1
				46	323-6	Screw-HH	1

*Not Illustrated

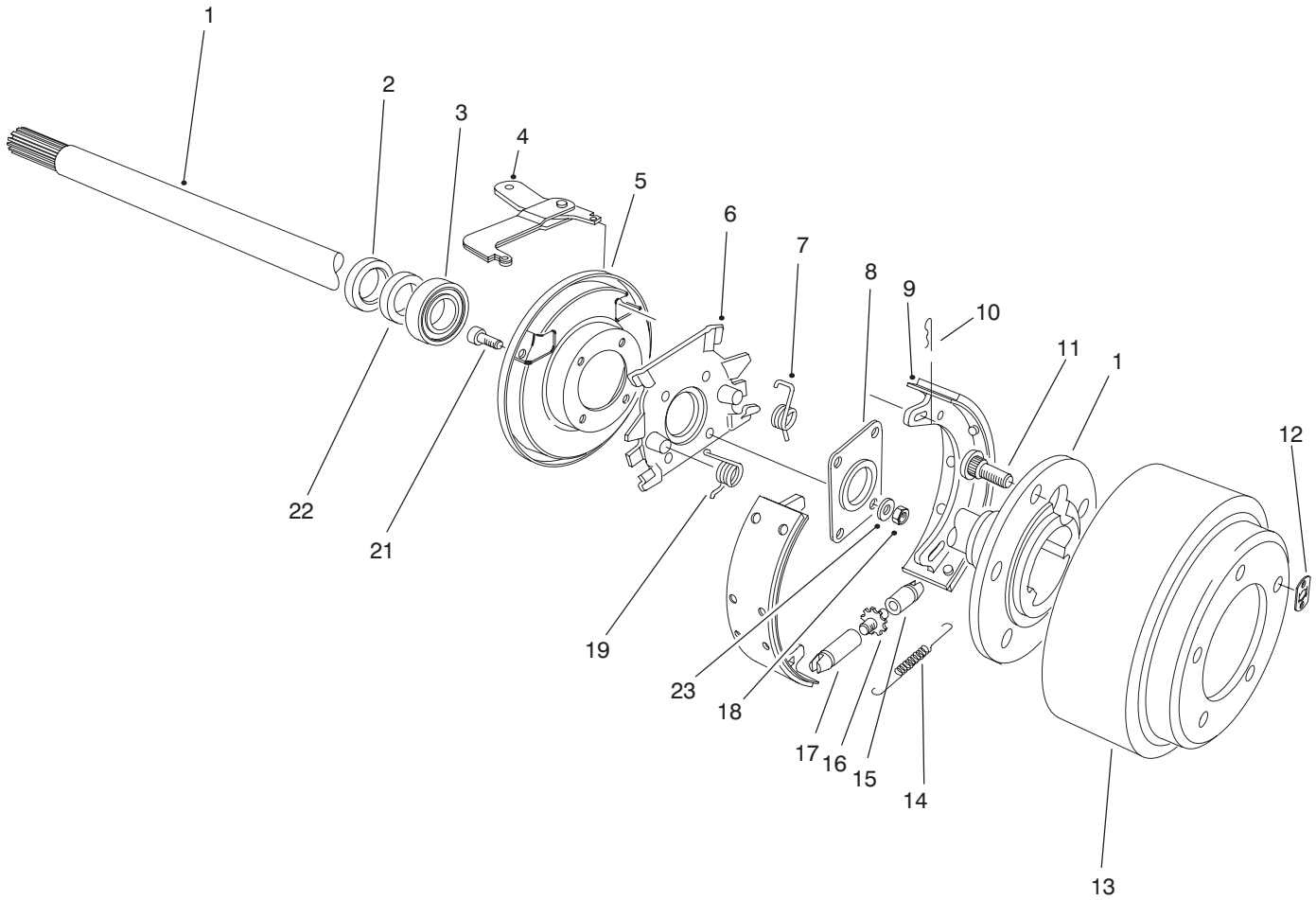

T-0421-6

Brake Assembly

Ref. No.	Part No.	Description	No. Used
1	28-0650	Flanged Axle Shaft	2
2	92-1774	Oil Seal	2
3	21-8180	Bearing	2
4	24-9180	Strut & Lever Parking Brake	2
5	21-9450	Dust Shield	2
6	43-6810	Torque-Spider	2
7	21-9430	Spring-Shoe Return RH	2
8	28-0670	Oil Seal	2
9	84-8600	Asm-Shoe & Lining (Set of 4)	1
10	21-9460	Retainer-Brake Lever	4
11	242-34	Axle Flange Stud	10

Ref. No.	Part No.	Description	No. Used
12	21-8360	Clip-Retaining	2
13	28-0680	Drum-Brake	2
14	21-9440	Spring-Adjusting Screw	2
15	21-9390	Socket-Adjusting Screw	2
16	21-9370	Screw-Adjusting	2
17	21-9380	Nut-Pivot	2
18	94-6935	Nut-Lock	8
19	21-9420	Spring-Shoe Return LH	2
21	94-6934	Screw-Socket Hd.	8
22	24-8840	Ring-Wheel Bearing	2
23	94-6936	Washer	8
*	92-8775	Gasket Kit-Liquid	2

*Not Illustrated

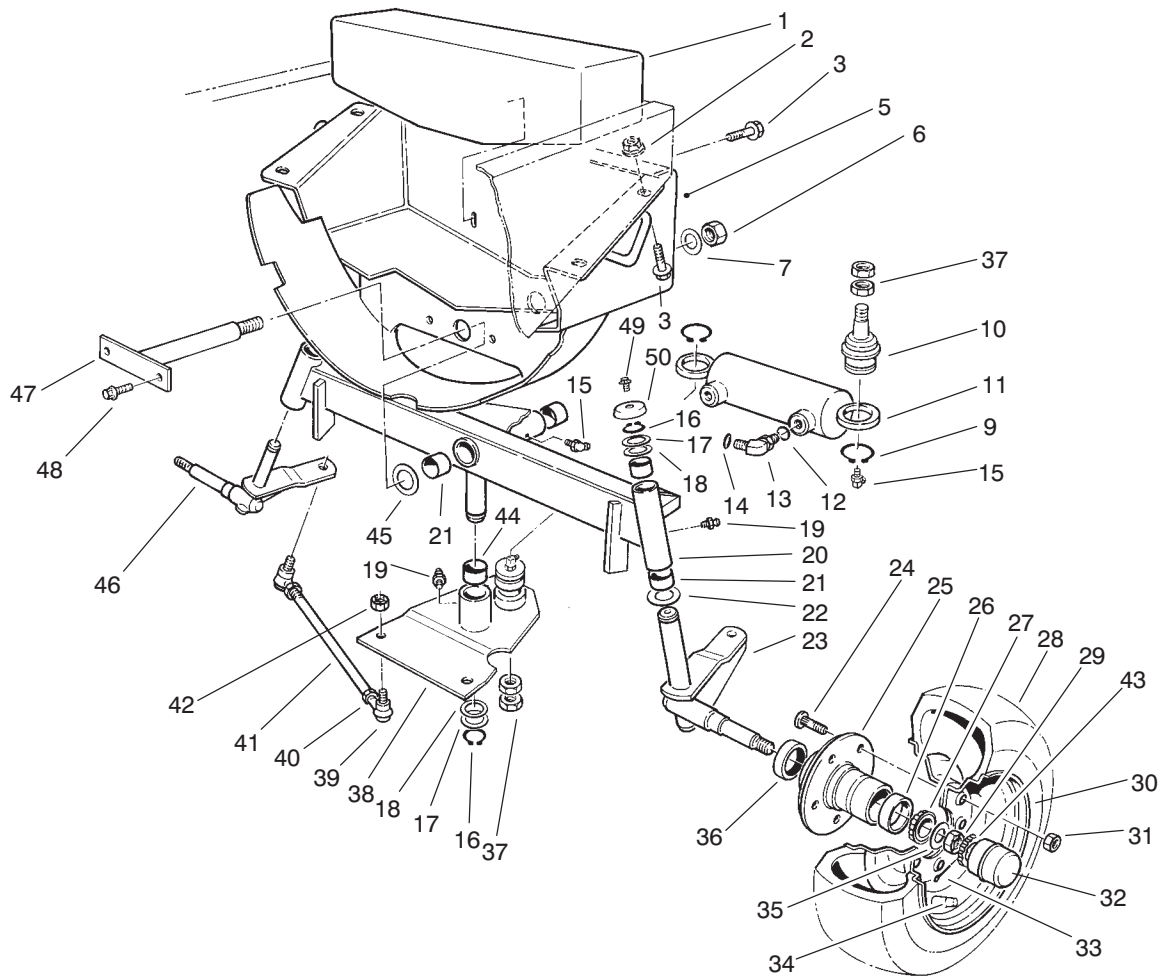

T-1759-1

Rear Wheel & Axle Assembly

Ref. No.	Part No.	Description	No. Used	Ref. No.	Part No.	Description	No. Used
1	98-3869-01	Weight-Axle Rear	1	29	3220-7	Nut-Jam	2
2	32128-23	Nut-Lock, Flange	4	30	217-106	Wheel	2
3	3234-32	Screw-HHF	6	31	242-50	Nut-Wheel	10
5	92-7841	Support-Axle Rear	1	32	241-119	Cap-Dust	2
6	32146-20	Nut-Lock	1	33	3272-13	Pin-Cotter	2
7	71-4540	Washer-Thrust	1	34	232-31	Stem-Valve w/Cap	2
9	32151-104	Ring-Retaining	2	35	93-0309	Washer-Tab	2
10	92-5838	Ball Joint	2	36	253-129	Closure	2
11	92-7828	Cylinder-Hydraulic	1	37	3220-6	Nut-Jam	4
12	237-78	O-Ring	1	38	92-7821	Pivot-Steering (Incl. Ref. #44)	1
13	340-54	Fitting-45°	1	39	21-0140	Asm-Socket RH (Incl. Ref. #42)	2
14	237-22	O-Ring	1	*	21-0150	Asm-Socket LH (Incl. Ref. #42)	2
15	302-11	Fitting	3	40	3220-5	Nut-Jam RH Thread	2
16	32151-36	Ring-Retaining	3	*	3220-12	Nut-Jam LH Thread	2
17	5-1226	Washer	A/R	41	21-2000	Rod-Tie	2
18	10-8110	Washer	3	42	3220-3	Nut-Jam	8
19	302-5	Fitting	3	43	93-0307	Retainer-Nut, Lock	2
20	100-6566	Axle-Rear (Incl. Ref. #21)	1	44	256-242	Bushing	2
21	67-1750	Bushing-Axle	6	45	56-2460	Washer	A/R
22	256-121	Bushing-Thrust	2	46	93-3199	Asm-Spindle RH	1
23	93-3198	Asm-Spindle LH	1	47	92-7843	Pin-Axle Rear	1
24	10-6830	Stud-Drive	10	48	32144-14	Screw-TAP	2
25	21-2820	Hub-Wheel (Incl. Ref. #24 & 26)	2	49	3234-13	Screw	2
26	254-72	Cup-Bearing	4	50	66-2990	Cup-Spindle	2
27	254-94	Cone-Bearing	4				
28	231-105	Tire	2				

*Not Illustrated

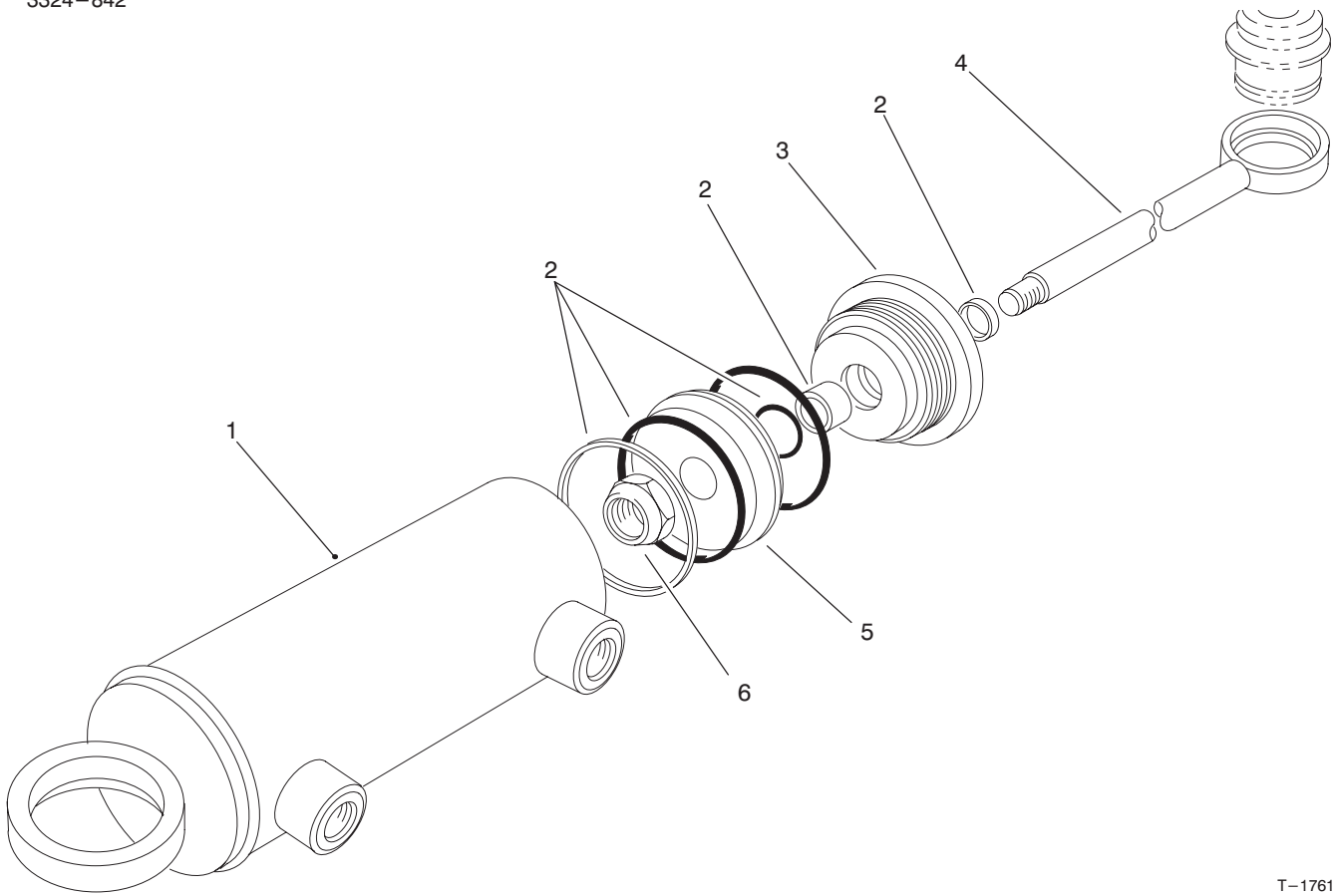

T-1761-2

Hydraulic Steering Cylinder NO. 92-7828

Ref. No.	Part No.	Description	No. Used
1		Asm-Tube	1
2	92-6593	Seal Kit	1
3	92-6588	Gland	1
4		Asm-Piston Rod	1

Ref. No.	Part No.	Description	No. Used
5	66-1940	Piston	1
6	66-1930	Nut-Lock	1
*	92-7828	Cylinder-Hydraulic (Incl. Ref. #1-6)	1

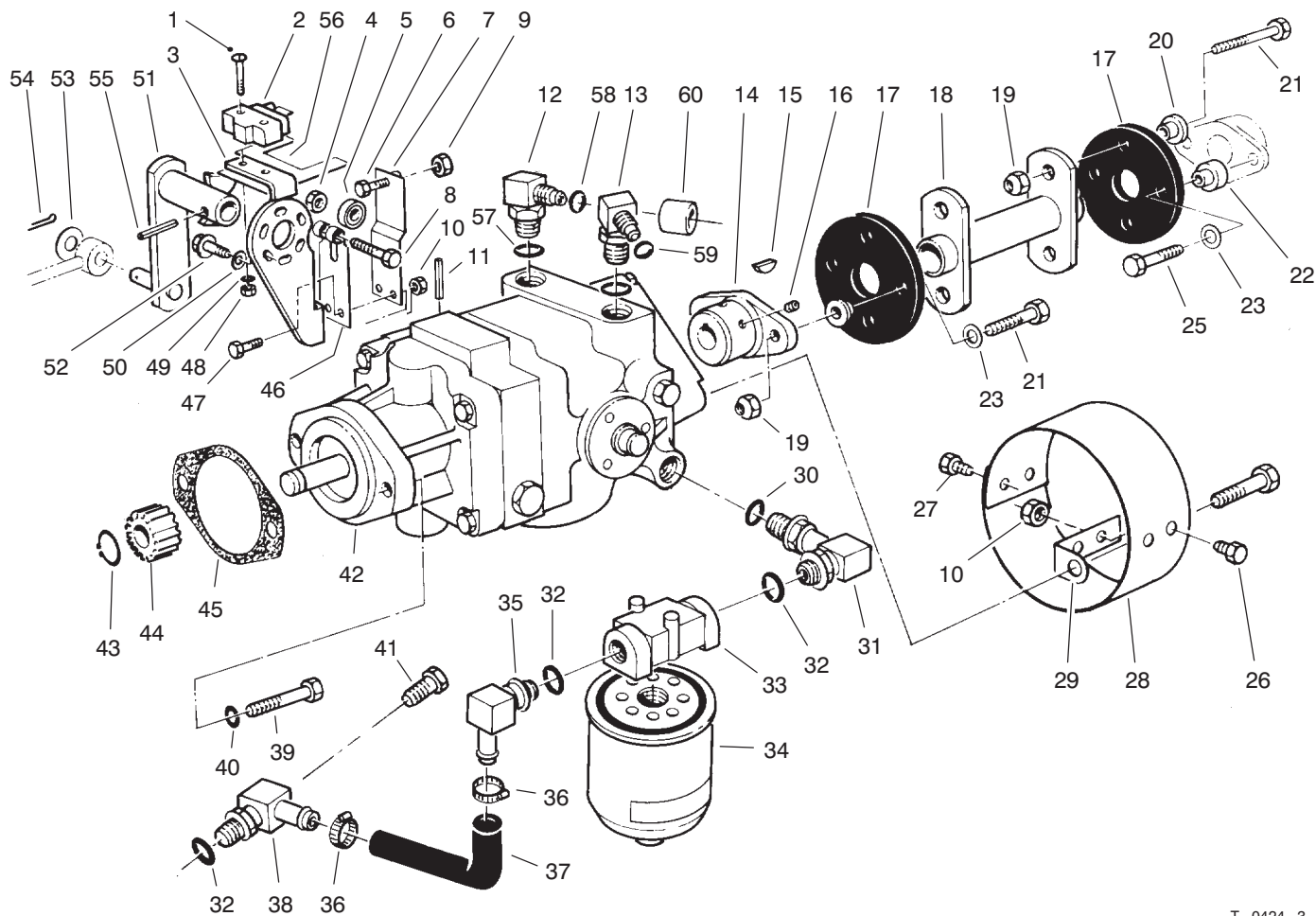

T-0424-3

Hydraulic Transmission Assembly

Ref. No.	Part No.	Description	No. Used	Ref. No.	Part No.	Description	No. Used
1	3249-11	Screw-Round Hd. Mach.	2	28	54-9300	Cover	1
2	29-6163	Micro Switch	1	29	54-9290	Bracket	2
3	29-6120	Pump Plate	1	30	237-80	O-Ring	1
4	3296-29	Nut-Lock	1	31	68-8660	Elbow	1
5	251-259	Ball Bearing	1	32	237-81	O-Ring	3
6	3210-7	Screw-HH	1	33	68-8990	Head-Filter	1
7	29-6170	Extended Leaf Spring	1	34	23-9740	Oil Filter	1
8	322-17	Screw-HH	1	35	353-987	Elbow	1
9	3219-2	Nut-Hex	1	36	2412-34	Clamp-Hose	2
10	3296-42	Nut-Lock	6	37	68-9650	Hose-Axle	1
11	32121-6	Roll Pin	1	38	70-2620	Elbow-90°	1
12	340-77	Elbow	1	39	323-7	Screw-HH	2
13	340-99	Elbow	1	40	3253-21	Washer-Lock	2
14	33-4380	Pump Hub	1	41	353-508	Plug-Drain	1
15	3257-32	Woodruff Key	1	42	92-8947	Transmission-Inline	1
16	3241-5	Square Hd. Set Screw	2	43	32120-72	Ring-Retaining External	1
17	44-2230	Rubber Coupling	2	44	86-7220	Gear-Transmission Output	1
18	46-6390	Drive Coupling	1	45	41-8760	Gasket-Transmission	1
19	32152-1	Nut-Lock	8	46	29-6150	Leaf Spring	1
20	27-6600	Spacer Rubber Coupling	6	47	321-6	Screw-HH	2
21	322-6	Screw-HH	6	48	3217-16	Nut	2
22	27-6590	Spacer Rubber Coupling	2	49	3254-9	Washer-Lock	2
23	3256-3	Washer-Flat	4	50	3255-7	Washer-Lock	3
25	322-8	Screw-HH	2	51	28-9570	Pump Lever	1
26	321-2	Screw-HH	2	52	11-9760	Screw-TAP	3
27	321-4	Screw-HH	2	53	3256-6	Washer-Flat	1

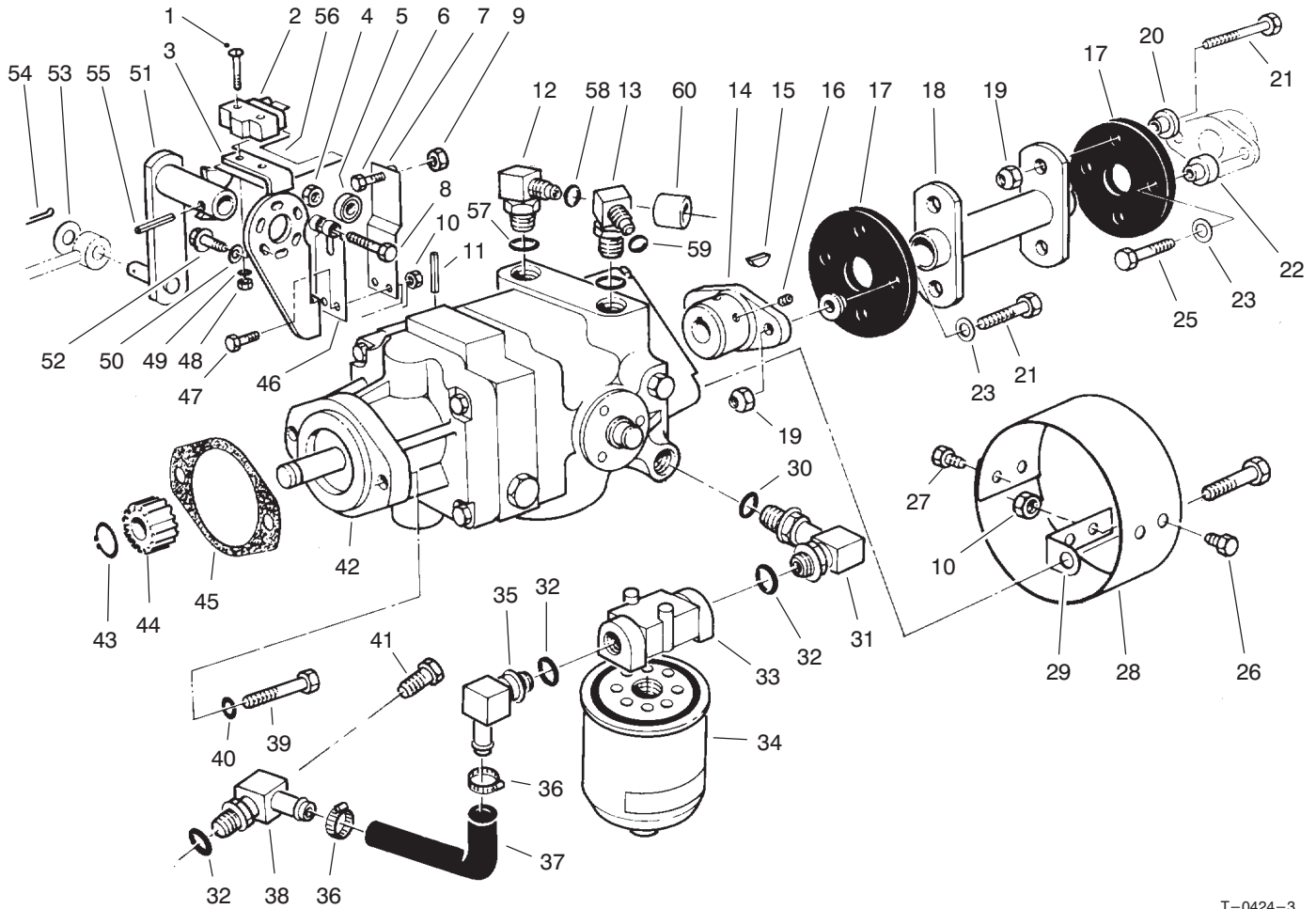

T-0424-3

Hydraulic Transmission Assembly (Continued)

Ref. No.	Part No.	Description	No. Used
54	3272-10	Cotter Pin	1
55	32121-24	Roll Pin	1
56	46-8810	Stop-Leaf Spring	1
57	237-42	O-Ring	2
58	237-22	O-Ring	1

Ref. No.	Part No.	Description	No. Used
59	237-30	O-Ring	1
60	38-3400	Guard-Rubber	1
*	95-3093	Kit-400 Hour Filter (Incl. Ref. #34)	1

* Not Illustrated

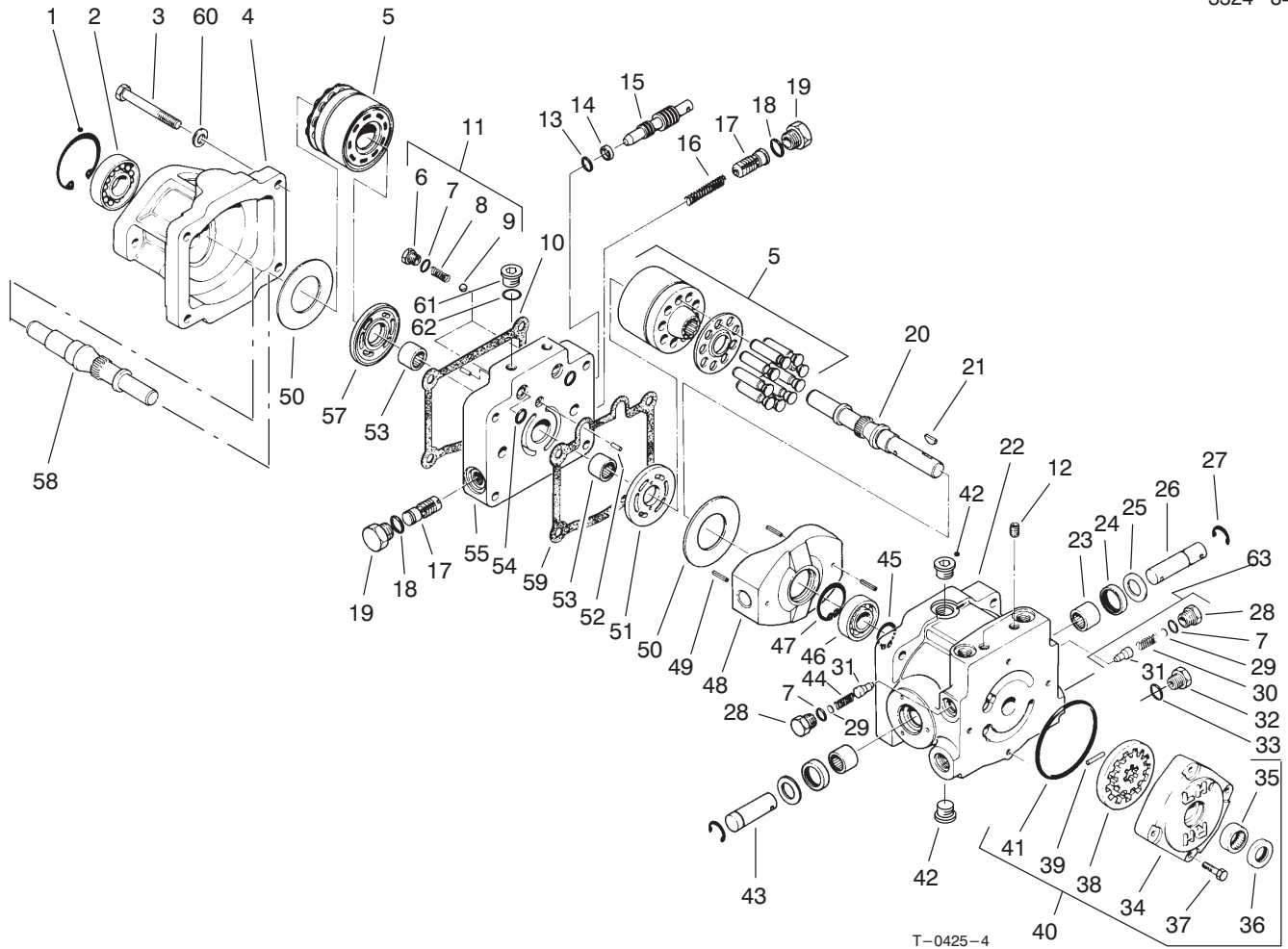

Transmission Assembly No. 92-8947

Ref. No.	Part No.	Description	No. Used
1	32120-8	Retaining Ring	1
2	72-3750	Roller Bearing	1
3	323-56	Screw-HH	4
4	67-9080	Motor Housing	1
5	48-1800	Kit-Cylinder Block	2
6	25-2650	Check Valve Plug	2
7	237-86	O-Ring	4
8	25-2640	Valve Spring	2
9	25-2490	Ball	2
10	67-9100	Gasket	1
12	285-17	Pipe Plug	2
13	237-22	O-Ring	1
14	25-2630	Back Up Ring	1
15	88-8220	By Pass Valve	1
16	25-2610	Accel. Valve Spring	1
17	25-2410	Asm-Accel. Valve	2
18	76-1900	O-Ring	2
19	353-550	Plug-Hex. Hd.	2
20	67-8020	Pump Shaft	1
21	3257-32	Woodruff Key	1
22	54-7890	Pump Housing (Incl. Ref. #12 & 23-25)	1
23	252-82	Needle Bearing	2
24	25-3210	Lip Seal	2
25	25-2510	Washer-Flat	2
26	25-2580	Trunnion Shaft	1

Ref. No.	Part No.	Description	No. Used
27	32151-46	Retaining Ring	2
28	25-2460	Plug-HH	2
29	25-2470	Shim Pack	2
30	25-2570	Valve Spring	1
31	83-7260	Relief Valve Cone	2
32	353-551	Plug-HH	1
33	237-80	O-Ring	1
34	25-2550	Charge Pump Housing	1
35	67-8050	Needle Bearing	1
36	93-4133	Lip Seal	1
37	322-4	Screw-HH	4
38	25-2680	Asm-Gerotor	1
39	25-2530	Headless Straight Pin	1
40	25-3190	Charge Pump (Incl. Ref. #34-39 & 41)	1
41	237-95	O-Ring	1
42	67-9090	Plug	2
43	25-2500	Trunnion Shaft	1
44	25-2480	Valve Spring	1
45	32120-15	Retaining Ring	1
46	251-8	Ball Bearing	1
47	32120-11	Retaining Ring	1
48	25-2450	Variable Swashplate	1
49	32121-91	Coil Spring Pin	3
50	25-2380	Thrust Plate	2
51	25-2440	Pump Valve Plate	1

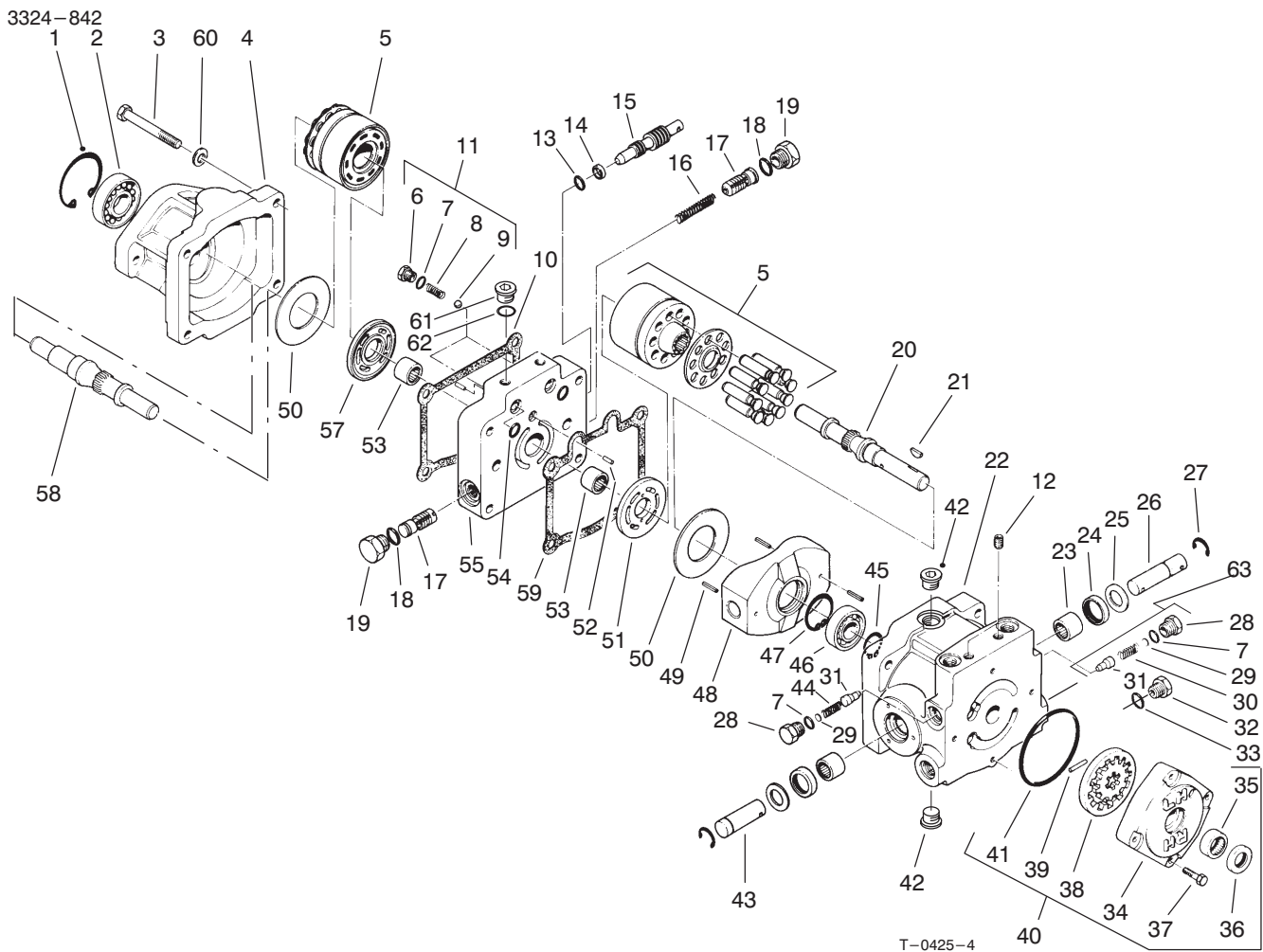

Transmission Assembly No. 92-8947 (Continued)

Ref. No.	Part No.	Description	No. Used
52	25-2430	Dowel Pin	2
53	46-8400	Needle Bearing	2
54	93-4132	O-Ring	2
55	92-8918	Center Section	1
57	25-2390	Motor Valve Plate	1
58	46-8410	Motor Shaft	1
59	25-2400	Gasket	1

Ref. No.	Part No.	Description	No. Used
60	93-0312	Washer	4
61	92-8776	Plug (Incl. Ref. #62)	4
62	92-8777	O-Ring	2
63	49-8520	Kit-Relief, Implement (Incl. Ref. #7 & 28-31)	1

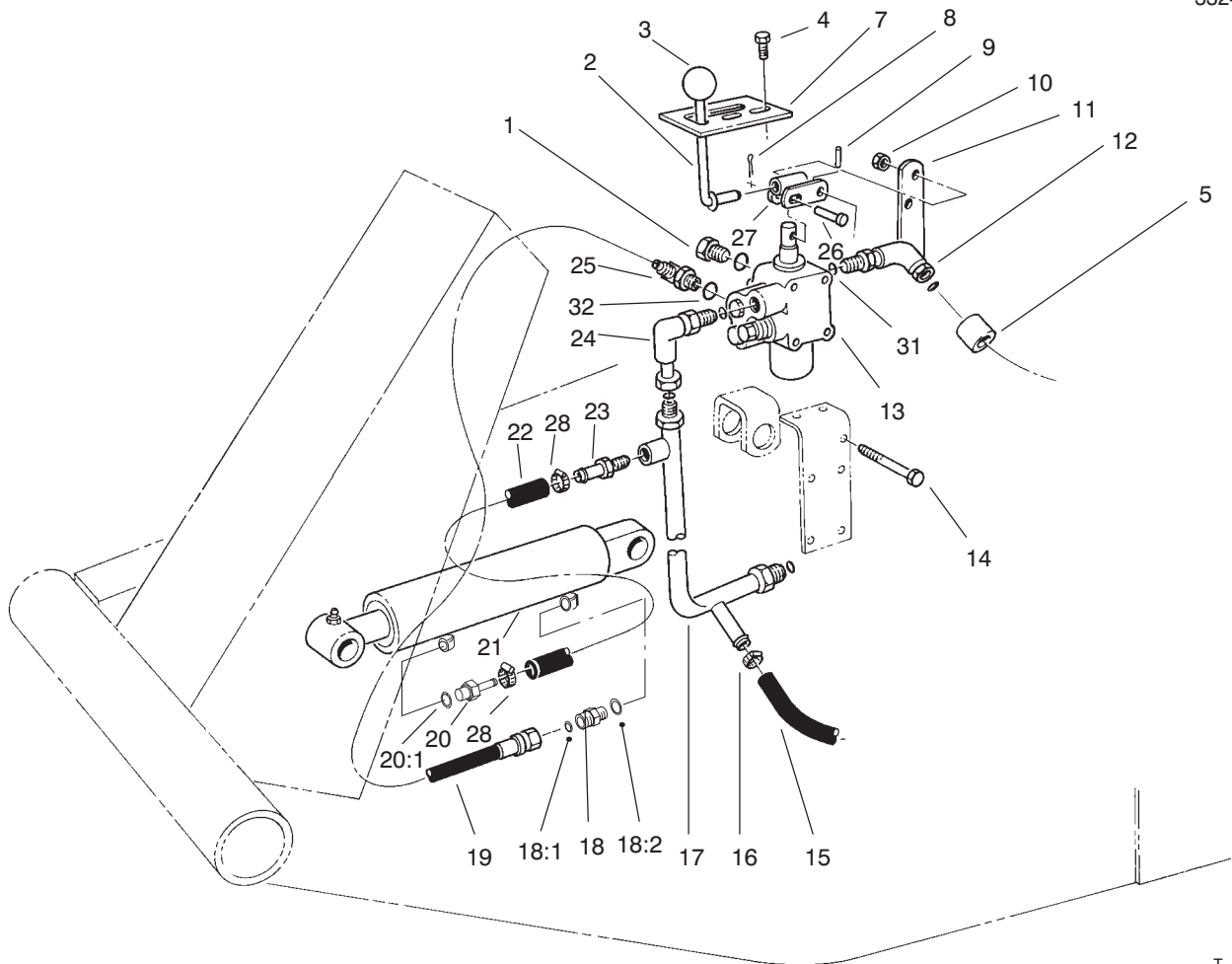

T-0426-5

Valve & Cylinder Assembly

Ref. No.	Part No.	Description	No. Used	Ref. No.	Part No.	Description	No. Used
1	353-512	Plug	1	18:1	237-22	O-Ring	1
2	21-8620	Lever Valve	1	18:2	237-42	O-Ring	1
3	233-21	Knob	1	19	92-7833	Hose-Valve to Cylinder	1
4	32144-10	Screw-TAP	2	20	95-8849	Fitting-90° Barb	1
5	38-3400	Guard-Rubber	1	20:1	237-78	O-Ring	1
7	21-8640	Latch Valve Lever	1	21	100-6586	Cylinder-Hydraulic	1
8	3272-6	Cotter Pin	1	*	100-6591	Cylinder-Hydraulic (Optional)	1
9	32121-73	Pin Slotted Spring	1	22	92-7834	Hose	1
10	3296-42	Nut-Lock	5	23	304-73	Fitting-Straight Barb	1
11	21-9010	Pivot Mount-Valve Lever	1	24	340-110	Elbow-90°	1
12	340-99	Fitting-90° Elbow	1	25	340-97	Fitting-90°	1
13	43-1710	Asm-Valve	1	26	283-17	Pin	1
14	321-23	Screw-HH	5	27	21-8590	Link-Valve Lever	1
15	63-8990	Hose	1	28	2412-108	Clamp Hose	2
16	2412-36	Clamp-Hose	1	31	237-42	O-Ring	2
17	63-9260	Manifold-Valve	1	32	237-78	O-Ring	2
18	340-2	Elbow 90°	1				

*Not Illustrated

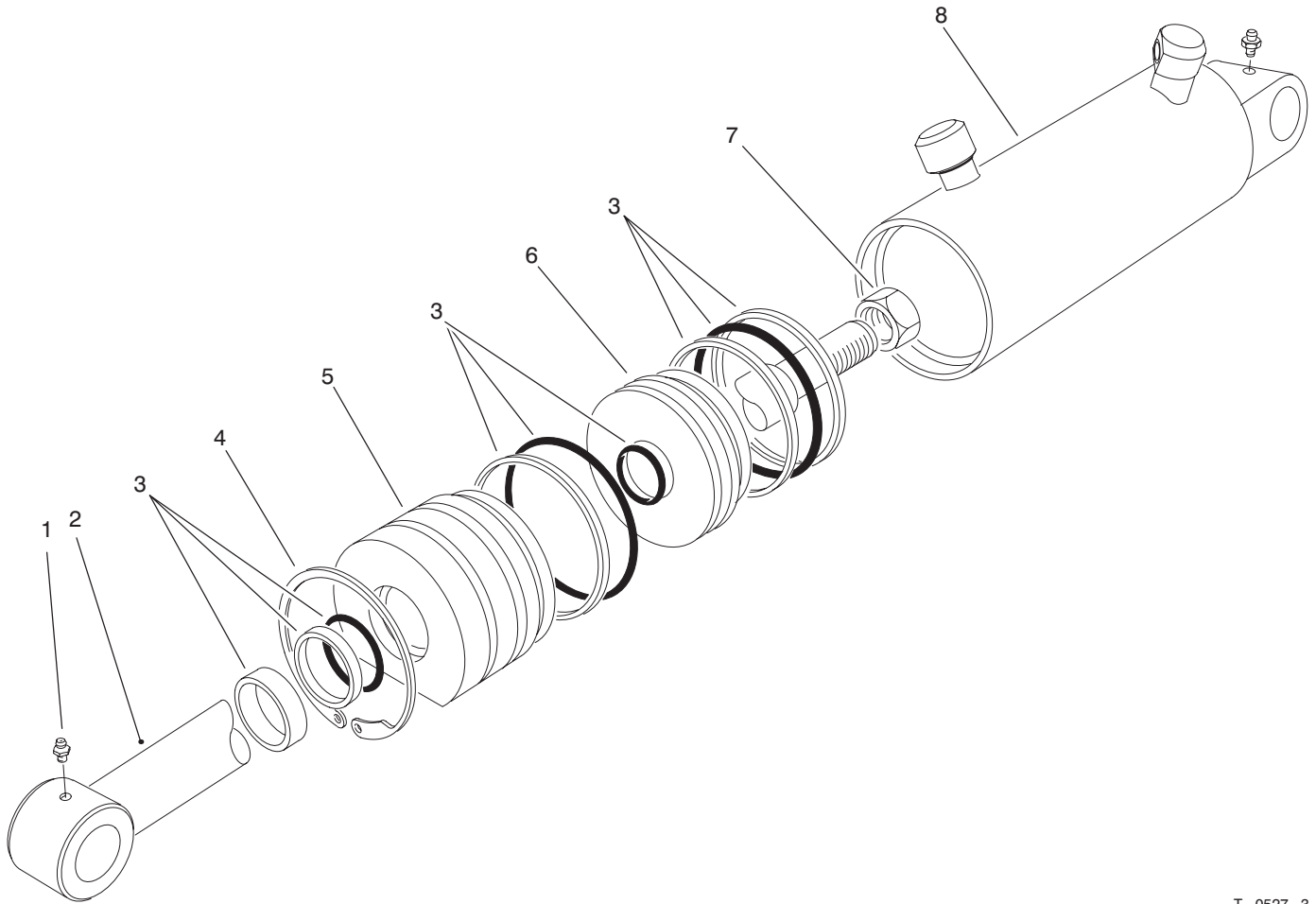

T-0527-3

Hydraulic Lift Cylinder Assembly No. 100-6586 (2-1/2" Bore)

Ref. No.	Part No.	Description	No. Used
1	302-55	Fitting-Grease	2
2	61-4980	Shaft-w/Clevis	1
3	61-4960	Repair Kit	1
4	61-4990	Ring-Retaining	1

Ref. No.	Part No.	Description	No. Used
5	60-9780	Head	1
6	60-9770	Piston	1
7	60-9760	Nut	1
*8		Barrel	1

*Not available separately.

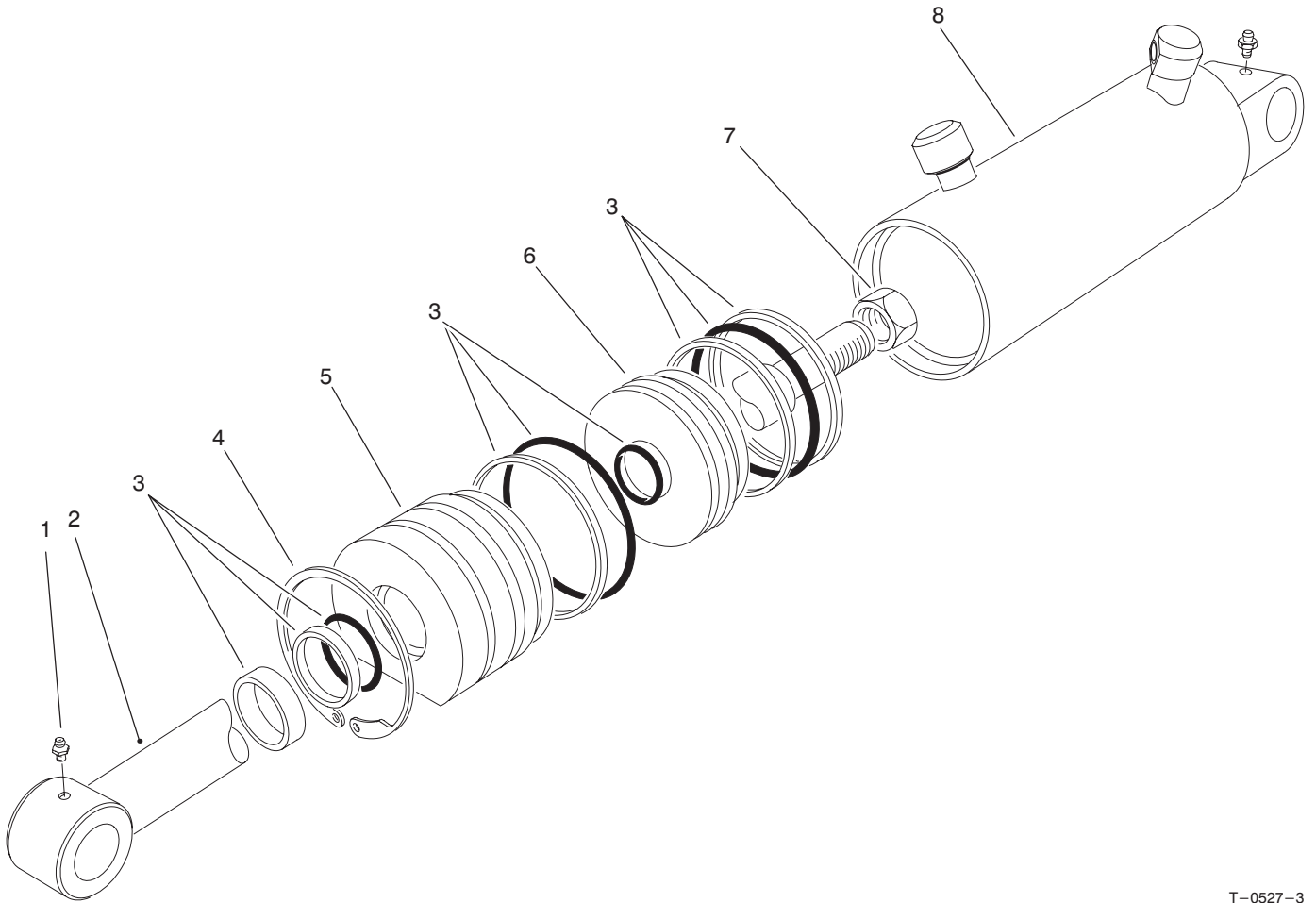

T-0527-3

Hydraulic Lift Cylinder Assembly No. 100-6591 (3" Bore)

Ref. No.	Part No.	Description	No. Used
1	302-55	Grease Fitting	2
2	67-5480	Shaft	1
3	67-5500	Repair Kit	1
4	67-5470	Ring-Retaining	1

Ref. No.	Part No.	Description	No. Used
5	67-5460	Head	1
6	67-5450	Piston	1
7	60-9760	Nut-Hex	1
*8		Barrel	1

*Not available separately.

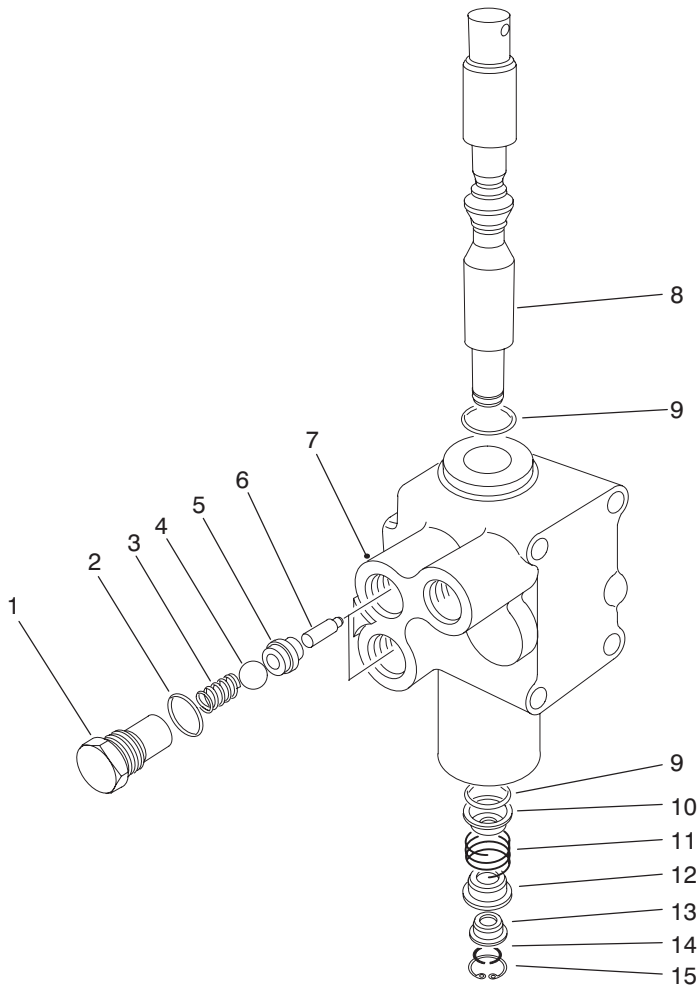

T-0428-1

Control Valve Assembly No. 43-1710

Ref. No.	Part No.	Description	No. Used
1	22-8330	Plug	2
2	237-42	O-Ring	2
3	22-8340	Spring	2
4	22-8350	Ball	2
5	22-8370	Seat-Check Valve	2
6	22-8360	Pin-Cam	2
7	43-1730	Body	1
8	22-8420	Spool	1

Ref. No.	Part No.	Description	No. Used
9	22-8500	O-Ring	2
10	22-8380	Spring Retainer	1
11	22-8410	Spring	1
12	22-8390	Spring Retainer	1
13	22-8400	Spacer Float	1
14	22-8480	Spring Ring Spool	1
15	22-8490	Snap Ring	1

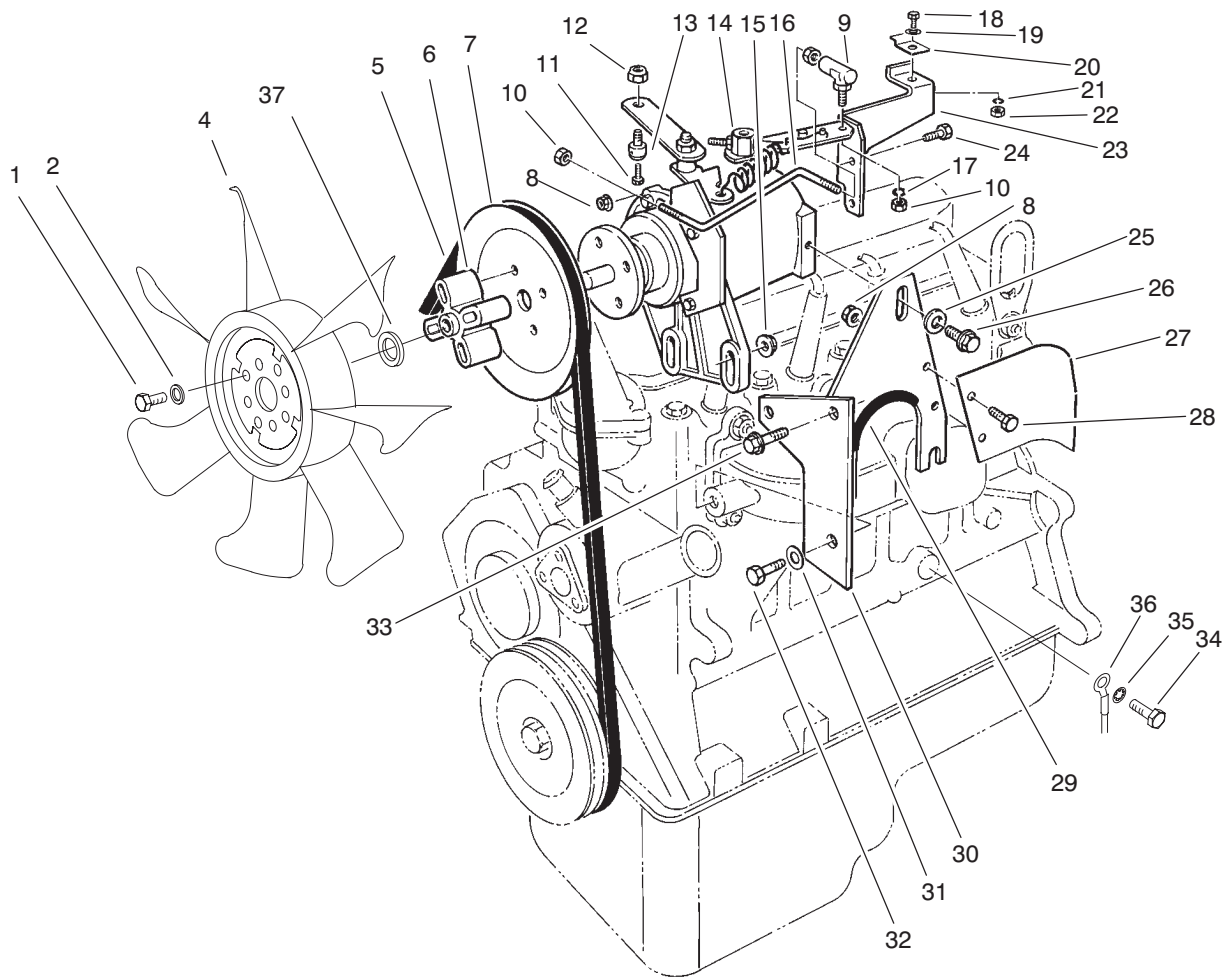

T-0921

Engine Assembly

Ref. No.	Part No.	Description	No. Used	Ref. No.	Part No.	Description	No. Used
1	322-12	Screw-HH	4	21	3253-3	Washer-Lock	1
2	3253-4	Washer-Lock	4	22	3217-5	Nut	1
4	104-2532	Fan	1	23	67-8240	Bracket-Throttle	1
5	67-8510	Belt-Fan	1	24	321-6	Screw-HH	2
6	67-8390	Spacer-Fan	1	25	3256-56	Washer-Flat	1
7	67-8380	Pulley-Fan	1	26	3234-5	Screw-HHF	1
8	32128-33	Nut-HHF	4	27	67-8920	Shield-Heat	1
9	21-5640	Joint-Ball	1	28	321-39	Screw-HH	2
10	3219-14	Nut-Hex	3	29	70-2040	Guard-Trim	1
11	25-8640	Screw-Machine	1	30	67-9150	Support-Governor	1
12	3296-20	Nut-Lock	1	31	33094-00	Washer-Flat	1
13	43-3780	Swivel-Cable Throttle	1	32	33114-020	Screw-HH	1
14	67-8360	Governor	1	33	3234-11	Screw-HHF	2
15	3290-357	Nut-Lock, Flange	2	34	33115-020	Screw	1
16	67-8250	Rod-Throttle	1	35	3254-3	Washer-Lock	1
17	3253-12	Washer-Lock	1	36	18-2770	Cable-Ground	1
18	321-4	Screw-HH	1	37	104-4605	Spacer	1
19	3256-22	Washer-Flat	1	*38	104-4606	Fan Spacer ASM (Incl. 6,37)	1
20	2412-31	Clamp-Cable	1				

*Not Illustrated

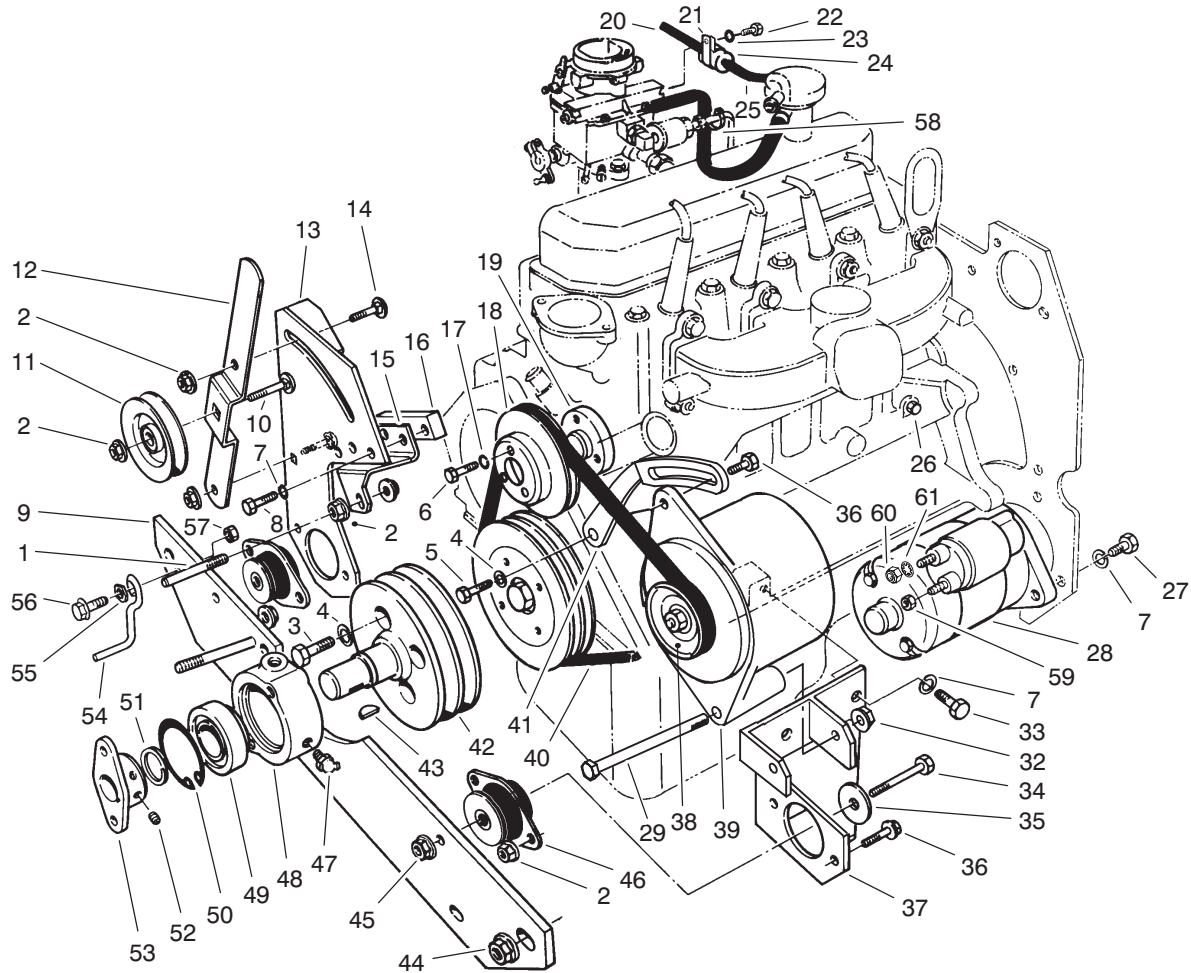

T-0922-2

Engine Assembly

Ref. No.	Part No.	Description	No. Used
1	21-1820	Stud-Retainer Belt	3
2	3290-357	Nut-Lock, Flange	12
3	33114-045	Screw-Metric	4
4	42-9850	Washer-Lock	5
5	33114-030	Screw-Metric	1
6	33113-025	Screw-Metric	3
7	48-9590	Washer-Lock	8
8	48-7800	Screw-Metric	3
9	75-9900	Support-Engine Front	1
10	3231-28	Bolt-Carriage	1
11	63-8140	Pulley-Idler	1
12	67-8890	Arm-Idler	1
13	67-8310	Mount-Engine Front RH	1
14	3231-22	Bolt-Carriage	2
15	67-8350	Bracket-Guide Belt	1
16	67-8340	Bar-Spacer	1
17	43-5930	Washer-Lock	3
†18		Pulley-Water Pump	1
19	67-8910	Spacer-Pulley	1
20	70-1920	Hose-Vacuum	1
†21	384007-S	Clamp-Valve	1
22	3250-29	Screw-PH	1
23	3256-21	Washer-Flat	1
†24	D4FZ-9C369-A	Fuel Separator	1

Ref. No.	Part No.	Description	No. Used
25	70-1910	Hose-Vac. Advance	1
†26	353055-S7	Plug-Water Drain	1
27	33115-030	Screw-Metric	3
†28	91AB-11000-JB	Starter	1
29	3212-17	Screw-HH	1
32	3296-38	Nut-Hex Flange	1
33	33115-025	Screw-Metric	2
34	324-11	Screw-HH	2
35	53-9480	Washer-Snubber	2
36	3234-11	Screw-Flange Lock	5
37	93-7663	Mount-Engine Front LH	1
38	D3JL-10A352-B	Pulley-Alternator	1
39	EZJL-10346-AB	Alternator	1
40	92-9785	Belt-Alternator	1
41	93-8489	Arm Adjust Alternator	1
42	67-8460	Pulley-Engine	1
43	3257-33	Key-Woodruff	1
44	32128-23	Nut-Lock, Flange	2
45	32128-37	Nut-Lock, Flange	2
46	53-9680	Mount-Engine	2
47	302-10	Fitting-Grease	1
48	43-3720	Collar Bearing	1
49	251-252	Bearing	1
50	32120-22	Ring-Retaining Int.	1

†Obtain from your local Ford Power Products Dealer.

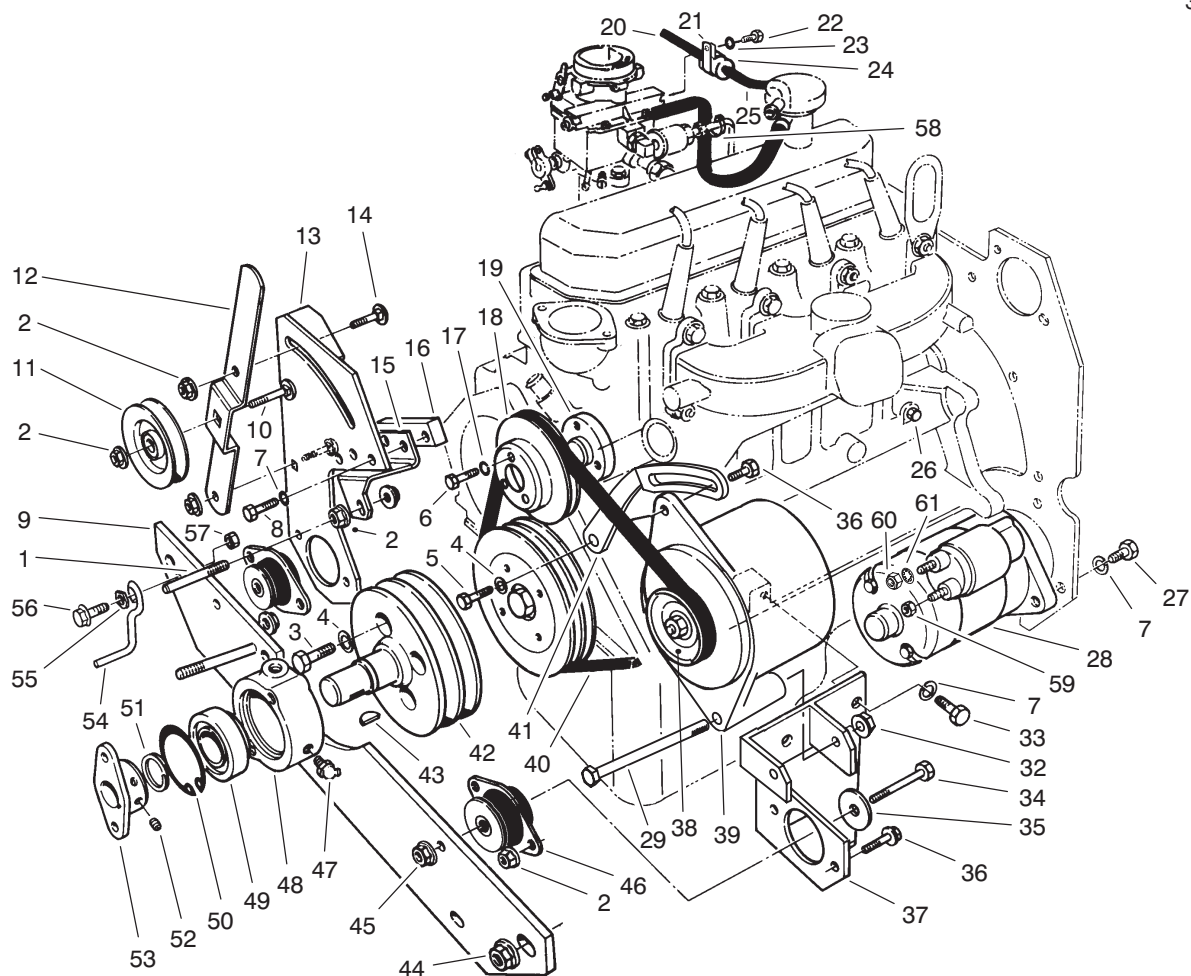

T-0922-2

Engine Assembly (Continued)

Ref. No.	Part No.	Description	No. Used	Ref. No.	Part No.	Description	No. Used
51	32120-69	Ring-Retaining Ext.	1	57	32153-2	Nut-Lock	1
52	3241-5	Screw-Sq. Hd. Set	2	58	3290-379	Cable-Tie	A/R
53	27-1960	Hub-Engine	1	59	48-7890	Nut	1
54	63-1400	Rod-Belt	1	60	33014-00	Nut	1
55	3290-224	Washer-Pyramidal	1	61	3254-2	Washer-Lock	1
56	3234-18	Screw-HHF	1				

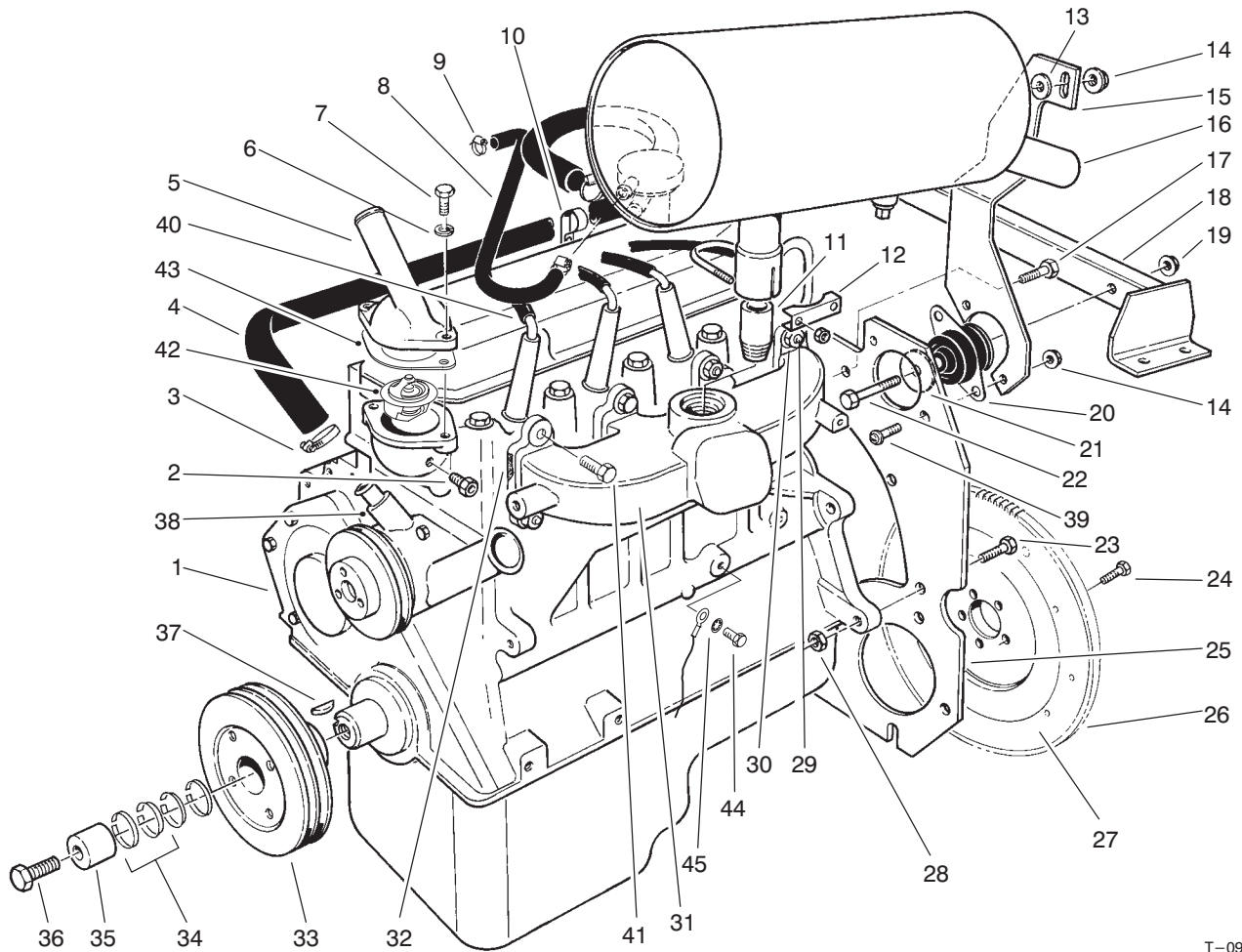

T-0923-3

Engine Assembly

Ref. No.	Part No.	Description	No. Used
‡1	Model VSG-413	Engine TYPE 6005A	1
2	70-1690	Adapter-Gauge Temp.	1
3	2412-119	Clamp-Hose	2
4	70-1670	Hose-Heater	1
5	67-8940	Connector-Outlet	1
†6	E630173-S71 M	Washer-Lock	2
†7	E6021 87-S72	Screw-Cap	2
8	70-2050	Hose-Breather	1
9	2412-108	Clamp	2
10	2412-39	Clamp-R	1
11	67-9130	Pipe-Muffler	1
12	2112-6	Clamp-Muffler	1
13	5-0652	Spacer	1
14	3290-357	Nut-Lock, Flange	5
15	67-8420	Bracket-Muffler	1
16	67-9120	Muffler	1
†17	N605799-S2	Bolt	2
18	67-8480	Support-Engine Rear	1
19	32128-37	Nut-Lock, Flange	2
20	53-9680	Mount-Engine	2
21	53-9480	Washer-Snubber	2
22	324-11	Screw-HH	2
†23	N800057-S2	Bolt	4

Ref. No.	Part No.	Description	No. Used
†24	D2RY-6379-A	Bolt	6
25	67-8440	Plate-Support Engine	1
†26	D8RZ-6384-A	Ring Gear-Flywheel	1
†27	89BM-6375-BA	Asm-Flywheel (Incl. Ref. #26)	1
†28	N620482-S2	Nut	4
†29	E805697-S76	Stud	6
†30	N620481-S2	Nut	6
†31	F5JL-9430-CA	Manifold-Exhaust	1
†32	89BM-9448-BA	Gasket-Manifold	4
†33	E7JL-6A312-AA	Pulley	1
†34	E7JL-6N300-AA	Locking Ring Set	2
†35	E7JL-6378-AB	Compression Ring	1
†36	E7JL-6K340-AA	Bolt	1
†37	Dory-6B316-A	Key	1
†38	92BX8591-CA	Kit-Water Pump (Incl. Pulley & Gasket)	1
39	3234-11	Screw-HHF	4
40	86-7921	Cover-Spark Plug Wire	4
41	33114-030	Screw-HH	2
†42	D4PZ-8575-A	Thermostat	1
†43	D1FZ-8255-B	Gasket	1
44	33115-020	Screw-HH	1
45	3254-3	Washer-Lock	1

†Obtain from your local Ford Power Products Dealer.
‡Note: Includes all Ford part numbers from all pages.

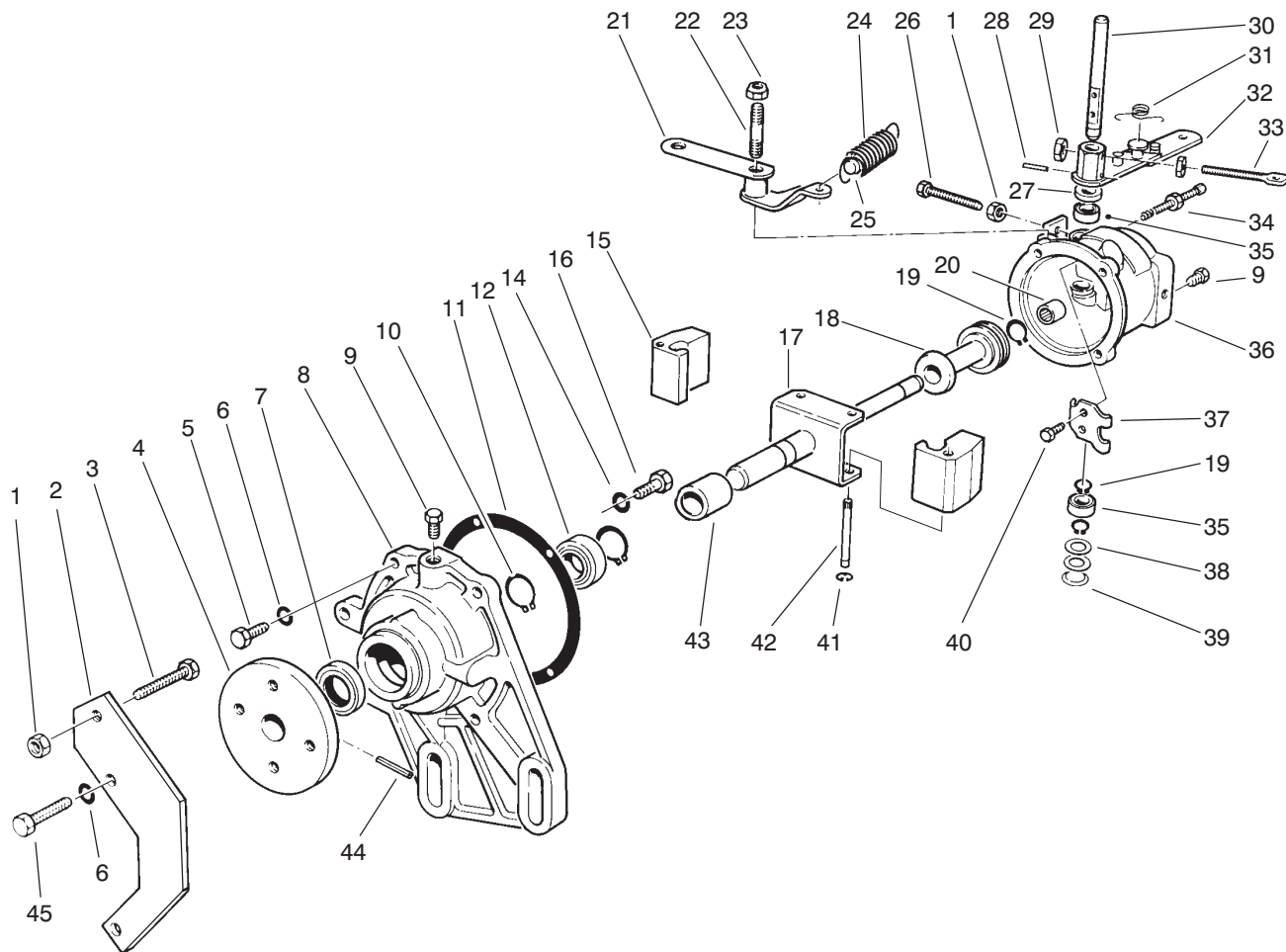

T-0933

Governor Assembly No. 67-8360

Ref. No.	Part No.	Description	No. Used
1	3219-1	Nut	2
2	70-2160	Bracket-Speed Stop	1
3	72-5920	Screw	1
4	67-8370	Hub	1
5	18-5620	Screw	2
6	18-5630	Washer-Lock	4
7	18-5580	Seal-Oil Front	1
8	104-2524	Cover-Governor	1
9	285-17	Plug-Pipe	2
10	18-5640	Ring-Retaining	2
11	18-5790	Gasket	1
12	70-2140	Bearing-Front	1
14	18-5770	Washer-Lock	2
15	70-2150	Flyweight	2
16	32113-14	Screw-HH	2
17	70-2110	Main Shaft & Yoke	1
18	70-2100	Asm-Sleeve & Bearing	1
19	18-5540	Ring-Retaining	3
20	72-5940	Bearing-Needle	1
21	70-2070	Lever-Speed Adjusting	1
22	70-2090	Stud-Pivot Lever	1
23	3296-5	Nut-Lock	1
24	72-5860	Spring-Governor	1

Ref. No.	Part No.	Description	No. Used
25	72-5850	Pin-Force Idle	1
26	72-5930	Screw	1
27	71-4780	Seal-Oil Rocker Shaft	1
28	18-5750	Pin	1
29	3219-2	Nut	2
30	72-5890	Shaft-Rocker	1
31	18-5410	Spring-Torsion	1
32	72-5880	Asm-Throttle Lever (Incl. Ref. #31)	1
33	72-5870	Eyebolt	1
34	72-5910	Asm-Bumper Screw	1
35	18-5450	Bearing	2
36	70-2080	Body	1
37	18-5520	Lever-Rocker	1
38	18-5440	Spacer	2
39	18-5430	Plug-Expansion	1
40	18-5530	Screw & Lockwasher	2
41	18-5670	Retainer-Pin Pivot	2
42	18-5660	Pin-Pivot Flyweight	2
43	70-2120	Spacer	1
44	32121-51	Pin-Hub To Shaft	1
45	71-4770	Screw	2

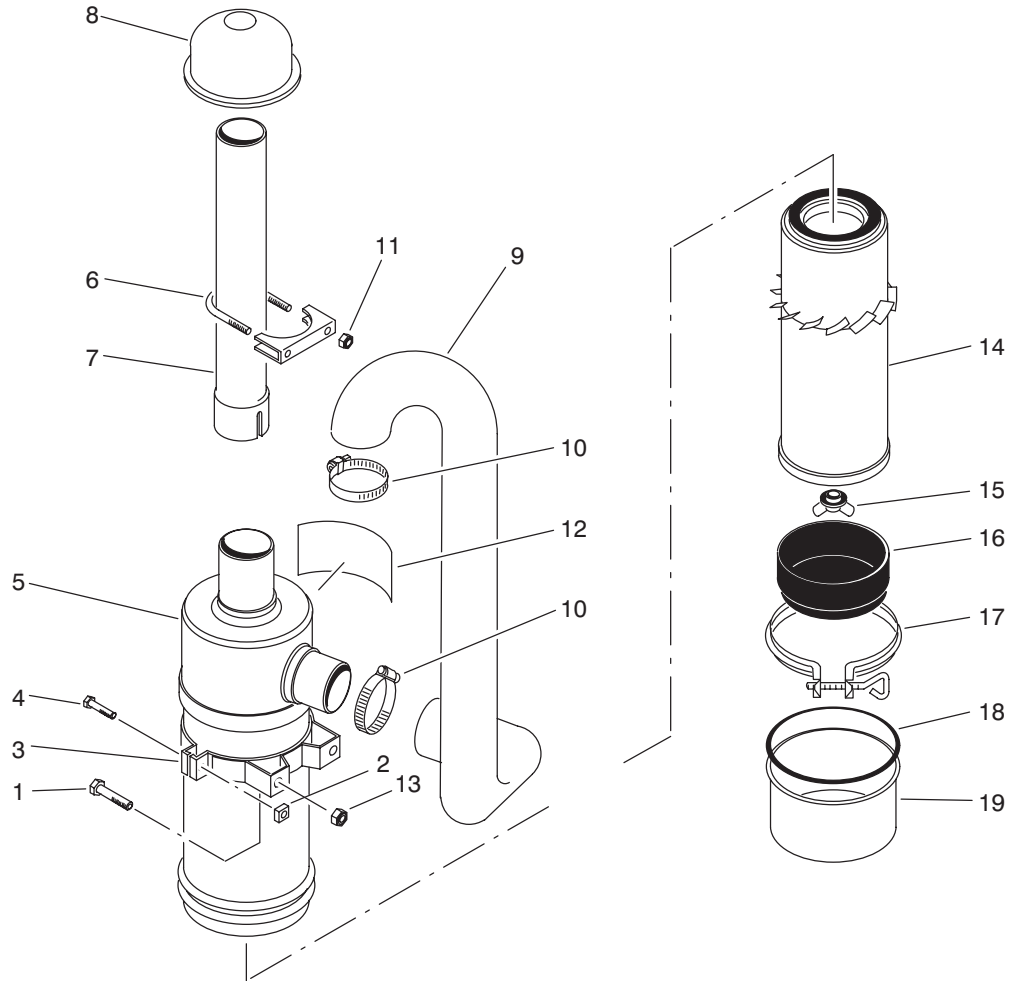

T-0934-1

Air Cleaner Assembly

Ref. No.	Part No.	Description	No. Used
1	322-3	Screw-HH	4
2	32107-11	Nut	2
3	27-7170	Asm-Band (Incl. Ref. #2 & 4)	2
4	3258-19	Round Hd. Machine Screw	2
5	27-7100	Asm-Air Cleaner (Incl. Ref. #12, 14-19)	1
6	20-4840	Muffler Clamp (Incl. Ref. #11)	1
7	43-3810	Tube Air Cleaner	1
8	27-7180	Asm-Cap, Air Inlet	1
9	82-5590	Hose-Air Cleaner	1

Ref. No.	Part No.	Description	No. Used
10	2412-42	Hose Clamp	2
11	3217-6	Nut	2
12	27-7160	Decal-Instructions	1
13	32128-20	Nut-Lock, Flange Hd.	4
14	27-7110	Asm-Element	1
15	27-7120	Asm-Nut & Gasket	1
16	27-7140	Skirt-Baffle	1
17	27-7130	Asm-Clamp	1
18	80-3330	Gasket	1
19	27-7150	Asm-Cup	1
*	95-3093	Kit-400 Hour Filter (Incl. Ref. #14)	1

*Not Illustrated

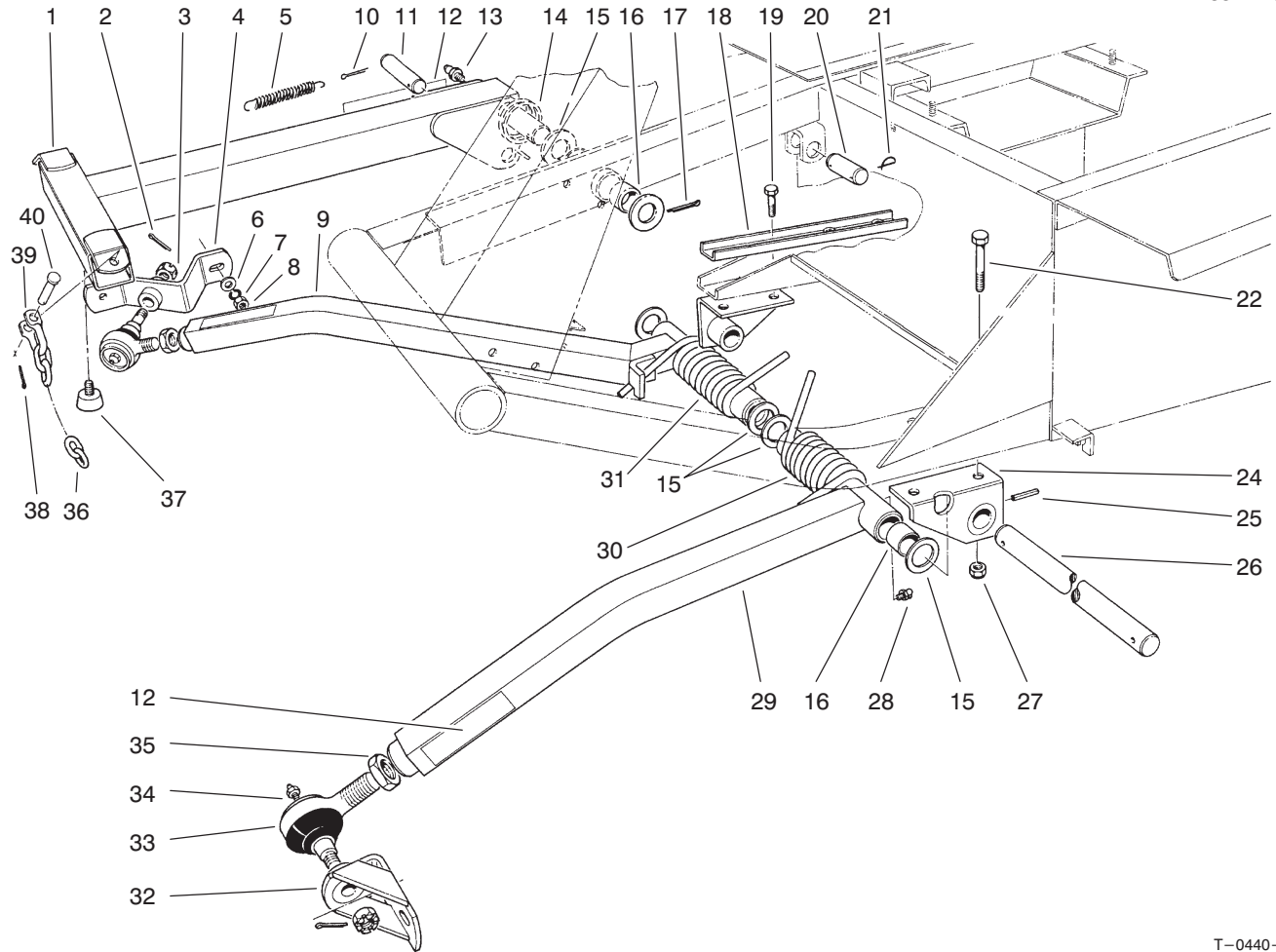

T-0440-5

Push Arm Assembly

Ref. No.	Part No.	Description	No. Used	Ref. No.	Part No.	Description	No. Used
1	66-6370	Lift Arm	1	21	5-3126	Spring Pin	3
2	3272-11	Cotter Pin	2	22	324-12	Screw-HH	2
3	32136-2	Nut	2	24	21-2860	Push Arm Bracket	2
4	21-3020	Ball Joint Mount	1	25	32121-84	Roll Pin	2
5	21-1830	Spring Tension	1	26	21-2990	Shaft Pivot	1
6	3256-25	Washer-Flat	1	27	32128-42	Nut-Flange	4
7	3253-6	Washer-Lock	2	28	302-33	Grease Fitting	2
8	3217-8	Full Nut	2	29	21-2960	Push Arm LH (Incl. Ref. #16 & 28)	1
9	66-7150	Push Arm RH (Incl. Ref. #16 & 28)	1	30	21-2900	Spring-Torsion LH	1
10	3272-24	Cotter Pin	1	31	21-2890	Spring-Torsion RH	1
11	24-9510	Pin	1	32	21-3050	Ball Joint Mount LH	1
12	55-4300	Warning Decal	3	33	86-8100	Asm-Ball Joint	2
13	302-5	Grease Fitting	1	34	302-5	Grease Fitting	2
14	46-8840	Spring Lift Arm	1	35	21-3000	Jam Nut	2
15	5-1754	Washer	6	36	3-1365	Chain-Lift	3
16	256-126	Bushing	6	37	67-9800	Bumper	1
17	3272-33	Cotter Pin	1	38	3272-10	Cotter Pin	6
18	23-1950	Support Reinforcement	1	39	5-2942	Shackle	1
19	324-4	Screw-HH	2	40	283-10	Pin	1
20	3-7292	Pin	1				

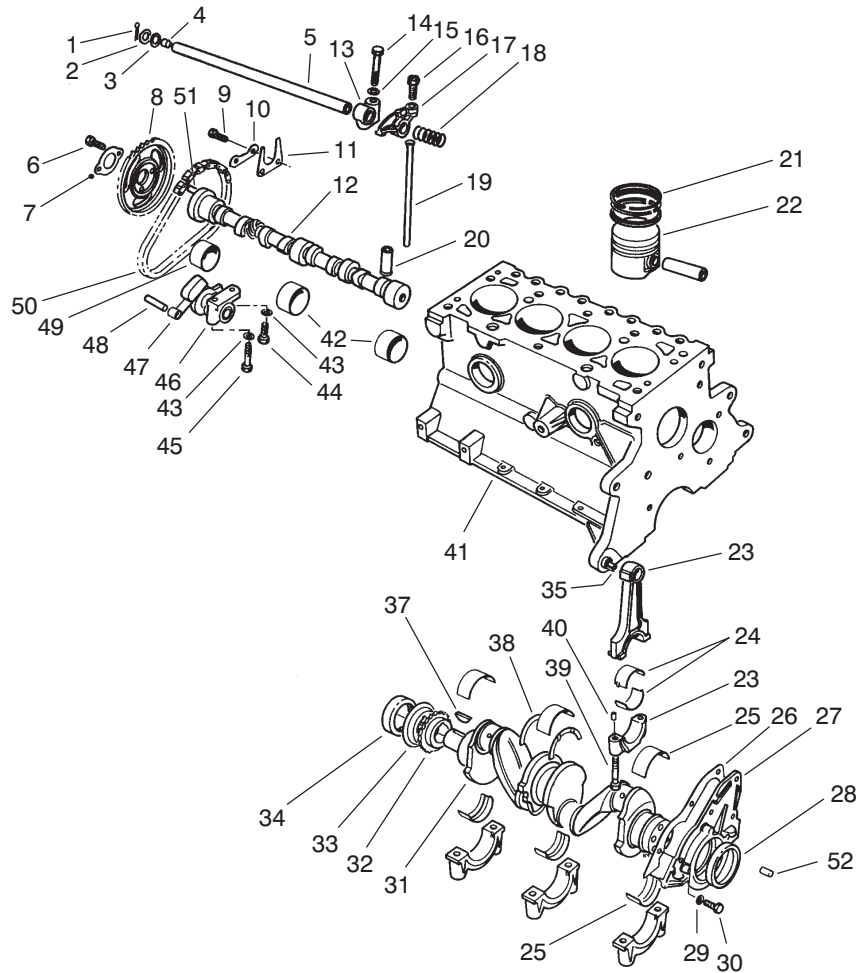

T-1004-1

Crankshaft & Camshaft Assembly

Ref. No.	Part No.	Description	No. Used	Ref. No.	Part No.	Description	No. Used
1	72025-S7	Cotter Pin	2	22	89BM-6102-DA	Asm-Piston STD. (Inc. Ref. #21)	4
2	77BM-6598-AB	Washer-Spring	2	*	89BM-6102-EA	Asm-Piston .020 OS. (Inc. Ref. #21)	A/R
3	DORY-6590-A	Washer-Flat	2	*	89BM-6102-FA	Asm-Piston .040 OS. (Inc. Ref. #21)	A/R
4	357966-S	Plug-Rocker Arm Shaft	2	23	89BM-6200-AD	Asm-Connecting Rod	4
5	89BM-6A557-AA	Asm-Rocker Arm Shaft (Incl. Ref. #4)	1	24	89BM-6211-AA	Bearing-Rod STD.	8
6	E602351-S72	Bolt	2	*	89BM-6211-BA	Bearing-Rod .001 U.S.	A/R
7	DORY-6258-A	Retainer	1	*	89BM-6211-CA	Bearing-Rod .010 U.S.	A/R
8	77BM-6256-AA	Sprocket-Camshaft	1	*	89BM-6211-DA	Bearing-Rod .020 U.S.	A/R
9	N602166-S2	Bolt	2	*	89BM-6211-EA	Bearing-Rod .030 U.S.	A/R
10	DORY-6255-A	Retainer	1	25	89BM-6333-AA	Bearing-Crank Upper STD. OD STD. ID	5
11	DORY-6269-A	Plate-Thrust	1	*	89BM-6331-AA	Bearing-Crank Lower STD. OD STD. ID	5
12	89BM-6251-AA	Camshaft	1	*	89BM-6333-BA	Bearing-Crank Upper STD. OD .005 US. ID	A/R
13	77BM-6531-BB	Support-Rocker Shaft	4	*	89BM-6331-BA	Bearing-Crank Lower STD. OD .005 US. ID	A/R
14	E800509-S72	Bolt-Rocker Support	4	*	89BM-6333-CA	Bearing-Crank Upper STD. OD .010 US. ID	A/R
15	E630031-S101	Washer	4				
16	DORY-6549-B	Screw	8				
17	89BM-6529-AB	Valve Rocker Arm-R.H. (Inc. Ref. #16)	4				
*	89BM-6K528-AB	Valve Rocker Arm-L.H. (Inc. Ref. #16)	4				
18	DORY-6587-A	Spring-Locating	3				
19	89BM-6565-AA	Rod-Valve Push	8				
20	89BM-6500-AA	Tappet-STD.	8				
21	89BM-6148-DA	Ring Set-STD.	4				
*	89BM-6148-EA	Ring Set-.020 OS.	A/R				
*	89BM-6148-FA	Ring Set-.040 OS.	A/R				

*Not Illustrated

Note: Order parts from your local Ford Power Products Dealer.

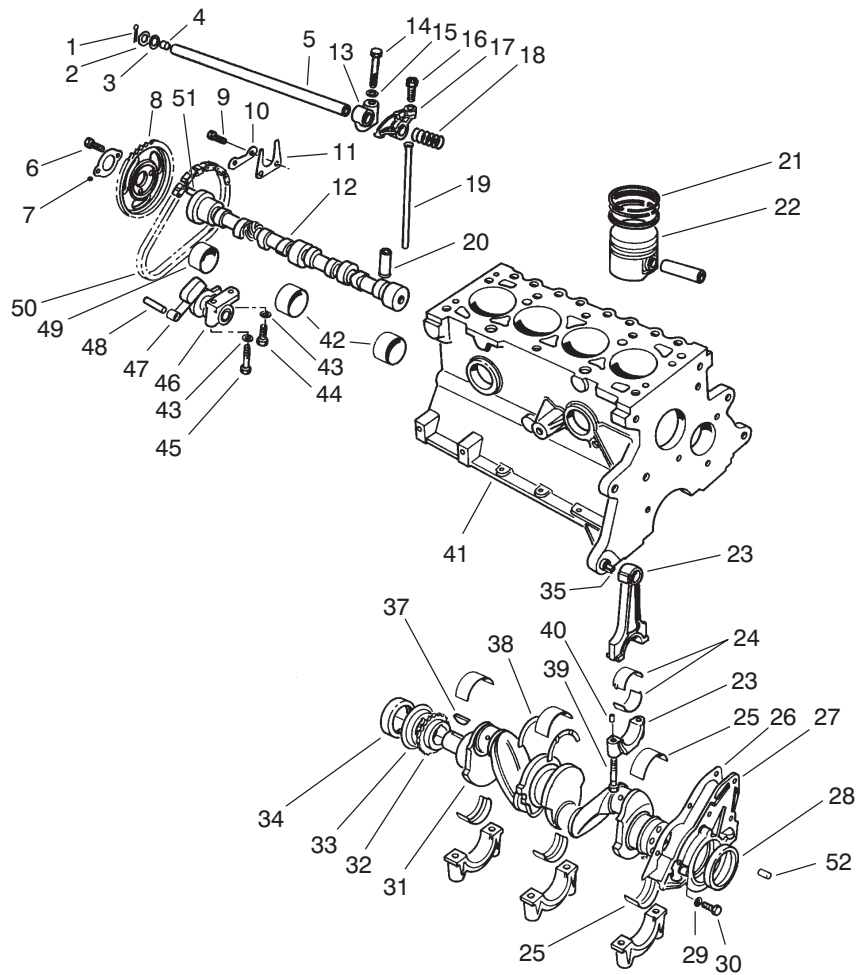

T-1004-1

Crankshaft & Camshaft Assembly (Continued)

Ref. No.	Part No.	Description	No. Used	Ref. No.	Part No.	Description	No. Used
*25	89BM-6333-DA	Bearing-Crank Upper 015 OD STD. ID	A/R	27	86BM-6K318-AA	Asm-Retainer, Rear	1
*	89BM-6331-DA	Bearing-Crank Lower 015 OD STD. ID	A/R	28	86HM-6701-A1A	Seal Crankshaft Rear	1
*	89BM-6333-EA	Bearing-Crank Upper STD. OD .020 US. ID	A/R	29	E630173-S71M	Lockwasher	4
*	89BM-6331-EA	Bearing-Crank Lower STD. OD .020 US. ID	A/R	30	E602187-S72	Bolt	4
*	89BM-6333-FA	Bearing-Crank Upper STD. OD .030 US. ID	A/R	31	89BM-6303-DA	Asm-Crankshaft	1
*	89BM-6331-FA	Bearing-Crank Lower STD. OD .030 US. ID	A/R	32	DORY-6306-A	Sprocket	1
*	89BM-6333-GA	Bearing-Crank Upper .015 OS. OD .010 US. ID	A/R	33	D8RZ-6310-A	Slinger Oil	1
*	89BM-6331-GA	Bearing-Crank Lower .015 OS. OD .010 US. ID	A/R	34	83BM-6700-A4A	Seal-Front Cover	1
*	89BM-6333-HA	Bearing-Crank Upper .015 OS. OD .020 U.S. ID	A/R	35	70HM-6397-AA	Dowel	2
*	89BM-6331-HA	Bearing-Crank Lower .015 OS. OD .020 US. ID	A/R	37	D0RY-6B316-A	Key-Woodruff	1
26	89BM-6344-BA	Gasket Rear Retainer	1	38	89BM-6A341-AA	Washer-Bearing Thrust STD.	2
				*	89BM-6A341-BA	Washer-Bearing Thrust .015 OS.	A/R
				39	89BM-6214-DB	Bolt-Connecting Rod	8
				40	116336-ES100	Dowel Pin-Rod	8
				41	89BM-6011-DA	Cylinder Block	1
				42	DORY-6261-A	Bearing-STD. ID STD. OD	2
				*	DORY-6262-B	Bearing-STD. ID +.020 OD	A/R
				43	34805-S8	Lockwasher	2
				44	E602166-S72	Bolt	1
				45	E600116-S72	Bolt	1
				46	DIFZ-6284-A	Tensioner	1

*Not Illustrated

Note: Order parts from your local Ford Power Products Dealer.

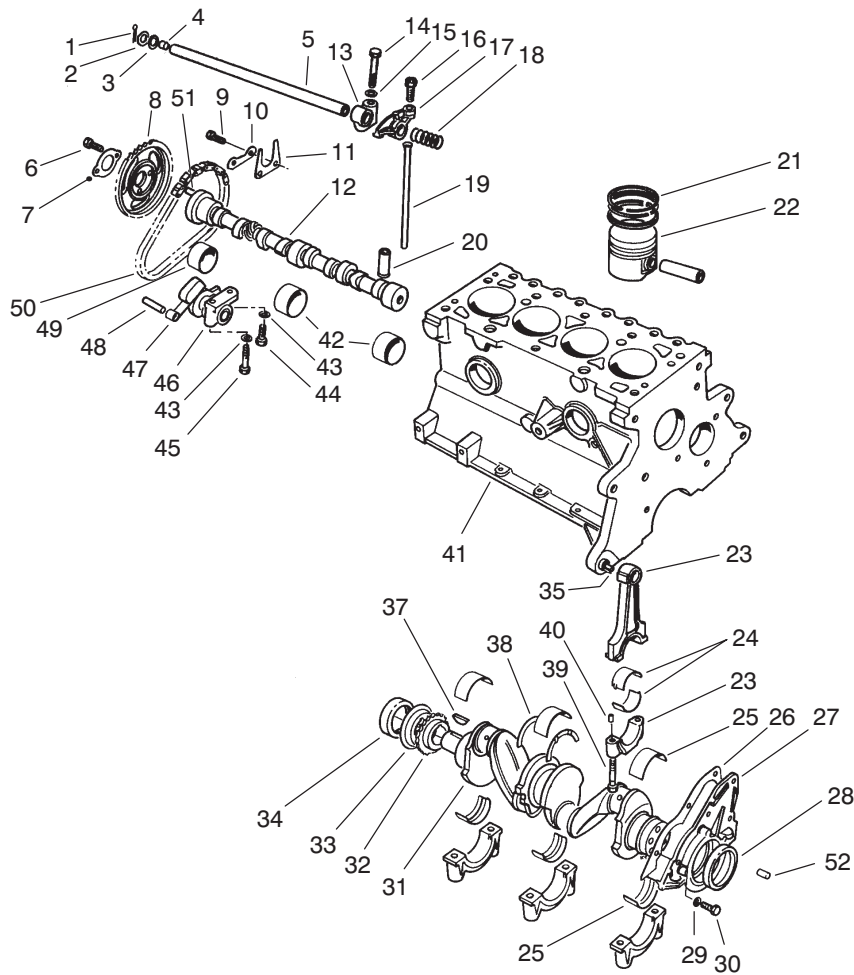

T-1004-1

Crankshaft & Camshaft Assembly (Continued)

Ref. No.	Part No.	Description	No. Used
47	77BM-6K255-AC	Arm-Tensioner	1
48	E43-CP-1	Pin	1
49	DORY-6261-A	Bearing-STD. ID STD. OD	1
*	DORY-6261-B	Bearing-STD. ID +.020 OD	A/R
50	DORY-6268-A	Chain	1

Ref. No.	Part No.	Description	No. Used
51	E93A-6253-A	Dowel	1
52	E-840161-S	Dowel	1
*	93BX-6014-AA	Kit-Gasket, Upper (Less Head Gasket)	1
*	89BM-6051-C2B	Head Gasket	1
*	93BX-6013-BA	Kit-Gasket, Lower	1

*Not Illustrated

Note: Order parts from your local Ford Power Products Dealer.

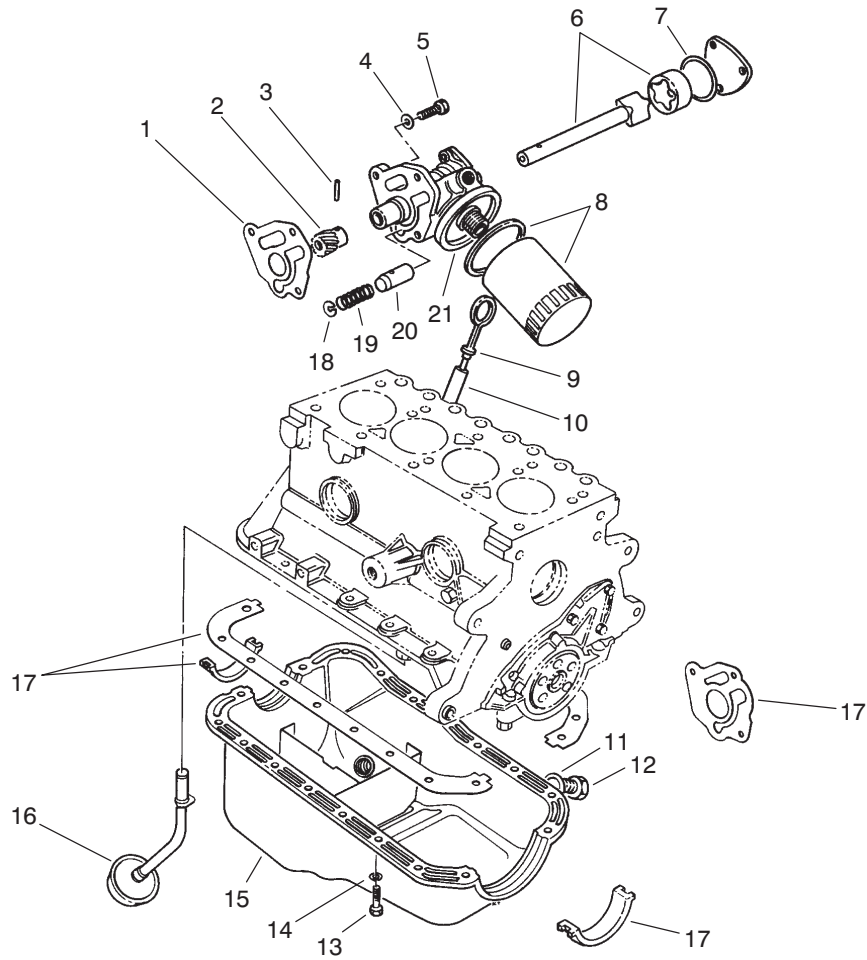

T-1003-1

Oil Pump & Filter Assembly

Ref. No.	Part No.	Description	No. Used	Ref. No.	Part No.	Description	No. Used
1	96BM-6659-A1A	Gasket-Oil Pump	1	12	E9DZ-6730-B	Plug-Oil Drain	1
2	DORY-6652-A	Gear	1	13	E602165-S72	Bolt	18
3	72432-S	Pin-Drive Gear	1	14	34805-S8	Lockwasher	18
4	E630173-S71M	Lockwasher	3	15	86BM-6675-AA	Oil Pan	1
5	E800519-S72	Bolt	3	16	86BM-6617-AA	Asm-Oil Pickup Tube	1
6	DIFZ-6608-B	Rotor & Shaft	1	17	A850X-6013-A2A	Kit-Gasket Seal	1
7	116682-ES	Seal Cover Plate	1	18	DORY-6666-A	Plug	1
8	95-3304	Filter-Oil	1	19	DORY-6670-A	Spring	1
9	92BM-6750-AA	Indicator-Oil Level	1	20	DORY-6674-A	Plunger	1
10	89BM-6784-AA	Tube Oil Level Indicator	1	21	D8RZ-6600-A	Pump-Oil	1
11	E9DZ-6734-B	Gasket Oil Drain Plug	1				

Note: Order parts from your local Ford Power Products Dealer.

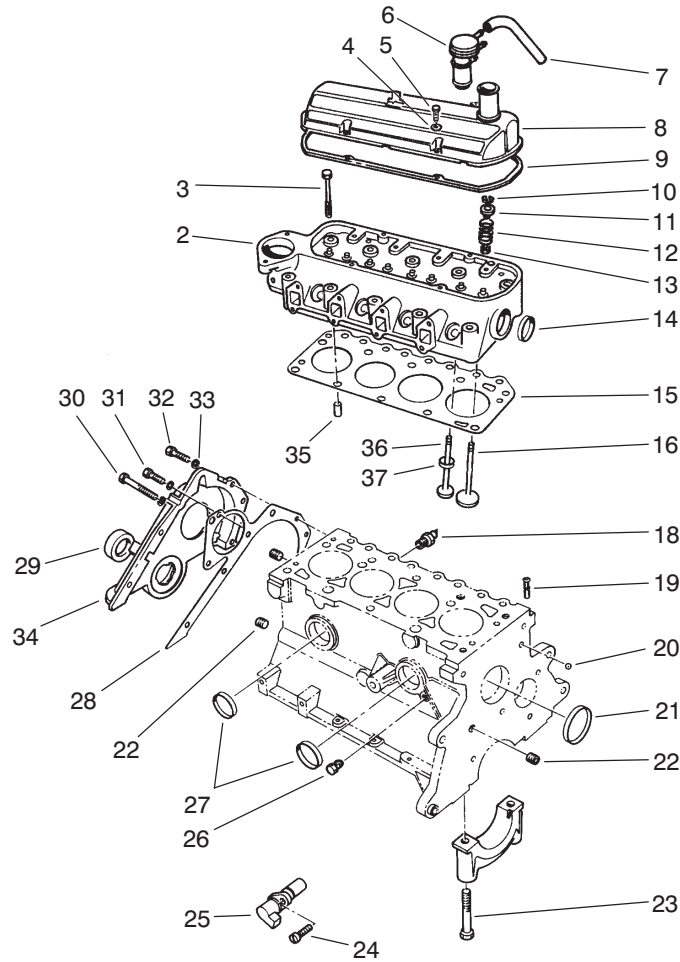

T-1002-1

Cylinder Head & Valve Assembly

Ref. No.	Part No.	Description	No. Used
2	89BM-6049-DD	Asm-Cylinder Head	1
3	89BM-6065-DA	Bolt-Cylinder Head	10
4	E630024-S201	Washer-Flat	4
5	E800516-S72	Screw-Rocker Cover	4
6	84BF-6K614-CA	Cap-Oil Fill	1
7	E9JL-6K609-AA	Hose-PCV	1
8	91BM-6582-GA	Cover-Rocker Arm	1
9	77BM-6584-CA	Gasket-Cover	1
10	88WM-6518-AA	Lock Valve Spring	16
11	89BM-6A536-AA	Retainer	8
12	89BM-6513-AA	Spring-Valve	8
13	88WM-6571-BB	Seal-Valve Stem	8
14	DORY-6026-A	Plug	1
15	89BM-6051-C2B	Gasket-Cylinder Head	1
16	89BM-6507-BA	Valve-Intake-Std.	4
*	89BM-6507-BC	Valve-Intake .040mm O.S.	A/R
18	E7RZ-9278-A	Switch Oil Pressure	1
19	D8RZ-6767-A	Adapter	1
20	E890100-S	Plug-Ball-Oil Gallery	1

Ref. No.	Part No.	Description	No. Used
21	DORY-6026-A	Plug	1
22	F1ZZ-6026-A	Plug	3
23	D1FZ-6345-A	Bolt-Bearing Cap	10
24	E802666-S72	Screw	1
25	89BF-6C315-AB	Transducer	1
26	353055-S7	Plug	1
27	DORY-6026-A	Plug	2
28	D8RZ-6020-A	Gasket-Front Cover	1
29	83BM-6700-A4A	Seal-Front Cover	1
30	E800518-S72	Bolt	1
31	E600113-S72	Bolt	3
32	E800512-S72	Bolt	4
33	E832108-S71M	Lockwasher	8
34	95BM-6019-AC	Asm-Cover & Seal (Incl. Ref. #29)	1
35	E840126S	Dowel	2
36	89BM-6505-EA	Valve-Exhaust .040mm O.S.	A/R
*	89BM-6505-CA	Valve-Exhaust Std.	4
37	89BM-6057-A2E	Insert-Exhaust Seat	4

*Not Illustrated

Note: Order parts from your local Ford Power Products Dealer.

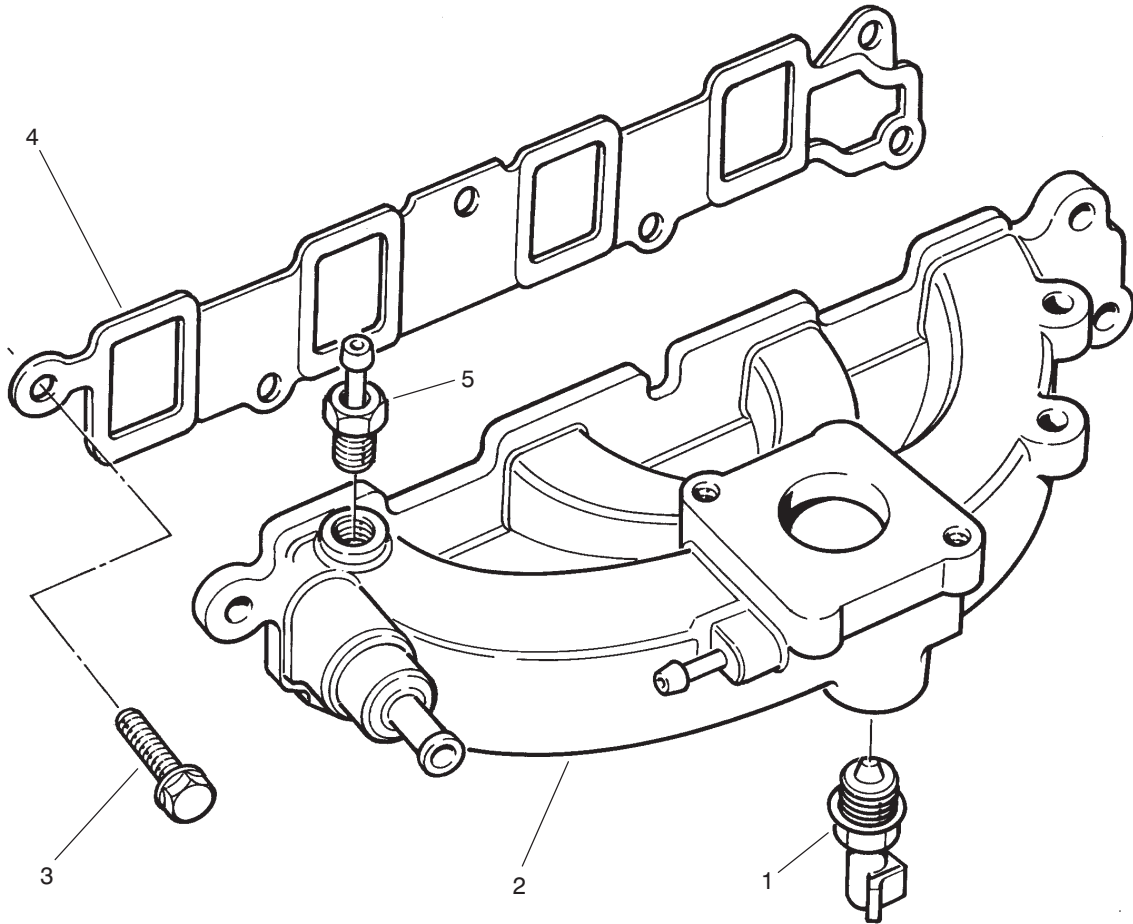

T-1176-1

Manifold Assembly

Ref. No.	Part No.	Description	No. Used
1	E1AZ-12A648-A	Sensor-Temp. Water	1
2	89BF-9424-AD	Manifold-Intake	1
3	E800157-S72	Bolt	6

Ref. No.	Part No.	Description	No. Used
4	89BM-9441-AB	Gasket-Intake Manifold	1
5	77BF-9K442-AA	Adapter-Vacuum	1

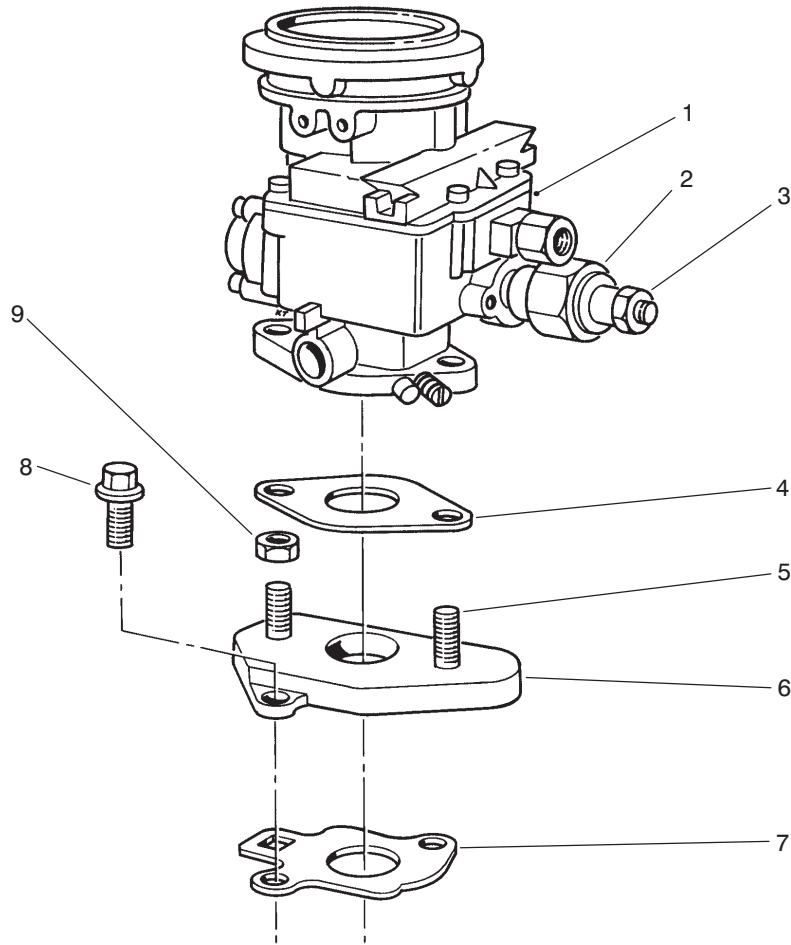

T-0999-1

Carburetor Assembly

Ref. No.	Part No.	Description	No. Used
1	F8JL-9510LA	Asm-Carburetor	1
2	84FB-9K765-BA	Solenoid	1
3	N621903-S2	Nut & Washer	1
4	E5JL-9447-BA	Gasket	1
5	E804216S	Stud	2

Ref. No.	Part No.	Description	No. Used
6	E8JL-9A589-CB	Adapter	1
7	87BF-9447-BA	Gasket	1
8	N800055-S	Bolt	2
9	N620041-S51	Nut	2

Note: Order parts from your local Ford Power Products Dealer.

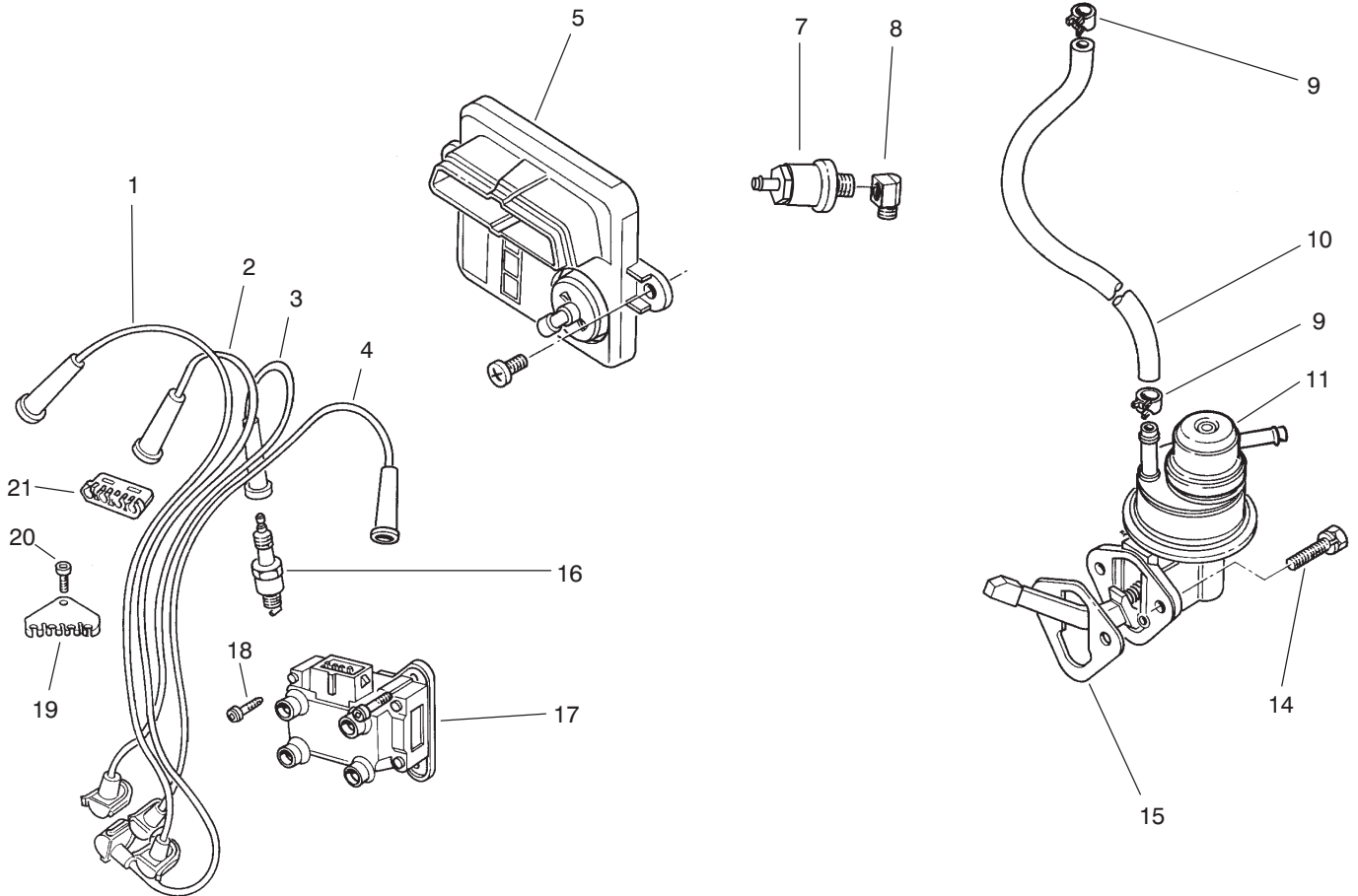

T-1233-2

Ignition & Fuel Pump Assembly

Ref. No.	Part No.	Description	No. Used
1	89BF-12287-AC	Wire-Spark Plug #4	1
2	89BF-12284-AD	Wire-Spark Plug #3	1
3	89BF-12283-AD	Wire-Spark Plug #2	1
4	88BF-12286-AD	Wire-Spark Plug #1	1
5	89FB-12A297-GA	Module-Ignition	1
†7	FG778-B	Filter-Fuel (Motorcraft)	1
8	370829-S101	Elbow	1
9	380882-S32	Clamp-Fuel Hose	A/R
10	381103-S180A	Hose-Fuel	1
11	83BF-9350-AA	Fuel Pump	1

Ref. No.	Part No.	Description	No. Used
14	N602551-S2	Screw & Washer	2
15	83BM-9417-A1A	Gasket-Fuel Pump	1
16	AGRF22	Spark Plug	1
*	AGSF22C	(Motorcraft)	4
17	96BF-12024-A1A	Asm-Coil & Bracket	1
18	E804335-S201	Screw	3
19	89BF-12297-AA	Separator-Wire	1
20	E802166-S76	Screw	1
21	E865648-S	Separator-Wire	1

*Not Illustrated

Note: Order parts from your local Ford Power Products Dealer.

†For use on Serial No. 40501 & UP

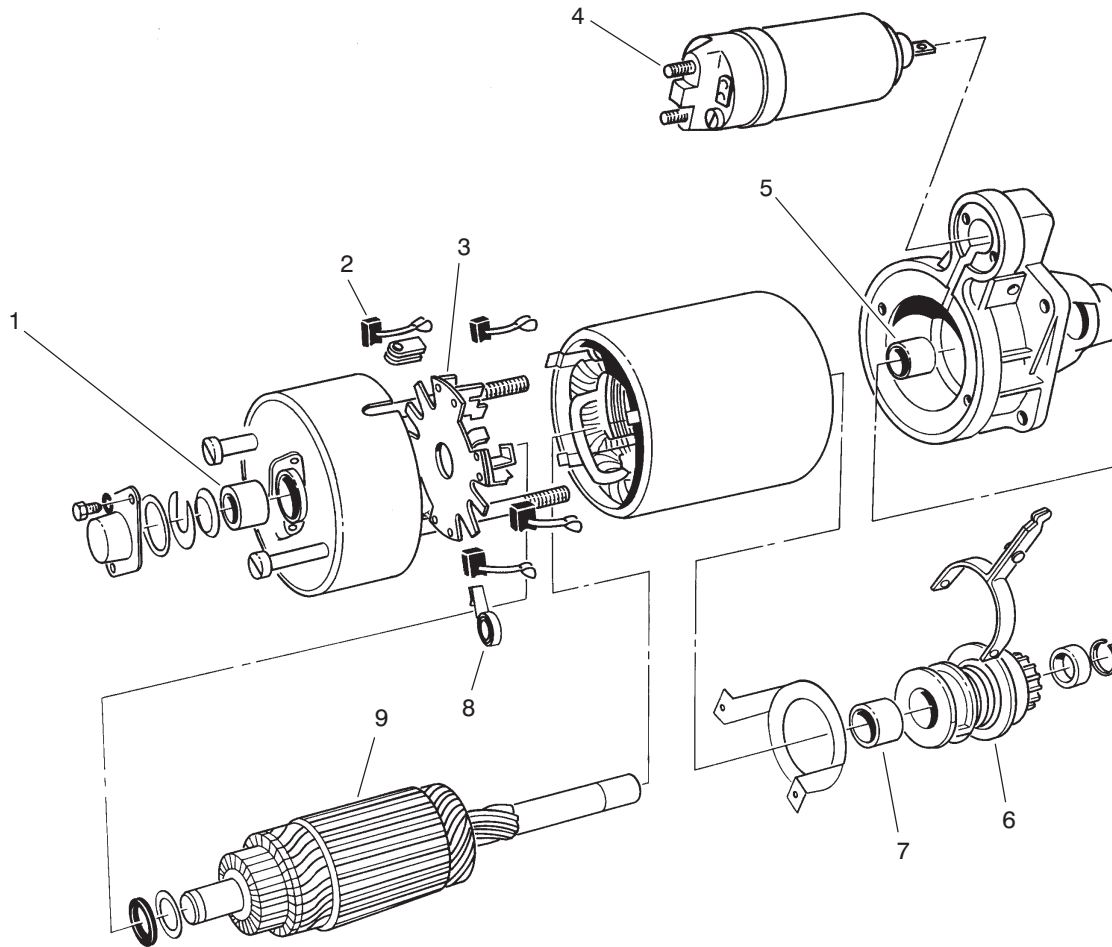

T-1005-1

Starter Motor Assembly (91AB11000JB)

Ref. No.	Part No.	Description	No. Used
1		Bushing—Brush End	1
2		Brush Set	1
3		Holder—Brush	1
4	F7JL-11450-AA	Solenoid—Starter	1
5		Bushing—Drive End	1

Ref. No.	Part No.	Description	No. Used
6	F7JL-11350-BA	Kit—Starter Drive	1
7		Bushing—Starter Drive	1
8		Spring—Brush	4
9		Kit—Armature Install	1
*		Kit—Wiring, Service	1

*Not Illustrated

Note: Order parts from your local Ford Power Products Dealer.

PRODUCT CHANGES

In an effort to make improvements available to TORO owners as quickly as possible minor changes are incorporated into Toro's products from time to time that do not become immediately shown in the Parts Catalog. If such a change has been made in your unit which is not reflected in your manual see your TORO Distributor or his Authorized TORO Service Dealer for information and part numbers.

IDENTIFICATION AND ORDERING

MODEL AND SERIAL NUMBERS

The Groundsmaster 345 has two identification numbers; a model number and a serial number. The two numbers are stamped on a plate which is located on the main frame under the seat. In any correspondence concerning the Groundsmaster 345, supply model and serial numbers to assure that correct information and replacement parts are obtained.

To order replacement parts from an Authorized TORO Service Dealer supply the following information:

1. Model and serial number of the Groundsmaster 345.
2. Part number description and the quantity of part(s) desired.

NOTE: Do not order by reference number if a parts catalog is being used; use the PART NUMBER.

TABLE OF CONTENTS

Description	Page	Description	Page
Main Frame Asm	1-3	Valve and Cylinder Asm	25
Instrument Panel Asm	4	Hydraulic Lift Cylinder Asm	
Electrical Schematic	5	No. 100-6586 (2-1/2" Bore)	26
Radiator & Hood Asm	6-7	Hydraulic Lift Cylinder Asm	
Interlock Asm	8	No. 100-6591 (3" Bore)	27
Power Take Off Asm	9-10	Control Valve Asm No. 43-1710	28
Brake Pedal Asm	11	Engine Asm	29-32
Power Steering Asm	12	Governor Asm No. 67-8360	33
Power Steering & Valve Asm No. 92-7308	13	Air Cleaner Asm	34
Hydraulic Schematic	14	Push Arm Asm	35
Front Axle and Fuel Tank Asm	15	Crankshaft & Camshaft Asm	36-38
Front Axle Asm No. 86-9600	16-17	Oil Filter & Pump Asm	39
Brake Asm	18	Cylinder Head & Valve Asm	40
Rear Wheel & Axle Asm	19	Manifold Asm	41
Hydraulic Steering Cylinder Asm		Carburetor Asm	42
No. 92-7828	20	Ignition & Fuel Pump Asm	43
Hydrostatic Transmission	21-22	Starter Motor Asm	44
Transmission Asm No. 92-8947	23-24		

Maintenance Record

Date								

Maintenance Record

Date								

