



TX Platform

Gasoline-Powered TX Compact Utility Loader

Model No. 22475—Serial No. 270000001 and Up

Model No. 22476—Serial No. 270000001 and Up

Installation Instructions

Safety

General Operation

- Do not modify the platform or use it on non-approved machines.
- Ensure that the platform is properly attached to the machine and is in good working order prior to use.
- Allow only the machine operator on the platform.
- Do not allow use of the platform by untrained operators.
- Use appropriate personal protective apparatus for eyes, feet, hands, and head.
- Look behind and down before backing up to be sure of a clear path.
- Use extra care when operating in reverse.
- Dismount and latch the platform in the transport position when loading and unloading the machine.
- Do not place your feet under the platform.
- Slow down before turning. Sharp turns on any terrain may cause loss of control.
- Do not step off of the platform with the load raised.
- Keep your hands, feet, hair, and loose clothing away from any moving parts.
- Do not try to stabilize the traction unit by putting your foot on the ground.
- Do not operate platform on rough and uneven terrain.
- Ensure that you operate the platform in areas where there are no obstacles in close proximity to the operator. Failure to maintain adequate distance from trees, walls, and other barriers may result in injury as the platform backs up or turns during operation if the operator is not attentive to the surroundings. Only operate the unit in areas where there is sufficient clearance for the operator to safely maneuver the platform.
- Ensure that the area is clear of other people before operating the traction unit with the platform. Stop the traction unit if anyone enters the area.
- Do not exceed the rated operating capacity, as the traction unit with the platform may become unstable which may result in loss of control.

Service

- Stop the engine before performing any service, repairs, maintenance, or adjustments
- Keep nuts and bolts tight. Keep equipment clean and in good condition.
- Never tamper with safety devices. Check safety systems for proper operation before each use.
- Stop and inspect the equipment if you strike an object. Make any necessary repairs before restarting.
- Use only genuine replacement parts to ensure that original standards are maintained.



Safety and Instructional Decals



Safety decals and instructions are easily visible to the operator and are located near any area of potential danger. Replace any decal that is damaged or lost.

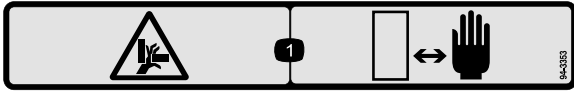

94-3353

decal94-3353

1. Crushing hazard of hand—keep hands away.



1

58-6520

decal58-6520

1. Grease



112-2744

decal112-2744

1. Read the *Operator's Manual*.
2. Platform locked in the storage position.
3. Lift the platform up to unlock.
4. Lower the platform from the unlocked position to use.
5. Warning—read the *Operator's Manual*.
6. Tipping hazard—do not step off the platform with a raised load.

Installation

Loose Parts

Use the chart below to verify that all parts have been shipped.

Procedure	Description	Qty.	Use
1	No parts required	–	Prepare the traction unit.
2	Platform assembly	1	Install the platform.
	Bolt (1/2 x 1-1/2 inches)	4	
	Flange-head nut (1/2 inch)	4	
3	Counterweight	1	Install the counterweight (TX 500 series traction units only).
	Bolt (1/2 x 1-1/4 inches)	4	
	Washer	4	
4	No parts required	–	Install the decal.
5	Handle	1	Install the handle.
	Flange-head bolts (5/16 x 3/4 inch)	2	

1

Preparing the Traction Unit

No Parts Required

Procedure

1. Stop the engine, lower the loader arms, set the parking brake, and remove the key.
2. Wash all dirt and debris from the traction unit.
3. If you are installing this kit on a TX 400 series traction unit, remove the counterweights and their fasteners from the rear of the traction unit and store them in a safe location (Figure 1).

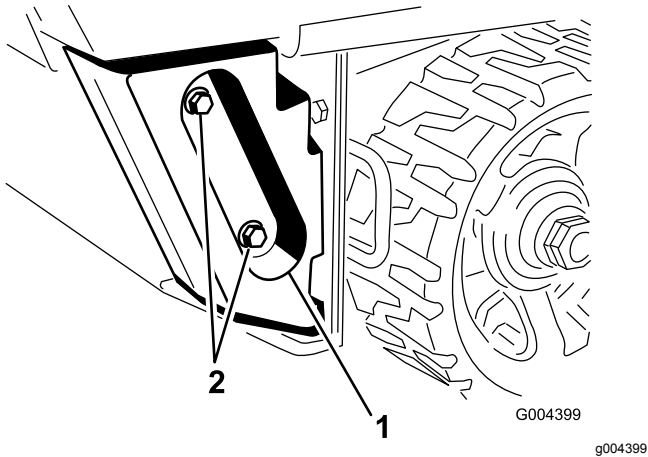

Figure 1

Left counterweight not shown.

1. Counterweight
2. Fasteners

2

Installing the Platform

Parts needed for this procedure:

1	Platform assembly
4	Bolt (1/2 x 1-1/2 inches)
4	Flange-head nut (1/2 inch)

Procedure

1. Check and tighten the bottom 2 bolts securing the lower rear panel to the frame (Figure 2).

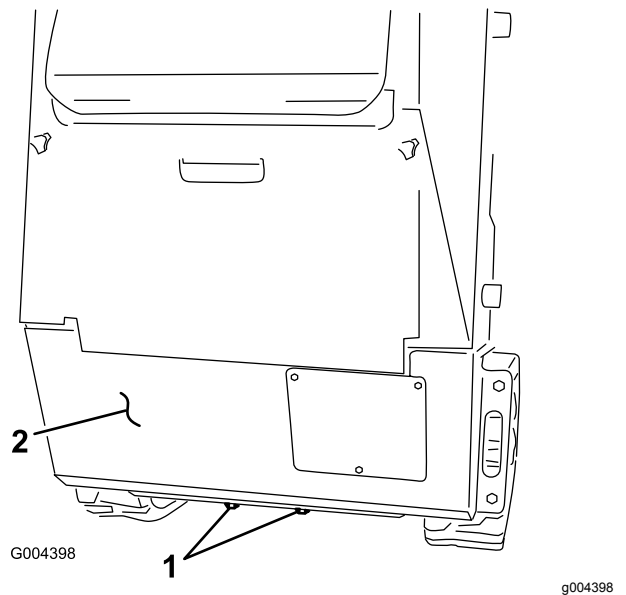

Figure 2

1. Bolts
2. Rear panel (do not remove)

2. One at a time, remove and discard the 4 bolts and nuts securing sides of the lower rear panel to the frame, replacing each with a new bolt (1/2 x 1-1/2 inches) installed from the front to hold the space as pressure is released on the rear panel (Figure 3).

Important: Do not remove the rear panel (Figure 2).

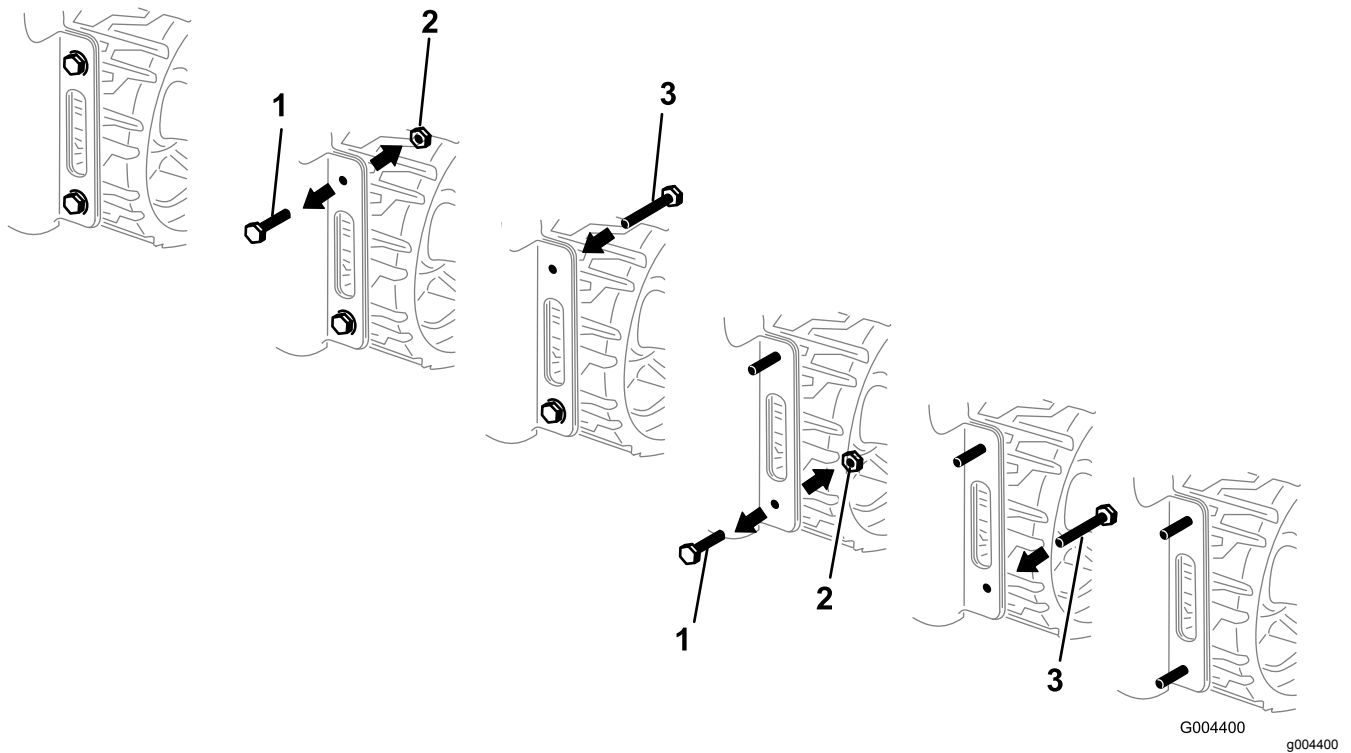

Figure 3
Left side not shown.

- | | | |
|--------------------------|-------------------------------------|------------------------------|
| 1. Bolt (2 on each side) | 2. Flange-head nut (2 on each side) | 3. Bolt (1/2 x 1-1/2 inches) |
|--------------------------|-------------------------------------|------------------------------|

Note: Figure 3 shows a TX 500 series traction unit. If you have a TX 400 series traction unit it will look slightly different, but it is configured similarly.

- Grab the platform handle and pull up on it to extend the platform (Figure 4).

- Install the mounting brackets (Figure 5) onto the 4 bolts (1/2 x 1-1/2 inches) you inserted earlier, and secure them with 4 flange-head nuts (1/2 inch).

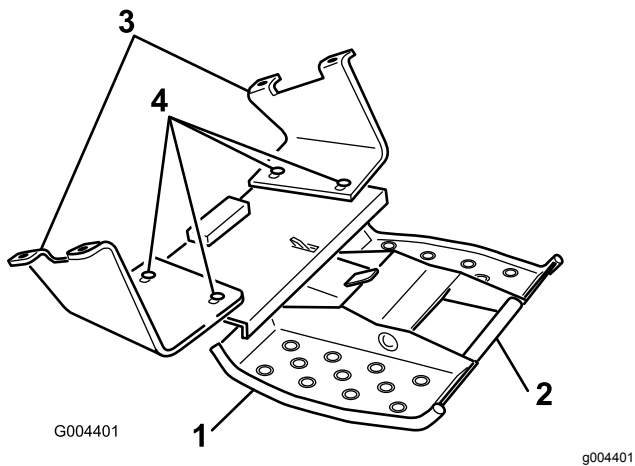

Figure 4

- | | |
|----------------------|-----------------------|
| 1. Platform assembly | 3. Mounting bracket |
| 2. Handle | 4. Loosen these bolts |

- By hand, loosen, but do not remove, the 4 bolts and nuts securing the platform assembly to the mounting brackets (Figure 4).

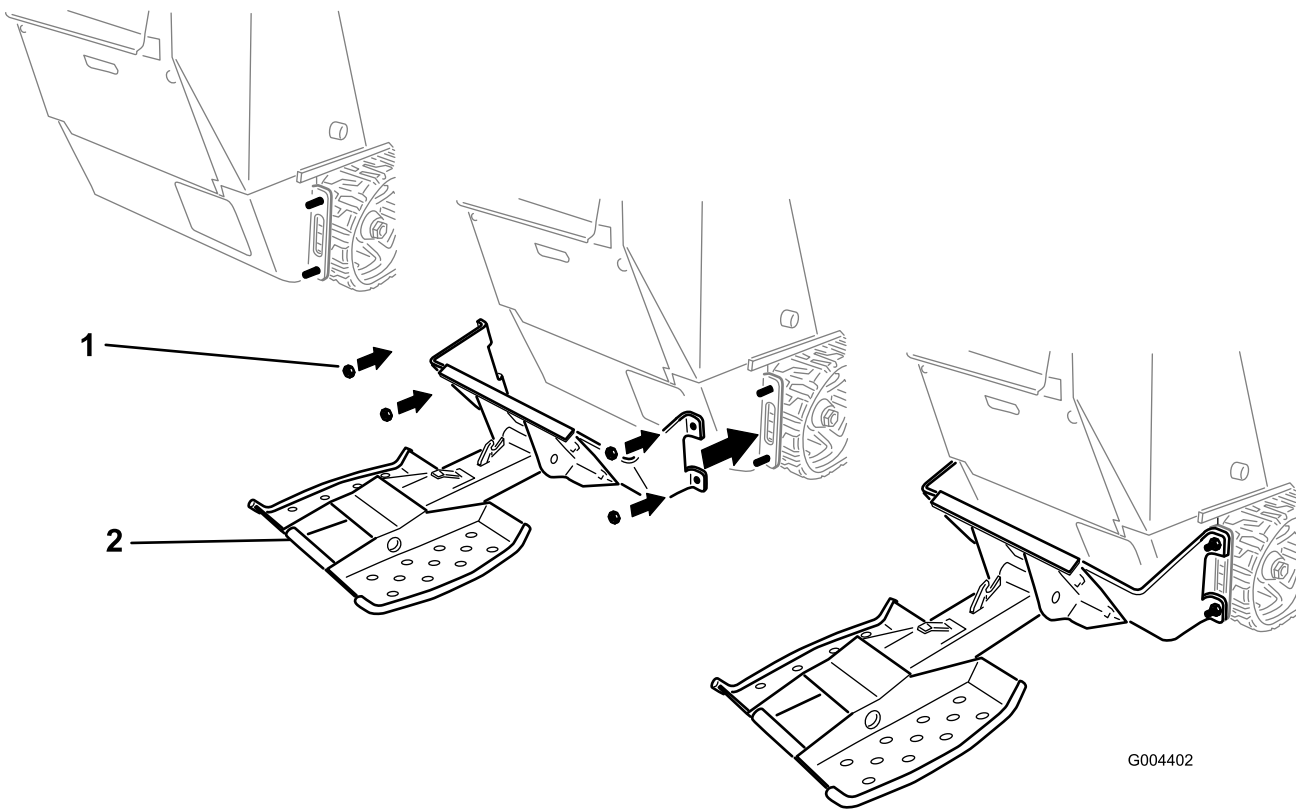

Figure 5

1. Flange-head nut (1/2 inch) 2. Platform

-
6. Torque the flange-nuts to 91 to 113 N·m (67 to 83 ft-lb).
7. Align the platform so that it is centered on the machine ([Figure 4](#)), then torque the 4 bolts and nuts securing the platform assembly to the mounting brackets to 91 to 113 N·m (67 to 83 ft-lb).

3

Installing the Counterweight (TX 500 Series Traction Units Only)

Parts needed for this procedure:

1	Counterweight
4	Bolt (1/2 x 1-1/4 inches)
4	Washer

Procedure

If you are installing this kit on a TX 500 series traction unit, install the counterweight to the front of the traction unit using 4 bolts (1/2 x 1-1/4 inches) and washers (Figure 6). Apply a locking compound to the threads of the bolts before installing them. Torque the bolts to 73 to 89 N·m (54 to 66 ft-lb).

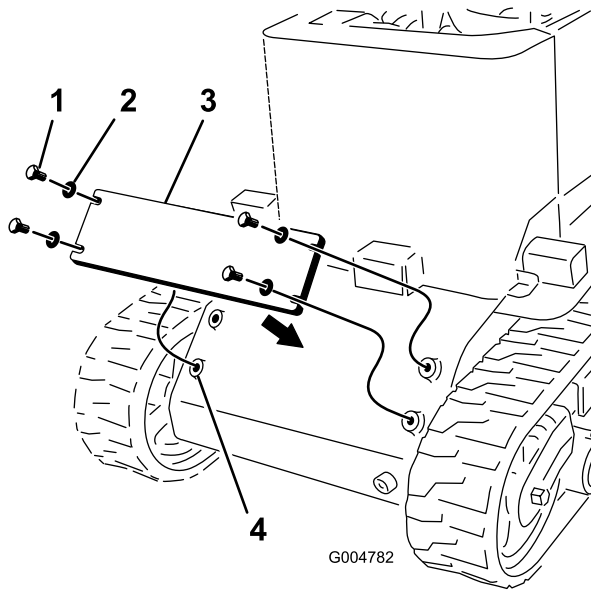

Figure 6

1. Bolt (1/2 x 1-1/4 inches)
2. Washer
3. Counterweight
4. Mounting holes

4

Installing the Decal

No Parts Required

Procedure

1. Clean the area behind the traction control (Figure 7) so that there is not dirt or grease on it.

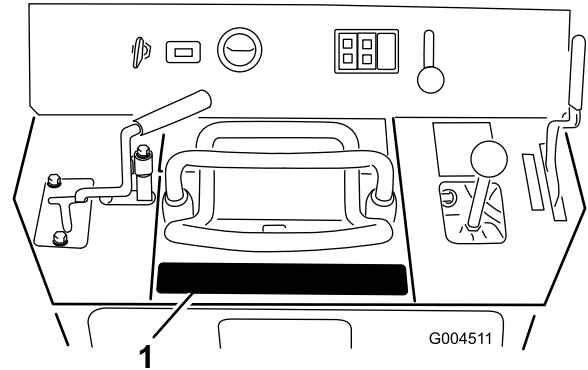

Figure 7

1. Decal position

2. Remove the backing from the decal and secure it in place (Figure 7).

Note: To keep from getting bubbles under the decal, press it down in the center first and rub it outward toward the edges.

5

Installing the Handle

Parts needed for this procedure:

1	Handle
2	Flange-head bolts (5/16 x 3/4 inch)

Procedure

1. Remove the rear access cover; refer to your traction unit *Operator's Manual* for instructions.
2. Locate and drill 2 holes—9.5 mm (3/8 inch diameter) on the control panel below the loader arm lever, as shown in [Figure 8](#).

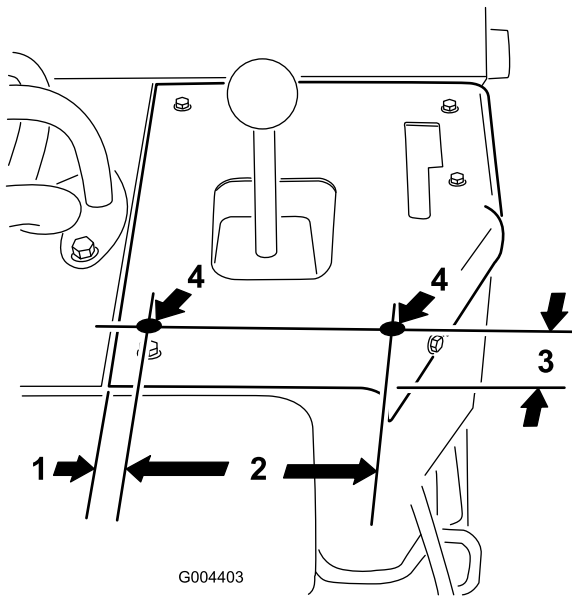

Figure 8

1. 22 mm (55/64 inch)
2. 146 mm (5-3/4 inches)
3. 51 mm (2 inches)
4. Drill—9.5 mm (3/8 inch) diameter holes

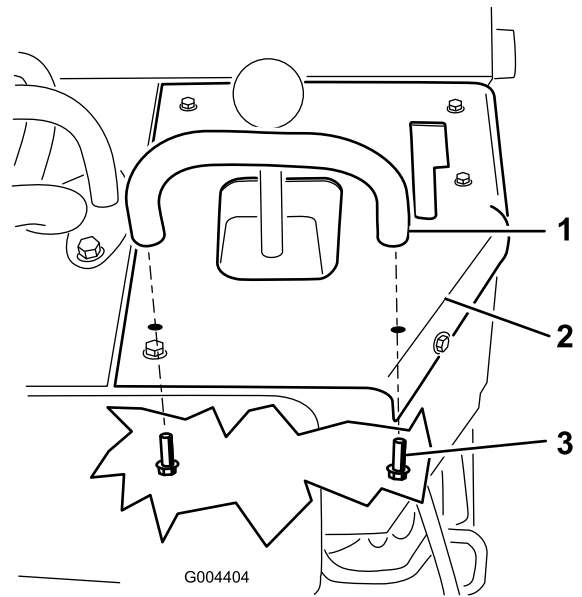

Figure 9

1. Handle
 2. Control panel
 3. Flange-head bolt (5/16 x 3/4 inch)
-
4. Install the rear access cover.

Operation

⚠ WARNING

If you step off of the platform with a heavy load raised, the machine could tip forward quickly, injuring your and/or pinning bystanders.

Do not step off of the platform with the load raised.

⚠ WARNING

Unless you are carrying heavy loads or attachments, the platform with an operator will make the rear of the machine the heavy end.

Always keep the heavy end of the machine uphill when operating on slopes.

⚠ WARNING

You could fall off of the platform and be seriously injured during operation.

Do not move the controls unless you are standing with both feet on the platform and your hands are holding the handles.

Folding/Unfolding the Platform

To fold the platform, lift up on the back of it and swing it towards the traction unit (Figure 10). When the latch contacts the mounting plate, the platform will slide down into the tube and will lock in place.

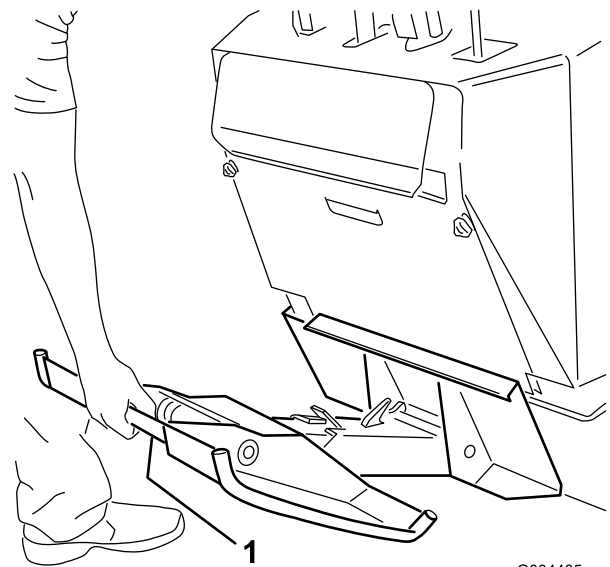

G004405
g004405

Figure 10

1. Handle

To unfold the platform, pull up on it until the latch releases and then swing it out and down (Figure 11).

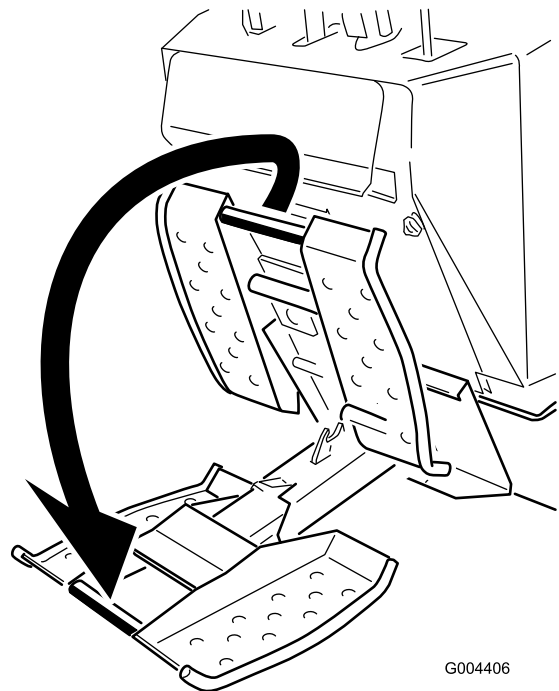

G004406

g004406

Figure 11

Using the Platform

To use the platform, step onto it before starting the machine. Fully stop the machine and apply the parking brake before getting off of the platform. Use the reference bar and handle to stabilize yourself while riding on the platform.

Maintenance

Greasing the Platform

Grease all pivot joints every 8 operating hours and immediately after every washing.

Grease Type: General-purpose grease.

1. Lower the loader arms and stop the engine. Remove the key.
2. Clean the grease fittings with a rag.
3. Connect a grease gun to each fitting (Figure 12).

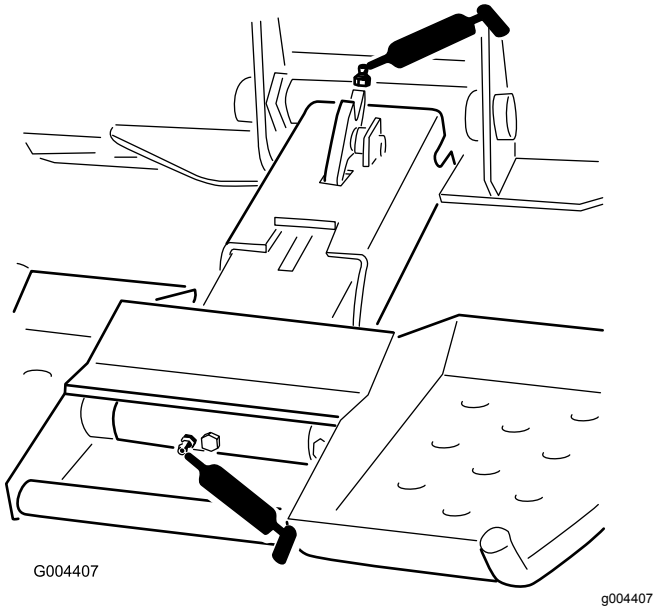

Figure 12

Checking the Shear Bolt

Check the shear bolt (Figure 13) for wear, cracks, or damage every 8 operating hours. Replace it if it is damaged.

Important: Use only a genuine Toro replacement shear bolt and nut. Other bolts will not function correctly and may lead to an unsafe condition.

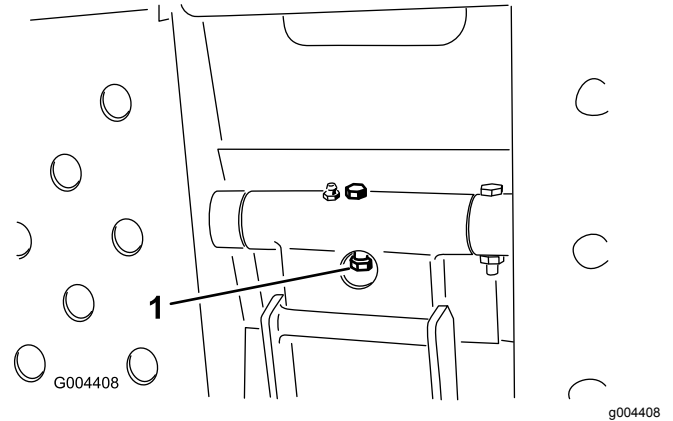

Figure 13

1. Shear bolt

4. Pump grease into the fittings until grease begins to ooze out (approximately 3 pumps).
5. Wipe up any excess grease.

Notes:

Notes:



The Toro Compact Utility Loader Product Line Warranty

A One-Year Limited Warranty

Conditions and Products Covered

The Toro® Company and its affiliate, Toro Warranty Company, pursuant to an agreement between them, jointly warrant your Toro Dingo Product ("Product") to be free from defects in materials or workmanship. The following time periods apply from the date the Product is delivered to the original retail purchaser:

Products	Warranty Period
All traction units and attachments	1 year or 1000 operating hours, whichever occurs first
All Engines	2 years

Where a warrantable condition exists, we will repair the Product at no cost to you including diagnosis, labor, and parts.

Instructions for Obtaining Warranty Service

If you think that your Toro Product contains a defect in materials or workmanship, follow this procedure:

1. Contact any Authorized Dingo Service Dealer to arrange service at their dealership. To locate a dealer convenient to you, access our website at www.Toro.com. U.S. Customers may also call 800-348-2424.
2. Bring the product and your proof of purchase (sales receipt) to the Service Dealer.

If for any reason you are dissatisfied with the Service Dealer's analysis or with the assistance provided, contact us at:

LCB Customer Care Department
Toro Warranty Company
8111 Lyndale Avenue South
Bloomington, MN 55420-1196
Toll Free: 888-577-7466 (U.S. customers)
Toll Free: 877-484-9255 (Canada customers)

Owner Responsibilities

You must maintain your Toro Product by following the maintenance procedures described in the *Operator's Manual*. Such routine maintenance, whether performed by a dealer or by you, is at your expense. Parts scheduled for replacement as required maintenance ("Maintenance Parts"), are warranted for the period of time up to the scheduled replacement time for that part. Failure to perform required maintenance and adjustments can be grounds for disallowing a warranty claim.

Items and Conditions Not Covered

Not all product failures or malfunctions that occur during the warranty period are defects in materials or workmanship. This express warranty does not cover the following:

- Product failures which result from the use of non-Toro replacement parts, or from installation and use of add-on, modified, or unapproved accessories
- Product failures which result from failure to perform required maintenance and/or adjustments
- Product failures which result from operating the Product in an abusive, negligent or reckless manner
- Parts subject to consumption through use unless found to be defective. Examples of parts which are consumed, or used up, during normal Product operation include, but are not limited to, digging teeth, tines, spark plugs, tires, tracks, filters, chains, etc.
- Failures caused by outside influence. Items considered to be outside influence include, but are not limited to, weather, storage practices, contamination, use of unapproved coolants, lubricants, additives, or chemicals, etc.
- Normal "wear and tear" items. Normal "wear and tear" includes, but is not limited to, worn painted surfaces, scratched decals or windows, etc.
- Any component covered by a separate manufacturer's warranty
- Pickup and delivery charges

General Conditions

Repair by an Authorized Toro Service Dealer is your sole remedy under this warranty.

Neither The Toro® Company nor Toro Warranty Company is liable for indirect, incidental or consequential damages in connection with the use of the Toro Products covered by this warranty, including any cost or expense of providing substitute equipment or service during reasonable periods of malfunction or non-use pending completion of repairs under this warranty.

Some states do not allow exclusions of incidental or consequential damages, or limitations on how long an implied warranty lasts, so the above exclusions and limitations may not apply to you.

This warranty gives you specific legal rights, and you may also have other rights which vary from state to state.

Except for the Emissions warranty referenced below, if applicable, there is no other express warranty. All implied warranties of merchantability and fitness for use are limited to the duration of this express warranty.

Note to California residents: The Emissions Control System on your Product may be covered by a separate warranty meeting requirements established by the U.S. Environmental Protection Agency (EPA) or the California Air Resources Board (CARB). The hour limitations set forth above do not apply to the Emissions Control System Warranty. Refer to the California Emission Control Warranty Statement printed in your operator's manual or contained in the engine manufacturer's documentation for details. Countries

Countries Other than the United States or Canada

Customers who have purchased Toro products exported from the United States or Canada should contact their Toro Distributor (Dealer) to obtain guarantee policies for your country, province, or state. If for any reason you are dissatisfied with your Distributor's service or have difficulty obtaining guarantee information, contact the Toro importer. If all other remedies fail, you may contact us at Toro Warranty Company.