



**Count on it.**

**Parts Catalog**

**53cm Mulching/Rear  
Bagging/Side Discharging  
Lawn Mower**

Model No. 21750—Serial No. 400000000 and Up



# Ordering Replacement Parts

To order replacement parts, please supply the part number, the quantity, and the description of each part desired.

## Understanding Reference Numbers

Each identified part in an illustration has a reference number. The reference number for a part also appears in the parts list, along with other information about the part.

This catalog uses two special reference number formats, one to indicate parts in a service assembly and another to indicate the quantity of a given part in an illustration.

## Service Assembly Reference Numbers

Parts in service assemblies have reference numbers in the form a:b. The a represents the reference number of the entire service assembly and the b represents a sequential number unique to each part within the service assembly.

For example, a wheel assembly might be identified by reference number 6, the tire by 6:1, the valve by 6:2, and the wheel by 6:3. When you order the assembly identified by reference number 6, you receive all parts identified by reference numbers 6:1, 6:2, and 6:3. However, you may also order any part individually. Reference numbers of this type appear in illustration and in parts lists.

## Reference Numbers Indicating Quantity

In an illustration, if a reference number indicates more than one part, the reference number has the form nX y. The n represents the quantity of the part, the X is the multiplication symbol, and the y represents the reference number.

For example, in an illustration, the reference number 2X 37 means that two of the parts identified by reference number 37 are indicated.

# Contents

Frame Assembly.....	4
Bag and Chute Assembly.....	6
Engine and Blade Assembly.....	8
Front Wheel and Height-of-Cut Assembly.....	10
Transmission and Rear Wheel Assembly.....	12
Handle Assembly.....	14
Attachments and Accessories.....	16

# Frame Assembly

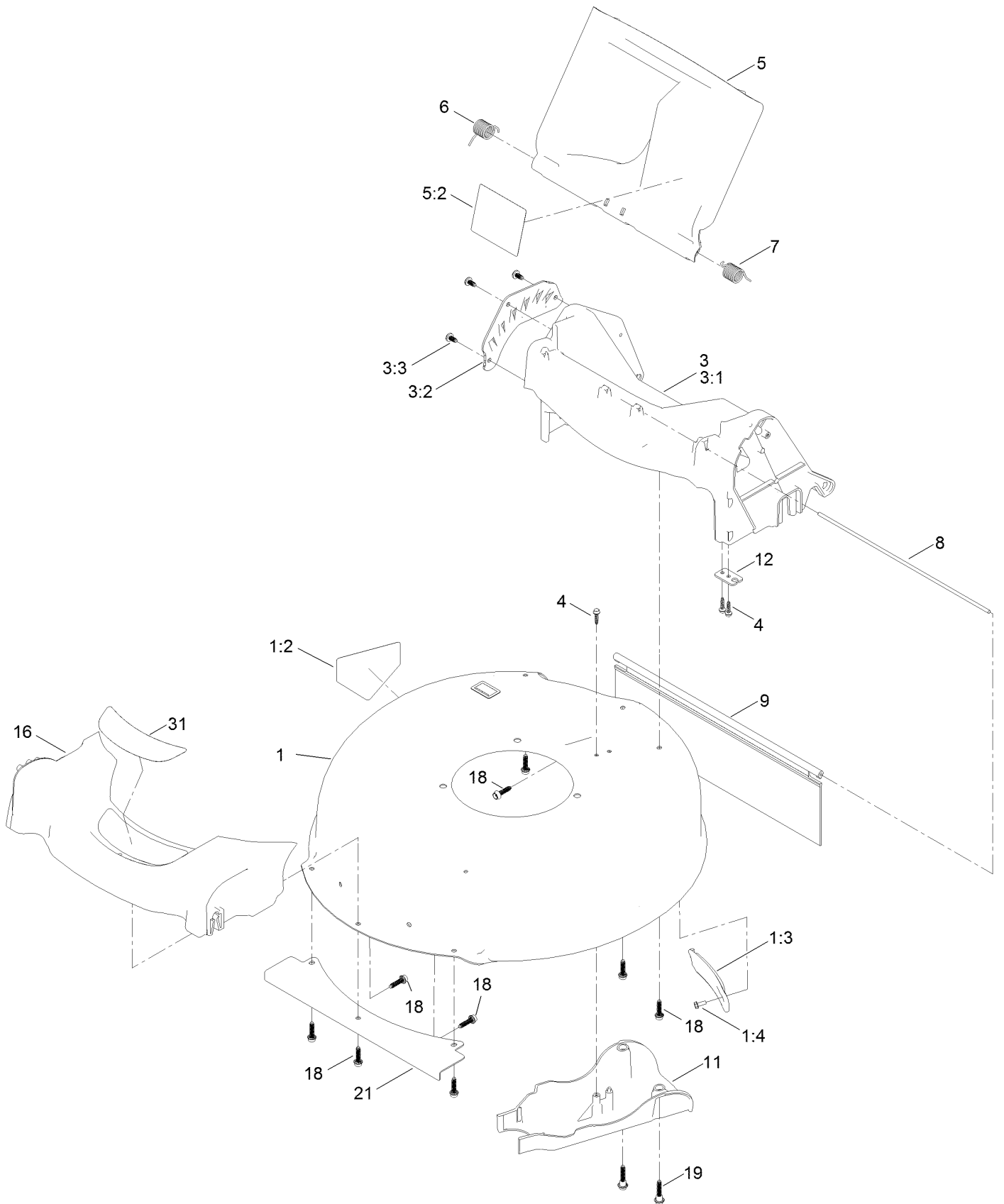

## Frame Assembly (continued)

<i>Ref.</i>	<i>Part Number</i>	<i>Qty.</i>	<i>Description</i>	<i>Ref.</i>	<i>Part Number</i>	<i>Qty.</i>	<i>Description</i>
1	133-1939	1	Housing ASM	6	127-6807	1	Spring-Torsion
1:2	112-8760	1	Decal-Danger	7	138-5378	1	Spring-Torsion
1:3	132-4518	1	Cover-Belt	8	127-0698	1	Rod-Door
1:4	32144-1	1	Screw-Taptite	9	127-0724	1	Shield-Trailing
3	139-1805	1	Chute ASM	11	127-0723	1	Cover-Belt
3:1	133-1912	1	Chute	12	127-0730	1	Bracket-Cable
3:2	133-1905-03	1	Plate-HOC	16	127-0677	1	Bumper
3:3	139-1679	3	Screw-Plastic,PH	18	130-6658	7	Screw-Flange, Plastic
4	139-1690	3	Screw-Plastic, HWH	19	131-0837	2	Screw-Shoulder, HHF
5	130-2368	1	Rear Deflector ASM	21	131-0820-03	1	Shield-Front
5:2	117-4143	1	Decal-Warning	31	130-6740	1	Decal-Deck

# Bag and Chute Assembly

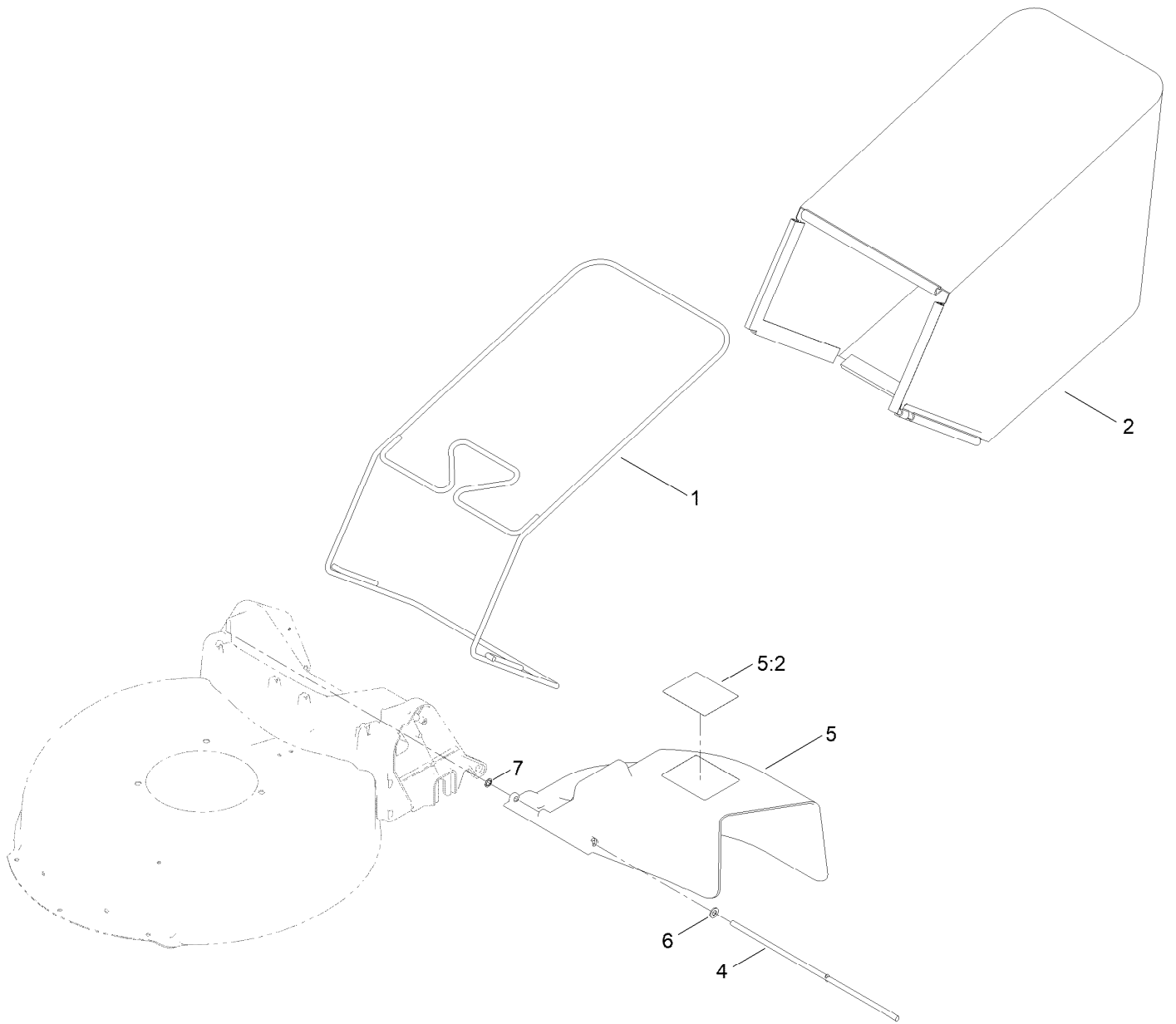

## Bag and Chute Assembly (continued)

<i>Ref.</i>	<i>Part Number</i>	<i>Qty.</i>	<i>Description</i>	<i>Ref.</i>	<i>Part Number</i>	<i>Qty.</i>	<i>Description</i>
1	131-9697-03	1	Frame-Bag	5:2	117-4143	1	Decal-Warning
2	130-6744	1	Bag-Grass	6	120-9683	1	Washer-Plain
4	138-5322	1	Rod	7	32151-72	1	Ring-Retaining
5	127-6806	1	Deflector-Chute				

# Engine and Blade Assembly

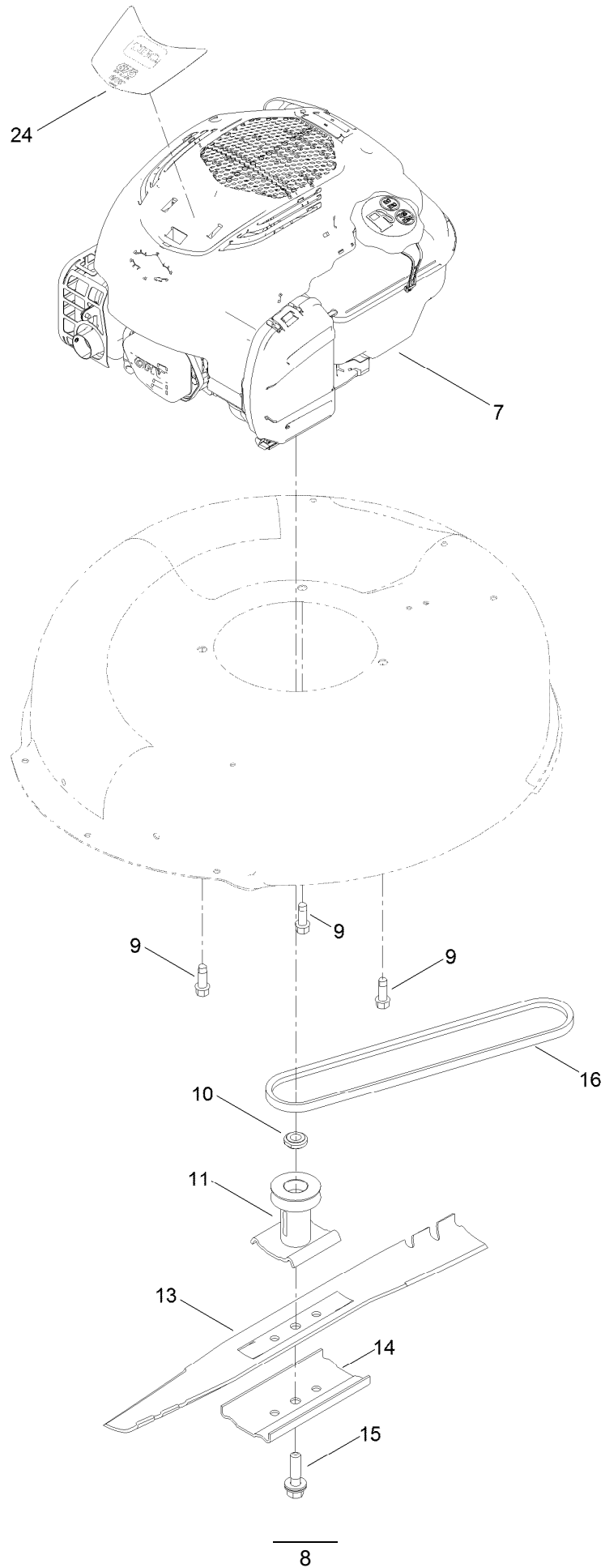



## Engine and Blade Assembly (continued)

<i>Ref.</i>	<i>Part Number</i>	<i>Qty.</i>	<i>Description</i>	<i>Ref.</i>	<i>Part Number</i>	<i>Qty.</i>	<i>Description</i>
7		1	Engine-Briggs 104M020043F1 ●■	13	133-8182-03	1	Blade-21In
9	95-1726	3	Screw-Taptite	14	108-3766-03	1	Support-Blade
10	106-3999	1	Spacer-Driver	15	125-2466	1	Bolt-Blade
11	106-3987	1	Driver-Blade	16	110-9429	1	V-Belt
				24	132-4472	1	Decal-Shroud

● Not serviced separately

■ Obtain parts from [www.briggsandstratton.com](http://www.briggsandstratton.com)

# Front Wheel and Height-of-Cut Assembly

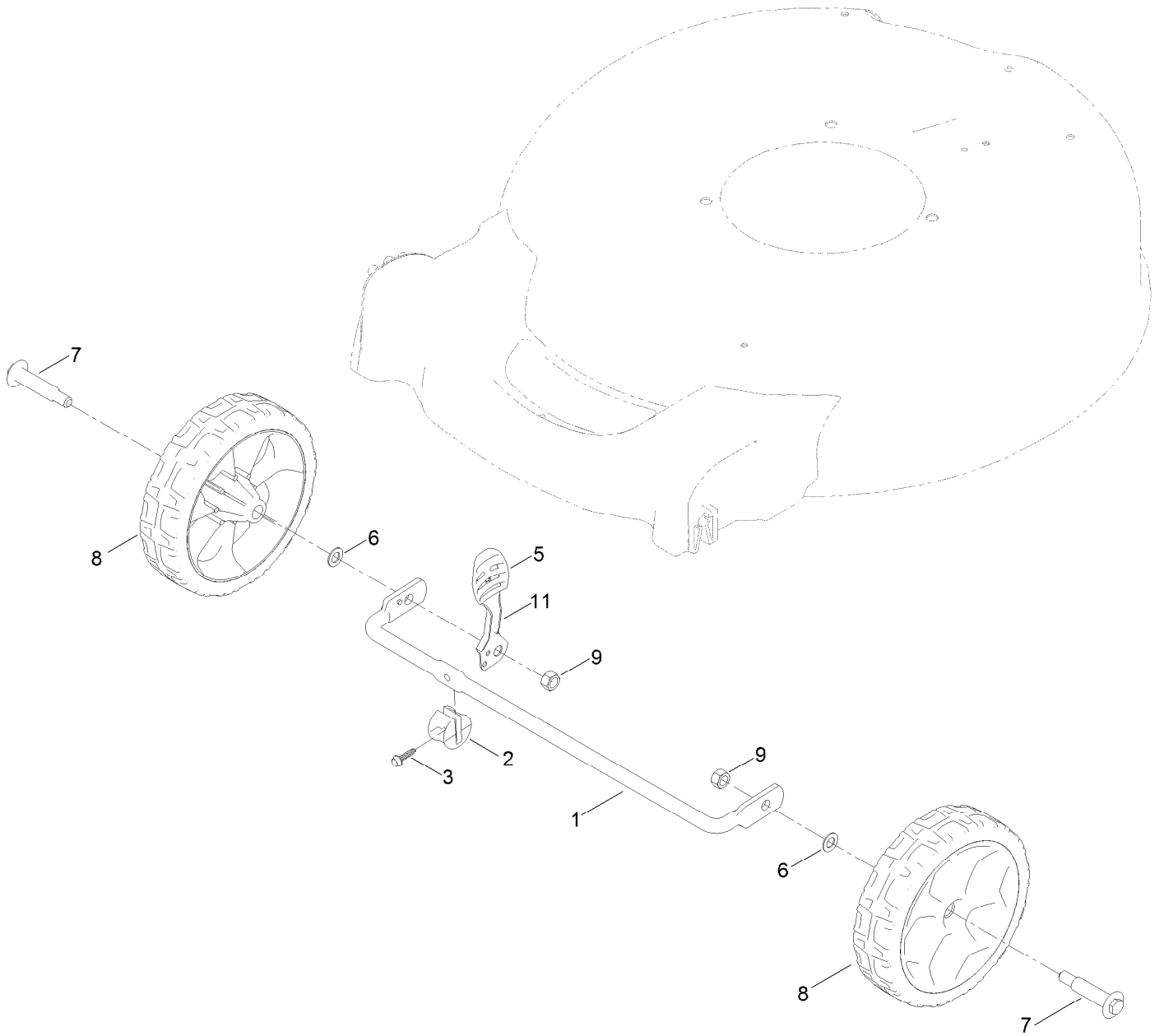

## Front Wheel and Height-of-Cut Assembly (continued)

<i>Ref.</i>	<i>Part Number</i>	<i>Qty.</i>	<i>Description</i>	<i>Ref.</i>	<i>Part Number</i>	<i>Qty.</i>	<i>Description</i>
1	127-0668-03	1	Axle-Front	7	92-1057	2	Bolt-Shoulder
2	127-6800	1	Stop-Axle	8	127-0683	2	7 Inch Wheel ASM
3	139-1690	1	Screw-Plastic, HWH	9	603773	2	Locknut
5	105-3042	1	Knob-Lever, HOC	11	133-8154	1	Arm-Spring
6	40-1940	2	Washer				

# Transmission and Rear Wheel Assembly

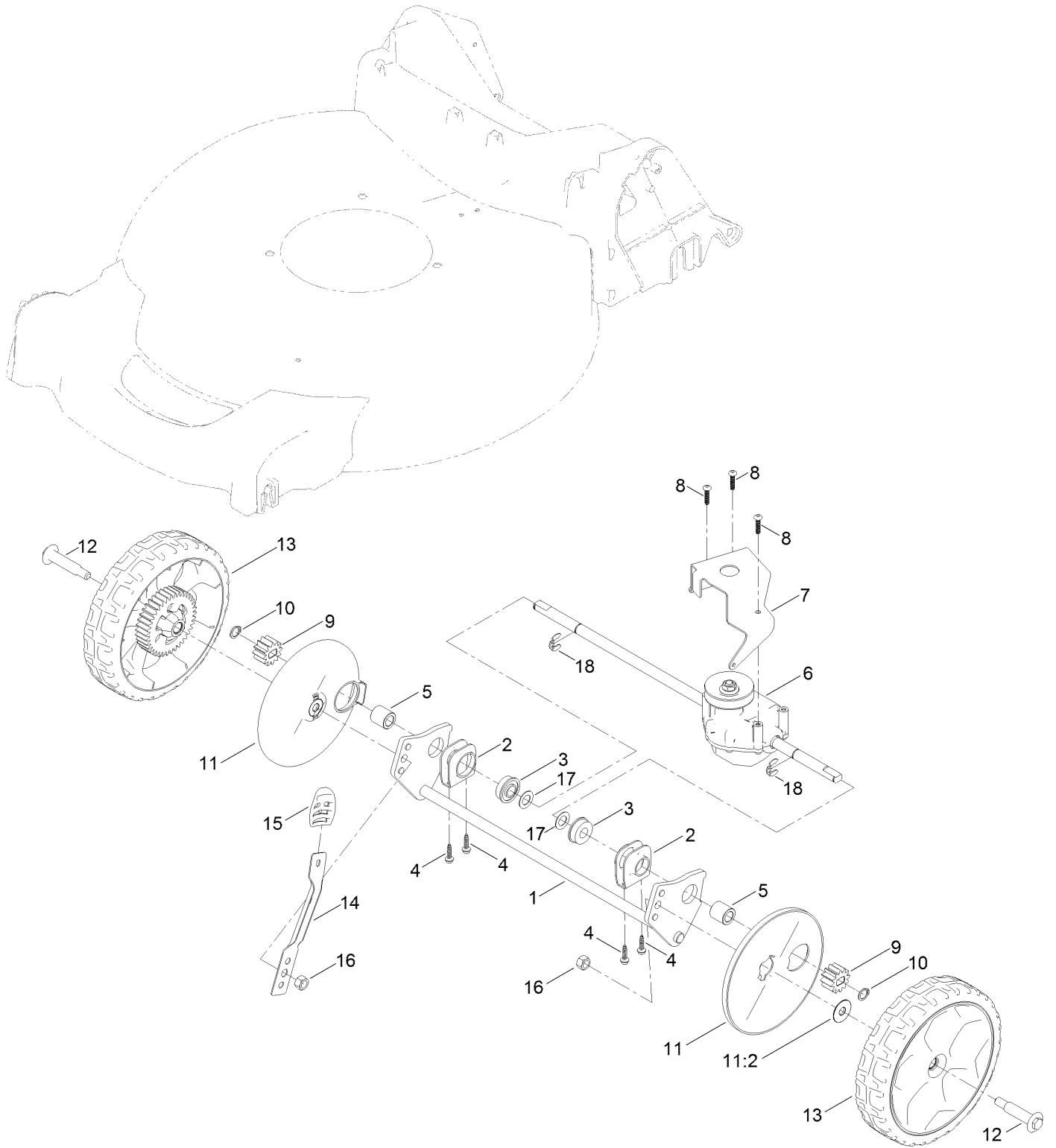

## Transmission and Rear Wheel Assembly (continued)

<i>Ref.</i>	<i>Part Number</i>	<i>Qty.</i>	<i>Description</i>	<i>Ref.</i>	<i>Part Number</i>	<i>Qty.</i>	<i>Description</i>
1	127-0708-03	1	Axle-Rear	11	127-6840	2	Wheel Cover ASM
2	138-3234	2	Retainer-Bearing	11:2	614426	1	Washer-Stepped
3	104-8699	2	Bearing-Ball	12	92-1057	2	Bolt-Shoulder
4	139-1690	4	Screw-Plastic, HWH	13	127-0692	2	8 Inch Wheel Gear ASM
5	127-6896	2	Bushing-Sleeve	14	127-0711	1	Arm-Spring
6	131-0881	1	Transmission	15	105-3042	1	Knob-Lever, HOC
7	114-7977-03	1	Bracket-Transmission	16	603773	2	Locknut
8	120-9676	3	Screw-Plastite	17	36-4780	2	Washer-Plain
9	115-4668	2	Gear-Pinion	18	65-2720	2	Ring-Retaining, Clip
10	32151-61	2	Ring-Retaining				

# Handle Assembly

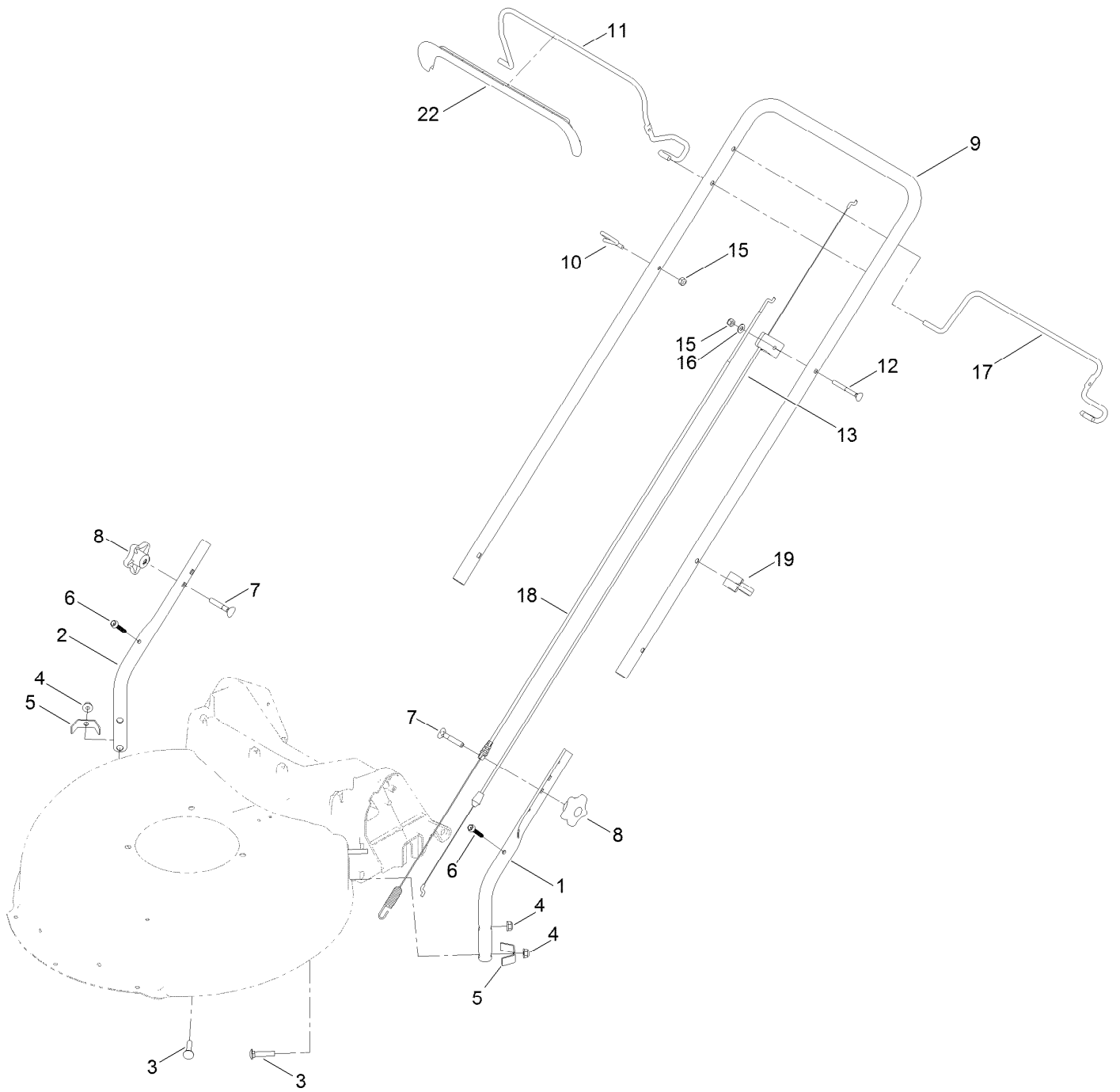

## Handle Assembly (continued)

<i>Ref.</i>	<i>Part Number</i>	<i>Qty.</i>	<i>Description</i>	<i>Ref.</i>	<i>Part Number</i>	<i>Qty.</i>	<i>Description</i>
1	136-5923-05	1	Handle-Lower, LH	11	138-3270-03	1	Bail-Brake
2	136-5924-05	1	Handle-Lower, RH	12	139-1701	1	Screw-Handle
3	139-1707	4	Screw-CARR	13	112-8818	1	Cable-Brake
4	138-8401	4	Nut-HF	15	137-3094	2	Nut-Hex
5	127-0699	2	Bracket-Chute	16	139-1699	1	Washer-Flat
6	130-6659	2	Screw-Flange, Serrated	17	137-4799-03	1	Bail-Traction
7	137-3107	2	Screw-Handle	18	127-0733	1	Cable-Traction
8	117-5976	2	Knob-Handle	19	114-7988	1	Guide-Cable
9	137-4826-05	1	Handle-Upper	22	137-4797	1	Cover-Bail
10	86-9671	1	Guide-Rope				

# Attachments and Accessories

## For 21750 53cm Mulching/Rear Bagging/Side Discharging Lawn Mower

<b>Product Name</b>	<b>Model/Part</b>
4-Cycle Fuel, Snow And Lawn 32oz Can .....	131-3823
Toro Premium Fuel Treatment 12 Oz Bottle .....	131-6572
Side-Discharge Deflector, 2013 and After 21in Steel Deck Mower .....	136-7060
Oil-30/10W-30 Synthetic (Quart).....	138-6053
Toro 4-Cycle SAE 30 Oil (32oz Bottle) .....	38903
Summer Oil-Case of 24 (20oz Bottles).....	38916
Bag-Walk Behind (Toro).....	490-7318



**Notes:**

**Notes:**

**Notes:**



**Count on it.**