



ROPS Kit
TimeCutter® Riding Mower
Model No. 79485

Installation Instructions

Safety

Rollover Protection System (ROPS) Safety

- The ROPS is an integral safety device. Do not remove any of the ROPS components from the machine.
- Ensure that the seat belt is attached and that you can release it quickly in an emergency.
- Always wear your seat belt when the roll bar is installed.
- Check carefully for overhead objects before you drive under them, and do not contact them.
- Keep the roll bar in safe operating condition by thoroughly inspecting it periodically for damage and keeping all the mounting fasteners tight.
- Replace damaged ROPS components. Do not repair or alter them.
- Wheels dropping over edges, over steep banks, or into water can cause a rollover, which may result in serious injury or death.
- Do not wear the seat belt when the roll bar is not installed.
- In the event of a rollover, take the machine to an Authorized Service Dealer to inspect the ROPS.
- Use only Toro approved accessories and attachments for the ROPS.



Installation

Loose Parts

Use the chart below to verify that all parts have been shipped.

Procedure	Description	Qty.	Use
1	No parts required	–	Prepare the machine.
2	Left ROPS mount Right ROPS mount Bolt (1/2 x 1-1/4 inches) Large washer Locknut (1/2 inch) Belt guard panel Rear guard panel Cable tie Narrow push rivet Wide push rivet	1 1 6 6 6 2 1 2 4 2	Install the ROPS mounts and guard panels.
3	Left seat belt bracket (MyRide machines only) Right seat belt bracket (MyRide machines only) Partial-thread bolt (3/8 x 2 inches) Small washer Locknut (3/8 inch) Left pod bracket Bumper Right pod bracket (MyRide machines only) Thread-forming screw (5/16 x 3/4 inch) Seat belt tongue assembly Seat belt buckle assembly Carriage screw (7/16 x 1 inch) Locknut (7/16 inch)	1 1 2 2 2 1 1 1 1 3 1 1 2 2	Install the pod brackets and seat belt brackets (MyRide-equipped machines only).
4	Seat belt tongue assembly Seat belt buckle assembly Carriage screw (7/16 x 1 inch) Locknut (7/16 inch) Seat belt bracket (machines without MyRide only) Bolt (3/8 x 1 inch) Locknut (3/8 inch) Left pod bracket Bumper Right pod bracket (machines without MyRide only) Thread-forming screw (5/16 x 3/4 inch)	1 1 2 2 2 4 4 1 1 1 1 4	Install the pod brackets and seat belt brackets (machines without MyRide only).
5	ROPS tube Bolt (3/8 x 2-1/2 inches) Locknut (3/8 inch) Suitcase weight (For machines with a bagger installed only) Bolt (3/8 x 3-3/4 inches)	1 2 2 4 2	Complete the installation.

1

Preparing the Machine

No Parts Required

Procedure

Note: Determine the left and right sides of the machine from the normal operating position.

Note: You may discard all removed parts unless otherwise noted.

1. Park the machine on a level surface.
2. Disengage the blade-control switch.
3. Move the motion-control levers outward to the NEUTRAL-LOCK position to engage the parking brake.
4. Shut off the engine and remove the key.
5. Raise the seat, refer to your machine *Operator's Manual*.
6. Raise the rear of the machine on jack stands; refer to your machine *Operator's Manual*.

⚠ WARNING

Supporting the machine on the lower muffler shield (**Figure 1**) may damage the shield and cause the machine to fall, injuring you or bystanders.

Do not use the lower muffler shield to support the machine.

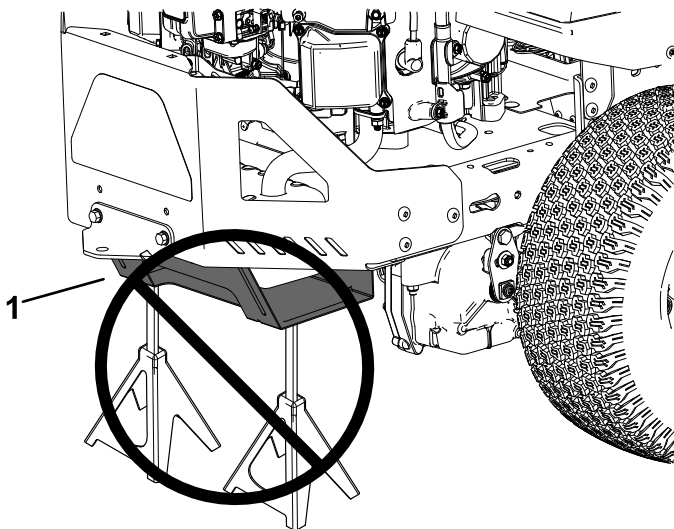

Figure 1

g299647

1. Lower muffler shield

7. Remove the rear tires as shown in **Figure 2**

Note: Retain all wheel components for later installation.

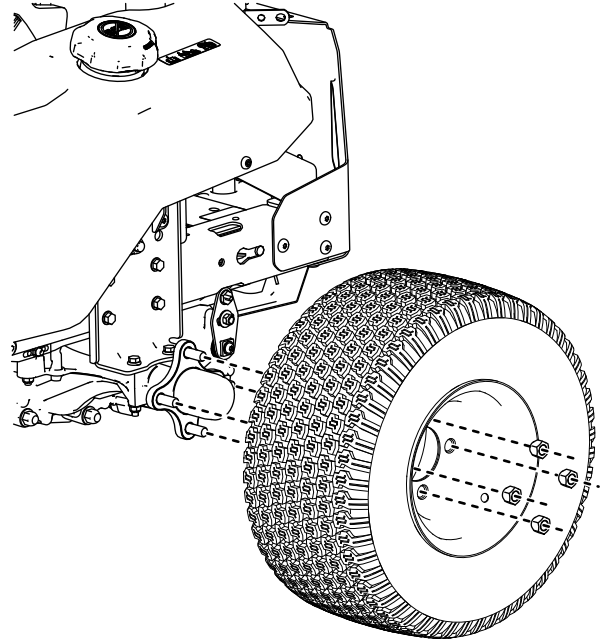
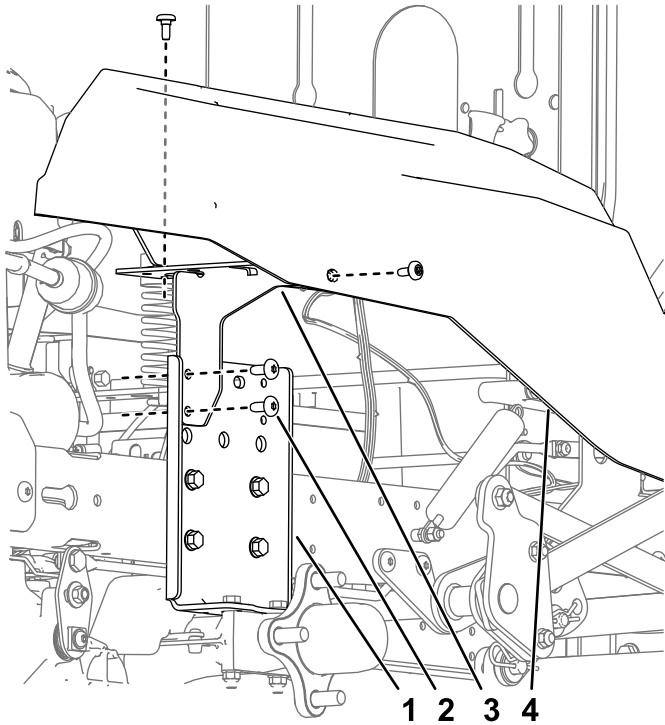

Figure 2

g309984

8. Remove the pod brackets from the machine (Figure 3).

Note: Retain the shoulder screws removed from the sides of the pods for later installation.



g310040

Figure 3

- | | |
|--------------------------|------------------------|
| 1. Hydraulic mount plate | 3. Pod support bracket |
| 2. Screw | 4. Pod |

Note: Retain the fuel tank spring beneath that secures the fuel tank to the left pod bracket for later installation.

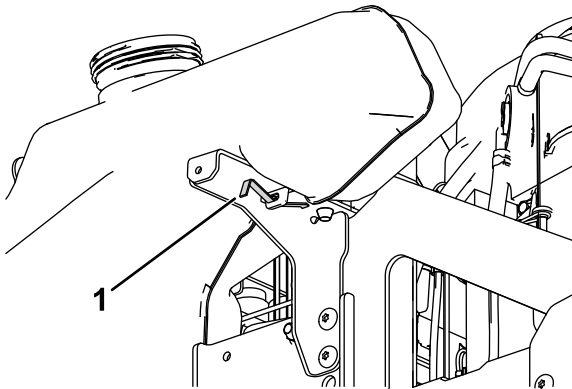

g310231

Figure 4

1. Fuel tank spring

2

Installing the ROPS Mounts and Guard Panels

Parts needed for this procedure:

1	Left ROPS mount
1	Right ROPS mount
6	Bolt (1/2 x 1-1/4 inches)
6	Large washer
6	Locknut (1/2 inch)
2	Belt guard panel
1	Rear guard panel
2	Cable tie
4	Narrow push rivet
2	Wide push rivet

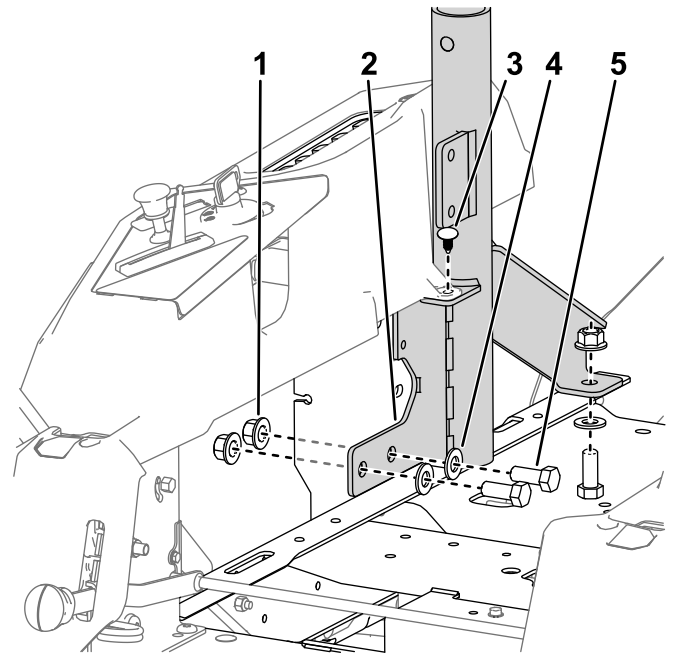

g316031

Figure 5

Right side shown

1. Locknut (1/2 inch)
2. Right ROPS mount
3. Narrow push rivet
4. Large washer
5. Bolt (1/2 x 1-1/4 inches)

Procedure

1. Install the ROPS mounts to the machine frame behind the hydraulic mount plate as shown in [Figure 5](#).
2. Torque the bolts to 58 to 77 N·m (43 to 57 ft-lb).
3. Secure the tabs on the pods to the ROPS mount with narrow push rivets ([Figure 5](#)).
4. Install the teeth of the rear guard panel to the notches in the center frame and secure it with cable ties as shown in [Figure 6](#).
5. Install the belt guard panels to the frame with push rivets as shown in [Figure 6](#).

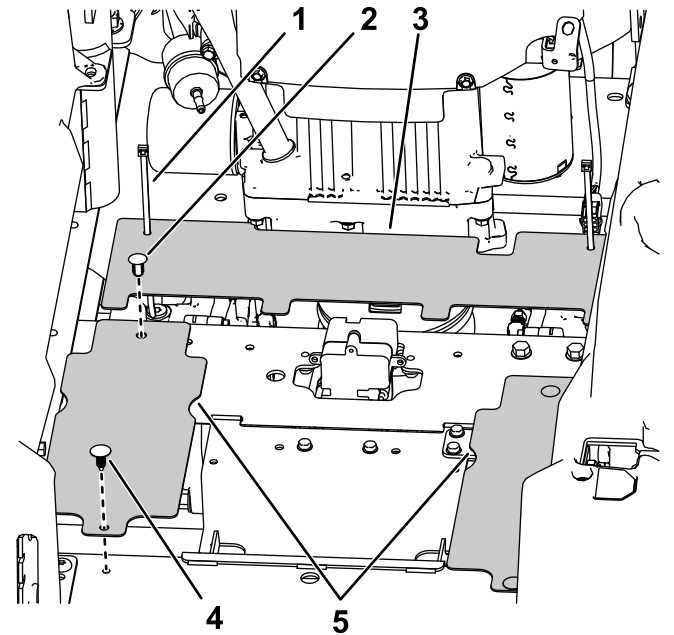

g310120

Figure 6

1. Cable tie
2. Wide push rivet
3. Rear guard panel
4. Narrow push rivet
5. Belt guard panels

3

Installing the Pod Brackets and Seat Belt

MyRide-Equipped Machines Only

Parts needed for this procedure:

1	Left seat belt bracket (MyRide machines only)
1	Right seat belt bracket (MyRide machines only)
2	Partial-thread bolt (3/8 x 2 inches)
2	Small washer
2	Locknut (3/8 inch)
1	Left pod bracket
1	Bumper
1	Right pod bracket (MyRide machines only)
3	Thread-forming screw (5/16 x 3/4 inch)
1	Seat belt tongue assembly
1	Seat belt buckle assembly
2	Carriage screw (7/16 x 1 inch)
2	Locknut (7/16 inch)

Procedure

1. Install the seat belt brackets to the seat platform with 2 partial-thread bolts (3/8 x 2 inches), 2 small washers, and 2 locknuts (3/8 inch) as shown in [Figure 7](#).

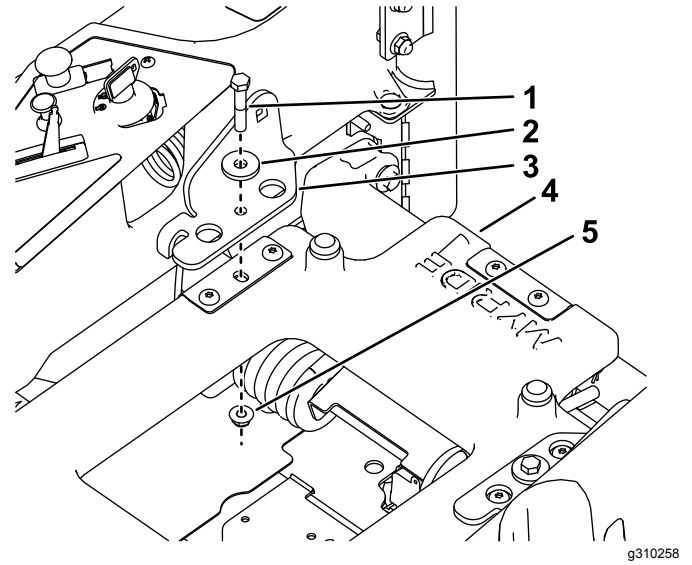

Figure 7

1. Partial-thread bolts (3/8 x 2 inches)
2. Small washer
3. Seat belt bracket
4. MyRide platform
5. Locknut (3/8 inch)

2. Install the bumper to the left pod bracket ([Figure 8](#)).

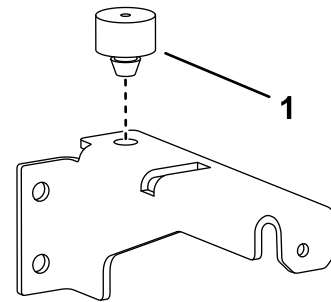

Figure 8

1. Bumper

3. Install the left pod bracket to the machine frame using 2 thread-forming screws (5/16 x 3/4 inch) and the parts removed in [1 Preparing the Machine \(page 3\)](#) as shown in [Figure 9](#).

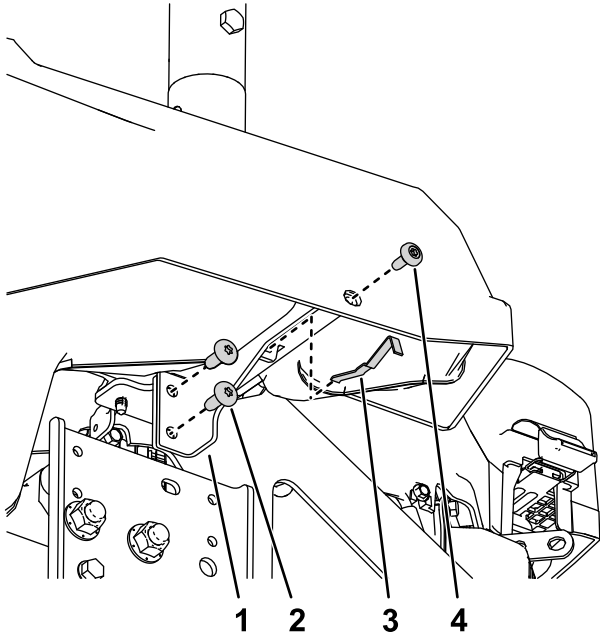

Figure 9

g310244

1. Left pod bracket
2. Thread-forming screw (5/16 x 3/4 inch)
3. Fuel-tank spring
4. Shoulder bolt

4. Install new right pod bracket to the machine using a thread-forming screw (5/16 x 3/4 inch) and the shoulder bolt removed in [1 Preparing the Machine \(page 3\)](#).

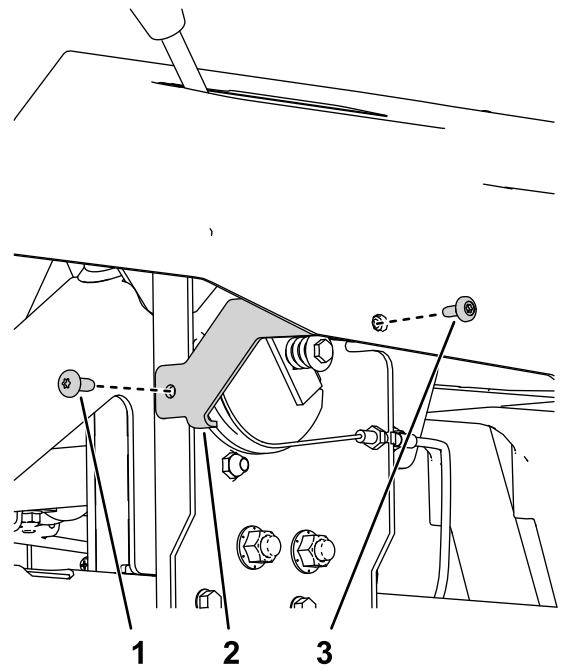

Figure 10

g310256

1. Thread-forming screw (5/16 x 3/4 inch)
2. Right pod bracket
3. Shoulder bolt

5. Install the seat belt buckle and tongue to the inside of the seat belt brackets with 2 carriage screws (7/16 x 1 inch) and 2 locknuts (7/16 inch) as shown in [Figure 11](#).

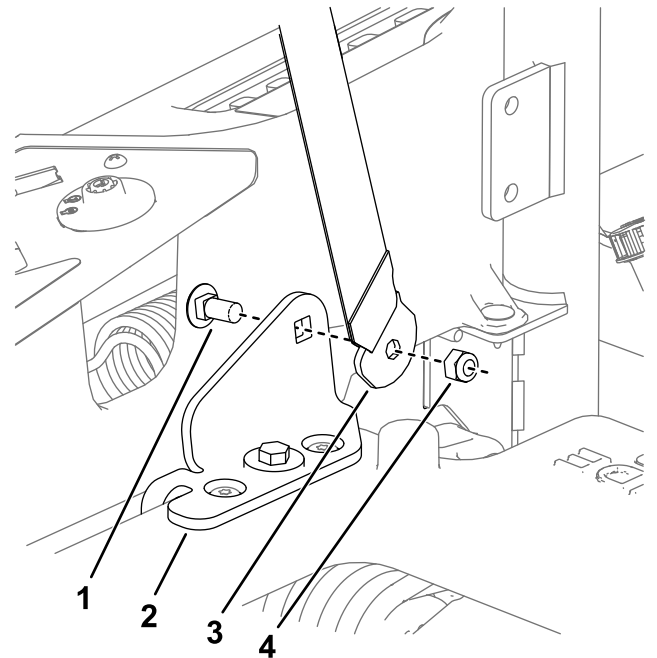

Figure 11

g316063

1. Carriage screws (7/16 x 1 inch)
2. Seat belt bracket
3. Seat belt tongue assembly (bracket bent toward the seat)
4. Locknut (7/16 x 1 inch)

4

Installing the Pod Brackets and Seat Belt

Machines without MyRide Only

Parts needed for this procedure:

1	Seat belt tongue assembly
1	Seat belt buckle assembly
2	Carriage screw (7/16 x 1 inch)
2	Locknut (7/16 inch)
2	Seat belt bracket (machines without MyRide only)
4	Bolt (3/8 x 1 inch)
4	Locknut (3/8 inch)
1	Left pod bracket
1	Bumper
1	Right pod bracket (machines without MyRide only)
4	Thread-forming screw (5/16 x 3/4 inch)

Procedure

1. Install the seat belt buckle and tongue to the inside of the seat belt brackets with 2 carriage screws (7/16 x 1 inch) and 2 locknuts (7/16 inch) as shown in [Figure 12](#).

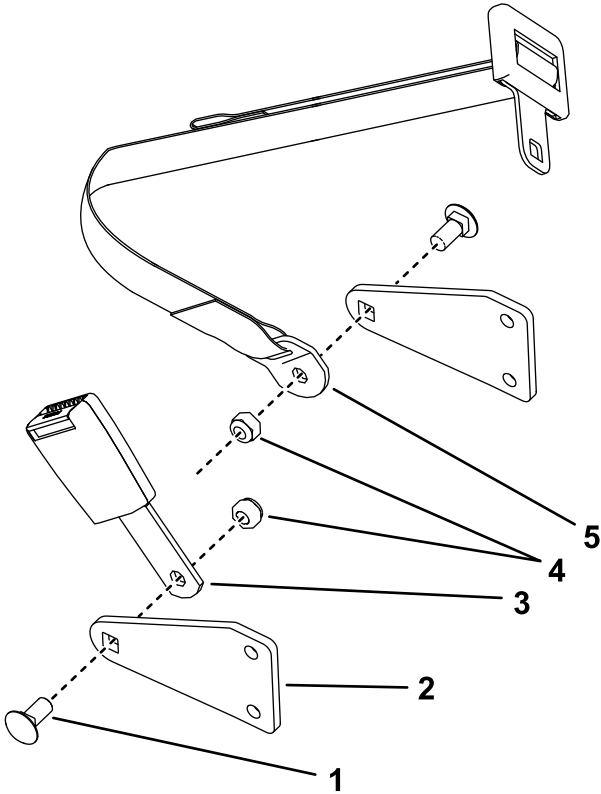

Figure 12

g316016

- | | |
|-----------------------------------|-------------------------|
| 1. Carriage screw (7/16 x 1 inch) | 4. Locknuts (7/16 inch) |
| 2. Seat belt bracket | 5. Tongue assembly |
| 3. Buckle | |

2. Install the seat belt brackets to the outside of the ROPS mounts (Figure 13).

Note: Install the seat belt buckle assembly with the bent bracket toward the seat.

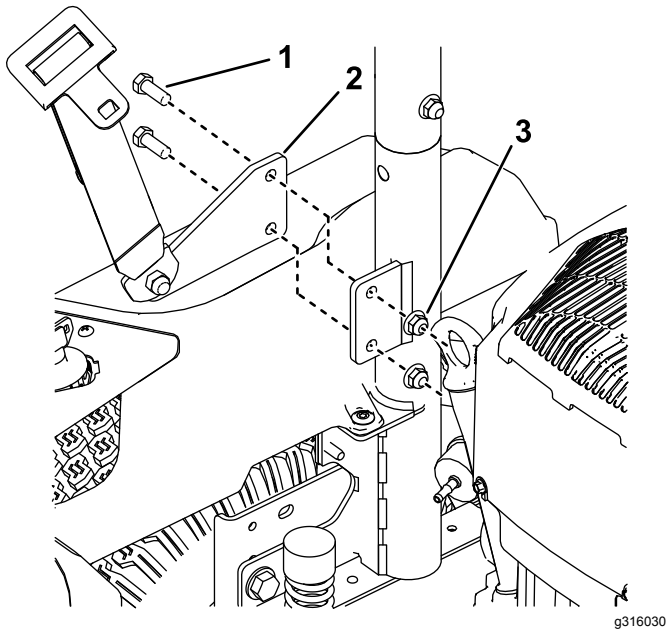

Figure 13

Right side shown

- | | |
|------------------------|-----------------------|
| 1. Bolt (3/8 x 1 inch) | 3. Locknut (3/8 inch) |
| 2. Seat belt bracket | |

5. Install the left pod bracket to the machine frame using 2 thread-forming screws (5/16 x 3/4 inch) as shown in Figure 13.

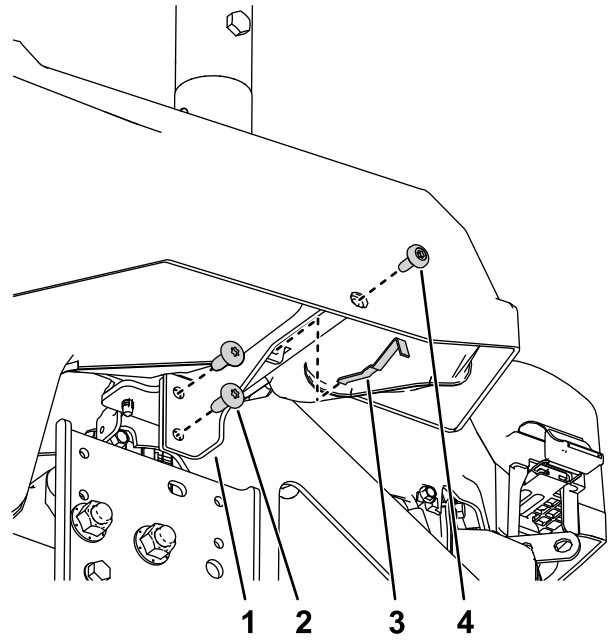

Figure 14

- | | |
|---|---------------------|
| 1. Left pod bracket | 3. Fuel-tank spring |
| 2. Thread-forming screw (5/16 x 3/4 inch) | 4. Shoulder bolt |

3. Install the right pod bracket to the machine frame using 2 thread-forming screws (5/16 x 3/4 inch) and the parts removed in 1 Preparing the Machine (page 3) as shown in Figure 3.
4. Install the bumper to the left pod bracket (Figure 8).

5

Completing the Installation

Parts needed for this procedure:

1	ROPS tube
2	Bolt (3/8 x 2-1/2 inches)
2	Locknut (3/8 inch)
4	Suitcase weight (For machines with a bagger installed only)
2	Bolt (3/8 x 3-3/4 inches)

Procedure

1. Install the rear tires as shown in [Figure 2](#).
2. Lower the machine; refer to your machine *Operator's Manual*.
3. Lower the seat.
4. With the ROPS tube angle toward the rear of the machine, install the ROPS tube to the ROPS mounts with 2 bolts (3/8 x 2-1/2 inches) and 2 locknuts (3/8 inch) as shown in [Figure 15](#).
5. **For machines with a bagger installed only:** Install the included additional suitcase weights to the machine using 2 bolts (3/8 x 3-3/4 inches) as necessary according to the table below ([Figure 16](#)).

Type of Deck	Total Weights Required
42-inch stamped deck	11
42-inch fabricated deck	10
50-inch fabricated deck	8
54-inch fabricated deck	6
60-inch fabricated deck	6

Note: The weight brackets will hold up to 8 suitcase weights between the front edge of the bracket and the machine; any additional weights must be mounted to the front of the weight brackets.

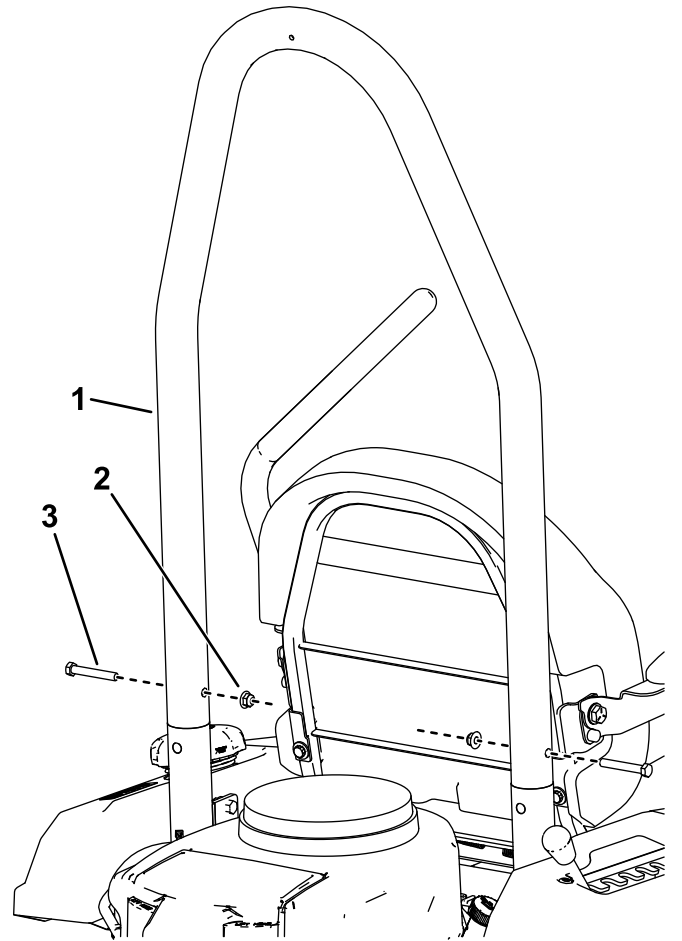

Figure 15

1. ROPS tube
2. Locknut (3/8 inch)
3. Bolt (3/8 x 2-1/2 inches)

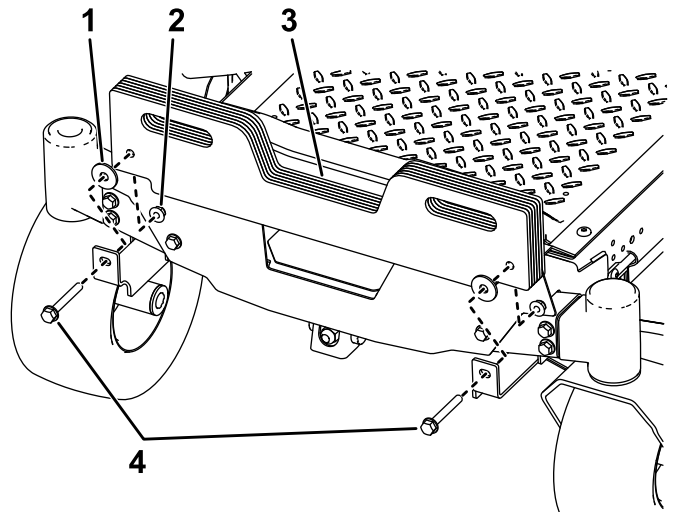

Figure 16

1. Washer
2. Locknut
3. Suitcase weight
4. Bolt (3/8 x 3-3/4 inches)

Notes:



Count on it.