



Cab Kit

Workman® GTX Utility Vehicle

Model No. 07142—Serial No. 405330001 and Up

Operator's Manual

Important: The Power Converter Kit is required to use the cab on a Workman GTX Electric utility vehicle. Contact your authorized Toro distributor for more information.

Important: The Spring Kit is required to use the cab on a Workman GTX utility vehicle. The Spring Kit should be installed only by qualified Toro Service Technicians using approved tools. Improper removal, disassembly, or installation of the spring assembly poses a danger to you and bystanders. Please contact your authorized Toro distributor for the appropriate tools and proper installation of this kit.

Safety

⚠ WARNING

The compressed spring in the spring and shock assembly represents a stored-energy hazard. If the spring is not properly retained during compression or removal, it can injure you and/or bystanders.

- Always use the approved Toro spring-compression tool to compress the spring in a secure position when removing the retention collar.
- Always use care when removing pressure from the compressed spring.

Safety and Instructional Decals



Safety decals and instructions are easily visible to the operator and are located near any area of potential danger. Replace any decal that is damaged or missing.



133-1016

decal133-1016

1. Warning—read the *Operator's Manual*; wear the seatbelt, and avoid tipping the machine.
2. Warning—wear hearing protection.



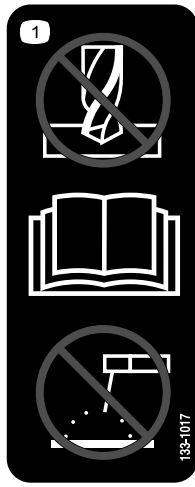

133-1017

decal133-1017

1. Do not repair or revise—read the *Operator's Manual*.

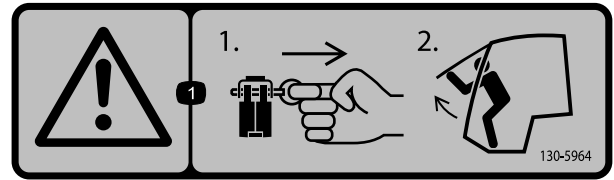

decal130-5964

130-5964

1. Warning—in the event of an emergency 1) Pull the locking pin out of each hinge; 2) Push the front window out to exit.

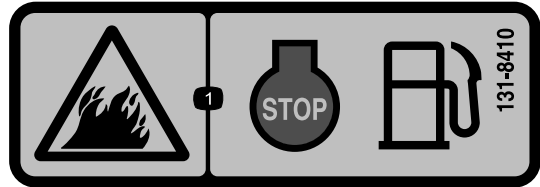

decal131-8410

131-8410

1. Fire hazard—shut off the engine before fueling.



decal120-9570

120-9570

1. Warning—stay away from moving parts, keep all guards and shields in place.

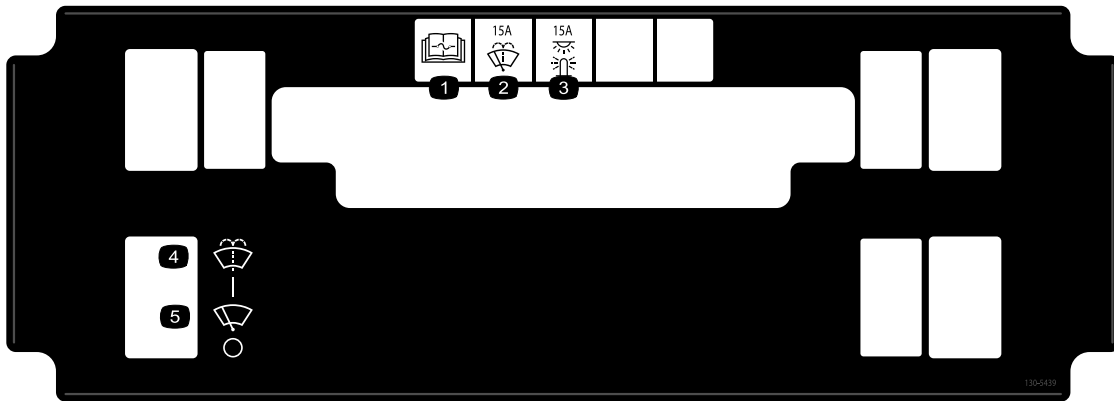

decal130-5439

130-5439

- | | |
|--|---------------------|
| 1. Read the <i>Operator's Manual</i> for information on fuses. | 4. Windshield spray |
| 2. Windshield wiper—15 A | 5. Windshield wiper |
| 3. Lights—15 A | |

Setup

Loose Parts

Use the chart below to verify that all parts have been shipped.

Procedure	Description	Qty.	Use
1	No parts required	–	Prepare the machine.
2	No parts required	–	Remove the strut assembly (for machines with Serial No. 403448001 and before only).
3	Spring	2	Install the springs (for machines with Serial No. 403448001 and before).
4	No parts required	–	Install the strut assembly (for machines with Serial No. 403448001 and before).
5	Floor-plate support Flange-head bolt (5/16 x 1-1/4 inches) Flange nut (5/16 inch) Left cab support Right cab support Hex-head bolt (3/8 x 1-1/4 inch) Flange nut (3/8 inch) Washer (3/8 inch)	2 16 16 1 1 4 4 4	Install the supports.
6	Cab frame Back foam seal Back foam seal carpet Flange-head bolt (5/16 x 1-1/4 inches) Flange nut (5/16 inch) Flat washer (5/16 inch) Support plate Right, front foam seal Left, front foam seal Upper, rear foam seal Foam seal Hex-head bolt (3/8 x 1-1/4 inches) Flange nut (3/8 inch) Washer (3/8 inch)	1 1 1 4 4 4 2 1 1 1 2 6 6 6	Install the cab.
7	Fuse block Hex-washer head screw (#10 x 3/4 inch)—for electric machines with Serial No. 403448001 and after only Serrated nut (#10)—for electric machines with Serial No. 403448001 and after only Self-tapping screw—for gasoline machines with Serial No. 403448001 and after only Fuse (15 A)	1 2 2 2 1	Route the wire harness.
8	Cab adapter wire harness—for electric machines with Serial No. 403448001 and after only.	1	Install the cab adapter wire harness.

1

Preparing the Machine

No Parts Required

Procedure

1. Park the machine on a level surface, set the parking brake, shut off the engine, and remove the key.
2. Raise the bed until the bed prop rod is fully engaged; refer to the *Operator's Manual* for the machine.
3. Remove the seat base.
4. Disconnect the negative battery cable; refer to your *Operator's Manual*.

2

Removing the Strut Assembly

For Machines with Serial No. 403448001 and Before Only

No Parts Required

Procedure

Note: If your machine unit has the silver springs installed, skip this step.

1. Remove the front wheel.
2. Remove the hex-head bolt (3/8 x 4-3/4 inches) and flange nut (3/8 inch) from the spindle ([Figure 1](#)).
3. Remove the hex-head bolt (3/8 x 3-1/2 inches) and flange nut (3/8 inch) from the control arm ([Figure 1](#)).
4. Remove the hex-head bolt (1/2 x 2-1/4 inches) and locknut (1/2 inch) securing the strut assembly to the upper frame ([Figure 1](#)).
5. Remove the strut assembly ([Figure 1](#)).

Note: Repeat this procedure for the other side of the machine.

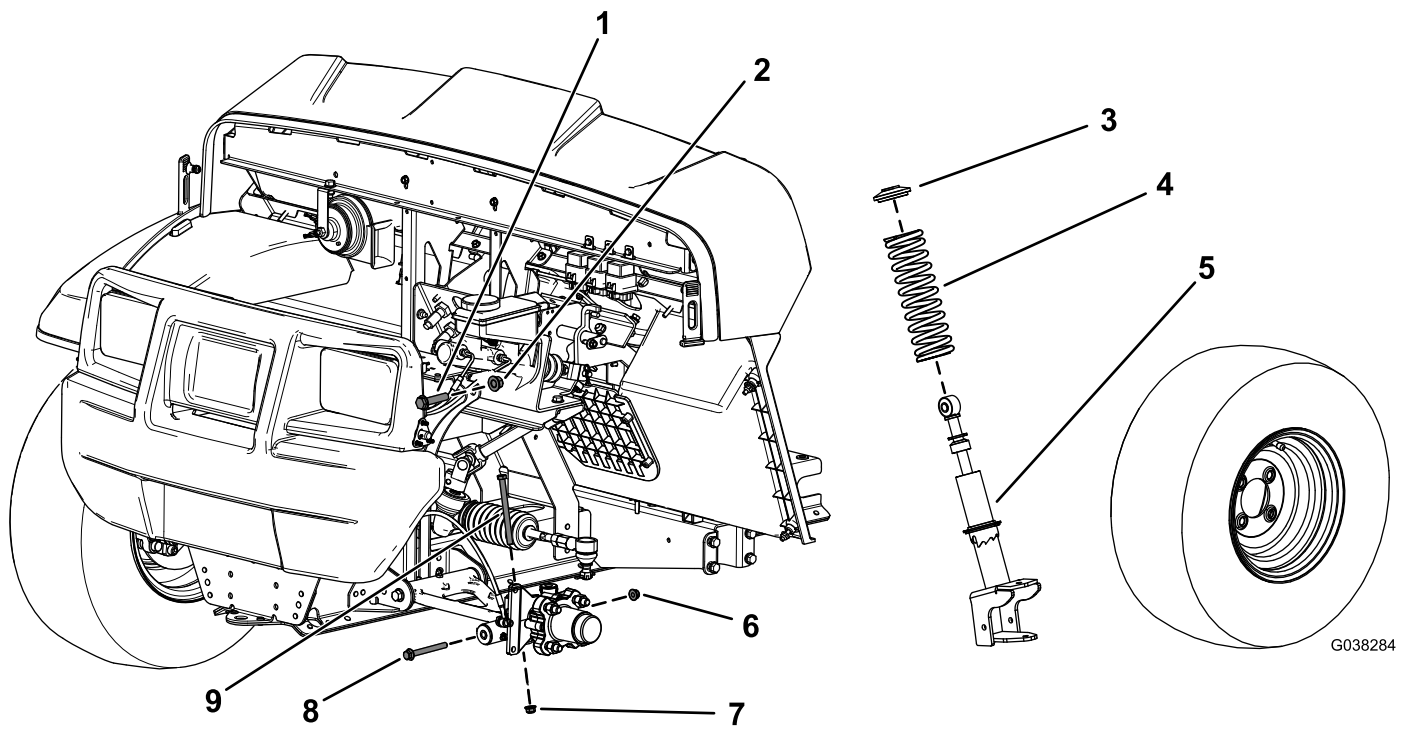

Figure 1

Some parts not shown for clarity

- | | |
|---------------------------------------|--|
| 1. Hex-head bolt (1/2 x 2-1/4 inches) | 6. Flange nut (3/8 inch)—from the control arm |
| 2. Locknut (1/2 inch) | 7. Flange nut (3/8 inch)—from the spindle |
| 3. Collar | 8. Hex-head bolt (3/8 x 3-1/2 inches)—from the control arm |
| 4. Spring | 9. Hex-head bolt (3/8 x 4-3/4 inches)—from the spindle |
| 5. Strut assembly | |

3

Installing the Springs

For Machines with Serial No. 403448001 and Before Only

Parts needed for this procedure:

2	Spring
---	--------

Procedure

Use an approved Toro spring-compression tool to remove and install springs of the strut assembly. Contact your authorized Toro distributor.

1. Place the strut assembly into the compression tool and use the tool to compress the spring.
2. While the spring is compressed, remove the collar.
3. Remove the spring from the strut assembly (Figure 1).
4. Install the new spring over the existing strut assembly (Figure 1).
5. Using the Toro spring-compression tool, compress the spring.
6. While the spring is compressed, install the collar.
7. Carefully release pressure on the spring, allowing it to seat on the collar.
8. Remove the strut assembly from the compression tool.

Note: Repeat this procedure for the other side of the machine.

4

Installing the Strut Assembly

For Machines with Serial No. 403448001 and Before Only

No Parts Required

Procedure

1. Install strut assembly to the machine.
2. Secure the upper portion of the strut assembly to the frame using the upper, hex-head bolt (1/2 x 2-1/4 inches) and locknut (1/2 inch) as shown in Figure 1.
3. Torque the hex-head bolt (1/2 x 2-1/4 inches) to 91 to 113 N·m (67 to 83 ft-lb).
4. Install the hex-head bolt (3/8 x 4-3/4 inches) and flange nut (3/8 inch) to the spindle (Figure 1).
5. Torque the hex-head bolt (3/8 x 4-3/4 inches) to 37 to 45 N·m (27 to 33 ft-lb).
6. Secure the lower portion of the strut assembly to the control arm using the hex-head bolt (3/8 x 3-1/2 inches) and flange nut (3/8 inch) as shown in Figure 1.
7. Torque the hex-head bolt (3/8 x 3-1/2 inches) to 37 to 45 N·m (27 to 33 ft-lb).
8. Install the front wheel.

Note: Repeat this procedure for the other side of the machine.

5

Installing the Supports

Parts needed for this procedure:

2	Floor-plate support
16	Flange-head bolt (5/16 x 1-1/4 inches)
16	Flange nut (5/16 inch)
1	Left cab support
1	Right cab support
4	Hex-head bolt (3/8 x 1-1/4 inch)
4	Flange nut (3/8 inch)
4	Washer (3/8 inch)

Procedure

1. Remove the 4 screws (1/4 x 1-1/4 inches) and 4 nuts (1/4 inch) from the floor plate (Figure 2).

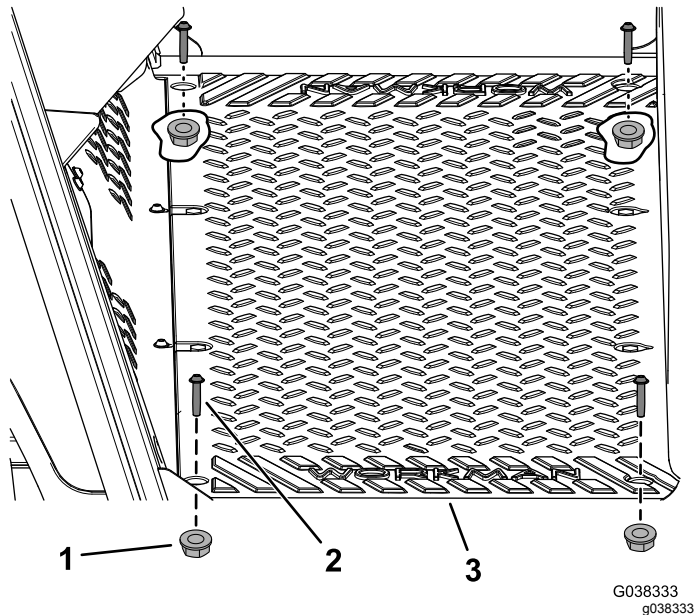

Figure 2

1. Nut (1/4 inch)
2. Screw (1/4 x 1-1/4 inches)
3. Floor plate

2. Use a floor jack under the frame to support the front of the machine (Figure 3).

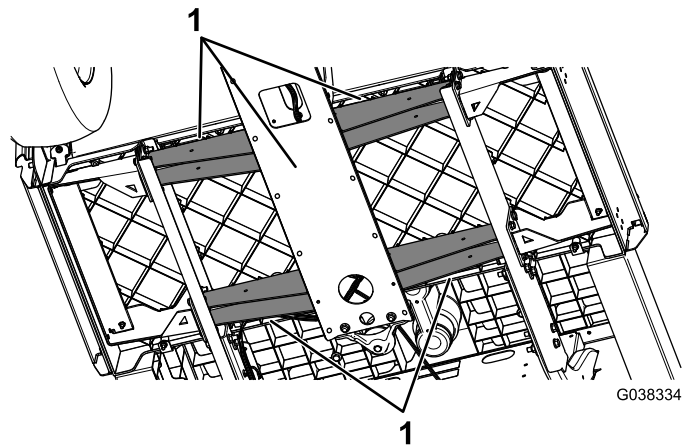

Figure 3

1. Frame

3. Remove 1 of the existing floor-plate supports (Figure 4).

Important: Do not remove both of the existing floor-plate supports simultaneously.

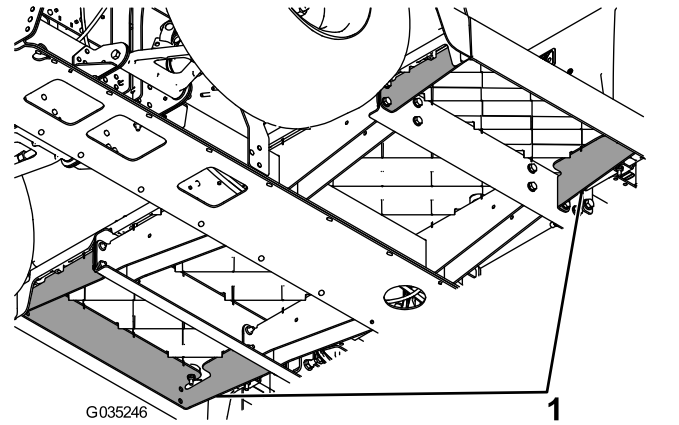

Figure 4

1. Existing floor-plate supports

- Install a new floor-plate support using 8 flange-head bolts (5/16 x 1-1/4 inches) and 8 flange nuts (5/16 inch) as shown in [Figure 5](#).

Note: Torque the flange-head bolts (5/16 x 1-1/4 inches) to 34 N·m (25 ft-lb).

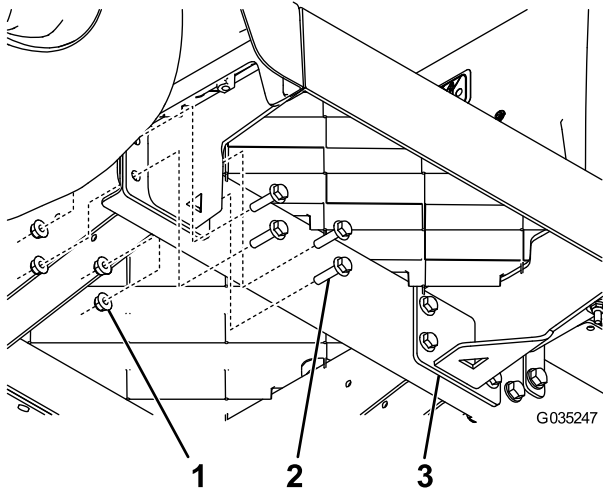

Figure 5

- Flange nut (5/16 inch)
- Flange-head bolt (5/16 x 1-1/4 inches)
- Floor-plate support

- Remove the other existing floor-plate support ([Figure 4](#)).
- Install the other new floor-plate support using 8 flange-head bolts (5/16 x 1-1/4 inches) and 8 flange nuts (5/16 inch) as shown in [Figure 5](#).
- Install the previously removed 4 screws (1/4 x 1-1/4 inches) and 4 nuts (1/4 inch) into the floor plate ([Figure 2](#)).

- Using the new floor-plate supports as a guide, drill 3 holes (3/8-inch diameter) into each floor plate ([Figure 6](#)).

Important: Drill only the front 2 holes on the new floor-plate supports and the farthest, rear hole; as shown in [Figure 6](#).

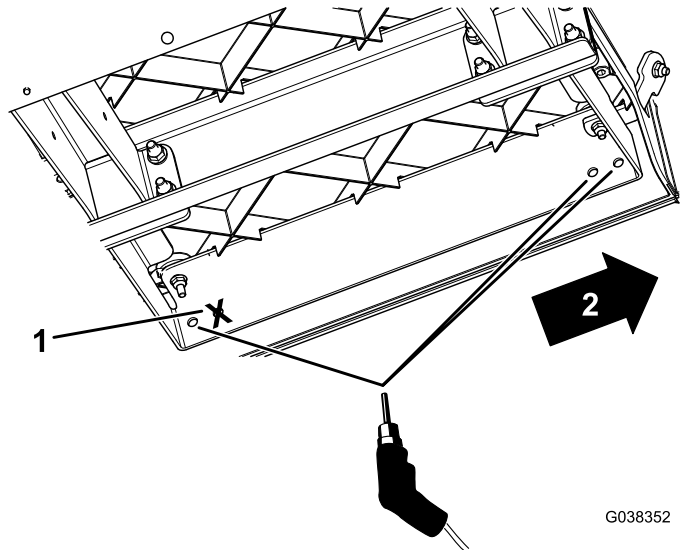

Figure 6

- Do not drill this hole.
- Front of the machine

- Loosely attach the left and right cab supports to the machine using the hex-head bolts (3/8 x 1-1/4 inch), washers (3/8 inch), and flange nuts (3/8 inch) as shown in [Figure 7](#).

Note: Do not tighten the bolts at this time.

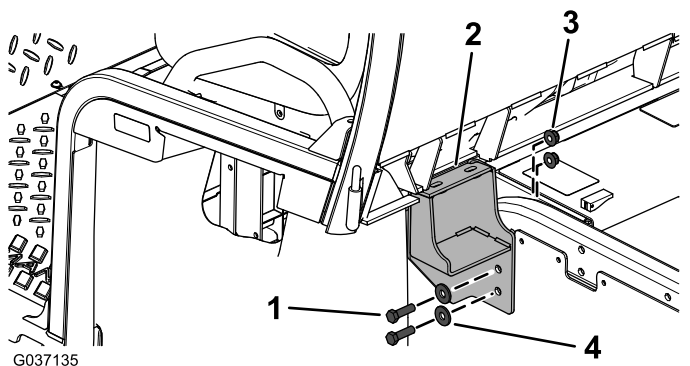

Figure 7

- Hex-head bolt (3/8 x 1-1/4 inch)
- Cab support
- Flange nut (3/8 inch)
- Washer (3/8 inch)

6

Installing the Cab

Parts needed for this procedure:

1	Cab frame
1	Back foam seal
1	Back foam seal carpet
4	Flange-head bolt (5/16 x 1-1/4 inches)
4	Flange nut (5/16 inch)
4	Flat washer (5/16 inch)
2	Support plate
1	Right, front foam seal
1	Left, front foam seal
1	Upper, rear foam seal
2	Foam seal
6	Hex-head bolt (3/8 x 1-1/4 inches)
6	Flange nut (3/8 inch)
6	Washer (3/8 inch)

Procedure

1. Remove the backing from the back foam seal and attach the seal to the machine as shown in [Figure 8](#).

Important: Ensure that the underside of the back foam seal with the adhesive faces the top of the rail surface.

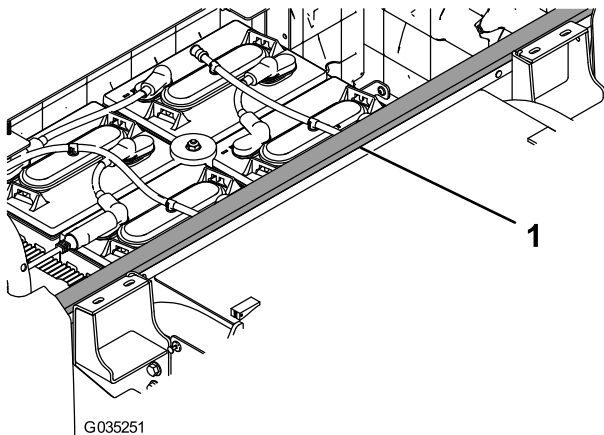

Figure 8

1. Back foam seal

2. Remove the 3 screws and 3 nuts securing the left handhold, and remove it ([Figure 9](#)).

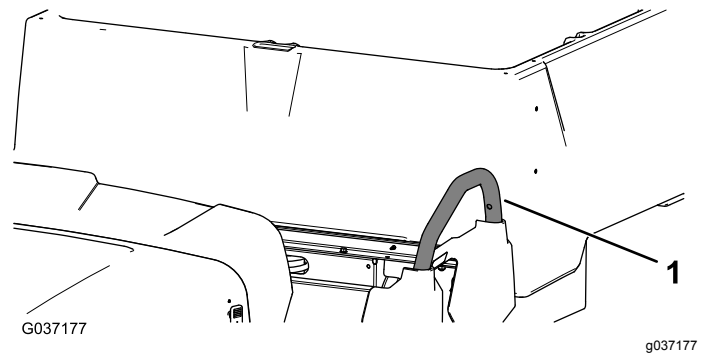

Figure 9

1. Handhold

3. Install the front sealing foam if it is not already installed ([Figure 10](#)).

Note: Ensure that you install the front sealing foam onto the cab before you install the cab onto the machine.

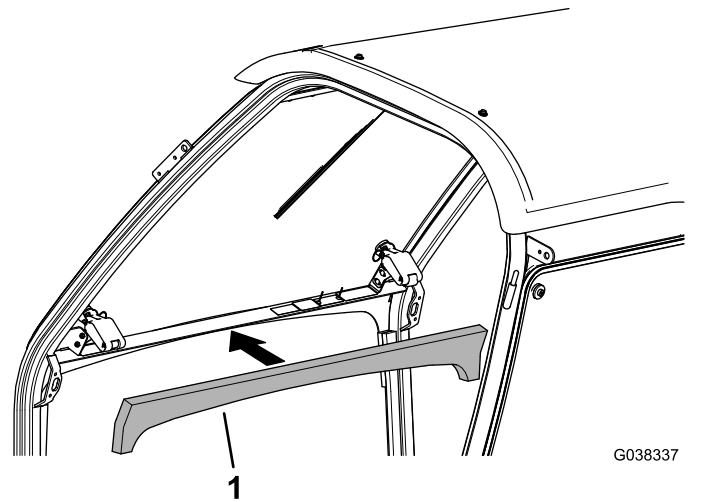

Figure 10

1. Front sealing foam

- Lift the cab frame using the lift points and place it on the machine (Figure 11).

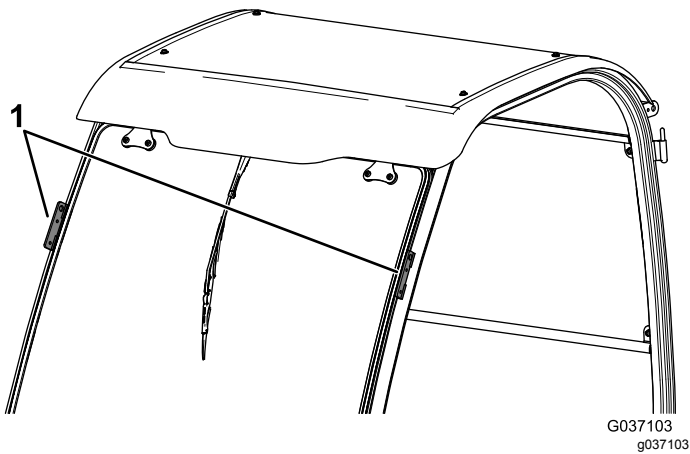

Figure 11

- Lift points

- Secure the sides of the cab frame to the machine using 6 hex-head bolts (3/8 x 1-1/4 inches), 6 washers (3/8 inch), and 6 flange nuts (3/8 inch) as shown in Figure 12.

Note: Torque the hex-head bolts (3/8 x 1-1/4 inches) to 58 N·m (43 ft-lb).

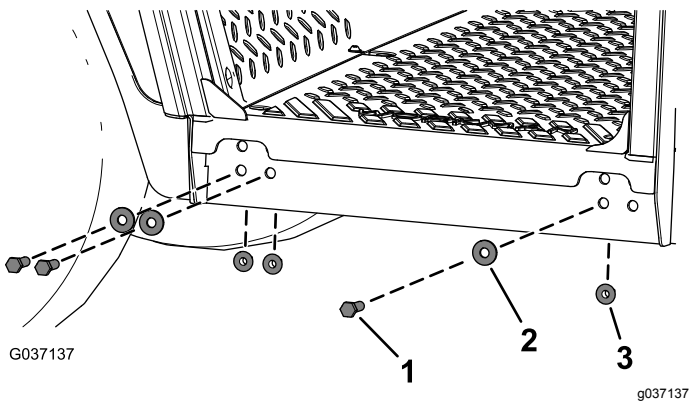

Figure 12

- Hex-head bolt (3/8 x 1-1/4 inches)
- Washer (3/8 inch)
- Flange nut (3/8 inch)

- Secure the back of the cab frame to the left and right supports using 4 flange-head bolts (5/16 x 1-1/4 inches), 2 support plates, 4 flat washers, and 4 flange nuts (5/16 inch) as shown in Figure 13.

Note: Torque the bolts to 34 N·m (25 ft-lb).

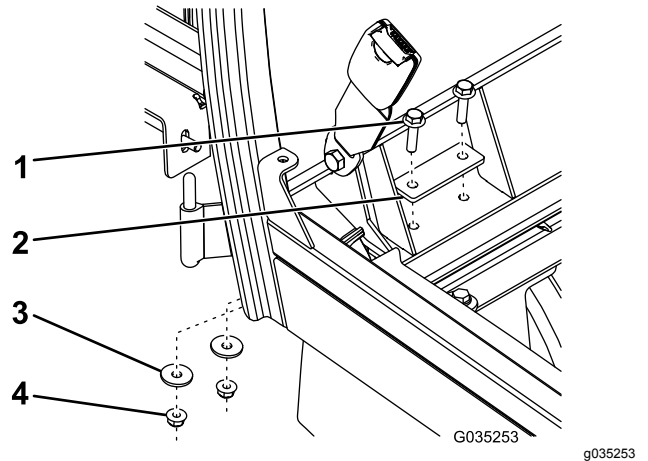

Figure 13

- Flange-head bolt (5/16 x 1-1/4 inches)
- Support plate
- Flat washer
- Flange nut (5/16 inch)

- Tighten the left and right supports, and torque the bolts to 58 N·m (43 ft-lb) as shown in Figure 7.
- Install the previously removed left handhold using the 3 screws and 3 nuts (Figure 9).
- Install the upper, rear foam seal (Figure 14).

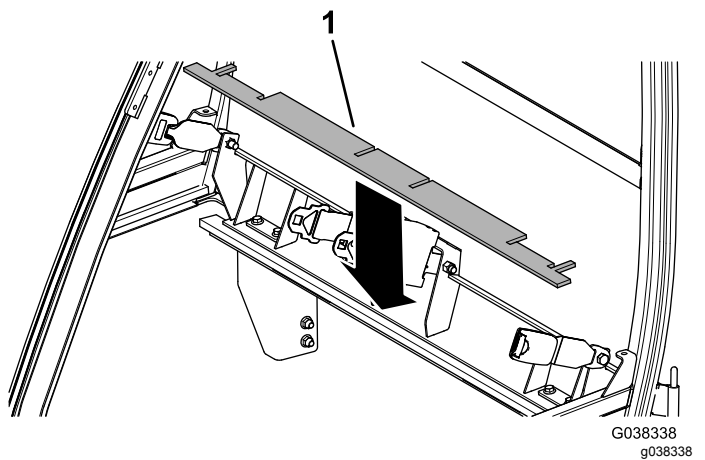

Figure 14

- Upper, rear foam seal

10. Install the seat base.

Note: You may need to position the 2 center seat-belt anchors to allow the seat to drop into place. Loosen the 2 locknuts (7/16 inch) on the 2 center seat-belt anchors, and tighten the 2 locknuts (7/16 inch) to 72 to 88 N·m (53 to 65 ft-lb) after adjusting the position.

11. Remove the backing from the right, front and left, front foam seals and attach the seals to the machine (Figure 15).

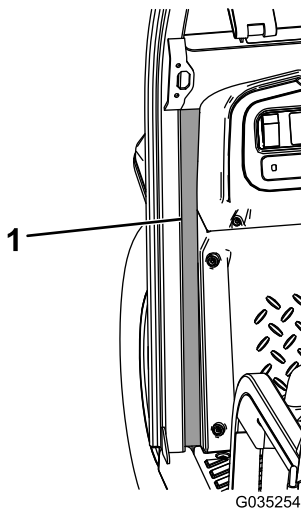

Figure 15

1. Left, front foam seal

12. Remove the backing from the foam seal and attach the seal to the right side of the machine (Figure 16).

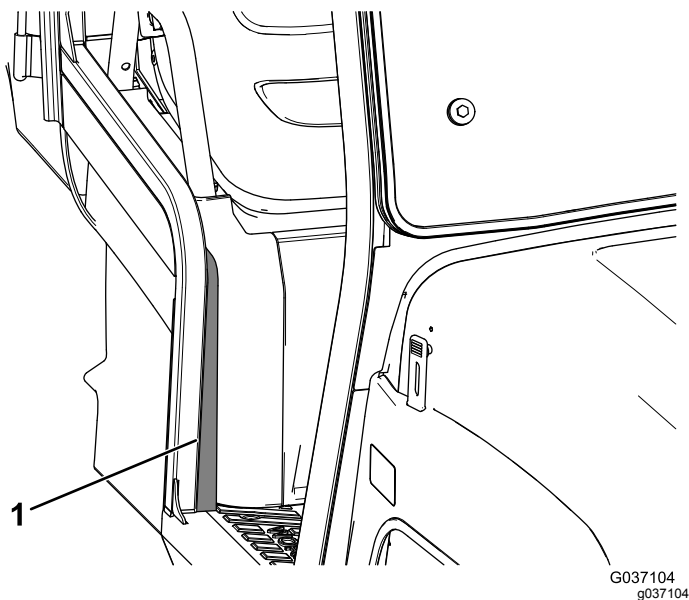

Figure 16
Right Side Shown

1. Foam seal

7

Routing the Wire Harness

Parts needed for this procedure:

1	Fuse block
2	Hex-washer head screw (#10 x 3/4 inch)—for electric machines with Serial No. 403448001 and after only
2	Serrated nut (#10)—for electric machines with Serial No. 403448001 and after only
2	Self-tapping screw—for gasoline machines with Serial No. 403448001 and after only
1	Fuse (15 A)

For Electric Machines

Important: The Power Converter Kit is required to use the cab on a Workman GTX Electric utility vehicle. Contact your authorized Toro distributor for more information.

1. Install the new fuse block as follows:
 - For machines with Serial No. 403448001 and before, snap the new fuse block onto the existing fuse block on the machine (Figure 17).

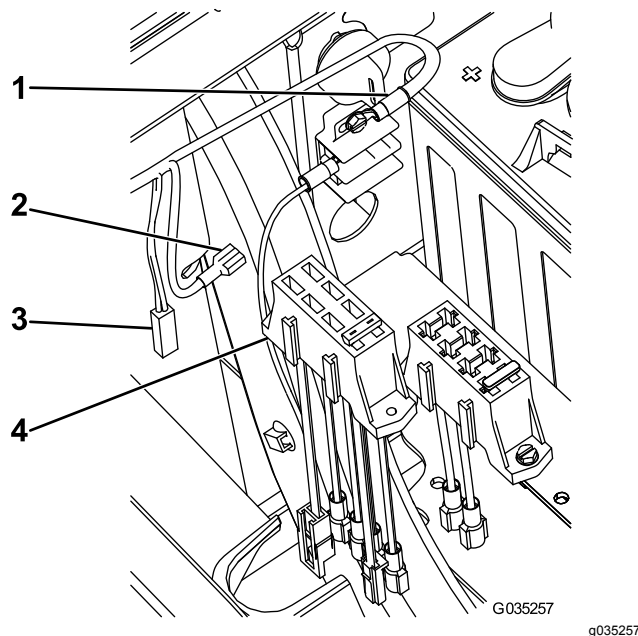

Figure 17

1. To ground
2. To the fused wire
3. To the optional washer pump kit
4. New fuse block

- For machines with Serial No. 403448001 and after, secure the new fuse block using

the 2 hex-washer head screws (#10 x 3/4 inch) and 2 serrated nuts (#10) as shown in [Figure 18](#).

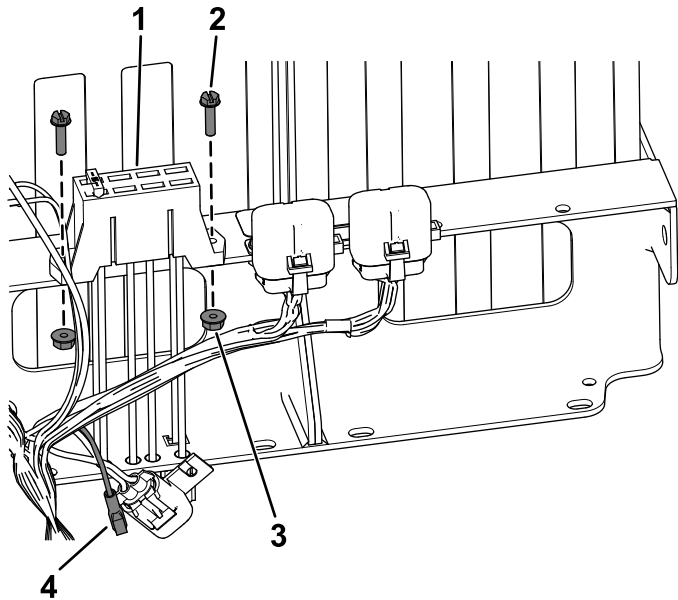

Figure 18

g290937

- | | |
|---|-----------------------|
| 1. New fuse block | 3. Serrated nut (#10) |
| 2. Hex-washer head screw (#10 x 3/4 inch) | 4. Female connector |

- For machines with Serial No. 403448001 and after, connect the female connector on the harness to the new fuse block ([Figure 18](#)).
- Connect the large connector on the new fuse block to the optional power cable on the existing fuse block ([Figure 17](#)).

- Route the wire harness behind the cab and under the seat, and secure the clip on the wire harness to the side panel ([Figure 19](#)).

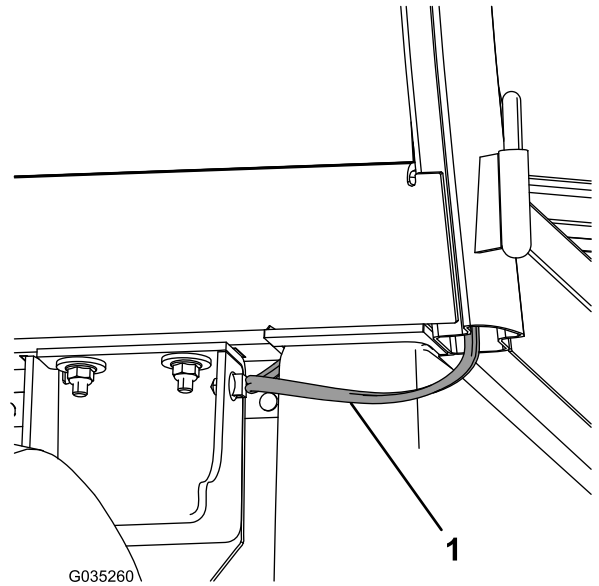

Figure 19

g035260

- Wire harness

- Install the black ground wire to the ground wire on the Power Converter Kit wire harness ([Figure 20](#)).

Note: The black terminal ring is not used.

- Install the red power wire to the power wire on the Power Converter Kit wire harness ([Figure 20](#)).

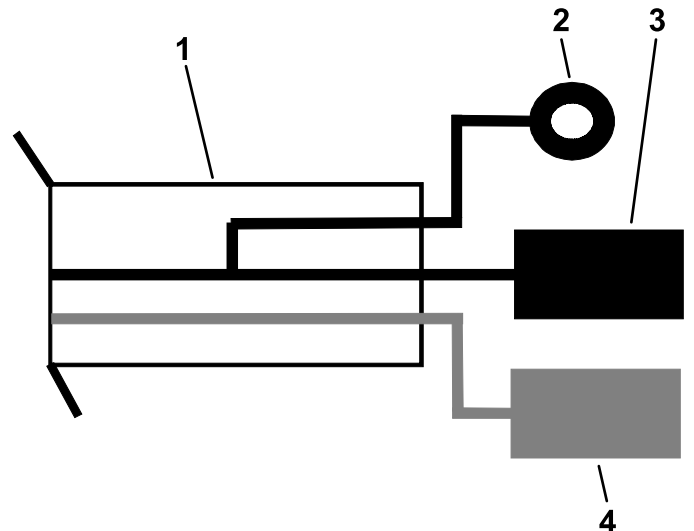

Figure 20

g278776

- | | |
|--|--|
| 1. Cab wire harness | 3. Black ground wire with spade terminal |
| 2. Black ground wire with terminal ring (not used) | 4. Red power wire with spade terminal |

7. Connect the remaining wire to the fused wire on the new fuse block (Figure 17).
8. Lower the bed and connect the battery; refer to the *Operator's Manual*.
9. Install the previously removed seat base.

4. Install the black terminal ring to the ground block on the machine (Figure 22).
5. Install the red power wire into an empty slot on the machine fuse block (Figure 22).

Note: Install an additional fuse block if there are no remaining slots open in a fuse block.

For Gasoline/Petrol or EFI Machines

1. Install the new fuse block as follows:
 - **For machines with Serial No. 403448001 and before**, snap the new fuse block onto the existing fuse block on the machine (Figure 17).
 - **For machines with Serial No. 403448001 and after**, secure the new fuse block using the 2 self-tapping screws as shown in Figure 21.

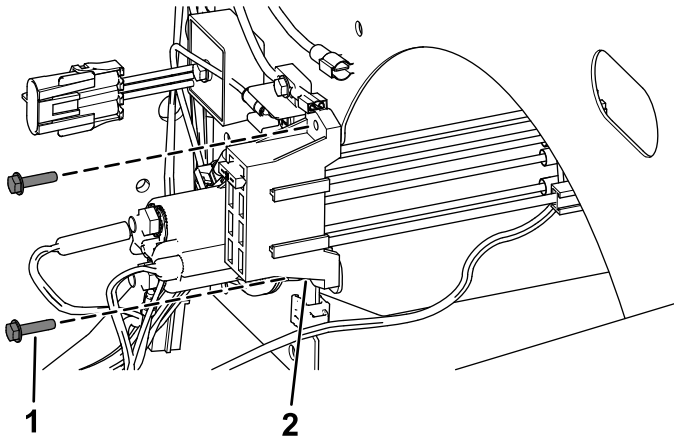

Figure 21

1. Self-tapping screw
2. New fuse block

2. Connect the large connector on the new fuse block to the optional power cable on the existing fuse block (Figure 17).
3. Route the wire harness behind the cab and under the seat, and secure the clip on the wire harness to the side panel (Figure 19).

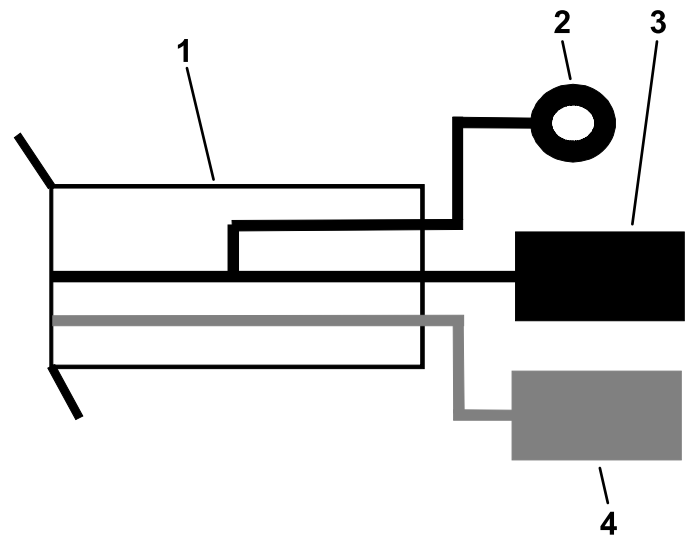

Figure 22

1. Cab wire harness
2. Black ground wire with terminal ring
3. Black ground wire with spade terminal
4. Red power wire with spade terminal

6. Connect the remaining wire to the fused wire on the new fuse block (Figure 17).
7. Lower the bed and connect the battery; refer to the *Operator's Manual*.
8. Install the previously removed seat base.

8

Installing the Cab Adapter Wire Harness

Electric Machines Only

Parts needed for this procedure:

1	Cab adapter wire harness—for electric machines with Serial No. 403448001 and after only.
---	---

Procedure

For machines with **Serial No. 403448001 and after**, install the cab adapter wire harness as follows:

1. Open the hood; refer to your machine *Operator's Manual*.
2. Disconnect the 4-pin plug on the main harness from the DC converter under the dash.

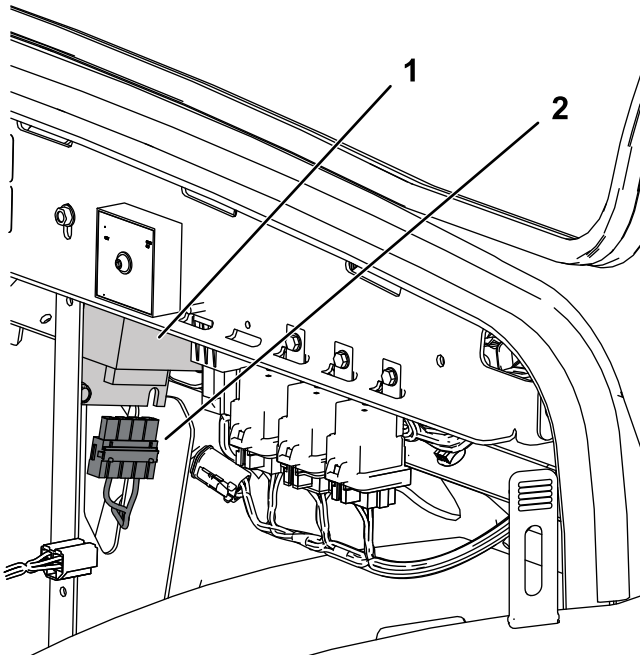

Figure 23

g299535

1. DC converter
2. 4-pin plug on the main harness.

3. Connect the 4-pin socket on the cab adapter wire harness to the 4-pin plug on the main harness.

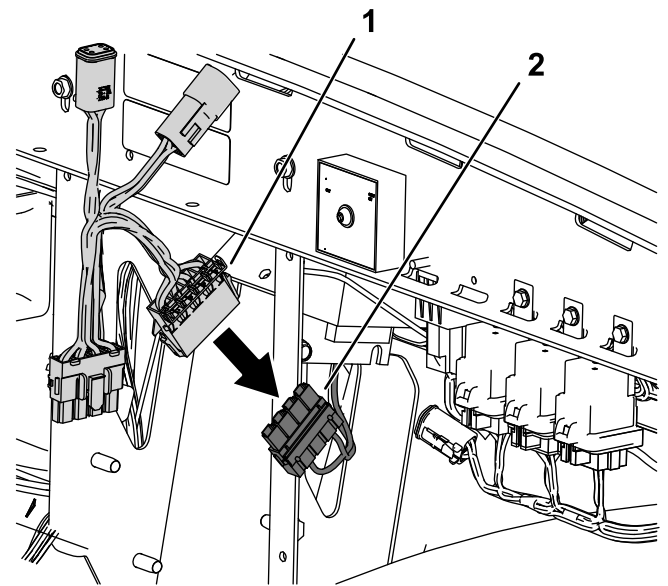

Figure 24

g299566

1. 4-pin socket on the cab adapter wire harness.
2. 4-pin plug on the main harness.

4. Connect the 4-pin plug on the cab adapter wire harness to the DC converter.

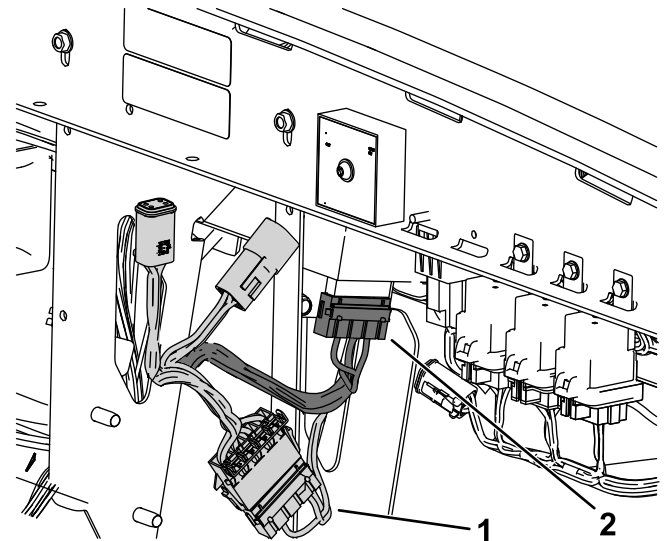

Figure 25

g299568

1. Cab adapter to the main harness connection.
2. Cab adapter to the DC converter connection.

5. Connect the loose square plug on the power converter wire harness to the cab adapter wire harness (Figure 26).

- Connect the loose square socket on the power converter wire harness to the cab adapter wire harness (Figure 26).

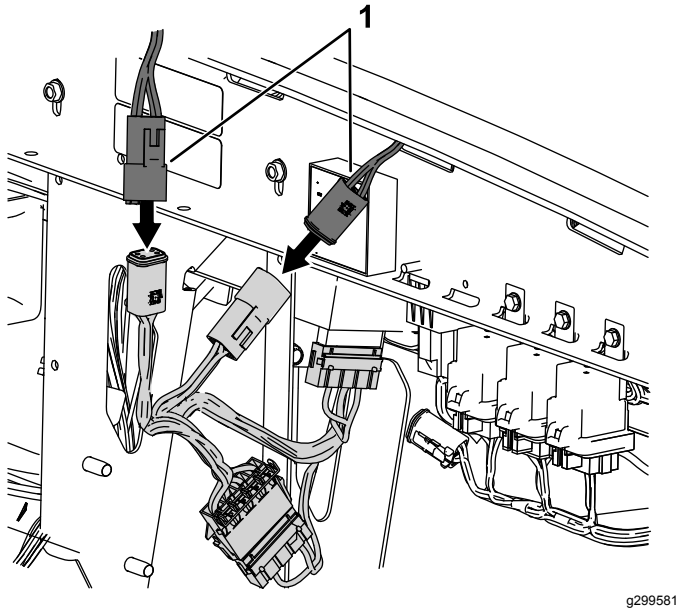

Figure 26

- Power converter harness connections to the cab adapter harness.

- Secure the hood; refer to your machine *Operator's Manual*.

Product Overview

Controls

Control Panel

Windshield-Wiper Switch

Click the switch forward to activate the windshield wipers (Figure 27).

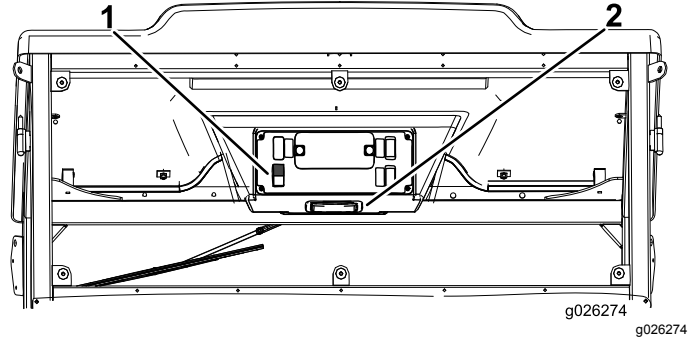

Figure 27

- Windshield-wiper control
- Light switch

Light Switch

Push the left or right side of the light plate to turn on the cab light (Figure 27).

Windshield Latch

Lift up on the latches to open the windshield (Figure 28). Press down on the latch to lock the windshield in the open position. Pull out and down on the latch to close and secure the windshield.

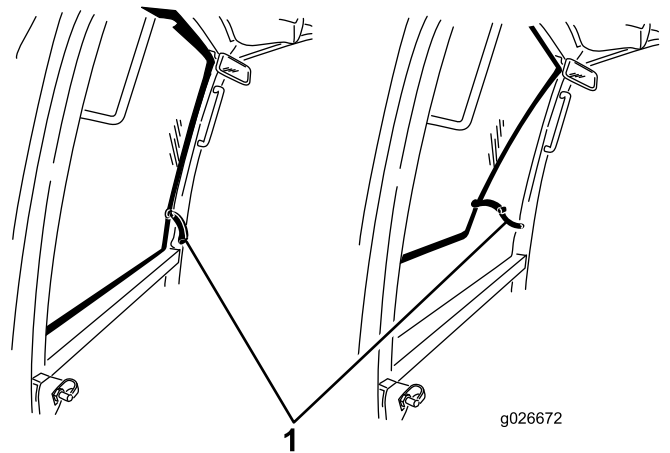

Figure 28

- Windshield latch



Count on it.