



TimeCutter® Riding Mowers

For All TimeCutter® Riding Mowers

Setup

Loose Parts

Use the chart below to verify that all parts have been shipped.

Procedure	Description	Qty.	Use
1	Seat back	1	Install the back cushion (machines with MyRide™ suspension system only).
	Flanged-hex bolt	2	
2	No parts required	–	Connect the battery.
3	No parts required	–	Attach the seat-tilt cable (non-MyRide machines only).
4	Rear hitch	1	Install the rear hitch.
	Bolt (5/16 x 1 inch)	2	
	Locknut (5/16 inch)	2	
5	No parts required	–	Set up the motion-control levers.
6	No parts required	–	Check the mower adjustment.
7	Key	1	Complete the setup.
	Hose coupling (not included with CE models)	1	
	Operator's Manual	1	
	Engine owner's manual (non-Toro engines)	1	
	Operator training material	1	

Note: Determine the left and right sides of the machine from the normal operating position.



1

Installing the Back Cushion

Machines with MyRide™
Suspension System Only

Parts needed for this procedure:

1	Seat back
2	Flanged-hex bolt

Procedure

1. Slide the seat back on to the seat base posts and align the holes.
2. Secure the seat back using 2 flanged-hex bolts (Figure 1). Torque the bolts to 24 N·m (18 ft·lb).

Note: The flange-hex bolts are installed into locking nuts on the seat back. You will need additional torque to overcome the locking feature in the nuts.

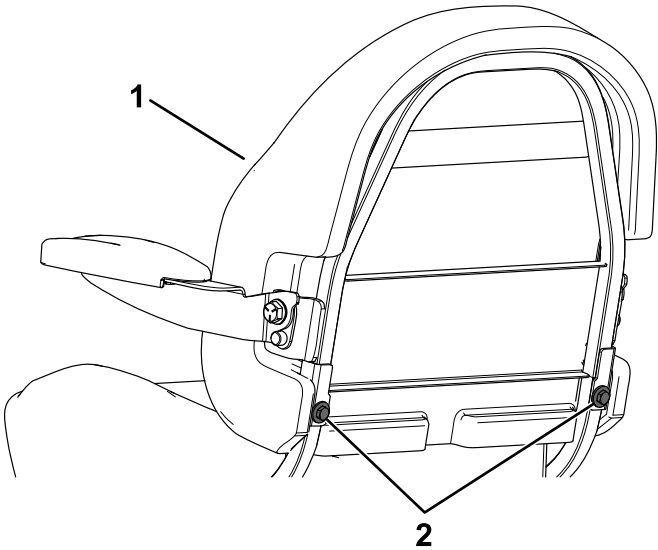

Figure 1

g298473

1. Seat back
2. Flanged-hex bolts

2

Connecting the Battery

No Parts Required

Procedure

1. Locate the battery and negative battery cable.
2. Remove the plastic cap from the negative battery post.
3. Remove the fasteners on the negative battery cable, and use them to secure the negative battery cable to the negative battery post (Figure 2).

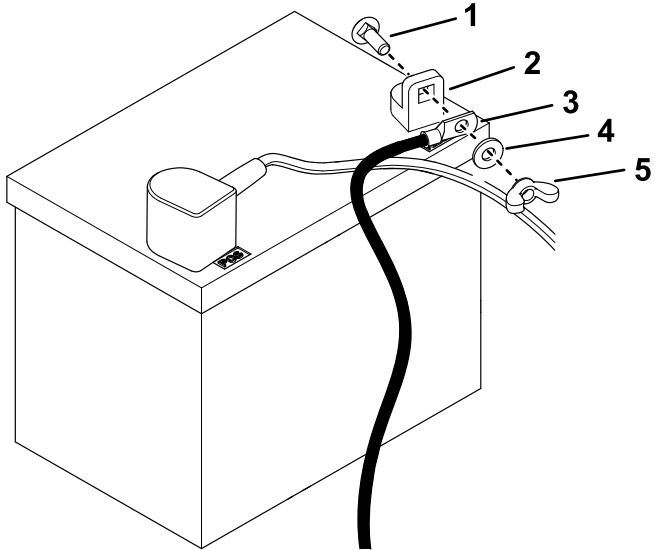

Figure 2

g303936

1. Carriage bolt
2. Negative battery post
3. Negative battery cable
4. Washer
5. Wing nut

3

Attaching the Seat-Tilt Cable

Non-MyRide Machines Only

No Parts Required

Procedure

1. Tilt the seat back partway.
2. Attach the seat-tilt cable from inside the seat pan (Figure 3).

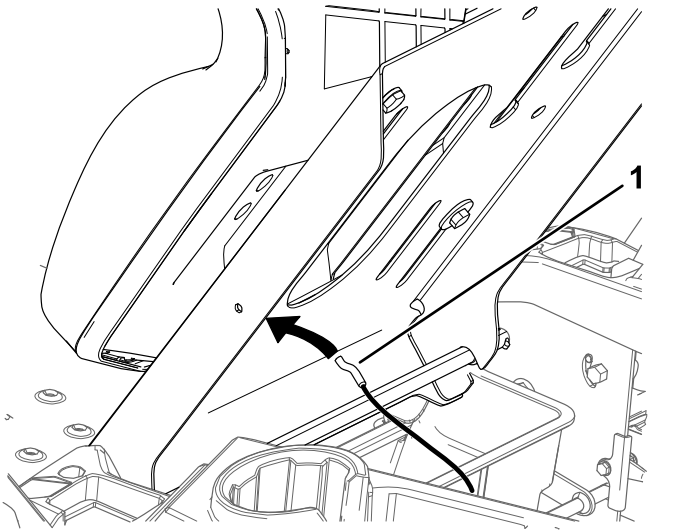

Figure 3

1. Seat-tilt cable

3. Lower the seat.

4

Installing the Rear Hitch

Parts needed for this procedure:

1	Rear hitch
2	Bolt (5/16 x 1 inch)
2	Locknut (5/16 inch)

Procedure

Install the bracket to the frame as shown in Figure 4 and Figure 5.

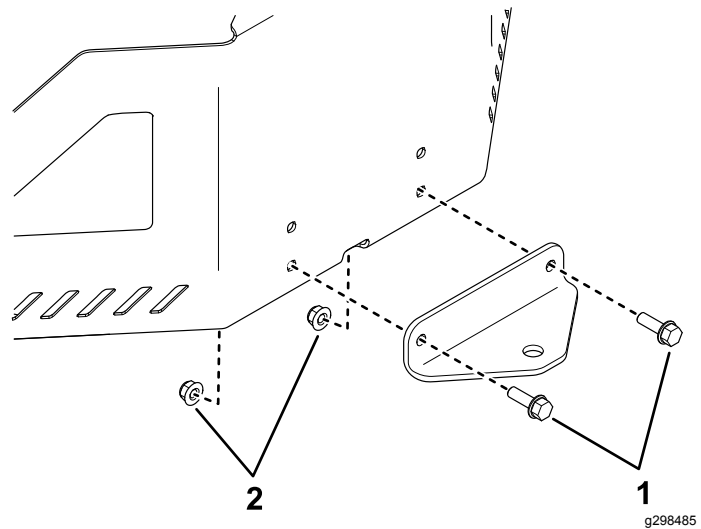

Figure 4
Before assembly

1. Bolts
2. Locknuts

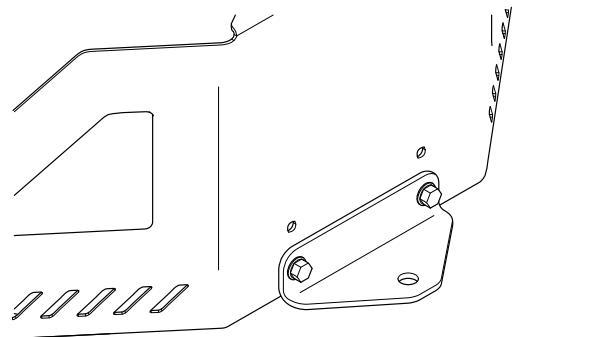

Figure 5
After assembly

5

Setting Up the Motion-Control Levers

No Parts Required

Procedure

1. Locate the motion-control levers attached, but folded down on the machine.
2. Remove the upper bolt (3/8 x 1 inch) and washer; loosen the lower bolt (3/8 x 1 inch).
3. Raise the motion control levers to the upright position.
4. Align the holes in the motion-control lever with the holes in the control-arm shaft, and install the bolt and washer removed previously. Repeat this for both control levers.

Note: Hand tighten all fasteners.

5. Move the motion-control levers to the park position, raise the seat, and move the control levers back to the center position (neutral).
6. Verify that the motion-control levers are properly aligned.

Note: Adjust as necessary. Tighten all fasteners.

6

Checking the Mower Adjustment

No Parts Required

Procedure

Adjust the side-to-side level and the front-to-rear blade slope. Use the relevant procedures in the *Operator's Manual* to verify that the deck is level, and make any adjustments as necessary. Refer to the *Operator's Manual* for more information.

7

Completing the Setup

Parts needed for this procedure:

1	Key
1	Hose coupling (not included with CE models)
1	<i>Operator's Manual</i>
1	Engine owner's manual (non-Toro engines)
1	Operator training material

Checking the Tire Pressure

Check the front and rear tires for proper inflation; refer to Checking the Tire Pressure in the *Operator's Manual* for the recommended inflation pressure.

Checking the Side-Discharge Chute

Remove the packing restraint holding the side discharge chute up and lower the chute into place.

Checking the Engine-Oil Level

Before you start the engine and use the machine, check the oil level in the engine crankcase; refer to Checking the Oil Level in the *Operator's Manual*.

Organizing the Material

Keep all the following items with the machine:

- Ignition key
- Hose coupling (not included in CE models)
- *Operator's Manual*
- Engine owners's manual (non-Toro engines)
- View the operator training material before operating the machine.