



**Boring Unit**  
**Dingo<sup>®</sup> Attachment**  
Model No. 22420—200000001 & Up

**Operator's Manual**



# Contents

	Page
Introduction .....	2
Safety .....	2
Safety Decals .....	3
Specifications .....	3
Stability Ratings .....	4
Installation .....	4
Installing Accessories .....	4
Removing an Accessory .....	4
Operation .....	4
Digging the Trenches .....	4
Boring the Hole .....	5
Reaming the Hole .....	6
Maintenance .....	6
Storage .....	6
Troubleshooting .....	7

## Introduction

We want you to be completely satisfied with your new product, so feel free to contact your local Authorized Service Dealer for help with service, genuine replacement parts, or other information you may require.

Whenever you contact your Authorized Service Dealer or the factory, always know the model and serial numbers of your product. These numbers will help the Service Dealer or Service Representative provide exact information about your specific product. You will find the model and serial number on a plate located on the right side of the drive head.

For your convenience, write the product model and serial numbers in the space below.

<p><b>Model No:</b> _____</p> <p><b>Serial No.</b> _____</p>
--

The warning system in this manual identifies potential hazards and has special safety messages that help you and others avoid personal injury, even death. **DANGER**, **WARNING** and **CAUTION** are signal words used to identify the level of hazard. However, regardless of the hazard, be extremely careful.

**DANGER** signals an extreme hazard that will cause serious injury or death if the recommended precautions are not followed.

**WARNING** signals a hazard that may cause serious injury or death if the recommended precautions are not followed.



**CAUTION** signals a hazard that may cause minor or moderate injury if the recommended precautions are not followed.

Two other words are also used to highlight information. “Important” calls attention to special mechanical information and “Note” emphasizes general information worthy of special attention.

The left and right side of the machine is determined by standing in the normal operator’s position.

## Safety

**Improper use or maintenance by the operator or owner can result in injury. To reduce the potential for injury, comply with these safety instructions and those in the traction unit Operator’s Manual. Always pay attention to the safety alert ⚠ symbol, which means CAUTION, WARNING, or DANGER—“personal safety instruction.” Failure to comply with the instruction may result in personal injury or death.**

	<b>DANGER</b>	
<p><b>POTENTIAL HAZARD</b></p> <ul style="list-style-type: none"> <li>• There may be buried power, gas, and/or telephone lines in the work area.</li> </ul> <p><b>WHAT CAN HAPPEN</b></p> <ul style="list-style-type: none"> <li>• Shock or explosion may occur.</li> </ul> <p><b>HOW TO AVOID THE HAZARD</b></p> <ul style="list-style-type: none"> <li>• Have the property or work area marked for buried lines and do not dig in marked areas.</li> </ul>		

**DANGER**

**POTENTIAL HAZARD**

- Rotating rod and bits can entangle loose clothing, hands, arms, legs, and feet.

**WHAT CAN HAPPEN**

- Rotating rod and bits can cause death or serious injury.

**HOW TO AVOID THE HAZARD**

- Keep at least ten feet from rotating parts, unless you are operating the rod guide tool.
- Never use anything but the rod guide tool for starting the rod and boring bit.
- Keep extremities and other parts of your body or clothing away from rotating parts.
- Do not wear loose clothing or jewelry while operating or assisting with the boring unit.
- Always turn off the traction unit before changing accessories.

**WARNING**

**POTENTIAL HAZARD**

- When the engine is off, attachments in the raised position can gradually lower.

**WHAT CAN HAPPEN**

- Someone nearby may be pinned or injured by the attachment as it lowers.

**HOW TO AVOID THE HAZARD**

- Always lower the attachment lift each time you shut off the traction unit.

**CAUTION**

**POTENTIAL HAZARD**

- If you step off of the platform with the loader arms raised, the machine could tip forward.

**WHAT CAN HAPPEN**

- Someone nearby may be pinned or injured.

**HOW TO AVOID THE HAZARD**

- Lower the loader arms before stepping off or the platform.

- Do not service the attachment unless rod rotation is stopped, the auxiliary hydraulics lever is moved to neutral, and the engine of the traction unit is stopped.
- Never use bolts or pins in place of push button connectors.

- Always use 2 people to operate the attachment, one to operate the traction unit and the other to guide the boring unit with the guide tool.
- Always use the guide tool to align the boring unit.
- Never straddle or stand on the rod when the engine is running.

## Safety Decals

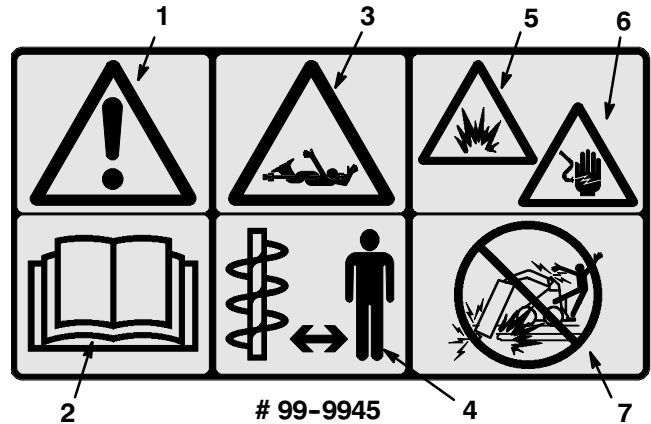

Figure 1

- Safety alert symbol
- Read operator's manual
- Full body entanglement
- Stay away from rotating shafts and augers
- Explosion hazard
- Electric shock hazard
- Do not dig in areas with buried gas or power lines



## Specifications

**Note:** Specifications and design are subject to change without notice.

Overall width	24 inches (61 cm)
Overall length	22 inches (56 cm)
Overall height	25 inches (63.5 cm)
Weight/Mass	120 lbs (54 Kg)
Boring diameter	1.25 to 3.5 inches (3.2 to 8.9 cm)
Rotation speed (at 11 gpm, 3000 rpm)	105 rpm
Rotation torque	629 ft/lb at 3000 psi (850 N·m at 207 bar)
Maximum hydraulic pressure	3000 psi (207 bar)

# Stability Ratings

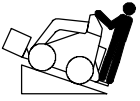
To determine the degree of slope you can traverse with the boring unit installed on a traction unit, find the stability rating for the hill position you want to travel in the table below, then find the degree of slope for the same rating and hill position in the Stability Data section of the traction unit operator’s manual.

Orientation	Stability Rating
<b>Front Uphill</b> 	<b>D</b>
<b>Rear Uphill</b> 	<b>B</b>
<b>Side Uphill</b> 	<b>C</b>

**Note:** If you have a traction unit other than the Dingo TX, the boring unit is rated for use without the counterweight. If you use the counterweight with the boring unit, the traction unit will be less stable in the front and side uphill positions.

! **WARNING** !

**POTENTIAL HAZARD**

- Exceeding the maximum slope can cause the traction unit to tip.

**WHAT CAN HAPPEN**

- If the traction unit tips, you or bystanders could be crushed.

**HOW TO AVOID THE HAZARD**

- Do not drive the the traction unit on a slope steeper that the maximum slope.

# Installation

Refer to your traction unit Operator’s Manual for information on installing and removing attachments on your traction unit.

## Installing Accessories

1. Stop the engine and wait for all moving parts to stop.

2. Slide the hex shaft of a rod, boring bit, or reamer into the socket. Align the hole in the socket with the push button connector (Fig. 2).
3. Press down the push button connector and push the shaft into the socket until the connector snaps into the hole in the socket (Fig. 2).

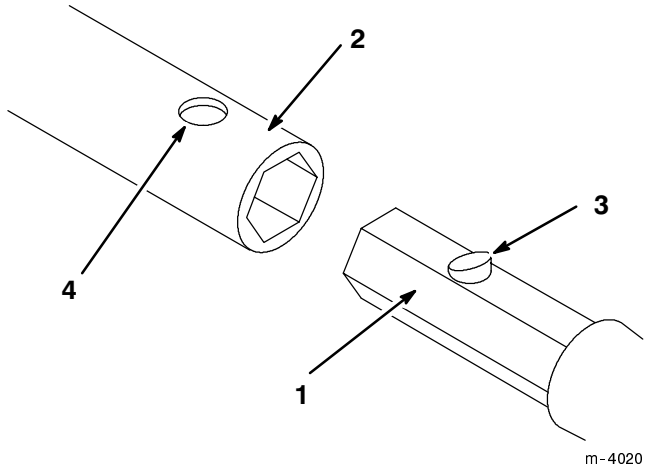

**Figure 2**

1. Accessory shaft
2. Socket
3. Push button connector
4. Hole

4. Repeat steps 2 and 3 for other accessories to be installed.

## Removing an Accessory

1. Stop the engine and wait for all moving parts to stop.
2. Press the push button connector securing the accessory shaft in the socket and pull the accessory free of the socket.

# Operation

**IMPORTANT:** Lift and move the attachment using the traction unit.

## Digging the Trenches

Before drilling under a walk or driveway, you must make an entrance and an exit trench on either side of the drilling area. Both trenches must be at least 6 inches wide and 18 inches deep. The entrance trench must be at least 7 feet long and the exit trench 3 to 6 feet long. The entrance trench should be perpendicular to the walk or driveway and the exit trench should be parallel to the walk or driveway. The exit trench should be centered across from the entrance trench (Fig. 3).

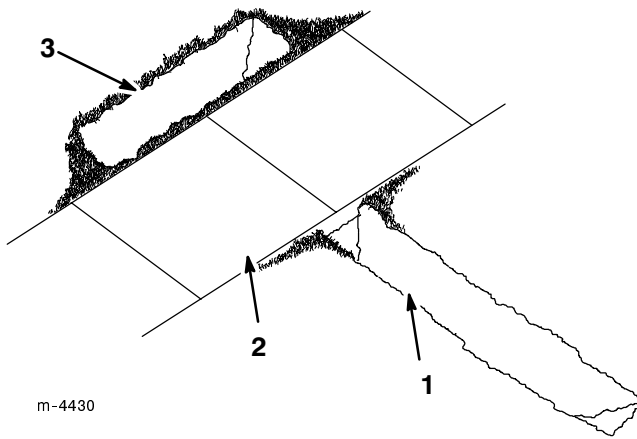

**Figure 3**

- |                    |                |
|--------------------|----------------|
| 1. Entrance trench | 3. Exit trench |
| 2. Sidewalk        |                |

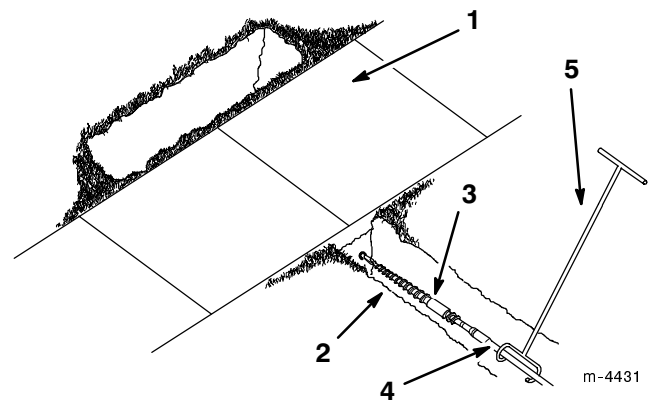

**Figure 4**

- |                         |                   |
|-------------------------|-------------------|
| 1. Sidewalk or driveway | 4. Rod            |
| 2. Entrance trench      | 5. Rod guide tool |
| 3. Boring bit           |                   |

## Boring the Hole

**IMPORTANT: Boring is a two person operation. Do not attempt to perform this operation by yourself.**

1. Position the traction unit with the drive head at the beginning of the trench and lower it to the appropriate depth.
2. Stop the engine and wait for all moving parts to stop.
3. Connect a rod and boring bit onto the drive head.
4. Connect the rod guide tool to the rod just behind the boring bit (Fig. 4).
5. With the person guiding the boring bit positioned to the right of the trench (Fig. 4), start the engine, move the pump selector valve to slow (turtle), position the throttle to within the middle of the RPM range, and pull the auxiliary hydraulics lever rearward to start the forward rotation of the boring bit.
6. Slowly move the traction unit forward, while the person with the rod guide tool guides the boring bit into the soil (Fig. 4).

7. Once the entire drill bit is in the soil, push the auxiliary hydraulics lever into neutral.
8. Stop the engine and wait for all moving parts to stop.
9. Check the grade of the rod. If the rod is not within the grade tolerances for the job being performed, start the engine and drive backward to pull the boring bit out of the soil, then repeat steps 5 through 9, making adjustments to correct the grade.
10. Remove the rod guide tool.
11. Start the engine and pull the auxiliary hydraulics lever rearward to start the boring bit.
12. Slowly move the traction unit forward as the boring bit digs into the soil.

**IMPORTANT: Do not drive too fast, forcing the bit into the soil. Allow the bit to progress at its own rate. Never push or pull the bit through the soil when the drive head is not turning.**

13. When about 6" of rod are left showing in the entrance trench or when the boring bit completely enters and bores into the far side of the exit trench, stop the traction unit, push the auxiliary hydraulics lever into neutral, and stop the engine.
14. If the boring bit has not yet entered the exit trench, complete the following:
  - A. Detach the rod from the drive head.
  - B. Start the engine and back up to the end of the entrance trench.
  - C. Stop engine and wait for all moving parts to stop.
  - D. Connect another rod and repeat steps 11 through 14.

## Reaming the Hole

15. With a shovel, carefully dig around the boring bit clearing it of soil until it can be removed (Fig. 5).
16. Remove the boring bit and attach the reamer (Fig. 5).
17. Attach the cable or piping being installed to the swivel on the end of the reamer (Fig. 5).

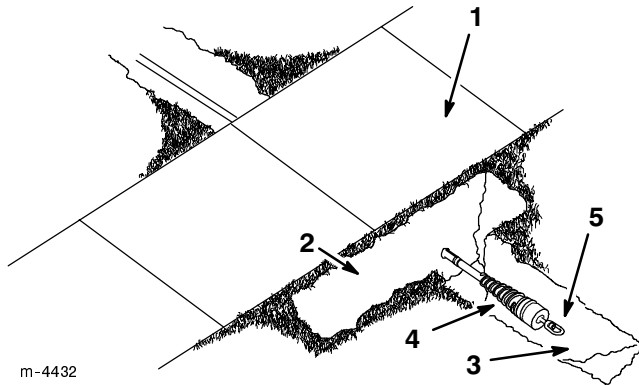

Figure 5

- |                               |           |
|-------------------------------|-----------|
| 1. Sidewalk or driveway       | 4. Reamer |
| 2. Exit trench                | 5. Swivel |
| 3. Shovel dug area around bit |           |

18. Start the engine and pull the auxiliary hydraulics lever rearward to start the reamer.

19. Slowly move the traction unit rearward as the reamer digs into the soil.

**IMPORTANT: Do not drive too fast, forcing the reamer into the soil. Allow the reamer to progress at its own rate. Never push or pull the reamer through the soil when the drive head is not turning.**

20. When a rod coupling is about 6" into the entrance trench or when the reamer completely enters the trench with about 6" of the cable or piping, stop the traction unit, pull the auxiliary hydraulics lever into neutral, and stop engine.

21. If the reamer has not yet entered the exit trench, complete the following:

- A. Detach the rod from the drive head and rod still in the soil.
- B. Start the engine and move to the front of the entrance trench.

C. Stop the engine and wait for all moving parts to stop.

D. Connect the drive head to the rod shaft in the soil.

E. Repeat steps 18 through 21.

22. With the reamer and cable/piping in the entrance trench, remove the cable or piping from the reamer.

## Maintenance



### CAUTION



#### POTENTIAL HAZARD

- If you leave the key in the ignition switch, someone could start the engine.

#### WHAT CAN HAPPEN

- Accidental starting of the engine could seriously injure you or other bystanders.

#### HOW TO AVOID THE HAZARD

- Remove the key from the ignition switch before you do any maintenance.

## Storage

1. Before long term storage, wash the attachment with mild detergent and water to remove dirt and grime.
2. Check the condition of the hydraulic hoses. Replace any damaged hoses.
3. Check and tighten all bolts, nuts, and screws. Repair or replace any part that is damaged or worn.
4. Paint all scratched or bare metal surfaces. Paint is available from your Authorized Service Dealer.
5. Store the attachment in a clean, dry garage or storage area. Cover it to protect it and keep it clean.

# Troubleshooting

PROBLEM	POSSIBLE CAUSES	CORRECTIVE ACTION
Boring drive head will not rotate.	<ol style="list-style-type: none"><li>1. Hydraulic coupler not completely connected</li><li>2. Defective hydraulic coupler</li><li>3. An obstruction in a hydraulic hose</li><li>4. Auxiliary valve on the traction unit is not opening.</li><li>5. Defective hydraulic motor</li></ol>	<ol style="list-style-type: none"><li>1. Check and tighten all couplers.</li><li>2. Check couplers and replace any that are defective.</li><li>3. Find and remove the obstruction.</li><li>4. Repair the valve.</li><li>5. Replace or repair defective motor.</li></ol>

