



Count on it.

Operator's Manual

**Z Master[®] Professional 7000
Series Riding Mower**

**With 132cm or 152cm TURBO FORCE[®]
Mower**

Model No. 72264TE—Serial No. 40000000 and Up

Model No. 72265TE—Serial No. 40000000 and Up

Model No. 72279TE—Serial No. 40000000 and Up

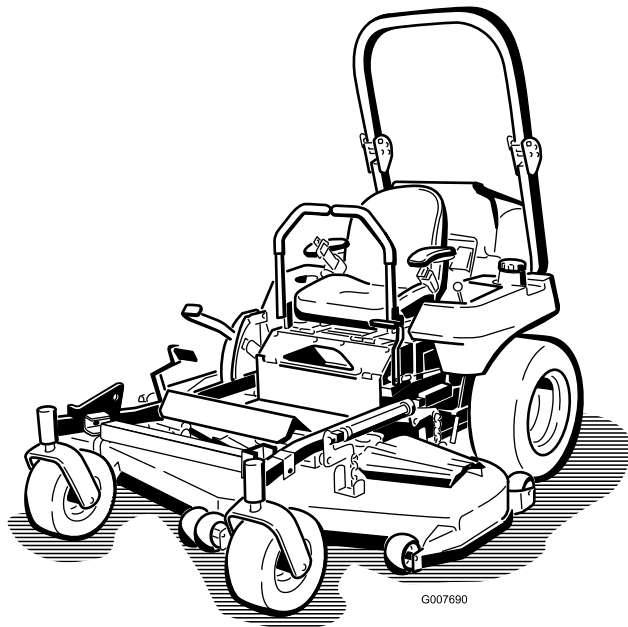

G007690



Operating the Mower Blade-Control Switch (PTO)	25	Checking the Engine-Coolant Level	59
Operating the Throttle	25	Cleaning the Hydraulic-Fluid Cooler and Radiator Screen	60
Starting the Engine in Normal Weather	26	Changing the Engine Coolant	60
Starting the Engine in Cold Weather (Below 23°F or -5°C)	26	Brake Maintenance	61
Shutting Off the Engine	27	Adjusting the Parking Brake	61
Using the Motion-Control Levers	27	Belt Maintenance	61
Driving the Machine	28	Inspecting the Belts	61
Using the Side Discharge	29	Replacing the Mower Belt	61
Adjusting the Height of Cut	29	Replacing the PTO-Drive Belt	64
Adjusting the Anti-Scalp Rollers	30	Replacing the Pump-Drive Belt	65
Adjusting the Skid(s)	31	Replacing and Tensioning the Alternator Belt	65
Adjusting the Flow Baffle Knob	31	Controls System Maintenance	66
Positioning the Flow Baffle	32	Adjusting the Control Handle Neutral Position	66
Operating with the Overheat Sensor	33	Hydraulic System Maintenance	67
Operating Tips	33	Hydraulic System Safety	67
After Operation	34	Hydraulic-Fluid Specifications	67
After Operation Safety	34	Checking the Hydraulic-Fluid Level	67
Using the Fuel-Shutoff Valve	34	Changing the Hydraulic Fluid and Filter	68
Pushing the Machine by Hand	35	Bleeding the Hydraulic System	69
Transporting the Machine	35	Setting the Hydraulic Pump Neutral Position	69
Maintenance	38	Mower Deck Maintenance	71
Maintenance Safety	38	Blade Safety	71
Recommended Maintenance Schedule(s)	39	Servicing the Cutting Blades	71
Pre-Maintenance Procedures	40	Leveling the Mower Deck at 3 Positions	74
Using the Z Stand™	40	Replacing the Grass Deflector	77
Releasing the Mower-Deck Curtain	42	Cleaning	78
Removing the Sheet-Metal Guard	42	Cleaning under the Mower Deck	78
Lubrication	42	Disposing of Waste	78
Greasing the Machine	42	Storage	79
Adding Light Oil or Spray Lubrication	43	Storage Safety	79
Greasing the Mower Deck and Belt Idlers	43	Cleaning and Storage	79
Greasing the Caster Pivots	44	Troubleshooting	80
Greasing the Caster-Wheel Hubs	45	Schematics	82
Engine Maintenance	46		
Engine Safety	46		
Servicing the Air Cleaner	46		
Servicing the Engine Oil	47		
Fuel System Maintenance	51		
Servicing the Fuel Filter and Water Separator	51		
Servicing the Fuel Tank	52		
Electrical System Maintenance	53		
Electrical System Safety	53		
Servicing the Battery	53		
Servicing the Fuses	55		
Drive System Maintenance	55		
Checking the Seat Belt	55		
Adjusting the Tracking	55		
Checking the Tire Pressure	56		
Checking the Wheel Lug Nuts	56		
Torquing the Wheel Hub Castle Nut	56		
Adjusting the Caster-Pivot Bearing	56		
Servicing the Gearbox	57		
Adjusting the Electric Clutch	58		
Cooling System Maintenance	59		

Safety

This machine has been designed in accordance with EN ISO 5395:2013.

Safety Alert Symbol

This Safety Alert Symbol (Figure 2) is used both in this manual and on the machine to identify important safety messages which must be followed to avoid accidents.

This symbol means: **ATTENTION! BECOME ALERT! YOUR SAFETY IS INVOLVED!**



Figure 2
Safety Alert Symbol

g000502

The safety alert symbol appears above information which alerts you to unsafe actions or situations and will be followed by the word **DANGER**, **WARNING**, or **CAUTION**.

DANGER: Indicates an imminently hazardous situation which, if not avoided, **Will** result in death or serious injury.

WARNING: Indicates a potentially hazardous situation which, if not avoided, **Could** result in death or serious injury.

CAUTION: Indicates a potentially hazardous situation which, if not avoided, **May** result in minor or moderate injury.

This manual uses two other words to highlight information. **Important** calls attention to special mechanical information and **Note** emphasizes general information worthy of special attention.

General Safety

This machine is capable of amputating hands and feet and of throwing objects. Toro designed and tested this lawn mower to offer reasonably safe service; however, failure to comply with safety instructions may result in injury or death.

- Read, understand, and follow all instructions and warnings in the Operator's Manual and other training material, on the machine, engine, and attachments. All operators and mechanics should be trained. If the operator(s) or mechanic(s) can not read this manual, it is the owner's responsibility to explain this material to them; other languages may be available on our website.
- Only allow trained, responsible, and physically capable operators that are familiar with the safe operation, operator controls, and safety signs and instructions to operate the machine. Never let children or untrained people operate or service the equipment. Local regulations may restrict the age of the operator.
- Always keep the roll bar in the fully raised and locked position and use the seat belt.
- Do not operate the machine near drop-offs, ditches, embankments, water, or other hazards, or on slopes greater than 15 degrees.
- Do not put your hands or feet near moving components of the machine.
- Never operate the machine with damaged guards, shields, or covers. Always have safety shields, guards, switches and other devices in place and in proper working condition.
- Stop the machine, shut off the engine, and remove the key before servicing, fueling, or unclogging the machine.

Slope Indicator

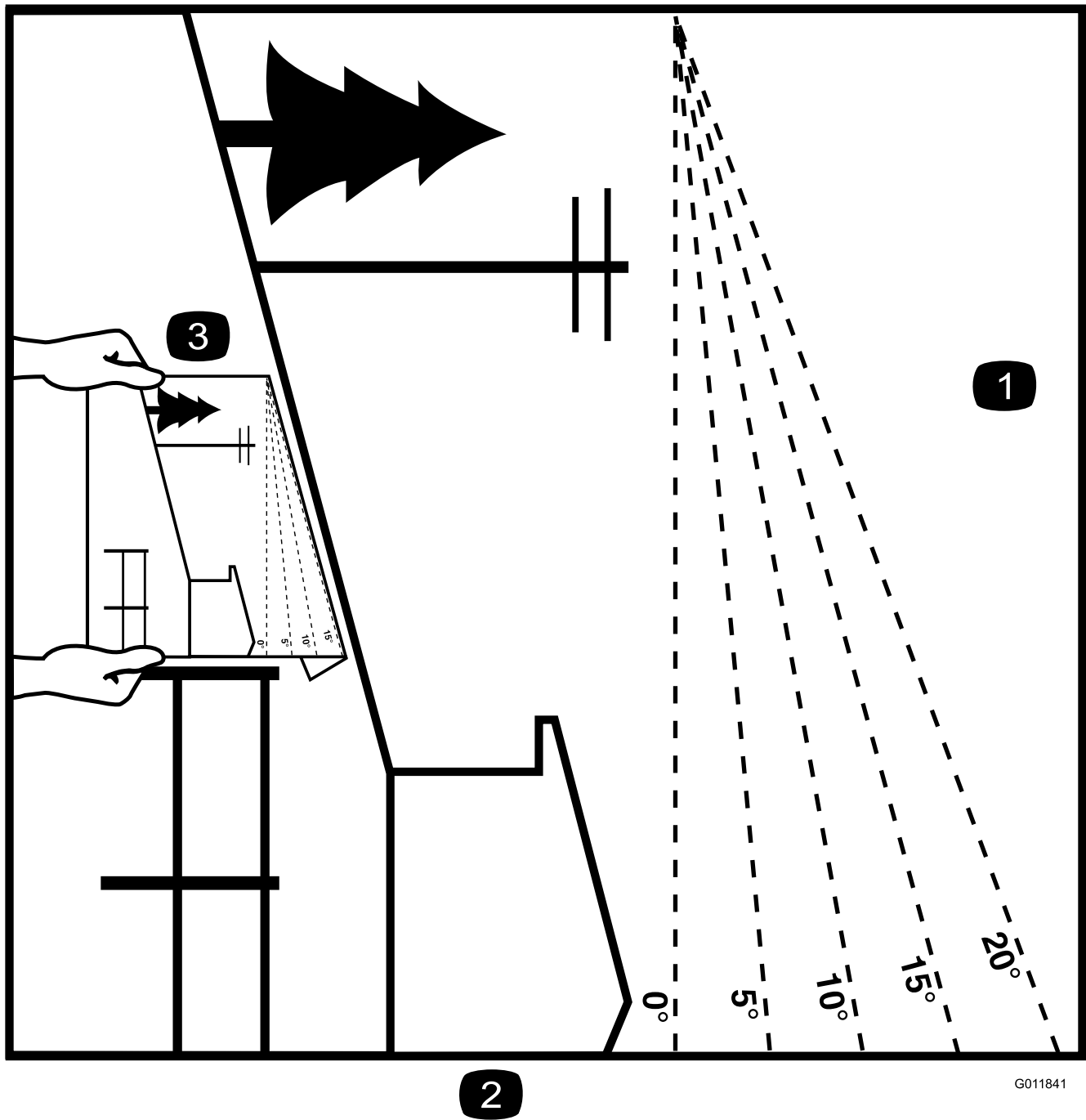

G011841

g011841

Figure 3

You may copy this page for personal use.

1. The maximum slope you can operate the machine on is **15 degrees**. Use the slope chart to determine the degree of slope of hills before operating. **Do not operate this machine on a slope greater than 15 degrees**. Fold along the appropriate line to match the recommended slope.
2. Align this edge with a vertical surface, a tree, building, fence pole, etc.
3. Example of how to compare slope with folded edge

Safety and Instructional Decals



Safety decals and instructions are easily visible to the operator and are located near any area of potential danger. Replace any decal that is damaged or missing.



Battery Symbols

Some or all of these symbols are on your battery.

- | | |
|--|---|
| 1. Explosion hazard | 6. Keep bystanders away from the battery. |
| 2. No fire, open flame, or smoking | 7. Wear eye protection; explosive gases can cause blindness and other injuries. |
| 3. Caustic liquid/chemical burn hazard | 8. Battery acid can cause blindness or severe burns. |
| 4. Wear eye protection. | 9. Flush eyes immediately with water and get medical help fast. |
| 5. Read the <i>Operator's Manual</i> . | 10. Contains lead; do not discard |



93-7010

decal93-7010

1. Thrown object hazard—keep bystanders away.
2. Thrown object hazard, mower—keep the deflector in place.
3. Cutting/dismemberment hazard of hand or foot, mower blade—stay away from moving parts.

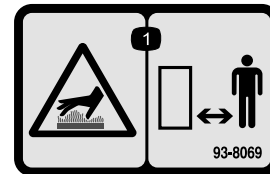

93-8069

decal93-8069

1. Hot surface/burn hazard—stay a safe distance away from the hot surface.



Manufacturer's Mark

decaloemark

1. Indicates the blade is identified as a part from the original machine manufacturer.

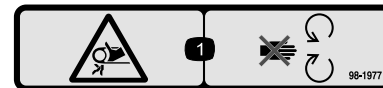

98-1977

decal98-1977

1. Entanglement hazard, belt—stay away from moving parts.



58-6520

decal58-6520

1. Grease



98-4387

decal98-4387

1. Warning—wear hearing protection.

Side Discharge Machines Only

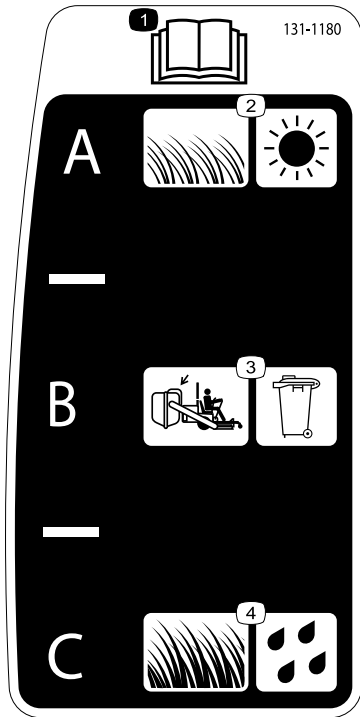

131-1180

decal131-1180

- | | |
|--|--------------------------------------|
| 1. Read the <i>Operator's Manual</i> . | 3. Bagging setting |
| 2. Short, light grass; dry conditions | 4. Tall, dense grass; wet conditions |

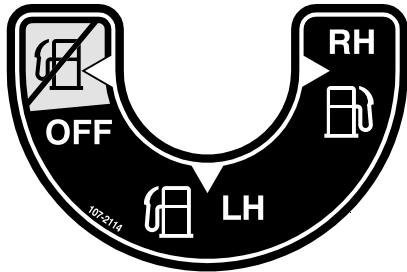

107-2114

decal107-2114

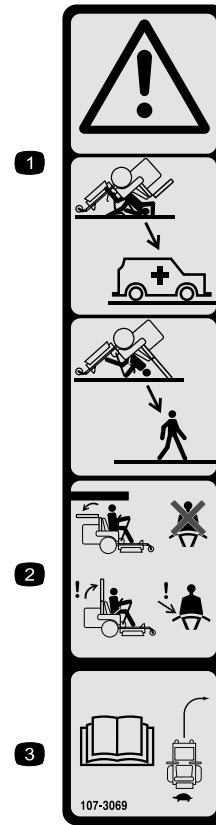

107-3069

decal107-3069

1. Warning—there is no rollover protection when the roll bar is down.
2. To avoid injury or death from a rollover accident, keep the roll bar in the raised and locked position and wear the seat belt. Lower the roll bar only when absolutely necessary; do not wear the seat belt when the roll bar is down.
3. Read the *Operator's Manual*; drive slowly and carefully.



133-8062

decal133-8062

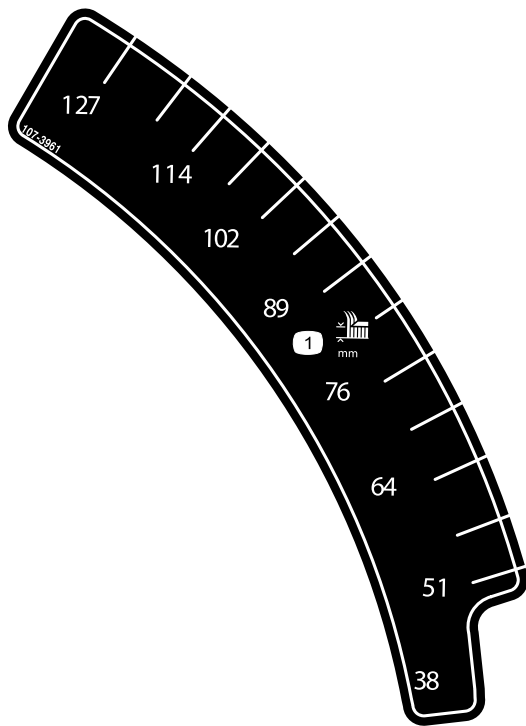

107-3961

decal107-3961

1. Height of cut in millimeters

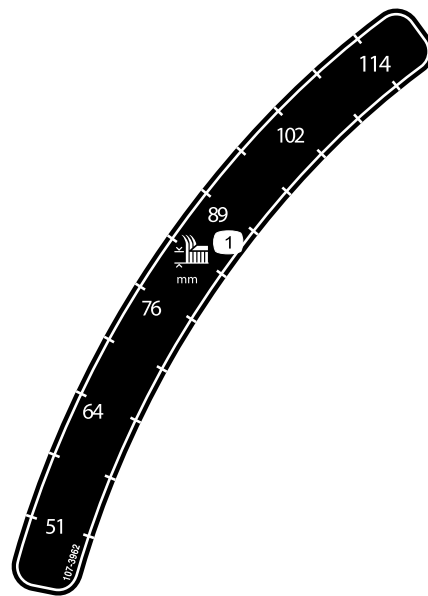

107-3962

decal107-3962

1. Height of cut in millimeters

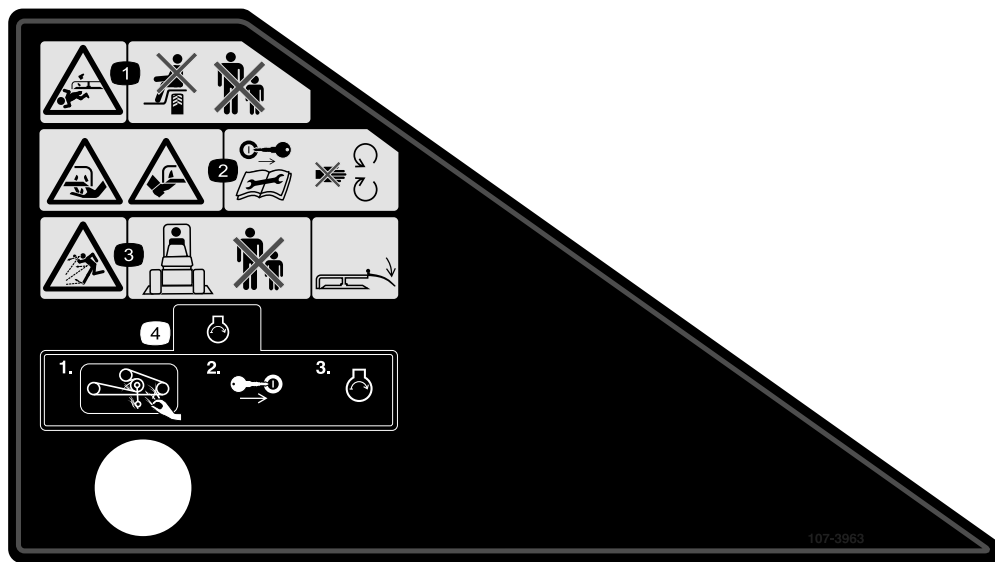

107-3963

decal107-3963

1. Cutting/dismemberment hazard, mower blade—do not carry passengers and keep bystanders away.
2. Cutting/dismemberment hazard of hand or foot, mower blade—remove the key and read the instructions before servicing or performing maintenance; stay away from moving parts.
3. Thrown object hazard—keep bystanders away; keep the deflector in place.
4. Before starting the engine, clean grass and debris from the mower belt and pulleys, insert the key, and start the engine.

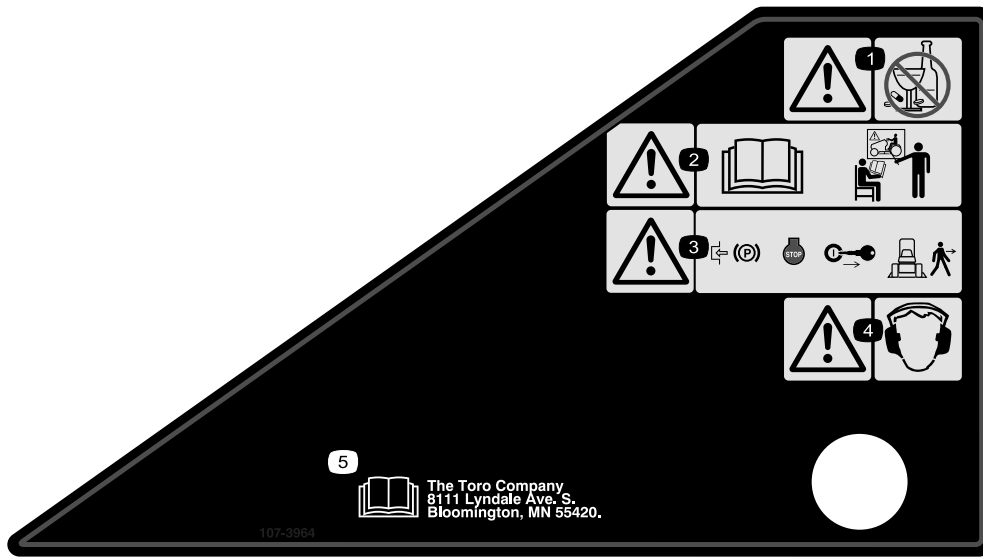

107-3964

decal107-3964

1. Warning—do not use drugs or alcohol.
2. Warning—read the *Operator's Manual* and receive training.
3. Warning—engage the parking brake, shut off the engine, and remove the key before leaving the machine.
4. Warning—wear hearing protection.
5. Read the *Operator's Manual*.

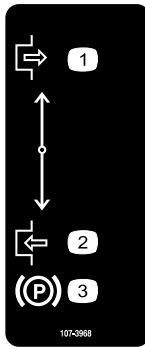

107-3968

decal107-3968

1. Disengage
2. Engage
3. Parking brake

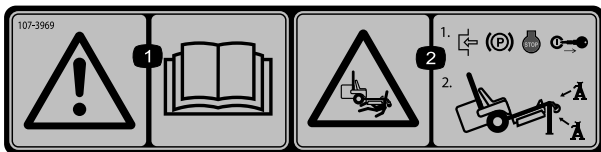

107-3969

decal107-3969

1. Warning—read the *Operator's Manual*.
2. Crushing hazard, mower—engage the parking brake, shut off the engine, and remove the key before working under the mower.

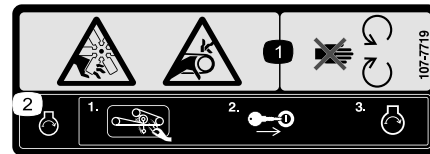

107-7719

decal107-7719

1. Cutting/dismemberment hazard, fan and entanglement hazard, belt—stay away from moving parts.
2. Before starting the engine, clean grass and debris from the mower belt and pulleys, insert the key, and start the engine.

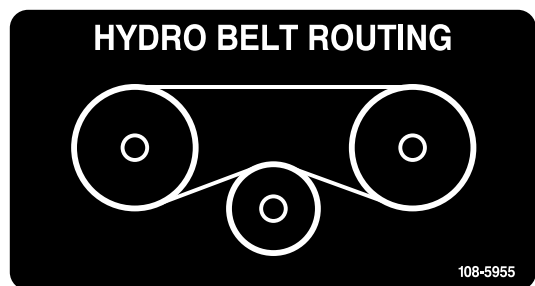

108-5955

decal108-5955

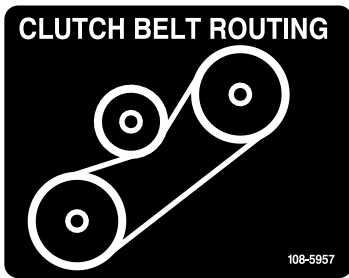

108-5957

decal108-5957

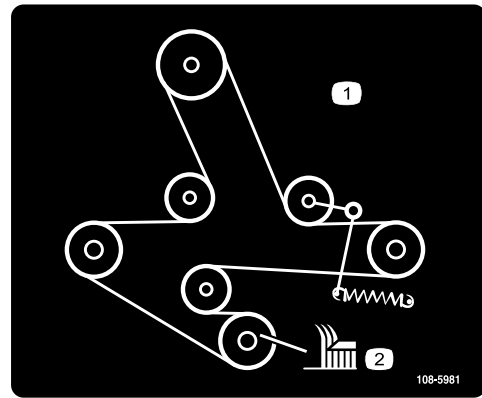

108-5981

decal108-5981

1. Belt routing

2. Height of cut

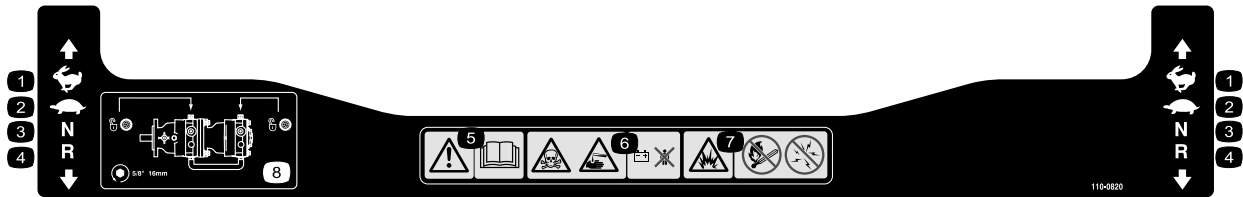

110-0820

decal110-0820

1. Fast
2. Slow
3. Neutral
4. Reverse

5. Warning—read the *Operator's Manual*.
6. Poison and caustic liquid/chemical burn hazard—keep children away from the battery.
7. Explosion hazard—no fire, open flames, or smoking; avoid sparks.
8. To unlock the traction drive, turn the bypass valve 1 complete revolution counterclockwise using a 5/8 inch or 16 mm wrench.

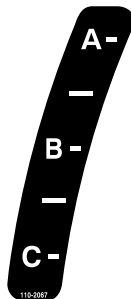

110-2067

decal110-2067

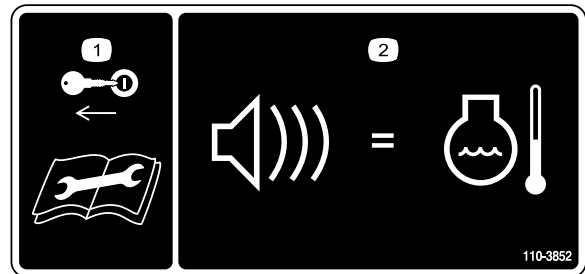

110-3852

decal110-3852

1. Remove the key and read the instructions before servicing or performing maintenance.
2. Continuous tone signals the user that engine is overheating.

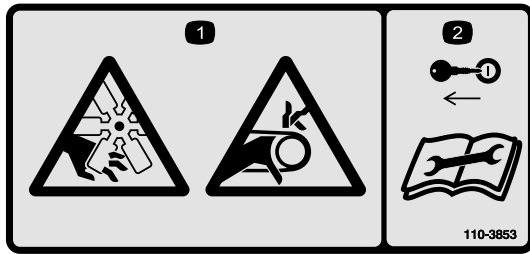

110-3853

decal110-3853

1. Cutting/dismemberment hazard, fan and entanglement hazard, belt.
2. Remove the key from the key switch and read the instructions before servicing or performing maintenance.

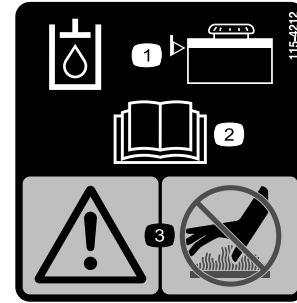

115-4212

decal115-4212

1. Hydraulic fluid level
2. Read the *Operator's Manual*.
3. Warning—do not touch the hot surface.

Rear Discharge Machines Only

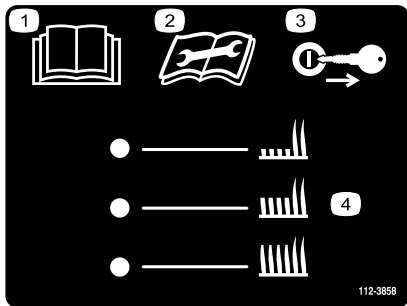

112-3858

decal112-3858

1. Read the *Operator's Manual*.
2. Read the *Operator's Manual* before performing maintenance.
3. Remove the key before adjusting the height of cut.
4. Height-of-cut settings

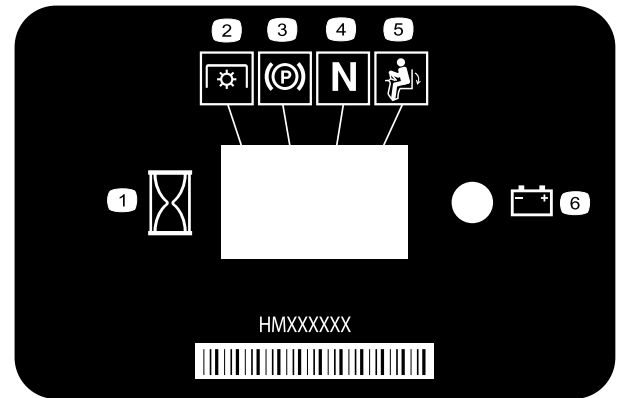

116-5610

decal116-5610

1. Hour meter
2. Power take-off (PTO)
3. Parking brake
4. Neutral
5. Operator presence switch
6. Battery

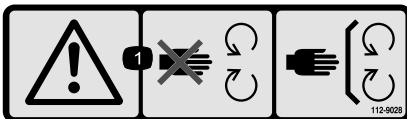

112-9028

decal112-9028

1. Warning—stay away from moving parts; keep all guards and shields in place.

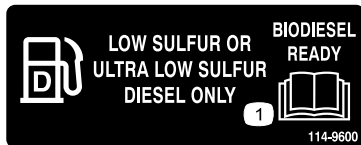

114-9600

decal114-9600

1. Read the *Operator's Manual*.

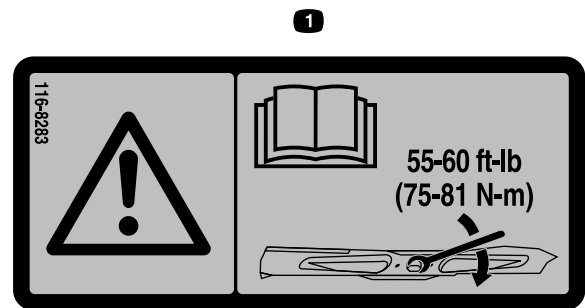

116-8283

decal116-8283

1. Warning—read the *Operator's Manual* for instructions on torquing the blade bolt/nut to 75 to 81 N-m (55 to 60 ft-lb).

Rear Discharge Machines Only



117-3848

decal117-3848

1. Thrown object hazard—keep bystanders away.
2. Thrown object hazard, raised deflector—do not operate without the deflector, discharge cover, or grass collection system in place.
3. Cutting/dismemberment hazard of hand or foot, mower blade—stay away from moving parts; keep all guards and shields in place.



119-0397

decal119-0397

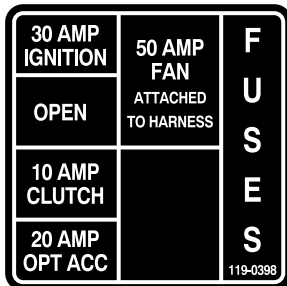

119-0398

decal119-0398

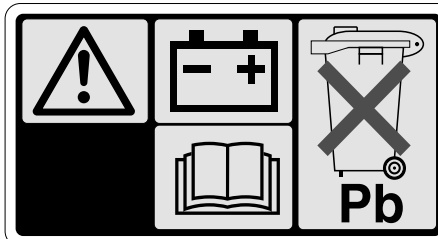

107-9309

1. Warning—read the *Operator's Manual* for information on charging the battery; contains lead; do not discard.
2. Read the *Operator's Manual*.

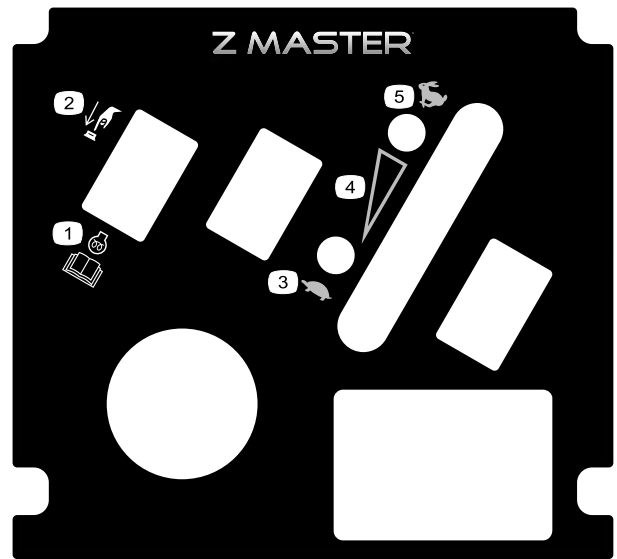

121-7562

decal121-7562

1. Push to start
2. Read the *Operator's Manual* for more information on preheating the engine.
3. Slow
4. Variable speed control
5. Fast



126-2055

decal126-2055

1. Wheel lug nut—torque to 129 N·m (95 ft·lb).
2. Wheel hub nut—torque to 319 N·m (235 ft·lb).
3. Read the *Operator's Manual* before performing maintenance; check the torque after the first 100 hours and every 500 hours after.

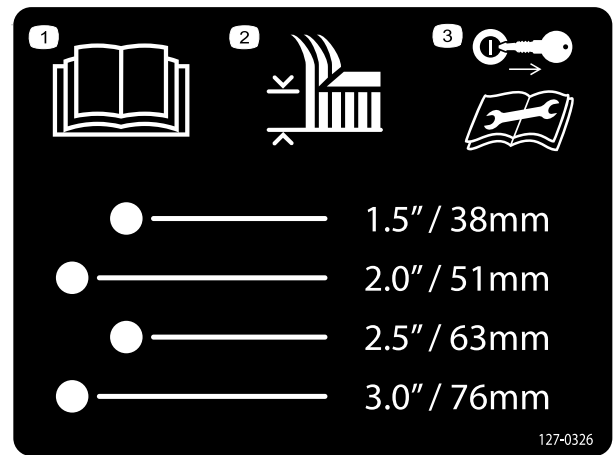

127-0326

decal127-0326

127-0326

1. Read the *Operator's Manual*.
2. Height of cut
3. Remove the key and read the *Operator's Manual* before performing maintenance.



132-0871

132-0871

decal132-0871

Note: This machine complies with the industry standard stability test in the static lateral and longitudinal tests with the maximum recommended slope indicated on the decal. Review the instructions for operating the machine on slopes in the *Operator's Manual* as well as the conditions in which you would operate the machine to determine whether you can operate the machine in the conditions on that day and at that site. Changes in the terrain can result in a change in slope operation for the machine.

1. Warning—read the *Operator's Manual*; all operators should be trained before operating the machine; wear hearing protection.
2. Cutting/dismemberment hazard of hand—stay away from moving parts; keep all guards and shields in place.
3. Thrown object hazard—keep bystanders away.
4. Tipping hazard—do not use dual ramps when loading onto a trailer; use 1 ramp wide enough for the machine; use a ramp with a slope less than 15°; back up the ramp (in reverse) and drive forward off the ramp.
5. Runover hazard—do not carry passengers; look behind you when moving in reverse.
6. Tipping hazard—do not use the machine near drop-offs or on slopes greater than 15°; only operate across slopes less than 15°.

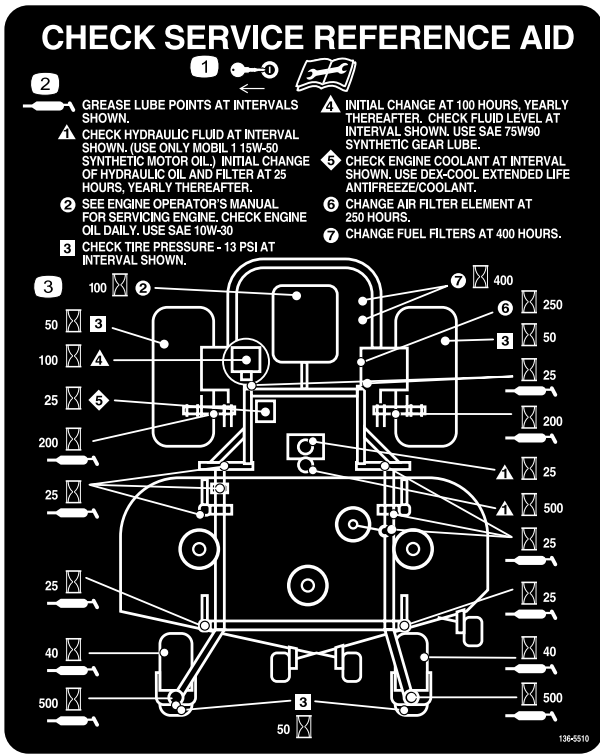

136-5510
Side Discharge Machines Only

1. Remove the key and read the *Operator's Manual* before performing maintenance.
2. Grease point
3. Hour interval

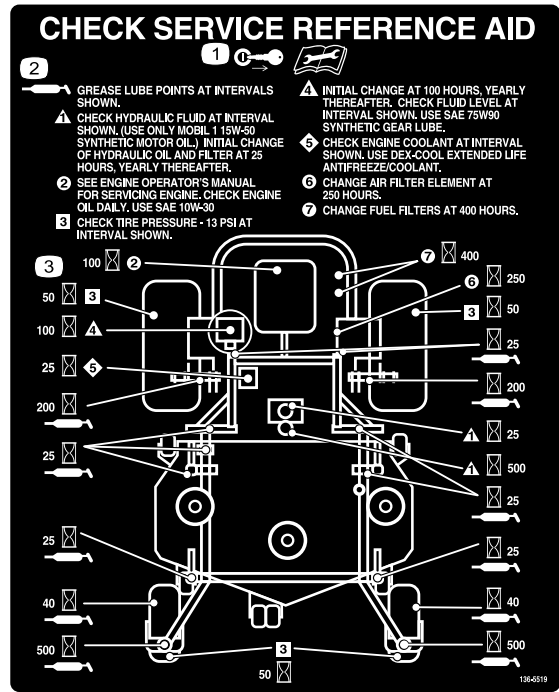

136-5519
Rear Discharge Machines Only

1. Remove the key and read the *Operator's Manual* before performing maintenance.
2. Grease point
3. Hour interval

Product Overview

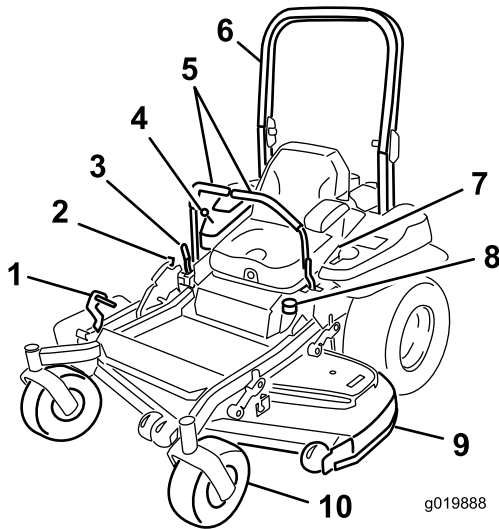

Figure 4
Side Discharge Machine

- | | |
|----------------------------------|------------------|
| 1. Height-of-cut deck lift pedal | 6. Roll bar |
| 2. Transport lock | 7. Seat belt |
| 3. Parking-brake lever | 8. Fuel cap |
| 4. Controls | 9. Mower deck |
| 5. Motion-control lever | 10. Caster wheel |

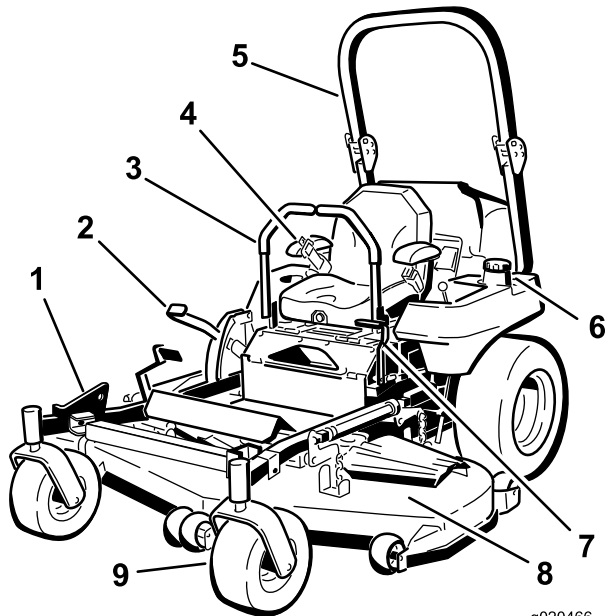

Figure 5
Rear Discharge Machine

- | | |
|-------------------------|--------------------------|
| 1. Z Stand® | 6. Fuel cap (both sides) |
| 2. Height-of-cut lever | 7. Parking-brake lever |
| 3. Motion-control lever | 8. Mower deck |
| 4. Seat belt | 9. Caster wheel |
| 5. Roll bar | |

Controls

Become familiar with all the controls before you start the engine and operate the machine.

Control Panel

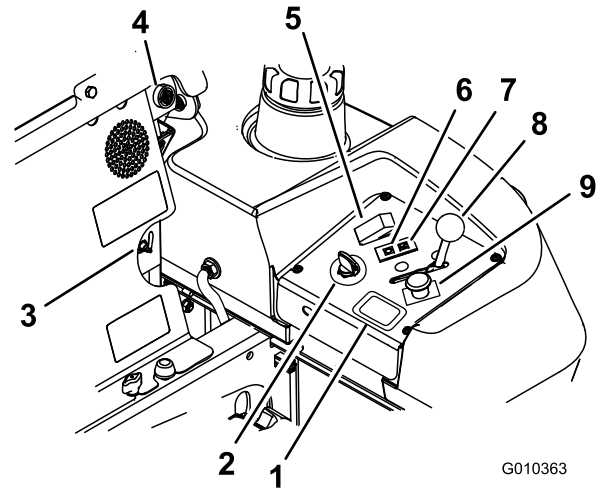

Figure 6

- | | |
|------------------------|-----------------------------|
| 1. Hour meter | 6. Glow-plug light |
| 2. Key switch | 7. Engine-temperature light |
| 3. Fuel-selector valve | 8. Throttle control |
| 4. Audible alarm | 9. PTO switch |
| 5. Glow-plug switch | |

Key Switch

The key switch, used to start and shut off the engine, has 3 positions: OFF, RUN, and START. Refer to [Starting the Engine in Normal Weather \(page 26\)](#).

Throttle Control

The throttle controls the engine speed, and it has a continuous-variable setting from the SLOW to FAST position ([Figure 6](#)).

Blade-Control Switch (Power Takeoff)

The blade-control switch, represented by a power-takeoff (PTO) symbol, engages and disengages power to the mower blades ([Figure 6](#)).

Hour Meter

The hour meter records the number of hours the engine has operated. It operates when the engine is running. Use these times for scheduling regular maintenance (Figure 7).

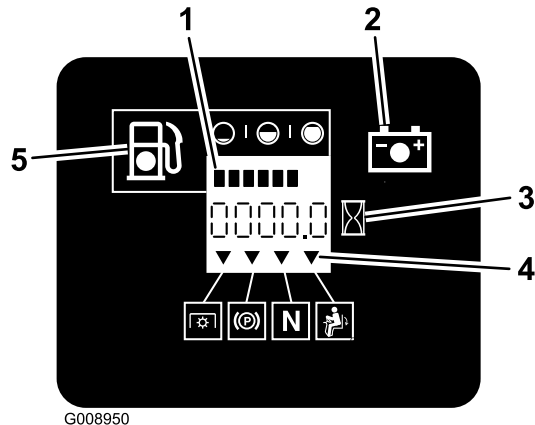

Figure 7

- | | |
|----------------------|-----------------------------|
| 1. Fuel gauge (bars) | 4. Safety-interlock symbols |
| 2. Battery light | 5. Low fuel indicator light |
| 3. Hour meter | |

Safety-Interlock Indicators

There are symbols on the hour meter that indicate with a black triangle that the interlock component is positioned correctly (Figure 7).

Battery-Indicator Light

If you turn the key switch to the ON position for a few seconds, the battery voltage displays in the area where the hours are normally displayed.

The battery light turns on when the key switch is turned on and when the charge is below the correct operating level (Figure 7).

Glow-Plug Light

The glow-plug indicator light turns on when the glow-plug button is engaged (Figure 6).

Glow-Plug Switch

This switch activates the glow plugs and is indicated by the glow-plug light. Hold down the glow-plug switch for 10 seconds prior to starting the machine.

Temperature Light

The temperature light comes on when the engine is overheating (Figure 6).

Audible Alarm

This machine has an audible alarm that alerts the user to shut off the engine; otherwise, engine damage can occur from over heating. Refer to [Operating with the Overheat Sensor](#) (page 33).

Motion-Control Levers

Use the motion-control levers to drive the machine forward, reverse, and turn either direction (Figure 4).

Fuel-Selector Valve

The fuel-selector valve is located behind the seat.

Close the fuel-selector valve when transporting or storing the machine.

Move the selector valve to the left or right position for operation.

Neutral-Lock Position

Move the motion-control levers outward from the center to the NEUTRAL-LOCK position when exiting the machine (Figure 25). Always position the motion-control levers into the NEUTRAL-LOCK position when you stop the machine or leave it unattended.

Parking-Brake Lever

Whenever you shut off the engine, engage the parking brake to prevent accidental movement of the machine.

Attachments/Accessories

A selection of Toro approved attachments and accessories is available for use with the machine to enhance and expand its capabilities. Contact your Authorized Service Dealer or authorized Toro distributor or go to www.Toro.com for a list of all approved attachments and accessories.

To ensure optimum performance and continued safety certification of the machine, use only genuine Toro replacement parts and accessories. Replacement parts and accessories made by other manufacturers could be dangerous, and such use could void the product warranty.

Operation

Note: Determine the left and right sides of the machine from the normal operating position.

Before Operation

Before Operation Safety

General Safety

- Evaluate the terrain to determine what accessories and attachments are needed to properly and safely perform the job. Only use accessories and attachments approved by Toro.
- Inspect the area where the equipment is to be used and remove all rocks, toys, sticks, wires, bones, and other foreign objects. These can be thrown or interfere with the operation of the machine and may cause personal injury to the operator or bystanders.
- Wear appropriate personal protective equipment such as safety glasses, substantial slip-resistant footwear, and hearing protection. Tie back long hair and avoid loose clothing and loose jewelry which may get tangled in moving parts.

⚠ CAUTION

This machine produces sound levels in excess of 85 dBA at the operator's ear and can cause hearing loss through extended periods of exposure.

Wear hearing protection when operating this machine.

- Check that the operator presence controls, safety switches, and shields are attached and functioning properly. Do not operate unless they are functioning properly.
- Do not operate the mower when people, especially children, or pets are in the area. Stop the machine and attachment(s) if anyone enters the area.
- Do not operate the machine without the entire grass collection system, discharge deflector, or other safety devices in place and in proper working condition. Grass catcher components are subject to wear, damage and deterioration, which could expose moving parts or allow objects to be thrown. Frequently check for worn or deteriorating components and replace them with the manufacturer's recommended parts when necessary.

Fuel Safety

Use extreme care when handling fuel.

⚠ DANGER

In certain conditions fuel is extremely flammable and vapors are explosive.

A fire or explosion from fuel can burn you, others, and cause property damage.

- **Fill the fuel tank outdoors on level ground, in an open area, when the engine is cold. Wipe up any fuel that spills.**
- **Never refill the fuel tank or drain the machine indoors or inside an enclosed trailer.**
- **Do Not fill the fuel tank completely full. Fill the fuel tank to the bottom of the filler neck. The empty space in the tank allows fuel to expand. Overfilling may result in fuel leakage or damage to the engine or emission system.**
- **Never smoke when handling fuel, and stay away from an open flame or where fuel fumes may be ignited by spark.**
- **Store fuel in an approved container and keep it out of the reach of children.**
- **Add fuel before starting the engine. Never remove the cap of the fuel tank or add fuel when engine is running or when the engine is hot.**
- **If fuel is spilled, Do Not attempt to start the engine. Move away from the area of the spill and avoid creating any source of ignition until fuel vapors have dissipated.**
- **Do Not operate without entire exhaust system in place and in proper working condition.**

⚠ DANGER

In certain conditions during fueling, static electricity can be released causing a spark which can ignite fuel vapors. A fire or explosion from fuel can burn you and others and cause property damage.

- Always place fuel containers on the ground away from your vehicle before filling.
- Do Not fill fuel containers inside a vehicle or on a truck or trailer bed because interior carpets or plastic truck bed liners may insulate the container and slow the loss of any static charge.
- When practical, remove gas-powered equipment from the truck or trailer and refuel the equipment with its wheels on the ground.
- If this is not possible, then refuel such equipment on a truck or trailer from a portable container, rather than from a fuel dispenser nozzle.
- If a fuel dispenser nozzle must be used, keep the nozzle in contact with the rim of the fuel tank or container opening at all times until fueling is complete. Do Not use a nozzle lock open device.

⚠ WARNING

Fuel is harmful or fatal if swallowed. Long-term exposure to vapors has caused cancer in laboratory animals. Failure to use caution may cause serious injury or illness.

- Avoid prolonged breathing of vapors.
- Keep face away from nozzle and gas tank/container opening.
- Keep away from eyes and skin.
- Never siphon by mouth.

⚠ CAUTION

Fuel tank vent is located inside the roll bar tube. Removing or modifying the roll bar could result in fuel leakage and violate emissions regulations.

- Do Not remove roll bar.
- Do Not weld, drill, or modify roll bar in any way.

To help prevent fires:

- Keep engine and engine area free from accumulation of grass, leaves, excessive grease or oil, and other debris which can accumulate in these areas.
- Clean up oil and fuel spills and remove fuel soaked debris.
- Allow the machine to cool before storing the machine in any enclosure. Do Not store near flame or any enclosed area where open pilot lights or heat appliances are present.

Performing Daily Maintenance

Before starting the machine each day, perform the Each Use/Daily procedures listed in [Maintenance \(page 38\)](#).

Adding Fuel

Recommended Fuel

The engine runs on clean, fresh diesel fuel with a minimum octane rating of 40. Purchase fuel in quantities that can be used within 30 days to ensure fuel freshness.

Use summer-grade diesel fuel (No. 2-D) at temperatures above -7°C (20°F) and winter-grade diesel fuel (No. 1-D or No. 1-D/2-D blend) below -7°C (20°F). Use of winter-grade diesel fuel at lower temperatures provides lower flash point and pour point characteristics, therefore easing startability and lessening chances of chemical separation of the fuel due to lower temperatures (wax appearance, which may plug filters).

Using summer-grade diesel fuel above -7°C (20°F) contributes toward longer life of the pump components.

Important: Do not use kerosene or gasoline instead of diesel fuel. Failure to observe this caution will damage the engine.

Biodiesel Ready

This machine can also use a biodiesel blended fuel of up to B20 (20% biodiesel, 80% petrodiesel). The petrodiesel portion should be low or ultra low sulfur.

Observe the following precautions:

- The biodiesel portion of the fuel meet specification ASTM D6751 or EN14214.
- The blended fuel composition should meet ASTM D975 or EN590.

- Painted surfaces may be damaged by biodiesel blends.
- Use B5 (biodiesel content of 5%) or lesser blend in cold weather.
- Monitor seals, hoses, gaskets in contact with fuel as they may degrade over time.
- Fuel filter plugging may be expected for a time after converting to biodiesel blends.
- Contact your distributor for more information on biodiesel.

Filling the Fuel Tank

1. Park the machine on a level surface.
2. Engage the parking brake.
3. Shut off the engine and remove the key.
4. Clean around the fuel-tank cap.
5. Fill the fuel tank to the bottom of the filler neck (Figure 8).

Note: Do not fill the fuel tank completely full. The empty space in the tank allows the fuel to expand.

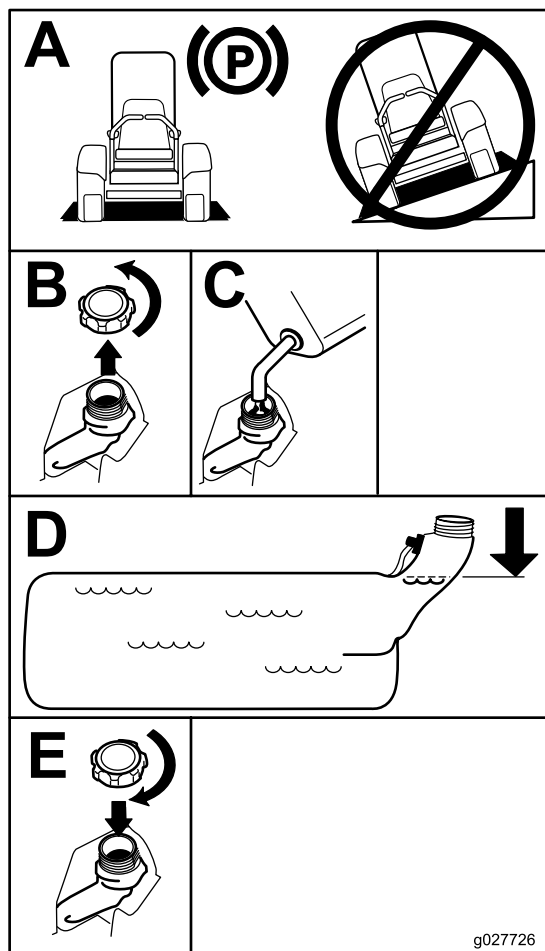

Figure 8

g027726

Switching the Fuel Tanks

Important: Do not allow the machine to run out of fuel, as this can damage the machine.

The fuel-selector valve is located behind the left side of the seat.

The machine has 2 fuel tanks: 1 tank is on the left side and 1 is on the right side. Each tank connects to the fuel-selector valve. From there, a common fuel line leads to the engine (Figure 9).

To use the left fuel tank, rotate the fuel-selector valve to the left. To use the right fuel tank, rotate the fuel-selector valve to the right (Figure 9).

Close the fuel-selector valve before transporting or storing the machine.

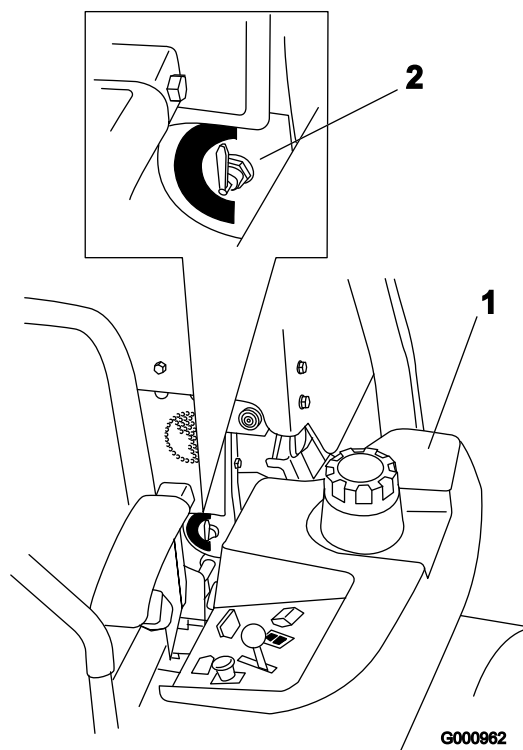

Figure 9

1. Left fuel tank
2. Fuel-selector valve

Breaking in a New Machine

New engines take time to develop full power. Mower decks and drive systems have higher friction when new, placing additional load on the engine. Allow 40 to 50 hours of break-in time for new machines to develop full power and best performance.

Using the Rollover-Protection System (ROPS)

⚠ WARNING

To avoid injury or death from rollover, keep the roll bar in the fully raised, locked position and use the seat belt.

Ensure that the seat is secured to the machine.

⚠ WARNING

There is no rollover protection when the roll bar is in the down position.

- Lower the roll bar only when absolutely necessary.
- Do not wear the seat belt when the roll bar is in the down position.
- Drive slowly and carefully.
- Raise the roll bar as soon as clearance permits.
- Check carefully for overhead clearances (i.e., branches, doorways, electrical wires) before driving under any objects and do not contact them.

Lowering the Roll Bar

Important: Lower the roll bar only when absolutely necessary.

1. Remove the hairpin cotters and remove the 2 pins (Figure 11).
2. Lower the roll bar to the down position (Figure 10).

Note: There are 2 down positions; refer to Figure 10.

3. Install the 2 pins and secure them with the hairpin cotters (Figure 11).

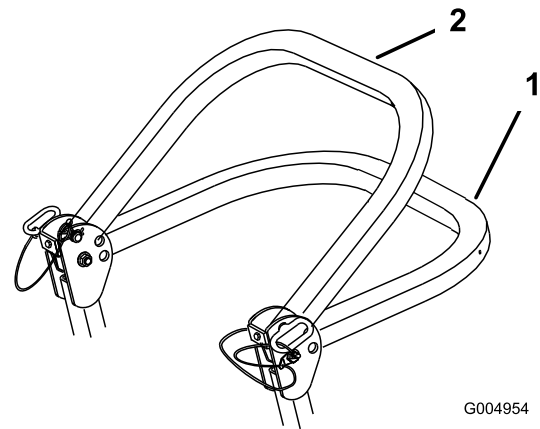

G004954

g004954

Figure 10

1. Full-down position
2. Down position with the bagger installed

Important: Ensure that you secure the rear part of the seat with the seat latch.

Raising the Roll Bar

Important: Always use the seat belt with the roll bar in the raised position.

1. Remove the hairpin cotters and remove the 2 pins (Figure 11).
2. Raise the roll bar to the upright position, install the 2 pins, and secure them with the hairpin cotters (Figure 11).

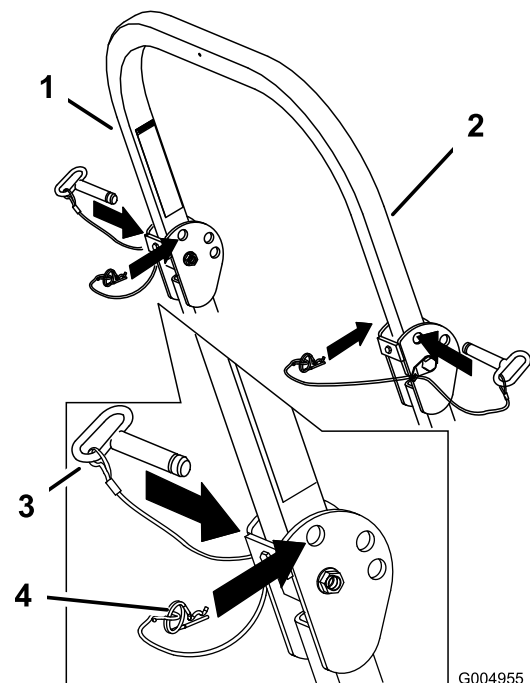

G004955

g004955

Figure 11

1. Roll bar
2. Raised position
3. Pin
4. Hairpin cotter

Using the Safety-Interlock System

⚠ WARNING

If the safety-interlock switches are disconnected or damaged, the machine could operate unexpectedly, causing personal injury.

- Do not tamper with the interlock switches.
- Check the operation of the interlock switches daily and replace any damaged switches before operating the machine.

Understanding the Safety-Interlock System

The safety-interlock system is designed to prevent the engine from starting unless the following occurs:

- The parking brake is engaged.
- The blade-control switch (PTO) is disengaged.
- The motion-control levers are in the NEUTRAL-LOCK position.

The safety-interlock system also is designed to shut off the engine when the motion-control levers are moved from the NEUTRAL-LOCK position with the parking brake engaged or if you rise from the seat when the PTO is engaged.

The hour meter has indicators to notify the user when the interlock component is in the correct position. When the component is in the correct position, an indicator displays on the screen.

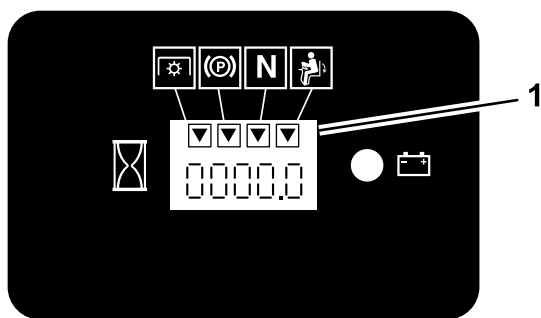

Figure 12

1. Indicators display when the interlock components are in the correct position

Testing the Safety-Interlock System

Service Interval: Before each use or daily

Test the safety-interlock system before you use the machine each time. If the safety system does not operate as described below, have an Authorized Service Dealer repair the safety system immediately.

1. Sit on the seat, engage the parking brake, and move the blade-control switch (PTO) to the ON position. Try starting the engine; the engine should not start.
2. Sit on the seat, engage the parking brake, and move the blade-control switch (PTO) to the OFF position. Move either motion-control lever out of the NEUTRAL-LOCK position. Try starting the engine; the engine should not start. Repeat for the other control lever.
3. Sit on the seat, engage the parking brake, move the blade-control switch (PTO) to the OFF position, and move the motion-control levers to the NEUTRAL-LOCK position. Now start the engine. While the engine is running, disengage the parking brake, engage the blade-control switch (PTO), and rise slightly from the seat; the engine should shut off.
4. Sit on the seat, engage the parking brake, move the blade-control switch (PTO) to the OFF position, and move the motion-control levers to the NEUTRAL-LOCK position. Now start the engine. While the engine is running, center either motion control and move (forward or reverse); the engine should shut off. Repeat for other motion control.
5. Sit on the seat, disengage the parking brake, move the blade-control switch (PTO) to the OFF position, and move the motion-control levers to the NEUTRAL-LOCK position. Try starting the engine; the engine should not start.

Positioning the Seat

The seat can move forward and backward. Position the seat where you have the best control of the machine and are most comfortable (Figure 13).

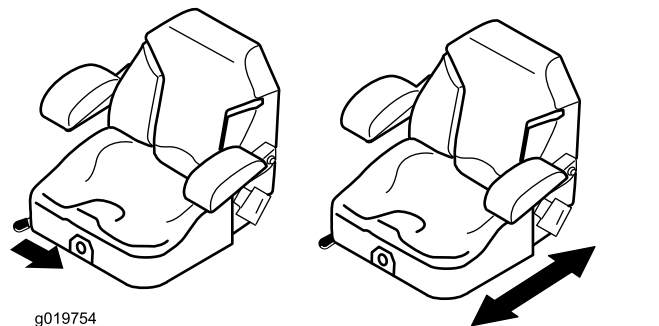

Figure 13

Unlatching the Seat

1. Move the seat to the most rearward position.
Note: This prevents interference when you raise the seat.
2. Push the seat latch rearward to unlatch the seat.
3. Raise the seat up (Figure 14).

Note: This allows access to the machine under the seat.

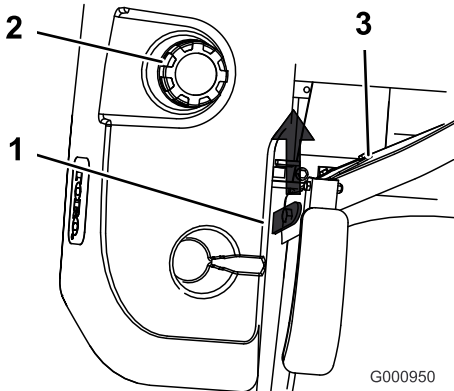

Figure 14

1. Seat latch
2. Fuel cap
3. Seat

Changing the Seat Suspension

The seat is adjustable to provide a smooth and comfortable ride. Position the seat where you are most comfortable.

To adjust it, turn the knob in front either direction to provide the best comfort (Figure 15).

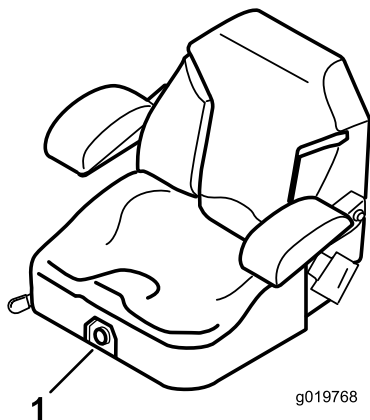

Figure 15

1. Seat-suspension knob

During Operation

During Operation Safety

General Safety

The operator must use their full attention when operating the machine. **Do Not** engage in any activity that causes distractions; otherwise, injury or property damage may occur.

⚠ WARNING

Operating engine parts, especially the muffler, become extremely hot. Severe burns can occur on contact and debris, such as leaves, grass, brush, etc. can catch fire.

- Allow engine parts, especially the muffler, to cool before touching.
- Remove accumulated debris from muffler and engine area.

⚠ WARNING

Engine exhaust contains carbon monoxide, which is an odorless deadly poison that can kill you.

Do Not run engine indoors or in a small confined area where dangerous carbon monoxide fumes can collect.

- The owner/user can prevent and is responsible for accidents or injuries occurring to himself or herself, other people or property.
- This mower was designed for one operator only. Do not carry passengers and keep all others away from machine during operation.
- Do Not operate the machine under the influence of alcohol or drugs.
- Operate only in daylight or good artificial light.
- Lightning can cause severe injury or death. If lightning is seen or thunder is heard in the area, Do Not operate the machine; seek shelter.
- Use extra care while operating with accessories or attachments, such as grass collection systems. These can change the stability of the machine and cause a loss of control. Follow directions for counter weights if required.
- Keep away from holes, ruts, bumps, rocks, and other hidden hazards. Use care when approaching blind corners, shrubs, trees, tall grass or other objects that may hide obstacles or obscure vision. Uneven terrain could overturn the machine or cause the operator to lose their balance or footing.

- Be sure all drives are in neutral and parking brake is engaged before starting engine. Use seat belts with the roll bar in the raised and locked position.
- Start the engine carefully according to instructions with feet well away from the blades.
- Never operate the mower with damaged guards, shields, or covers. Always have safety shields, guards, switches and other devices in place and in proper working condition.
- Keep clear of the discharge opening at all times. Never mow with the discharge door raised, removed or altered unless there is a grass collection system or mulch kit in place and working properly.
- Keep hands and feet away from moving parts. If possible, Do Not make adjustments with the engine running.
- Whenever you leave the mower. Do Not leave a running machine unattended.
- Stop engine, wait for all moving parts to stop:
 - Before refueling.
 - Before dumping the grass catcher.
 - Before making height adjustments.
- Tragic accidents can occur if the operator is not alert to the presence of children. Children are often attracted to the machine and the mowing activity. Never assume that children will remain where you last saw them.
 - Keep children out of the mowing area and under the watchful care of another responsible adult, not the operator.
 - Be alert and turn the machine off if children enter the area.
 - Before and while backing or changing direction, look behind, down, and side-to-side for small children.
 - Never allow children to operate the machine.
 - Do Not carry children, even with the blades shut off. Children could fall off and be seriously injured or interfere with the safe operation of the machine. Children that have been given rides in the past could suddenly appear in the working area for another ride and be run over or backed over by the machine.

▲ WARNING

Hands, feet, hair, clothing, or accessories can become entangled in rotating parts. Contact with the rotating parts can cause traumatic amputation or severe lacerations.

- **Do Not operate the machine without guards, shields, and safety devices in place and working properly.**
- **Keep hands, feet, hair, jewelry, or clothing away from rotating parts.**
- Never raise the deck with blades running.
- Be aware of the mower discharge path and direct discharge away from others. Avoid discharging material against a wall or obstruction as the material may ricochet back toward the operator. Stop the blades, slow down, and use caution when crossing surfaces other than grass and when transporting the mower to and from the area to be mowed.
- Be alert, slow down and use caution when making turns. Look behind and to the side before changing directions. Do Not mow in reverse unless absolutely necessary.
- Do Not change the engine governor setting or overspeed the engine.
- Park the machine on level ground. Shut off the engine and wait for all moving parts to stop.
 - Before checking, cleaning or working on the mower.
 - After striking a foreign object or abnormal vibration occurs (inspect the mower for damage and make repairs before restarting and operating the mower).
 - Before clearing blockages.

Slope Safety

- Slopes are a major factor related to loss of control and rollover accidents, which can result in severe injury or death. The operator is responsible for safe slope operation. Operating the machine on any slope requires extra caution. Before using the machine on a slope, the operator must:
 - Review and understand the slope instructions in the manual and on the machine.
 - Use an angle indicator to determine the approximate slope angle of the area.
 - Never operate on slopes greater than 15 degrees.
 - Evaluate the site conditions of the day to determine if the slope is safe for machine operation. Use common sense and good judgment when performing this evaluation. Changes in the terrain, such as moisture, can quickly affect the operation of the machine on a slope.
- Identify hazards at the base of the slope. Do Not operate the machine near drop offs, ditches, embankments, water or other hazards. The machine could suddenly roll over if a wheel goes over the edge or the edge collapses. Keep a safe

distance (twice the width of the machine) between the machine and any hazard. Use a walk behind machine or a hand trimmer to mow the grass in these areas.

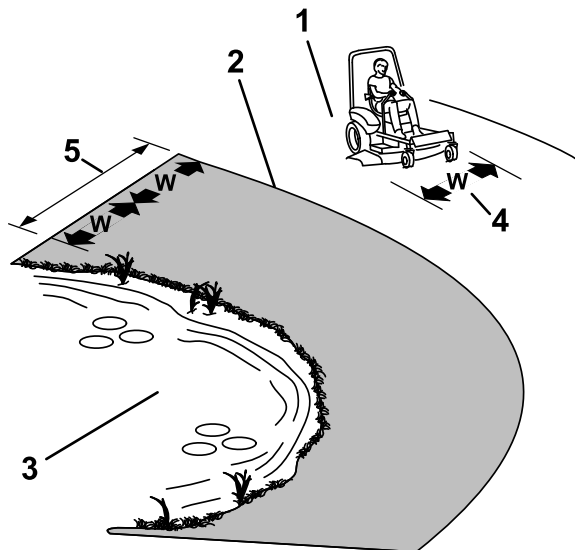

Figure 16

g221745

1. Safe Zone-Use the mower here on slopes less than 15 degrees
2. Danger Zone-Use a walk-behind mower and/or hand trimmer on slopes greater than 15 degrees
3. Water
4. W=width of the machine
5. Keep a safe distance (twice the width of the machine) between the machine and any hazard.

Rollover Protection System (ROPS) Safety

A Rollover Protection System (roll bar) is installed on the machine.

⚠ WARNING

There is no rollover protection when the roll bar is down. Wheels dropping over edges, ditches, steep banks, or water can cause rollovers, which may result in serious injury, death or drowning.

- Do Not remove the ROPS.
- Keep the roll bar in the raised and locked position and use seat belt.
- Lower the roll bar only when absolutely necessary.
- Do Not wear seat belt when the roll bar is down.
- Drive slowly and carefully.
- Raise the roll bar as soon as clearance permits.
- Be certain that the seat belt can be released quickly in the event of an emergency.
- Check carefully for overhead clearances (i.e. branches, doorways, and electrical wires) before driving under any objects and Do Not contact them.
- In the event of a rollover, take the unit to an Authorized Service Dealer to have the ROPS inspected.
- Replace a damaged ROPS. Do Not repair or revise.
- Any accessories, alterations, or attachments added to the ROPS must be approved by Toro.

- Avoid starting, stopping or turning the machine on slopes. Avoid making sudden changes in speed or direction; turn slowly and gradually.
- Do Not operate a machine under any conditions where traction, steering or stability is in question. Be aware that operating the machine on wet grass, across slopes or downhill may cause the machine to lose traction. Loss of traction to the drive wheels may result in sliding and a loss of braking and steering. The machine can slide even if the drive wheels are stopped.
- Remove or mark obstacles such as ditches, holes, ruts, bumps, rocks or other hidden hazards. Tall grass can hide obstacles. Uneven terrain could overturn the machine.
- Use extra care while operating with accessories or attachments, such as grass collection systems. These can change the stability of the machine and cause a loss of control. Follow directions for counter weights.
- If possible, keep the deck lowered to the ground while operating on slopes. Raising the deck while operating on slopes can cause the machine to become unstable.

Operating the Parking Brake

Always engage the parking brake when you stop the machine or leave it unattended.

Engaging the Parking Brake

Park the machine on a level surface.

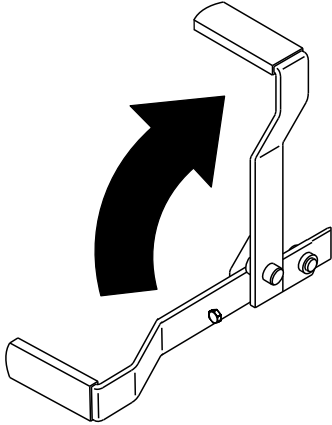

Figure 17

g187227

Disengaging the Parking Brake

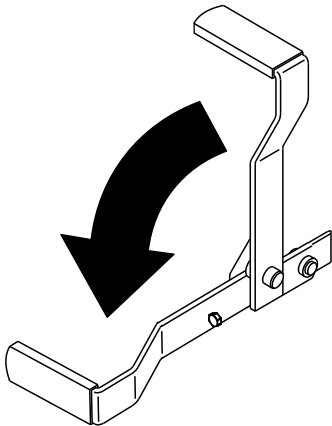

Figure 18

g187226

Operating the Mower Blade-Control Switch (PTO)

The blade-control switch (PTO) starts and stops the mower blades and any powered attachments.

Engaging the Blade-Control Switch (PTO)

Note: Engaging the blade-control switch (PTO) with the throttle position at half or less causes excessive wear to the drive belts.

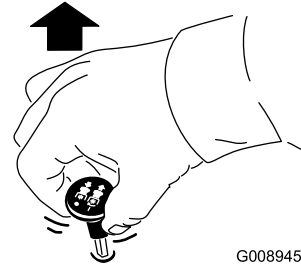

G008945

g008945

Figure 19

Disengaging the Blade-Control Switch (PTO)

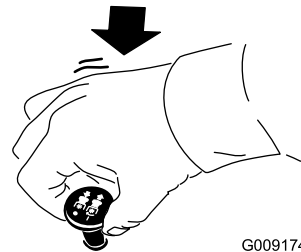

G009174

g009174

Figure 20

Operating the Throttle

You can move the throttle control between FAST and SLOW positions (Figure 21).

Always use the FAST position when engaging the PTO.

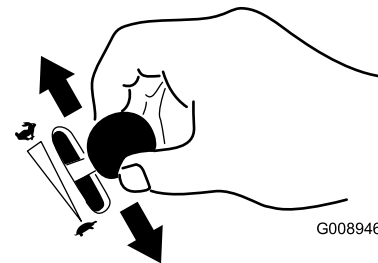

G008946

g008946

Figure 21

Starting the Engine in Normal Weather

Important: Use starting cycles of no more than 30 seconds per minute to avoid overheating the starter motor.

Note: Additional starting cycles may be required when starting the engine for the first time after the fuel system has been completely without fuel.

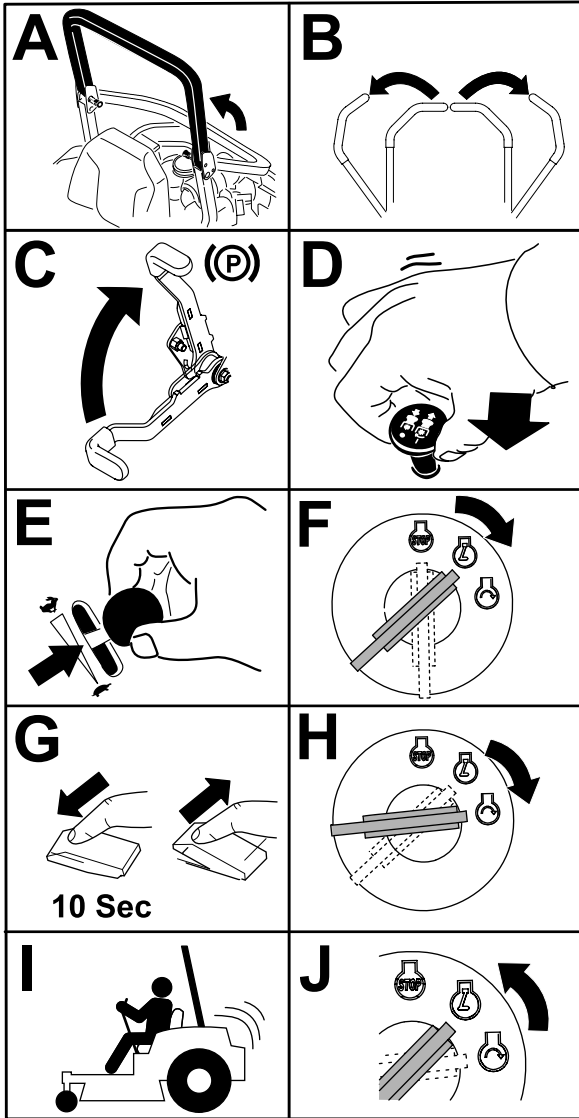

Figure 22

G032593 g032593

Starting the Engine in Cold Weather (Below 23°F or -5°C)

Use the correct engine oil for the starting temperature; refer to [Engine-Oil Specifications](#) (page 47).

Important: Use starting cycles of no more than 30 seconds per minute to avoid overheating the starter motor.

Note: Do not use fuel left over from the summer. Use only fresh winter-grade diesel fuel.

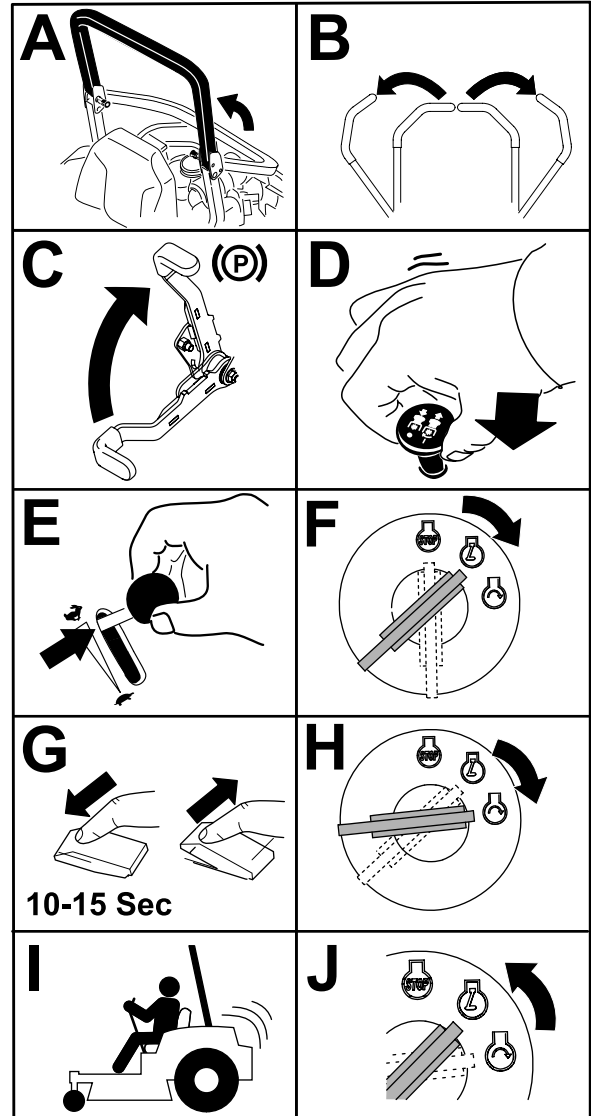

Figure 23

G032594 g032594

Shutting Off the Engine

⚠ CAUTION

Children or bystanders may be injured if they move or attempt to operate the machine while it is unattended.

Always remove the key and engage the parking brake when leaving the machine unattended.

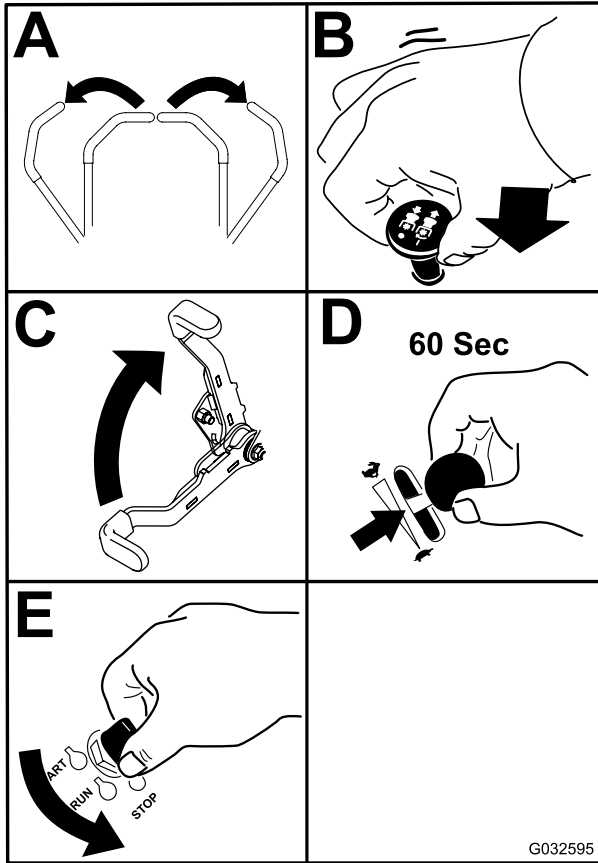

Figure 24

Using the Motion-Control Levers

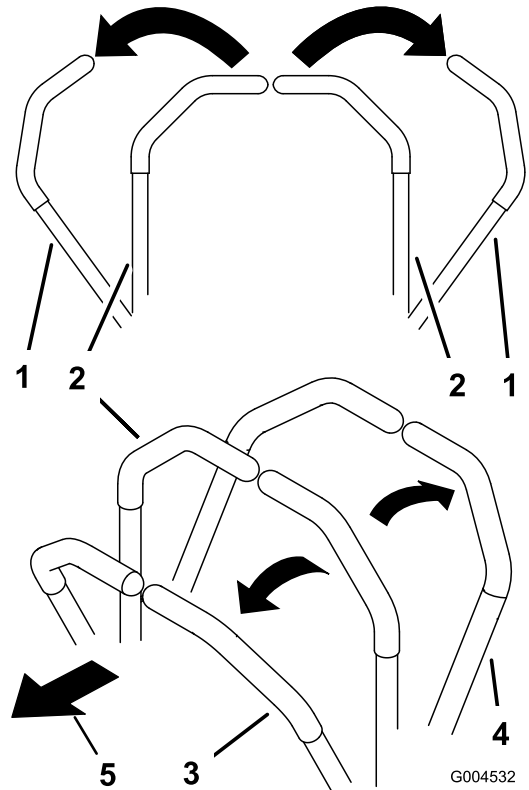

Figure 25

- 1. Motion-control lever—NEUTRAL-LOCK position
- 2. Center, unlocked position
- 3. Forward
- 4. Backward
- 5. Front of machine

Important: Make sure that the fuel-shutoff valve is closed before transporting or storing the machine, as fuel leakage may occur. Engage the parking brake before transporting. Make sure that you remove the key as the fuel pump may run and cause the battery to lose charge.

Driving the Machine

The drive wheels turn independently, powered by hydraulic motors on each axle. You can turn 1 side in reverse while you turn the other forward, causing the machine to spin rather than turn. This greatly improves the machine maneuverability but may require some time for you to adapt to how it moves.

The throttle control regulates the engine speed as measured in rpm (revolutions per minute). Place the throttle control in the FAST position for best performance. Always operate in the full throttle position when mowing.

⚠ WARNING

The machine can spin very rapidly. You may lose control of the machine and cause personal injury or damage to the machine.

- Use caution when making turns.
- Slow the machine down before making sharp turns.

Driving Forward

Note: The engine shuts off when you move the traction-control with the parking brake engaged.

To stop the machine, pull the motion-control levers to the NEUTRAL position.

1. Disengage the parking brake; refer to [Disengaging the Parking Brake \(page 25\)](#).
2. Move the levers to the center, unlocked position.
3. To go forward, slowly push the motion-control levers forward ([Figure 26](#)).

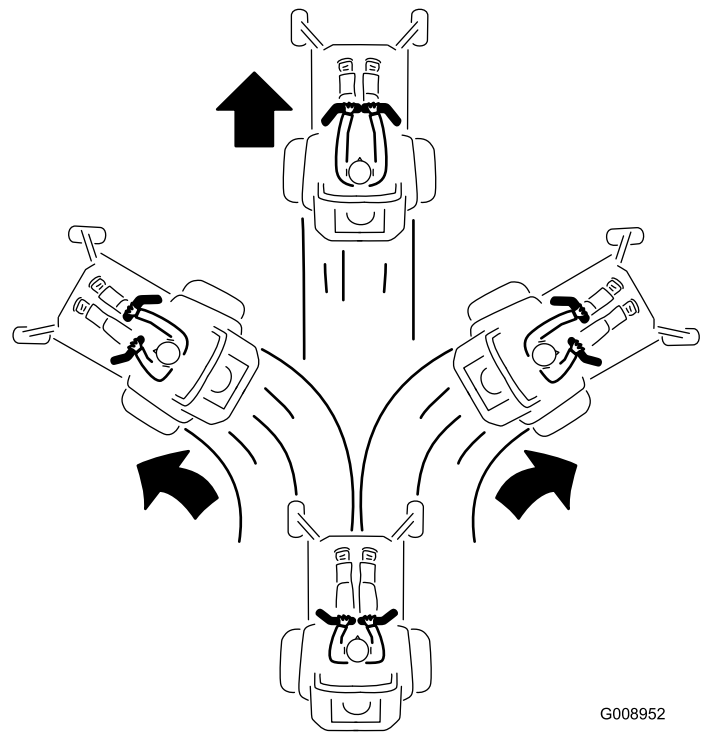

Figure 26

G008952
g008952

Driving Backward

1. Move the levers to the center, unlocked position.
2. To go backward, slowly pull the motion-control levers rearward ([Figure 27](#)).

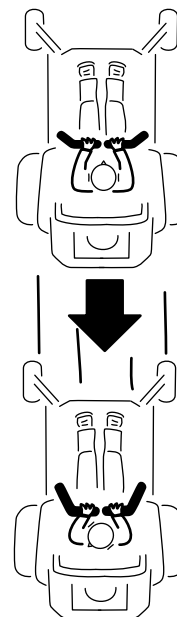

Figure 27

G008953

g008953

Using the Side Discharge Machines with Side Discharge Only

The mower has a hinged grass deflector that disperses clippings to the side and down toward the turf.

⚠ DANGER

Without a grass deflector, discharge cover, or a complete grass-catcher assembly mounted in place, you and others are exposed to blade contact and thrown debris. Contact with rotating mower blade(s) and thrown debris will cause injury or death.

- Never remove the grass deflector from the mower deck because the grass deflector routes material down toward the turf. If the grass deflector is ever damaged, replace it immediately.
- Never put your hands or feet under the mower deck.
- Never try to clear the discharge area or mower blades unless you move the blade-control switch (PTO) to the OFF position, rotate the key switch to the OFF position, and remove the key from the key switch.
- Make sure that the grass deflector is in the down position.

Adjusting the Height of Cut

Adjust the height of cut from 38 to 127 mm (1-1/2 to 5 inches) in 6 mm (1/4 inch) increments by moving the clevis pin into different hole locations.

1. Raise the height-of-cut lever to the TRANSPORT position (also the 127 mm (5 inch) cutting-height position) (Figure 28).

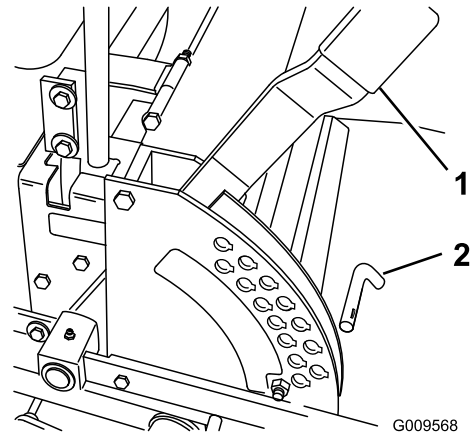

Figure 28

1. Height-of-cut lever

2. Pin

2. To adjust, remove the pin from the height-of-cut bracket (Figure 28).
3. Select a hole in the height-of-cut bracket corresponding to the height of cut desired, and insert the pin (Figure 28).
4. Move the lever to the selected height.

Adjusting the Anti-Scalp Rollers

Machines with Side Discharge

Whenever you change the height-of-cut, adjust the height of the anti-scalp rollers.

1. Park the machine on a level surface, disengage the blade-control switch, and engage the parking brake.
2. Shut off the engine, remove the key, and wait for all moving parts to stop before leaving the operating position.
3. Adjust the anti-scalp rollers as shown in [Figure 29](#), [Figure 30](#), and [Figure 31](#).

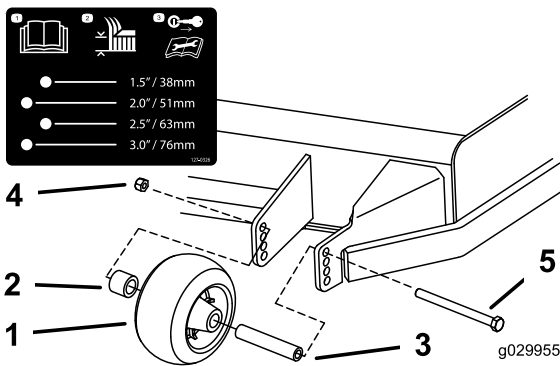

Figure 29

- | | |
|----------------------|---------------|
| 1. Anti-scalp roller | 4. Flange nut |
| 2. Spacer | 5. Bolt |
| 3. Bushing | |

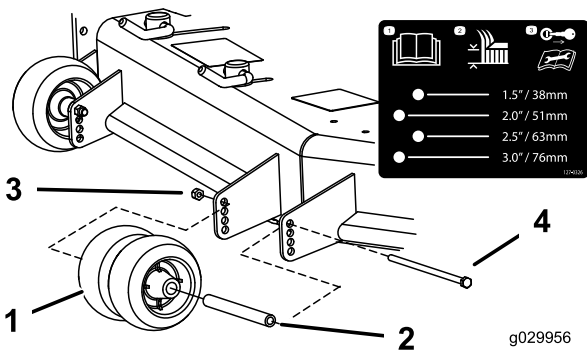

Figure 30

- | | |
|----------------------|---------------|
| 1. Anti-scalp roller | 3. Flange nut |
| 2. Bushing | 4. Bolt |

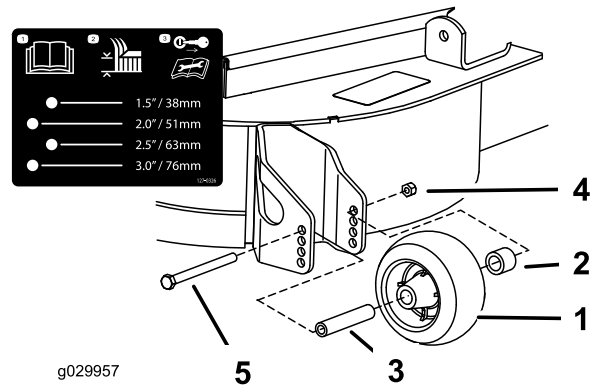

Figure 31

- | | |
|----------------------|---------------|
| 1. Anti-scalp roller | 4. Flange nut |
| 2. Spacer | 5. Bolt |
| 3. Bushing | |

Machines with Rear Discharge

Whenever you change the height of cut, it is recommended to adjust the height of the anti-scalp rollers.

1. Park the machine on a level surface, disengage the blade-control switch, and engage the parking brake.
2. Shut off the engine, remove the key, and wait for all moving parts to stop before leaving the operating position.
3. Adjust the anti-scalp rollers as shown in [Figure 32](#) and [Figure 33](#).

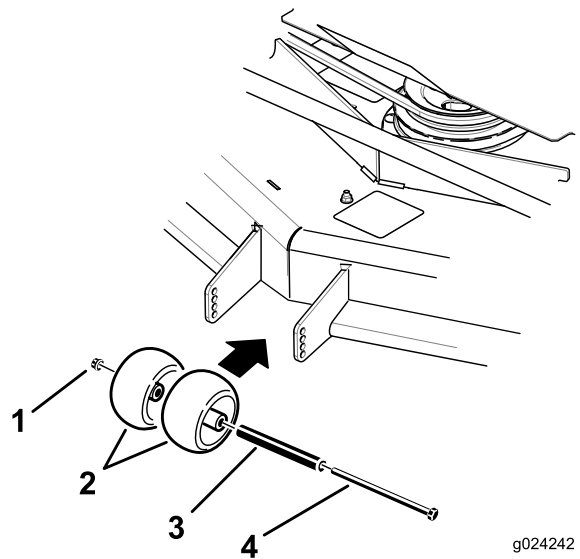

Figure 32

- | | |
|----------------------|------------|
| 1. Flange nut | 3. Bushing |
| 2. Anti-scalp roller | 4. Bolt |

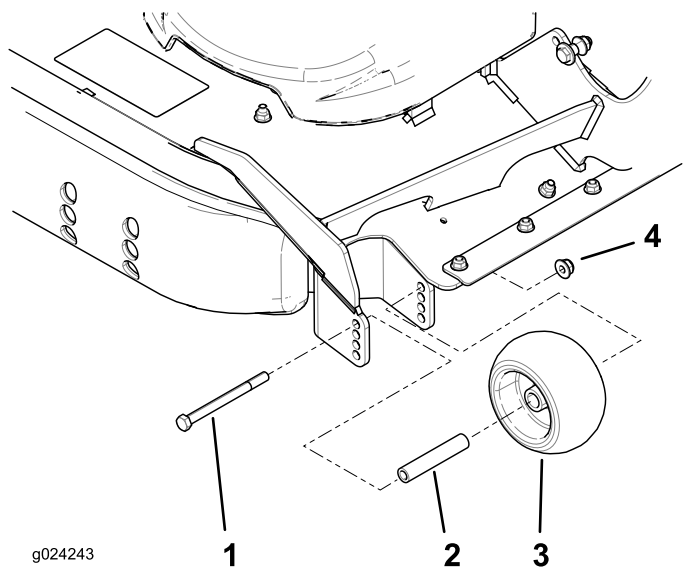

Figure 33

- | | |
|------------|----------------------|
| 1. Bolt | 3. Anti-scalp roller |
| 2. Bushing | 4. Flange nut |

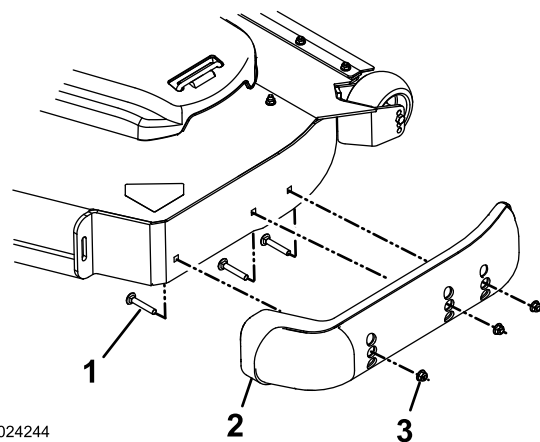

Figure 34

- | | |
|------------------|--------|
| 1. Carriage bolt | 3. Nut |
| 2. Skid | |

Adjusting the Skid(s) For Machines with Rear Discharge

Mount the skids in the lower position when operating in height of cuts higher than 64 mm (2-1/2 inches) and in the higher position when operating in height of cuts lower than 64 mm (2-1/2 inches).

Note: When the skids become worn, switch the skid to the opposite sides of the mower, flipping them over. This allows you to use the skids longer before replacing them.

1. Park the machine on a level surface, disengage the blade-control switch, and engage the parking brake.
2. Shut off the engine, remove the key, and wait for all moving parts to stop before leaving the operating position.
3. Remove the carriage bolts and nuts from each skid (Figure 34).

4. Move each skid to the desired position and secure them with the carriage bolts and nuts.

Note: Only use the top or center sets of holes to adjust the skids. The bottom holes are used when switching sides on the mower deck, at which time they become the top holes on the other side of the mower.

5. To prevent damaging the skid, torque the carriage bolts and nuts for each skid to 12.4 to 14.7 N·m (110 to 130 in-lb).

Adjusting the Flow Baffle Knob

For Machines with Side Discharge

This procedure applies only to machines with the flow baffle knob. Certain models have nuts and bolts instead of the flow baffle knob that you can adjust the same way.

You can adjust the mower discharge flow for different types of mowing conditions. Position the knob and baffle to give the best quality of cut.

1. Park the machine on a level surface, disengage the blade-control switch, and engage the parking brake.
2. Shut off the engine, remove the key, and wait for all moving parts to stop before leaving the operating position.
3. Loosen the knob.
4. Slide the knob to the desired position.
5. Tighten the knob.

Positioning the Flow Baffle For Machines with Side Discharge

The following figures are recommendations only. Adjustments vary by grass type, moisture content, and the height of the grass.

Note: If the engine power draws down and the mower ground speed is the same, open the baffle.

Position A

This is the fully-rear position. The suggested use for this position is as follows:

- Short, light grass mowing conditions
- Dry conditions
- Smaller grass clippings
- Propels grass clippings farther away from the mower

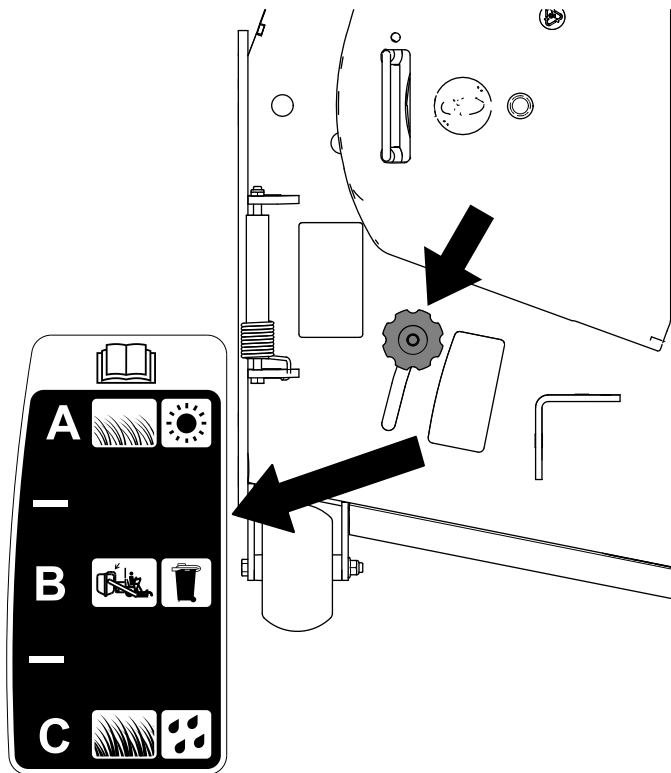

Figure 35

g295810

Position B

Use this position when bagging. Always align it with the blower opening.

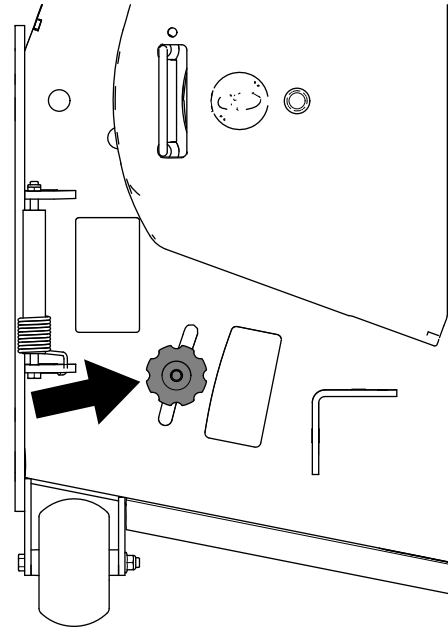

Figure 36

g295811

Position C

This is the fully-forward position. The suggested use for this position is as follows:

- Tall, dense grass mowing conditions
- Wet conditions
- Lowers the engine-power consumption
- Allows increased ground speed in heavy conditions

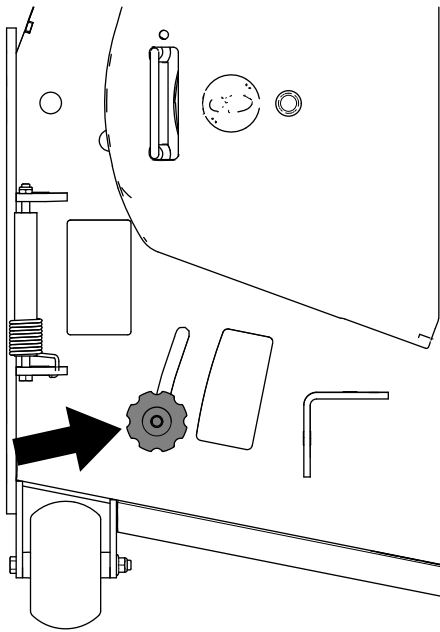

Figure 37

g295812

Operating with the Overheat Sensor

This machine has a sensor that turns off the mower deck when the engine overheats. When the engine overheats, the audible alarm and light alarm turns on along with the mower deck turning off.

If the mower deck turns off automatically because of overheating, you will be able to drive the machine to a safe area or to a truck or trailer.

If the machine overheats, ensure that the area around the engine and radiator is clear of any debris. Shut off the engine and allow it to cool before you engage the mower deck. If the engine continues to overheat, take your machine to an Authorized Service Dealer.

Operating Tips

Using the Fast Throttle Setting

For best mowing and maximum air circulation, operate the engine at the FAST position. Air is required to thoroughly cut grass clippings, so do not set the height-of-cut so low as to totally surround the mower deck in uncut grass. Always try to have 1 side of the mower deck free from uncut grass, which allows air to be drawn into the mower deck.

Cutting a Lawn for the First Time

Cut grass slightly longer than normal to ensure that the cutting height of the mower deck does not scalp any uneven ground. However, the cutting height used in the past is generally the best one to use. When cutting grass longer than 15 cm (6 inches) tall, you may want to cut the lawn twice to ensure an acceptable quality of cut.

Cutting a Third of the Grass Blade

It is best to cut only about a third of the grass blade. Cutting more than that is not recommended unless grass is sparse, or it is late fall when grass grows more slowly.

Alternating the Mowing Direction

Alternate the mowing direction to keep the grass standing straight. This also helps disperse clippings, which enhances decomposition and fertilization.

Mowing at Correct Intervals

Grass grows at different rates at different times of the year. To maintain the same cutting height, mow more often in early spring. As the grass growth rate slows in mid summer, mow less frequently. If you cannot mow for an extended period, first mow at a high cutting height, then mow again 2 days later at a lower height setting.

Using a Slower Cutting Speed

To improve cut quality, use a slower ground speed in certain conditions.

Avoiding Cutting Too Low

When mowing uneven turf, raise the cutting height to avoid scalping the turf.

Stopping the Machine

If you must stop the forward motion of the machine while mowing, a clump of grass clippings may

drop onto your lawn. To avoid this, move onto a previously cut area with the blades engaged or you can disengage the mower deck while moving forward.

Keeping the Underside of the Mower Deck Clean

Clean clippings and dirt from the underside of the mower deck after each use. If grass and dirt build up inside the mower deck, cutting quality will eventually become unsatisfactory.

Maintaining the Blade(s)

Maintain a sharp blade throughout the cutting season because a sharp blade cuts cleanly without tearing or shredding the grass blades. Tearing and shredding turns grass brown at the edges, which slows growth and increases the chance of disease. Check the mower blades after each use for sharpness, and for any wear or damage. File down any nicks and sharpen the blades as necessary. If a blade is damaged or worn, replace it immediately with a genuine Toro replacement blade.

After Operation

After Operation Safety

General Safety

- Park machine on level ground, disengage drives, set parking brake, stop engine, and remove key. Wait for all movement to stop and allow the machine to cool before adjusting, cleaning, repairing, or storing. Never allow untrained personnel to service machine.
- Clean the machine as stated in the Maintenance section. Keep engine and engine area free from accumulation of grass, leaves, excessive grease or oil, and other debris which can accumulate in these areas. These materials can become combustible and may result in a fire.
- Frequently check for worn or deteriorating components that could create a hazard. Tighten loose hardware.

Using the Fuel-Shutoff Valve

The fuel-shutoff valve is located under the seat. Move the seat forward to access it.

Close the fuel-shutoff valve for transport, maintenance, and storage.

Ensure that the fuel-shutoff valve is open when starting the engine.

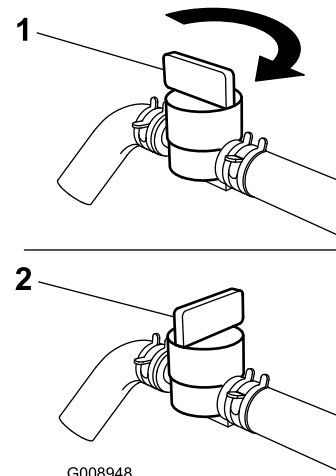

G008948

g008948

Figure 38

1. ON position

2. OFF position

Pushing the Machine by Hand

Important: Always push the machine by hand. Never tow the machine because hydraulic damage may occur.

Pushing the Machine

1. Park the machine on a level surface, disengage the blade-control switch, and engage the parking brake.
2. Shut off the engine, remove the key, and wait for all moving parts to stop before leaving the operating position.
3. Rotate the bypass valves counterclockwise 1 turn to push (Figure 39).

Note: This allows hydraulic fluid to bypass the pump enabling the wheels to turn.

Important: Do not rotate bypass valves more than 1 turn. This prevents valves from coming out of the body and causing fluid to run out.

4. Disengage the parking brake before pushing.

Changing to Machine Operation

Rotate the bypass valves clockwise 1 turn to operate machine (Figure 39).

Note: Do not over-tighten the bypass valves.

Important: The machine does not drive unless bypass valves are turned in.

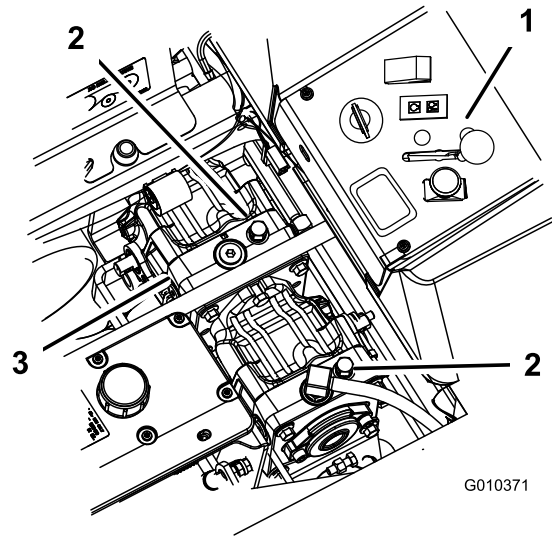

Figure 39

1. Side console controls
2. Bypass valve
3. Hydraulic pumps

Transporting the Machine

Use a heavy-duty trailer or truck to transport the machine. Use a full-width ramp. Ensure that the trailer or truck has all the necessary brakes, lighting, and marking as required by law. Please carefully read all the safety instructions. Knowing this information could help you or bystanders avoid injury. Refer to your local ordinances for trailer and tie-down requirements.

⚠ WARNING

Driving on the street or roadway without turn signals, lights, reflective markings, or a slow-moving-vehicle emblem is dangerous and can lead to accidents, causing personal injury.

Do not drive the machine on a public street or roadway.

Selecting a Trailer

⚠ WARNING

Loading a machine onto a trailer or truck increases the possibility of tip-over and could cause serious injury or death (Figure 40).

- Use only a full-width ramp; do not use individual ramps for each side of the machine.
- Do not exceed a 15-degree angle between the ramp and the ground or between the ramp and the trailer or truck.
- Ensure that the length of the ramp is at least 4 times as long as the height of the trailer or truck bed to the ground. This ensures that the ramp angle does not exceed 15 degrees on flat ground.

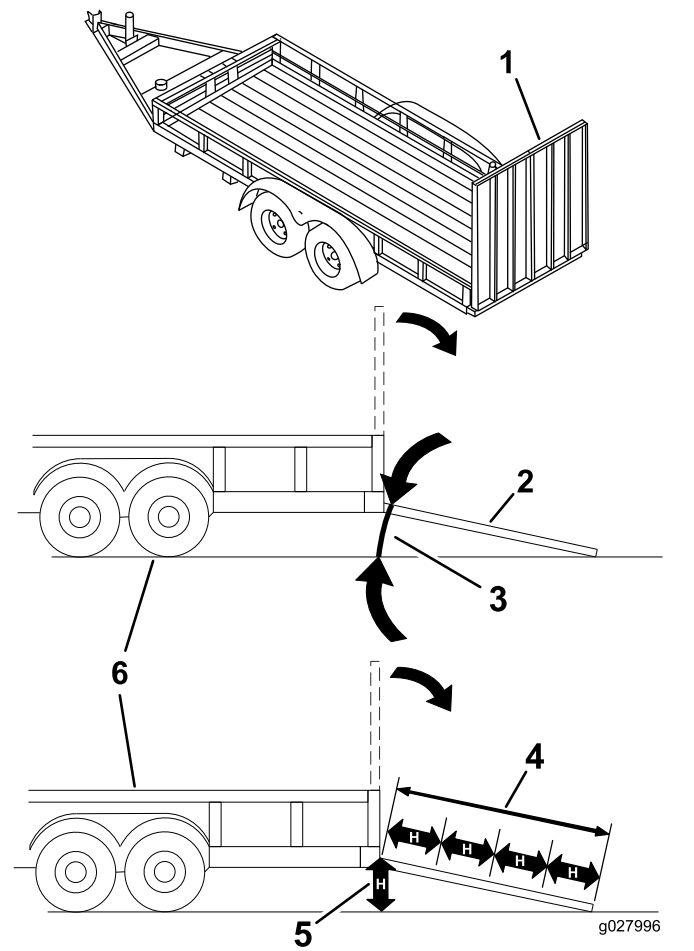

Figure 40

- | | |
|---|---|
| 1. Full-width ramp in stowed position | 4. Ramp is at least 4 times as long as the height of the trailer or truck bed to the ground |
| 2. Side view of full-width ramp in loading position | 5. H=height of the trailer or truck bed to the ground |
| 3. Not greater than 15 degrees | 6. Trailer |

Loading the Machine

⚠ WARNING

Loading a machine onto a trailer or truck increases the possibility of tip-over and could cause serious injury or death.

- Use extreme caution when operating a machine on a ramp.
- Back the machine up the ramp and drive it forward down the ramp.
- Avoid sudden acceleration or deceleration while driving the machine on a ramp as this could cause a loss of control or a tip-over situation.

1. If using a trailer, connect it to the towing vehicle and connect the safety chains.
2. If applicable, connect the trailer brakes and lights.
3. Lower the ramp, ensuring that the angle between the ramp and the ground does not exceed 15 degrees ([Figure 40](#)).
4. Back the machine up the ramp ([Figure 41](#)).

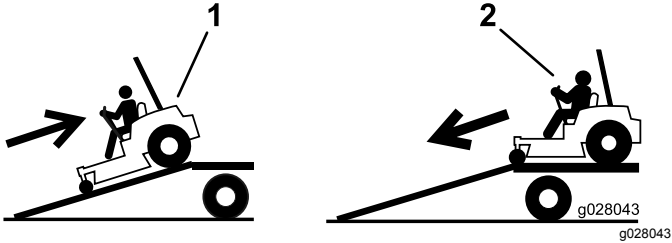

Figure 41

1. Back the machine up the ramp.
2. Drive the machine forward down the ramp.

5. Shut off the engine, remove the key, and engage the parking brake.
6. Tie down the machine near the front caster wheels and the rear bumper with straps, chains, cable, or ropes ([Figure 42](#)). Refer to local regulations for tie-down requirements.

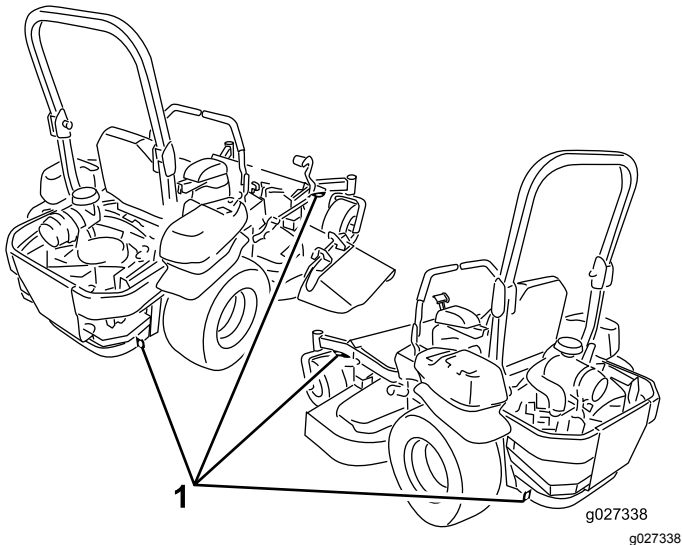

Figure 42

1. Tie-down loops

Unloading the Machine

1. Lower the ramp, ensuring that the angle between the ramp and the ground does not exceed 15 degrees ([Figure 40](#)).
2. Drive the machine forward down the ramp ([Figure 41](#)).

Maintenance

Maintenance Safety

⚠ WARNING

While maintenance or adjustments are being made, someone could start the engine. Accidental starting of the engine could seriously injure you or other bystanders.

Remove the key from the ignition switch and engage parking brake before you do any maintenance.

⚠ WARNING

The engine can become very hot. Touching a hot engine can cause severe burns.

Allow the engine to cool completely before service or making repairs around the engine area.

- Park machine on level ground, disengage drives, set parking brake, stop engine, and remove key. Wait for all movement to stop and allow the machine to cool before adjusting, cleaning or repairing. Never allow untrained personnel to service machine.
- Disconnect battery before making any repairs. Disconnect the negative terminal first and the positive last. Reconnect positive first and negative last.
- Keep the machine, guards, shields and all safety devices in place and in safe working condition. Frequently check for worn or deteriorating components and replace them with the manufacturer's recommended parts when necessary.

⚠ WARNING

Removal or modification of original equipment, parts and/or accessories may alter the warranty, controllability, and safety of the machine. Unauthorized modifications to the original equipment or failure to use original Toro parts could lead to serious injury or death. Unauthorized changes to the machine, engine, fuel or venting system, may violate applicable safety standards such as: ANSI, OSHA and NFPA and/or government regulations such as EPA and CARB.

⚠ WARNING

Hydraulic fluid escaping under pressure can penetrate skin and cause injury. Fluid accidentally injected into the skin must be surgically removed within a few hours by a doctor familiar with this form of injury or gangrene may result.

- If equipped, make sure all hydraulic fluid hoses and lines are in good condition and all hydraulic connections and fittings are tight before applying pressure to hydraulic system.
- Keep body and hands away from pinhole leaks or nozzles that eject high pressure hydraulic fluid.
- Use cardboard or paper, not your hands, to find hydraulic leaks.
- Safely relieve all pressure in the hydraulic system by placing the motion control levers in neutral and shutting off the engine before performing any work on the hydraulic system.

⚠ WARNING

Fuel system components are under high pressure. The use of improper components can result in system failure, fuel leakage and possible explosion.

Use only approved fuel lines and fuel filters for high pressure systems.

- Use care when checking blades. Wrap the blade(s) or wear gloves, and use caution when servicing them. Only replace damaged blades. Never straighten or weld them.
- Use jack stands to support the machine and/or components when required.

⚠ CAUTION

Raising the machine for service or maintenance relying solely on mechanical or hydraulic jacks could be dangerous. The mechanical or hydraulic jacks may not be enough support or may malfunction allowing the machine to fall, which could cause injury.

Do not rely solely on mechanical or hydraulic jacks for support. Use adequate jack stands or equivalent support.

- Carefully release pressure from components with stored energy.
- Keep hands and feet away from moving parts. If possible, Do Not make adjustments with the engine running. If the maintenance or adjustment procedure require the engine to be running and components moving, use extreme caution.

⚠ WARNING

Contact with moving parts or hot surfaces may cause personal injury.

Keep your fingers, hands, and clothing clear of rotating components and hot surfaces.

- Check all bolts frequently to maintain proper tightness.

Recommended Maintenance Schedule(s)

Maintenance Service Interval	Maintenance Procedure
After the first 8 hours	<ul style="list-style-type: none"> • Check the engine-coolant level. • Check the hydraulic fluid.
After the first 25 hours	<ul style="list-style-type: none"> • Change the hydraulic filter.
After the first 50 hours	<ul style="list-style-type: none"> • Replace the engine oil. • Change the engine-oil filter. • Change the engine oil.
After the first 100 hours	<ul style="list-style-type: none"> • Check the wheel lug-nut torque. • Check the wheel hub castle nut. • Change the gearbox oil.
Before each use or daily	<ul style="list-style-type: none"> • Check the safety-interlock system. • Check the engine-oil level. • Check the seat belt. • Check the engine-coolant level. • Clean the engine-oil cooler. • Inspect the blades. • Clean the mower deck.
Every 25 hours	<ul style="list-style-type: none"> • Grease the mower deck and spindles. • Grease the mower belt idler arm. • Grease the pump belt idler arm. • Grease the PTO-drive belt idler arm. • Grease the brake lever. • Check the hydraulic fluid.
Every 40 hours	<ul style="list-style-type: none"> • Drain the water separator.
Every 50 hours	<ul style="list-style-type: none"> • Check the tire pressure. • Check the PTO-drive belt. • Check the pump-drive belt. • Check the alternator belt.
Every 100 hours	<ul style="list-style-type: none"> • Lubricate the deck-lift pivots. • Replace the engine oil. • Change the engine oil. • Check the gearbox-oil level. • Check the engine cooling system hoses. • Inspect the belts for cracks and wear. • Check the alternator-belt tension.
Every 150 hours	<ul style="list-style-type: none"> • Add light oil or spray lubrication to the machine; refer to lubrication.
Every 200 hours	<ul style="list-style-type: none"> • Change the engine-oil filter. • Grease the brake pivot.

Maintenance Service Interval	Maintenance Procedure
Every 250 hours	<ul style="list-style-type: none"> • Check and/or replace the air filter (more often in dirty or dusty conditions). • Change the hydraulic filter and hydraulic fluid when using Mobil® 1 fluid.
Every 400 hours	<ul style="list-style-type: none"> • Grease the caster pivots (more often in dirty or dusty conditions). • Replace the fuel filter (more often in dirty or dusty conditions).
Every 500 hours	<ul style="list-style-type: none"> • Check the wheel lug-nut torque. • Check the wheel hub castle nut. • Adjust the caster-pivot bearing. • Adjust the electric clutch. • Change the hydraulic filter and hydraulic fluid when using Toro® HYPR-OIL™ 500 hydraulic fluid.
Monthly	<ul style="list-style-type: none"> • Check the battery charge.
Yearly	<ul style="list-style-type: none"> • Repack the caster-wheel bearings (more often in dirty or dusty conditions). • Greasing the caster-wheel hubs. • Change the gearbox oil. • Change the engine coolant.

Important: Refer to your engine owner's manual for additional maintenance procedures.

⚠ CAUTION

If you leave the key in the switch, someone could accidentally start the engine and seriously injure you or other bystanders.

Shut off the engine and remove the key from the switch before you perform any maintenance.

Pre-Maintenance Procedures

Using the Z Stand™

The Z Stand raises the front end of the machine to allow you to clean the mower and remove the blades.

⚠ WARNING

The machine could fall onto someone and cause serious injury or death.

- Use extreme caution when operating the machine on the Z Stand.
- Use the Z Stand only for cleaning the mower and removing the blades.
- Do not keep the machine on the Z Stand for extended periods of time.
- Always shut off the engine, set the parking brake, and remove the key before performing any maintenance to the mower.

Driving up onto the Z Stand

Important: Use the Z Stand on a level surface.

1. Raise the mower deck to the transport position.
2. Remove the bracket pin (Figure 43).

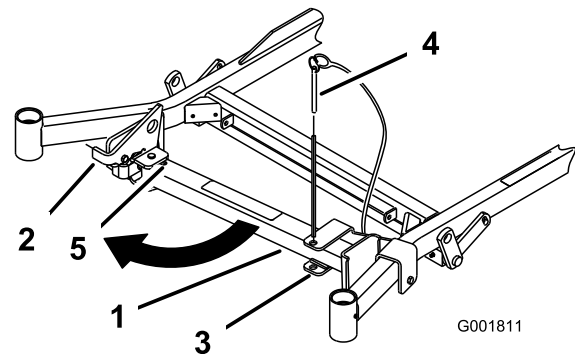

Figure 43

1. Z Stand
2. Bracket pin
3. Bracket
4. Bottom of slot
5. Latch

3. Raise the latch.

- Swing the stand foot out front and slide it toward machine, into the bottom of slot (Figure 43 and Figure 44).

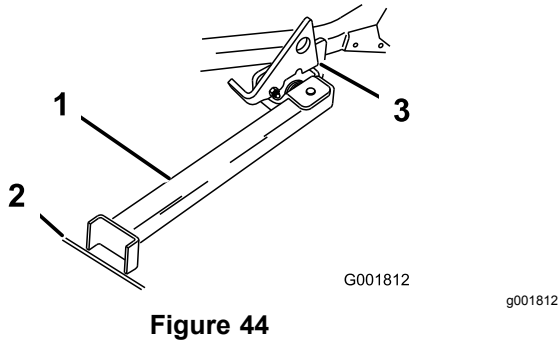

Figure 44

- Z Stand (positioned in slot)
- Crack in side walk or turf
- Latch resting on pivot tab

- Set the foot of the stand on the ground and rest the latch on the pivot tab (Figure 44).
- Start the engine and put it at half throttle.

Note: For best results, place the foot of the stand into the seams in sidewalks or into the turf (Figure 44).

- Drive the machine onto the stand. Stop when the latch drops over the tab into the locked position (Figure 44).
- Engage the parking brake, shut off the engine, and remove the key.
- Chock or block the drive wheels.

⚠ WARNING

The parking brake may not hold the machine parked on the Z Stand and could cause personal injury or property damage.

Do not park on the Z Stand unless the wheels are chocked or blocked.

- Perform the maintenance.

Driving off the Z Stand

- Remove the chocks or blocks.
- Raise the latch to the unlocked position (Figure 45).

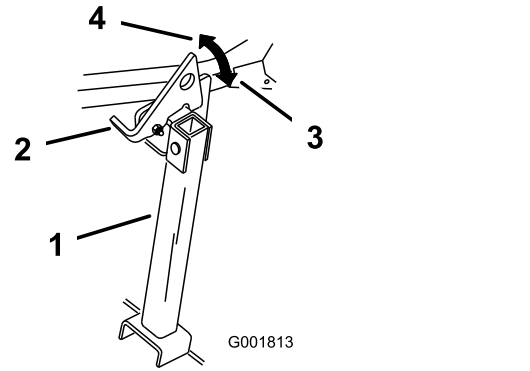

Figure 45

- Z Stand
- Latch
- Locked position
- Unlocked position

- Start the engine and place it at half throttle. Disengage the parking brake.
- Slowly drive backward off the stand.
- Return the stand to its rest position (Figure 43).

Releasing the Mower-Deck Curtain

Loosen the bottom bolt of the curtain to release the mower-deck curtain and get access to the top of the mower deck (Figure 46). After performing maintenance, install the curtain and tighten the bolt.

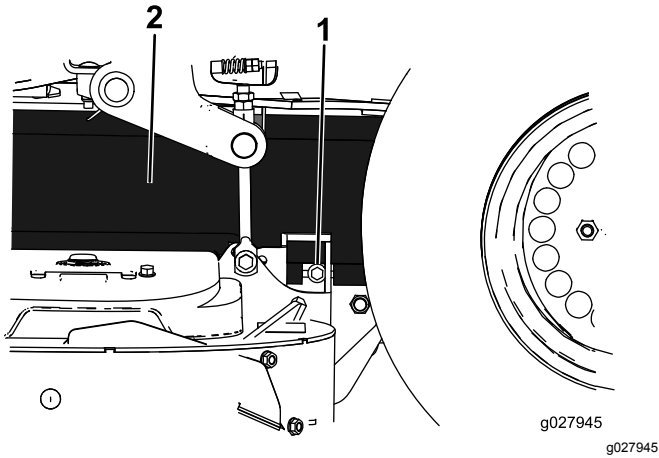

Figure 46

- 1. Bolt
- 2. Curtain

Removing the Sheet-Metal Guard

Loosen the 2 front bolts and remove the sheet-metal guard to access the mower belts and spindles (Figure 47). After performing maintenance, install the sheet-metal guard and tighten the bolts.

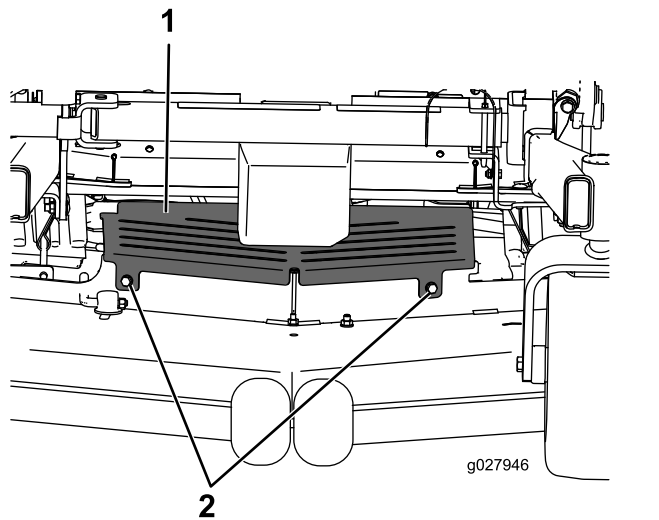

Figure 47

- 1. Sheet-metal guard
- 2. Bolt

Lubrication

Greasing the Machine

Grease the machine more often in dirty or dusty conditions. Refer to Figure 48 or Figure 49 for the location of grease fittings.

Grease Type: No. 2 lithium or molybdenum grease

1. Park the machine on a level surface, disengage the blade-control switch, and engage the parking brake.
2. Shut off the engine, remove the key, and wait for all moving parts to stop before leaving the operating position.
3. Clean the grease fittings with a rag.

Note: Scrape any paint off the front of the fitting(s).
4. Connect a grease gun to the fitting.
5. Pump grease into the fittings until grease begins to ooze out of the bearings.
6. Wipe up any excess grease.

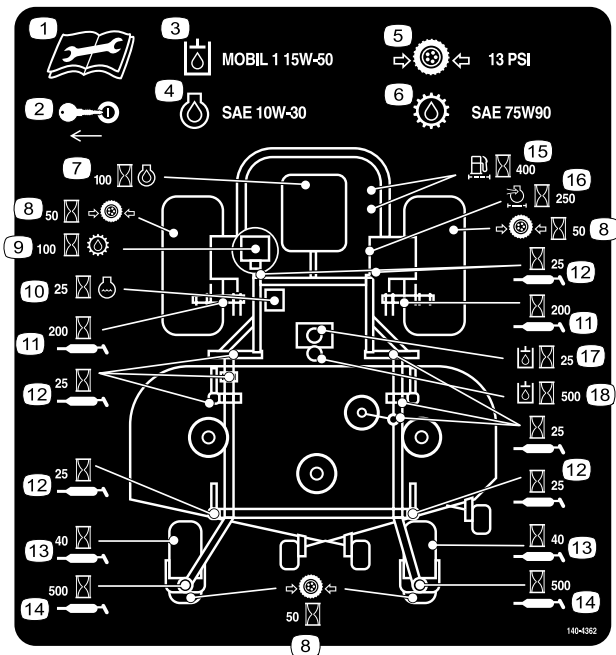
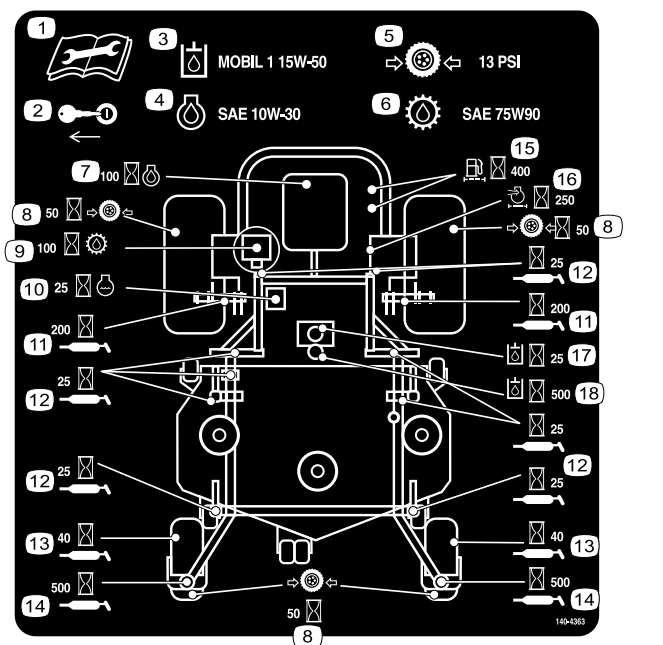

Figure 48
Side Discharge Machines



decal140-4363

Figure 49
Rear Discharge Machines

Rear-Discharge Machines

Service Interval: Every 150 hours

Use light oil or spray lubricant to lubricate the machine in the following areas:

- Seat-switch actuator
- Brake-handle pivot
- Brake-rod bushings
- Motion-control bronze bushings

Greasing the Mower Deck and Belt Idlers

Service Interval: Every 25 hours—Grease the mower deck and spindles.

Grease Type: No. 2 lithium or molybdenum grease

Important: Make sure that the mower-deck spindles are full of grease weekly.

1. Park the machine on a level surface, disengage the blade-control switch, and engage the parking brake.
2. Shut off the engine, remove the key, and wait for all moving parts to stop before leaving the operating position.
3. Loosen the bottom bolt holding the mower-deck curtain to the mower deck; refer to [Releasing the Mower-Deck Curtain \(page 42\)](#).
4. Remove the sheet-metal guard; refer to [Removing the Sheet-Metal Guard \(page 42\)](#).
5. Remove the belt covers.
6. Grease the idler arm on the mower deck ([Figure 51](#)).
7. Grease the fittings on the push arms ([Figure 51](#) or [Figure 52](#)).

Adding Light Oil or Spray Lubrication

Service Interval: Every 100 hours

Side-Discharge Machines

Use light oil or spray lubricant to lubricate the deck-lift pivots.

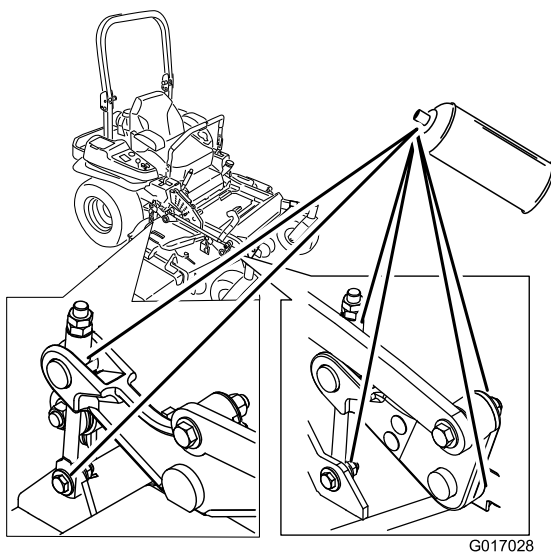

g017028

Figure 50

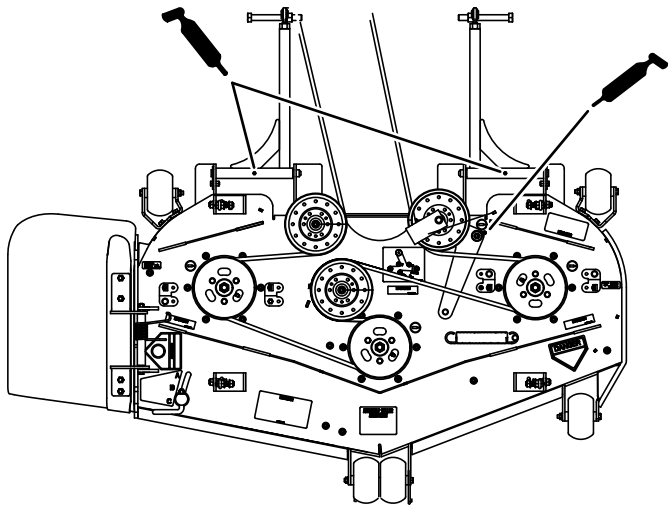

g187362

Figure 51
Side Discharge Machines

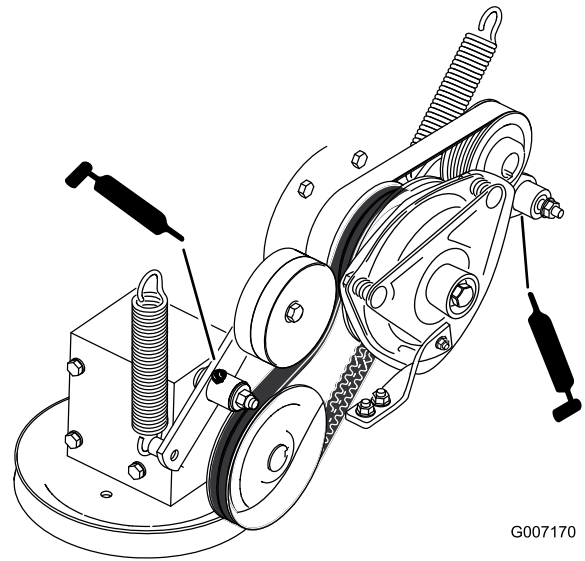

G007170

Figure 53

g007170

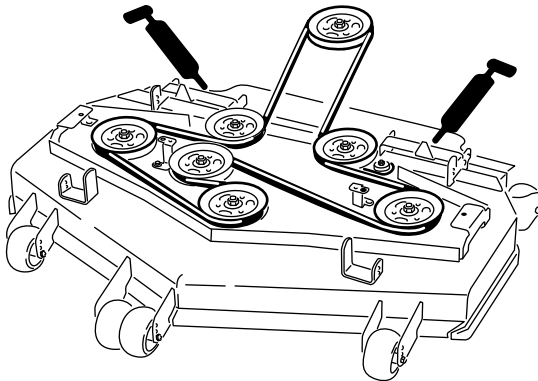

g194085

Figure 52
Rear Discharge Machines

8. Grease the PTO-drive belt idler arm ([Figure 53](#)).
9. Grease the pump belt idler arm ([Figure 53](#)).

10. Install the sheet-metal guard.
11. Tighten the bottom bolt holding the mower-deck curtain to the mower deck.

Greasing the Caster Pivots

Service Interval: Every 400 hours/Yearly (whichever comes first) (more often in dirty or dusty conditions).

Yearly—Repack the caster-wheel bearings (more often in dirty or dusty conditions).

1. Park the machine on a level surface, disengage the blade-control switch, and engage the parking brake.
2. Shut off the engine, remove the key, and wait for all moving parts to stop before leaving the operating position.
3. Remove the dust cap and adjust the caster pivots and keep the dust cap off until greasing is done; refer to [Adjusting the Caster-Pivot Bearing \(page 56\)](#).
4. Remove the hex plug.
5. Thread a grease fitting into the hole.
6. Pump grease into the fitting until it oozes out around the top bearing.
7. Remove the grease fitting from the hole. Install the hex plug and cap.

Greasing the Caster-Wheel Hubs

Service Interval: Yearly

1. Park the machine on a level surface, disengage the blade-control switch, and engage the parking brake.
2. Shut off the engine, remove the key, and wait for all moving parts to stop before leaving the operating position.
3. Raise the mower for access.
4. Remove the caster wheel from the caster forks.
5. Remove the seal guards from the wheel hub.

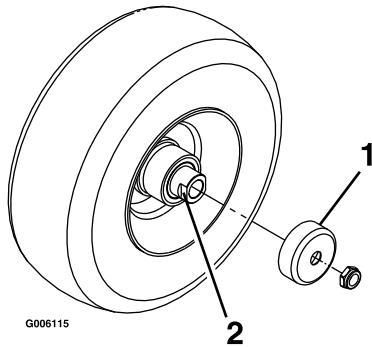

Figure 54

G006115

1. Seal guard
2. Spacer nut with wrench flats

6. Remove a spacer nut from the axle assembly in the caster wheel.

Note: Thread-locking compound has been applied to lock the spacer nuts to the axle.

7. Remove the axle (with the other spacer nut still assembled to it) from the wheel assembly.
8. Pry out seals and inspect bearings for wear or damage and replace if necessary.
9. Pack the bearings with a general-purpose grease.
10. Insert 1 bearing and 1 new seal into the wheel.
11. If the axle assembly is missing both spacer nuts, apply a thread-locking compound to 1 spacer nut and thread it onto the axle with the wrench flats facing outward.

Note: Do not thread the spacer nut all of the way onto the end of the axle. Leave approximately 3 mm (1/8 inch) from the outer surface of the spacer nut to the end of the axle inside the nut.

12. Insert the assembled nut and axle into the wheel on the side with the new seal and bearing.

13. With the open end of the wheel facing up, fill the area inside the wheel around the axle full of general-purpose grease.
14. Insert the second bearing and new seal into the wheel.
15. Apply a thread-locking compound to the second spacer nut, and thread it onto the axle with the wrench flats facing outward.
16. Torque the nut to 8 to 9 N·m (75 to 80 in-lb), loosen the nut, then torque it to 2 to 3 N·m (20 to 25 in-lb).
17. Install the seal guards over the wheel hub, and insert the wheel into the caster fork.
18. Install the caster bolt and tighten the nut fully.

Note: Make sure that the axle does not extend beyond either nut.

Important: To prevent seal and bearing damage, check the bearing adjustment often. Spin the caster tire. The tire should not spin freely (more than 1 or 2 revolutions) or have any side play. If the wheel spins freely, adjust the torque on the spacer nut until there is a slight amount of drag. Apply another layer of thread-locking compound.

Engine Maintenance

Engine Safety

- Shut off the engine before checking the oil or adding oil to the crankcase.
- Keep your hands, feet, face, clothing, and other body parts away from the muffler and other hot surfaces.

Servicing the Air Cleaner

Service Interval: Every 250 hours (more often in dirty or dusty conditions).

Note: Check the filters more frequently if operating conditions are extremely dusty or sandy.

Removing the Air Filter

1. Park the machine on a level surface, disengage the blade-control switch (PTO), and engage the parking brake.
2. Shut off the engine, remove the key, and wait for all moving parts to stop before leaving the operating position.
3. Release the latches on the air cleaner and pull the air-cleaner cover off the air-cleaner body (Figure 55).
4. Clean the inside of the air-cleaner cover with compressed air.
5. Gently slide the filter out of the air-cleaner body (Figure 55).

Note: Avoid knocking the filter into the side of the body.

6. Inspect the filter for damage by looking into the filter while shining a bright light on the outside of the filter.

Note: Holes in the filter appear as bright spots. If the filter is damaged, discard it.

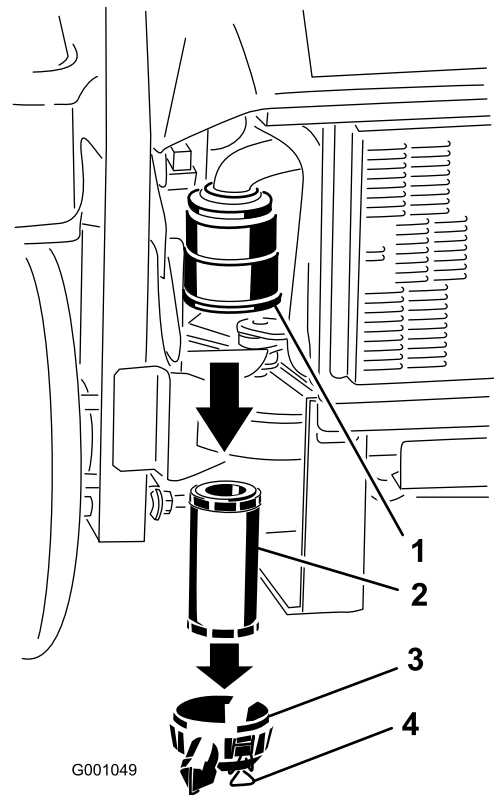

Figure 55

- | | |
|--------------------|----------------------|
| 1. Air-filter body | 3. Air-cleaner cover |
| 2. Air filter | 4. Latches |

Installing the Air Filter

1. If installing a new filter, check the filter for shipping damage. Do not use a damaged filter.
2. Carefully slide the filter into the filter body (Figure 56).

Note: Ensure that it is fully seated by pushing on the outer rim of the filter while installing it.

Important: Do not press on the soft inside area of the filter.

3. Install the air-cleaner cover and secure the latches (Figure 56).

Servicing the Engine Oil

Service Interval: Before each use or daily—Check the engine-oil level.

After the first 50 hours—Replace the engine oil.

Every 100 hours—Replace the engine oil.

After the first 50 hours—Change the engine-oil filter.

Every 200 hours—Change the engine-oil filter.

Engine-Oil Specifications

Oil Type: High-quality detergent oil classified API Service CJ-4 or higher for diesel engines. Do not use special additives with recommended oils.

Crankcase Capacity: 3.7 L (3.9 US qt)

Viscosity: See the table below.

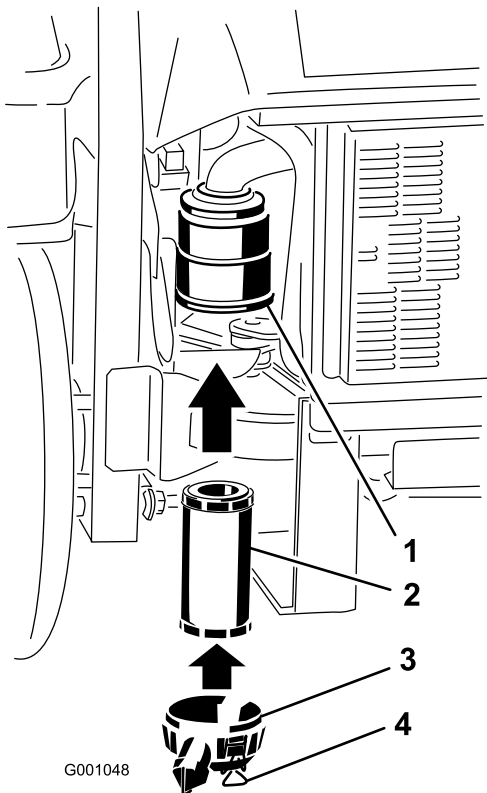

Figure 56

- 1. Air-filter body
- 2. Air filter
- 3. Air-cleaner cover
- 4. Latches

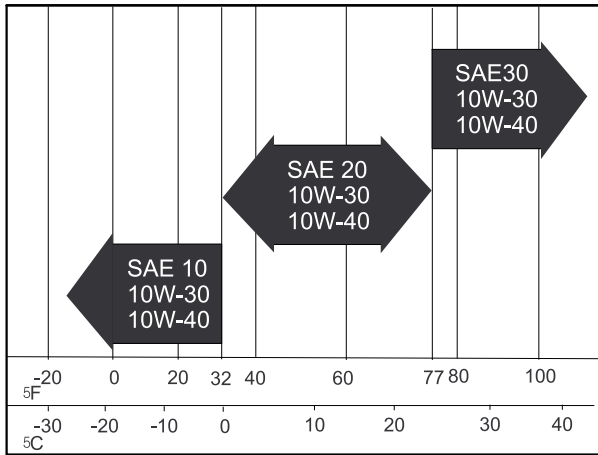

Figure 57

Checking the Engine-Oil Level

Note: Check the oil when the engine is cold.

1. Park the machine on a level surface, disengage the blade-control switch (PTO), and engage the parking brake.
2. Shut off the engine, remove the key, and wait for all moving parts to stop before leaving the operating position.
3. Check the engine-oil level (Figure 58).

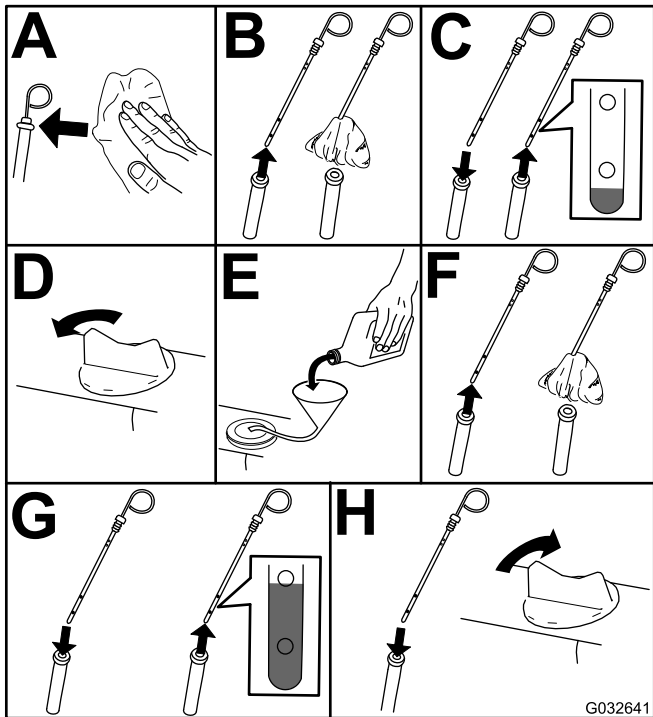
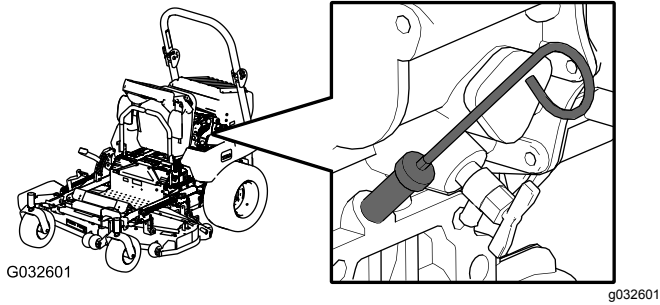

Figure 58

4. Start the engine, run it at idle for 5 minutes, shut off the engine, wait for 3 minutes, and then check the engine-oil level. If needed, add oil up to the FULL mark on the dipstick.

Important: Be sure to keep the engine-oil level between the upper and lower limits on the oil gauge. Engine failure may occur as a result.

Important: Add the oil very slowly and do not block the opening of the filler hole

(Figure 40). If you add oil too fast or block the hole, the oil could back up and foul the air intakes, causing engine damage.

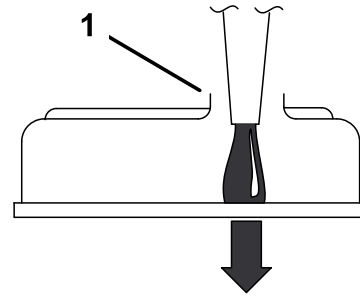

Figure 59

1. Note the clearance left in the filler opening.

Draining the Engine Oil

1. Start the engine and let it run for 5 minutes.
Note: This warms the oil so it drains better.
2. Park the machine on a level surface, disengage the blade-control switch (PTO), and engage the parking brake.
3. Shut off the engine, remove the key, and wait for all moving parts to stop before leaving the operating position.

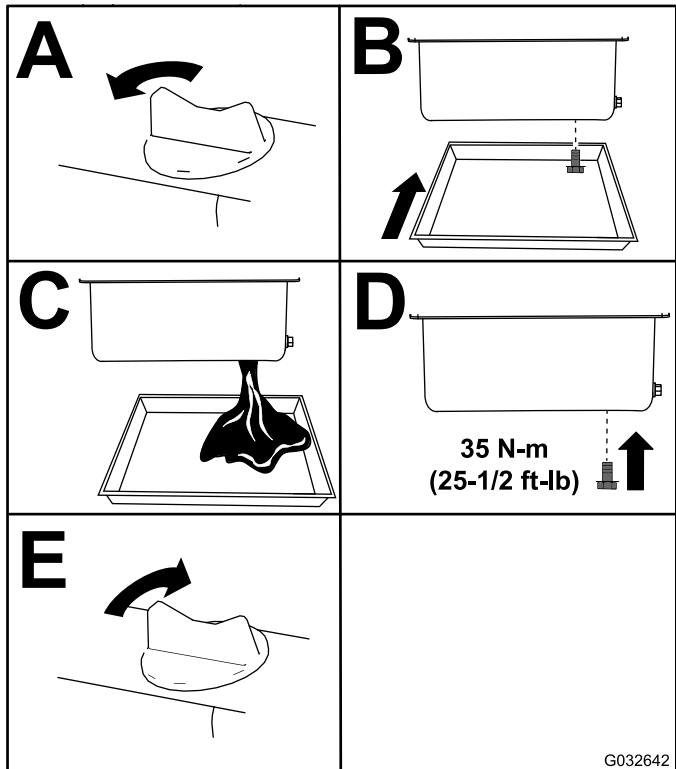
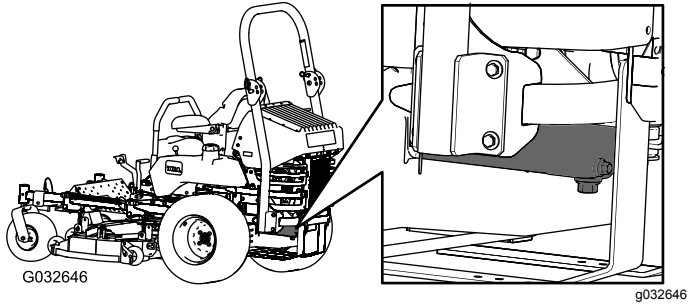

Figure 60

Changing the Engine-Oil Filter

1. Drain the oil from the engine; refer to [Draining the Engine Oil \(page 49\)](#).
2. Change the engine-oil filter ([Figure 61](#)).

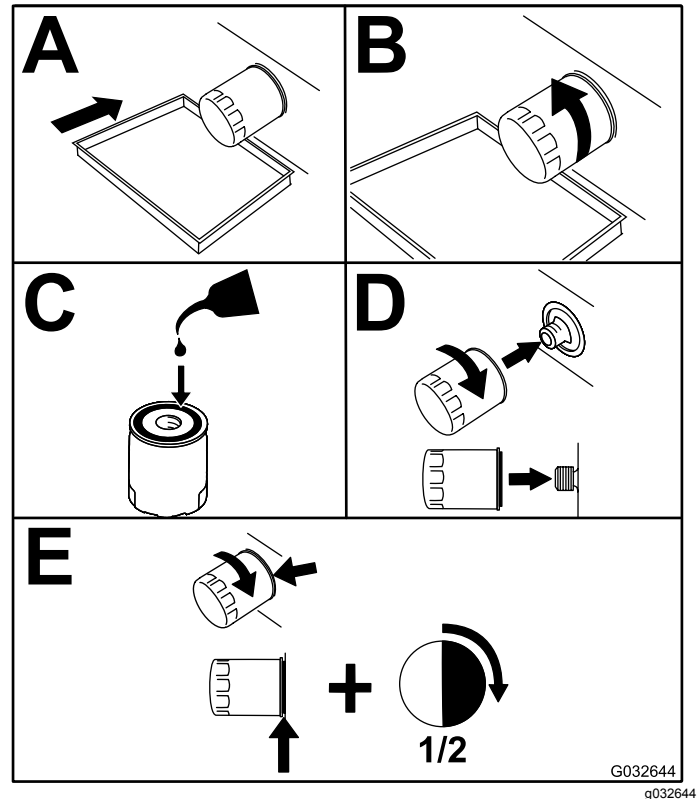
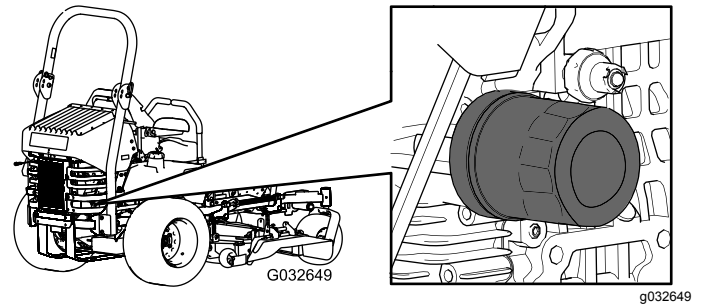

Figure 61

3. Add oil; refer to [Adding Engine Oil \(page 50\)](#).

Note: Dispose of the used oil at a recycling center.

Changing the Engine Oil

Service Interval: After the first 50 hours

Every 100 hours

1. Start the engine and let it run for 5 minutes.

Note: This warms the oil so it drains better.

- 2.
3. Park the machine on a level surface, disengage the blade-control switch (PTO), and engage the parking brake.
4. Shut off the engine, remove the key, and wait for all moving parts to stop before leaving the operating position.

5. Place a pan below the oil drain. Remove the drain plug and let the oil drain completely (Figure 62).

6. Remove the oil filler cap from the top of the engine (Figure 64).

Note: This helps the oil to drain.

7. Install the drain plug and tighten it to 35 N·m (25-1/2 ft-lb).

Note: Dispose of the used oil at a recycling center.

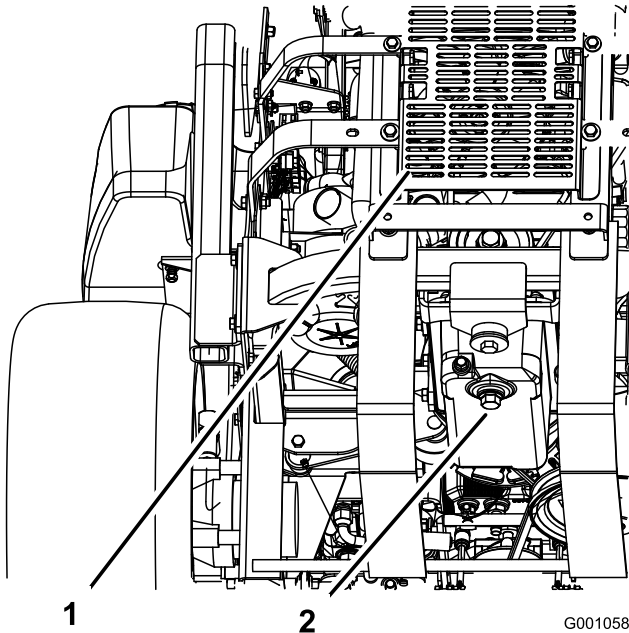

Figure 62

1. Back of the machine
2. Drain plug

Adding Engine Oil

1. Tilt the seat forward and remove the front engine panel (Figure 63).

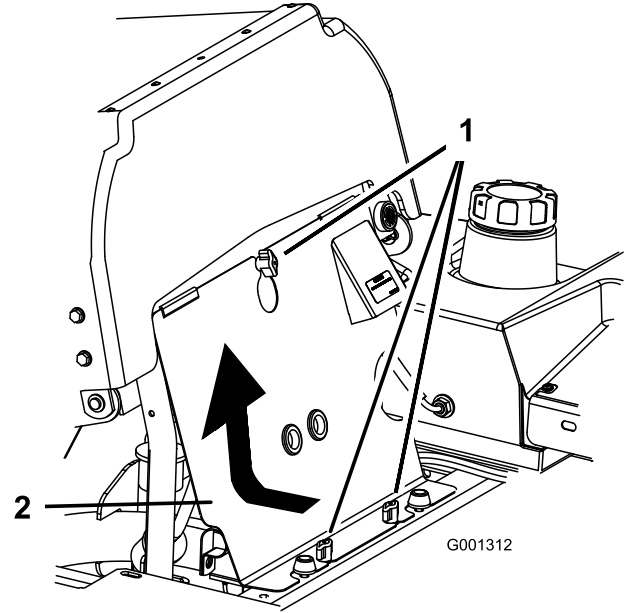

Figure 63

1. Knob
2. Front engine panel

2. Remove the oil-fill cap and dipstick (Figure 64).

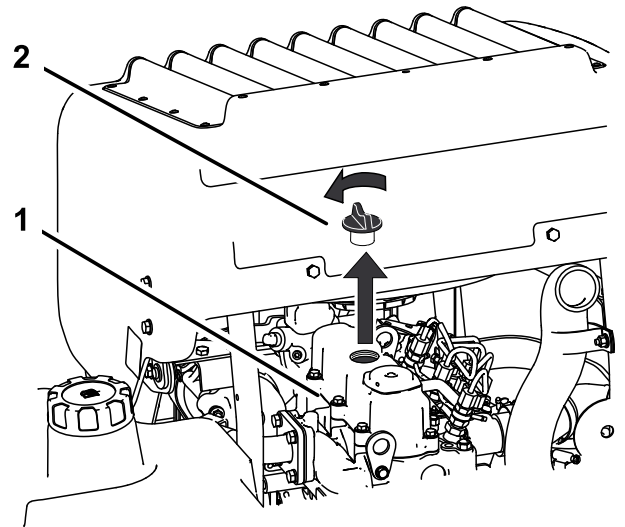

Figure 64

1. Engine
2. Oil-fill cap

3. Use a hose and funnel to add oil to the engine (Figure 65).
4. Add oil slowly, checking the level frequently with the dipstick until the level reaches the upper hole on the dipstick. For the correct oil type and viscosity to use in different temperature conditions, refer to [Engine-Oil Specifications](#) (page 47).

Fuel System Maintenance

⚠ DANGER

In certain conditions, fuel is extremely flammable and highly explosive. A fire or explosion from fuel can burn you and others and can damage property.

Refer to [Adding Fuel \(page 18\)](#) for a complete list of fuel related precautions.

Servicing the Fuel Filter and Water Separator

Service Interval: Every 40 hours—Drain the water separator.

Every 400 hours/Yearly (whichever comes first)—Replace the fuel filter (more often in dirty or dusty conditions).

Draining the Water Separator

1. Park the machine on a level surface, disengage the blade-control switch, and engage the parking brake.
2. Shut off the engine, remove the key, and wait for all moving parts to stop before leaving the operating position.
3. Locate the water separator at the back left of the machine.
4. Place a drain pan below the water separator.
5. Open the drain valve on the water separator approximately 1 turn to allow water and other contaminants to drain ([Figure 67](#)).
6. Close the drain valve when only diesel fuel comes out ([Figure 67](#)).

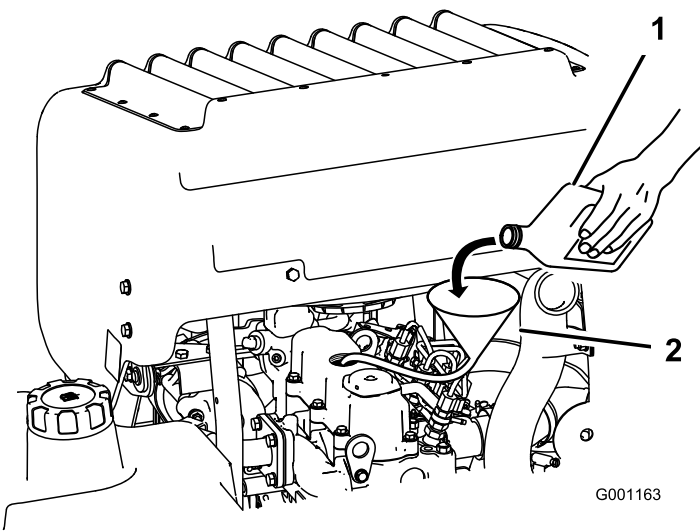

Figure 65

1. Engine oil
2. Funnel and hose

Important: Add the oil very slowly and do not block the opening of the filler hole ([Figure 66](#)). If you add oil too fast or block the hole, the oil could back up and foul the air intakes, causing engine damage.

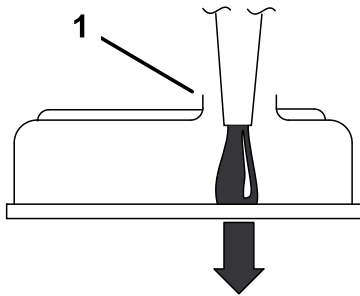
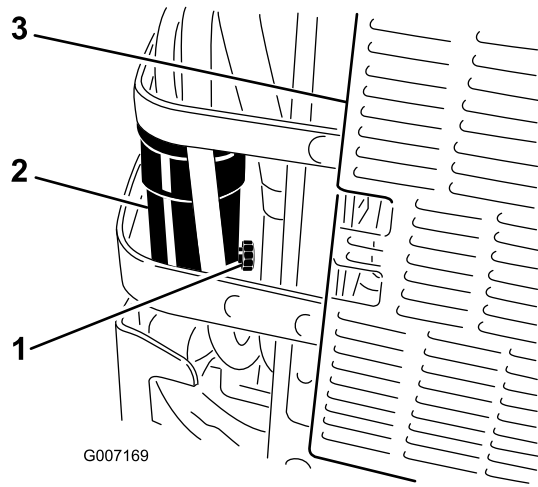

Figure 66

1. Note the clearance left in the filler opening.
5. Replace the dipstick and install the front engine panel.
6. Start the engine and run it at idle for 5 minutes.
7. Shut off the engine.
8. Wait 3 minutes and check the oil level.
9. Add oil, if required, to bring the level to the upper hole on the dipstick.
10. Replace the dipstick, filler cap, and the front engine panel.
11. Check for leaks.

Important: Do not overfill the crankcase with oil because this may cause engine damage.



G007169

Figure 67

g007169

- | | |
|--------------------|--------------------|
| 1. Drain valve | 3. Back of machine |
| 2. Water separator | |

Changing the Fuel Filter

Never install a dirty fuel filter if it is removed from the fuel line.

1. Allow the machine to cool down.
2. Park the machine on a level surface, disengage the blade-control switch, and engage the parking brake.
3. Shut off the engine, remove the key, and wait for all moving parts to stop before leaving the operating position.
4. Close the fuel shut-off valve ([Figure 68](#)).
5. Loosen the 2 hose clamps and disconnect the fuel lines from the fuel filter ([Figure 68](#)).
6. Install a new filter. Connect the fuel lines to the fuel filter and install the 2 hose clamps ([Figure 68](#)).
7. Open the fuel shut-off valve.
8. Start the engine and check for leaks.

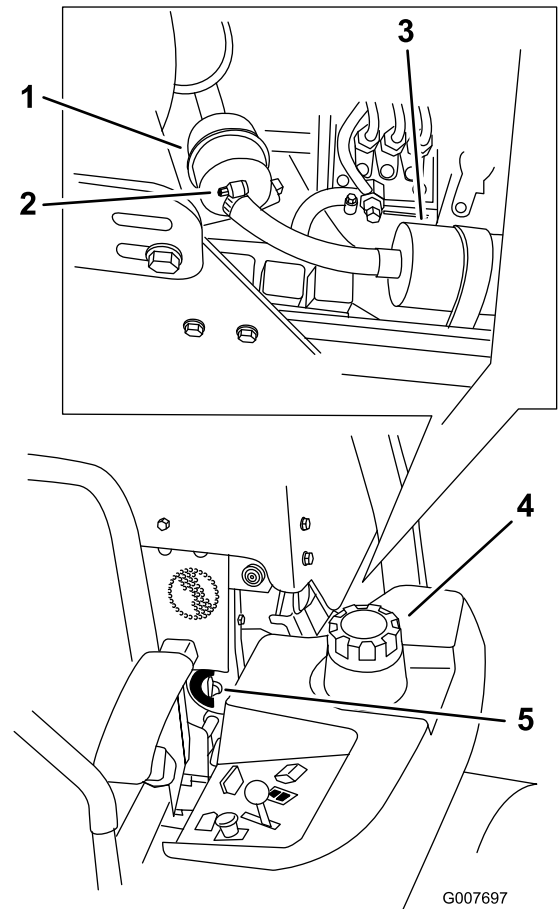

G007697

Figure 68

g007697

- | | |
|----------------|-------------------------|
| 1. Fuel filter | 4. Left side of machine |
| 2. Hose clamp | 5. Fuel-shutoff valve |
| 3. Fuel pump | |

Servicing the Fuel Tank

Do not attempt to drain the fuel tank. Ensure that an Authorized Service Dealer drains the fuel tank and services any components of the fuel system.

Electrical System Maintenance

Electrical System Safety

- Disconnect the battery before repairing the machine. Disconnect the negative terminal first and the positive last. Connect the positive terminal first and the negative last.
- Charge the battery in an open, well-ventilated area, away from sparks and flames. Unplug the charger before connecting or disconnecting the battery. Wear protective clothing and use insulated tools.

Servicing the Battery

Service Interval: Monthly

Removing the Battery

⚠ WARNING

Battery terminals or metal tools could short against metal machine components causing sparks. Sparks can cause the battery gasses to explode, resulting in personal injury.

- When removing or installing the battery, do not allow the battery terminals to touch any metal parts of the machine.
- Do not allow metal tools to short between the battery terminals and metal parts of the machine.

⚠ WARNING

Incorrectly removing the cables from battery could damage the machine and cables, causing sparks. Sparks can cause the battery gasses to explode, resulting in personal injury.

- Always disconnect the negative (black) battery cable before disconnecting the positive (red) cable.
- Always connect the positive (red) battery cable before connecting the negative (black) cable.

1. Park the machine on a level surface, disengage the blade-control switch (PTO), and engage the parking brake.

2. Shut off the engine, remove the key, and wait for all moving parts to stop before leaving the operating position.
3. Remove the battery as shown in [Figure 69](#).

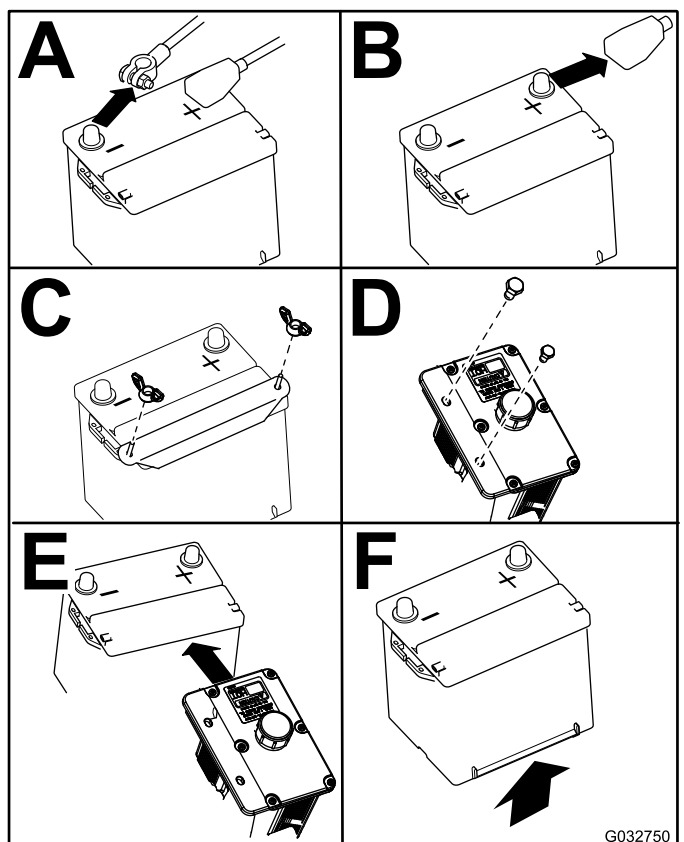

Figure 69

Charging the Battery

⚠ WARNING

Charging the battery produces gasses that can explode.

Never smoke near the battery and keep sparks and flames away from the battery.

Important: Always keep the battery fully charged (1.265 specific gravity). This is especially important to prevent battery damage when the temperature is below 0°C (32°F).

1. Remove the battery from the chassis; refer to [Removing the Battery \(page 53\)](#).
2. Charge the battery for 10 to 15 minutes at 25 to 30 A or for 30 minutes at 10 A.

Note: Do not overcharge the battery.

3. When the battery is fully charged, unplug the charger from the electrical outlet, then disconnect the charger leads from the battery posts ([Figure 70](#)).
4. Install the battery in the machine and connect the battery cables; refer to [Installing the Battery \(page 54\)](#).

Note: Do not run the machine with the battery disconnected; electrical damage may occur.

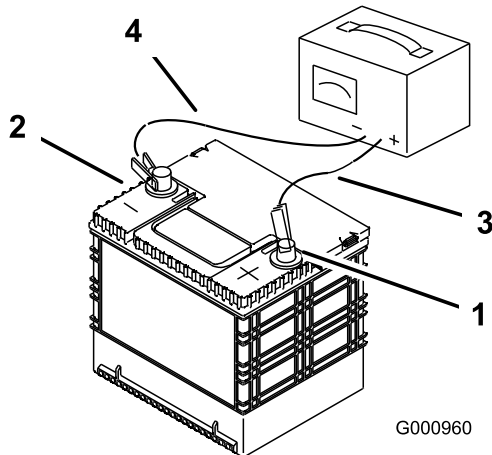

Figure 70

1. Positive (+) battery post
2. Negative (-) battery post
3. Red (+) charger lead
4. Black (-) charger lead

Installing the Battery

Note: Position the battery in the tray with the terminal posts opposite from the hydraulic tank ([Figure 71](#)).

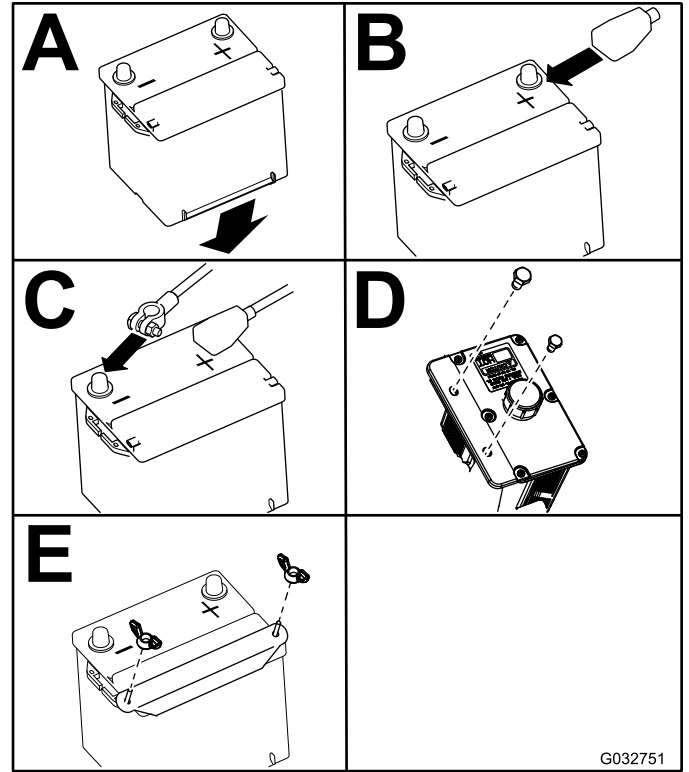

Figure 71

Servicing the Fuses

The electrical system is protected by fuses. It requires no maintenance, however, if a fuse blows check component/circuit for malfunction or short.

1. Unlatch the engine hood and raise the engine hood to gain access to fuse holder (Figure 72).
2. To replace the fuses, pull out on the fuse to remove it.
3. Install a new fuse (Figure 72).

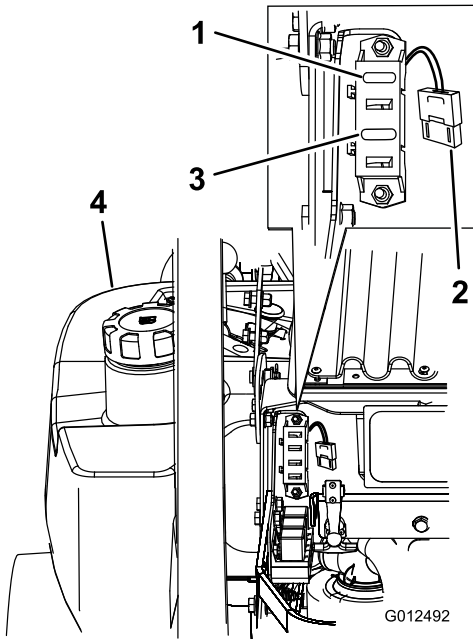

Figure 72

- | | |
|---|---------------------|
| 1. Ignition—30 A (F1) | 3. Clutch—10 A (F3) |
| 2. Radiator fan—50 A (large, heavy duty fuse) | 4. Left fuel tank |

Drive System Maintenance

Checking the Seat Belt

Service Interval: Before each use or daily

Inspect the seat belt for wear, cuts, and proper operation of the retractor and buckle. Replace the seat belt if it is damaged.

Adjusting the Tracking

The machine has a knob for adjusting the tracking located under the seat.

Important: Adjust the handle neutral and hydraulic pump neutral before adjusting the tracking; refer to [Adjusting the Control Handle Neutral Position \(page 66\)](#) and [Setting the Hydraulic Pump Neutral Position \(page 69\)](#).

1. Disengage the blade-control switch (PTO).
2. Drive to an open flat area, move the motion-control levers to the NEUTRAL-LOCK position.
3. Move the throttle midway between the FAST and SLOW positions.
4. Push both control levers forward the same distance.
5. Check which way the machine tracks.
6. Engage the parking brake, shut off the engine, and remove the key.
7. Unlatch the seat and tilt the seat forward to access the tracking knob.
8. Adjust the tracking knob as needed.

Note: Determine the left and right sides of the machine from the normal operating position.

- If the machine tracks to the right, turn the knob toward the left of the machine; refer to [Figure 73](#).
 - If the machine tracks to the left, turn the knob toward the right of the machine; refer to [Figure 73](#).
9. Repeat adjustment until the tracking is correct.

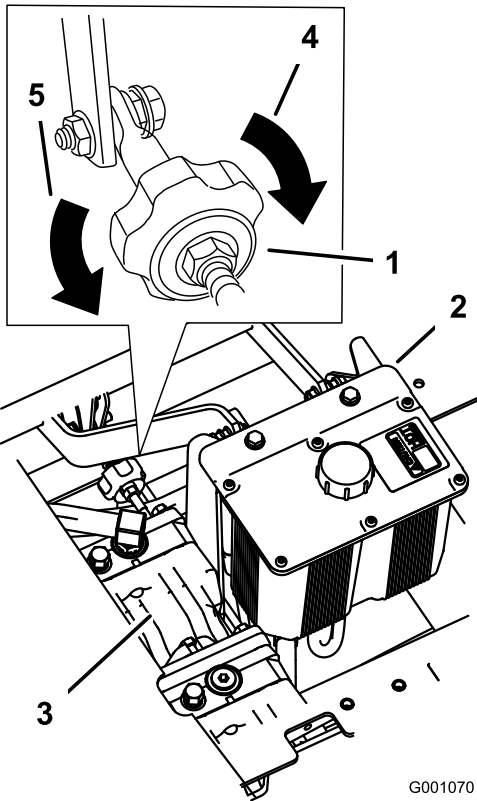

Figure 73

- | | |
|--------------------|----------------------------------|
| 1. Tracking knob | 4. Turn this way to track right. |
| 2. Hydraulic tank | 5. Turn this way to track left. |
| 3. Hydraulic pumps | |

Checking the Tire Pressure

Service Interval: Every 50 hours/Monthly (whichever comes first)

Maintain the air pressure in the front and rear tires at 90 kPa (13 psi). Uneven tire pressure can cause uneven cut. Check the tires when they are cold to get the most accurate pressure reading.

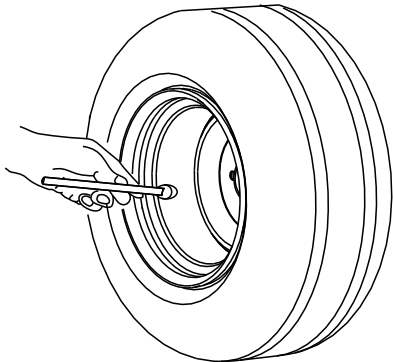

Figure 74

Checking the Wheel Lug Nuts

Check and torque the wheel lug nuts to 122 to 129 N·m (90 to 95 ft-lb).

Torquing the Wheel Hub Castle Nut

Service Interval: After the first 100 hours

Every 500 hours thereafter

1. Remove the cotter pin.
2. Torque the castle nut to 319 N·m (235 ft-lb).
3. Continue to tighten the nut slowly until the next slot aligns with the cross hole in the wheel motor shaft.
4. Insert the cotter pin and bend 1 tine over the end of the shaft.

Note: Do not use anti-seize on the wheel hub.

Adjusting the Caster-Pivot Bearing

Service Interval: Every 500 hours/Yearly (whichever comes first)

1. Park the machine on a level surface, disengage the blade-control switch (PTO), and engage the parking brake.
 2. Shut off the engine, remove the key, and wait for all moving parts to stop before leaving the operating position.
 3. Remove the dust cap from caster and tighten the locknut (Figure 75).
 4. Tighten the locknut until the spring washers are flat, and then back off a 1/4 turn to properly set the preload on the bearings (Figure 75).
- Important:** Make sure that the spring washers are installed correctly as shown in Figure 75.
5. Install the dust cap (Figure 75).

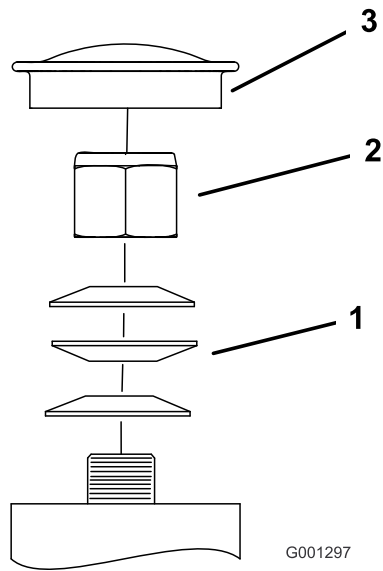

Figure 75

- | | |
|-------------------|-------------|
| 1. Spring washers | 3. Dust cap |
| 2. Locknut | |

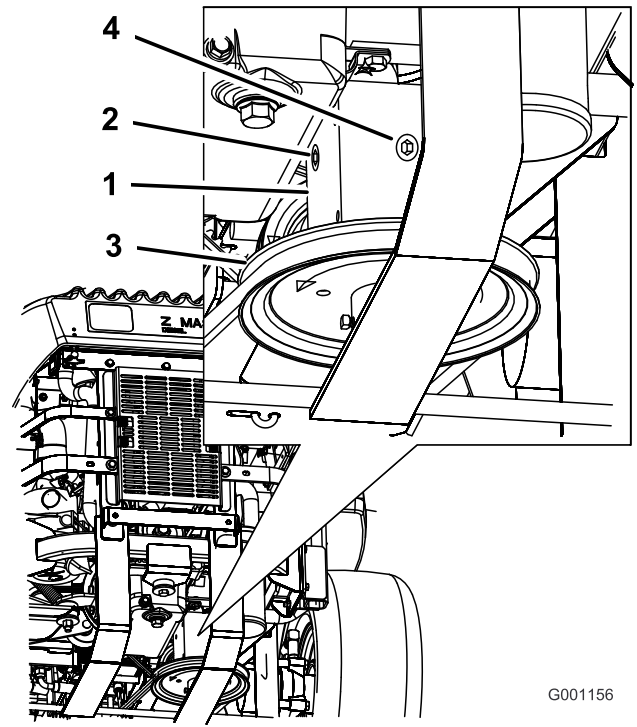

Figure 76

- | | |
|--------------|--------------|
| 1. Gearbox | 3. Pulley |
| 2. Side plug | 4. Rear plug |

Servicing the Gearbox

Checking the Gearbox-Oil Level

Service Interval: Every 100 hours

Use SAE 75W-90 synthetic gear lube.

1. Park the machine on a level surface, disengage the blade-control switch, and engage the parking brake.
2. Shut off the engine, remove the key, and wait for all moving parts to stop before leaving the operating position.
3. Remove the side or rear plug on the gearbox ([Figure 76](#)).
4. The oil should be up to the opening of the gearbox.
5. Add oil if needed to bring it to the correct level.

Changing the Gearbox Oil

Service Interval: After the first 100 hours

Yearly

Contact an Authorized Service Dealer to change the gearbox oil.

Adjusting the Electric Clutch

Service Interval: Every 500 hours

The clutch is adjustable to ensure proper engagement and proper braking.

1. Park the machine on a level surface, disengage the blade-control switch, and engage the parking brake.
2. Shut off the engine, remove the key, and wait for all moving parts to stop before leaving the operating position.
3. Unlatch the seat and tip it forward.
4. Loosen the front engine panel knobs and remove the panel.
5. Pull up on the spring-loaded idler pulley for the PTO-drive belt and remove the belt from the clutch pulley (Figure 77).

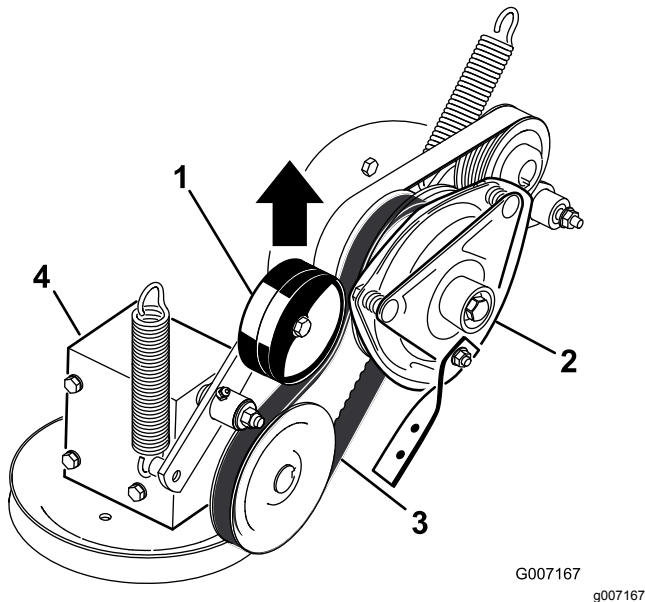

Figure 77

- | | |
|-------------------------------|-------------------|
| 1. Spring-loaded idler pulley | 3. PTO-drive belt |
| 2. Clutch | 4. Gearbox |

6. Unplug the electric connection for the clutch (Figure 78).
7. Remove the 2 bolts holding the rubber clutch strap to the mower frame (Figure 78).
8. Remove the center bolt holding the clutch to the engine shaft and remove the clutch and key (Figure 78).

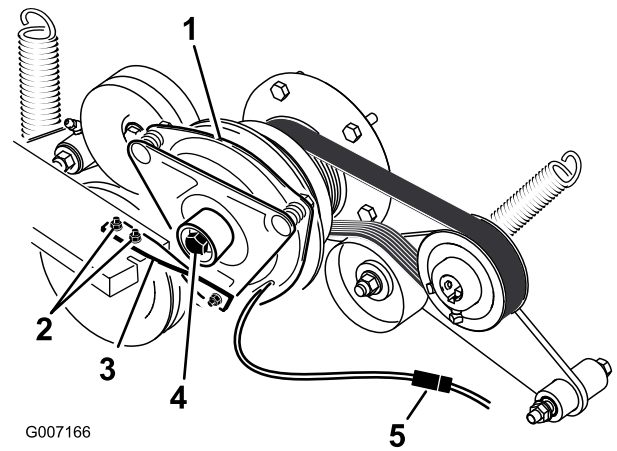

Figure 78

- | | |
|--------------------------------|--------------------------------|
| 1. Clutch | 4. Clutch center bolt |
| 2. 2 bolts and nuts for clutch | 5. Electrical connection strap |
| 3. Rubber clutch strap | |

9. Insert a 0.381 to 0.533 mm (0.015 to 0.021 inch) feeler gauge through an inspection slot in the side of the assembly (Figure 79).

Note: Make sure that it is between the armature and the rotor friction surfaces.

10. Tighten the locknuts until there is slight binding on the feeler gauge but it can be moved easily within the air gap (Figure 79).
11. Repeat this for the remaining slots.
12. Check each slot again and make slight adjustments until the feeler gauge between the rotor and armature has very slight contact between them.

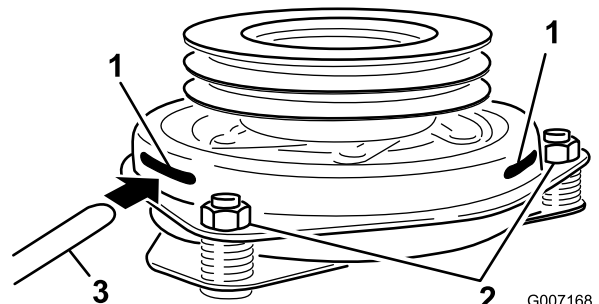

Figure 79

- | | |
|------------------|-----------------|
| 1. Slot | 3. Feeler gauge |
| 2. Adjusting nut | |

13. Install the clutch to the engine shaft with the key.
14. Apply thread-locking adhesive to the center bolt.
15. While holding the crank shaft at the back of the machine, install the center bolt and torque it to 68 N·m (50 ft·lb) (Figure 78).

16. Install the rubber clutch strap to the mower frame with the 2 previously removed bolts and nuts (Figure 78).
17. Pull up on the spring-loaded idler for the PTO-drive belt and install it onto the clutch pulley (Figure 77).
18. Plug in the electric connection for the clutch (Figure 78).
19. Install the front engine panel and tighten the knobs.
20. Lower down the seat.

Cooling System Maintenance

⚠ DANGER

The rotating shaft and fan can cause personal injury.

- Do not operate the machine without the covers in place.
- Keep your fingers, hands, and clothing clear of rotating fan and driveshaft.
- Shut off the engine and remove the ignition key before performing maintenance.

Checking the Engine-Coolant Level

Service Interval: Before each use or daily

After the first 8 hours

Every 100 hours

Fluid Type: 50/50 mix of extended life antifreeze/Dex-Cool® and water

Cooling System Capacity: 4.6 L (156 fl oz)

Note: Do not open the radiator cap. Doing this may induce air into the cooling system.

1. Park the machine on a level surface, disengage the blade-control switch, and engage the parking brake.
2. Shut off the engine, remove the key, and wait for all moving parts to stop before leaving the operating position.
3. Unlatch the seat and tilt the seat up.
4. With the engine cool, check the overflow bottle level. The fluid needs to be up to the bump on the outside of the overflow bottle (Figure 80).
5. If the coolant level is low, add a 50/50 mix of extended life antifreeze/Dex-Cool® and water to the overflow bottle (Figure 80).
6. Add the 50/50 coolant mix to the overflow bottle and fill it to the indicator line on the bottle (Figure 80).

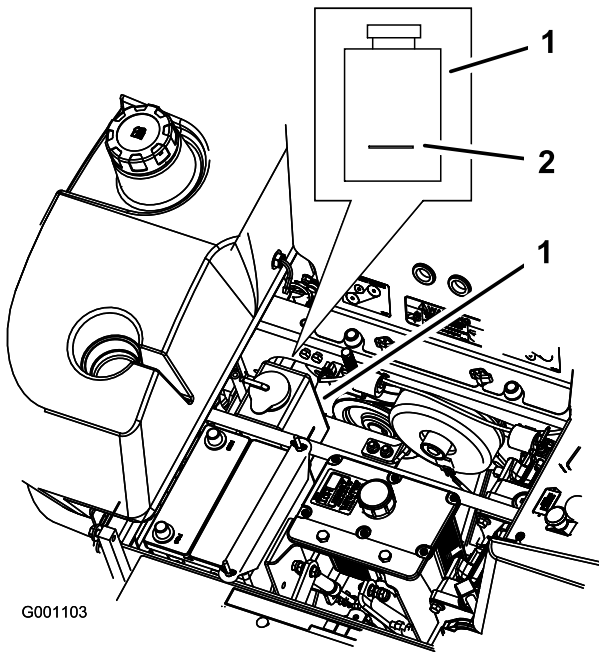

G001103

g001103

Figure 80

1. Antifreeze overflow bottle
2. Indicator line on side of overflow bottle

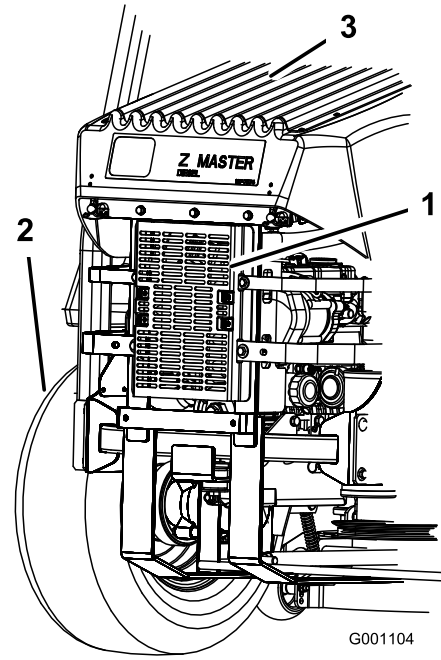

G001104

g001104

Figure 81

1. Hydraulic-fluid cooler
2. Left rear tire
3. Radiator screen

Cleaning the Hydraulic-Fluid Cooler and Radiator Screen

Service Interval: Before each use or daily

Before each use, check and clean the radiator screen and oil cooler. Remove any buildup of grass, dirt or other debris from the oil cooler and radiator screen with compressed air ([Figure 81](#)).

Changing the Engine Coolant

Service Interval: Yearly

Contact an Authorized Service Dealer for changing the coolant.

Brake Maintenance

Adjusting the Parking Brake

Service Interval: Every 25 hours

Every 200 hours

1. Park the machine on a level surface, disengage the blade-control switch (PTO), and engage the parking brake.
2. Shut off the engine, remove the key, and wait for all moving parts to stop before leaving the operating position.
3. Measure the length of the spring (Figure 82).

Note: The measurement should be 64 mm (2-1/2 inches) between the washers.

4. If adjustment is necessary, disengage the parking brake, loosen the jam nut below the spring and adjust the nut directly below the spring (Figure 82).
 5. Turn the nut until the correct measurement is obtained.
- Note:** Turn the nut clockwise to shorten spring length and turn counter-clockwise to lengthen the spring.
6. Tighten the 2 nuts together.
 7. Engage the parking brake and check the measurement of the spring again.
 8. If an adjustment is necessary, repeat the procedures above.
 9. Repeat on the opposite side of machine.

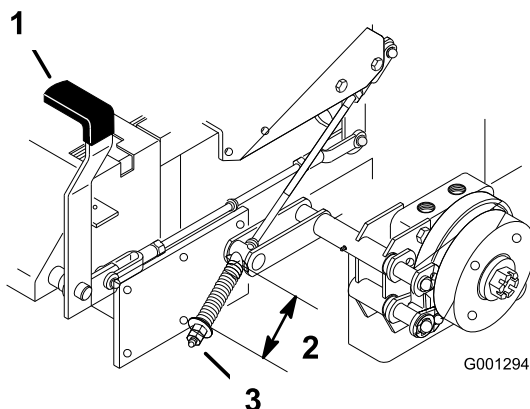

Figure 82

1. Brake lever in engaged position
2. Spring—64 mm (2-1/2 inches)
3. Adjusting nut and jam nut

Belt Maintenance

Inspecting the Belts

Service Interval: Every 100 hours

Replace the belt if it is worn. The signs of a worn belt include squealing while the belt is rotating; the blades slipping while cutting grass; and frayed edges, burn marks, and cracks on the belt.

Replacing the Mower Belt

Side-Discharge Machines

1. Park the machine on a level surface, disengage the blade-control switch, and engage the parking brake.
2. Shut off the engine, remove the key, and wait for all moving parts to stop before leaving the operating position.
3. Loosen the bottom bolt holding the mower-deck curtain to the mower deck; refer to [Releasing the Mower-Deck Curtain \(page 42\)](#).
4. Remove the sheet-metal guard; refer to [Removing the Sheet-Metal Guard \(page 42\)](#).
5. Remove the belt covers (Figure 83).

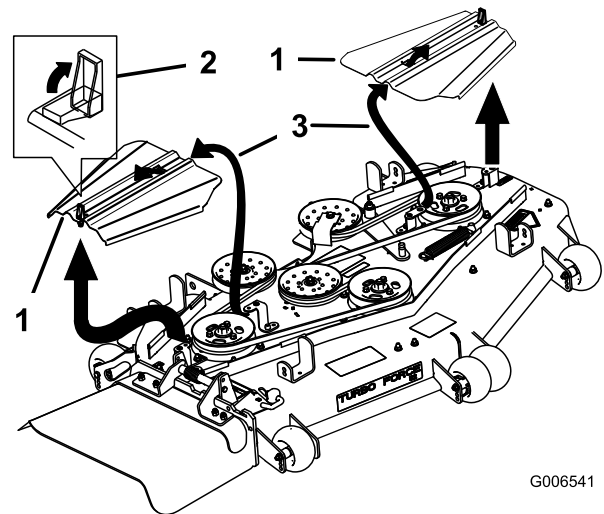

Figure 83

1. Belt cover
2. Latch
3. Insert slot into the tab

6. Remove the idler spring.
7. Remove the belt guide on the spring-loaded idler pulley shown in [Figure 84](#).
8. Remove the existing belt.

- Install the new belt around the mower pulleys and the gearbox pulley under the engine ([Figure 84](#)).

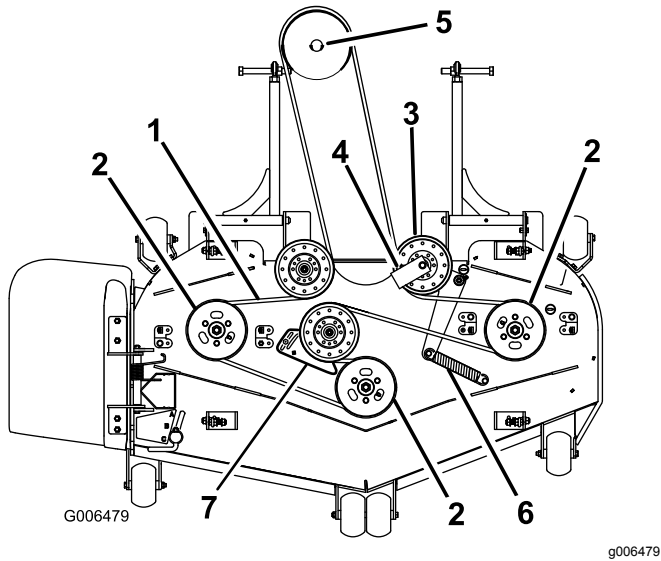

Figure 84

- | | |
|-------------------------------|--|
| 1. Mower belt | 5. Gearbox pulley |
| 2. Mower spindle pulley | 6. Idler spring |
| 3. Spring-loaded idler pulley | 7. Idler plate (for 72-inch mowers only) |
| 4. Belt guide at a 45° angle | |

- Install the belt guide on the spring-loaded idler at a 45° angle as shown in [Figure 84](#). Torque the bolt to 37 to 45 N·m (27 to 33 ft-lb).
- Install the idler spring to the 2 posts ([Figure 84](#)).
- Install the belt covers by sliding the cover into the tab, install the bolts, and close the latches ([Figure 85](#)).

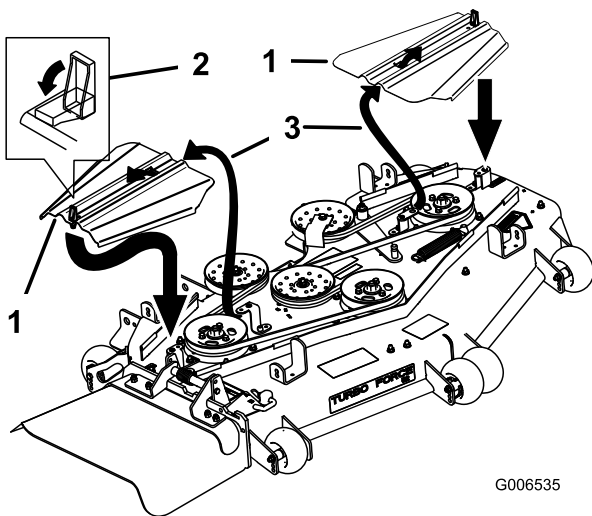

Figure 85

- | | |
|---------------|-----------------------------|
| 1. Belt cover | 3. Insert slot into the tab |
| 2. Latch | |

- Install the sheet-metal guard.
- Tighten the bottom bolt holding the mower-deck curtain to the mower deck.

Rear Discharge Machines

Important: The fasteners on the covers of this machine are designed to remain on the cover after removal. Loosen all of the fasteners on each cover a few turns so that the cover is loose but still attached, then go back and loosen them until the cover comes free. This prevents you from accidentally stripping the bolts free of the retainers.

- Park the machine on a level surface, disengage the blade-control switch, and engage the parking brake.
- Shut off the engine, remove the key, and wait for all moving parts to stop before leaving the operating position.
- Loosen the bottom bolt holding the mower-deck curtain to the mower deck; refer to [Releasing the Mower-Deck Curtain \(page 42\)](#).
- Remove the sheet metal guard; refer to [Removing the Sheet-Metal Guard \(page 42\)](#)
- Remove the belt covers and the bolts attached to them.
- Loosen the fixed idler arm and adjust it to relieve belt tension ([Figure 86](#)).
- Remove the old belt.
- Install the new belt on the pulleys.
- Insert a ratchet with a short extension or a breaker bar into the square hole in the fixed idler arm ([Figure 86](#)).
- Adjust the mower deck to the 76 mm (3 inch) height-of-cut position.
- To increase the belt tension, rotate the ratchet or breaker bar counterclockwise to move the fixed idler arm until there is 16.5 cm (6-1/2 inches) between the spring hooks ([Figure 86](#)).

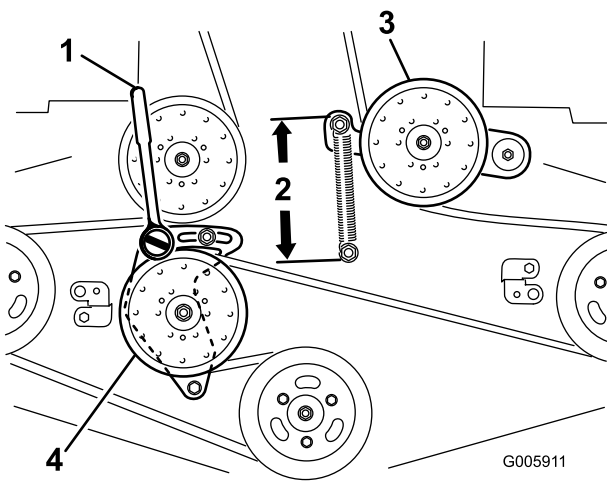

Figure 86

- | | |
|--|-------------------------------|
| 1. Ratchet with short extension or breaker bar | 3. Spring-loaded idler pulley |
| 2. 16.5 cm (6-1/2 inches) between the spring hooks | 4. Fixed Idler pulley |

12. While holding the belt in tension, tighten the 2 bolts that secure the fixed idler arm.
13. Remove the ratchet or breaker bar from the square hole in the fixed idler arm.
14. Install the belt covers with the tabs in the slots. Install the screws and close the latches (Figure 87).

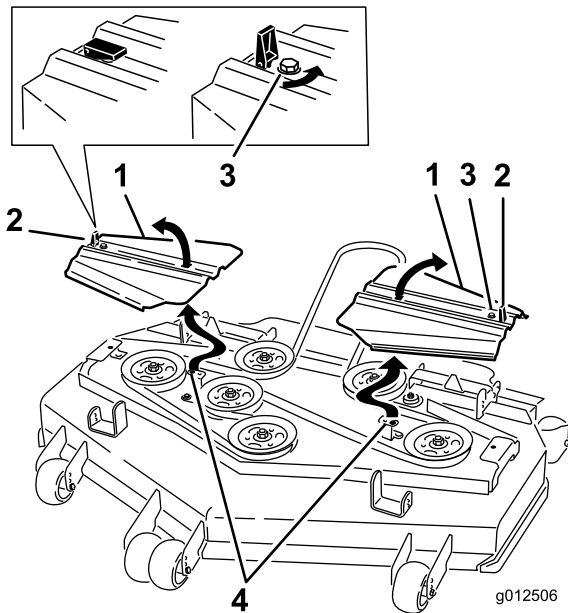

Figure 87

- | | |
|---------------|------------------------------|
| 1. Belt cover | 3. Bolt |
| 2. Latch | 4. Install tab into the slot |

15. Install the sheet-metal guard; refer to [Removing the Sheet-Metal Guard \(page 42\)](#).

16. Tighten the bolt for the mower-deck curtain; refer to [Releasing the Mower-Deck Curtain \(page 42\)](#).
17. Check the tension on the drive belts.

Replacing the PTO-Drive Belt

Service Interval: Every 50 hours—Check the PTO-drive belt.

1. Park the machine on a level surface, disengage the blade-control switch, and engage the parking brake.
2. Shut off the engine, remove the key, and wait for all moving parts to stop before leaving the operating position.
3. Loosen the front engine panel knobs and remove the panel (Figure 88).

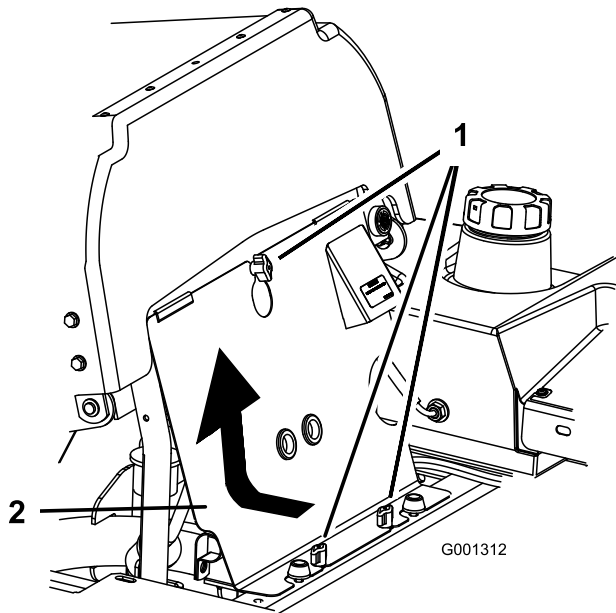

Figure 88

1. Knob
2. Front engine panel

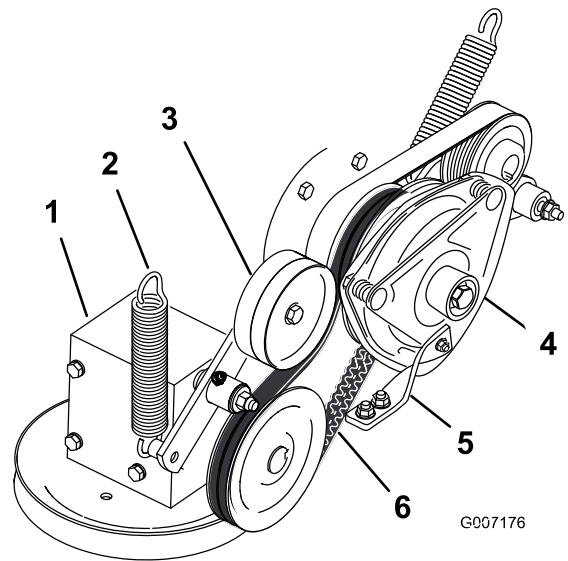

Figure 89

1. Gearbox
2. Spring
3. Spring-loaded idler pulley
4. Clutch
5. Rubber clutch stop
6. PTO-drive belt

4. Remove the spring from the idler arm (Figure 89).
5. Remove the clutch stop bracket.
6. Remove the old PTO-drive belt.
7. Install the PTO-drive belt around the clutch pulley and the gearbox pulley (Figure 89).
8. Install the rubber clutch stop.
9. Install the spring to the idler arm (Figure 89).

Replacing the Pump-Drive Belt

Service Interval: Every 50 hours—Check the pump-drive belt.

Note: Remove the PTO-drive belt first if the pump-drive belt needs to be replaced.

1. Tilt the seat forward and remove the front engine panel.
2. Remove the PTO-drive belt.
3. Remove the spring from the idler arm (Figure 90).
4. Install the new belt around the engine and hydraulic pump pulley (Figure 90).
5. Install the PTO-drive belt.
6. Install the spring to the idler arm (Figure 90).

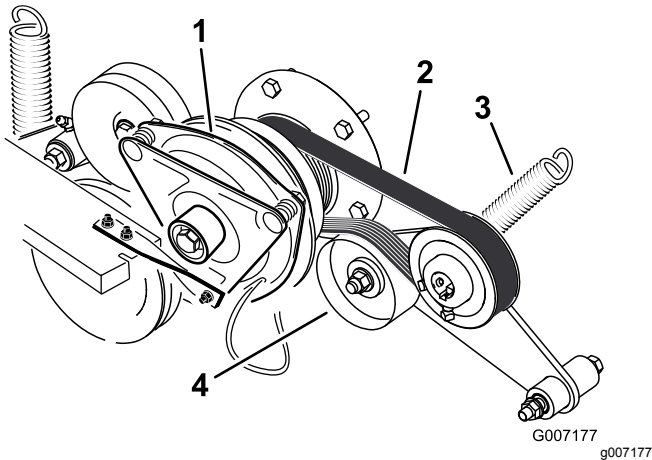

Figure 90

- | | |
|--------------------|-------------------------------|
| 1. Clutch | 3. Spring |
| 2. Pump-drive belt | 4. Spring-loaded idler pulley |

2. Adjust the alternator to the outside until there is 7 to 9 mm (1/4 to 11/32 inch) deflection in the belt between the engine and the alternator pulleys with 10 kg (22.1 lb) of force (Figure 91).
3. Tighten the alternator bolts.
4. Check the deflection in the belt again and adjust the belt if needed.
5. If the deflection is correct, tighten the bottom and upper bolt (Figure 91).

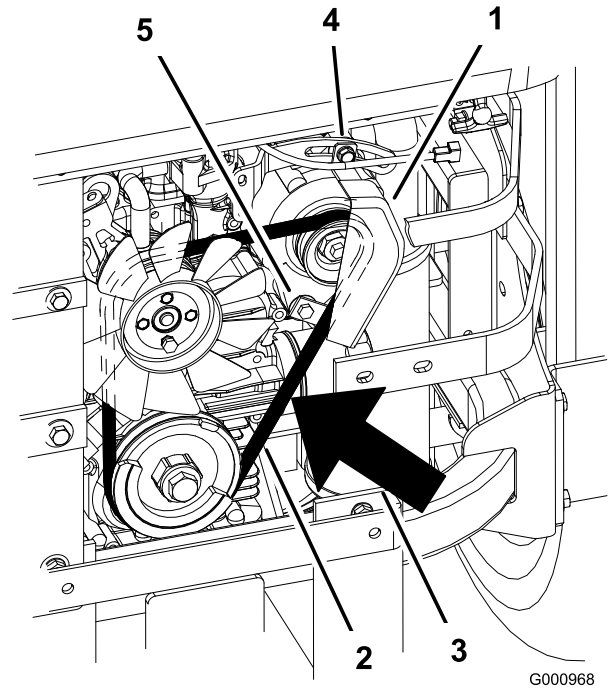

Figure 91

- | | |
|---|----------------|
| 1. Alternator | 4. Top bolt |
| 2. Alternator belt | 5. Bottom bolt |
| 3. Deflection—7 to 9 mm (1/4 to 11/32 inch) with 10 kg (22.1 lb) of force | |

Replacing and Tensioning the Alternator Belt

Replacing the Alternator Belt

Service Interval: Every 50 hours—Check the alternator belt.

If the alternator belt needs to be replaced, take your machine to an Authorized Service Dealer.

Tensioning the Alternator Belt

1. Place a handle between the alternator and cylinder block.

Checking the Alternator-Belt Tension

Service Interval: Every 100 hours

1. Apply 44 N (10 lb) of force to the alternator belt, midway between the pulleys.
2. If the deflection is not 10 mm (3/8 inch), loosen the alternator mounting bolts (Figure 92).

Controls System Maintenance

Adjusting the Control Handle Neutral Position

If the motion-control levers do not align or move easily into the console notch, adjust the levers. Adjust each lever, spring, and rod separately.

Note: The motion-control levers must be installed correctly.

1. Park the machine on a level surface, disengage the blade-control switch, and engage the parking brake.
2. Shut off the engine, remove the key, and wait for all moving parts to stop before leaving the operating position.
3. Unlatch the seat and tilt the seat forward.
4. Begin with either the left or right motion-control lever.
5. Move the lever to the neutral position but not locked (Figure 93).
6. Pull the lever back until the clevis pin (on arm below pivot shaft) contacts the end of the slot (just beginning to put pressure on the spring) as shown in Figure 93.
7. Check where the control lever is relative to the notch in the console (Figure 93).

Note: Center the lever so that it pivots outward to the NEUTRAL-LOCK position.

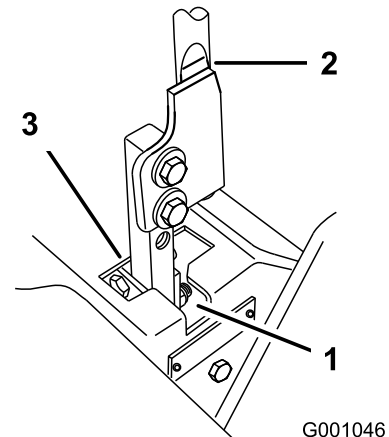

Figure 93

1. NEUTRAL-LOCK position
2. Control lever
3. NEUTRAL position

8. If adjustment is needed, loosen the nut and jam nut against the yoke (Figure 94).

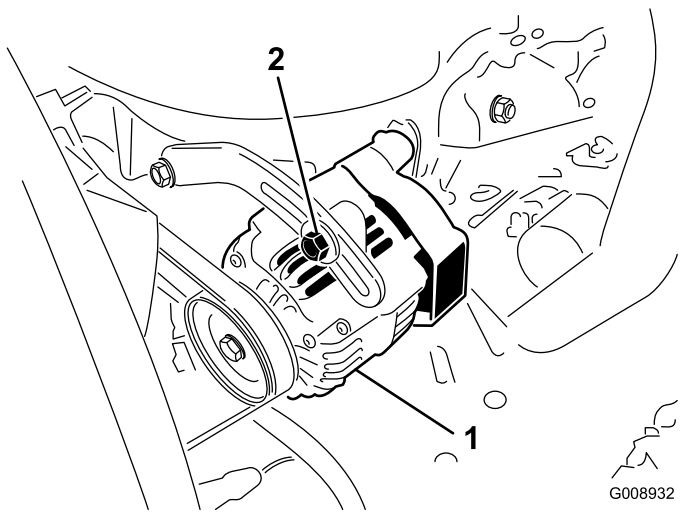

Figure 92

1. Mounting bolt
2. Alternator

3. Increase or decrease the alternator-belt tension.
4. Tighten the mounting bolts.
5. Check the deflection of the belt again to ensure that the tension is correct.

- While applying slight rearward pressure on the motion-control lever, turn the head of the adjustment bolt in the appropriate direction until the control lever is centered in the NEUTRAL-LOCK position (Figure 94).

Note: Keeping rearward pressure on the lever keeps the pin at the end of the slot and allows the adjustment bolt to move the lever to the appropriate position.

- Tighten the nut and jam nut (Figure 94).
- Repeat for the opposite side of the machine.

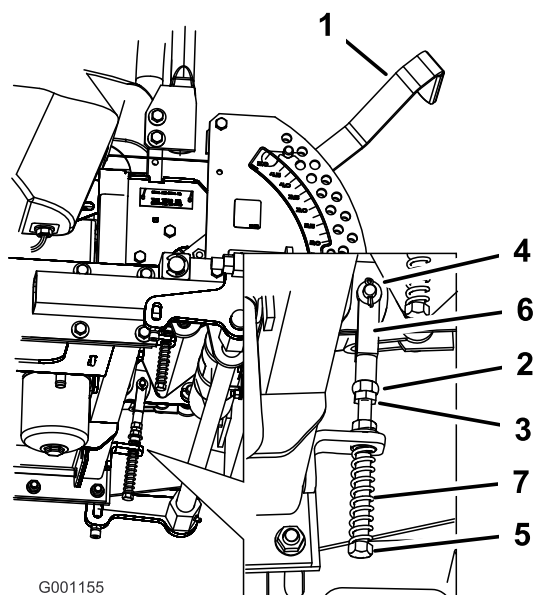

Figure 94

- | | |
|------------------------|--------------------|
| 1. Height-of-cut lever | 5. Adjustment bolt |
| 2. Nut against yoke | 6. Yoke |
| 3. Jam nut | 7. Spring |
| 4. Clevis pin in slot | |

Hydraulic System Maintenance

Hydraulic System Safety

- Seek immediate medical attention if fluid is injected into skin. Injected fluid must be surgically removed within a few hours by a doctor.
- Ensure that all hydraulic-fluid hoses and lines are in good condition and all hydraulic connections and fittings are tight before applying pressure to the hydraulic system.
- Keep your body and hands away from pinhole leaks or nozzles that eject high-pressure hydraulic fluid.
- Use cardboard or paper to find hydraulic leaks.
- Safely relieve all pressure in the hydraulic system before performing any work on the hydraulic system.

Hydraulic-Fluid Specifications

Hydraulic-Fluid Type: Toro® HYPR-OIL™ 500 hydraulic fluid or Mobil® 1 15W-50 fluid

Important: Use the specified fluid. Other fluids could damage the hydraulic system.

Hydraulic-System Fluid Capacity: 3.9 L (132 fl oz)

Checking the Hydraulic-Fluid Level

Service Interval: After the first 8 hours
Every 25 hours

Note: You can check the hydraulic fluid when the fluid is warm or it is cold. The baffle inside the tank has 2 levels depending if the fluid is warm or cold.

- Park the machine on a level surface, disengage the blade-control switch, and engage the parking brake.
- Shut off the engine, remove the key, and wait for all moving parts to stop before leaving the operating position.
- Clean the area around the filler neck of the hydraulic tank (Figure 95).
- Remove the cap from the filler neck and look inside to check if there is fluid in the reservoir (Figure 95).
- If there is no fluid, add fluid to the reservoir until it reaches the cold level of the baffle.

- Run the machine at low idle for 15 minutes to allow any air to purge out of the system and warm the fluid; refer to [Starting the Engine in Normal Weather](#) (page 26).

Note: Check the fluid level while the fluid is warm. The fluid should be between cold and hot.

- If required, add fluid to the hydraulic tank.

Note: The fluid level should be to the top of the hot level of the baffle, when the fluid is hot ([Figure 95](#)).

- Install the cap on the filler neck.

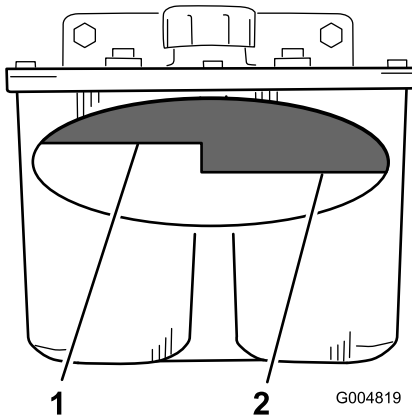

Figure 95

- Hot fluid level—full
- Cold fluid level—full

Changing the Hydraulic Fluid and Filter

Service Interval: After the first 25 hours

Every 250 hours—Change the hydraulic filter and hydraulic fluid when using Mobil® 1 fluid.

Every 500 hours—Change the hydraulic filter and hydraulic fluid when using Toro® HYPR-OIL™ 500 hydraulic fluid.

Use summer filter above 0°C (32°F)

Use winter filter below 0°C (32°F)

- Park the machine on a level surface, disengage the blade-control switch, and engage the parking brake.
- Shut off the engine, remove the key, and wait for all moving parts to stop before leaving the operating position.

Important: Do not substitute automotive oil filter or severe hydraulic system damage may result.

- Place drain pan under filter, remove the old filter and wipe the filter adapter gasket surface clean ([Figure 96](#)).

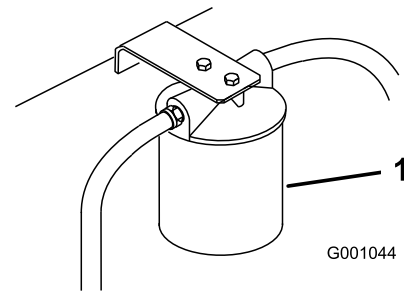

Figure 96

- Hydraulic filter

- Remove the right hydraulic line that comes into the adapter ([Figure 97](#)).
- Allow the fluid to drain out of the system into the drain pan.
- Install the right hydraulic line to the adapter ([Figure 97](#)).

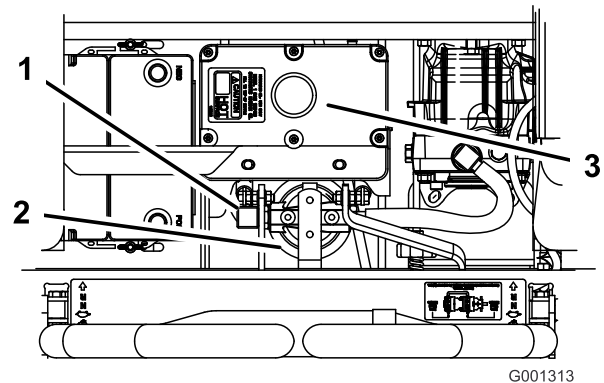

Figure 97

- Right hydraulic line
- Hydraulic filter
- Hydraulic tank

- Apply a thin coat to the rubber gasket on the replacement filter ([Figure 97](#)).
- Install the replacement hydraulic filter onto the filter adapter.

Note: Do not tighten.

- Fill the hydraulic tank with hydraulic fluid until the fluid overflows the filter and then turn the fluid filter clockwise until the rubber gasket contacts the filter adapter, then tighten the filter an additional 1/2 turn ([Figure 97](#)).
- Clean up any spilled fluid.
- Add fluid to the cold level of the baffle in the hydraulic tank.
- Start the engine and let it run for about 2 minutes to purge air from the system.
- Shut off the engine and check for leaks.

Note: If 1 or both wheels do not drive, refer to [Bleeding the Hydraulic System \(page 69\)](#).

14. Check the fluid level while the fluid is warm.

Note: The fluid should be between cold and hot.

15. If required, add fluid to the hydraulic tank.

Note: Do not overfill.

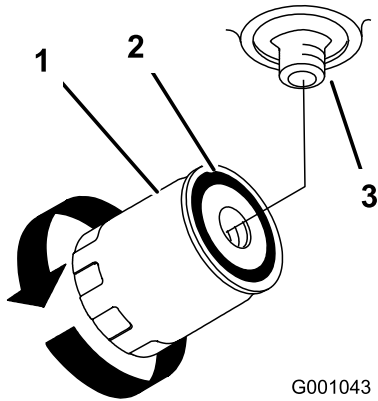

Figure 98

1. Hydraulic filter
2. Gasket
3. Adapter

Bleeding the Hydraulic System

The traction system is self-bleeding; however, it may be necessary to bleed the system if fluid is changed or after work is performed on the system.

1. Raise the rear of the machine so that the wheels are off the ground and support with jack stands.
2. Start the engine and run at low idle speed and engage the lever and traction on 1 side and spin the wheel by hand.
3. When the wheel begins to spin on its own, keep it engaged until the wheel drives smoothly (minimum 2 minutes).
4. Check the hydraulic-fluid level and add as required to maintain proper level.
5. Repeat this procedure on the opposite wheel.

Setting the Hydraulic Pump Neutral Position

Note: Adjust the handle neutral first. That needs to be correct before the following adjustment can be made.

This adjustment must be made with drive wheels turning.

⚠ DANGER

Mechanical or hydraulic jacks may fail to support the machine and cause a serious injury.

- Use a jack stand when supporting the machine.
- Do not use hydraulic jacks.

⚠ WARNING

The engine must be running so that you can adjust the motion control. Any contact with moving parts or hot surfaces may cause personal injury.

Keep your hands, feet, face, clothing and other body parts away from rotating parts, muffler and other hot surfaces.

1. Raise the frame and block up the machine so that the drive wheels can rotate freely.
2. Disconnect the electrical connector from the seat safety switch. Temporarily install a jumper wire across terminals in the wire-harness connector.
3. Unlatch the seat and slide seat forward.
4. Disconnect the seat rod and tilt the seat fully forward.

Setting the Right Hydraulic Pump Neutral Position

1. Start the engine, open the throttle 1/2 way and disengage parking brake; refer to [Starting the Engine in Normal Weather \(page 26\)](#).

Note: The motion-control lever must be in neutral while making any adjustments.

2. Adjust the pump rod length by rotating the knob, in the appropriate direction, until the wheel is still or slightly creeping in reverse ([Figure 99](#)).
3. Move the motion-control lever forward and reverse, then back to neutral.

Note: The wheel must stop turning or slightly creep in reverse.

- Open the throttle to FAST.

Note: Make sure that the wheel remains stopped or slightly creeps in reverse; adjust if necessary.

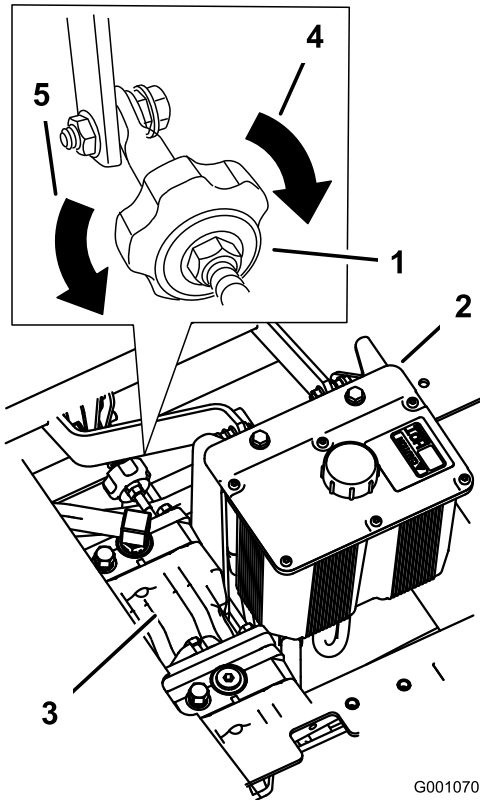

Figure 99

- | | |
|--------------------|---------------------------------|
| 1. Tracking knob | 4. Turn this way to track right |
| 2. Hydraulic tank | 5. Turn this way to track left |
| 3. Hydraulic pumps | |

Setting the Left Hydraulic Pump Neutral Position

- Loosen the locknuts at the ball joints on the pump control rod (Figure 100).
 - Start the engine, open the throttle 1/2 way and disengage parking brake; refer to [Starting the Engine in Normal Weather](#) (page 26).
- Note:** The motion-control lever must be in neutral while making any adjustments.
- Note:** The front nut on the pump rod has left-hand threads.
- Adjust the pump rod length by rotating double nuts on rod, in the appropriate direction, until wheel is still or slightly creeps in reverse (Figure 100).
 - Move the motion-control lever forward and reverse, then back to neutral. The wheel must stop turning or slightly creep in reverse.
 - Open the throttle to fast. Make sure that the wheel remains stopped or slightly creeps in reverse, adjust if necessary.
 - Tighten the locknuts at the ball joints (Figure 100).

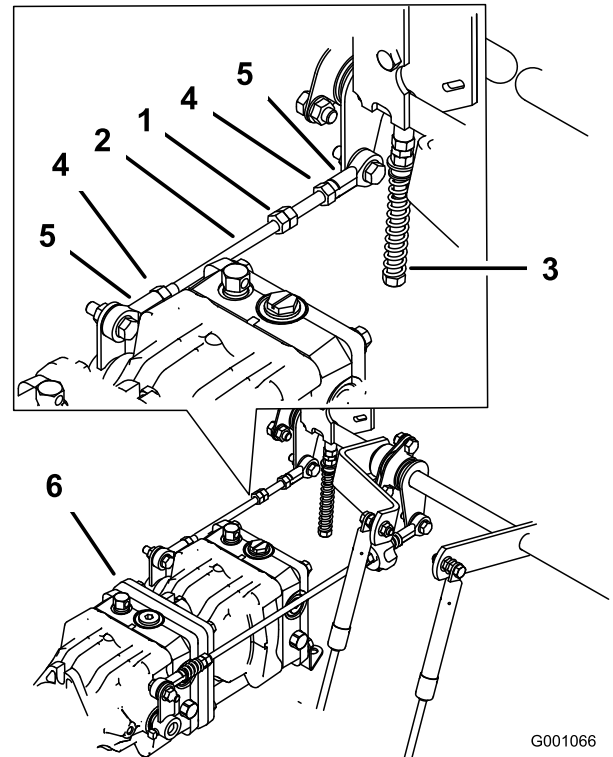

Figure 100

- | | |
|--------------------|---------------|
| 1. Double nuts | 4. Locknut |
| 2. Pump rod | 5. Ball joint |
| 3. Adjustment bolt | 6. Pumps |

⚠ WARNING

The electrical system does not perform proper safety shut off with the jumper wire installed.

- **Remove the jumper wire from the wire harness connector and plug the connector into the seat switch when you complete the adjustment.**
 - **Never operate the machine with the jumper installed and the seat switch bypassed.**
7. After both pump neutrals are set, shut off the machine.
 8. Remove the jumper wire from the wire harness connector and plug the connector into the seat switch.
 9. Install the seat rod and lower the seat into position.
 10. Remove the jack stands.

Mower Deck Maintenance

Blade Safety

A worn or damaged blade can break, and a piece of the blade could be thrown toward you or bystanders, resulting in serious personal injury or death. Trying to repair a damaged blade may result in discontinued safety certification of the product.

- Inspect the blades periodically for wear or damage.
- Use care when checking the blades. Wrap the blades or wear gloves, and use caution when servicing the blades. Only replace or sharpen the blades; never straighten or weld them.
- On multi-bladed machines, take care as rotating 1 blade can cause other blades to rotate.

Servicing the Cutting Blades

To ensure a superior quality of cut, keep the blades sharp. For convenient sharpening and replacement, you may want to keep extra blades on hand.

Before Inspecting or Servicing the Blades

1. Park the machine on a level surface, disengage the blade-control switch, and engage the parking brake.
2. Shut off the engine, remove the key, and wait for all moving parts to stop before leaving the operating position.

Inspecting the Blades

Service Interval: Before each use or daily

1. Inspect the cutting edges ([Figure 101](#)).
2. If the edges are not sharp or have nicks, remove and sharpen the blade; refer to [Sharpening the Blades \(page 73\)](#).
3. Inspect the blades, especially in the curved area.
4. If you notice any cracks, wear, or a slot forming in this area, immediately install a new blade ([Figure 101](#)).

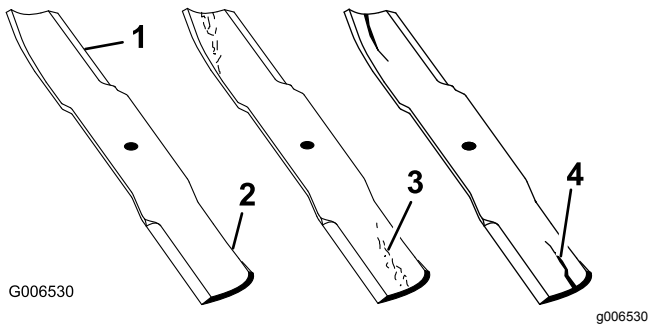

Figure 101

- 1. Cutting edge
- 2. Curved area
- 3. Wear/slot forming
- 4. Crack

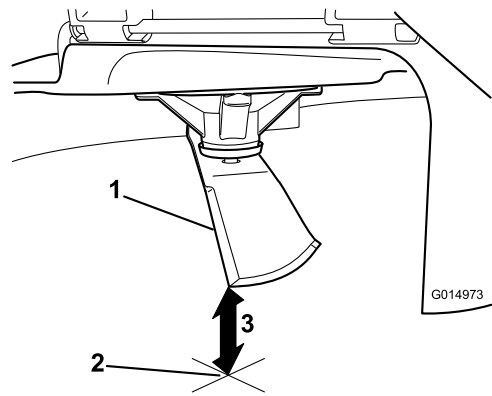

Figure 103

- 1. Blade (in position for measuring)
- 2. Level surface
- 3. Measured distance between blade and the surface (A)

Checking for Bent Blades

Note: The machine must be on a level surface for the following procedure.

1. Raise the mower deck to the highest height-of-cut position.
2. While wearing thickly padded gloves, or other adequate hand protection, slowly rotate the blade into a position that allows you to measure the distance between the cutting edge and the level surface the machine is on (Figure 102).

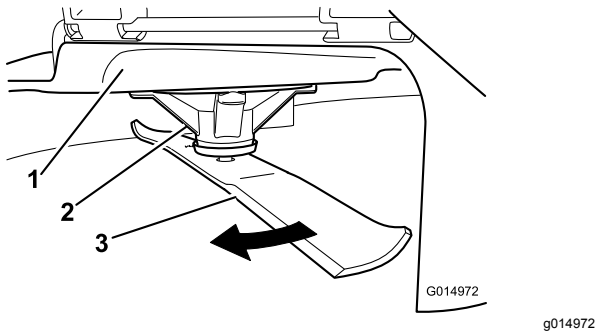

Figure 102

- 1. Deck
- 2. Spindle housing
- 3. Blade

3. Measure from the tip of the blade to the flat surface (Figure 103).

4. Rotate the same blade 180 degrees so that the opposing cutting edge is now in the same position (Figure 104).

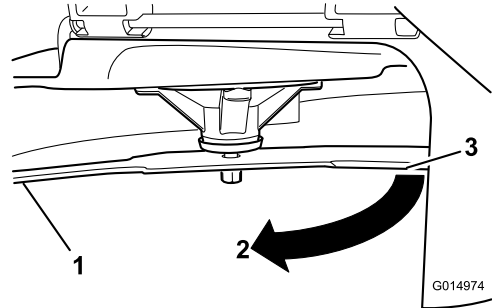

Figure 104

- 1. Blade (side previously measured)
- 2. Measurement (position used previously)
- 3. Opposing side of blade being moved into measurement position

5. Measure from the tip of the blade to the flat surface (Figure 105).

Note: The variance should be no more than 3 mm (1/8 inch).

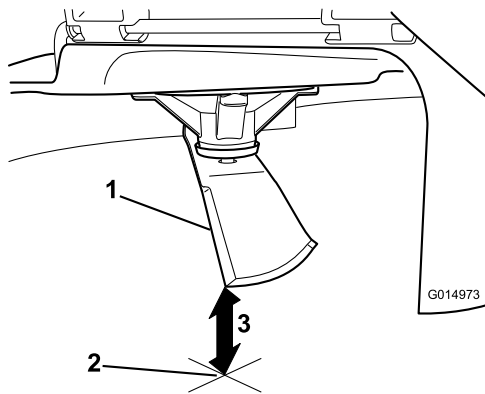

Figure 105

1. Opposite blade edge (in position for measuring)
2. Level surface
3. Second measured distance between blade and surface (B)

A. If the difference between A and B is greater than 3 mm (1/8 inch), replace the blade with a new blade; refer to [Removing the Blades \(page 73\)](#) and [Installing the Blades \(page 74\)](#).

Note: If a bent blade is replaced with a new blade, and the dimension obtained continues to exceed 3 mm (1/8 inch), the blade spindle could be bent. Contact an Authorized Service Dealer for service.

B. If the variance is within constraints, move to the next blade.

6. Repeat this procedure on each blade.

Removing the Blades

Replace the blades if they hit a solid object, or if the blade is out of balance or bent.

1. Place a wrench on the flat of the spindle shaft or hold the blade end using a rag or thickly padded glove.
2. Remove the blade bolt, bushing, and blade from the spindle shaft ([Figure 106](#)).

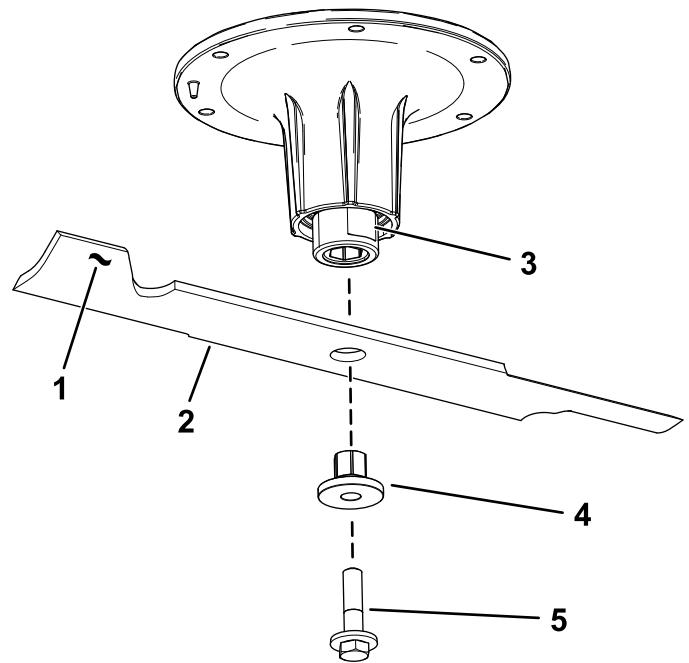

Figure 106

1. Sail area of the blade
2. Blade
3. Flat of the spindle shaft
4. Bushing
5. Blade bolt

Sharpening the Blades

1. Use a file to sharpen the cutting edge at both ends of the blade ([Figure 107](#)).

Note: Maintain the original angle.

Note: The blade retains its balance if the same amount of material is removed from both cutting edges.

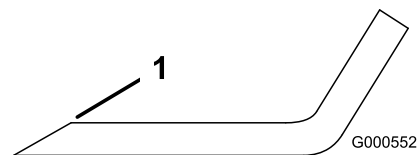

Figure 107

1. Sharpen at original angle.

2. Check the balance of the blade by putting it on a blade balancer ([Figure 108](#)).

Note: If the blade stays in a horizontal position, the blade is balanced and can be used.

Note: If the blade is not balanced, file some metal off the end of the sail area only ([Figure 107](#)).

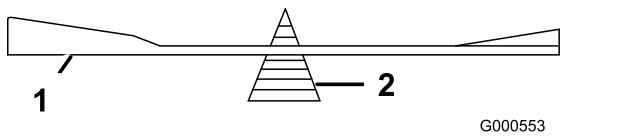

Figure 108

1. Blade
2. Balancer

3. Repeat this procedure until the blade is balanced.

Installing the Blades

1. Install the bushing through the blade with the bushing flange on the bottom (grass) side of the blade ([Figure 109](#)).

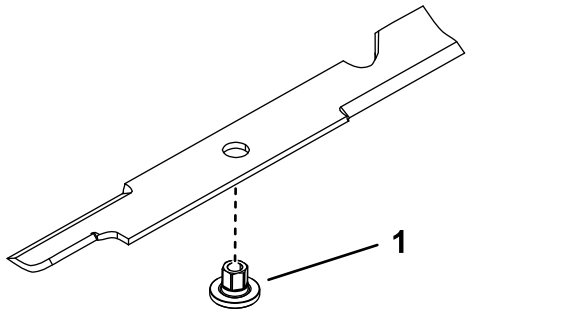

Figure 109

1. Bushing

2. Install the bushing/blade assembly into the spindle shaft ([Figure 110](#)).

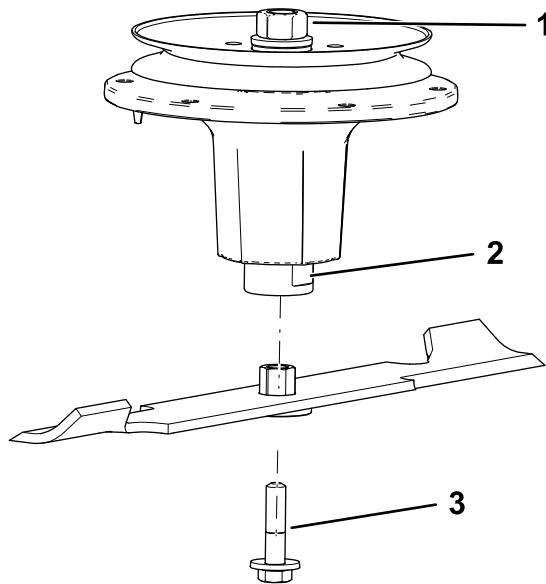

Figure 110

1. Top spindle nut
2. Flat of the spindle shaft
3. Blade bolt

3. Apply copper-based lubricant or grease to the threads of the blade bolt as needed to prevent seizing. Install the blade bolt finger-tight.
4. Place a wrench on the flat of the spindle shaft and torque the blade bolt to 75 to 81 N·m (55 to 60 ft-lb).

Leveling the Mower Deck at 3 Positions

Important: There are only 3 measuring positions needed to level the mower.

Setting Up the Machine

1. Park the machine on a level surface, disengage the blade-control switch, and engage the parking brake.
2. Shut off the engine, remove the key, and wait for all moving parts to stop before leaving the operating position.
3. Check tire pressure of the tires; if needed, adjust to 90 kPa (13 psi).
4. Lower the mower to the 76 mm (3 inches) height-of-cut position.
5. Inspect the 4 chains.

Note: The chains need to have tension.

Note: Adjust the rear chains to the top of the slot, where they are attached to the mower deck.

- If a rear chain is loose, lower (loosen) the front-support arm on the same side; refer to [Adjusting the Front-to-Rear Mower Deck Pitch](#) (page 76).
- If a front chain is loose, raise (tighten) the front-support arm for that chain; refer to [Adjusting the Front-to-Rear Mower Deck Pitch](#) (page 76).

Leveling the Mower Deck Side-to-Side

1. Position the **right** blade side-to-side ([Figure 111](#)).

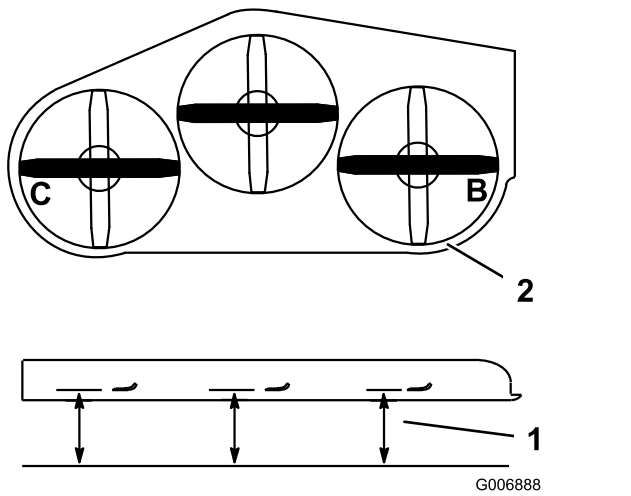

Figure 111

1. Measure here from blade to hard surface
2. Measure at B and C

2. Measure the right blade at the **B** location, from a level surface to the cutting edge of the blade tip (Figure 111).
3. Record this measurement. This measurement needs to be 80 to 83 mm (3-1/8 to 3-1/4 inches).
4. Position the left blade side-to-side (Figure 111).
5. Measure the left blade at the **C** location (Figure 111), from a level surface to the cutting edge of the blade tip.
6. Record this measurement. This measurement needs to be 80 to 83 mm (3-1/8 to 3-1/4 inches).
7. If the measurements at positions **B** or **C** are not correct, loosen the bolt attaching the rear chain to the rear-support arm (Figure 112).

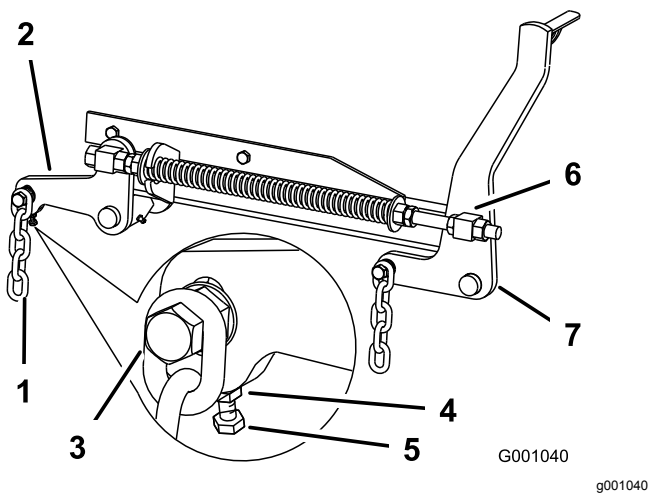

Figure 112

1. Rear chain
2. Rear-support arm
3. Bolt
4. Jam nut
5. Adjustment bolt
6. Front swivel
7. Front-support arm

8. Loosen the jam nut under the rear-support arm and adjust the adjustment bolt to get a measurement of 80 to 83 mm (3-1/8 to 3-1/4 inches); refer to Figure 112.
- Note:** It is recommended that both sides of the mower are adjusted the same distance.
9. Tighten the jam nut under the rear-support arm and tighten the bolt securing the chain to the rear-support arm.
 10. Adjust the opposite side if needed.

Adjusting the Front-to-Rear Mower Deck Pitch

1. Position the **right** blade front-to-rear (Figure 113).

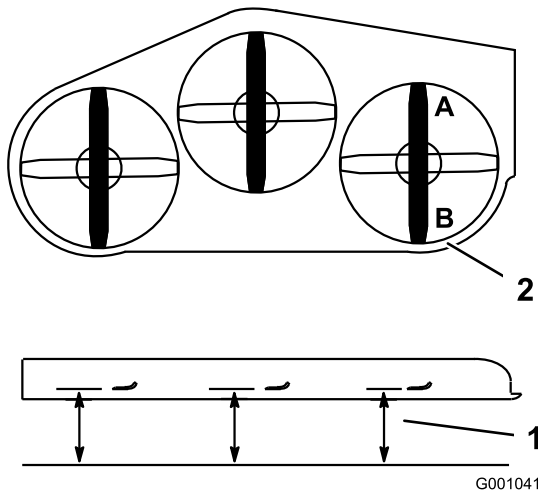

Figure 113

1. Measure here from blade to hard surface
2. Measure at A and B

2. Measure the right blade at the **A** location, from a level surface to the cutting edge of the blade tip (Figure 113).
3. Record this measurement.
4. Measure the right blade at the **B** location, from a level surface to the cutting edge of the blade tip (Figure 113).
5. Record this measurement.
6. The mower blade should be 6 to 10 mm (1/4 to 3/8 inch) lower at position **A** than at position **B** (Figure 113). If it is not correct, proceed to the following steps.

Note: Adjust both of the front swivels the same amount to maintain equal chain tension.

7. Loosen the front swivel jam nuts, at the front of the right and left swivels, approximately 13 mm (1/2 inch) (Figure 112).
8. Adjust the lift nuts on both the left and the right side of the machine to achieve 6 to 10 mm (1/4 to 3/8 inch) lower in front at **A** than in the rear at **B** (Figure 112).
9. Tighten both swivel jam nuts against the front swivel to lock the height.
10. Ensure that there is equal tension on the chains and adjust again if needed.

Adjusting the Compression Spring

1. Raise the mower deck lift lever to the transport position.
2. Check the distance between the 2 large washers, it needs to be 28.2 cm (11-1/8 inches) for 52-inch mower decks, 26.7 cm (10-1/2 inches) for 60-inch mower decks, or 29.2 cm (11-1/2 inches) for 72-inch mower decks (Figure 114).

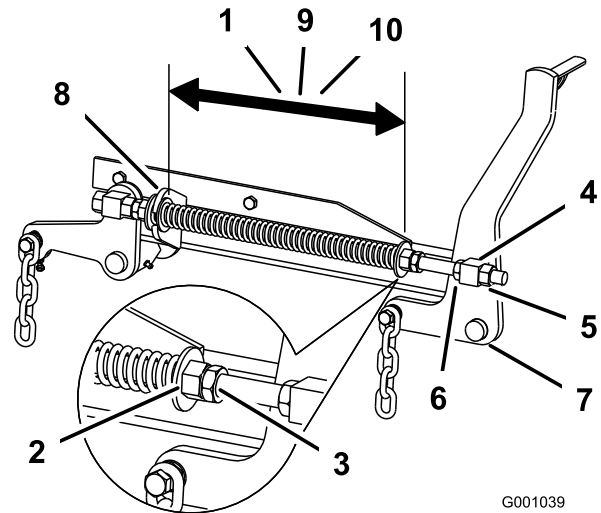

Figure 114

1. 28.2 cm (11-1/8 inches) between the large washers for 52-inch mower decks
2. Front nut
3. Spring-jam nut
4. Front swivel
5. Swivel jam nut
6. Lift nut
7. Front-support arm
8. Large washer
9. 26.7 cm (10-1/2 inches) between the large washers for 60-inch mower decks
10. 29.2 cm (11-1/2 inches) between the large washers for 72-inch mower decks

3. Adjust this distance, by loosening the spring-jam nut and turning the nut in front of each spring (Figure 114).

Note: Turning the nut clockwise shortens the spring; counter-clockwise lengthens the spring.

4. Lock the nut into position by tightening the spring-jam nut (Figure 114).

Replacing the Grass Deflector

Side Discharge Machines Only

⚠ WARNING

An uncovered discharge opening could allow the machine to throw objects toward you or bystanders, resulting in serious injury. Also, contact with the blade could occur.

- Never operate the machine unless you install a cover plate, a mulch plate, or a grass chute and catcher.
- Make sure that the grass deflector is in the down position.

1. Remove the locknut, bolt, spring and spacer holding the deflector to the pivot brackets (Figure 115).
2. Remove the damaged or worn grass deflector.
3. Place the spacer and spring onto the grass deflector. Place the L end of the spring behind the deck edge.

Note: Make sure that the L end of the spring is installed behind the deck edge before installing the bolt as shown in Figure 115

4. Install the bolt and nut.
5. Place the J-hook end of the spring around the grass deflector (Figure 115).

Important: The grass deflector must be able to lower into position. Lift the deflector up to test that it lowers into the full-down position.

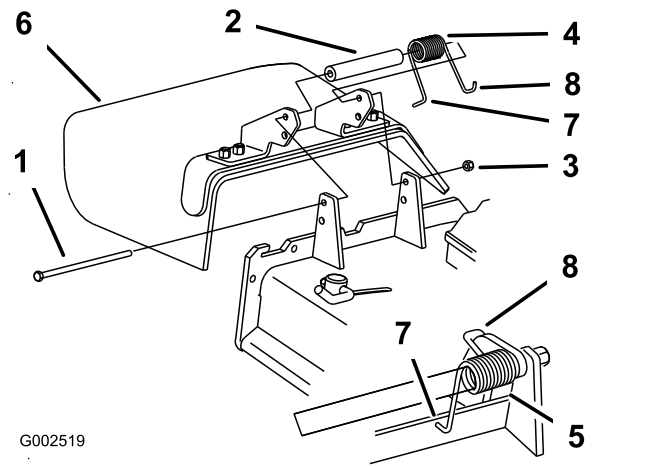

Figure 115

- | | |
|------------|---|
| 1. Bolt | 5. Spring installed |
| 2. Spacer | 6. Grass deflector |
| 3. Locknut | 7. L-end of spring, place behind deck edge before installing bolt |
| 4. Spring | 8. J-hook end of spring |

Cleaning

Cleaning under the Mower Deck

Service Interval: Before each use or daily

1. Park the machine on a level surface, disengage the blade-control switch (PTO), and engage the parking brake.
2. Shut off the engine, remove the key, and wait for all moving parts to stop before leaving the operating position.
3. Raise the mower deck to the TRANSPORT position.

Disposing of Waste

Engine oil, batteries, hydraulic fluid, and engine coolant are pollutants to the environment. Dispose of these according to your state and local regulations.

Storage

Storage Safety

- Shut off the engine, remove the key, wait for all moving parts to stop, and allow the machine to cool before storing it.
- Do not store the machine or fuel near flames or drain the fuel indoors.
- Remove the key and store it in a safe place out of the reach of children.

Cleaning and Storage

1. Disengage the blade-control switch (PTO), engage the parking brake, turn the ignition key to the OFF position, and remove the key.
2. Remove grass clippings, dirt, and grime from the external parts of the entire machine, especially the engine and hydraulic system. Clean dirt and chaff from the outside of the engine cylinder head fins and blower housing.

Important: You can wash the machine with mild detergent and water. Do not pressure wash the machine. Avoid excessive use of water, especially near the control panel, engine, hydraulic pumps, and motors.

3. Check the brake; refer to [Brake Maintenance \(page 61\)](#).
Service the air cleaner; refer to [Servicing the Air Cleaner \(page 46\)](#).
Grease the machine; refer to [Lubrication \(page 42\)](#).
4. Change the crankcase oil; refer to [Servicing the Engine Oil \(page 47\)](#).
Check the tire pressure; refer to [Checking the Tire Pressure \(page 56\)](#).
Change the hydraulic filter; refer to [Changing the Hydraulic Fluid and Filter \(page 68\)](#).
Charge the battery; refer to [Charging the Battery \(page 54\)](#).
Scrape any heavy buildup of grass and dirt from the underside of the mower, then wash the mower with a garden hose.

Note: Run the machine with the blade-control switch (PTO) engaged and the engine at high idle for 2 to 5 minutes after washing.

5. Check the condition of the blades; refer to [Inspecting the Blades \(page 71\)](#).
Prepare the machine for storage when non-use occurs over 30 days. Prepare the machine for storage as follows:

- A. Run the engine to distribute conditioned fuel through the fuel system for 5 minutes.
- B. Shut off the engine, allow it to cool, and drain the fuel tank; refer to [Servicing the Fuel Tank \(page 52\)](#).

Note: Start the engine and run it until it shuts off.

- C. Dispose of fuel properly. Recycle as per local codes.

Important: Do not store stabilizer/conditioned fuel longer than the duration recommended by the fuel-stabilizer manufacturer.

6. Check and tighten all bolts, nuts, and screws. Repair or replace any part that is damaged.
7. Paint all scratched or bare metal surfaces. Paint is available from your Authorized Service Dealer.
8. Store the machine in a clean, dry garage or storage area. Remove the key from the ignition switch and keep it out of reach of children or other unauthorized users. Cover the machine to protect it and keep it clean.

Troubleshooting

Problem	Possible Cause	Corrective Action
The starter does not crank.	<ol style="list-style-type: none"> 1. The blade-control switch is engaged. 2. The parking brake is disengaged. 3. The motion-control levers are not in the NEUTRAL-LOCK position. 4. You are not sitting in the operator's seat. 5. The battery is dead. 6. The electrical connections are corroded or loose. 7. A fuse is blown. 8. A relay or switch is damaged. 	<ol style="list-style-type: none"> 1. Disengage the blade-control switch. 2. Engage the parking brake. 3. Move the motion-control levers outward to the NEUTRAL-LOCK position. 4. Sit on the operator's seat. 5. Charge the battery. 6. Check the electrical connections for good contact. 7. Replace the fuse. 8. Contact an Authorized Service Dealer.
The engine does not start, starts hard, or fails to keep running.	<ol style="list-style-type: none"> 1. The fuel tank is empty. 2. The fuel-shutoff valve is closed. 3. The oil level in the crankcase is low. 4. The throttle is not in the correct position. 5. There is dirt in fuel filter. 6. There is dirt, water, or stale fuel is in the fuel system. 7. The air cleaner is dirty. 8. The seat switch is not functioning properly. 9. The electrical connections are corroded, loose or faulty. 10. The relay or switch is broken. 	<ol style="list-style-type: none"> 1. Fill the fuel tank. 2. Open the fuel-shutoff valve. 3. Add oil to the crankcase. 4. Be sure that the throttle control is midway between the SLOW and FAST positions. 5. Replace the fuel filter. 6. Contact an Authorized Service Dealer. 7. Clean or replace the air-cleaner element. 8. Check the seat switch indicator. Replace the seat if needed. 9. Check the electrical connections for good contact. Clean the connector terminals thoroughly with electrical contact cleaner, apply dielectric grease, and connect. 10. Contact an Authorized Service Dealer.
The engine loses power.	<ol style="list-style-type: none"> 1. The engine load is excessive. 2. The air cleaner is dirty. 3. The oil level in the crankcase is low. 4. The cooling fins and the air passages above the engine are plugged. 5. The vent hole in the fuel cap is plugged. 6. There is dirt in the fuel filter. 7. There is dirt, water, or stale fuel in the fuel system. 	<ol style="list-style-type: none"> 1. Reduce the ground speed. 2. Clean the air-cleaner element. 3. Add oil to the crankcase. 4. Remove the obstruction from the cooling fins and the air passages. 5. Clean or replace the fuel cap. 6. Replace the fuel filter. 7. Contact an Authorized Service Dealer.
The engine overheats.	<ol style="list-style-type: none"> 1. The engine load is excessive. 2. The oil level in the crankcase is low. 3. The cooling fins and air passages under the engine-blower housing are plugged. 4. The air cleaner is dirty. 5. Dirt, water, or stale fuel is in the fuel system. 	<ol style="list-style-type: none"> 1. Reduce the ground speed. 2. Add oil to the crankcase. 3. Remove the obstruction from the cooling fins and air passages. 4. Clean or replace the air-cleaner element. 5. Contact an Authorized Service Dealer
The machine pulls to the left or right (with the motion-control levers fully forward).	<ol style="list-style-type: none"> 1. The tracking needs adjustment 2. The tire pressure in the drive tires is not correct. 	<ol style="list-style-type: none"> 1. Adjust the tracking. 2. Adjust the tire pressure in the drive tires.

Problem	Possible Cause	Corrective Action
The machine does not drive.	<ol style="list-style-type: none"> 1. The bypass valves are not closed tight. 2. The pump belt is worn, loose, or broken. 3. The pump belt is off a pulley. 4. The idler spring is broken or missing. 5. The hydraulic fluid level is low or too hot. 	<ol style="list-style-type: none"> 1. Tighten the bypass valves. 2. Change the belt. 3. Change the belt. 4. Replace the spring. 5. Add hydraulic fluid to the reservoirs or let it cool down.
The machine vibrates abnormally.	<ol style="list-style-type: none"> 1. The cutting blade(s) is/are bent or unbalanced. 2. The blade mounting bolt is loose. 3. The engine mounting bolts are loose. 4. The engine pulley, idler pulley, or blade pulley is loose. 5. The engine pulley is damaged. 6. The blade spindle is bent. 7. The motor mount is loose or worn. 	<ol style="list-style-type: none"> 1. Install new cutting blade(s). 2. Tighten the blade mounting bolt. 3. Tighten the engine mounting bolts. 4. Tighten the appropriate pulley. 5. Contact an Authorized Service Dealer. 6. Contact an Authorized Service Dealer. 7. Contact an Authorized Service Dealer.
The cutting height is uneven.	<ol style="list-style-type: none"> 1. The blade(s) is not sharp. 2. A cutting blade(s) is/are bent. 3. The mower is not level. 4. An anti-scalp roller (if applicable) is not set correctly. 5. The underside of the mower deck is dirty. 6. The tire pressure is incorrect. 7. A blade spindle is bent. 	<ol style="list-style-type: none"> 1. Sharpen the blade(s). 2. Install a new cutting blade(s). 3. Level the mower from side-to-side and front-to-rear. 4. Adjust the anti-scalp wheel height. 5. Clean the underside of the mower deck. 6. Adjust the tire pressure. 7. Contact an Authorized Service Dealer.
The blades do not rotate.	<ol style="list-style-type: none"> 1. The mower deck belt is damaged, worn, loose, or broken. 2. The mower deck belt is off the pulley. 3. The pump drive belt is worn, loose, or broken. 4. The idler spring is broken or missing. 	<ol style="list-style-type: none"> 1. Install a new deck belt. 2. Install the mower belt on the deck pulley and check the idler pulley, idler arm, and spring for correct position and function. 3. Check the belt tension or install a new belt. 4. Replace the spring.

Schematics

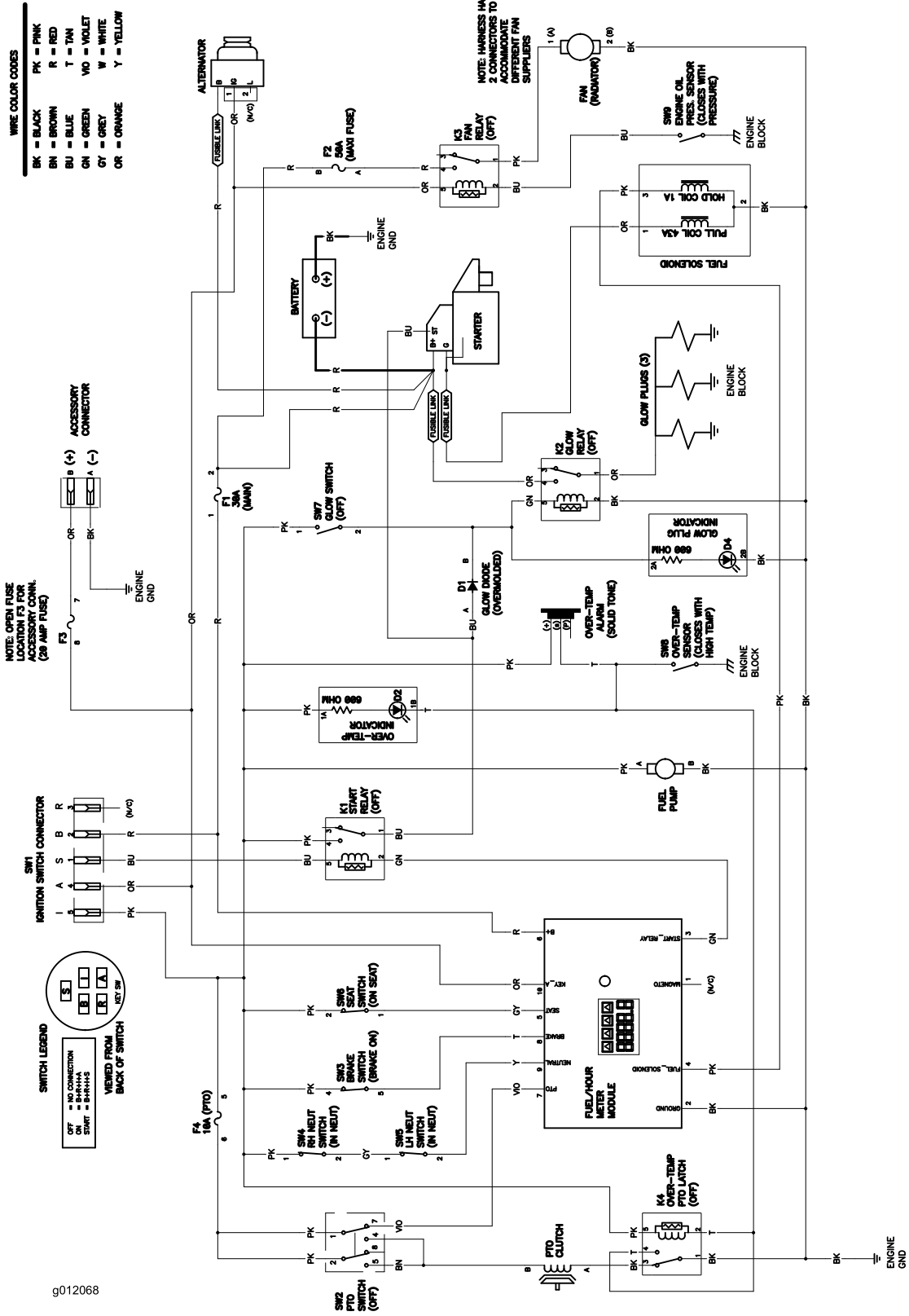

g012068

Wire Diagram (Rev. A)

g012068

EEA/UK Privacy Notice

Toro's Use of Your Personal Information

The Toro Company ("Toro") respects your privacy. When you purchase our products, we may collect certain personal information about you, either directly from you or through your local Toro company or dealer. Toro uses this information to fulfil contractual obligations - such as to register your warranty, process your warranty claim or to contact you in the event of a product recall - and for legitimate business purposes - such as to gauge customer satisfaction, improve our products or provide you with product information which may be of interest. Toro may share your information with our subsidiaries, affiliates, dealers or other business partners in connection these activities. We may also disclose personal information when required by law or in connection with the sale, purchase or merger of a business. We will never sell your personal information to any other company for marketing purposes.

Retention of your Personal Information

Toro will keep your personal information as long as it is relevant for the above purposes and in accordance with legal requirements. For more information about applicable retention periods please contact legal@toro.com.

Toro's Commitment to Security

Your personal information may be processed in the US or another country which may have less strict data protection laws than your country of residence. Whenever we transfer your information outside of your country of residence, we will take legally required steps to ensure that appropriate safeguards are in place to protect your information and to make sure it is treated securely.

Access and Correction

You may have the right to correct or review your personal data, or object to or restrict the processing of your data. To do so, please contact us by email at legal@toro.com. If you have concerns about the way in which Toro has handled your information, we encourage you to raise this directly with us. Please note that European residents have the right to complain to your Data Protection Authority.



Count on it.