



Count on it.

Parts Catalog

Commercial Walk-Behind Mower
Fixed Deck, T-Bar, Gear Drive with 36in
TURBO FORCE® Cutting Unit

Model No. 39674—Serial No. 405670000 and Up



Ordering Replacement Parts

To order replacement parts, please supply the part number, the quantity, and the description of each part desired.

Understanding Reference Numbers

Each identified part in an illustration has a reference number. The reference number for a part also appears in the parts list, along with other information about the part.

This catalog uses two special reference number formats, one to indicate parts in a service assembly and another to indicate the quantity of a given part in an illustration.

Service Assembly Reference Numbers

Parts in service assemblies have reference numbers in the form a:b. The a represents the reference number of the entire service assembly and the b represents a sequential number unique to each part within the service assembly.

For example, a wheel assembly might be identified by reference number 6, the tire by 6:1, the valve by 6:2, and the wheel by 6:3. When you order the assembly identified by reference number 6, you receive all parts identified by reference numbers 6:1, 6:2, and 6:3. However, you may also order any part individually. Reference numbers of this type appear in illustration and in parts lists.

Reference Numbers Indicating Quantity

In an illustration, if a reference number indicates more than one part, the reference number has the form nX y. The n represents the quantity of the part, the X is the multiplication symbol, and the y represents the reference number.

For example, in an illustration, the reference number 2X 37 means that two of the parts identified by reference number 37 are indicated.

Contents

Engine and Exhaust Assembly.....	4
Fuel System Assembly	5
Frame and Transmission Assembly	6
Drive Wheel and Brake Assembly	7
Handle and Control Assembly	9
Wire Harness Assembly	10
Deck Assembly	11
Deck Decal Assembly No. 110-4907.....	12
Deflector Assembly No. 119-6530.....	13
Sheave, Spindle and Blade Assembly	14
Idler Assembly	15
Caster Assembly	16
Attachments and Accessories	17

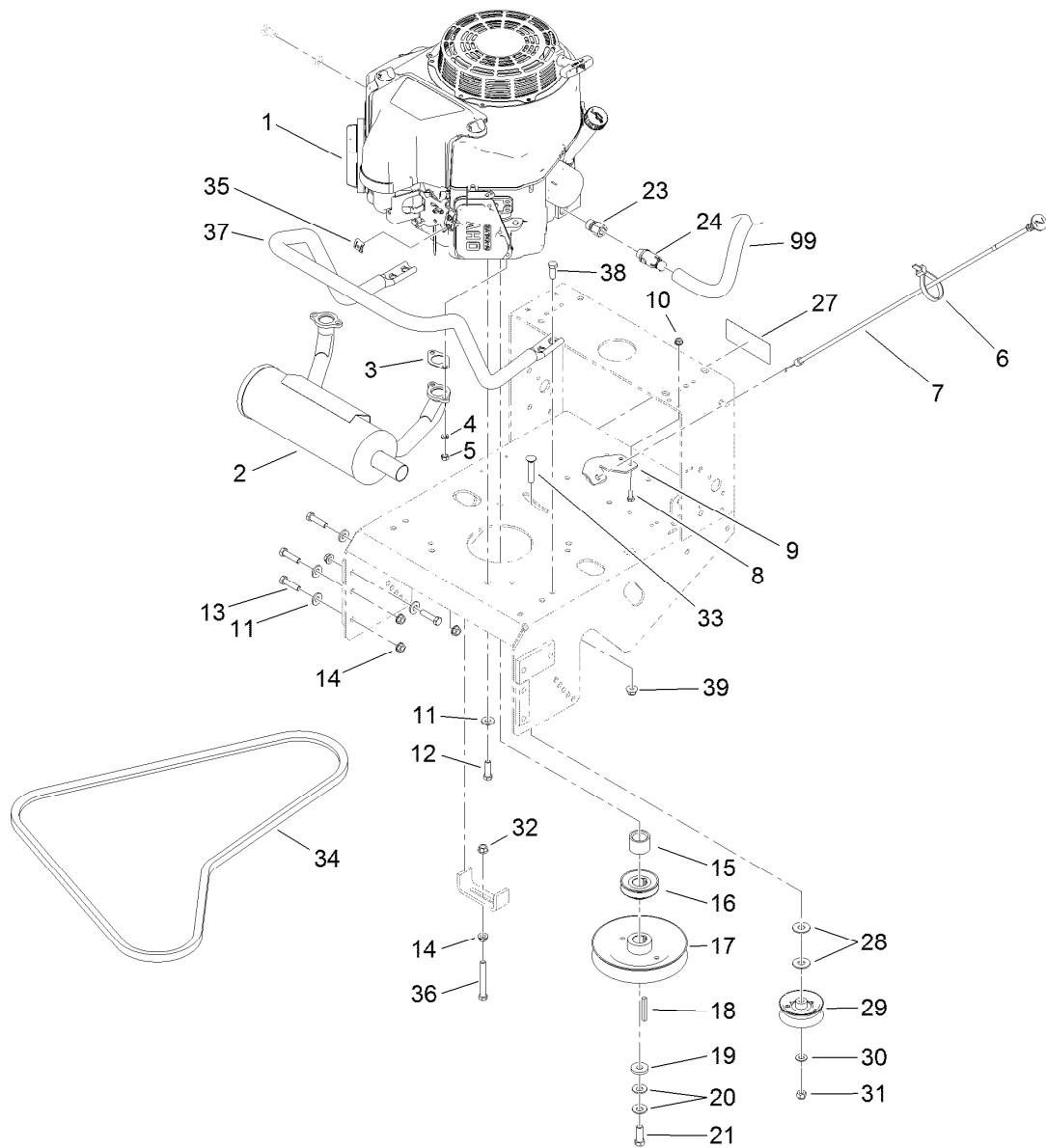

Engine and Exhaust Assembly

Ref.	Part Number	Qty.	Description	Ref.	Part Number	Qty.	Description
1		1	Engine-Kawasaki, Fs481V-As06 ●■	19	1-373034	1	Washer
2	116-3734	1	Muffler-Horizontal, Offset	20	1-603610	2	Washer-Spring
3	1-653313	2	Gasket-Exhaust	21	116-3702	1	Screw-HH
4	114-3550	4	Washer-Lock	23	103-1966	1	Adapter
5	114-3549	4	Nut	24	120-4321	1	Valve-Drain, Oil
6	1-303287	1	Tie-Cable	27	126-1400	1	Decal-Warning, Sulky
7	103-1796	1	Cable-Choke	28	3256-5	2	Washer-Flat
8	321-3	2	Screw-HH	29	130-8362	1	Pulley-Idler, Flat
9	103-1797-01	1	Bracket-Cable, Choke	30	3256-24	1	Washer-Flat
10	32128-33	2	Nut-HF	31	3296-39	1	Nut-Lock, NI
11	98-5975	12	Washer-Belleville	32	32128-21	1	Nut-HF
12	323-7	4	Screw-HH	33	3231-6	1	Screw-CARR
13	323-8	8	Screw-HH	34	110-4886	1	Belt-V
14	3290-357	9	Nut-HHF, Whiz	35	81-1690	1	Clamp-Cable
15	1-633453	1	Spacer-Clutch	36	323-14	1	Screw-HH
16	103-1666	1	Sheave-Transmission	37	116-6278-03	1	Guard-Muffler
17	110-4891	1	Pulley	38	323-6	4	Screw-HH
18	103-4177	1	Key	39	104-8301	4	Nut-HF, NI
				99	103-1964	1	Hose-Drain, Oil

● Not serviced separately

■ Obtain parts from www.kawpowerpc.com

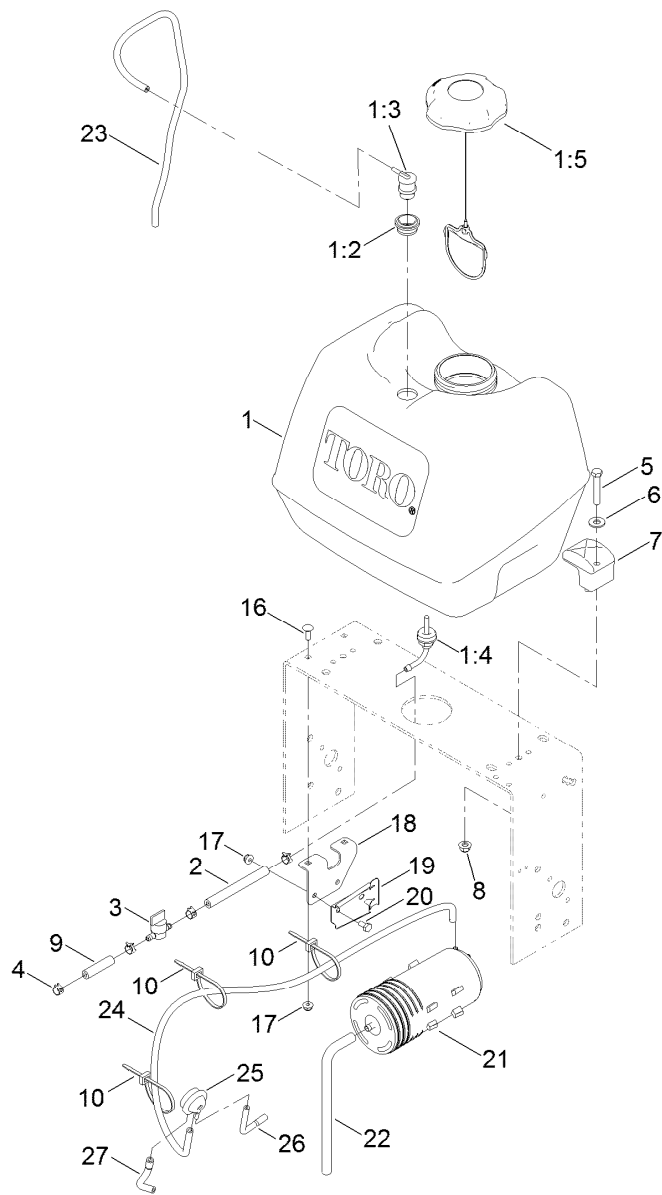

Fuel System Assembly

Ref.	Part Number	Qty.	Description
1	126-1526	1	Fuel Tank ASM
1:2	114-0284	1	Grommet
1:3	119-3547	1	Valve-Vent, Fuel
1:4	103-2605	1	Fitting-Fuel, Bulkhead
1:5	137-4119	1	Cap-Fuel, Ratcheting
2	109-0650	1	Hose-Fuel
3	1-603770	1	Valve-Fuel
4	2412-98	4	Clamp-Hose
5	322-10	2	Screw-HH
6	3256-3	2	Washer-Flat
7	107-4543	2	Clamp
8	104-8300	2	Nut-HF, NI
9	99-9415	1	Hose-Fuel

Ref.	Part Number	Qty.	Description
10	3290-378	3	Tie-Cable
16	3229-1	2	Bolt-CARR
17	104-7201	4	Nut-HF
18	115-4486-01	1	Bracket-Canister, Carbon
19	114-0292	1	Bracket-Canister, Carbon
20	321-2	2	Screw-HH
21	117-1221	1	Canister-Carbon, 800Cc
22	115-0962	1	Hose-Vent, Canister
23	114-0286	1	Hose-Vent
24	116-2231	1	Hose-Vent, Formed
25	116-2232	1	Valve-Control, Vacuum
26	119-8501	1	Hose-Vent, Formed
27	119-8502	1	Hose-Vent, Formed

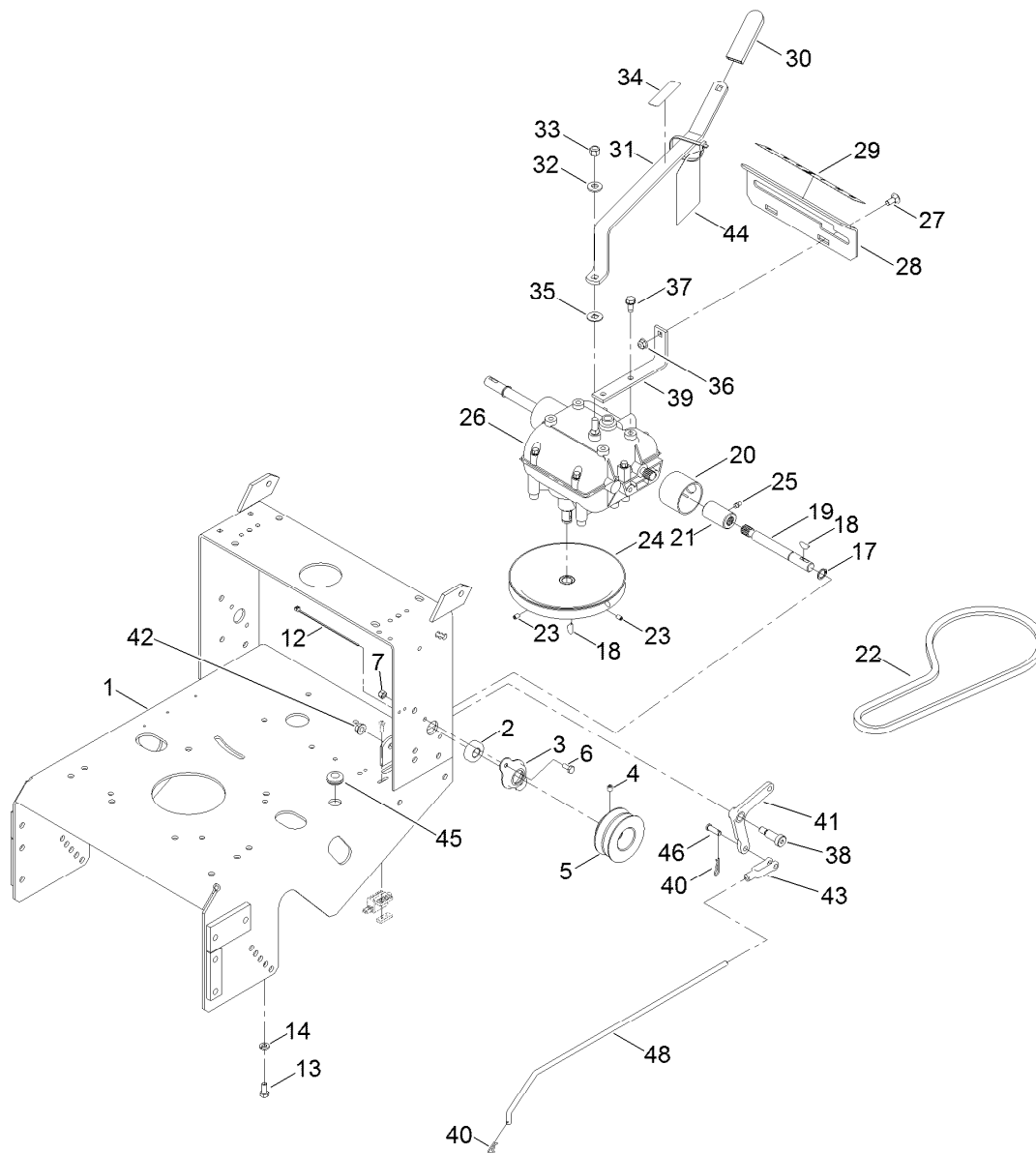

Frame and Transmission Assembly

Ref.	Part Number	Qty.	Description	Ref.	Part Number	Qty.	Description
1	116-6084-01	1	Frame-Gear	28	1-323387-03	1	Plate-Shift
2	1-323252	2	Bearing-Shaft	29	98-3264	1	Decal-Speed, Ground
3	1-323254	2	Flange-Output	30	1-303020	1	Grip-Lever
4	3246-18	2	Setscrew	31	98-3274-03	1	Lever-Shift
5	103-6511	2	Sheave-Transmission	32	98-5975	1	Washer-Belleville
6	321-3	4	Screw-HH	33	3296-6	1	Nut-Lock
7	3296-42	4	Nut-Lock, NI	34	132-4708	1	Decal-Caution, Gearbox
12	1-303287	1	Tie-Cable	35	1-323379	1	Washer
13	322-3	4	Screw-HH	36	104-8300	2	Nut-HF, NI
14	1-805005	4	Washer-Lock	37	32144-11	4	Screw-HWH
17	32151-62	2	Ring-Retaining	38	1-603403	1	Bolt-Shoulder
18	3257-5	3	Key-Woodruff	39	1-323389-03	2	Bracket-Plate, Shift
19	1-323502	2	Shaft-Transmission	40	1-806003	2	Pin-Cotter
20	51-4220	2	Guard-Coupler	41	1-303186	1	Bellcrank
21	1-323680	2	Coupler	42	3290-357	1	Nut-HHF, Whiz
22	1-323630	1	V-Belt	43	1-303105	1	Yoke-Adjustable
23	3245-41	2	Screw-HSH	44	132-4712	1	Hang Tag-Gearbox
24	1-323278	1	Sheave-Transmission	45	1-543296	1	Grommet
25	302-19	2	Fitting-Grease	46	1-808280	1	Pin-Clevis
26	137-4105	1	Transmission-5 Speed	48	1-323303	1	Arm-Assist, Linkage
27	3230-1	2	Bolt-CARR				

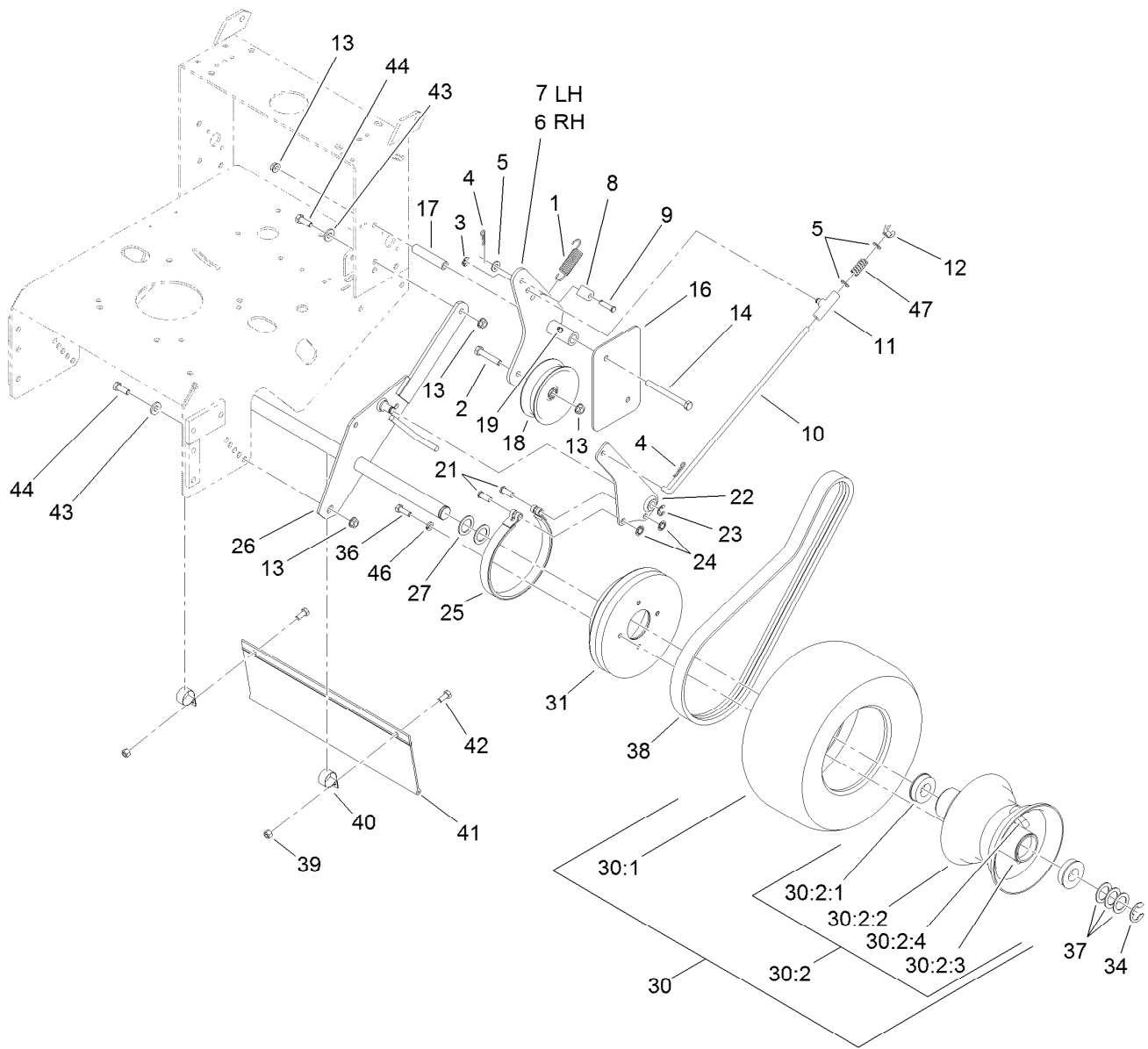

Drive Wheel and Brake Assembly

Ref.	Part Number	Qty.	Description	Ref.	Part Number	Qty.	Description
1	98-3273	2	Spring-Extension	21	1-323307	4	Pin-Clevis
2	323-10	2	Screw-HH	22	1-322209-03	2	Arm-Brake
3	32151-47	2	Ring-Retaining	23	32120-47	2	Ring-Retaining, External
4	1-806003	4	Pin-Cotter	24	1-803051	4	Ring-Retain
5	3256-23	4	Washer-Plain	25	1-323595	2	Band-Brake
6	110-4925-03	1	Arm-Idler, RH	26	1-322212-03	1	Axle
7	110-4926-03	1	Arm-Idler, LH	27	1-543436	2	Washer-Spacer
8	74-0521	2	Fitting-Rod	30	130-8363	2	Wheel And Tire ASM
9	283-6	2	Pin-Clevis	30:1	130-8367	1	Tire
10	1-323296	2	Rod-Brake	30:2	130-4565	1	Wheel And Hub ASM
11	110-5866	2	Swivel-Brake	30:2:1	1-323329	2	Bearing-Flanged
12	1-513959	2	Wingnut-Nylock	30:2:2		1	Rim ASM ●
13	3290-357	10	Nut-HHF, Whiz	30:2:3		1	Fitting-Grease ●
14	323-16	4	Screw-HH	30:2:4		1	Stem-Valve ●
16	98-5131-01	2	Shield-Wheel, Drive	31	109-4359	2	Drum And Sheave ASM
17	1-323694	4	Spacer-Shield	34	1-808519	2	Ring-Snap
18	1-323634	2	Idler-Drive, Wheel	36	322-5	8	Screw-HH
19	302-19	2	Fitting-Grease	37	1-523157	6	Washer-Spacer

● Not serviced separately

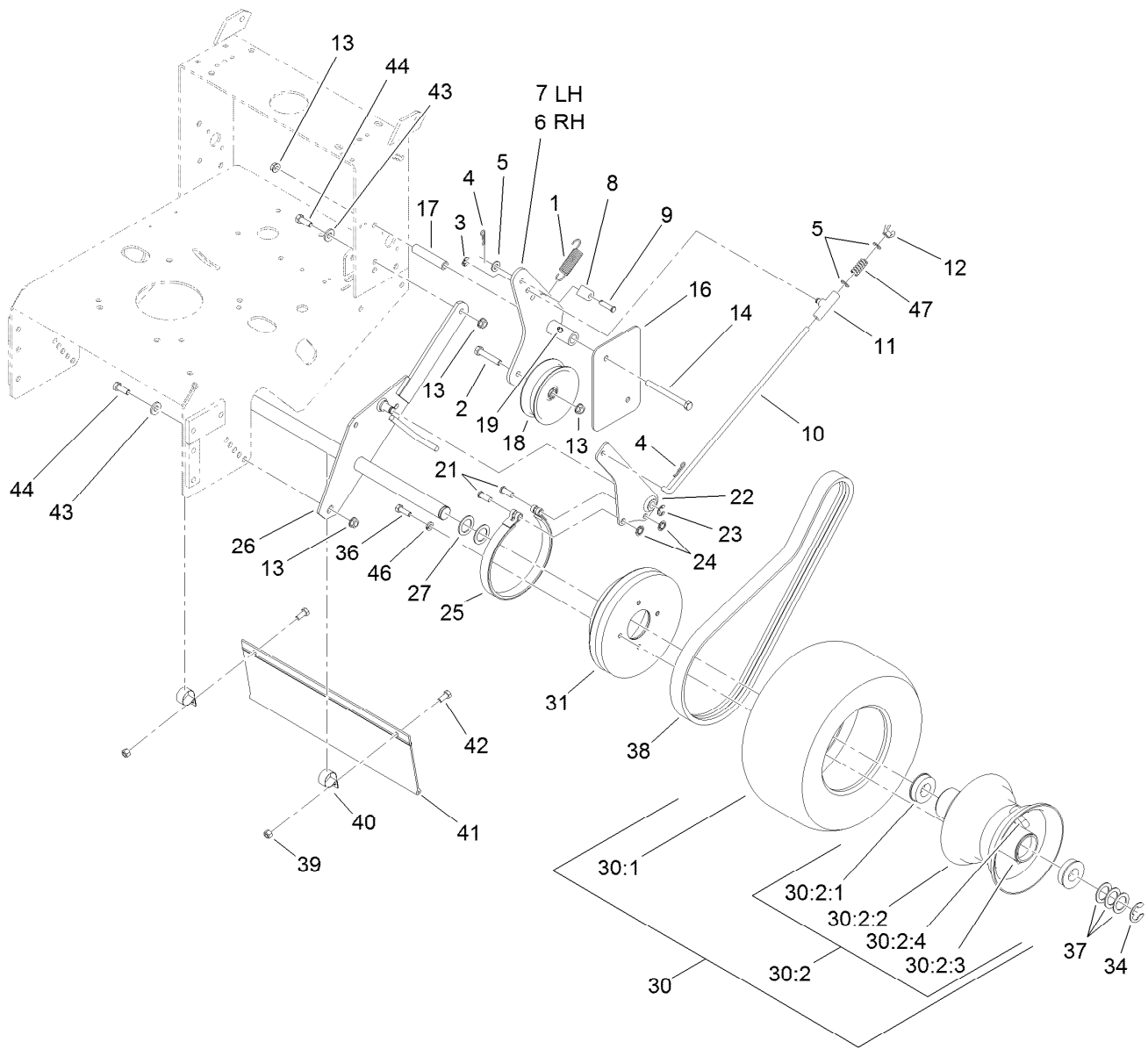

Drive Wheel and Brake Assembly (continued)

Ref.	Part Number	Qty.	Description	Ref.	Part Number	Qty.	Description
38	1-323631	2	V-Belt	43	98-5975	4	Washer-Belleville
39	3296-29	2	Nut-Lock, NI	44	323-6	4	Screw-HH
40	2412-104	2	Clamp-R	46	1-805005	8	Washer-Lock
41	98-3259	1	Shield-Trailing	47	1-323245	2	Spring-Compression
42	322-3	2	Screw-HH				

● Not serviced separately

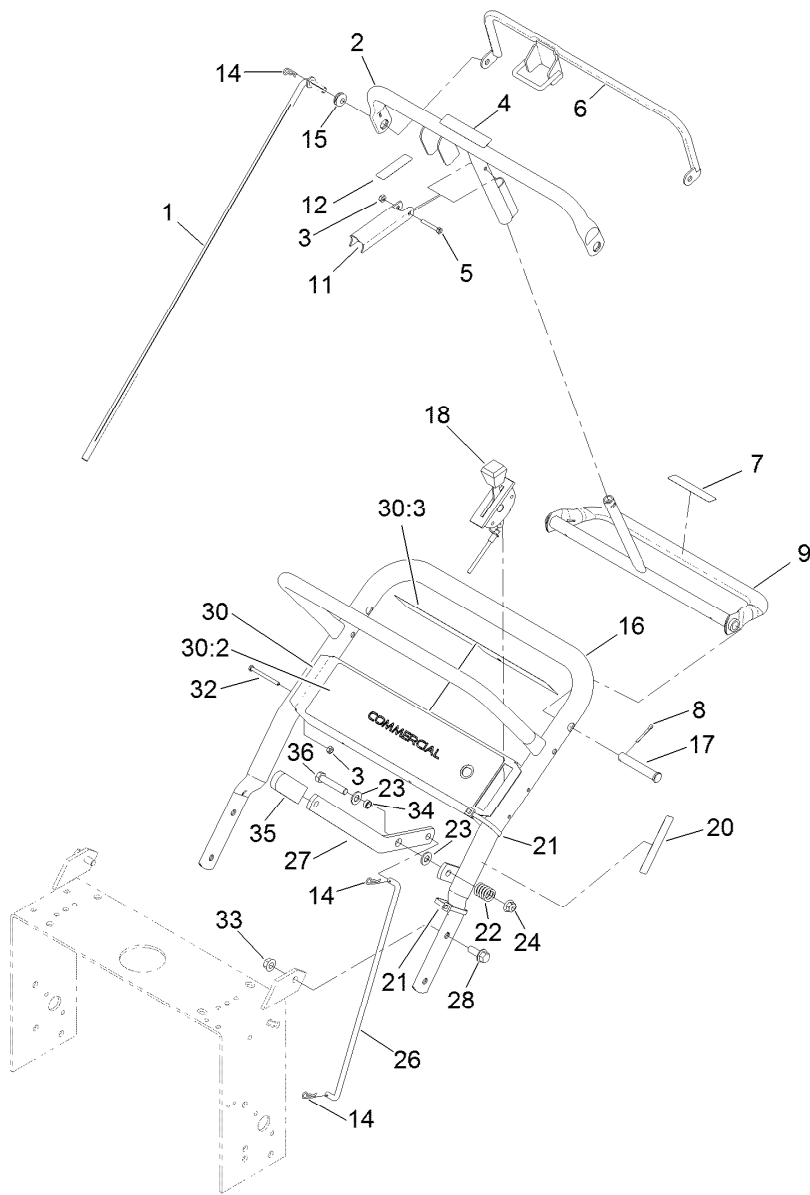

Handle and Control Assembly

Ref.	Part Number	Qty.	Description	Ref.	Part Number	Qty.	Description
1	132-4711	2	Rod-Control	20	95-5537	1	Decal-Engage, Deck
2	95-5522-03	1	Bar-Control	21	1-303335	2	Tie-Plastic
3	3296-2	5	Nut-Lock, NI	22	1-303160	1	Spring-Compression
4	93-7298	1	Decal-Bar, Control	23	3256-24	2	Washer-Flat
5	32105-1	1	Screw-SHH	24	104-8301	1	Nut-HF, NI
6	82-7680-03	1	Bail	26	98-3279	1	Linkage-Drive, Blade
7	93-7299	1	Decal-Reverse	27	98-3287-03	1	Lever-Engagement, Blade
8	3272-11	2	Pin-Cotter	28	3234-11	4	Screw-HHF
9	106-5477-03	1	Pivot-Control	30	140-4296	1	Control Panel ASM
11	98-3261-03	1	Lever-Brake, Parking	30:2	130-8374	1	Decal-Panel, Control
12	93-7442	1	Decal-Lever, Parking	30:3	140-1877	1	Decal - Warning, Control
14	1-806003	3	Pin-Cotter	32	32105-14	4	Screw-SHH
15	237-141	2	Grommet-Rubber	33	32128-21	4	Nut-HF
16	98-3267-03	1	Handle-Upper	34	99-8509	1	Spacer
17	283-55	2	Pin-Clevis	35	1-303020	1	Grip-Lever
18	119-6539	1	Cable-Throttle	36	323-10	1	Screw-HH

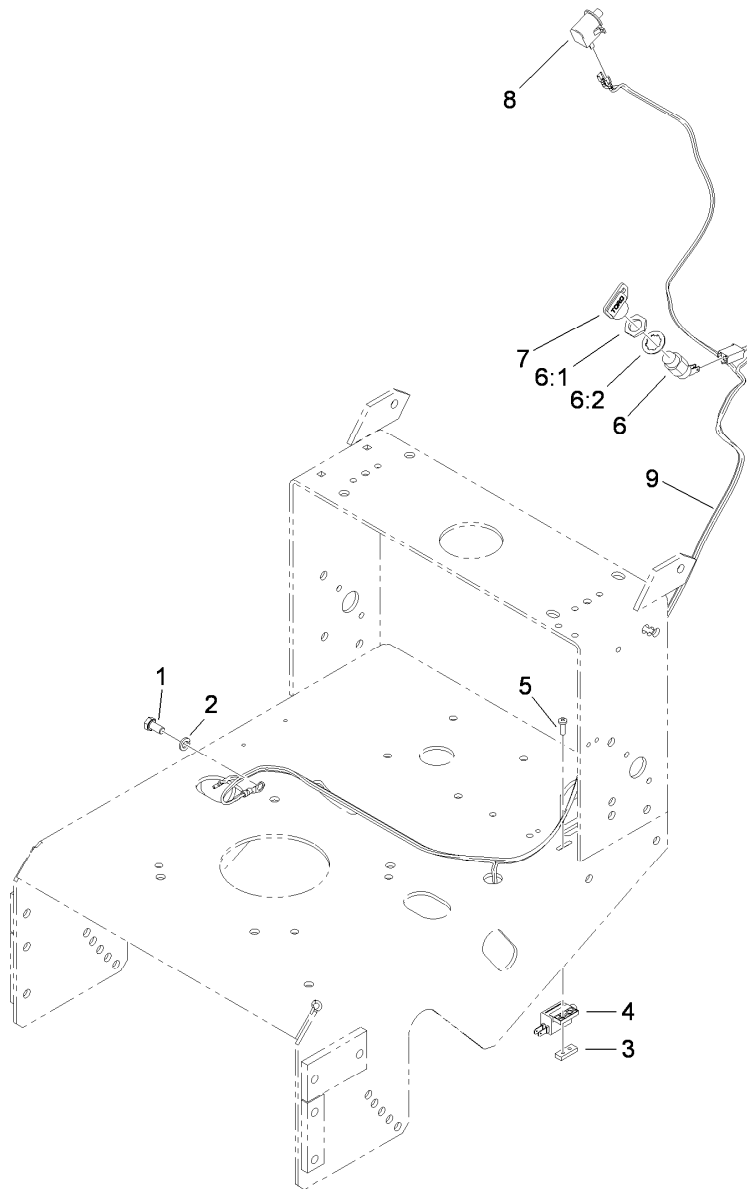

Wire Harness Assembly

<i>Ref.</i>	<i>Part Number</i>	<i>Qty.</i>	<i>Description</i>
1	33114-016	1	Screw-HH
2	3253-4	1	Washer-Lock
3	1-633181	1	Plate-Tapped
4	1-513152	1	Switch-Closed, Normally
5	3290-500	2	Screw-PPH
6	29-5560	1	Switch-On / Off
6:1	218-461	1	Nut-HH
6:2	3254-5	1	Washer-Lock
7	63-8360	1	Key-Ignition
8	740275	1	Switch
9	119-6535	1	Harness-Wire

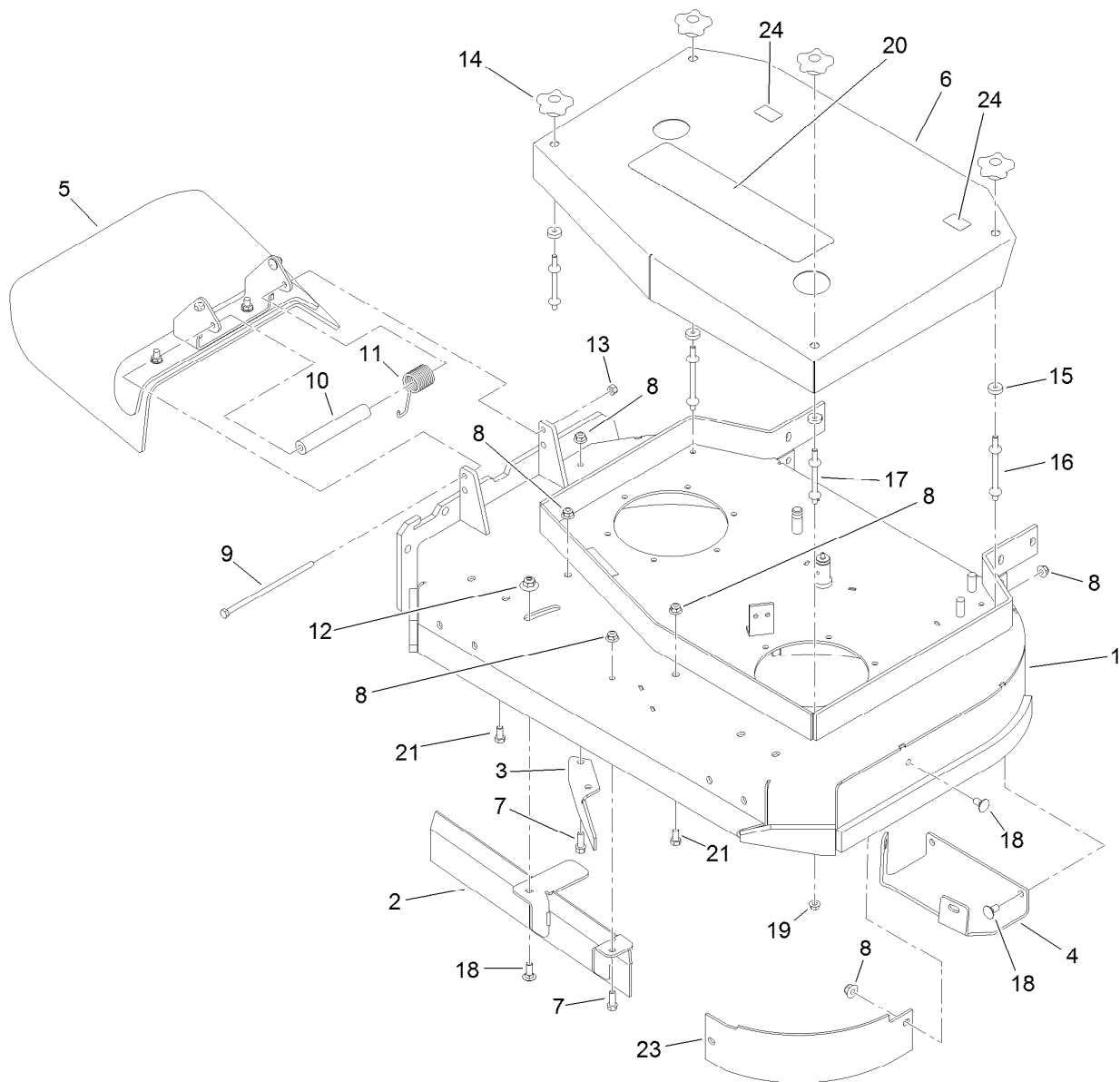

Deck Assembly

<i>Ref.</i>	<i>Part Number</i>	<i>Qty.</i>	<i>Description</i>	<i>Ref.</i>	<i>Part Number</i>	<i>Qty.</i>	<i>Description</i>
1	110-4907	1	Deck ASM	13	3296-47	1	Nut-Lock, NI
2	121-1777-03	1	Baffle	14	106-4161	4	Knob-Handle
3	110-0754-01	1	Baffle-Discharge	15	1-323417	4	Washer
4	110-2037-01	1	Plate-Skid	16	1-303536	2	Stud-Shield, Belt (Long)
5	119-6530	1	Deflector ASM	17	1-303537	2	Stud-Shield, Belt (Short)
6	110-2036-01	1	Cover-Deck	18	3231-2	6	Bolt-CARR
7	92-1624	3	Screw-HWH	19	32128-20	4	Nut-HF
8	104-8301	10	Nut-HF, NI	20	112-9710	1	Decal
9	322-50	1	Screw-HH	21	323-4	2	Screw-HH
10	105-4622	1	Spacer	23	110-6903-03	1	Baffle-Front, LH
11	108-4052	1	Spring-Torsion	24	106-5517	2	Decal-Warning
12	109-6658	1	Nut-Flange, NI				

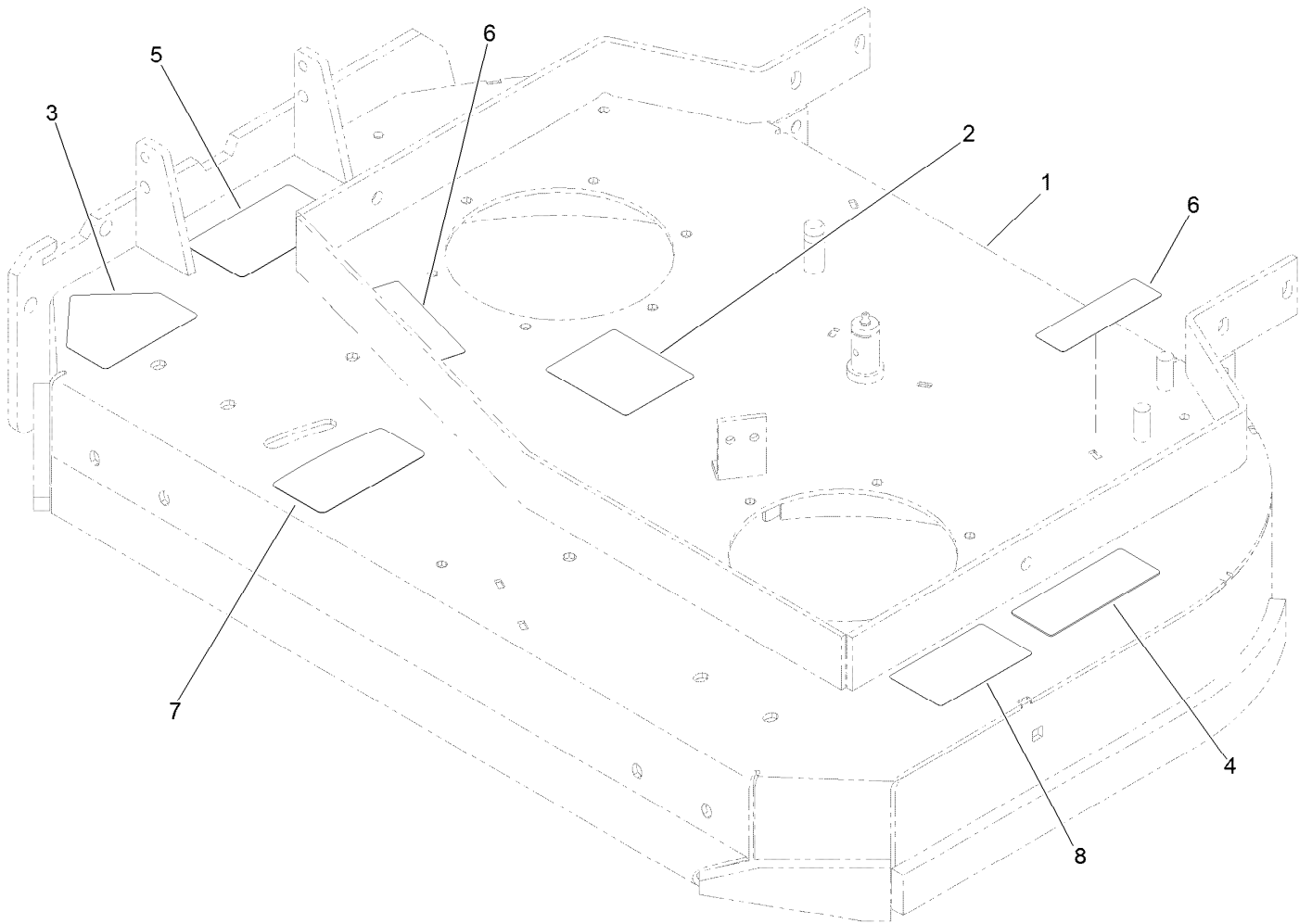

Deck Decal Assembly No. 110-4907

<i>Ref.</i>	<i>Part Number</i>	<i>Qty.</i>	<i>Description</i>
1		1	36 Inch Deck ASM ●
2	98-3296	1	Decal-Routing, Belt
3	112-8760	1	Decal-Danger
4	98-5130	1	Decal-Torque, Bolt
5	121-6049	1	Decal-Danger
6	112-9028	2	Decal-Cover, Missing
7	131-1180	1	Decal-Adjustment, Baffle
8	93-7010	1	Decal-Danger

● Not serviced separately

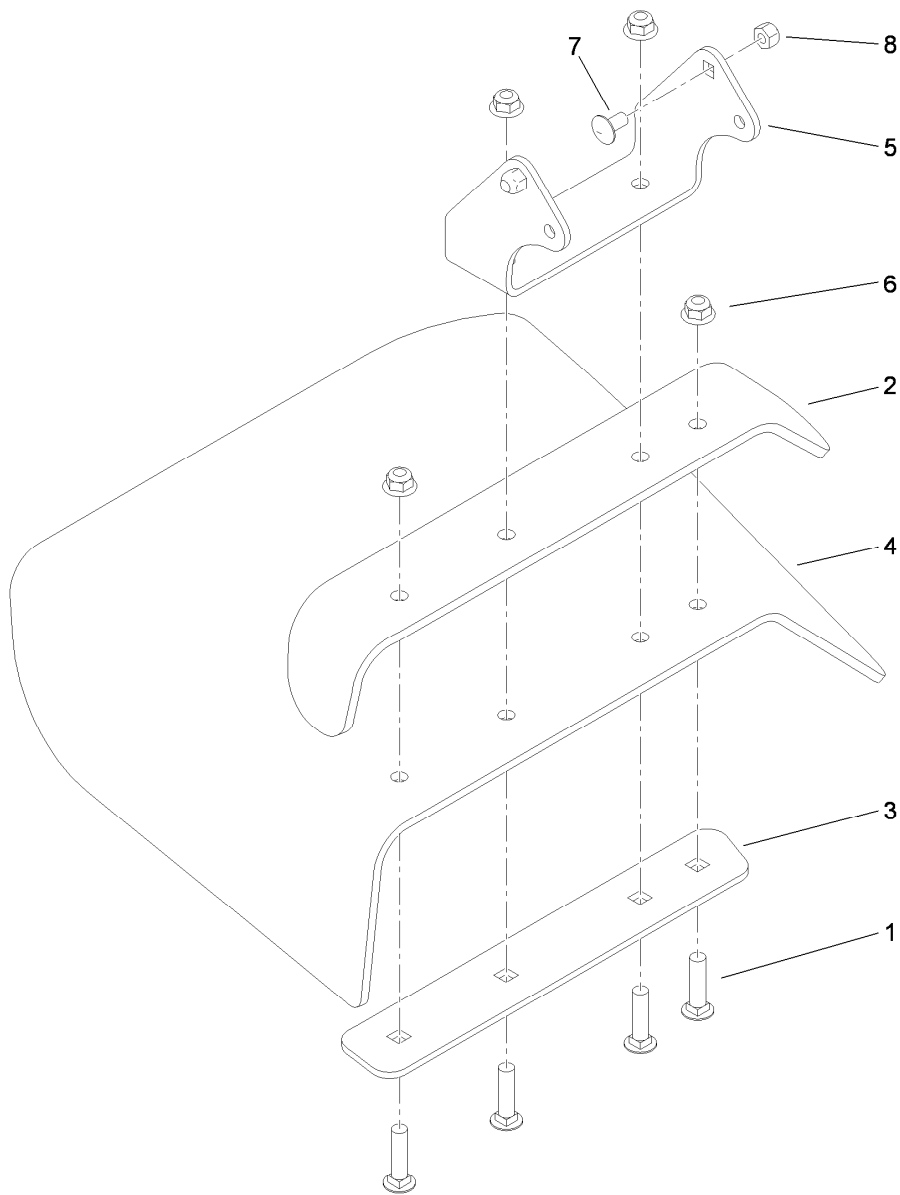

Deflector Assembly No. 119-6530

<i>Ref.</i>	<i>Part Number</i>	<i>Qty.</i>	<i>Description</i>
1	3231-4	4	Screw-CARR
2	110-0792-01	1	Deflector
3	110-0793-03	1	Strap-Discharge
4	110-0791	1	Deflector-Rubber
5	119-6532-01	1	Bracket-Mounting, Deflector
6	104-8301	4	Nut-HF, NI
7	3230-18	2	Screw-CARR
8	3296-29	2	Nut-Lock, NI

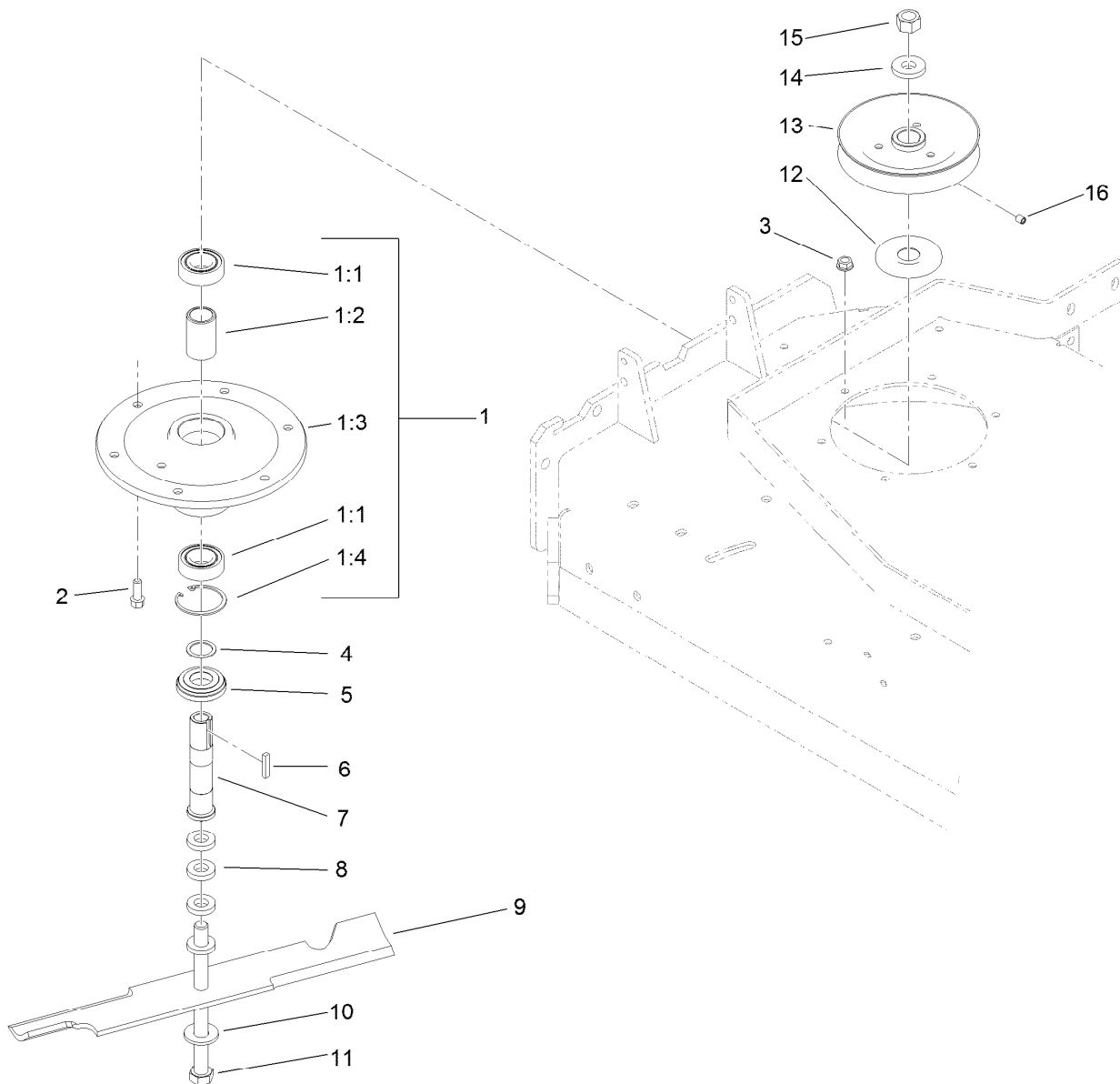

Sheave, Spindle and Blade Assembly

Ref.	Part Number	Qty.	Description	Ref.	Part Number	Qty.	Description
1	108-6697	2	Spindle Housing ASM	7	1-323529	2	Tube-Spindle, Short
1:1	119-7857	2	Bearing-Ball, 1 Inch	8	1-323539	8	Spacer
1:2	110-2116	1	Spacer-Bearing	9	105-7781-03	2	Blade-18In, Hi Flow
1:3	108-6694	1	Housing-Spindle	10	1-513208	2	Washer-Spring
1:4	32120-8	1	Ring-Snap	11	1-800861	2	Screw-Cap, HH
2	92-1624	12	Screw-HWH	12	103-1330	2	Guard-Bearing, Top
3	104-8301	12	Nut-HF, NI	13	1-403183	2	Sheave
4	110-4888	2	Washer-Spacer	14	1-323339	2	Washer-Retainer, Sheave
5	103-2535	2	Spacer-Guard, Bottom	15	3219-6	2	Nut-Hex
6	1-807267	2	Key	16	3246-18	2	Setscrew

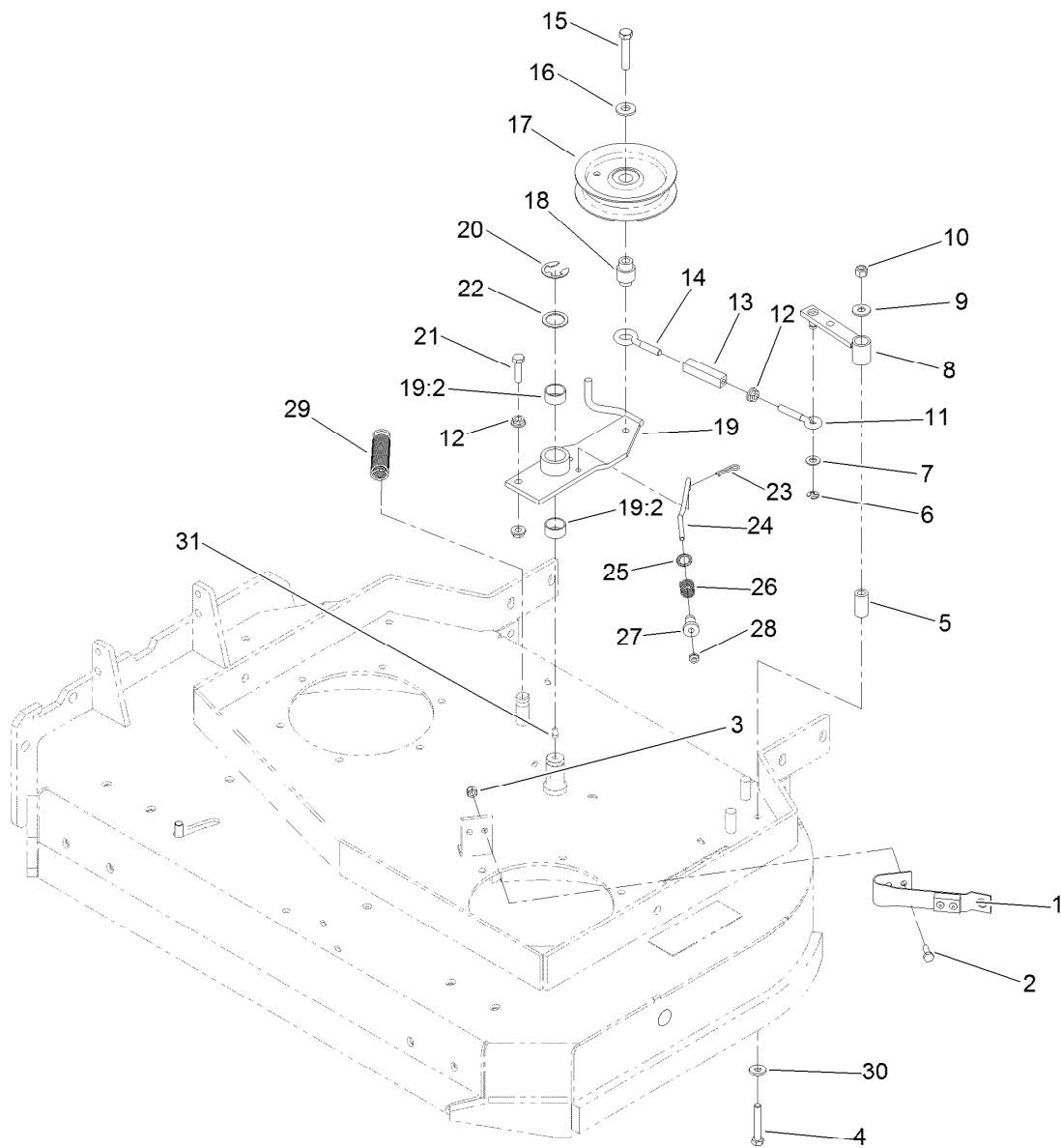

Idler Assembly

Ref.	Part Number	Qty.	Description	Ref.	Part Number	Qty.	Description
1	1-324372	1	Pad And Spring ASM	16	98-5975	1	Washer-Belleville
1:1	1-323709	1	Pad-Brake ●	17	132-4718	1	Pulley-Idler, Flat
1:2	1-323710	1	Spring ●	18	1-303434	1	Bushing-Engagement
1:3	103-0138	2	Rivet-Pop ●	19	103-3600	1	Idler Arm ASM
2	321-4	2	Screw-HH	19:2	1-323729	2	Sleeve-Bearing
3	3296-42	2	Nut-Lock, NI	20	32151-103	1	Ring-Retaining, EXT
4	322-10	1	Screw-HH	21	116-3515	1	Screw-HH, Special
5	1-403179	1	Tube-Pivot	22	1-303352	1	Washer-Spindle
6	32120-35	1	Ring-Retaining, EXT	23	1-806003	1	Pin-Cotter
7	3256-23	1	Washer-Plain	24	1-323715	1	Rod-Brake
8	1-322235	1	Arm-Assist, 32/36	25	1-323748	1	Ring-Push On
9	3256-3	1	Washer-Flat	26	1-323747	1	Spring-Compression
10	3296-29	1	Nut-Lock, NI	27	1-323746	1	Spacer-Flanged
11	1-303238	1	Eyebolt-Thread, RH	28	3296-56	1	Nut-Lock, NI
12	32128-20	3	Nut-HF	29	1-323071	1	Spring-Extension
13	1-303236	1	Body-Turnbuckle	30	1-303334	1	Washer-Spring
14	1-303348	1	Eyebolt-Thread, LH	31	302-40	1	Fitting-Grease, 90 DEG
15	702809	1	Screw-HH				

● Not illustrated

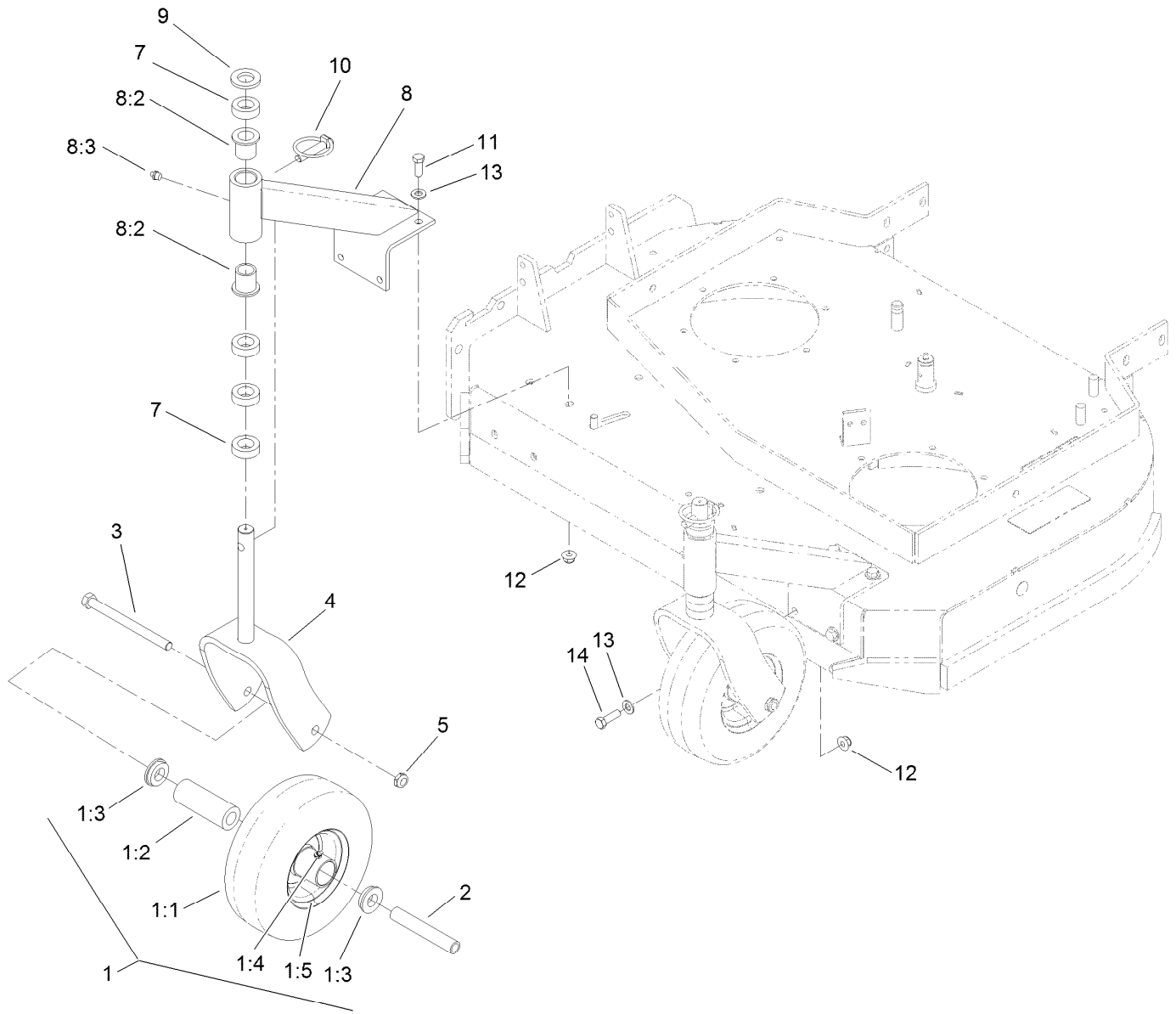

Caster Assembly

Ref.	Part Number	Qty.	Description
1	130-4557	2	Wheel And Tire ASM
1:1		1	Tire ●
1:2	1-513809	1	Bearing
1:3	1-513810	2	Bushing
1:4	302-61	1	Fitting-Grease
1:5		1	Wheel ●
2	1-513547	2	Spacer
3	325-20	2	Screw-HH
4	116-7942-01	2	Fork-Caster
5	3296-45	2	Nut-Hex

Ref.	Part Number	Qty.	Description
7	1-303314	8	Spacer-Caster
8	110-2130	2	Support ASM
8:2	1-303514	2	Bearing-Flanged
8:3	302-52	1	Fitting-Grease
9	1-513338	2	Washer-Flat
10	1-809020	2	Pin
11	323-6	7	Screw-HH
12	104-8301	8	Nut-HF, NI
13	3256-24	8	Washer-Flat
14	323-7	1	Screw-HH

● Not serviced separately

Attachments and Accessories

For 39674 Commercial Walk-Behind Mower Fixed Deck, T-Bar, Gear Drive with 36in TURBO FORCE Cutting Unit

Product Name	Model/Part
Blade-Recycler, 18in.....	105-7779-03
Blade-Med Flow, 18in	105-7794-03
Blade-Low Flow, 18in.....	105-7795-03
Blade-Atomic, 18in	105-7796-03
36in Bagger Enhancement Kit	110-2026
Soft Bag (3 Bushel).....	30104
Sulky.....	30109
Spark Plug	92-2153
Weight Kit	110-2085
Oil Filter	119-5852
36in Recycler Kit.....	110-2080
Blade-Recycler, 18in (6 Pack).....	110-0408
Air Filter Element	120-7447
Blade-Lo Flow, 18in (6 Pack)	110-0406
Oil-30/10W-30 Synthetic (Quart).....	138-6053
Blade-Med Flow, 18in (6 Pack)	110-0409
Blade-Hi Flow, 18in (6 Pack).....	108-1117
Blade-Atomic, 18in (6 Pack)	108-1118
Operator-Controlled Discharge Chute Kit	115-4190
Toro 4-Cycle SAE 30 Oil (32oz Bottle)	38903

Notes:

Notes:



Count on it.