



Count on it.

Operator's Manual

**Commercial Walk-Behind Mower
Fixed Deck, T-Bar, Gear Drive with 32in or
36in Cutting Unit**

Model No. 30672—Serial No. 405670000 and Up

Model No. 39674—Serial No. 405670000 and Up

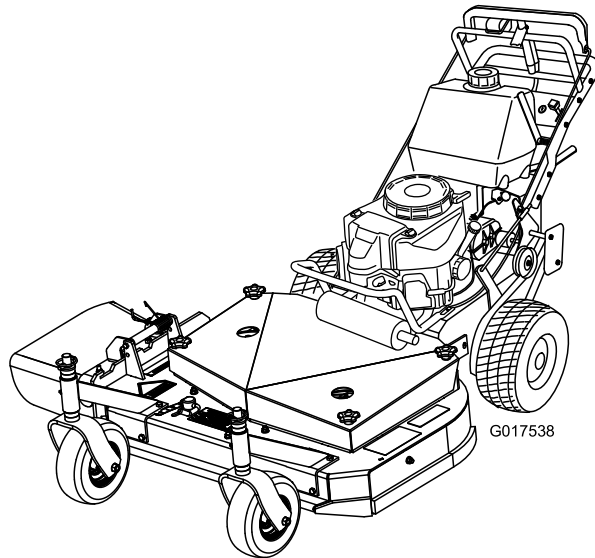

G017538



It is a violation of California Public Resource Code Section 4442 or 4443 to use or operate the engine on any forest-covered, brush-covered, or grass-covered land unless the engine is equipped with a spark arrester, as defined in Section 4442, maintained in effective working order or the engine is constructed, equipped, and maintained for the prevention of fire.

The enclosed engine owner's manual is supplied for information regarding the US Environmental Protection Agency (EPA) and the California Emission Control Regulation of emission systems, maintenance, and warranty. Replacements may be ordered through the engine manufacturer.

⚠ WARNING

**CALIFORNIA
Proposition 65 Warning**

The engine exhaust from this product contains chemicals known to the State of California to cause cancer, birth defects, or other reproductive harm.

Use of this product may cause exposure to chemicals known to the State of California to cause cancer, birth defects, or other reproductive harm.

Introduction

This rotary-blade lawn mower is intended to be used by residential homeowners or professional, hired operators. It is designed primarily for cutting grass on well-maintained lawns on residential or commercial properties. Using this product for purposes other than its intended use could prove dangerous to you and bystanders.

Read this information carefully to learn how to operate and maintain your product properly and to avoid injury and product damage. You are responsible for operating the product properly and safely.

Visit www.Toro.com for more information, including safety tips, training materials, accessory information, help finding a dealer, or to register your product.

Whenever you need service, genuine Toro parts, or additional information, contact an Authorized Service Dealer or Toro Customer Service and have the model and serial numbers of your product ready. [Figure 1](#) identifies the location of the model and serial numbers on the product. Write the numbers in the space provided.

Important: With your mobile device, you can scan the QR code on the serial number decal (if equipped) to access warranty, parts, and other product information.

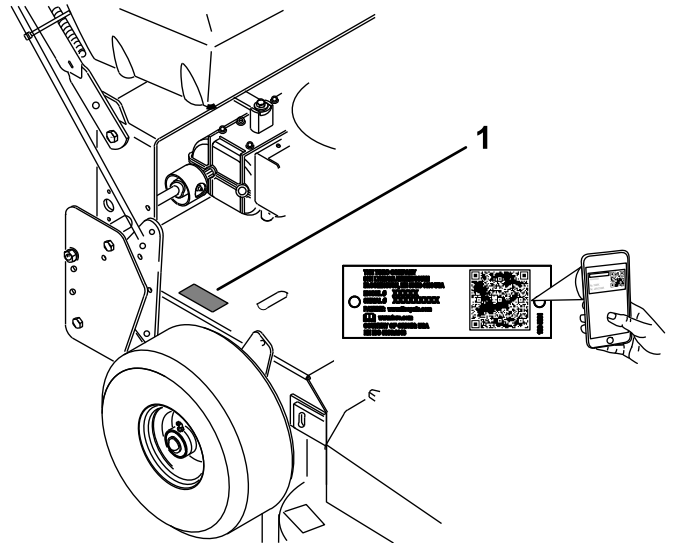

Figure 1

g273246

1. Model and serial number location

Model No. _____
Serial No. _____

This manual identifies potential hazards and has safety messages identified by the safety-alert symbol ([Figure 2](#)), which signals a hazard that may cause serious injury or death if you do not follow the recommended precautions.



Figure 2

Safety-alert symbol

g000502

This manual uses 2 words to highlight information. **Important** calls attention to special mechanical information and **Note** emphasizes general information worthy of special attention.

Contents

Safety	4	Replacing the Traction-Drive Belt.....	34
General Safety.....	4	Replacing the Drive Belt	34
Safety and Instructional Decals	4	Replacing the Mower Belt	35
Product Overview	9	Adjusting the Mower Belt Tension	35
Controls	9	Adjusting the PTO-Engagement	
Specifications	10	Linkage	36
Attachments/Accessories	10	Adjusting the PTO-Safety Switch	37
Before Operation	11	Mower Deck Maintenance.....	38
Before Operation Safety	11	Blade Safety	38
Adding Fuel	11	Servicing the Cutting Blades	38
Performing Daily Maintenance.....	12	Adjusting the Blade Brake.....	40
Using the Safety-Interlock System	12	Replacing the Grass Deflector	40
During Operation	12	Cleaning	41
During Operation Safety	12	Cleaning under the Mower	41
Operating the Parking Brake.....	14	Disposing of Waste	41
Starting the Engine	14	Storage	42
Shutting Off the Engine.....	15	Cleaning and Storing the Machine	42
Operating the Blade-Control Lever		Troubleshooting	43
(PTO).....	15	Schematics	45
Driving the Machine	16		
Using the Lower Control Bar	16		
Stopping the Machine.....	17		
Adjusting the Flow Baffle	17		
Positioning the Flow Baffle.....	18		
Side Discharging or Mulching Grass	19		
Adjusting the Height of Cut	19		
Adjusting the Control Rods	21		
Height-of-Cut Chart	22		
After Operation	23		
After Operation Safety	23		
Hauling the Machine	23		
Maintenance	24		
Maintenance Safety.....	24		
Recommended Maintenance Schedule(s)	24		
Lubrication	25		
Greasing the Machine.....	25		
Lubricating the Caster and Wheel			
Bearings.....	25		
Greasing the Transmission Couplers.....	26		
Greasing the Mower Belt Idler	26		
Engine Maintenance	26		
Engine Safety	26		
Servicing the Air Cleaner	26		
Servicing the Engine Oil.....	27		
Servicing the Spark Plugs.....	29		
Fuel System Maintenance	30		
Servicing the Fuel System	30		
Drive System Maintenance	31		
Checking the Tire Pressure.....	31		
Cooling System Maintenance	32		
Cleaning the Air-Intake Screen	32		
Cleaning the Cooling System.....	32		
Brake Maintenance	33		
Servicing the Parking Brake.....	33		
Belt Maintenance	34		
Inspecting the Belts	34		

Safety

This machine has been designed in accordance with ANSI B71.4-2017.

General Safety

This product is capable of amputating hands and feet and of throwing objects. Always follow all safety instructions to avoid serious personal injury.

- Read, understand, and follow the instructions and warnings in this *Operator's Manual* and on the machine and attachments before starting the engine.
- Do not put your hands or feet near moving parts of or under the machine. Keep clear of any discharge opening.
- Do not operate the machine without all guards and other safety protective devices in place and functioning properly on the machine.

- Keep bystanders and children out of the operating area. Do not allow children to operate the machine. Allow only people who are responsible, trained, familiar with the instructions, and physically capable to operate the machine.
- Stop the machine, shut off the engine, remove the ignition key (if equipped), and wait for all moving parts to stop before servicing, fueling, or unclogging the machine.

Improperly using or maintaining this machine can result in injury. To reduce the potential for injury, comply with these safety instructions and always pay attention to the safety-alert symbol , which means Caution, Warning, or Danger—personal safety instruction. Failure to comply with these instructions may result in personal injury or death.

Safety and Instructional Decals



Safety decals and instructions are easily visible to the operator and are located near any area of potential danger. Replace any decal that is damaged or missing.

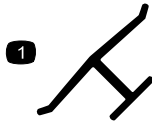

decaloemmarkt

Manufacturer's Mark

1. This mark indicates that the blade is identified as a part from the original machine manufacturer.

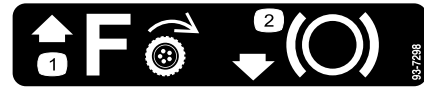

decal93-7298

93-7298

1. Traction drive—Forward
2. Pull to brake.



decal93-7299

93-7299

1. Traction drive—Reverse



decal93-7010

93-7010

1. Thrown object hazard—keep bystanders away.
2. Thrown object hazard, mower—keep the deflector in place.
3. Cutting/dismemberment hazard of hand or foot, mower blade—stay away from moving parts.



93-7442

1. Parking brake

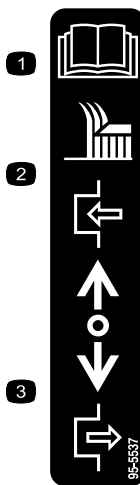

95-5537

1. Read the *Operator's Manual* for instructions on operating the cutting blade.
2. Push forward to engage.
3. Pull back to disengage.

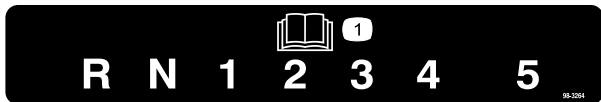

98-3264

1. Read the *Operator's Manual*.

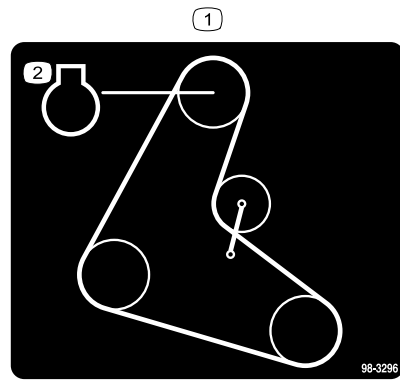

98-3296

1. Belt routing
2. Engine

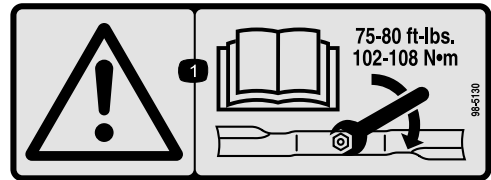

98-5130

1. Warning—read the *Operator's Manual* for instructions on torquing the blade bolt/nut to 102 to 106 N·m (75 to 80 ft-lb).

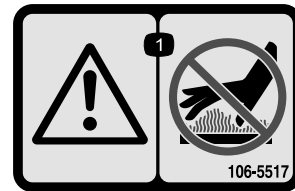

106-5517

1. Warning—do not touch the hot surface.

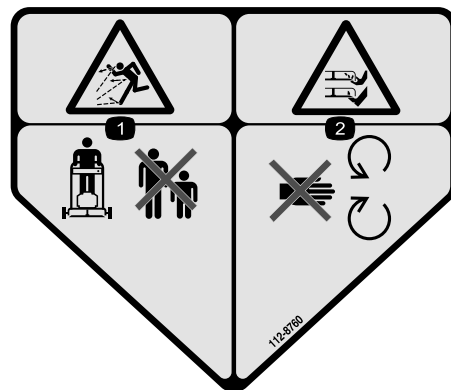

112-8760

1. Thrown object hazard—keep bystanders away.
2. Cutting/dismemberment hazard of hand or foot, mower blade—stay away from moving parts.

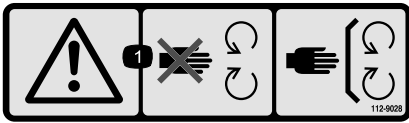

112-9028

decal112-9028

1. Warning—stay away from moving parts; keep all guards and shields in place.

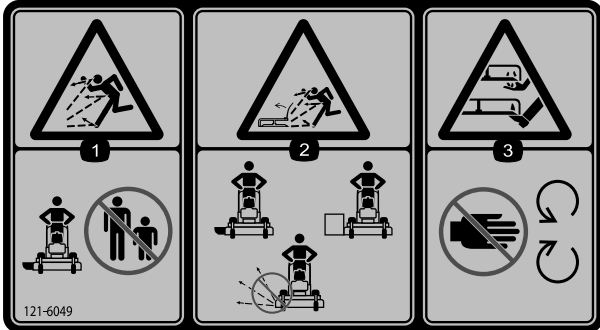

121-6049

decal121-6049

1. Thrown object hazard—keep bystanders away.
2. Thrown object hazard, mower—do not operate the mower with guards or shields removed.
3. Cutting/dismemberment hazard of hand or foot, mower blade—stay away from moving parts.

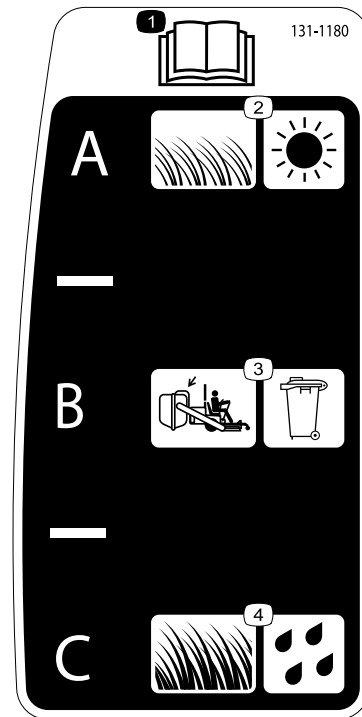

131-1180

decal131-1180

1. Read the *Operator's Manual*.
2. Short, light grass; dry conditions
3. Bagging setting
4. Tall, dense grass; wet conditions



132-4708

decal132-4708

1. Attention—do not adjust the shift lever while moving.
2. Stop moving before adjusting the shift lever.

⚠ WARNING: Cancer and Reproductive Harm - www.P65Warnings.ca.gov.
 For more information, please visit www.tcoCAProp65.com
CALIFORNIA SPARK ARRESTER WARNING
 Operation of this equipment may create sparks that can start fires around dry vegetation. A spark arrester may be required. The operator should contact local fire agencies for laws or regulations relating to fire prevention requirements.

133-8062

133-8062

decal133-8062



130-8374

decal130-8374

1. Fast
2. Slow
3. Engine—stop
4. Engine—slow

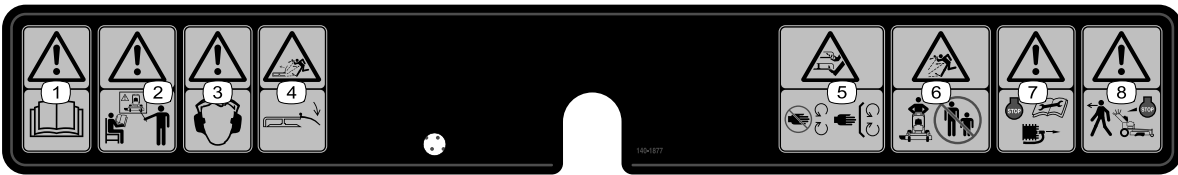

decal140-1877

140-1877

1. Warning—read the *Operator's Manual*.
 2. Warning—all operators should be trained before operating the machine.
 3. Warning—wear hearing protection.
 4. Thrown object hazard, mower—keep the deflector lowered.
 5. Cutting/dismemberment hazard of hand or foot, mower blade—stay away from moving parts; keep all guards and shields in place.
 6. Thrown object hazard—keep bystanders away.
 7. Warning—shut off the engine and disconnect the spark plug before performing maintenance.
 8. Warning—shut off the engine before leaving the machine.
-

Product Overview

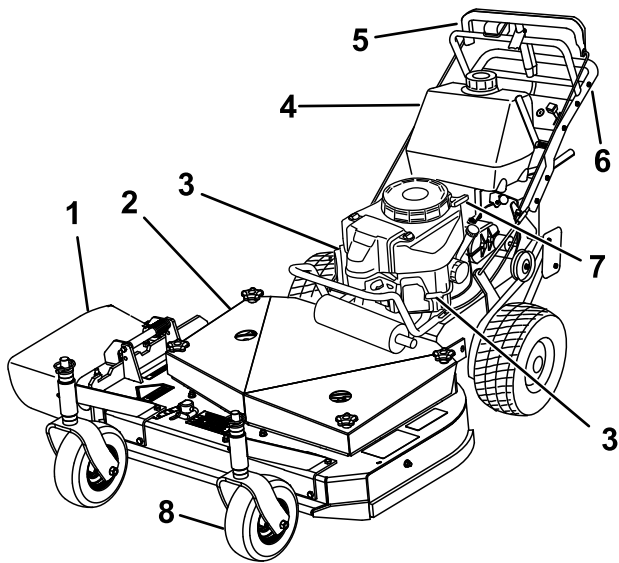

Figure 3

g306582

- | | |
|-------------------|------------------------|
| 1. Side discharge | 5. T-bar control |
| 2. Mower deck | 6. Handle |
| 3. Spark plug | 7. Recoil-start handle |
| 4. Fuel tank | 8. Front caster wheel |

Controls

Become familiar with all the controls before you start the engine and operate the machine.

Control Panel

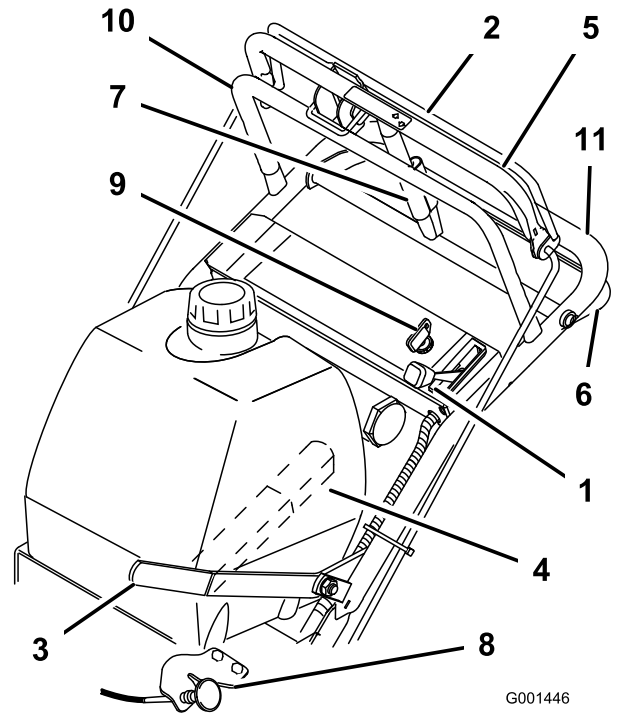

Figure 4

G001446

g001446

- | | |
|--|------------------------|
| 1. Throttle control | 7. Parking-brake lever |
| 2. Blade-control bail | 8. Choke |
| 3. Blade-control lever (power takeoff) | 9. Key switch |
| 4. Gear-shift lever | 10. Upper handle |
| 5. Upper control bar | 11. Lower handle |
| 6. Lower control bar | |

Throttle Control

The throttle controls the engine speed, and it has a continuous-variable setting from the SLOW to FAST position (Figure 4).

Gear-Shift Lever

The gear-shift lever allows you to shift to 5 FORWARD positions, NEUTRAL position, and REVERSE position (Figure 4).

Note: It has an in-line shift pattern.

Important: Do not shift while the machine is moving, as you may damage the transmission.

Blade-Control Lever (Power Takeoff)

Use the blade-control lever in conjunction with the blade-control bail to engage and disengage power to the mower blades (Figure 4).

Recoil-Start Handle

Pull the recoil-start handle to start the engine (Figure 3).

Fuel-Shutoff Valve

Close the fuel-shutoff valve when transporting or storing the machine.

Key Switch

The key switch, used in conjunction with the recoil starter to start and shut off the engine, has 2 positions: RUN and OFF (Figure 4).

Choke

Use the choke to start a cold engine.

Blade-Control Bail

The bail is used in conjunction with the PTO to engage the clutch to drive the mower blades. Release the blade-control bail to disengage the mower blades.

Upper Control Bar

Shift to the desired gear and push the upper control bar forward to engage the forward traction operation. Pull back to brake the forward movement.

Pull back on the right side of the upper control bar to turn right or pull it back on the left side to turn left.

Lower Control Bar

Shift the transmission to the REVERSE position and squeeze the lower control bar and handle together to engage the rearward traction assist.

Parking-Brake Lever

Pull back on the upper control bar and swing the brake lever upward against the upper handle to engage the parking brake.

Specifications

Note: Specifications and design are subject to change without notice.

32-inch mowers:

Width with deflector down	116 cm (46 inches)
Length	183 cm (72 inches)
Height	104 cm (41 inches)
Weight	181 kg (400 lb)

36-inch mowers:

Width with deflector down	118 cm (47 inches)
Length	188 cm (74 inches)
Height	104 cm (41 inches)
Weight	209 kg (460 lb)

Attachments/Accessories

A selection of Toro approved attachments and accessories is available for use with the machine to enhance and expand its capabilities. Contact your Authorized Service Dealer or authorized Toro distributor or go to www.Toro.com for a list of all approved attachments and accessories.

To ensure optimum performance and continued safety certification of the machine, use only genuine Toro replacement parts and accessories. Replacement parts and accessories made by other manufacturers could be dangerous, and such use could void the product warranty.

Operation

Note: Determine the left and right sides of the machine from the normal operating position.

Before Operation

Before Operation Safety

General Safety

- Do not allow children or untrained people to operate or service the machine. Local regulations may restrict the age of the operator. The owner is responsible for training all operators and mechanics.
- Become familiar with the safe operation of the equipment, operator controls, and safety signs.
- Always shut off the machine, remove the ignition key (if equipped), wait for all moving parts to stop, and allow the machine to cool before adjusting, servicing, cleaning, or storing it.
- Know how to stop the machine and shut off the engine quickly.
- Check that operator-presence controls, safety switches, and safety protective devices are attached and functioning properly. Do not operate the machine unless they are functioning properly.
- Inspect the area where you will use the machine, and remove all objects that could interfere with the operation of the machine or that the machine could throw.
- Evaluate the terrain to determine what accessories and attachments are needed to properly and safely perform the job.
- Before using, always visually inspect to see that the blades, blade bolts and mower deck are not worn or damaged. Replace worn or damaged blades and bolts in sets to preserve balance.

Fuel Safety

- Use extreme care in handling fuel. It is flammable and its vapors are explosive.
- Extinguish all cigarettes, cigars, pipes, and other sources of ignition.
- Use only an approved fuel container.
- Do not remove the fuel cap or add fuel to the tank while the engine is running or hot.
- Do not add or drain fuel in an enclosed space.
- Do not store the machine or fuel container where there is an open flame, spark, or pilot light, such as on a water heater or other appliance.

- If you spill fuel, do not attempt to start the engine; avoid creating a source of ignition until the fuel vapors have dissipated.
- Do not fill containers inside a vehicle or on a truck or trailer bed with a plastic liner. Always place containers on the ground, away from the vehicle before filling.
- Remove equipment from the truck or trailer and refuel it on the ground. If this is not possible, refuel such equipment with a portable container rather than from a fuel-dispenser nozzle.
- Keep the nozzle in contact with the rim of the fuel tank or container operating at all times until fueling is complete.

Adding Fuel

Recommended Fuel

- For best results, use only clean, fresh (less than 30 days old), unleaded gasoline with an octane rating of 87 or higher ((R+M)/2 rating method).
- **Ethanol:** Gasoline with up to 10% ethanol (gasohol) or 15% MTBE (methyl tertiary butyl ether) by volume is acceptable. Ethanol and MTBE are not the same. Gasoline with 15% ethanol (E15) by volume is not approved for use. **Never use gasoline that contains more than 10% ethanol by volume**, such as E15 (contains 15% ethanol), E20 (contains 20% ethanol), or E85 (contains up to 85% ethanol). Using unapproved gasoline may cause performance problems and/or engine damage which may not be covered under warranty.
- **Do not** use gasoline containing methanol.
- **Do not** store fuel either in the fuel tank or fuel containers over the winter unless you use a fuel stabilizer.
- **Do not** add oil to gasoline.

Using Stabilizer/Conditioner

Use a fuel stabilizer/conditioner in the machine to provide the following benefits:

- Keeps fuel fresh longer when used as directed by the fuel-stabilizer manufacturer
- Cleans the engine while it runs
- Eliminates gum-like varnish buildup in the fuel system, which causes hard starting

Important: Do not use fuel additives containing methanol or ethanol.

Add the correct amount of fuel stabilizer/conditioner to the fuel.

Note: A fuel stabilizer/conditioner is most effective when mixed with fresh fuel. To minimize the chance of varnish deposits in the fuel system, use fuel stabilizer at all times.

Filling the Fuel Tank

1. Park the machine on a level surface.
2. Engage the parking brake.
3. Shut off the engine and remove the key.
4. Clean around the fuel-tank cap.
5. Fill the fuel tank to the bottom of the filler neck.

Note: Do not fill the fuel tank completely full. The empty space in the tank allows the fuel to expand.

Performing Daily Maintenance

Before starting the machine each day, perform the Each Use/Daily procedures listed in [Maintenance \(page 24\)](#).

Using the Safety-Interlock System

⚠ WARNING

If the safety-interlock switches are disconnected or damaged, the machine could operate unexpectedly, causing personal injury.

- Do not tamper with the interlock switches.
- Check the operation of the interlock switches daily and replace any damaged switches before operating the machine.

Understanding the Safety-Interlock System

The safety-interlock system is designed to prevent the engine from starting unless:

- The blade-control lever (PTO) is engaged.
- The ignition key is turned to the OFF position.

The safety-interlock system is designed to shut off the engine when:

- The-blade control bail is released with the blade-control lever (PTO) engaged.
- The ignition key is turned to the OFF position.

Testing the Safety-Interlock System

Test the safety-interlock system each time before you use the machine. If the safety system does not operate as described, have an Authorized Service Dealer repair the safety system immediately.

1. Engage the parking brake, disengage the PTO, and move the throttle forward.
2. Start the engine.
3. With the engine running, squeeze the blade-control bail against the upper control bar, and push the blade-control lever (PTO) forward.

The mower blades should rotate.

4. With the engine running, release the blade-control bail.

The engine should shut off.

5. Start the engine.
6. With the engine running, turn the ignition key to the OFF position.

The engine should shut off.

During Operation

During Operation Safety

General Safety

- The owner/operator can prevent and is responsible for accidents that may cause personal injury or property damage.
- Wear appropriate clothing, including eye protection; long pants; substantial, slip-resistant footwear; and hearing protection. Tie back long hair and do not wear loose clothing or loose jewelry.
- Use your full attention while operating the machine. Do not engage in any activity that causes distractions; otherwise, injury or property damage may occur.
- Do not operate the machine while ill, tired, or under the influence of alcohol or drugs.
- Before you start the engine, ensure that all drives are in neutral, the parking brake is engaged, and you are in the operating position.
- Keep bystanders out of the operating area. Stop the machine if anyone enters the area.
- Operate the machine only in good visibility and appropriate weather conditions. Do not operate the machine when there is the risk of lightning.

- Wet grass or leaves can cause serious injury if you slip and contact the blade. Avoid mowing in wet conditions.
- Keep your hands and feet away from the cutting unit.
- Look behind and down before backing up to be sure of a clear path.
- Use extreme care when approaching blind corners, shrubs, trees, or other objects that may block your view.
- Disengage the drive to the cutting unit and engage the parking brake before adjusting the height of cut.
- Operate the engine only in well-ventilated areas. Exhaust gases contain carbon monoxide, which is lethal if inhaled.
- Do not leave a running machine unattended.
- Before leaving the operating position (including to empty the catchers or to unclog the cutting units), do the following:
 - Park the machine on level ground.
 - Disengage the cutting unit and lower the attachments.
 - Engage the parking brake.
 - Shut off the machine and remove the ignition key (if equipped).
 - Wait for all moving parts to stop.
 - Shut off the machine and disengage the drive to the cutting unit in the following situations:
 - ◇ Before fueling
 - ◇ Before clearing blockages
 - ◇ Before checking, cleaning, or maintaining the cutting unit
 - ◇ After striking a foreign object or if an abnormal vibration occurs. Inspect the cutting unit for damage and make repairs before starting and operating the machine
 - ◇ Before leaving the operating position
 - Use only accessories and attachments approved by The Toro® Company.
 - Be sure of your footing while using this machine, especially when backing up. Walk; do not run.
 - Never operate with the discharge deflector raised, removed or altered, unless you are using a grass catcher.
 - Never carry passengers on the machine.
 - Do not direct the discharge material toward anyone. Avoid discharging material against a wall or obstruction; material may ricochet toward you. Stop the blade(s) when crossing gravel surfaces.
- Start the engine carefully according to instructions and with your feet well away from the blade(s) and not in front of the discharge chute.
- Use extreme caution when reversing or pulling the machine toward you.
- Stop the blade if you must transport the machine to and from the mowing area and when crossing surfaces other than grass.

Slope Safety

- Slopes are a major factor related to loss of control and rollover accidents, which can result in severe injury or death. You are responsible for safe slope operation. Operating the machine on any slope requires extra caution. Before using the machine on a slope, do the following:
 - Review and understand the slope instructions in the manual and on the machine.
 - Evaluate the site conditions of the day to determine if the slope is safe for machine operation. Use common sense and good judgment when performing this evaluation. Changes in the terrain, such as moisture, can quickly affect the operation of the machine on a slope.
- Operate across slopes, never up and down. Avoid operation on excessively steep or wet slopes. Poor footing could cause a slip-and-fall accident.
- Identify hazards at the base of the slope. Do not operate the machine near drop-offs, ditches, embankments, water, or other hazards. The machine could suddenly roll over if a wheel goes over the edge or the edge collapses. Keep a safe distance between the machine and any hazard. Use a handheld tool to operate in these areas.
- Avoid starting, stopping, or turning the machine on slopes. Avoid making sudden changes in speed or direction; turn slowly and gradually.
- Do not operate a machine under any conditions where traction, steering or stability is in question. Be aware that operating the machine on wet grass, across slopes or downhill may cause the machine to lose traction. Loss of traction to the drive wheels may result in sliding and a loss of braking and steering. The machine can slide even if the drive wheels are stopped.
- Remove or mark obstacles such as ditches, holes, ruts, bumps, rocks, or other hidden hazards. Tall grass can hide obstacles. Uneven terrain could overturn the machine.

- If you lose control of the machine, step away from the direction of travel of the machine.
- Always keep the machine in gear when going down slopes. Do not coast downhill (applicable only to gear-drive units).

Operating the Parking Brake

⚠ WARNING

Children or bystanders may be injured if they move or attempt to operate the machine while it is unattended.

Always park the machine on a level surface, engage the parking brake, and remove the ignition key if you leave the machine unattended.

Engaging the Parking Brake

1. Pull the upper control bar rearward and hold it in this position (Figure 5).
2. Lift the parking-brake lever upward and gradually release the upper control bar.

The parking-brake lever should stay in the engaged position (Figure 5).

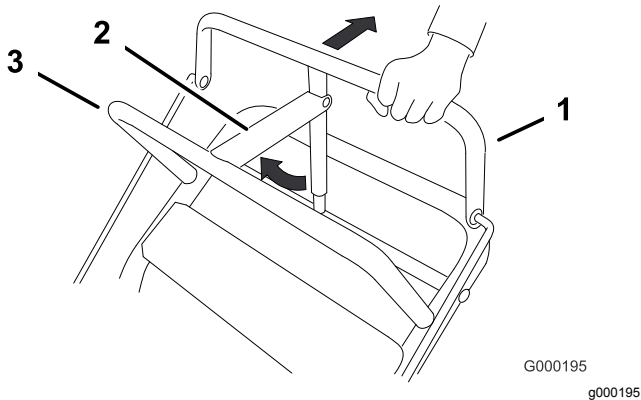

Figure 5

1. Upper control bar
2. Parking-brake lever—engaged position
3. Fixed bar

Disengaging the Parking Brake

1. Pull rearward on the upper control bar and lower the parking-brake lever to the disengaged position.
2. Gradually release the upper control bar.

Starting the Engine

1. Connect the spark-plug wires.
2. Open the fuel valve.
3. Disengage the PTO and shift to the NEUTRAL position.
4. Engage the parking brakes.
5. Turn the ignition key to the RUN position.
 - To start a cold engine, move the throttle control midway between the FAST and SLOW positions.
 - To start a warm engine, move the throttle control to the FAST position.
6. Pull the choke knob if the engine is cold.
7. Grasp the recoil-start handle firmly and pull it to start the engine.

Note: A warm or hot engine usually does not require any choking.

Note: Allow the rope to recoil slowly.

Important: Do not pull the recoil rope to its limit or release the starter handle when you pull out the rope, because the rope may break or the recoil assembly may be damaged.

8. Push the choke to the OFF position as the engine warms up.
9. If the engine is cold, allow it to warm up and then move the throttle control to the FAST position.

Shutting Off the Engine

Important: In an emergency, you can stop the engine immediately by turning the ignition key to the Off position.

1. Move the throttle lever to the SLOW position (Figure 6).
2. Idle the engine for 30 to 60 seconds before turning the ignition key to the OFF position.

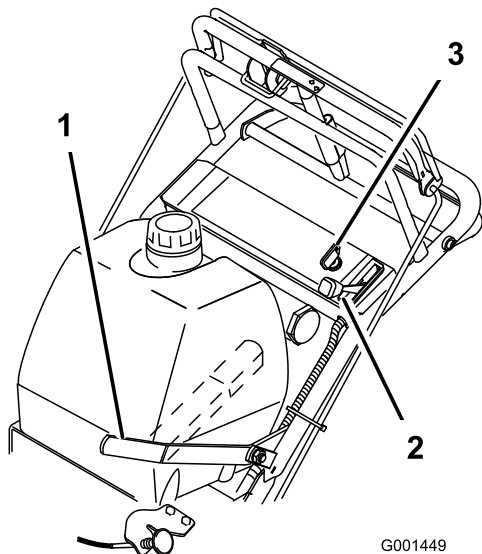

Figure 6

1. Blade-control lever (PTO)
2. Throttle lever
3. Ignition key

3. Engage the parking brakes and remove the ignition key.
4. Disconnect the spark-plug wires.
5. Close the fuel-shutoff valve.

Important: Ensure that you close the fuel-shutoff valve before transporting or storing the machine, as fuel may leak.

Operating the Blade-Control Lever (PTO)

The blade-control lever (PTO) engages and disengages power to the mower blades.

Engaging the Mower Blades

1. Squeeze the blade-control bail against the upper control bar (Figure 7).
2. Push the blade-control lever (PTO) firmly forward, until it latches over the center.

Note: If you release the blade-control bail, start the engine and repeat this procedure to engage the mower blades.

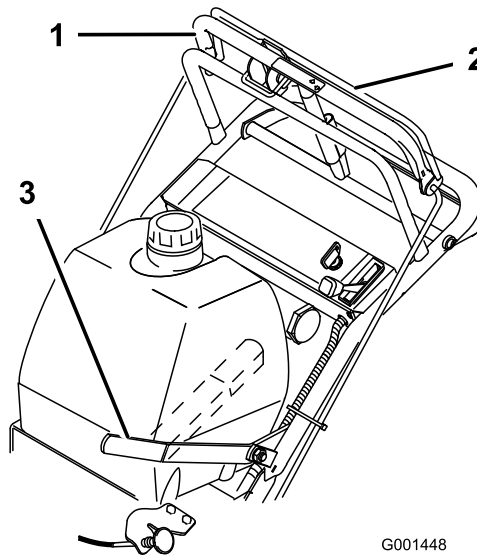

Figure 7

1. Upper control bar
2. Blade-control bail
3. Blade-control lever (PTO)

Disengaging the Mower Blades

Pull the blade-control lever (PTO) fully rearward (Figure 7).

Note: The engine shuts off if you release the blade-control bail with the blade-control lever engaged.

Driving the Machine

The throttle control regulates the engine speed (rpm). Move the throttle control to the FAST position for the best mowing performance.

⚠ WARNING

The machine can spin very rapidly. You may lose control of the machine and cause personal injury or damage to the machine.

- Use caution when making turns.
- Slow the machine down before making sharp turns.

Driving Forward

1. Move the shift lever to a forward gear (Figure 8).
2. Disengage the parking brake.
3. Slowly press on the upper control bar to move forward (Figure 8).

To go straight, apply equal pressure to both ends of the upper control bar (Figure 8).

To turn, release pressure on the upper control bar side in the direction you want to turn (Figure 8).

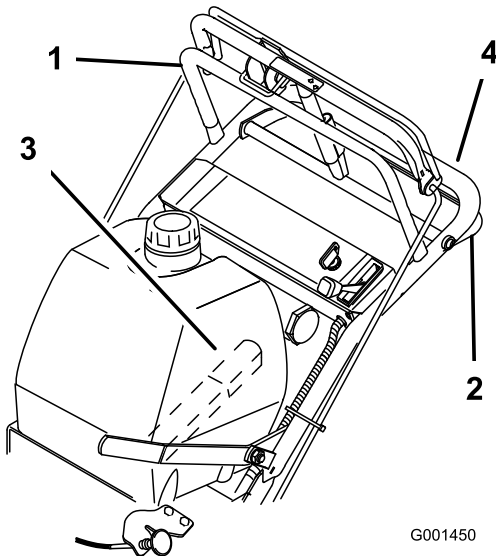

Figure 8

- | | |
|----------------------|-----------------|
| 1. Upper control bar | 3. Shift lever |
| 2. Lower control bar | 4. Lower handle |

Driving Backward

1. Move the shift lever to the reverse gear.
2. Disengage the parking brake.
3. Slowly squeeze the lower control bar and lower handle together to move rearward (Figure 8).

Using the Lower Control Bar

This procedure is for driving up a curb. You can do this while driving forward or backward.

Note: Some curbs do not allow the rear drive tires to contact the curb. If this happens, drive the machine up the curb at an angle.

⚠ WARNING

A blade can be bent or damaged when driving up a curb. Pieces of blade may be thrown and could seriously injure or kill you or bystanders.

Do not engage the blades while driving up a curb.

Driving Forward up a Curb

1. Disengage the mower blades.
2. Select the FIRST GEAR position to drive the machine.
3. Drive machine until the caster wheels contact the curb (Figure 9).
4. Lift the front of the machine by pushing down on the lower handle (Figure 9).
5. Drive the machine until the drive wheels contact the curb (Figure 9).
6. Lower the front of the machine (Figure 9).
7. At the same time, engage the lower control bar and lift up the lower handle to drive over the curb (Figure 9 and Figure 10).

Note: Both drive wheels should contact the curb and the caster wheels should be straight.

Note: Lifting up the lower handle assists with driving the machine up a curb and not spinning the drive wheels.

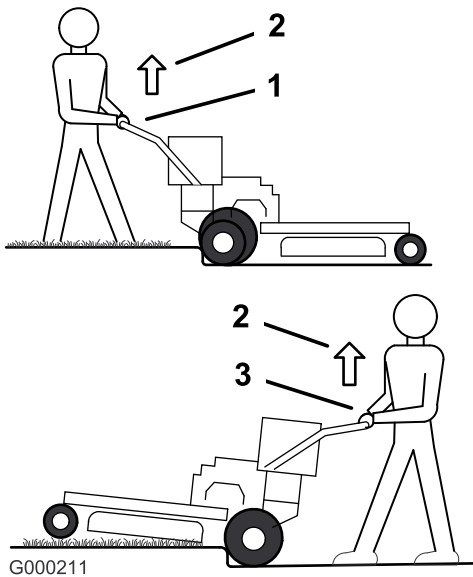

Figure 9

- | | |
|---|--|
| <ol style="list-style-type: none"> 1. Lower control bar—engaged and the machine going reverse 2. Pull up to assist the machine. | <ol style="list-style-type: none"> 3. Lower control bar—engaged and the machine going forward |
|---|--|

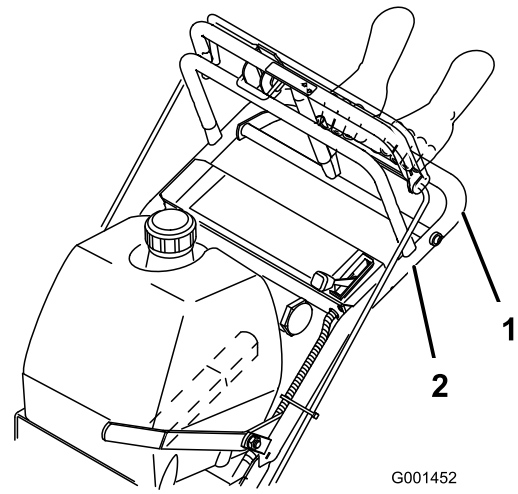

Figure 10

1. Lower control bar—engaged
2. Handle

Driving Backward up a Curb

1. Disengage the mower blades.
2. Select the REVERSE position to drive the machine.
3. Drive the machine until the drive wheels contact the curb (Figure 9).

Note: Both drive wheels should contact the curb and the caster wheels should be straight.

4. At the same time, engage the lower control bar and lift up the lower handle (Figure 9 and Figure 10).

Note: Lifting up the lower handle assists with driving the machine up a curb and not spinning the drive wheels.

Stopping the Machine

CAUTION

You or bystanders may be injured if you move or attempt to operate the machine while it is unattended.

Always remove the ignition key and engage the parking brake if you leave the machine unattended.

1. Pull back the upper control bar and release the blade-control bail.
2. Engage the parking brake.
3. Turn the ignition key to the OFF position and remove the key.

Adjusting the Flow Baffle

You can adjust the mower discharge flow for different types of mowing conditions. Position the cam lock and baffle for the best quality of cut.

1. Disengage the PTO and engage the parking brake.
2. Shut off the engine, remove the key, and wait for all moving parts to stop before leaving the operating position.
3. Loosen the nut (Figure 11).
4. Adjust the baffle and nut in the slot to the desired discharge flow.
5. Tighten the nut.

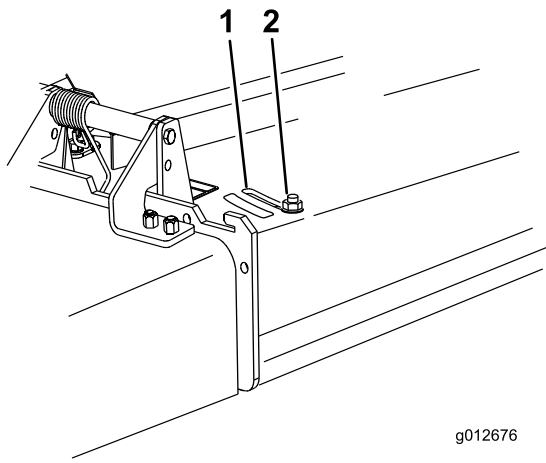

Figure 11

1. Slot

2. Nut

g012676

g012676

Position B

Use this position when bagging.

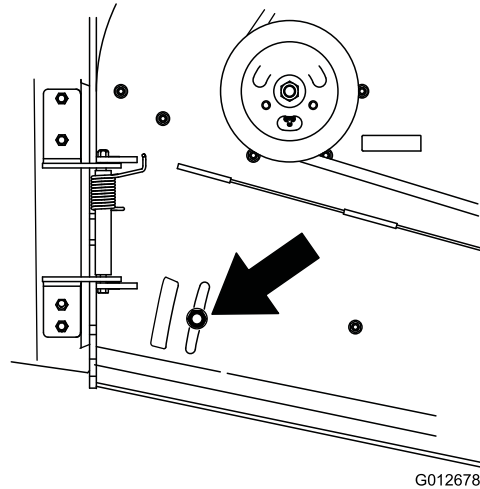

Figure 13

G012678

g012678

Positioning the Flow Baffle

The following figures are only recommendations for use. Adjustments vary by grass type, moisture content, and the height of the grass.

Note: If the engine power draws down and the mower ground speed is the same, open up the baffle.

Position A

This is the full rear position. The suggested use for this position is as follows:

- Short, light grass mowing conditions
- Dry conditions
- Smaller grass clippings
- Propels grass clippings farther away from the mower

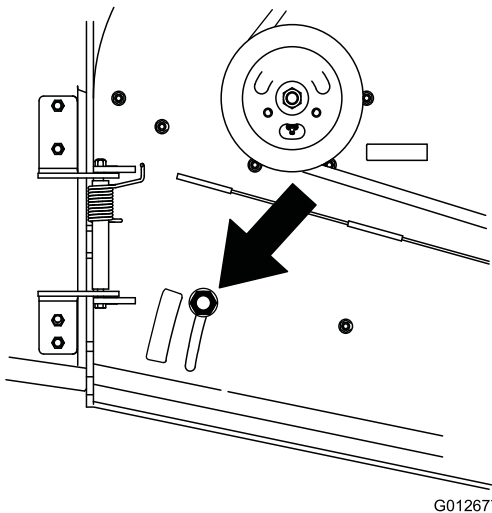

Figure 12

G012677

g012677

Position C

This is the full open position. The suggested use for this position is as follows:

- Tall, dense grass mowing conditions
- Wet conditions
- Lowers the engine-power consumption
- Allows increased ground speed in heavy conditions

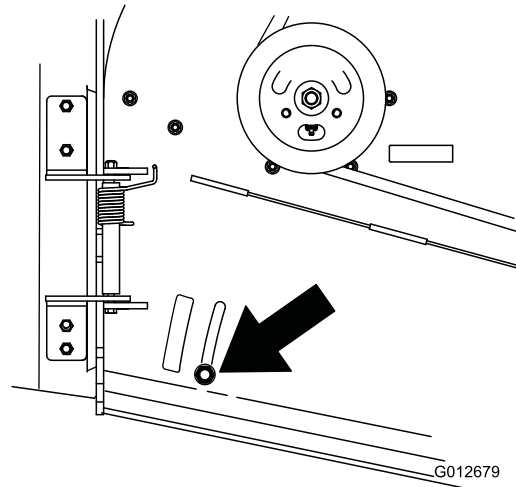

Figure 14

G012679

g012679

Side Discharging or Mulching Grass

This mower has a hinged grass deflector that disperses clippings to the side and down toward the turf.

⚠ DANGER

Without the grass deflector, discharge cover, or complete grass catcher assembly mounted in place, you and bystanders are exposed to blade contact and thrown debris. Contact with rotating mower blade(s) and thrown debris can cause serious injury or death.

- Never remove the grass deflector from the mower deck, because the grass deflector routes material down toward the turf. If the grass deflector is damaged, replace it immediately.
- Never put your hands or feet under the mower deck.
- Never try to clear the discharge area or mower blades before you disengage the mower blades. Turn the ignition key to the OFF position. Remove the key and disconnect the spark-plug wires.

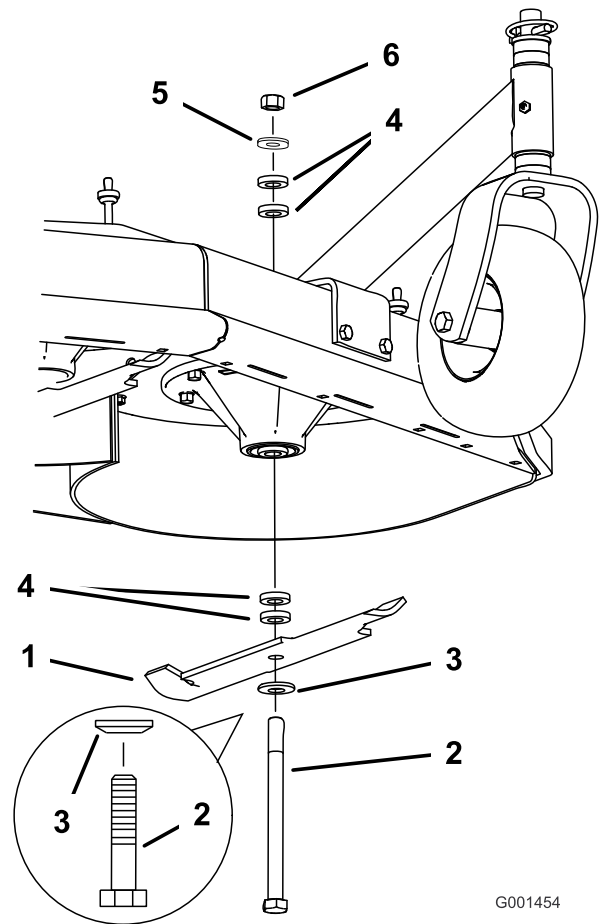

G001454

g001454

Figure 15

- | | |
|------------------|----------------|
| 1. Blade | 4. Spacer |
| 2. Blade bolt | 5. Thin washer |
| 3. Curved washer | 6. Nut |

Adjusting the Height of Cut

You can adjust the height of cut from 26 to 108 mm (1 to 4-1/4 inches) in 6 mm (1/4 inch) increments. You can achieve this by adjusting the blade spacers, rear axle height, or front caster spacers. Use the [Height-of-Cut Chart \(page 22\)](#) to select the combination of adjustments required.

Adjusting the Blade Height

Adjust the blades by using the 4 spacers (6 mm or 1/4 inch) on the blade spindle bolts. This allows for a 25 mm (1 inch) adjustment range, in 6 mm (1/4 inch) increments, of cutting height in any axle position. Use the same number of blade spacers on all the blades to achieve a level cut (for example, 2 above and 2 below, 1 above and 3 below, etc.).

1. Park the machine on a level surface, disengage the PTO, and engage the parking brake.
2. Shut off the engine, remove the key, and wait for all moving parts to stop before leaving the operating position.
3. Hold the blade bolt and remove the nut ([Figure 15](#)).

4. Remove the blade bolt from the spindle and change the spacers as needed ([Figure 15](#)).
5. Install the blade bolt, curved washer, and extra spacers, and secure them with a thin washer and a nut ([Figure 15](#)).
6. Torque the blade bolt to 101 to 108 N·m (75 to 80 ft-lb).

Adjusting the Axle Height

Adjust the axle position to the selected height-of-cut setting. Refer to the [Height-of-Cut Chart \(page 22\)](#).

1. Park the machine on a level surface, disengage the PTO, and engage the parking brake.
2. Shut off the engine, remove the key, and wait for all moving parts to stop before leaving the operating position.
3. Loosen, but do not remove, the 2 axle-pivot bolts and 2 axle-adjustment bolts ([Figure 16](#)).

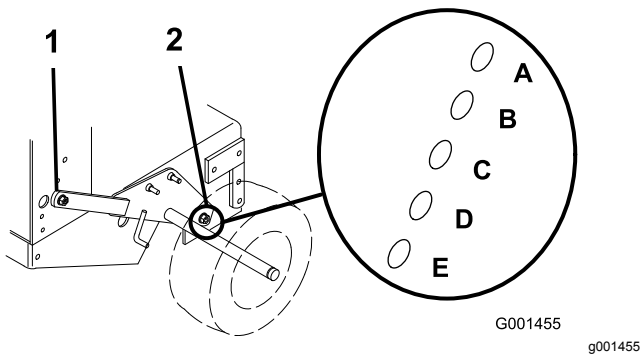

Figure 16

1. Axle-pivot bolt
2. Axle-adjustment bolt

4. Place a jack under the rear center of the engine frame. Raise the rear end of the engine frame up enough to remove the front 2 axle-adjustment bolts (Figure 16).

Note: Use jack stands to support the machine.

5. Raise or lower the engine frame with the jack so that you can install the front 2 axle-adjustment bolts in the desired hole location (Figure 16).

Note: Use a tapered punch to help align the holes.

6. Tighten all 4 bolts and lower the machine.
7. Adjust the control rods and brake linkages as required; refer to [Adjusting the Control Rods \(page 21\)](#) and [Adjusting the Parking Brake \(page 33\)](#).

Important: You must adjust the control rods and brake linkage when you change the axle positions for proper traction and brake function.

Adjusting the Caster Position

1. Using the [Height-of-Cut Chart \(page 22\)](#), adjust the caster spacers to match with the axle hole selected (Figure 17).

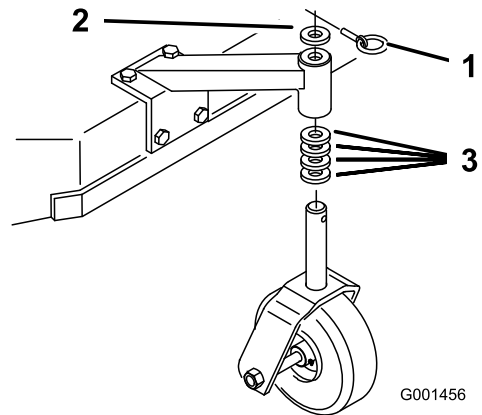

Figure 17

1. Latch pin
2. Spacer (5 mm or 3/16 inch)
3. Spacer (13 mm or 1/2 inch)

2. Remove the latch pin, slide the caster from the support, and change the spacers (Figure 17).
3. Install the caster in the support and insert the latch pin (Figure 17).

Adjusting the Control Rods

1. With the wheel drive fully engaged, check the gap between the upper control bar and the fixed bar. The gap needs to be approximately 25 to 32 mm (1 to 1-1/4 inches) as shown in [Figure 18](#).

Note: The upper control bar and the fixed bar must be parallel in the engaged, relaxed, and brake positions.

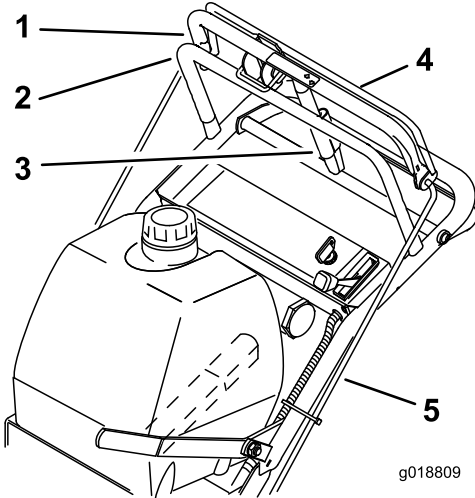

Figure 18

- | | |
|--|----------------------|
| 1. 25 to 32 mm (1 to 1-1/4 inches) gap | 4. Upper control bar |
| 2. Fixed control bar | 5. Control rod |
| 3. Parking-brake lever | |

-
2. Check the operation. If adjustment is required, remove the hairpin cotter securing the rod to the upper control bar. Thread the rod in or out of the control rod fitting for proper position and install the control rod into the upper control bar with the hairpin cotter.
 3. After adjusting the control rods, check the parking brake adjustment; refer to [Brake Maintenance \(page 33\)](#).

Height-of-Cut Chart

Axle position	Number of spacers below the caster		Number of 1/4-inch blade spacers below the spindle				
	13 mm (1/2 inch)	5 mm (3/16 inch)	4	3	2	1	0
A	0	0	26 mm (1 inch)	32 mm (1-1/4 inches)	38 mm (1-1/2 inches)	45 mm (1-3/4 inches)	51 mm (2 inches)
A	0	1	29 mm (1-1/8 inches)	35 mm (1-3/8 inches)	41 mm (1-5/8 inches)	48 mm (1-7/8 inches)	54 mm (2-1/8 inches)
A	1	0	35 mm (1-3/8 inches)	41 mm (1-5/8 inches)	48 mm (1-7/8 inches)	54 mm (2-1/8 inches)	60 mm (2-3/8 inches)
B	0	1	35 mm (1-3/8 inches)	41 mm (1-5/8 inches)	48 mm (1-7/8 inches)	54 mm (2-1/8 inches)	60 mm (2-3/8 inches)
B	1	0	41 mm (1-5/8 inches)	48 mm (1-7/8 inches)	54 mm (2-1/8 inches)	60 mm (2-3/8 inches)	67 mm (2-5/8 inches)
B	1	1	45 mm (1-3/4 inches)	51 mm (2 inches)	57 mm (2-1/4 inches)	64 mm (2-1/2 inches)	70 mm (2-3/4 inches)
B	2	0	51 mm (2 inches)	57 mm (2-1/4 inches)	64 mm (2-1/2 inches)	70 mm (2-3/4 inches)	76 mm (3 inches)
C	1	1	48 mm (1-7/8 inches)	54 mm (2-1/8 inches)	60 mm (2-3/8 inches)	67 mm (2-5/8 inches)	73 mm (2-7/8 inches)
C	2	0	55 mm (2-1/8 inches)	60 mm (2-3/8 inches)	67 mm (2-5/8 inches)	73 mm (2-7/8 inches)	79 mm (3-1/8 inches)
C	2	1	57 mm (2-1/4 inches)	64 mm (2-1/2 inches)	70 mm (2-3/4 inches)	76 mm (3 inches)	83 mm (3-1/4 inches)
C	3	0	64 mm (2-1/2 inches)	70 mm (2-3/4 inches)	76 mm (3 inches)	83 mm (3-1/4 inches)	89 mm (3-1/2 inches)
D	2	1	61 mm (2-3/8 inches)	67 mm (2-5/8 inches)	73 mm (2-7/8 inches)	79 mm (3-1/8 inches)	86 mm (3-3/8 inches)
D	3	0	64 mm (2-1/2 inches)	70 mm (2-3/4 inches)	76 mm (3 inches)	82 mm (3-1/4 inches)	89 mm (3-1/2 inches)
D	3	1	70 mm (2-3/4 inches)	76 mm (3 inches)	82 mm (3-1/4 inches)	89 mm (3-1/2 inches)	95 mm (3-3/4 inches)
D	4	0	76 mm (3 inches)	82 mm (3-1/4 inches)	89 mm (3-1/2 inches)	95 mm (3-3/4 inches)	102 mm (4 inches)
E	3	1	73 mm (2-7/8 inches)	79 mm (3-1/8 inches)	86 mm (3-3/8 inches)	92 mm (3-5/8 inches)	98 mm (3-7/8 inches)
E	4	0	79 mm (3-1/8 inches)	86 mm (3-3/8 inches)	92 mm (3-5/8 inches)	98 mm (3-7/8 inches)	105 mm (4-1/8 inches)
E	4	1	82 mm (3-1/4 inches)	89 mm (3-1/2 inches)	95 mm (3-3/4 inches)	102 mm (4 inches)	108 mm (4-1/4 inches)

After Operation

After Operation Safety

General Safety

- Always shut off the machine, remove the ignition key (if equipped), wait for all moving parts to stop, and allow the machine to cool before adjusting, servicing, cleaning, or storing it.
- Clean grass and debris from the machine to help prevent fires. Clean up oil or fuel spills.
- Never store the machine or fuel container where there is an open flame, spark, or pilot light, such as on a water heater or on other appliances.
- Use full-width ramps for loading the machine into a trailer or truck.
- Tie the machine down securely using straps, chains, cable, or ropes. Direct both front and rear straps down and outward from the machine.

Hauling the Machine

Use a heavy-duty trailer or truck to transport the machine. Ensure that the trailer or truck has all the necessary brakes, lighting, and marking required by the law. Carefully read all the safety instructions.

1. If using a trailer, connect it to the towing vehicle and connect the safety chains.
2. If applicable, connect the trailer brakes.
3. Load the machine on to the trailer or truck.
4. Park the machine on a level surface, engage the parking brake, shut off the engine, remove the key, and close the fuel valve.
5. Use the tie-down loops on the machine to securely fasten the machine to the towing vehicle with straps, chains, cable, or ropes (Figure 19).

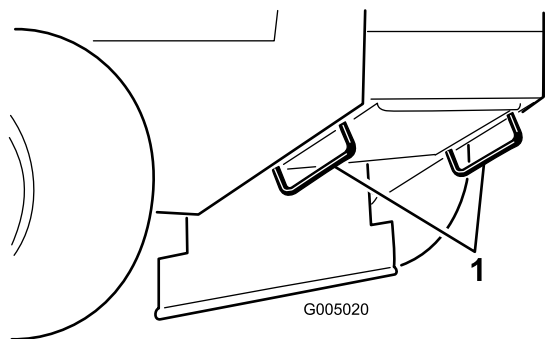

Figure 19

1. Tie-down loops

Maintenance

Note: Determine the left and right sides of the machine from the normal operating position.

Maintenance Safety

- Before adjusting, cleaning, servicing, or leaving the machine, do the following:
 - Park the machine on a level surface.
 - Move the throttle switch to the low-idle position.
 - Disengage the cutting units.
 - Ensure that the transmission is in neutral.
 - Engage the parking brake.
 - Shut off the engine and remove the key.
 - Wait for all moving parts to stop.
 - Allow machine components to cool before performing maintenance.
- Do not allow untrained personnel to service the machine.
- If the engine must be running to perform a maintenance adjustment, keep your hands, feet, clothing, and any parts of the body away from the cutting unit, attachments, and any moving parts. Keep bystanders away.
- Keep all parts in good working condition. Replace all worn, damaged, or missing parts and decals. Keep all fasteners tight to ensure that the machine is in safe working condition.
- Check the grass catcher components frequently and replace them when they are worn or damaged.
- Clean grass and debris from the cutting unit, drives, muffler, cooling screen, and the engine to help prevent fires. Clean up oil or fuel spills.
- Check the brake operation frequently. Adjust and service the brake as needed.
- Carefully release pressure from components with stored energy.
- To ensure safe, optimal performance of the machine, use only genuine Toro replacement parts. Replacement parts made by other manufacturers could be dangerous, and such use could void the product warranty.

Recommended Maintenance Schedule(s)

Maintenance Service Interval	Maintenance Procedure
After the first 8 hours	<ul style="list-style-type: none"> • Change the engine oil. • Check the mower belt tension.
After the first 25 hours	<ul style="list-style-type: none"> • Check the mower belt tension.
Before each use or daily	<ul style="list-style-type: none"> • Check the safety-interlock system. • Grease the caster wheels and caster pivot. • Check the engine-oil level. • Clean the air-intake screen. • Clean the grass and debris from the air-intake screen. • Check the parking brake. • Inspect the blades. • Clean the mower deck.
Every 25 hours	<ul style="list-style-type: none"> • Clean the foam air-cleaner element. • Check the belts for wear or cracks.
Every 50 hours	<ul style="list-style-type: none"> • Grease the mower belt idler. • Check the paper air-cleaner element. • Check the tire pressure. • Check the traction-drive belt. • Check the mower belt tension.
Every 100 hours	<ul style="list-style-type: none"> • Change the engine oil. • Check the spark plugs. • Check and clean the engine-cooling fins and shrouds.

Maintenance Service Interval	Maintenance Procedure
Every 200 hours	<ul style="list-style-type: none"> • Replace the paper air-cleaner element. • Change the engine-oil filter. • Replace the fuel filter. • Replace the fuel-vent filter.
Every 250 hours	<ul style="list-style-type: none"> • Grease the transmission couplers (more often in dirty or dusty conditions).
Every 400 hours	<ul style="list-style-type: none"> • Grease the wheel bearings (more often in dirty or dusty conditions).

Important: Refer to your engine owner's manual for additional maintenance procedures.

⚠ CAUTION

If you leave the key in the switch, someone could accidentally start the engine and seriously injure you or other bystanders.

Shut off the engine and remove the key from the switch before you perform any maintenance.

Lubrication

Greasing the Machine

Grease the machine more often in dirty or dusty conditions.

Grease Type: No. 2 lithium or molybdenum grease

1. Park the machine on a level surface, disengage the blade-control switch (PTO), and engage the parking brake.
2. Shut off the engine, remove the key, and wait for all moving parts to stop before leaving the operating position.
3. Clean the grease fittings with a rag.

Note: Scrape any paint off the front of the fitting(s).

4. Pump grease into the fittings until grease begins to ooze out of the bearings.
5. Wipe up any excess grease.

Lubricating the Caster and Wheel Bearings

1. Lubricate the front wheel bearings and front spindles (Figure 20).
2. Lubricate the drive-wheel bearings (Figure 20).

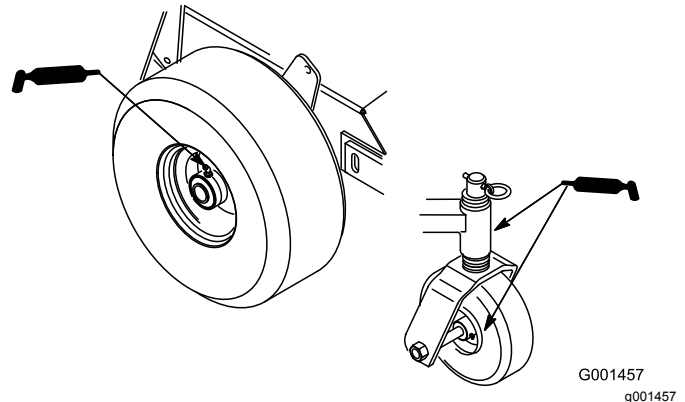

Figure 20

G001457
g001457

Greasing the Transmission Couplers

Lubricate the transmission couplers and idler-arm pivots located at the rear of the machine (Figure 21).

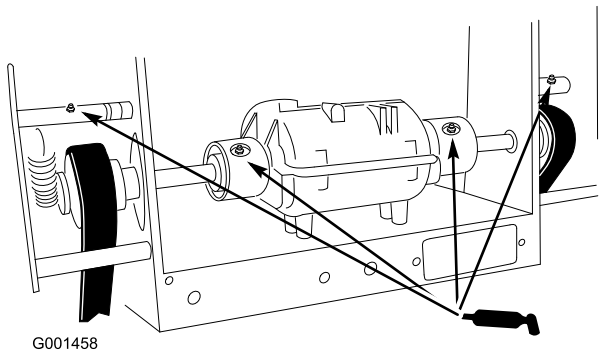

Figure 21

Greasing the Mower Belt Idler

Grease the fitting on the mower belt idler arm pivot (Figure 22).

Note: Remove the mower deck cover to access the grease fitting for the mower belt idler arm.

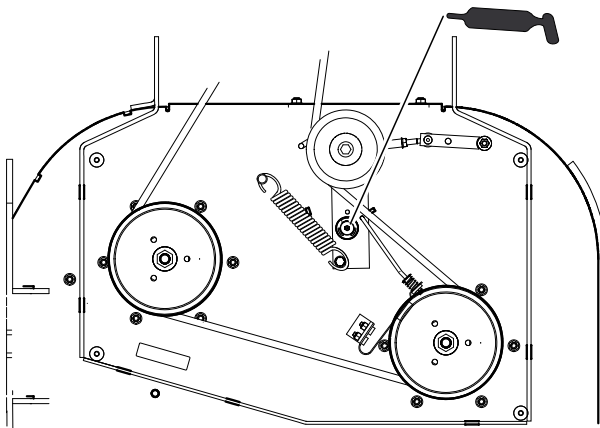

Figure 22

Engine Maintenance

Engine Safety

- Do not change the governor speed or overspeed the engine.
- Run the engine dry or remove the fuel with a hand pump; never siphon the fuel. If you must drain the fuel tank, do it outdoors.

Servicing the Air Cleaner

Service Interval: Every 25 hours—Clean the foam air-cleaner element.

Every 50 hours—Check the paper air-cleaner element.

Every 200 hours—Replace the paper air-cleaner element.

Note: Service the air cleaner more frequently (every few operating hours) if the operating conditions are extremely dusty or sandy.

Important: Do not apply oil to the foam or paper element.

Removing the Foam and Paper Elements

1. Park the machine on a level surface, disengage the PTO, and engage the parking brake.
2. Shut off the engine, remove the key, and wait for all moving parts to stop before leaving the operating position.
3. Clean the area around the air cleaner to prevent dirt from entering the engine and causing damage (Figure 23).
4. Unscrew the cover knobs and remove the air-cleaner cover (Figure 23).
5. Unscrew the hose clamp and remove the air-cleaner assembly (Figure 23).
6. Carefully pull the foam element off the paper element (Figure 23).

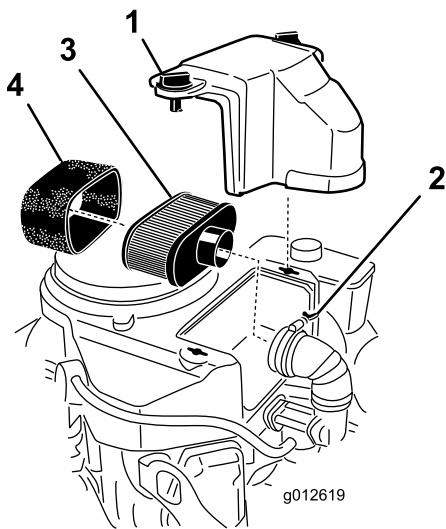

Figure 23

1. Cover
2. Hose clamp
3. Paper element
4. Foam element

Cleaning the Foam Air-Cleaner Element

1. Wash the foam element in liquid soap and warm water. When the element is clean, rinse it thoroughly.
2. Dry the element by squeezing it in a clean cloth.

Important: Replace the foam element if it is torn or worn.

Servicing the Paper Air-Cleaner Element

Important: Do not clean the paper filter, replace it (Figure 23).

1. Inspect the element for tears, an oily film, or damage to the rubber seal.
2. Replace the paper element if it is damaged.

Installing the Foam and Paper Elements

Important: To prevent engine damage, always operate the engine with the complete foam and paper air-cleaner assembly installed.

1. Carefully slide the foam element on to the paper air-cleaner element (Figure 23).
2. Place the air-cleaner assembly onto the air cleaner base and secure it with the 2 wing nuts (Figure 23).
3. Place the air-cleaner cover into position and tighten the cover knob (Figure 23).

Servicing the Engine Oil

Note: Change the oil more frequently when the operating conditions are extremely dusty or sandy.

Engine-Oil Specifications

Engine-Oil Type: Detergent oil (API service SF, SG, SH, SJ, or SL)

Crankcase Capacity: 1.7 L (58 oz) with the filter removed; 1.5 L (51 oz) without the filter removed

Viscosity: Refer to the table (Figure 24).

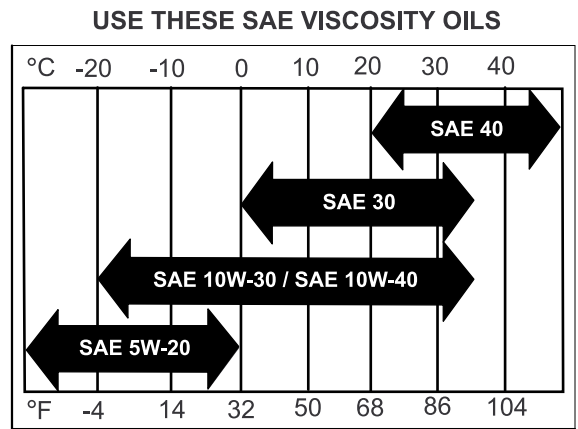

Figure 24

Checking the Engine-Oil Level

Service Interval: Before each use or daily—Check the engine-oil level.

1. Park the machine on a level surface, disengage the PTO, and engage the parking brake.
2. Shut off the engine, remove the key, and wait for all moving parts to stop before leaving the operating position.
3. Clean around the oil dipstick (Figure 25) so that dirt cannot fall into the filler hole and damage the engine.

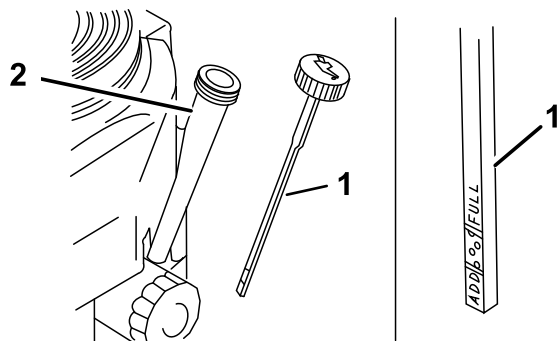

Figure 25

g306583

1. Oil dipstick
2. Filler tube

4. Unscrew the oil dipstick and wipe the end clean (Figure 25).
5. Slide the oil dipstick into the filler tube fully, but do not thread it onto the tube (Figure 25).
6. Pull the dipstick out and look at the end. If the oil level is low, slowly pour enough oil into the filler tube to raise the level to the Full mark.

Important: Do not overfill the crankcase with oil and run the engine, as this can damage the engine.

Changing the Engine Oil

Service Interval: After the first 8 hours—Change the engine oil.

Every 100 hours—Change the engine oil.

Every 200 hours—Change the engine-oil filter.

1. Start the engine and let it run for 5 minutes.
2. Park the machine so that the drain side is slightly lower than the opposite side, to ensure that the oil drains completely.
3. Disengage the PTO and engage the parking brake.
4. Shut off the engine, remove the key, and wait for all moving parts to stop before leaving the operating position.
5. Slide the drain hose over the oil-drain valve.
6. Place a drain pan below the drain hose.
7. Rotate the oil-drain valve to allow the oil to drain (Figure 26).
8. After the oil drains completely, close the drain valve.
9. Remove the drain hose (Figure 26).

Note: Dispose the used oil at a recycling center.

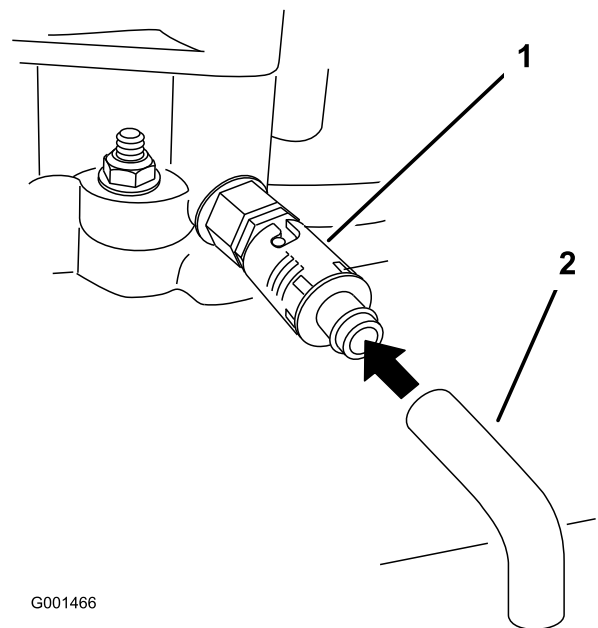

G001466

Figure 26

g001466

1. Oil-drain valve
2. Oil-drain hose

10. Slowly pour approximately 80% of the specified oil into the filler tube (Figure 25).
11. Check the engine-oil level.
12. Slowly add the additional oil to bring it to the Full mark.

Changing the Engine-Oil Filter

Note: Change the engine-oil filter more frequently when the operating conditions are extremely dusty or sandy.

1. Drain the oil from the engine.
2. Remove the old filter (Figure 27).

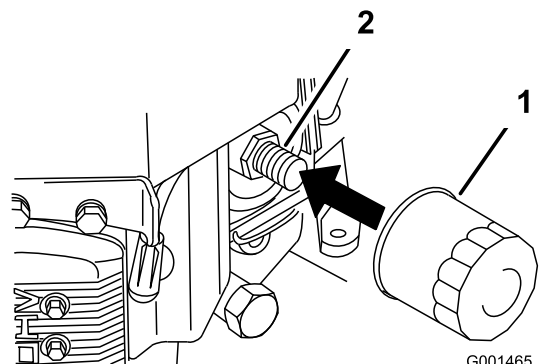

G001465

g001465

Figure 27

1. Engine-oil filter
2. Adapter

3. Apply a thin coat of new oil to the rubber gasket on the replacement filter (Figure 27).

4. Install the replacement oil filter to the filter adapter, turn the oil filter clockwise until the rubber gasket contacts the filter adapter, and tighten the filter an additional 3/4 turn (Figure 27).
5. Fill the crankcase with the proper type of new oil.
6. Run the engine for approximately 3 minutes, shut off the engine, and check for oil leaks around the oil filter and drain valve.
7. Check the engine-oil level and add oil, if needed.
8. Wipe up any spilled oil.

Servicing the Spark Plugs

Service Interval: Every 100 hours—Check the spark plugs.

Make sure that the air gap between the center and side electrodes is correct before installing the spark plug. Use a spark plug wrench for removing and installing the spark plug(s) and a gapping tool/feeler gauge to check and adjust the air gap. Install a new spark plug(s) if necessary.

Type: NGK® BPR4ES or equivalent

Air Gap: 0.75 mm (0.030 inch)

Removing the Spark Plugs

1. Disengage the PTO and engage the parking brake.
2. Shut off the engine, remove the key, and wait for all moving parts to stop before leaving the operating position.
3. Remove the spark plugs as shown in (Figure 28).

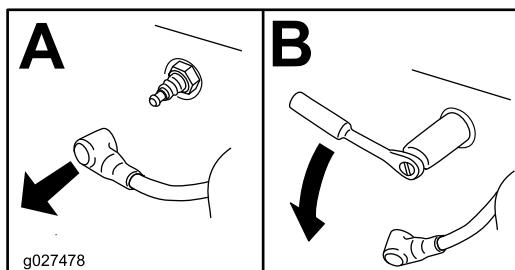

Figure 28

Checking the Spark Plugs

Important: Do not clean the spark plugs. Always replace the spark plugs when they have: a black coating, worn electrodes, an oily film, or cracks.

If you see light brown or gray on the insulator, the engine is operating properly. A black coating on the insulator usually means the air cleaner is dirty.

Set the gap to 0.75 mm (0.03 inch).

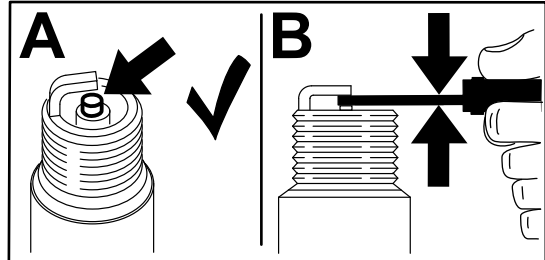

Figure 29

g206628

Installing the Spark Plugs

Tighten the spark plugs to 22 N·m (16 ft-lb).

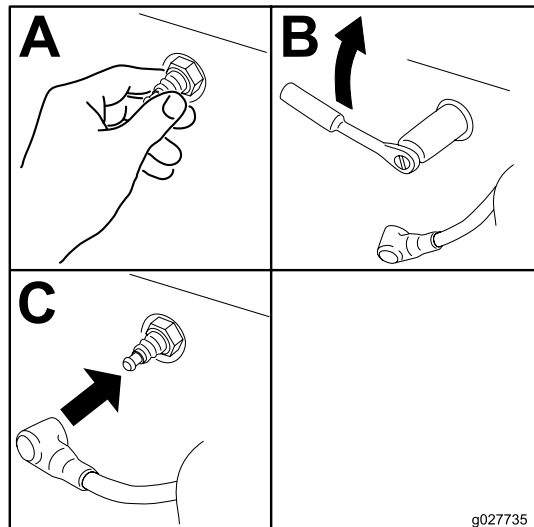

Figure 30

g027735

Fuel System Maintenance

⚠ DANGER

In certain conditions, fuel is extremely flammable and highly explosive. A fire or explosion from fuel can burn you and others and can damage property.

Refer to [Fuel Safety \(page 11\)](#) for a complete list of fuel related precautions.

Servicing the Fuel System

Draining the Fuel Tank

1. Park the machine on a level surface, disengage the PTO, and engage the parking brake.
2. Shut off the engine, remove the key, and wait for all moving parts to stop before leaving the operating position.
3. Close the fuel-shutoff valve at the fuel tank ([Figure 31](#)).
4. Squeeze the ends of the hose clamp and slide it up the fuel line away from the fuel filter ([Figure 31](#)).
5. Pull the fuel line off the fuel filter ([Figure 31](#)).
6. Open the fuel-shutoff valve and allow the fuel to drain into a fuel container or drain pan.
7. Install the fuel line to the fuel filter.

Note: Now is the best time to install a new fuel filter, because the fuel tank is empty; refer to [Replacing the Fuel Filter \(page 30\)](#).

Slide the hose clamp close to the valve to secure the fuel line.

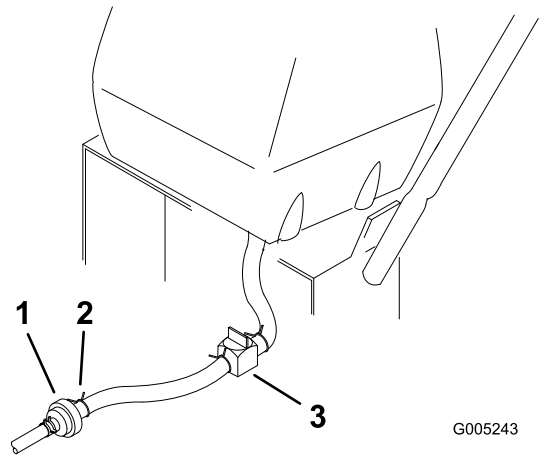

G005243

g005243

Figure 31

1. Fuel filter
2. Clamp
3. Fuel-shutoff valve

8. Wipe up any spilled fuel.

Replacing the Fuel Filter

Service Interval: Every 200 hours/Yearly (whichever comes first)

Important: Never install a dirty filter if it is removed from the fuel line.

1. Park the machine on a level surface, disengage the PTO, and engage the parking brake.
2. Shut off the engine, remove the key, and wait for all moving parts to stop before leaving the operating position.
3. Close the fuel-shutoff valve at the fuel tank ([Figure 31](#)).
4. Squeeze the ends of the hose clamps together and slide them away from the filter ([Figure 32](#)).

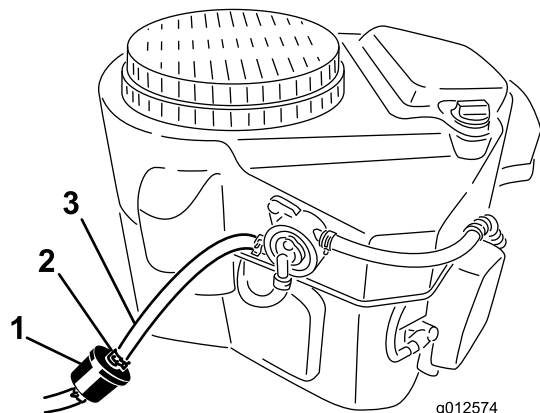

g012574

g012574

Figure 32

1. Fuel filter
2. Hose clamp
3. Fuel line

5. Remove the filter from the fuel lines.

6. Install a new filter and move the hose clamps close to the filter.
7. Open the fuel-shutoff valve at the fuel tank (Figure 31).
8. Check for fuel leaks and repair, if needed.
9. Wipe up any spilled fuel.

Servicing the Fuel-Vent System

Service Interval: Every 200 hours/Yearly (whichever comes first)

1. Park the machine on a level surface, disengage the PTO, and engage the parking brake.
2. Shut off the engine, remove the key, and wait for all moving parts to stop before leaving the operating position.
3. Remove the existing fuel-vent filter (Figure 33).
4. Install a new fuel-vent filter.

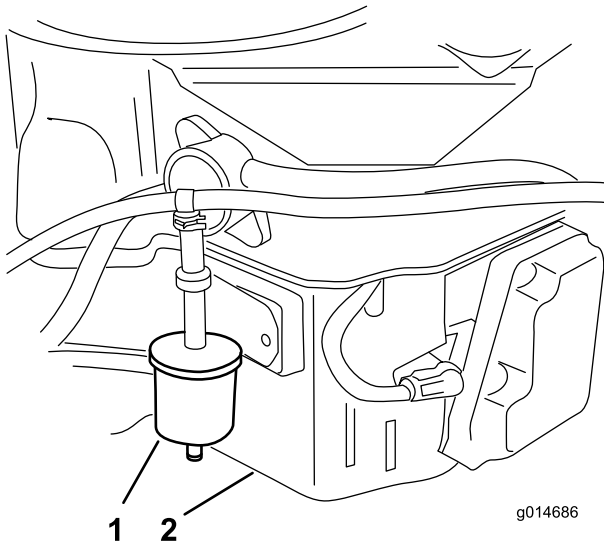

Figure 33

1. Fuel-vent filter
2. Right side of the engine

Drive System Maintenance

Checking the Tire Pressure

Service Interval: Every 50 hours/Monthly (whichever comes first)

Maintain the air pressure in the rear tires at 83 to 97 kPa (12 to 14 psi). Uneven tire pressure can cause an uneven cut (Figure 34).

Note: The front tires are semi-pneumatic tires and do not require air-pressure maintenance.

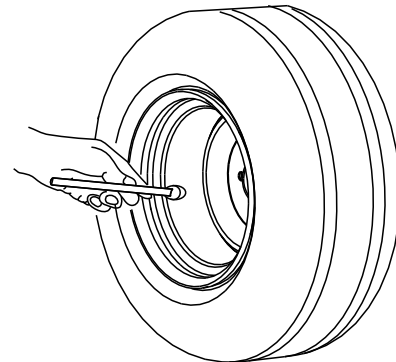

Figure 34

Cooling System Maintenance

Cleaning the Air-Intake Screen

Remove any buildup of grass, dirt, or other debris from the cylinder and cylinder head cooling fins, the air-intake screen on the flywheel end, and the carburetor-governor levers and linkage. This helps ensure adequate cooling and correct engine speed to reduce the possibility of overheating or mechanical damage to the engine.

Cleaning the Cooling System

Service Interval: Before each use or daily

Every 100 hours/Yearly (whichever comes first)

1. Park the machine on a level surface, disengage the PTO, and engage the parking brake.
2. Shut off the engine, remove the key, and wait for all moving parts to stop before leaving the operating position.
3. Remove the air-intake screen, recoil starter, and fan housing (Figure 35).
4. Clean the debris and grass from the engine parts.
5. Install the air-intake screen, recoil starter, and fan housing (Figure 35).

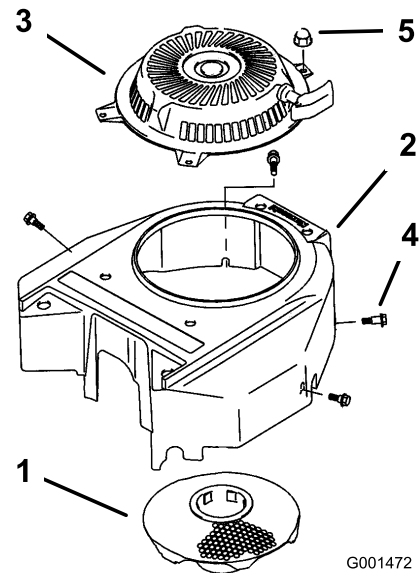

Figure 35

- | | |
|----------------------|---------|
| 1. Air-intake screen | 4. Bolt |
| 2. Fan housing | 5. Nut |
| 3. Recoil starter | |

g001472

Brake Maintenance

Servicing the Parking Brake

Check the brakes on both a level surface and a slope.

Always engage the parking brake when you stop the machine or leave it unattended. If the parking brake does not hold securely, adjust it.

Checking the Parking Brake

Service Interval: Before each use or daily

1. Park the machine on a level surface and disengage the PTO.
2. Shut off the engine, remove the key, and wait for all moving parts to stop before leaving the operating position.
3. Engage the parking brake.

Note: The wheels must lock when you try to push the machine forward.

4. If the wheels do not lock, adjust the brakes; refer to [Adjusting the Parking Brake \(page 33\)](#).
5. Disengage the brake and press upper control bar very lightly, approximately 13 mm (1/2 inch).

Note: The wheels should rotate freely. If not, refer to [Adjusting the Parking Brake \(page 33\)](#).

Adjusting the Parking Brake

The brake lever is on the upper control bar. If the parking brake does not hold securely, adjust it.

1. Park the machine on a level surface, disengage the PTO, and engage the parking brake.
2. Shut off the engine, remove the key, and wait for all moving parts to stop before leaving the operating position.

3. Check the brake before you adjust it; refer to [Checking the Parking Brake \(page 33\)](#).
4. Disengage the parking brake.
5. To adjust the brake, rotate the wing nuts on the brake rods ([Figure 36](#)).

Turn the wing nuts clockwise to tighten the brake and counterclockwise to loosen the brake.

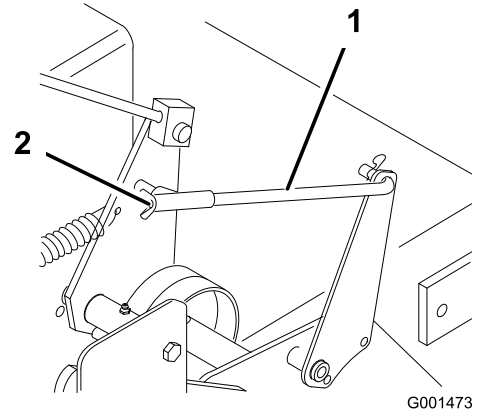

Figure 36

1. Brake rod
2. Wing nut

Note: The control bar should be parallel with the reference bar when properly adjusted.

6. Check the brake operation; refer to [Checking the Parking Brake \(page 33\)](#).

Important: With the parking brake disengaged, the rear wheels must rotate freely when you push the machine. If the brake action and the free-wheel rotation cannot be achieved, contact your Authorized Service Dealer immediately.

Belt Maintenance

Inspecting the Belts

Service Interval: Every 25 hours—Check the belts for wear or cracks.

Replace the belt if it is worn. The signs of a worn belt include squealing while the belt is rotating; the blades slipping while cutting grass; and frayed edges, burn marks, and cracks on the belt.

Replacing the Traction-Drive Belt

Service Interval: Every 50 hours/Monthly (whichever comes first)—Check the traction-drive belt.

1. Park the machine on a level surface, disengage the PTO, and engage the parking brake.
2. Shut off the engine, remove the key, and wait for all moving parts to stop before leaving the operating position.
3. Remove the hairpin cotter securing the brake rod to the brake arm to relax the tension on the belt idler (Figure 37).
4. Remove the bottom bolt and loosen the top bolt of the shield to rotate it for belt clearance (Figure 37).
5. Lift the belt past the idler and off the drive pulley (Figure 37).
6. Raise the wheel off the ground enough to remove the belt.
7. Replace the traction-drive belt.
8. Secure the shield with the previously removed bolt and tighten the bolts (Figure 37).
9. Secure the brake rod to the brake arm with the hairpin cotter (Figure 37).

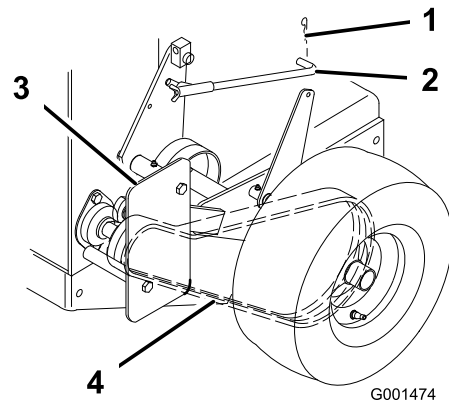

Figure 37

- | | |
|-------------------|---------------|
| 1. Hairpin cotter | 3. Shield |
| 2. Brake rod | 4. Drive belt |

g001474

Replacing the Drive Belt

1. Park the machine on a level surface, disengage the PTO, and engage the parking brake.
2. Shut off the engine, remove the key, and wait for all moving parts to stop before leaving the operating position.
3. Raise the rear of the machine and hold it up with jack stands.
4. Remove the mower belt (Figure 38).

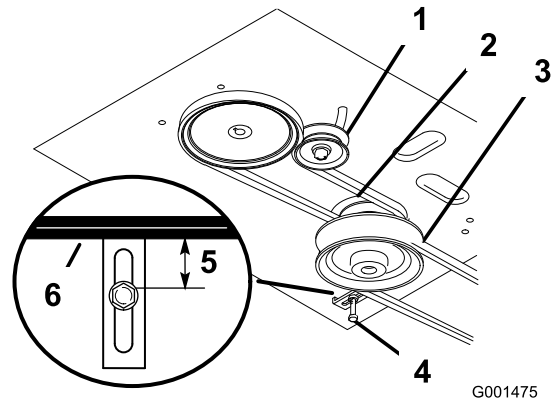

Figure 38

- | | |
|-----------------------------|---------------------|
| 1. Idler pulley in the slot | 4. Belt guide |
| 2. Traction belt | 5. 19 mm (3/4 inch) |
| 3. Mower belt | 6. Traction belt |

G001475

g001475

5. Loosen the pivot bolt enough to slide the idler pulley in the slot, and remove the traction belt from the engine and drive pulleys (Figure 38).
6. Install the new drive belt around the engine and drive pulleys (Figure 38).
7. Slide the idler pulley in the engine frame to tension the traction belt (Figure 38).

8. Install the mower belt (Figure 38).
9. Check the belt guide under the engine frame for the proper adjustment (Figure 38).

Note: The distance between the belt guide and mower belt should be 19 mm (3/4 inch) when you engage the mower belt. Adjust the belt, if necessary. The disengaged belt should not drag or fall off the pulley when the guides are properly adjusted.

Replacing the Mower Belt

Important: Adjust the brake whenever you adjust the belt tension or the brake linkage.

1. Park the machine on a level surface, disengage the PTO, and engage the parking brake.
2. Shut off the engine, remove the key, and wait for all moving parts to stop before leaving the operating position.
3. Remove the knobs and belt cover from the mower.
4. Remove the idler pulley and worn belt.
5. Install the new mower belt.
6. Install the idler pulley.
7. Engage the PTO and check the belt tension.

Note: The proper mower belt tension is 44 to 67 N·m (10 to 15 ft·lb) with the belt deflected 13 mm (1/2 inch) halfway between the pulleys (Figure 41).

8. Engage the PTO.
9. Check the clearance between the bell crank and transmission-output shaft (Figure 39).

Note: The clearance should be 2 to 3 mm (1/16 to 1/8 inch).

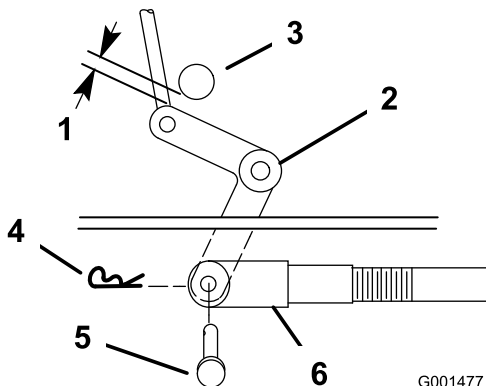

Figure 39

1. 2 to 3 mm (1/16 to 1/8 inch)
2. Bell crank
3. Transmission-output shaft
4. Hairpin cotter
5. Clevis pin
6. Clevis

10. Remove the hairpin cotter and clevis pin from the bell crank (Figure 39).
11. Rotate the clevis clockwise on the rod to increase the clearance; rotate it counterclockwise to decrease it (Figure 39).
12. Disengage the PTO.

Note: If the assist arm does not contact the front stop on the mower deck (Figure 40), adjust the clevis to bring the bell crank closer to the transmission-output shaft (Figure 39).

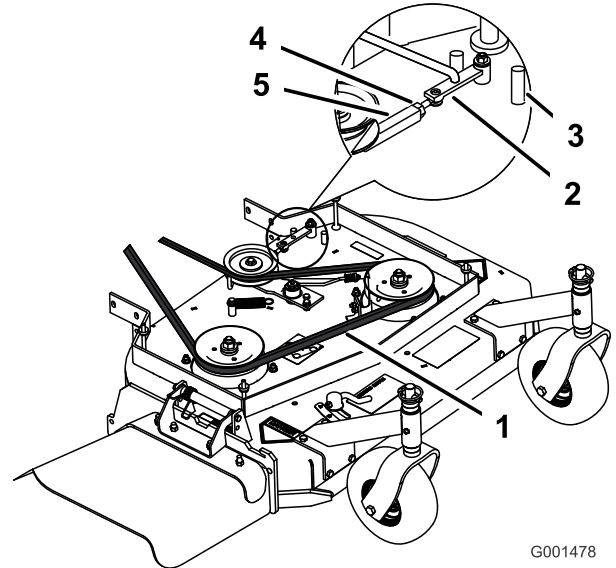

Figure 40

1. 13 mm (1/2 inch) deflection here
2. Assist arm
3. Front stop
4. Locknut
5. Turnbuckle

13. Check the belt guide under the engine frame for the proper adjustment (Figure 38).

Note: The distance between the belt guide and mower belt should be 32 mm (1-1/4 inches) when you engage the mower belt. Adjust the mower belt as necessary. The disengaged belt should not drag or fall off the pulley when the guides are properly adjusted.

Adjusting the Mower Belt Tension

Service Interval: After the first 8 hours—Check the mower belt tension.

After the first 25 hours—Check the mower belt tension.

Every 50 hours—Check the mower belt tension.

Important: Adjust the brake whenever you adjust the belt tension or brake linkage.

Important: The belt must be tight enough to not slip during heavy loads, while cutting grass. Over-tensioning the belt reduces the life of the spindle bearing, belt, and idler pulley.

1. Park the machine on a level surface, disengage the PTO, and engage the parking brake.
2. Shut off the engine, remove the key, and wait for all moving parts to stop before leaving the operating position.
3. Loosen the locknut on the turnbuckle (Figure 41).
4. Adjust the tension of the belt.
 - Rotate the turnbuckle toward the rear of the machine to increase the tension on the belt.
 - Rotate the turnbuckle toward the front of the machine to decrease the tension on the belt (Figure 41).

Note: The eyebolt threads on both ends of the turnbuckle should be engaged a minimum of 8 mm (5/16 inch).

5. Engage the PTO and check the belt tension. Adjust the tension until it is correct.

Note: The proper mower belt tension is 44 to 67 N·m (10 to 15 ft-lb) with the belt deflected 13 mm (1/2 inch) halfway between the pulleys (Figure 41).

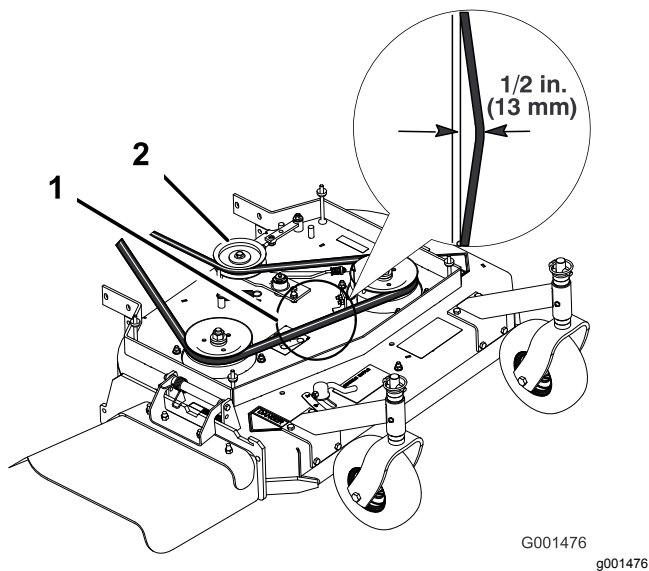

Figure 41

1. Mower belt with 13 mm (1/2 inch) deflection
2. Idler pulley

6. Tighten the locknut on the turnbuckle.
7. Check the blade-brake adjustment; refer to [Adjusting the Blade Brake](#) (page 40).

Adjusting the PTO-Engagement Linkage

The adjustment for the PTO-engagement linkage is located beneath the front, left corner of the engine deck.

1. Park the machine on a level surface, disengage the PTO, and engage the parking brake.
2. Shut off the engine, remove the key, and wait for all moving parts to stop before leaving the operating position.
3. Engage PTO.
4. Adjust the linkage length to where the lower end of the bellcrank just clears the axle-support gusset (Figure 42).

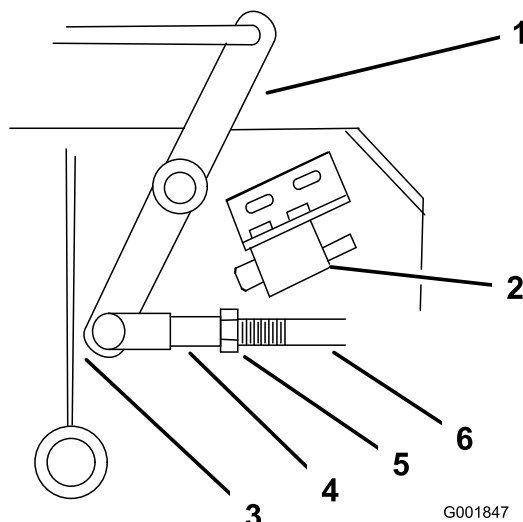

Figure 42

1. Bellcrank
2. Safety switch located under the engine deck
3. Bellcrank just clears the gusset with the PTO engaged
4. Yoke
5. Nut
6. Assist-arm link

5. Ensure that the assist arm is against the rear assist-arm stop on the deck (Figure 43).
6. Disengage the PTO.
7. The assist arm should contact the front assist-arm stop on the deck. If it does not contact, adjust the bellcrank so that it is closer to the gusset (Figure 43).

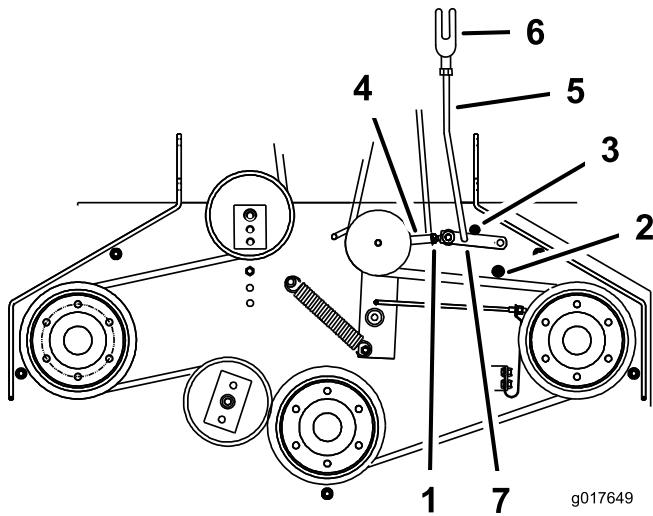

Figure 43

- | | |
|--------------------------|--------------------|
| 1. Yoke | 5. Assist-arm link |
| 2. Nut | 6. Assist arm |
| 3. Rear assist-arm stop | 7. Turnbuckle |
| 4. Front assist-arm stop | |

Adjusting the PTO-Safety Switch

1. Park the machine on a level surface, disengage the PTO, and engage the parking brake.
2. Shut off the engine, remove the key, and wait for all moving parts to stop before leaving the operating position.
3. Ensure that the assist arm is against the front assist-arm stop.
4. If needed, adjust the PTO-safety switch by loosening the bolts securing the switch bracket (Figure 44).
5. Move the mounting bracket until the bellcrank presses the plunger by 6 mm (1/4 inch).

Important: Ensure that the bellcrank does not touch the switch body; otherwise, damage to the switch could occur (Figure 44).

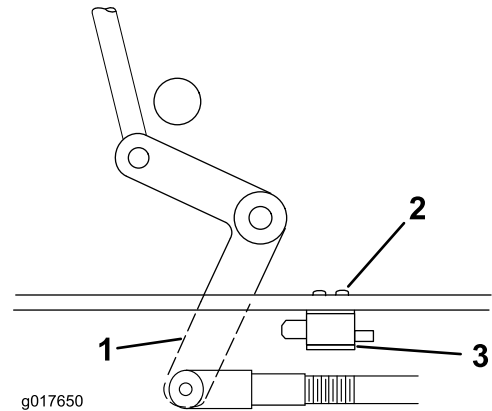

Figure 44

- | | |
|-------------------|----------------------------|
| 1. Bellcrank | 3. Switch-mounting bracket |
| 2. Bolts and nuts | |

6. Tighten the switch-mounting bracket.

Mower Deck Maintenance

Blade Safety

A worn or damaged blade can break and a piece could be thrown toward you or bystanders, resulting in serious personal injury or death.

- Inspect the blades periodically for excessive wear or damage.
- Use care when checking the blades. Wear gloves and use caution when servicing them. Only replace the blades; never straighten or weld them.
- On multi-bladed machines, take care as rotating 1 blade can cause other blades to rotate.

Servicing the Cutting Blades

To ensure a superior quality of cut, keep the blades sharp. For convenient sharpening and replacement, you may want to keep extra blades on hand.

Before Inspecting or Servicing the Blades

1. Park the machine on a level surface, disengage the PTO, and engage the parking brake.
2. Shut off the engine, remove the key, and disconnect the spark-plug wires from the spark plugs.

Inspecting the Blades

Service Interval: Before each use or daily

1. Inspect the cutting edges (Figure 45).
2. If the edges are not sharp or have nicks, remove and sharpen the blade; refer to [Sharpening the Blades](#) (page 39).
3. Inspect the blades, especially in the curved area.
4. If you notice any cracks, wear, or a slot forming in this area, immediately install a new blade (Figure 45).

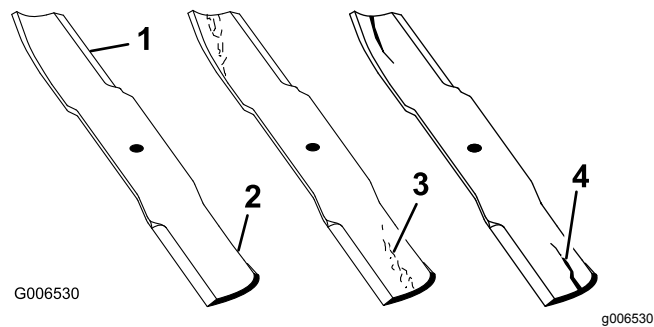

Figure 45

1. Cutting edge
2. Curved area
3. Wear/slot forming
4. Crack

Checking for Bent Blades

1. Rotate the blades until the ends face forward and backward.
2. Measure from a level surface to the cutting edge, position A, of the blades (Figure 46).

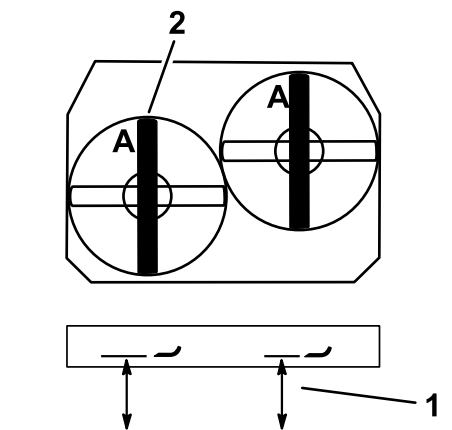

Figure 46

1. Measure here from blade to hard surface
2. Position A

3. Rotate the opposite ends of the blades forward.
4. Measure from a level surface to the cutting edge of the blades at the same position as in step 2 above.

Note: The difference between the dimensions obtained in steps 2 and 3 must not exceed 3 mm (1/8 inch).

Note: If this dimension exceeds 3 mm (1/8 inch), replace the blade.

⚠ WARNING

A blade that is bent or damaged could break apart and could critically injure you or bystanders.

- Always replace a bent or damaged blade with a new blade.
- Do not file or create sharp notches in the edges or surfaces of the blade.

Removing the Blades

Replace the blades if you hit a solid object or if the blades are out of balance or bent. To ensure optimum performance and continued safety conformance of the machine, use genuine Toro replacement blades. Replacement blades made by other manufacturers may result in non-conformance with safety standards.

1. Hold the blade bolt with a wrench.
2. Remove the nut, blade bolt, curved washer, blade, spacers, and thin washer from the spindle (Figure 47).

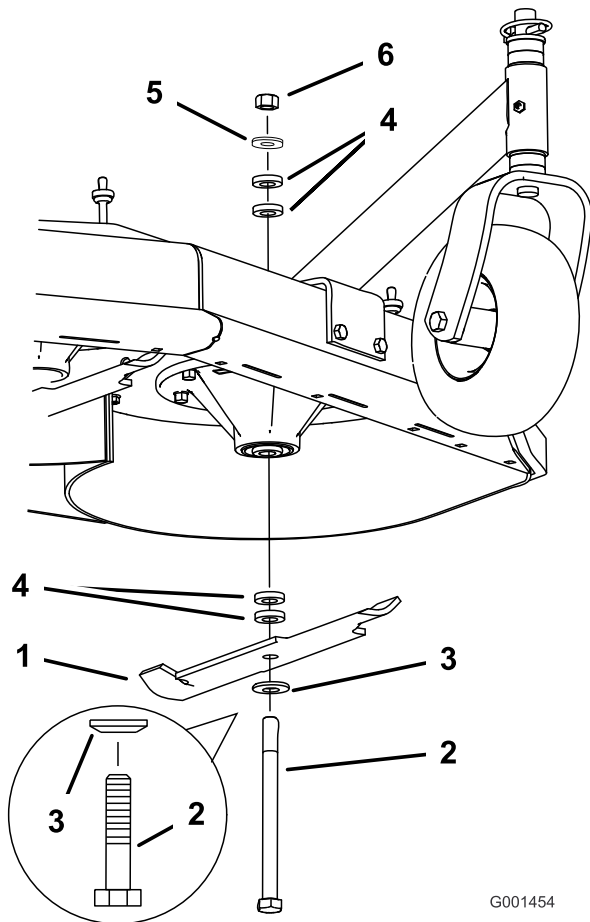

Figure 47

- | | |
|------------------|----------------|
| 1. Blade | 4. Spacer |
| 2. Blade bolt | 5. Thin washer |
| 3. Curved washer | 6. Nut |

Sharpening the Blades

1. Use a file to sharpen the cutting edge at both ends of the blade (Figure 48).

Note: Maintain the original angle.

Note: The blade retains its balance if the same amount of material is removed from both cutting edges.

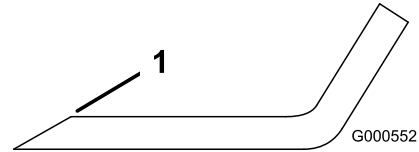

Figure 48

1. Sharpen at original angle.

2. Check the balance of the blade by putting it on a blade balancer (Figure 49).

Note: If the blade stays in a horizontal position, the blade is balanced and can be used.

Note: If the blade is not balanced, file some metal off the end of the sail area only (Figure 48).

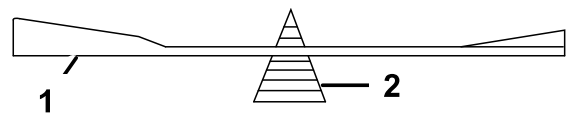

Figure 49

- | | |
|----------|-------------|
| 1. Blade | 2. Balancer |
|----------|-------------|

3. Repeat this procedure until the blade is balanced.

Installing the Blades

1. Install the curved washer and then the blade onto the bolt. Select the proper number of spacer(s) for the height of cut, and slide the bolt into the spindle (Figure 47).

Important: The curved part of the blade must point upward toward the inside of the mower to ensure proper cutting.

2. Install the remaining spacer(s) and secure them with a thin washer and a nut (Figure 47).
3. Torque the blade bolt to 101 to 108 N·m (75 to 80 ft·lb).

Adjusting the Blade Brake

1. Park the machine on a level surface, disengage the PTO, and engage the parking brake.
2. Shut off the engine, remove the key, and disconnect the spark-plug wires from the spark plugs.
3. If necessary, adjust the spring-mounting bolts so that the blade-brake pad rubs against both sides of the pulley groove (Figure 50).
4. Adjust the nut at the end of the blade brake rod until there is 3 mm to 5 mm (1/8 to 3/16 inch) between the nut and spacer (Figure 50).
5. Engage the blades.

Note: Ensure that the blade-brake pad no longer contacts the pulley groove.

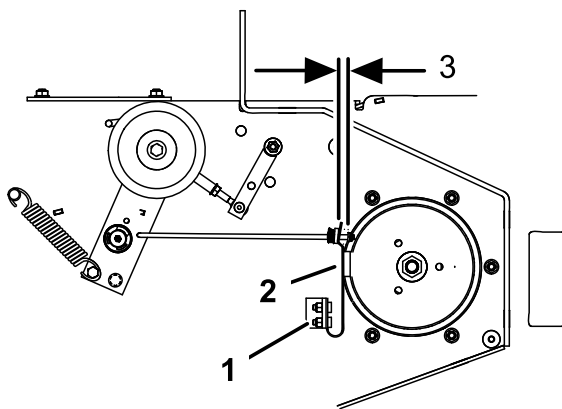

G001485

g001485

Figure 50

- | | |
|--------------------------|------------------------------------|
| 1. Spring-mounting bolts | 3. 3 mm to 5 mm (1/8 to 3/16 inch) |
| 2. Blade-brake pad | |

Replacing the Grass Deflector

⚠ WARNING

An uncovered discharge opening could allow the machine to throw objects toward you or bystanders, resulting in serious injury. Also, contact with the blade could occur.

Never operate the machine without the grass deflector, the discharge cover, or the grass-collection system in place.

1. Park the machine on a level surface, disengage the PTO, and engage the parking brake.
2. Shut off the engine, remove the key, and disconnect the spark-plug wires from the spark plugs.
3. Remove the locknut, bolt, spring and spacer securing the deflector to the pivot brackets (Figure 51).

Note: Remove the damaged or worn grass deflector.

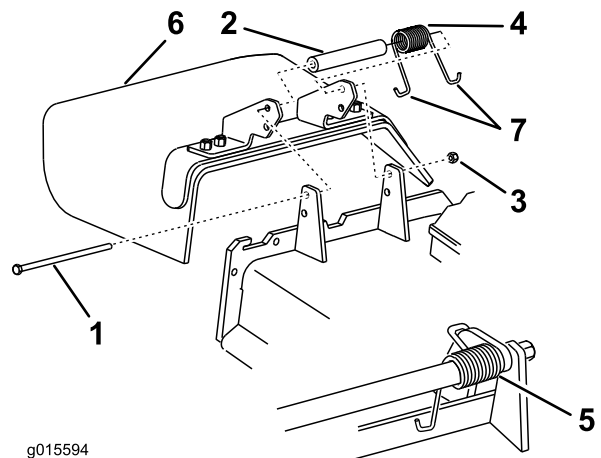

g015594

g015594

Figure 51

- | | |
|------------|-----------------------------|
| 1. Bolt | 5. Spring (installed) |
| 2. Spacer | 6. Grass deflector |
| 3. Locknut | 7. J-hook end of the spring |
| 4. Spring | |

4. Place the spacer and spring onto the grass deflector.
5. Place one J-hook end of the spring behind the deck edge (Figure 51).

Note: Ensure that one J-hook end of the spring is installed behind the deck edge before installing the bolt as shown in Figure 51.

6. Install the bolt and nut.

7. Place one J-hook end of the spring around the grass deflector (Figure 51).

Important: The grass deflector must be able to rotate. Lift the deflector up to the fully-open position and ensure that it rotates into the fully-down position.

Cleaning

Cleaning under the Mower

Service Interval: Before each use or daily

Remove the grass buildup under the mower daily.

1. Park the machine on a level surface, disengage the PTO, and engage the parking brake.
2. Shut off the engine, remove the key, and disconnect the spark-plug wires from the spark plugs.
3. Raise the front of the machine using a jack and use jack stands to support the machine.
4. Clean the machine with a rag. Do not spray the machine.

Disposing of Waste

Engine oil, batteries, hydraulic fluid, and engine coolant are pollutants to the environment. Dispose of these according to your state and local regulations.

Storage

Cleaning and Storing the Machine

1. Park the machine on a level surface, disengage the PTO, and engage the parking brake.
2. Shut off the engine, remove the key, and wait for all moving parts to stop before leaving the operating position.
3. Remove grass clippings, dirt, and grime from the external parts of the entire machine, especially the engine and hydraulic system.

Important: You can wash the machine with mild detergent and water. Do not pressure-wash the machine. Avoid excessive use of water, especially near the control panel, engine, hydraulic pumps, and motors.

4. Check the parking brake operation; refer to [Operating the Parking Brake \(page 14\)](#).
5. Service the air cleaner; refer to [Servicing the Air Cleaner \(page 26\)](#).
6. Grease the machine; refer to [Lubrication \(page 25\)](#).
7. Change the crankcase oil; refer to [Changing the Engine Oil \(page 28\)](#).
8. Check the tire pressure; refer to [Checking the Tire Pressure \(page 31\)](#).
9. Scrape any heavy buildup of grass and dirt from the underside of the mower, then wash the machine with a garden hose.

Note: Run the machine with the blade-control switch (PTO) engaged and the engine at high idle for 2 to 5 minutes after washing.

10. Check the condition of the blades; refer to [Servicing the Cutting Blades \(page 38\)](#).
11. Prepare the machine for storage for over 30 days as follows:
 - A. Add fuel stabilizer/conditioner to fresh fuel in the tank. Follow mixing instructions from the fuel stabilizer manufacturer. Do not use an alcohol-based stabilizer (ethanol or methanol).
 - B. Run the engine to distribute conditioned fuel through the fuel system for 5 minutes.
 - C. Shut off the engine, allow it to cool, and drain the fuel tank.
 - D. Start the engine and run it until it shuts off.

- E. Dispose of fuel properly. Recycle the fuel according to local codes.

Important: Do not store fuel containing stabilizer/conditioner longer than the duration recommended by the fuel-stabilizer manufacturer.

12. Remove and check the condition of the spark plug(s); refer to [Servicing the Spark Plugs \(page 29\)](#). With the spark plug(s) removed from the engine, pour 30 ml (2 tablespoons) of engine oil into the spark plug hole. Use the starter to crank the engine and distribute the oil inside the cylinder. Install the spark plug(s). Do not install the wire on the spark plug(s).
13. Check and tighten all fasteners. Repair or replace any part that is damaged.
14. Paint all scratched or bare metal surfaces. Paint is available from your Authorized Service Dealer.
15. Store the machine in a clean, dry garage or storage area. Remove the key from the switch and keep it out of reach of children or other unauthorized users. Cover the machine to protect it and keep it clean.

Troubleshooting

Problem	Possible Cause	Corrective Action
The fuel tank is showing signs of collapsing or the machine is frequently showing signs of running out of fuel.	1. The air-cleaner paper element clogged.	1. Clean the paper element.
The engine overheats.	1. The engine load is excessive. 2. The oil level in the crankcase is low. 3. The cooling fins and air passages under the engine-blower housing are plugged. 4. The air cleaner is dirty. 5. Dirt, water, or stale fuel is in the fuel system.	1. Reduce the ground speed. 2. Add oil to the crankcase. 3. Remove the obstruction from the cooling fins and air passages. 4. Clean or replace the air-cleaner element. 5. Contact an Authorized Service Dealer
The starter does not crank.	1. The PTO is engaged. 2. The electrical connections are corroded or loose. 3. A relay or switch is damaged.	1. Disengage the PTO. 2. Check the electrical connections for good contact. 3. Contact an Authorized Service Dealer.
The engine does not start, starts hard, or fails to keep running.	1. The fuel tank is empty. 2. The choke (if applicable) is not on. 3. The air cleaner is dirty. 4. The spark-plug wire(s) is loose or disconnected. 5. The spark plug(s) is pitted, fouled, or the gap is incorrect. 6. There is dirt in fuel filter. 7. Dirt, water, or stale fuel is in fuel system. 8. There is incorrect fuel in the fuel tank. 9. The oil level in the crankcase is low.	1. Fill the fuel tank. 2. Move the choke lever to the ON position. 3. Clean or replace the air-cleaner element. 4. Install the wire(s) on the spark plug. 5. Install a new, correctly gapped spark plug(s). 6. Replace the fuel filter. 7. Contact an Authorized Service Dealer. 8. Drain the tank and replace the fuel with the proper type. 9. Add oil to the crankcase.
The engine loses power.	1. The engine load is excessive. 2. The air cleaner is dirty. 3. The oil level in the crankcase is low. 4. The cooling fins and air passages under the engine blower housing are plugged. 5. The spark plug(s) is pitted, fouled, or the gap is incorrect. 6. The fuel-tank vent is blocked. 7. There is dirt in the fuel filter. 8. Dirt, water, or stale fuel is in the fuel system. 9. There is incorrect fuel in the fuel tank.	1. Reduce the ground speed. 2. Clean the air-cleaner element. 3. Add oil to the crankcase. 4. Remove the obstruction from the cooling fins and air passages. 5. Install a new, correctly gapped spark plug(s). 6. Contact an Authorized Service Dealer. 7. Replace the fuel filter. 8. Contact an Authorized Service Dealer. 9. Drain the tank and replace the fuel with the proper type.
The machine does not drive.	1. The shift lever is in the NEUTRAL position. 2. The traction belts are worn, loose, or broken. 3. The traction belt is off a pulley. 4. The idler spring is broken or missing.	1. Move the shift lever to a drive gear position. 2. Contact an Authorized Service Dealer. 3. Contact an Authorized Service Dealer. 4. Contact an Authorized Service Dealer.

Problem	Possible Cause	Corrective Action
The machine vibrates abnormally.	<ol style="list-style-type: none"> 1. The cutting blade(s) is/are bent or unbalanced. 2. The blade mounting bolt is loose. 3. The engine mounting bolts are loose. 4. The engine pulley, idler pulley, or blade pulley is loose. 5. The engine pulley is damaged. 6. The blade spindle is bent. 7. The motor mount is loose or worn. 	<ol style="list-style-type: none"> 1. Install new cutting blade(s). 2. Tighten the blade mounting bolt. 3. Tighten the engine mounting bolts. 4. Tighten the appropriate pulley. 5. Contact an Authorized Service Dealer. 6. Contact an Authorized Service Dealer. 7. Contact an Authorized Service Dealer.
The cutting height is uneven.	<ol style="list-style-type: none"> 1. The blade(s) is not sharp. 2. A cutting blade(s) is/are bent. 3. The mower is not level. 4. The underside of the mower deck is dirty. 5. The tire pressure is incorrect. 6. A blade spindle is bent. 	<ol style="list-style-type: none"> 1. Sharpen the blade(s). 2. Install a new cutting blade(s). 3. Level the mower from side-to-side and front-to-rear. 4. Clean the underside of the mower deck. 5. Adjust the tire pressure. 6. Contact an Authorized Service Dealer.
The blades do not rotate.	<ol style="list-style-type: none"> 1. The drive belt is worn, loose or broken. 2. The drive belt is off of the pulley. 3. The power-takeoff (PTO) switch or PTO clutch is faulty. 4. The mower belt is worn, loose, or broken. 	<ol style="list-style-type: none"> 1. Install a new drive belt. 2. Install the drive belt and check the adjusting shafts and belt guides for the correct position. 3. Contact an Authorized Service Dealer. 4. Install a new mower belt.

Schematics

KAWASAKI TWIN

WIRE COLOR CODES

BLK	BLACK	W	WHITE
BU	BLUE		

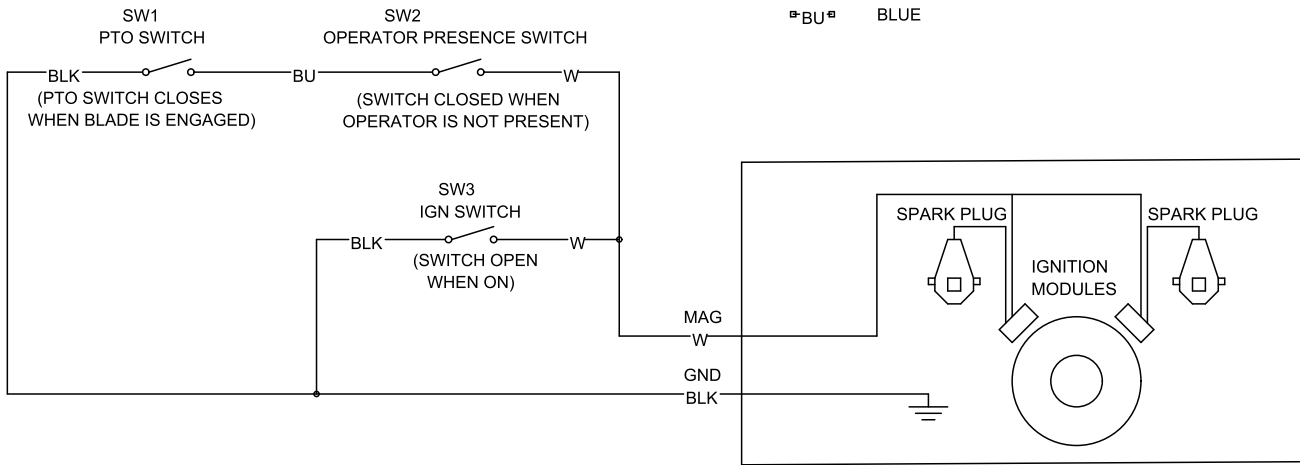

G001471

g001471

Electrical Schematic (Rev. -A)

Notes:

Notes:

California Proposition 65 Warning Information

What is this warning?

You may see a product for sale that has a warning label like the following:



WARNING: Cancer and Reproductive Harm—www.p65Warnings.ca.gov.

What is Prop 65?

Prop 65 applies to any company operating in California, selling products in California, or manufacturing products that may be sold in or brought into California. It mandates that the Governor of California maintain and publish a list of chemicals known to cause cancer, birth defects, and/or other reproductive harm. The list, which is updated annually, includes hundreds of chemicals found in many everyday items. The purpose of Prop 65 is to inform the public about exposure to these chemicals.

Prop 65 does not ban the sale of products containing these chemicals but instead requires warnings on any product, product packaging, or literature with the product. Moreover, a Prop 65 warning does not mean that a product is in violation of any product safety standards or requirements. In fact, the California government has clarified that a Prop 65 warning "is not the same as a regulatory decision that a product is 'safe' or 'unsafe.'" Many of these chemicals have been used in everyday products for years without documented harm. For more information, go to <https://oag.ca.gov/prop65/faqs-view-all>.

A Prop 65 warning means that a company has either (1) evaluated the exposure and has concluded that it exceeds the "no significant risk level"; or (2) has chosen to provide a warning based on its understanding about the presence of a listed chemical without attempting to evaluate the exposure.

Does this law apply everywhere?

Prop 65 warnings are required under California law only. These warnings are seen throughout California in a wide range of settings, including but not limited to restaurants, grocery stores, hotels, schools, and hospitals, and on a wide variety of products. Additionally, some online and mail order retailers provide Prop 65 warnings on their websites or in catalogs.

How do the California warnings compare to federal limits?

Prop 65 standards are often more stringent than federal and international standards. There are various substances that require a Prop 65 warning at levels that are far lower than federal action limits. For example, the Prop 65 standard for warnings for lead is 0.5 µg/day, which is well below the federal and international standards.

Why don't all similar products carry the warning?

- Products sold in California require Prop 65 labelling while similar products sold elsewhere do not.
- A company involved in a Prop 65 lawsuit reaching a settlement may be required to use Prop 65 warnings for its products, but other companies making similar products may have no such requirement.
- The enforcement of Prop 65 is inconsistent.
- Companies may elect not to provide warnings because they conclude that they are not required to do so under Prop 65; a lack of warnings for a product does not mean that the product is free of listed chemicals at similar levels.

Why does Toro include this warning?

Toro has chosen to provide consumers with as much information as possible so that they can make informed decisions about the products they buy and use. Toro provides warnings in certain cases based on its knowledge of the presence of one or more listed chemicals without evaluating the level of exposure, as not all the listed chemicals provide exposure limit requirements. While the exposure from Toro products may be negligible or well within the "no significant risk" range, out of an abundance of caution, Toro has elected to provide the Prop 65 warnings. Moreover, if Toro does not provide these warnings, it could be sued by the State of California or by private parties seeking to enforce Prop 65 and subject to substantial penalties.