



Count on it.

Parts Catalog

Stand-On E-Spreader/Sprayer

Model No. 34230—Serial No. 40000000 and Up



Ordering Replacement Parts

To order replacement parts, please supply the part number, the quantity, and the description of each part desired.

Understanding Reference Numbers

Each identified part in an illustration has a reference number. The reference number for a part also appears in the parts list, along with other information about the part.

This catalog uses two special reference number formats, one to indicate parts in a service assembly and another to indicate the quantity of a given part in an illustration.

Service Assembly Reference Numbers

Parts in service assemblies have reference numbers in the form a:b. The a represents the reference number of the entire service assembly and the b represents a sequential number unique to each part within the service assembly.

For example, a wheel assembly might be identified by reference number 6, the tire by 6:1, the valve by 6:2, and the wheel by 6:3. When you order the assembly identified by reference number 6, you receive all parts identified by reference numbers 6:1, 6:2, and 6:3. However, you may also order any part individually. Reference numbers of this type appear in illustration and in parts lists.

Reference Numbers Indicating Quantity

In an illustration, if a reference number indicates more than one part, the reference number has the form nX y. The n represents the quantity of the part, the X is the multiplication symbol, and the y represents the reference number.

For example, in an illustration, the reference number 2X 37 means that two of the parts identified by reference number 37 are indicated.

Contents

Frame Assembly.....	4
Knee Pad Assembly.....	6
Steering Assembly.....	8
Steering Linkage Assembly No. 126-7185.....	10
Ground Drive Assembly.....	12
Transaxle Cover Assembly No. 126-1462.....	14
Engine Assembly.....	16
Electrical Assembly.....	18
Spray System Assembly.....	20
Sprayer Tank Assembly No. 126-0286.....	22
Strainer Assembly No. 126-4358.....	24
Control Valve Manifold and Hose Assembly.....	26
Control Valve Manifold Assembly No. 135-6362.....	28
Left Nozzle Assembly No. 126-3667.....	30
Right Nozzle Assembly No. 126-3669.....	32
Center Nozzle Assembly No. 126-3668.....	34
Spreader Assembly.....	36
Spreader Hopper Assembly.....	38
Side Deflector Assembly.....	40

Frame Assembly

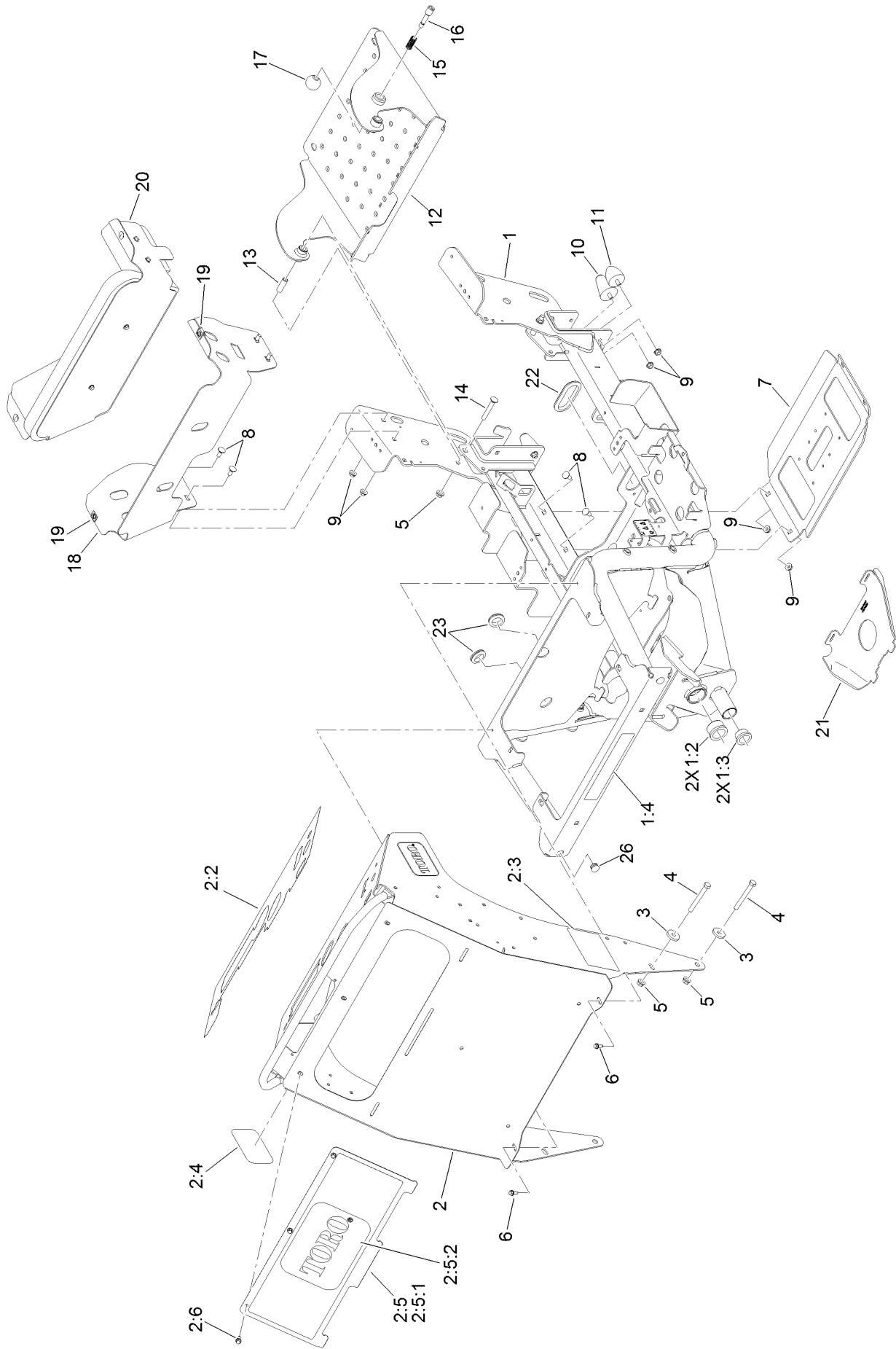

Frame Assembly (continued)

<i>Ref.</i>	<i>Part Number</i>	<i>Qty.</i>	<i>Description</i>	<i>Ref.</i>	<i>Part Number</i>	<i>Qty.</i>	<i>Description</i>
1	142-2788	1	Frame ASM	8	126-0695	8	Screw-CARR
1:2	126-3008	2	Bearing-Flanged	9	135-2881	12	Nut-HF
1:3	126-3002	2	Bearing-Flanged	10	114-1925	2	Bumper-Rubber
1:4	126-4994	1	Decal-Down, Tie	11	114-1926	2	Bumper-Rubber
2	142-2217	1	Control Tower ASM	12	126-0435	1	Operator Platform ASM
2:2	135-7247	1	Decal-Control	13	126-0434	2	Bushing-Pivot, Platform
2:3	126-5186	1	Decal-Service Aid	14	126-0702	2	Screw-CARR
2:4	126-5060	2	Decal-Logo, Toro	15	114-5348	1	Spring
2:5	126-7216	1	Access Panel W/ Decal	16	119-8650	1	Pin-Latch
2:5:1	126-6402-01	1	Panel-Access	17	1-603175	1	Knob-Ball
2:5:2	126-7225	1	Decal-Toro	18	126-1234-03	1	Mount-Pad, Knee
2:6	32144-10	3	Screw-HWH	19	119-1730	2	Receptacle-Clip, Mini
3	126-3875	4	Washer	20		1	Knee Pad ASM ●
4	126-2661	4	Screw-HH	21	126-2567	1	Shield-Dust
5	135-2882	6	Nut-HF	22	237-164	2	Grommet
6	32144-10	2	Screw-HWH	23	240-5	2	Grommet
7	126-1415	1	Guard-Lower	26	126-5147	2	Plug-Tube

● Not serviced separately

Knee Pad Assembly

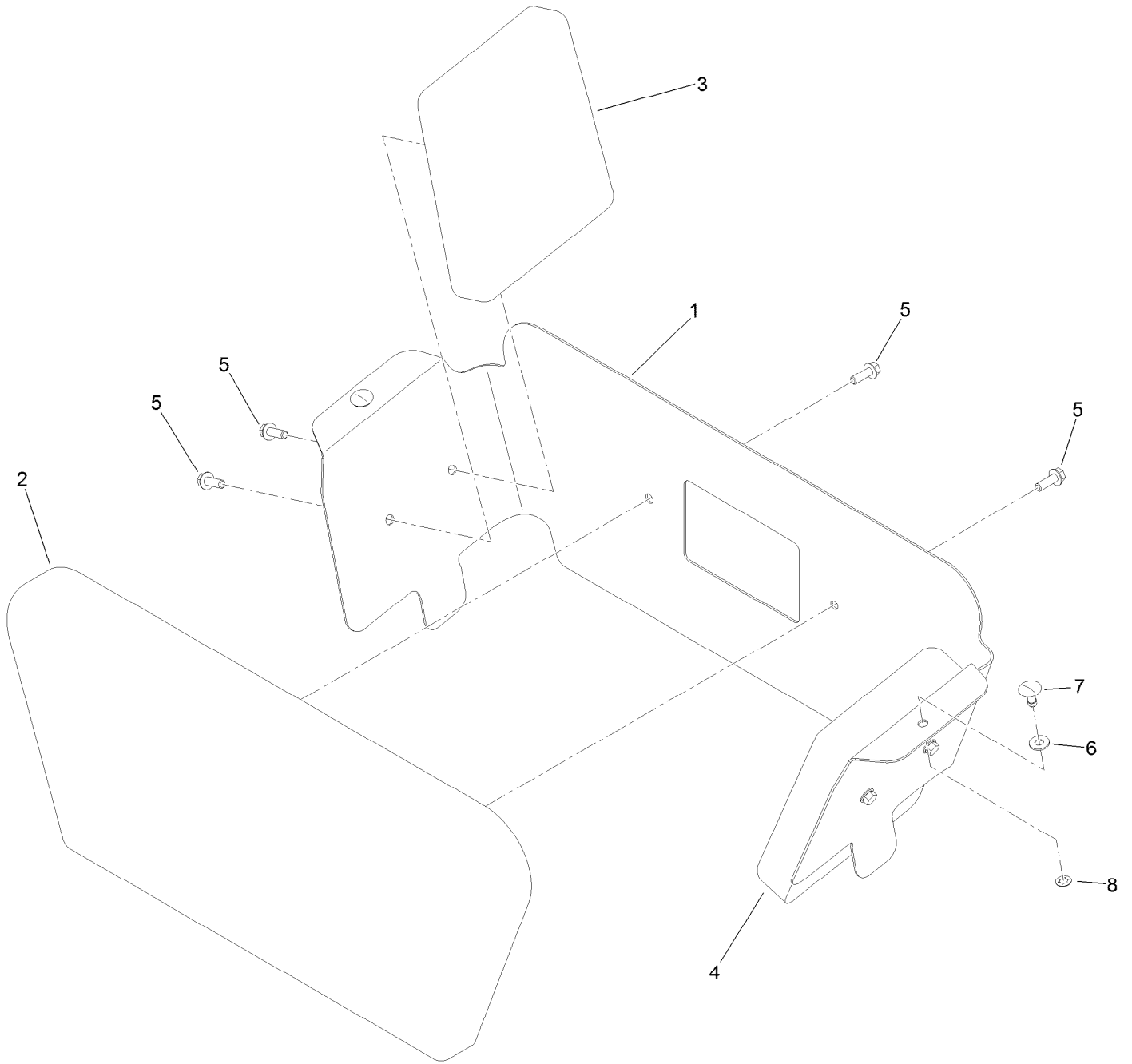

Knee Pad Assembly (continued)

<i>Ref.</i>	<i>Part Number</i>	<i>Qty.</i>	<i>Description</i>	<i>Ref.</i>	<i>Part Number</i>	<i>Qty.</i>	<i>Description</i>
1	126-1244-03	1	Bracket-Pad, Knee	5	117-8304	6	Screw-HHF
2	142-2754	1	Pad-Knee, Center	6	360-0140	2	Washer-Flat
3	126-2780	1	Pad-Knee, Side (LH)	7	119-1728	2	Stud-1/4 Turn
4	126-2781	1	Pad-Knee, Side (RH)	8	119-1729	2	Retainer-Stud

Steering Assembly

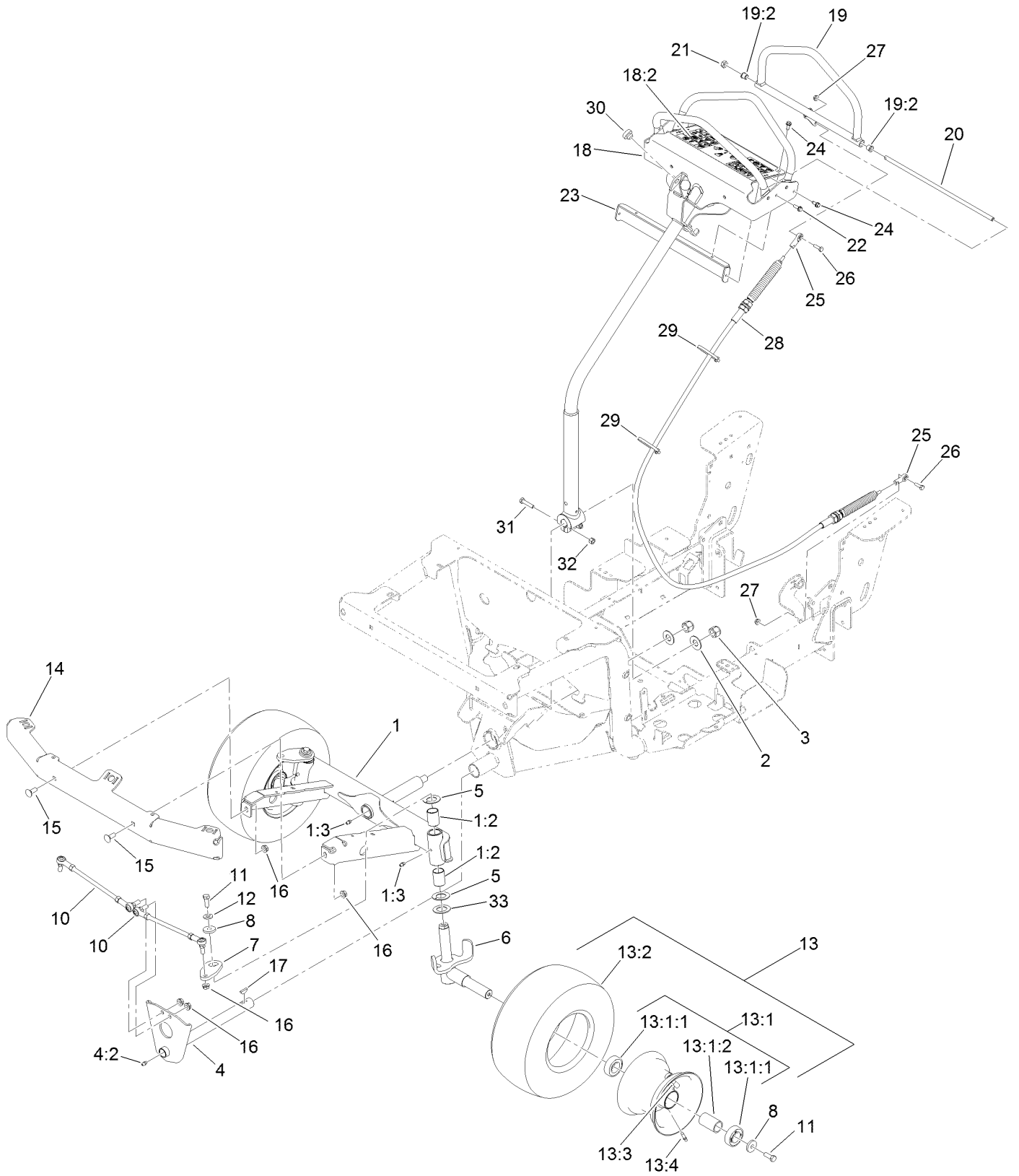

Steering Assembly (continued)

<i>Ref.</i>	<i>Part Number</i>	<i>Qty.</i>	<i>Description</i>	<i>Ref.</i>	<i>Part Number</i>	<i>Qty.</i>	<i>Description</i>
1	126-7045	1	Front Axle ASM	15	126-0980	2	Screw-CARR
1:2	126-7048	4	Bearing-Sleeve	16	135-2882	6	Nut-HF
1:3	126-1375	3	Zerk-Grease	17	3257-7	1	Key-Woodruff
2	126-0656	1	Washer-Flat	18	135-3155	1	Motion Handle ASM
3	126-3841	1	Nut-Hex, NI	18:2	135-2844	1	Decal-Warning
4	135-3156	1	Steering Shaft ASM	19	126-1598	1	Motion Handle ASM
4:2	126-1375	1	Zerk-Grease	19:2	103-9928	2	Bearing
5	126-7044	4	Washer-Thrust	20	126-0496	1	Shaft-Pivot, Speed Control
6	126-6733	2	Front Axle ASM	21	116-4198	1	Spacer-Shaft, Drive Lever
7	126-7069	2	Arm-Steering	22	117-8304	2	Screw-HHF
8	126-3875	4	Washer	23	126-1604-03	1	Panel-Rear, Steering
10	126-7185	2	Steering Linkage ASM	24	32144-10	4	Screw-HWH
11	135-1711	4	Screw-HH	25	2411-41	2	Rod End-Ball Joint
12	98-5975	2	Washer-Belleville	26	126-0498	2	Screw-HH
13	126-7221	2	Wheel And Tire ASM	27	135-2880	2	Nut-HF
13:1	126-7261	1	Wheel ASM	28	126-2169	1	Cable-Motion
13:1:1	116-0720	2	Bearing-Ball	29	1-303335	2	Tie-Plastic
13:1:2	126-7260	1	Spacer	30	104-1412	2	Bumper-Rubber
13:2	126-1509	1	Tire	31	3210-9	2	Screw-HH
13:3	232-27	1	Stem-Valve	32	32152-5	2	Nut-Hex
13:4	302-62	1	Fitting-Grease	33	126-7050	2	Spacer-Relief
14	116-9789	1	Bumper-Front				

Steering Linkage Assembly No. 126-7185

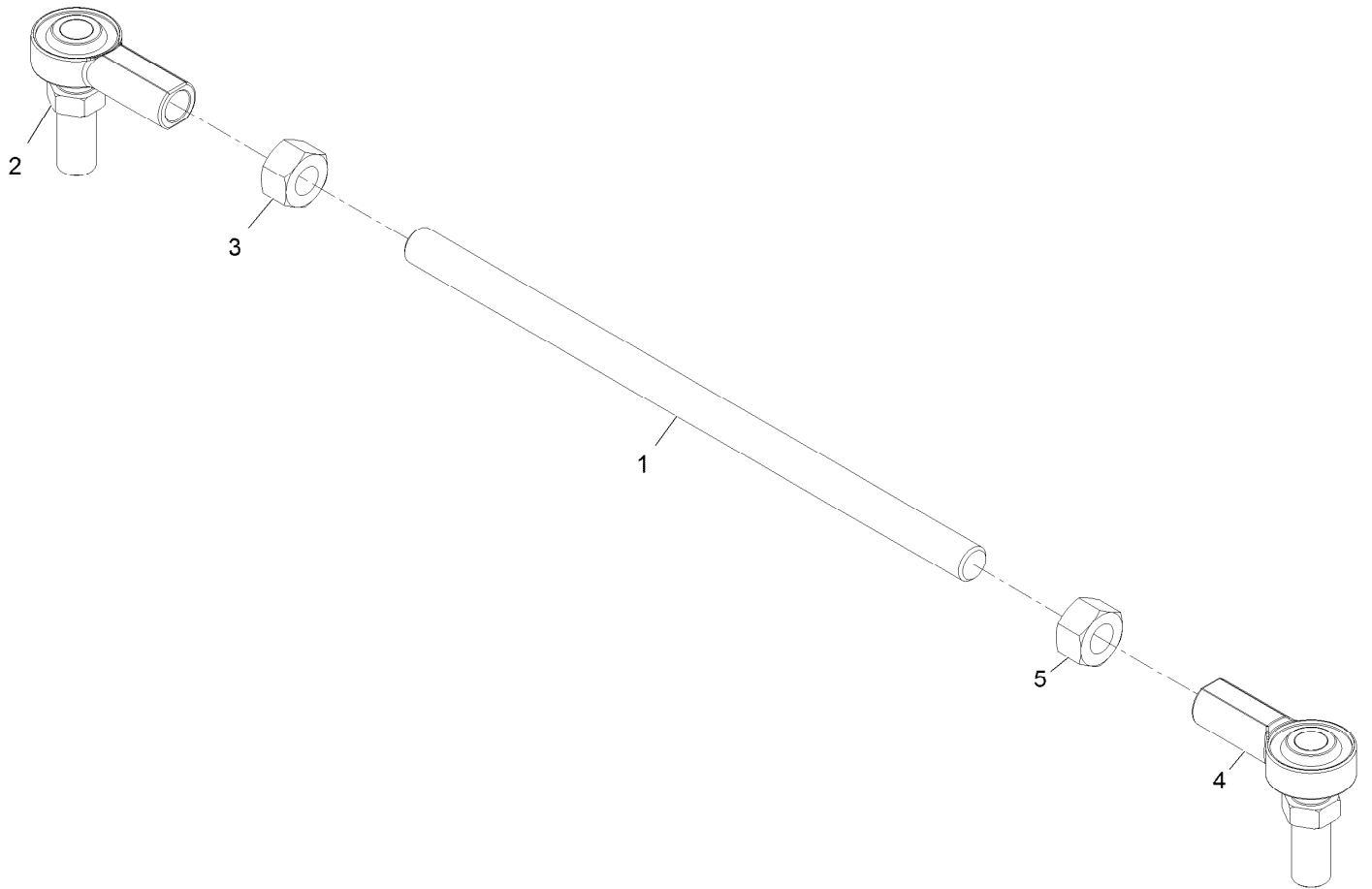

Steering Linkage Assembly No. 126-7185 (continued)

<i>Ref.</i>	<i>Part Number</i>	<i>Qty.</i>	<i>Description</i>
1	126-7183	1	Rod-Linkage, Steering
2	126-7181	1	Rod-End, RH
3	126-0687	1	Nut-Hex

<i>Ref.</i>	<i>Part Number</i>	<i>Qty.</i>	<i>Description</i>
4	126-7182	1	Rod-End, LH
5	126-0688	1	Nut-Hex, LH

Ground Drive Assembly (continued)

<i>Ref.</i>	<i>Part Number</i>	<i>Qty.</i>	<i>Description</i>	<i>Ref.</i>	<i>Part Number</i>	<i>Qty.</i>	<i>Description</i>
1	126-2814	1	Transaxle	28	126-0520	1	Screw-HH
2	3230-26	4	Screw-CARR	29	135-2882	2	Nut-HF
3	135-2881	2	Nut-HF	30	126-0433	1	Brake Lever ASM
4	135-1898	2	Wheel And Tire ASM (Grey)	30:2	116-4279	2	Bearing-Flange
4:1	119-8907	1	Tire-4 Ply	31	92-1057	1	Bolt-Shoulder
4:2	135-1899	1	Wheel (Grey)	32	2411-41	1	Rod End-Ball Joint
4:3	232-27	1	Stem-Valve	33	1-303334	2	Washer-Spring
4:99	107-2491	1	Tube-Tire ●	34	126-4009	1	Screw-HH
6	135-1711	2	Screw-HH	35	3220-1	1	Nut-Jam
7	126-2983	1	Spacer-Shaft, Input	36	3256-78	2	Washer-Flat
8	3290-317	1	Washer-Spring	37	1-323245	1	Spring-Compression
9	116-9787	1	Hub-Shaft, Transaxle	38	612503	1	Spacer
10	605256	1	Spacer	39	321-8	1	Screw-HH
11	32151-61	1	Ring-Retaining	40	126-4423-03	1	Bracket-Mount, Tank
12	27-6590	4	Spacer-Coupling, Rubber	41	126-0695	2	Screw-CARR
13	115-4523	2	Coupling-Rubber	42	126-2927	1	Fitting-90 DEG
14	3210-8	4	Screw-HH	42:1	237-42	1	O-Ring
15	3256-3	4	Washer-Flat	43	126-2578	1	Tank ASM
16	32152-5	8	Nut-Hex	43:1	126-2579	1	Cap-Tank
17	135-5223-03	1	Shaft-Drive	44	126-2842	1	Hose-Expansion
18	125-9249	4	Spacer-Coupler, Rubber	45	126-3749	2	Clamp
19	3210-5	4	Screw-HH	46	119-1730	2	Receptacle-Clip, Mini
20	116-9788	1	Hub-Shaft, Engine	47	126-1462	1	Transaxle Cover ASM
21	3246-18	2	Setscrew	48	126-2980	1	Fan-7 Inch
22	126-6243-03	1	Arm-Motion	49	1-543610	2	Washer-Clutch
23	126-4295	1	Pin-Spiral	52	104-8300	4	Nut-HF, NI
24	126-2811-03	1	Arm-Release	53	126-9884	2	Wheel Hub ASM
25	126-0498	3	Screw-HH	53:2	10-6830	4	Stud-Type, Drive
26	135-2880	4	Nut-HF	54	242-50	4	Nut-Lug
27	126-3937-03	1	Arm-Brake				

● Not illustrated

Transaxle Cover Assembly No. 126-1462

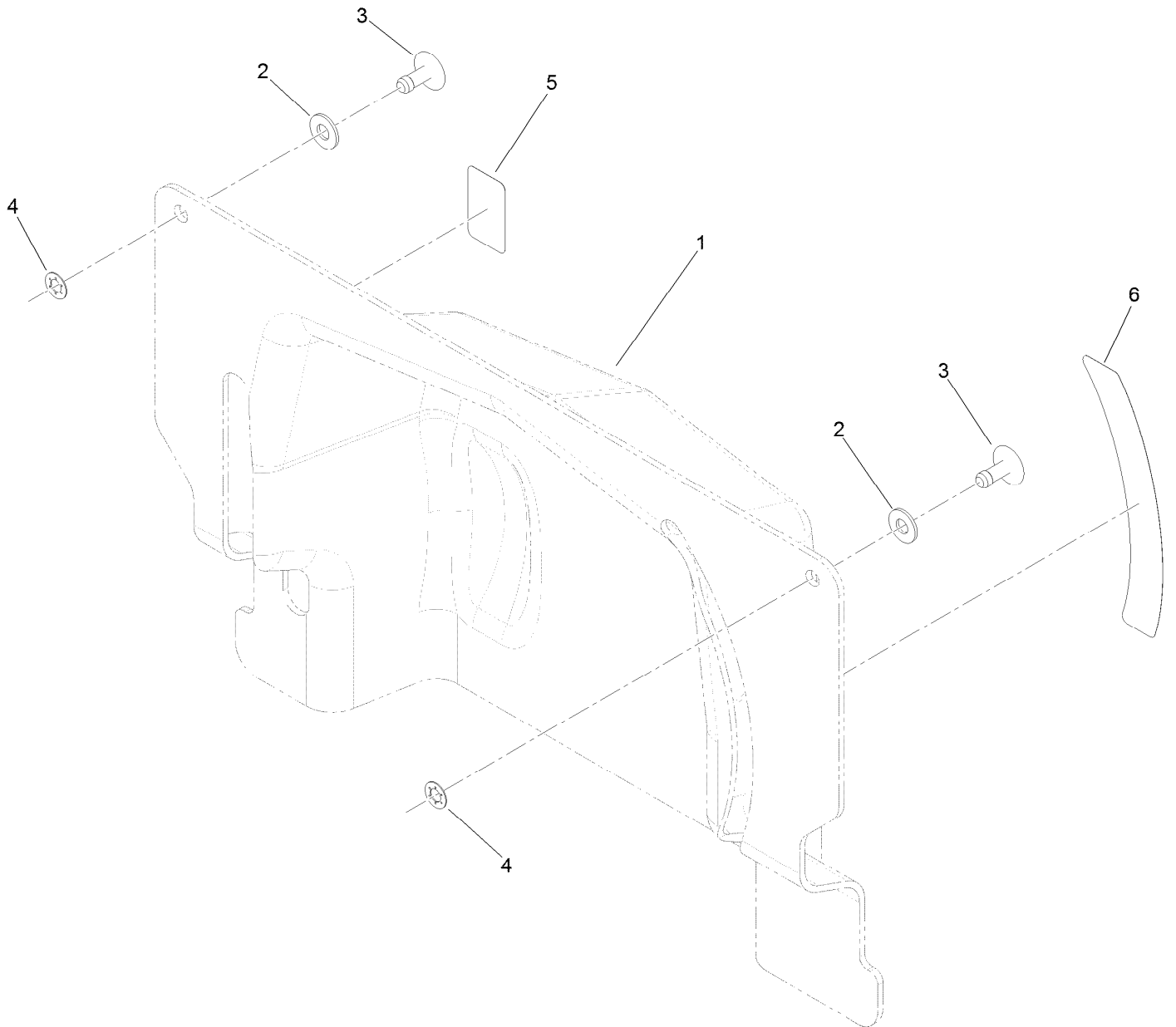

Transaxle Cover Assembly No. 126-1462 (continued)

<i>Ref.</i>	<i>Part Number</i>	<i>Qty.</i>	<i>Description</i>	<i>Ref.</i>	<i>Part Number</i>	<i>Qty.</i>	<i>Description</i>
1		1	Cover-Transaxle ●	4	119-1729	2	Retainer-Stud
2	360-0140	2	Washer-Flat	5	126-2620	1	Decal-Brake, Park
3	119-1728	2	Stud-1/4 Turn	6	126-2621	1	Decal-Release, Drive

● Not serviced separately

Engine Assembly (continued)

<i>Ref.</i>	<i>Part Number</i>	<i>Qty.</i>	<i>Description</i>	<i>Ref.</i>	<i>Part Number</i>	<i>Qty.</i>	<i>Description</i>
1	126-1359	1	Engine-Kohler, Ch395	11	135-2880	2	Nut-HF
2	135-3980	1	Key-Square, 7Mm	12	135-3149	1	Control-Throttle
3	135-7026	1	Regulator-Trombetta, 18A	13	1-807513	2	Bolt-CARR
4	126-2710	4	Screw-HHF	14	3296-2	2	Nut-Lock, NI
5	135-2882	4	Nut-HF	15	135-3150	1	Cable-Choke, Push/Pull
6	126-9978	1	Valve-Drain, Oil	16	133-8062	1	Decal-Arrestor, Spark
7	126-2225	1	Heat Shield ASM	17	135-4328	1	Bolt-M5X0.8Mm X 40 Mm Long
8	115-8486	2	Screw-HH	18	126-0759	1	Washer-Flat
9	120-1177	1	Screw-HH				
10	126-1455	2	Screw-CARR				

Electrical Assembly

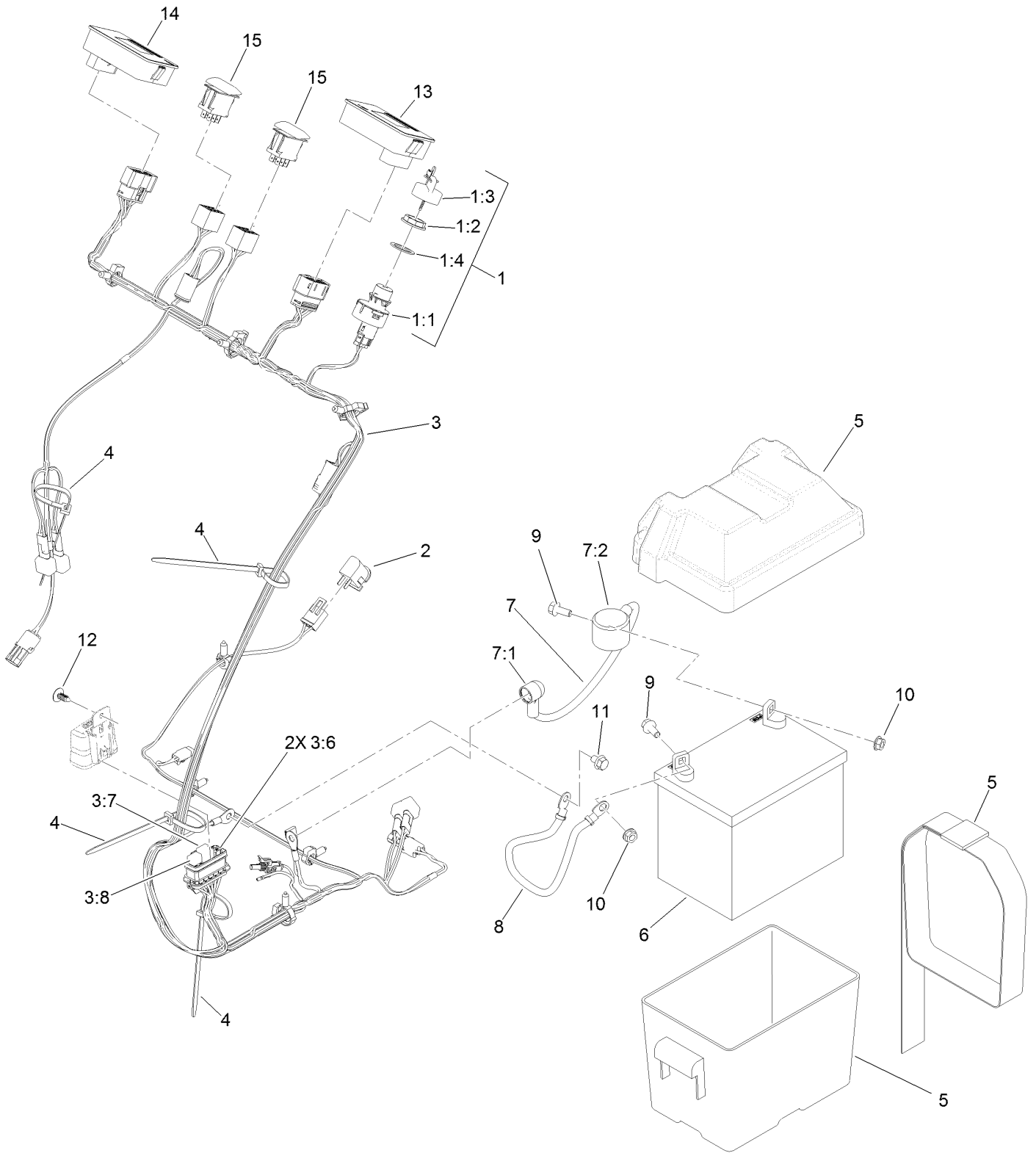

Electrical Assembly (continued)

<i>Ref.</i>	<i>Part Number</i>	<i>Qty.</i>	<i>Description</i>	<i>Ref.</i>	<i>Part Number</i>	<i>Qty.</i>	<i>Description</i>
1	126-6285	1	Ignition Switch ASM	7	135-4669	1	Positive Battery Cable ASM
1:1		1	Switch-Ignition ●	7:1	1-543393	1	Insulator-Solenoid
1:2	108-8660	1	Nut-Mounting	7:2	109-2407	1	Insulator-Battery
1:3	106-5270	1	Ignition Key Set	8	114-9715	1	Cable-Battery, Negative
1:4	108-8659	1	Washer-Backup	9	126-2712	2	Screw-HHF 5/16-18 X 3/4 SS
2	82-2190	1	Switch	10	135-2881	2	Nut-HF
3	135-6127	1	Harness-Wire	11	68-9410	1	Screw-HHF
3:6	121-8868	2	Fuse-Mini Blade, 20 Amp	12	117-2382	1	Plug-Plastic
3:7	126-3991	1	Relay-Micro	13	135-6674	1	Hour Meter ASM
3:8	135-5221	1	Relay-Coil, NC, Mp280	14	135-6675	1	Hour Meter ASM
4	1-303335	4	Tie-Cable 7 15/16 (Large)	15	100-1535	2	Switch-Rocker, (On)-Off-(On)
5	126-1424	1	Battery Box				
6		1	Battery ●				

● Not serviced separately

Spray System Assembly

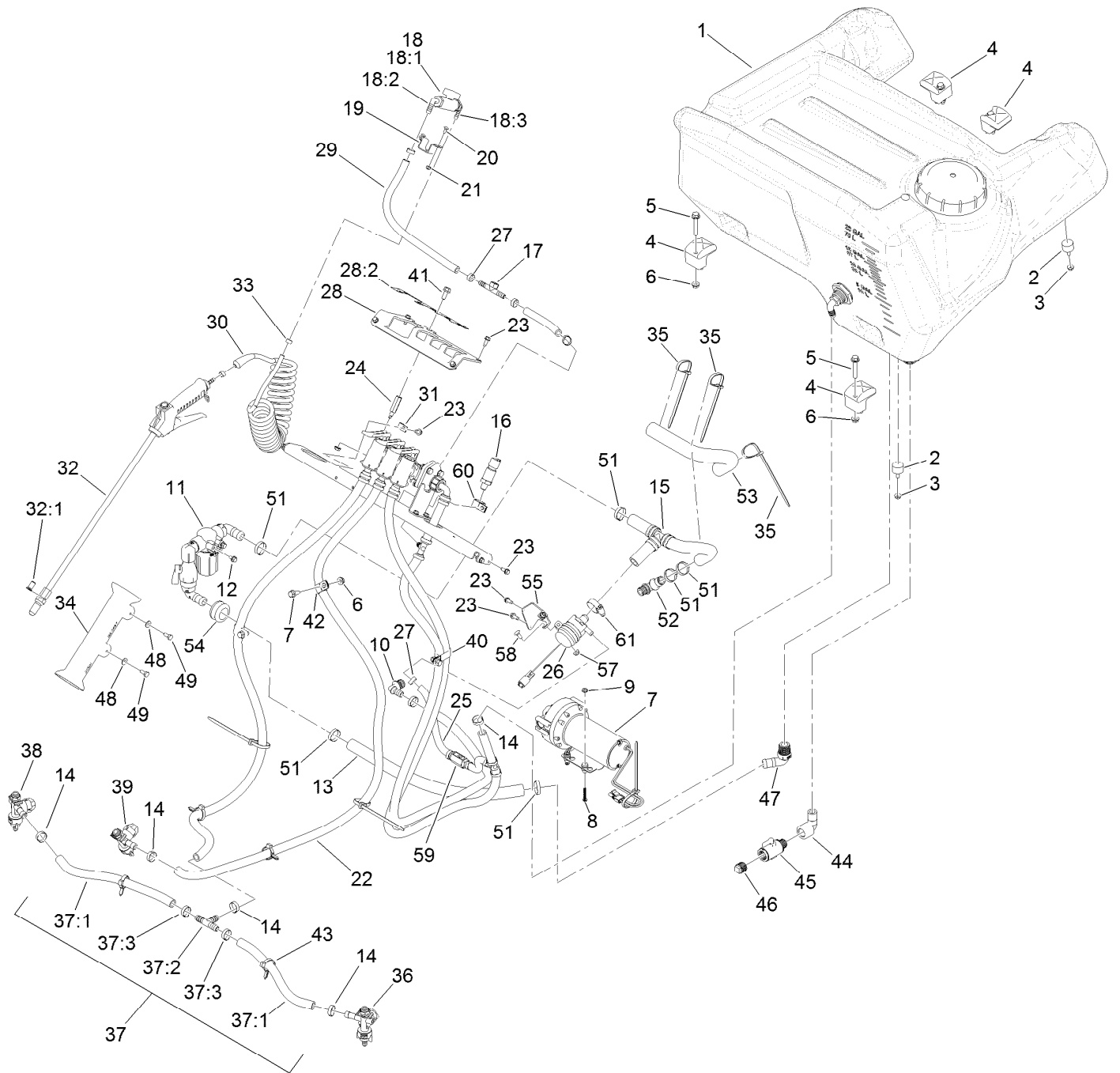

Spray System Assembly (continued)

<i>Ref.</i>	<i>Part Number</i>	<i>Qty.</i>	<i>Description</i>	<i>Ref.</i>	<i>Part Number</i>	<i>Qty.</i>	<i>Description</i>
1	126-0286	1	Tank-Sprayer	30	126-1493	1	Hose-Coiled
2	1-523420	4	Bumper	31	2412-89	1	Clamp-R
3	135-2880	5	Nut-HF	32	126-8000	1	Spray Wand ASM
4	107-4543	4	Clamp	32:1	126-3943	1	Strainer-Nozzle, 50M 5PSI Check
5	126-2711	4	Screw-HHF	33	126-2707	2	Clamp
6	135-2881	7	Nut-HF	34	126-3987	1	Holder-Wand
7	142-2301	1	Pump-Diaphragm, 3.8 GPM	35	1-303335	5	Tie-Plastic
8	692501	4	Screw-SHWH	36	126-3667	1	Left Nozzle Sub ASM
9	126-2645	4	Nut-HF	37	126-2252	1	Hose ASM
10	126-0961	1	Fitting-Elbow, Barbed	37:1	126-2264	2	Hose-Water
11	126-4358	1	Strainer ASM	37:2	126-0968	1	Fitting-Tee
12	126-2713	2	Screw-HHF	37:3	126-4778	2	Clamp
13	126-4422	1	Hose-Water	38	126-3669	1	Right Nozzle Sub ASM
14	126-4778	8	Clamp	39	126-3668	1	Center Nozzle Sub ASM
15	142-2192	1	ASM-, 3/4 Pvc Reinforced Water Hose	40	120-1959	1	Clamp
16	135-6193	1	Transducer-Pressure	41	126-2712	4	Screw-HHF
17	126-2348	1	Fitting-Tee	42	1-633396	2	Clip-Loom
18		1	Wand Control ASM ●	43	105-1853	4	Clamp-Hose
18:1	126-0242	1	Valve-Ball	44	108-3573	1	Elbow-90 DEG
18:2	126-4992	1	Fitting-Elbow-90	45	126-1494	1	Microvalve
18:3	126-4993	1	Fitting-Elbow-90	46	363-3125	1	Plug
19	126-0239-03	1	Bracket-Valve	47	119-0490	1	Elbow-Hosebarb
20	1-807513	2	Bolt-CARR	48	360-0140	2	Washer-Flat
21	3296-2	2	Nut-Lock, NI	49	126-1290	2	Screw-HH
22		1	Manifold-Valve, Control ASM ●	51	126-4779	6	Clamp
23	32144-10	11	Screw-HWH	52	126-4420	1	Fitting-Elbow
24	135-6461	1	Spacer, Manifold Mount	53	126-5065	1	Sleeve-Corrugated, Split
25	142-2213	1	Hose-Water	54	126-7410	1	Grommet
26	135-7843	1	Pump-Centrifugal	55	135-7913-03	1	Brkt-Recir Pump
27	126-3749	5	Clamp	57	104-7201	2	Nut-HF
28	126-4180	1	Cover-Controls	58	3229-11	2	Screw-CARR
28:2	135-7256	1	Decal-Lever Control	59	142-2180	1	Valve-3/8 Check
29	126-5847	1	Hose-Water, 3/8 Pvc Red	60	110-0824	1	R-Clamp
				61	2412-129	1	Clamp-Hose

● Not serviced separately

Sprayer Tank Assembly No. 126-0286

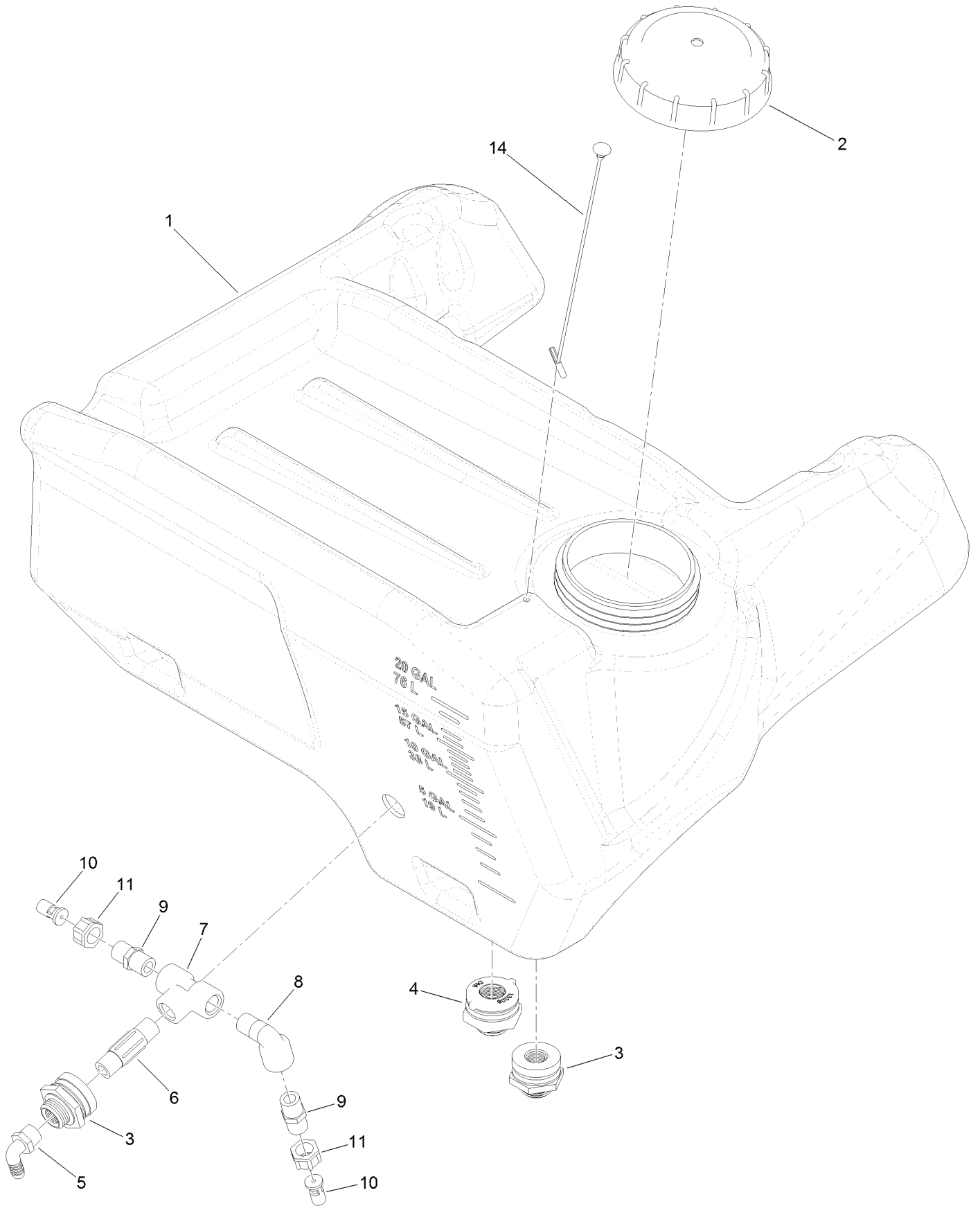

Sprayer Tank Assembly No. 126-0286 (continued)

<i>Ref.</i>	<i>Part Number</i>	<i>Qty.</i>	<i>Description</i>	<i>Ref.</i>	<i>Part Number</i>	<i>Qty.</i>	<i>Description</i>
1		1	Tank-Sprayer ●	8	108-3573	1	Elbow-90 DEG
2	126-0285	1	Cap-Water, 5 Inch Vent	9	108-3574	2	Nipple-Short
3	126-0400	2	Fitting-Bulkhead	10	100-6705	2	Nozzle-Agitation
4	126-4393	1	Fitting-Bulkhead	11	99-0766	2	Nut
5	42046	1	Elbow-90 DEG	14	126-3381	1	Lanyard-Cap, Self Anchoring (12 Inch)
6	94-7103	1	Nipple				
7	94-7100	1	Tee				

● Not serviced separately

Strainer Assembly No. 126-4358

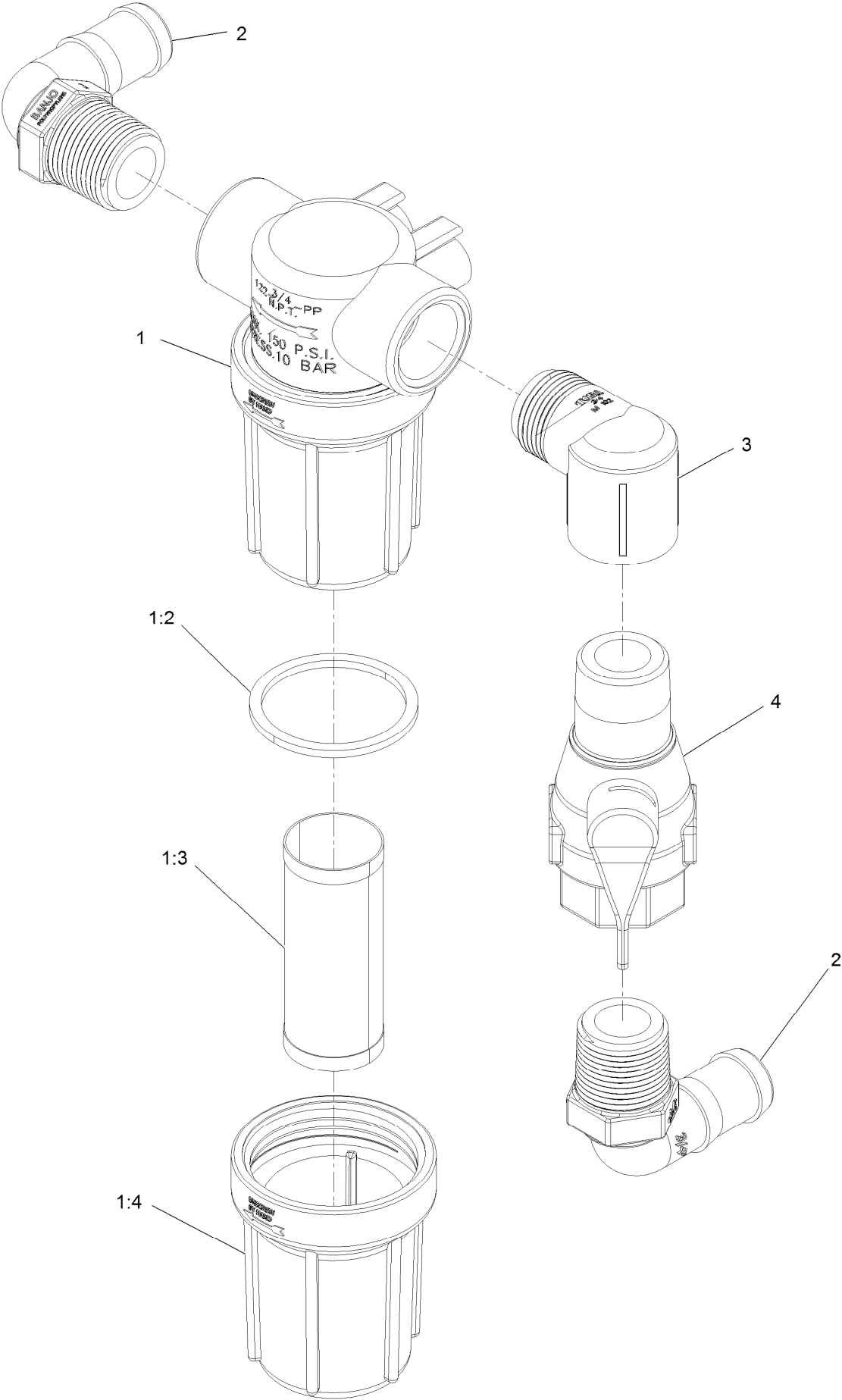

Strainer Assembly No. 126-4358 (continued)

<i>Ref.</i>	<i>Part Number</i>	<i>Qty.</i>	<i>Description</i>
1	126-4374	1	Strainer-Line
1:2	126-2272	1	Gasket-Head, Line Strainer
1:3	126-2273	1	Screen-Strainer, 30 Mesh SS

<i>Ref.</i>	<i>Part Number</i>	<i>Qty.</i>	<i>Description</i>
1:4	126-7195	1	Bowl-Strainer
2	119-0490	2	Elbow-Hosebarb
3	102-4272	1	Elbow
4	126-4451	1	Valve-Ball

Control Valve Manifold and Hose Assembly

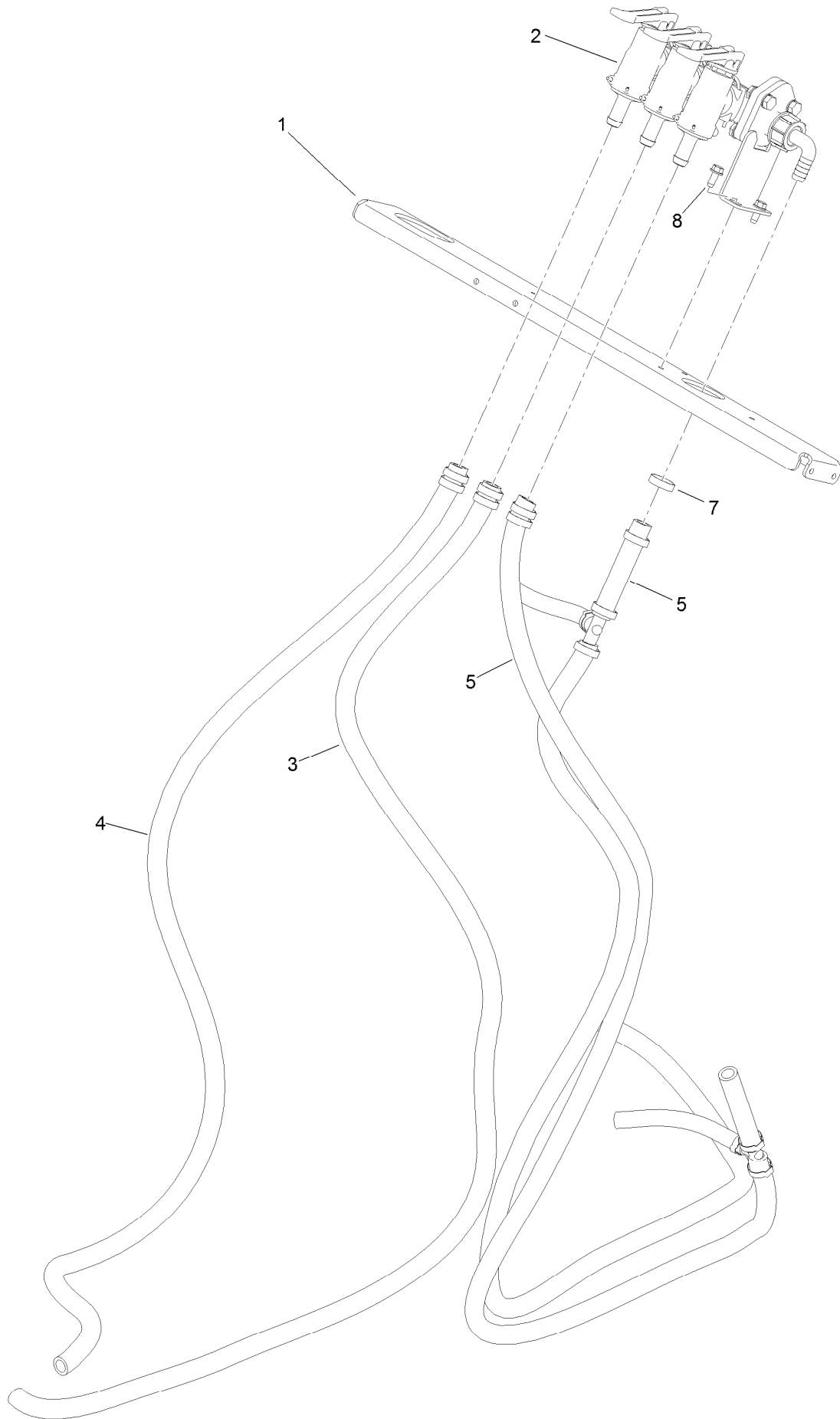

Control Valve Manifold and Hose Assembly (continued)

<i>Ref.</i>	<i>Part Number</i>	<i>Qty.</i>	<i>Description</i>
1	135-6360-03	1	Crossmember-Column
2	135-6362	1	Manifold-Valve, Control
3	126-2261	1	Hose-Water
4	126-2263	1	Hose-Water

<i>Ref.</i>	<i>Part Number</i>	<i>Qty.</i>	<i>Description</i>
5	142-3560	2	Hose ASM
7	126-4778	8	Clamp
8	32144-10	2	Screw-HWH

Control Valve Manifold Assembly No. 135-6362

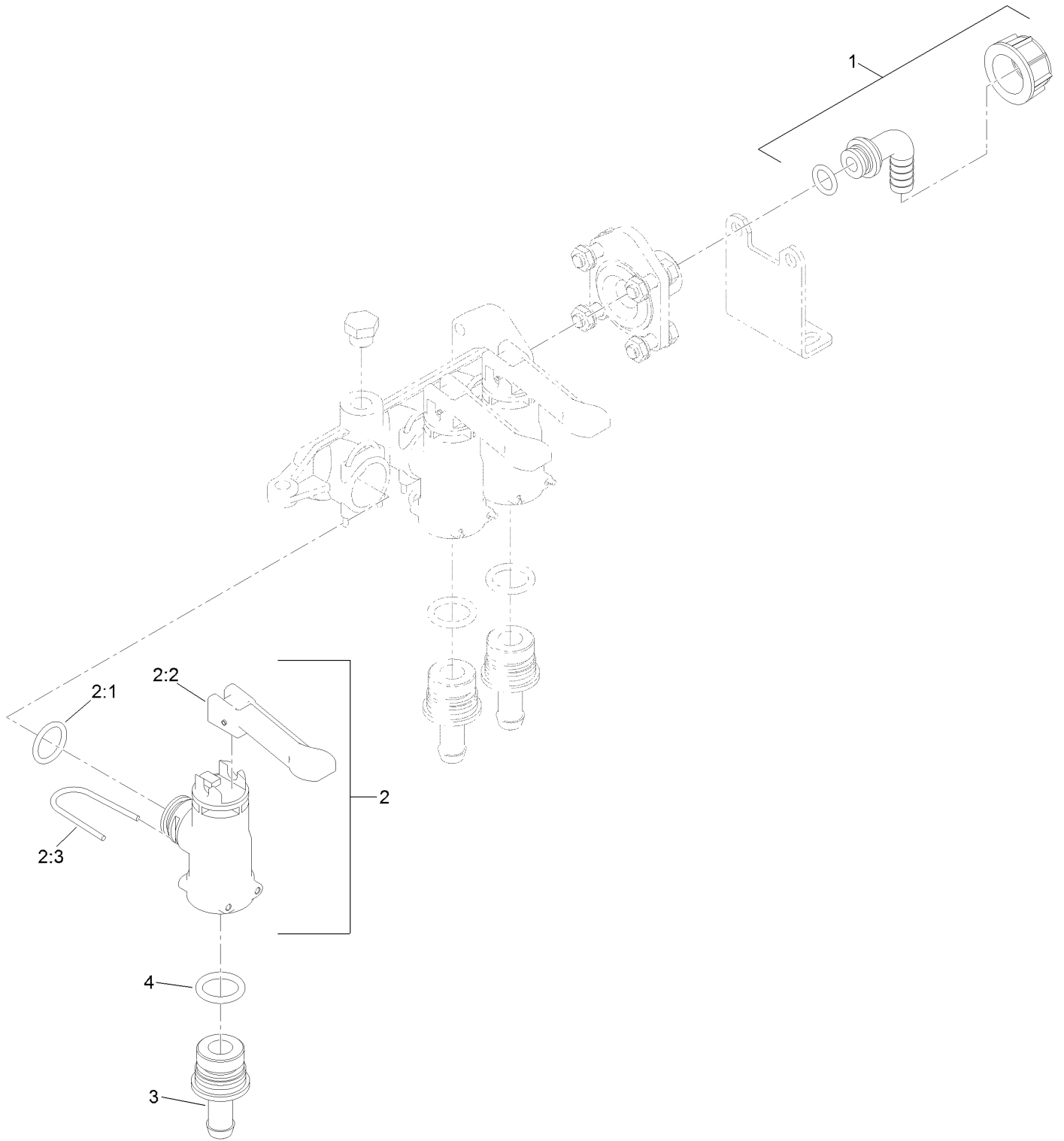

Control Valve Manifold Assembly No. 135-6362 (continued)

<i>Ref.</i>	<i>Part Number</i>	<i>Qty.</i>	<i>Description</i>	<i>Ref.</i>	<i>Part Number</i>	<i>Qty.</i>	<i>Description</i>
1	135-6464	1	Flynut Assembly	2:3	126-6332	1	Wireform Retainer Kit
2	126-7641	1	Valve Assembly W/ O-Ring	3	126-6321	1	Hose Barb
2:1	126-6328	1	O-Ring Kit, Valve Inlet	4	126-6327	1	O-Ring Kit, Valve Outlet
2:2	126-6319	1	Lever And Pin Assembly				Barb

Left Nozzle Assembly No. 126-3667

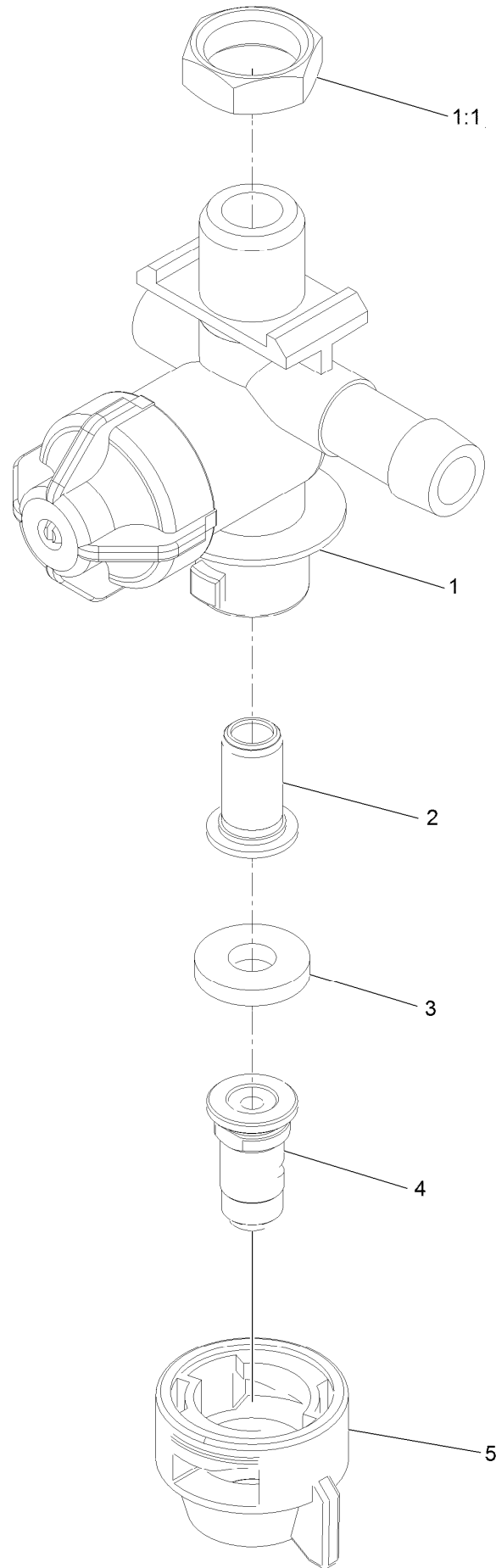

Left Nozzle Assembly No. 126-3667 (continued)

<i>Ref.</i>	<i>Part Number</i>	<i>Qty.</i>	<i>Description</i>	<i>Ref.</i>	<i>Part Number</i>	<i>Qty.</i>	<i>Description</i>
1	116-9790	1	LH Nozzle Body ASM	5	116-9796	1	Cap-Nozzle
1:1	126-2801	1	Nut-Nylon	99	126-7172	1	Nozzle-Spray, Blue ●■
2	126-1212	1	Strainer-Tip	99	126-7171	1	Nozzle-Spray, Brown ●■
3	116-9797	1	Gasket-Seal	99	126-7170	1	Nozzle-Spray, Gray ●■
4	116-9798	1	Nozzle-Spray, White	99	126-2566	1	Nozzle-Spray, Red ●■

● Not illustrated

■ Sold separately

Right Nozzle Assembly No. 126-3669

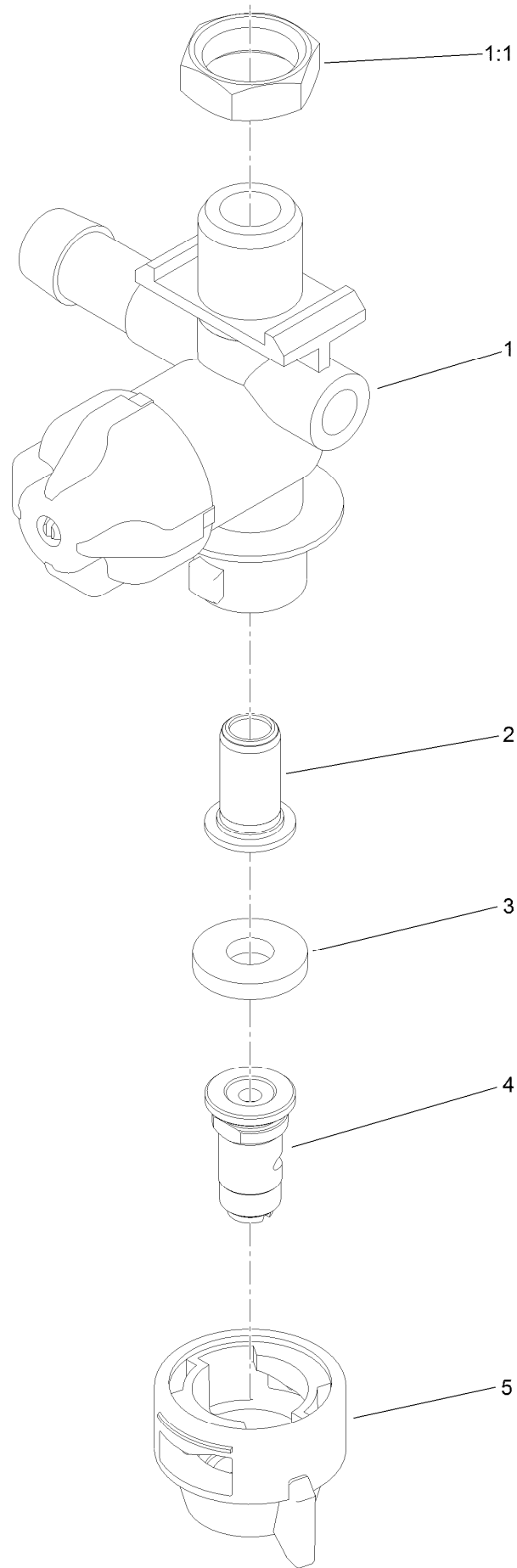

Right Nozzle Assembly No. 126-3669 (continued)

<i>Ref.</i>	<i>Part Number</i>	<i>Qty.</i>	<i>Description</i>	<i>Ref.</i>	<i>Part Number</i>	<i>Qty.</i>	<i>Description</i>
1	116-9791	1	RH Nozzle Body ASM	5	116-9796	1	Cap-Nozzle
1:1	126-2801	1	Nut-Nylon	99	126-7172	1	Nozzle-Spray, Blue ●
2	126-1212	1	Strainer-Tip	99	126-7171	1	Nozzle-Spray, Brown ●
3	116-9797	1	Gasket-Seal	99	126-7170	1	Nozzle-Spray, Gray ●
4	116-9798	1	Nozzle-Spray, White	99	126-2566	1	Nozzle-Spray, Red ●

● Not illustrated

Center Nozzle Assembly No. 126-3668

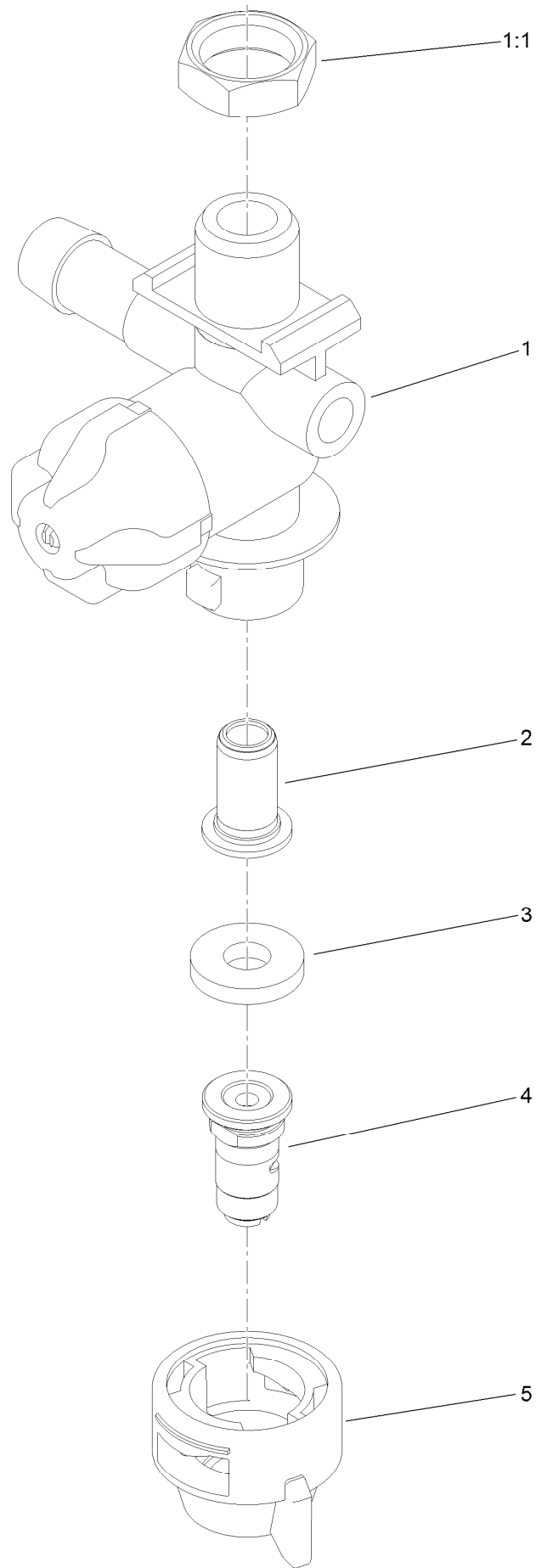

Center Nozzle Assembly No. 126-3668 (continued)

<i>Ref.</i>	<i>Part Number</i>	<i>Qty.</i>	<i>Description</i>	<i>Ref.</i>	<i>Part Number</i>	<i>Qty.</i>	<i>Description</i>
1	116-9791	1	RH Nozzle Body ASM	5	116-9796	1	Cap-Nozzle
1:1	126-2801	1	Nut-Nylon	99	126-7170	1	Nozzle-Spray, Gray ●■
2	126-1212	1	Strainer-Tip	99	116-9798	1	Nozzle-Spray, White ●■
3	116-9797	1	Gasket-Seal	99	126-7171	1	Nozzle-Spray, Brown ●■
4	126-2566	1	Nozzle-Spray, Red	99	126-7172	1	Nozzle-Spray, Blue ●■

● Not illustrated

■ Sold separately

Spreader Assembly

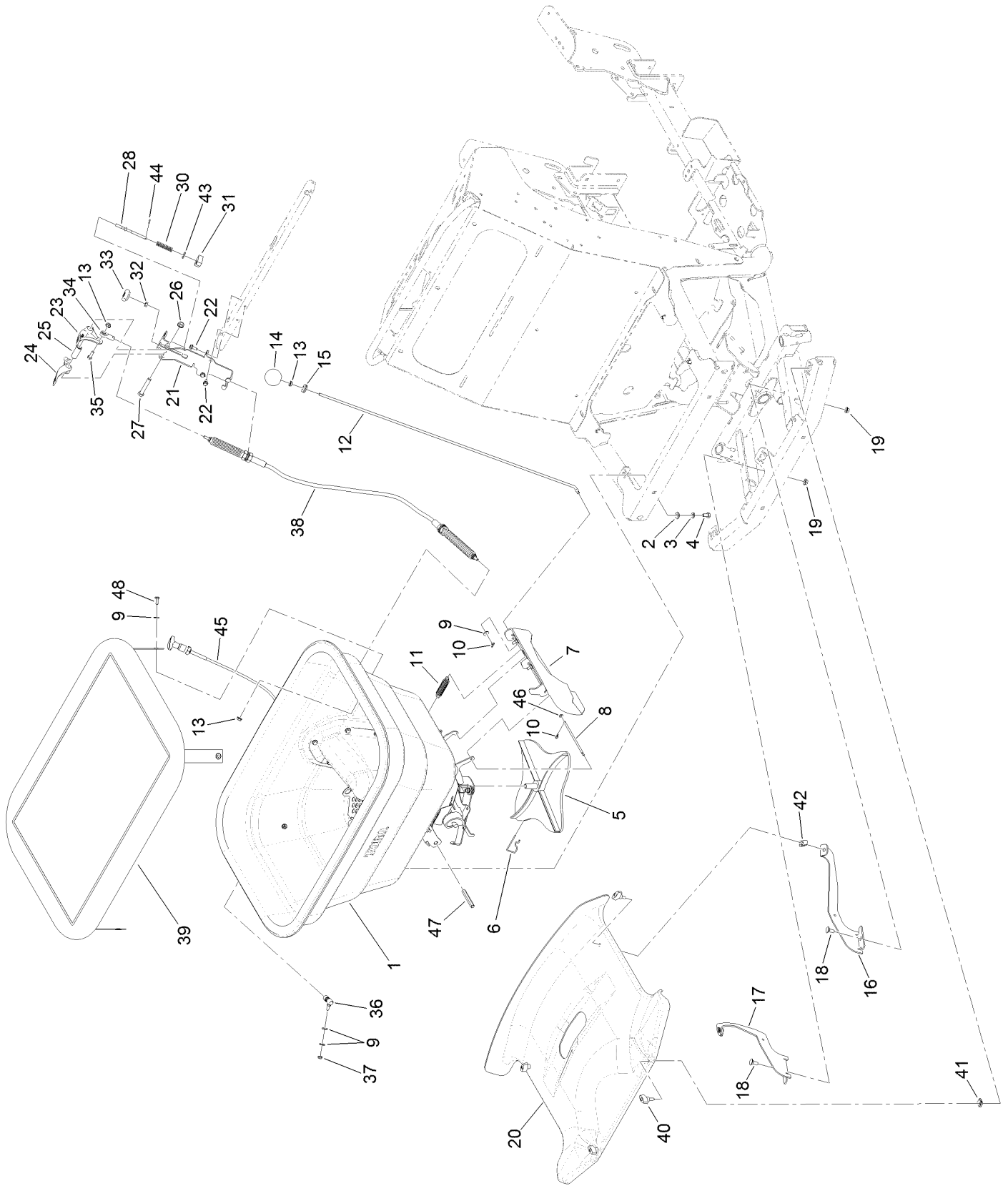

Spreader Assembly (continued)

<i>Ref.</i>	<i>Part Number</i>	<i>Qty.</i>	<i>Description</i>	<i>Ref.</i>	<i>Part Number</i>	<i>Qty.</i>	<i>Description</i>
1		1	Spreader Hopper ASM ●	24	126-3948	1	Lever-Spread, Narrow
2	107-0279	4	Washer	25	126-3984	1	Spacer
3	107-0280	4	Washer-Lock	26	135-2882	1	Nut-HF
4	126-2506	4	Screw-HH	27	323-11	1	Screw-HH
5	126-0858	1	Spinner-Spreader	28	126-3929	1	Link-Adjust, Narrow
6	126-1246	1	Clip-Spinner	30	125-0547	1	Spring-Compression, Bail
7		1	Side Deflector ASM ●	31	126-3147	1	Stop-Spread, Narrow
8	135-2558	1	Pin-Deflector	32	126-4891	1	Nut-Coupler
9	360-0140	9	Washer-Flat	33	126-3905	1	Knob
10	126-1631	2	Pin-Cotter, Hair	34	2411-41	1	Rod End-Ball Joint
11	126-2127	1	Spring-Extension	35	126-0498	1	Screw-HH
12	126-2190	1	Rod-Control, Deflector	36	126-2005	1	Ball-Joint
13	135-2880	6	Nut-HF	37	126-2725	1	Nut-Hex, NI
14	121-1877	1	Knob-Rate, Flow	38	126-1783	1	Cable
15	1-633630	1	Grommet	39	126-2815	1	Cover-Hopper
16	126-2145	1	Bracket-Cover, Front (LH)	40	126-5846	4	Knob-T
17	126-2146	1	Bracket-Cover, Front (RH)	41	126-3740	2	Nut-Retainer, U Style
18	126-0695	2	Screw-CARR	42	126-3739	2	Nut-Retainer
19	135-2881	2	Nut-HF	43	3256-78	1	Washer-Flat
20	126-2063	1	Cover-Front, Spreader/Sprayer	44	3272-5	1	Pin-Cotter
21	126-3133	1	Mount-Handle	45	126-4150	1	Cable-Control, Turn Lock
22	32144-10	3	Screw-HWH	46	126-0759	1	Washer-Flat
23	126-3947	1	Lever-Spread, Wide	47	126-4655	1	Post-Hex, Diffuser Guide
				48	126-1290	4	Screw-HH

● Not serviced separately

Spreader Hopper Assembly

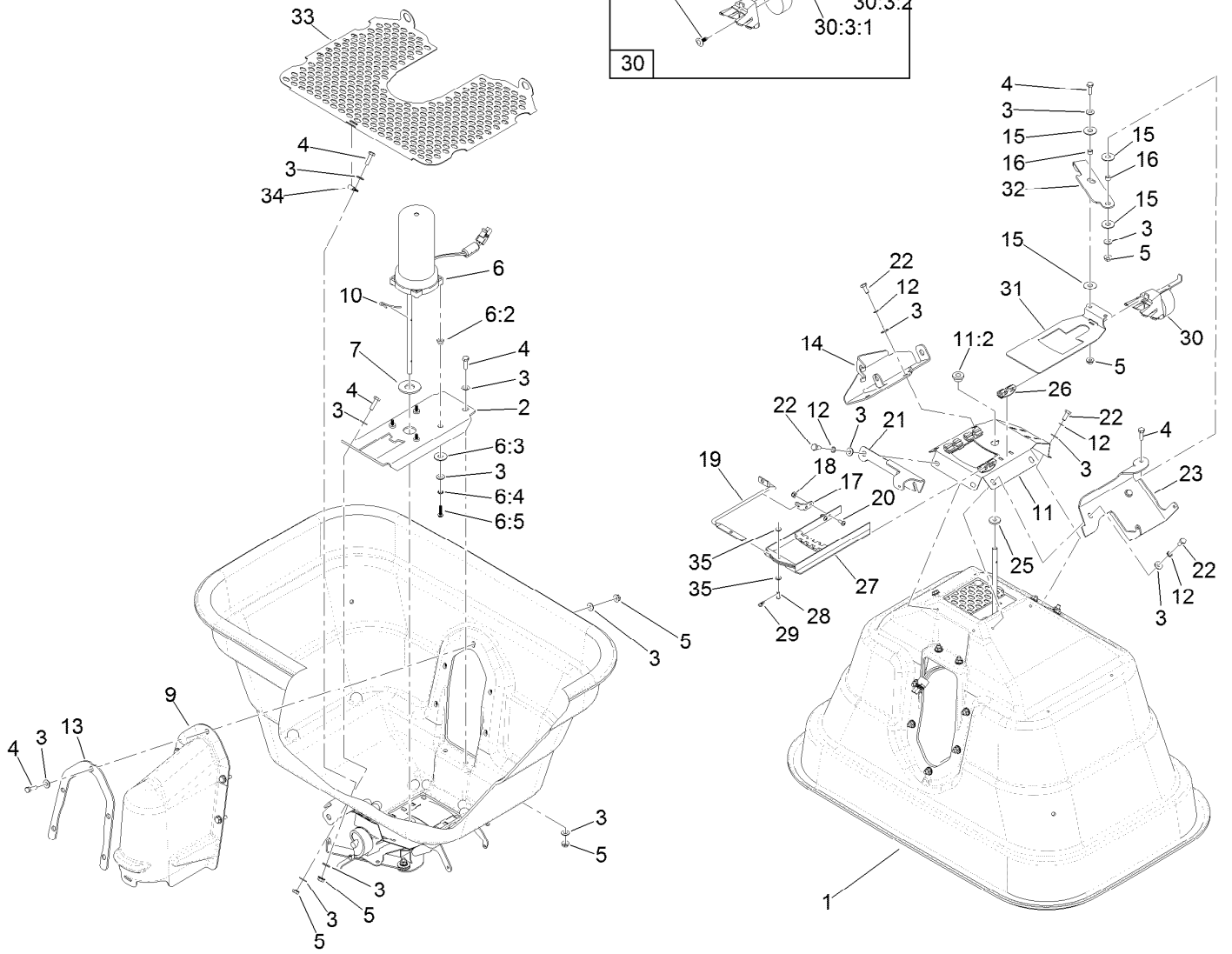
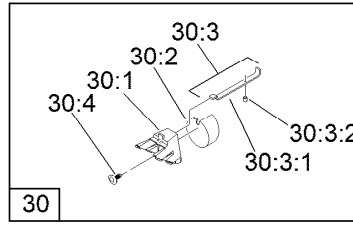

Spreader Hopper Assembly (continued)

<i>Ref.</i>	<i>Part Number</i>	<i>Qty.</i>	<i>Description</i>	<i>Ref.</i>	<i>Part Number</i>	<i>Qty.</i>	<i>Description</i>
1	142-2734	1	Hopper-Spreader, 175 Lb	20	126-9586	2	Screw-PPH
2	126-4245	1	Bracket-Mount, Motor	21	126-2082	1	Bracket-Spring, Hopper Deflector
3	360-0140	34	Washer-Flat	22	126-1290	8	Screw-HH
4	126-0498	12	Screw-HH	23	126-1916	1	Bracket-Lever, Hopper Gate
5	135-2880	12	Nut-HF	25	126-1252	1	Washer-Felt
6	126-6231	1	Spreader Motor ASM	26	126-0990	4	Guide-Rate, Gate
6:2	135-3989	4	Spacer-Flanged	27	126-0991	1	Diffuser
6:3	360-0140	4	Washer-Flat	28	126-3729	1	Pin-Clevis
6:4	363-8641	4	Washer-Lock, Int	29	126-1631	1	Pin-Cotter, Hair
6:5	739001	4	Screw-SHWH	30	126-0998	1	Rate Dial ASM
7	83-2400	1	Spacer	30:1	126-0985	1	Mount-Dial
9	126-1348	1	Cover-Motor	30:2	126-0988	1	Dial
10	126-1247	1	Agitator	30:3		1	Rate Gate Link ASM ●
11	126-6284	1	Mulch Plate W/ Bearing ASM	30:3:1	126-0987	1	Link-Gate, Rate
11:2	126-0984	1	Bearing-Bottom, Hopper	30:3:2	126-4196	1	Screw-Shoulder, Slotted
12	363-8641	12	Washer-Lock, Int	30:4	126-0986	1	Clip
13	126-6334	1	Flange-Cover, Motor	31	126-1903	1	Gate-Rate
14	126-4650	1	Bracket-Hopper, Gate Controls	32	126-4112	1	Lever-Gate
15	93-1633	4	Washer	33	126-3242	1	Screen-Hopper, Small Hole
16	126-3684	2	Spacer	33	126-3240	1	Screen-Hopper, Medium Hole
17	126-1237	1	Bracket-Diffuser	33	126-3143	1	Screen-Hopper, Large Hole
18	364-0371	2	Nut-Hex	34	126-1624	1	Clamp-Loop
19	126-1646	1	Rod-Control, Diffuser	35	126-0759	2	Washer-Flat

● Not serviced separately

Side Deflector Assembly

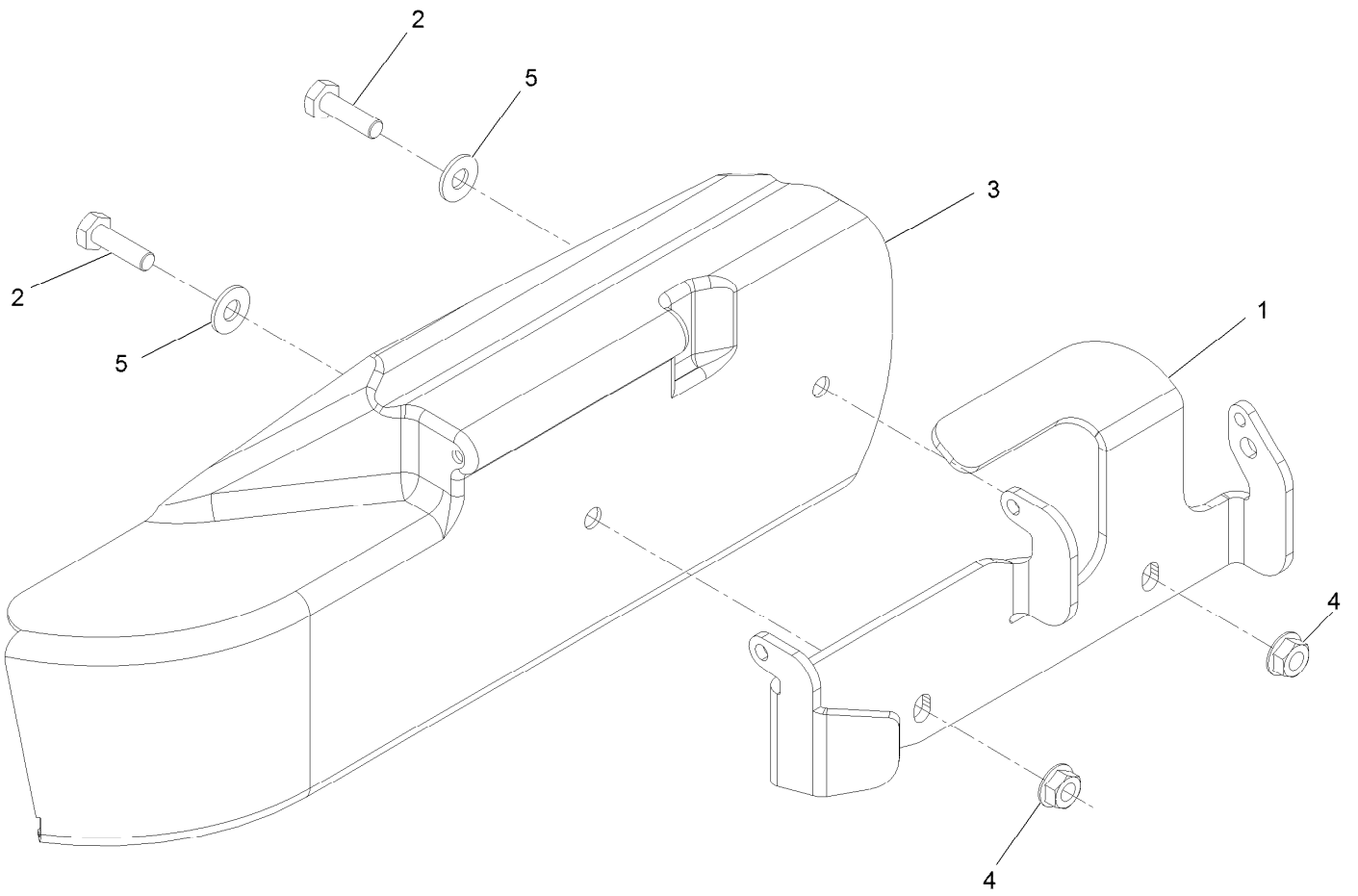

Side Deflector Assembly (continued)

<i>Ref.</i>	<i>Part Number</i>	<i>Qty.</i>	<i>Description</i>	<i>Ref.</i>	<i>Part Number</i>	<i>Qty.</i>	<i>Description</i>
1	135-2501	1	Bracket-Deflector, Side	4	135-2880	2	Nut-HF
2	126-0498	2	Screw-HH	5	360-0140	2	Washer-Flat
3	126-1217	1	Deflector-Side				

Notes:

Notes:



Count on it.