



48in, 52in, or 60in Blower and Drive Kit

Grandstand® Mower

Model No. 78525—Serial No. 400000000 and Up

Model No. 78526—Serial No. 400000000 and Up

Model No. 78527—Serial No. 400000000 and Up

Installation Instructions

Note: Install this kit to use with the E-Z Vac Twin Bagger; refer to the *Operator's Manual* for the bagger for safety, operation, and maintenance procedures.

Important: For Grandstand machines with the serial ranges listed below, engage the clutch at least 50 times before installing and operating the Blower and Drive Kit.

- Model 74513—Serial number 405291650 and before
- Model 79518—Serial number 405291708 and before
- All other models—Serial number 405453838 and before

Ensure to engage the clutch at least 45 seconds and disengage it at least 15 seconds each time. This can be accomplished through normal use of the machine before installing the kit.

⚠ WARNING

CALIFORNIA Proposition 65 Warning

Use of this product may cause exposure to chemicals known to the State of California to cause cancer, birth defects, or other reproductive harm.

Safety

Safety and Instructional Decals



Safety decals and instructions are easily visible to the operator and are located near any area of potential danger. Replace any decal that is damaged or missing.

⚠ WARNING: Cancer and Reproductive Harm - www.P65Warnings.ca.gov.
For more information, please visit www.ttcocaprop65.com

133-8061

decal133-8061

133-8061



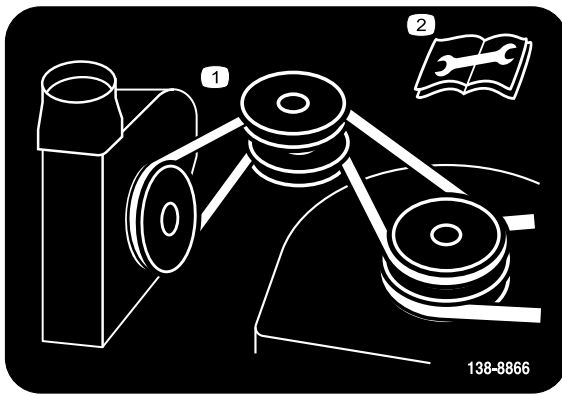

decal138-8866

138-8866

1. Belt routing
2. Read the *Operator's Manual* before performing maintenance.

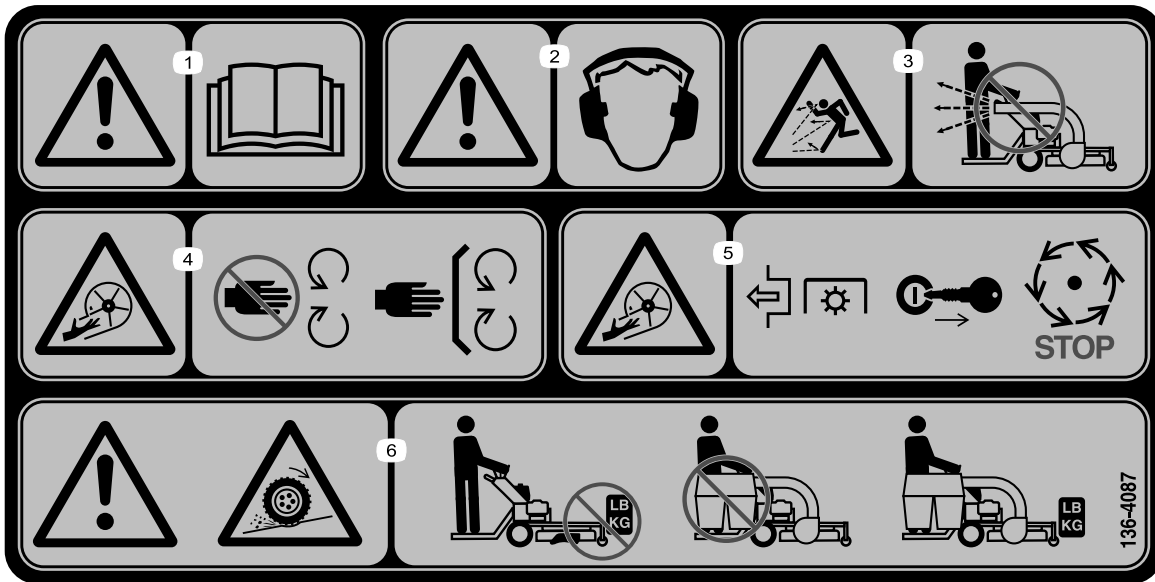

decal136-4087

136-4087

1. Warning—read the *Operator's Manual*.
2. Warning—wear hearing protection.
3. Thrown object hazard—do not operate the machine without the collection system installed and latched.
4. Cutting/dismemberment hazard of hand, impeller—stay away from moving parts; keep all guards and shields in place.
5. Cutting/dismemberment hazard of hand, impeller—disengage the PTO, remove the key, and wait for all moving parts to stop.
6. Warning; loss of traction hazard—do not operate with only the counterbalance weights installed; do not operate with only the E-Z Vac installed; only operate with both the E-Z Vac and counterbalance weights installed.

Installation

Loose Parts

Use the chart below to verify that all parts have been shipped.

Procedure	Description	Qty.	Use
1	No parts required	–	Prepare the machine.
3	Blower mount Bolt (1/2 x 1-1/2 inches) Lock washer Nut (1/2 inch) Bolt (3/8 x 1-1/4 inches) Nut (3/8 inch) Carriage bolt (3/8 x 1-1/4 inches) Carriage bolt (3/8 x 1 inch) Idler assembly Pulley assembly	1 1 1 1 1 1 1 1 1 1	Install the pulley and idler assemblies (for machines with a cast-iron spindle).
4	Pulley assembly Bolt (1/2 x 1-1/2 inches) Lock washer Nut (1/2 inch) Bolt (3/8 x 1-1/4 inches) Nut (3/8 inch) Carriage bolt (3/8 x 1-1/4 inches) Carriage bolt (3/8 x 1 inch) Pulley-plate mount Flange nut (3/8 inch)	1 1 1 1 1 1 1 1 1 3	Install the pulley assembly and belt (for machines with an aluminum spindle).
5	Blower assembly Belt Belt cover Knob Hose Hose clamp	1 1 1 1 1 1	Install the blower assembly, baffle, belt, and belt cover.

Note: Determine the left and right sides of the machine from the normal operating position.

1

Preparing the Machine

No Parts Required

Procedure

Perform the following procedure to prepare the machine for attaching the blower and finishing kit.

1. Disengage the PTO, move the motion-control levers to the NEUTRAL-LOCK position, and engage the parking brake.
2. Shut off the engine, remove the key, and wait for all moving parts to stop before leaving the operating position.
3. Repair all bent or damaged areas of mower deck and replace any missing parts.
4. Clean the machine of any debris on the deck or rear part of the machine to ease installation.

2

Removing the Discharge Chute and Existing Belt Cover

No Parts Required

Procedure

Note: Retain all parts and install them on the machine whenever you remove the bagger.

1. Remove the bolt (5/16 x 7-1/2 inches) and nut (5/16 inch) securing the discharge chute to the deck. Remove the chute, spring, and spacer (Figure 1).

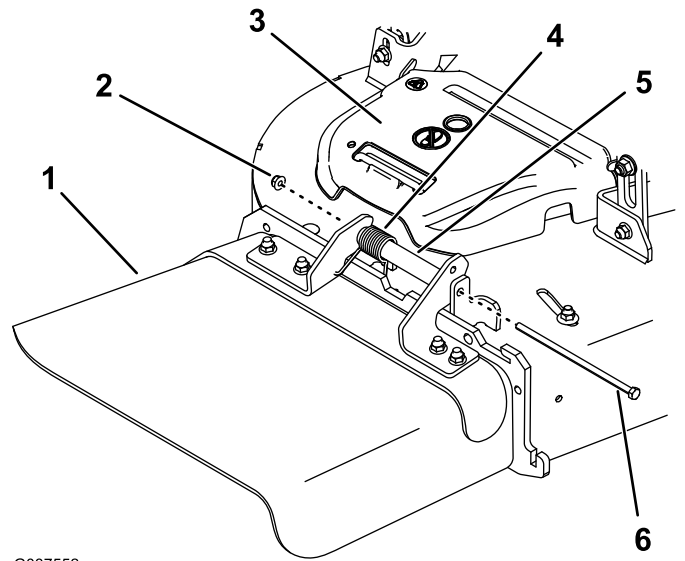

G037552

g037552

Figure 1

- | | |
|--------------------|-------------------------------|
| 1. Discharge chute | 4. Spring |
| 2. Nut (5/16 inch) | 5. Spacer |
| 3. Belt cover | 6. Bolt (5/16 x 7-1/2 inches) |

2. Remove the belt cover (Figure 1).
3. Remove the wireform, baffle, 2 carriage bolts (3/8 x 1 inch), and 4 nuts (3/8 inch) from the deck (Figure 2).

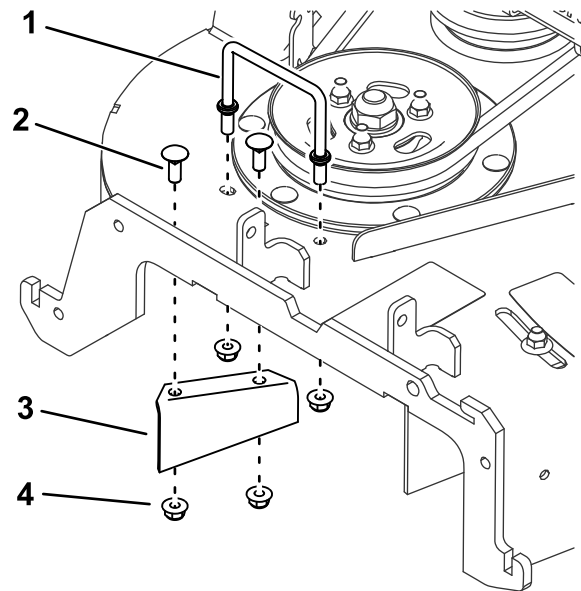

g274170

Figure 2

- | | |
|-------------------------------|---------------------|
| 1. Wireform | 3. Baffle |
| 2. Carriage bolt—3/8 x 1 inch | 4. Nut—3/8 inch (4) |

3

Installing the Pulley and Idler Assemblies

For Machines with a Cast-Iron Spindle

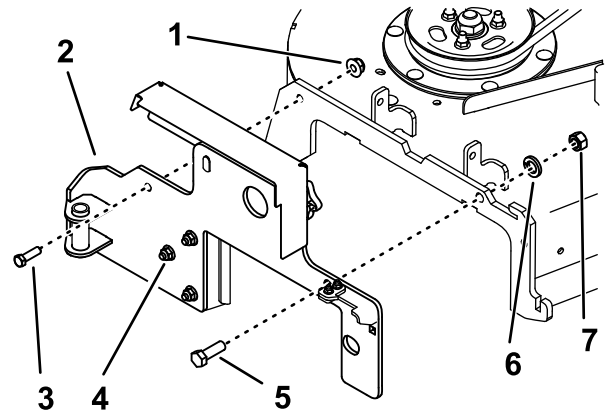

g194670

Figure 3

Parts needed for this procedure:

1	Blower mount
1	Bolt (1/2 x 1-1/2 inches)
1	Lock washer
1	Nut (1/2 inch)
1	Bolt (3/8 x 1-1/4 inches)
1	Nut (3/8 inch)
1	Carriage bolt (3/8 x 1-1/4 inches)
1	Carriage bolt (3/8 x 1 inch)
1	Idler assembly
1	Pulley assembly

1. Nut (3/8 inch)
2. Blower mount
3. Bolt (3/8 x 1-1/4 inches)
4. Baffle bolt (3)
5. Bolt (1/2 x 1-1/2 inches)
6. Lock washer
7. Nut (1/2 inch)

Procedure

1. Install the blower mount to the deck using 1 bolt (1/2 x 1-1/2 inches), 1 lock washer, 1 nut (1/2 inch), 1 bolt (3/8 x 1-1/4 inches), and 1 nut (3/8 inch) as shown in [Figure 3](#).

Note: You may need to loosen the 3 baffle bolts when you install the blower mount to align the assembly with the deck. Tighten the bolts after installing the mount.

- Remove the nuts from the spindle in the right deck pulley and use them to attach the pulley assembly to the deck pulley (Figure 4).

Note: You may need to remove the mower belt to relieve the tension off the deck pulley when you install the pulley assembly. Refer to the *Operator's Manual* for the machine.

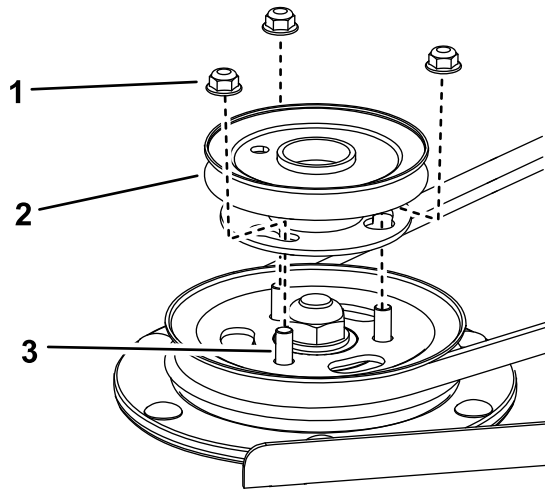

Figure 4

g255311

- Nut
- Pulley assembly
- Spindle

- Using the 3 nuts that you removed previously, 1 carriage bolt ($3/8 \times 1-1/4$ inches), and 2 carriage bolts ($3/8 \times 1$ inch), install the idler assembly to the mower deck (Figure 5).

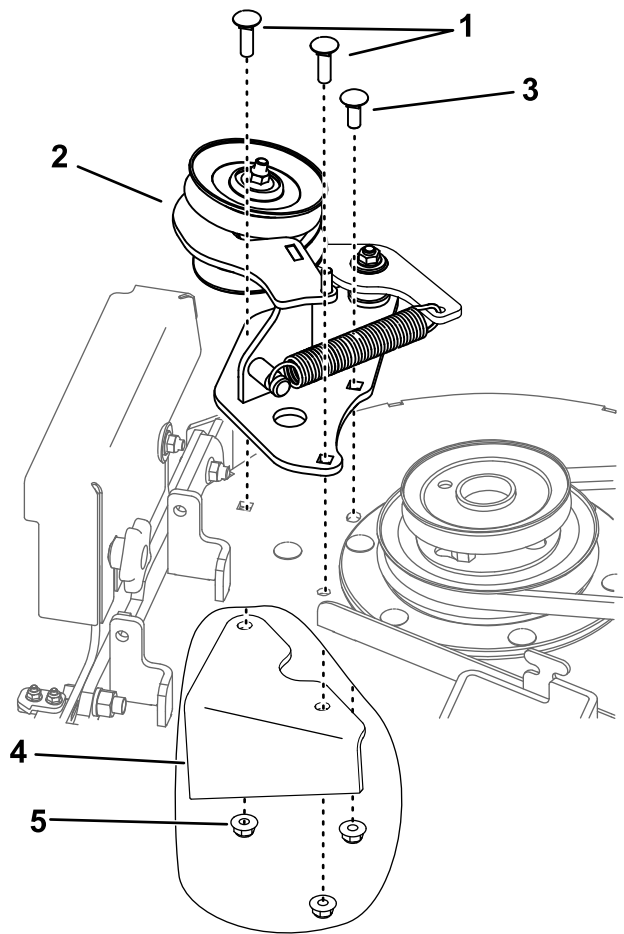

Figure 5

g274182

- Carriage bolt ($3/8 \times 1-1/4$ inches)
- Idler assembly
- Carriage bolt ($3/8 \times 1$ inch)
- Mower deck
- Nut (below the mower deck)

4

Installing the Pulley Assembly and Belt

For Machines with an Aluminum Spindle

Parts needed for this procedure:

1	Pulley assembly
1	Bolt (1/2 x 1-1/2 inches)
1	Lock washer
1	Nut (1/2 inch)
1	Bolt (3/8 x 1-1/4 inches)
1	Nut (3/8 inch)
1	Carriage bolt (3/8 x 1-1/4 inches)
1	Carriage bolt (3/8 x 1 inch)
1	Pulley-plate mount
3	Flange nut (3/8 inch)

Procedure

1. Install the blower mount to the deck using 1 bolt (1/2 x 1-1/2 inches), 1 lock washer, 1 nut (1/2 inch), 1 bolt (3/8 x 1-1/4 inches), and 1 nut (3/8 inch) as shown in [Figure 3](#).

Note: You may need to loosen the 3 baffle bolts when you install the blower mount to align the assembly with the deck. Tighten the bolts after installing the mount.

2. Remove the top nut, washer, and sheave from the spindle ([Figure 6](#)).

Note: Note the orientation of the sheave when you remove it from the spindle to ensure that you install it properly later in the process.

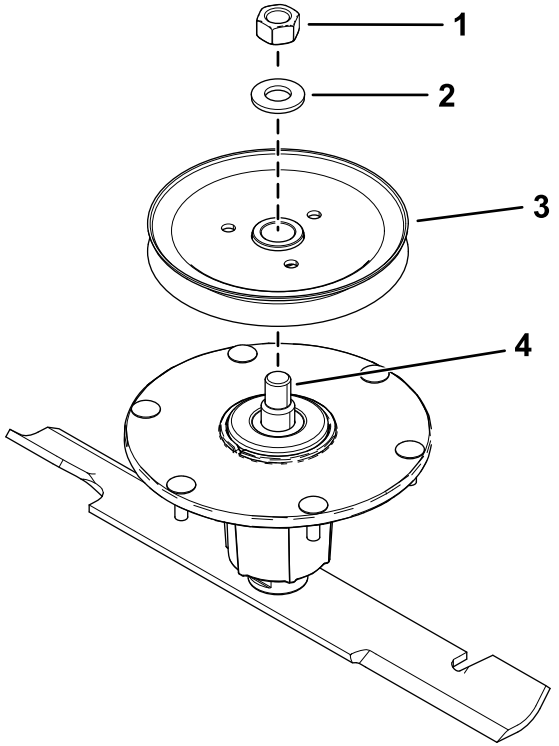

g302393

Figure 6

- | | |
|------------|------------|
| 1. Top nut | 3. Sheave |
| 2. Washer | 4. Spindle |

3. Insert the pulley-plate mount studs into the holes in the sheave ([Figure 7](#)).

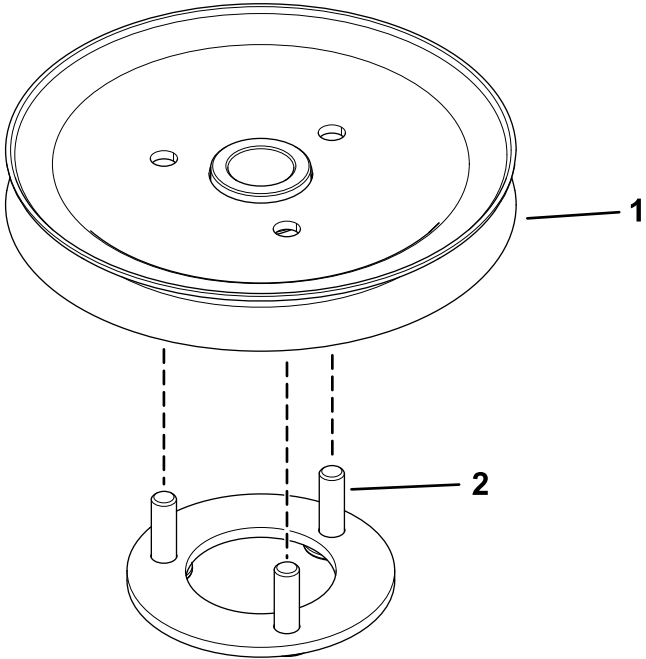

g302390

Figure 7

- | | |
|-----------|-----------------------------|
| 1. Sheave | 2. Pulley-plate mount studs |
|-----------|-----------------------------|

- Loosely install the 3 nuts to the studs (Figure 8). Leave a clearance of 5 mm (3/16 inch) between the nut and sheave.

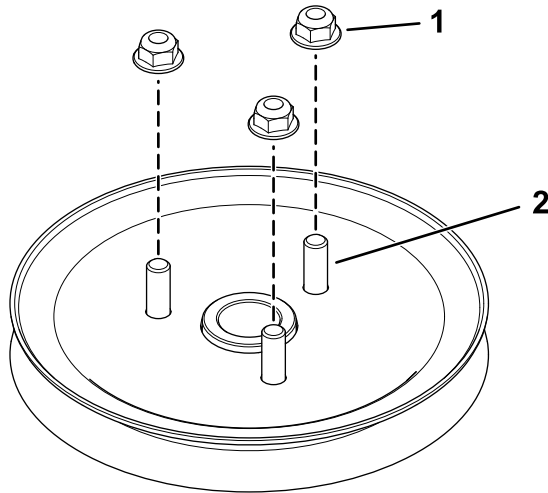

Figure 8

g302412

1. Nut

2. Stud

- Install the sheave assembly to the spindle using the washer and top nut (Figure 9).

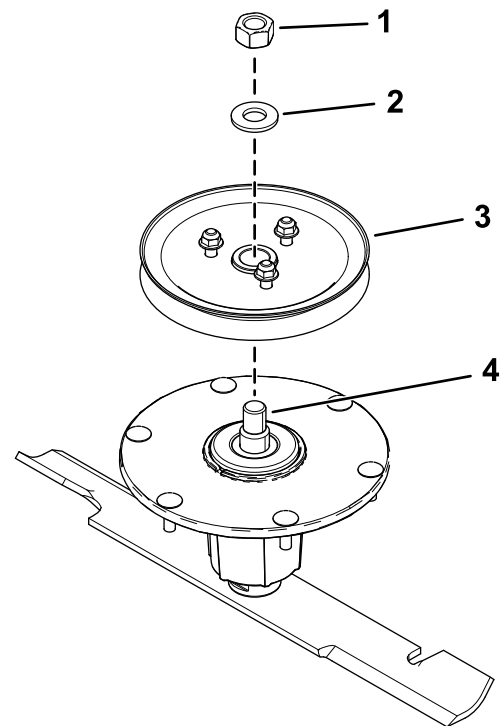

Figure 9

g302413

- Top nut
- Washer
- Sheave assembly
- Spindle

- Torque the top nut to 176 to 217 N·m (130 to 160 ft-lb).

Note: Ensure that the sheave spins freely.

- Align the new pulley assembly so that the openings fit over the nuts (Figure 10).

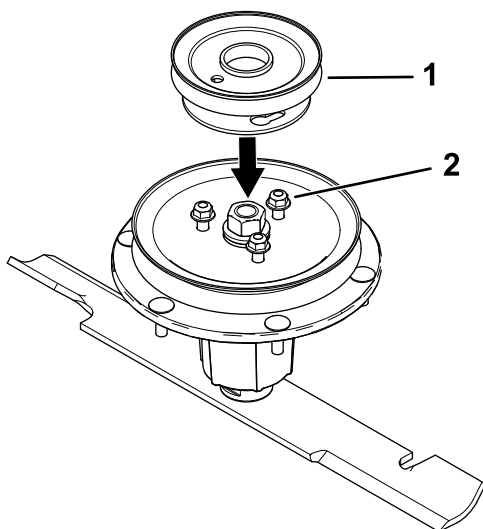

Figure 10

g302411

- Pulley assembly
- Nuts

- Turn the pulley to lock it into position (Figure 11).

Note: If the pulley does not turn, loosen the nuts more to raise the nuts and allow the pulley to lock into position.

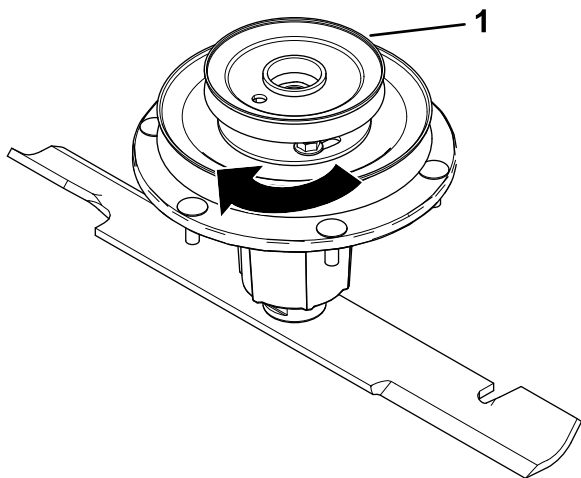

Figure 11

g302414

- Pulley assembly

- After the new pulley assembly is in position, tighten the nuts to secure new pulley assembly. Torque the 3 nuts to 28 to 34 N·m (21 to 25 ft-lb).
- Using the 3 nuts that you removed previously, 1 carriage bolt (3/8 x 1-1/4 inches), and 2 carriage bolts (3/8 x 1 inch), install the idler assembly to the mower deck (Figure 5).
- Install the deck belt.

5

Installing the Blower Assembly, Belt, and Belt Cover

Parts needed for this procedure:

1	Blower assembly
1	Belt
1	Belt cover
1	Knob
1	Hose
1	Hose clamp

Procedure

Refer to the bagger *Operator's Manual* for the correct procedure to install the blower assembly, belt, and belt covers.

Notes:

Notes:

California Proposition 65 Warning Information

What is this warning?

You may see a product for sale that has a warning label like the following:



WARNING: Cancer and Reproductive Harm—www.p65Warnings.ca.gov.

What is Prop 65?

Prop 65 applies to any company operating in California, selling products in California, or manufacturing products that may be sold in or brought into California. It mandates that the Governor of California maintain and publish a list of chemicals known to cause cancer, birth defects, and/or other reproductive harm. The list, which is updated annually, includes hundreds of chemicals found in many everyday items. The purpose of Prop 65 is to inform the public about exposure to these chemicals.

Prop 65 does not ban the sale of products containing these chemicals but instead requires warnings on any product, product packaging, or literature with the product. Moreover, a Prop 65 warning does not mean that a product is in violation of any product safety standards or requirements. In fact, the California government has clarified that a Prop 65 warning "is not the same as a regulatory decision that a product is 'safe' or 'unsafe.'" Many of these chemicals have been used in everyday products for years without documented harm. For more information, go to <https://oag.ca.gov/prop65/faqs-view-all>.

A Prop 65 warning means that a company has either (1) evaluated the exposure and has concluded that it exceeds the "no significant risk level"; or (2) has chosen to provide a warning based on its understanding about the presence of a listed chemical without attempting to evaluate the exposure.

Does this law apply everywhere?

Prop 65 warnings are required under California law only. These warnings are seen throughout California in a wide range of settings, including but not limited to restaurants, grocery stores, hotels, schools, and hospitals, and on a wide variety of products. Additionally, some online and mail order retailers provide Prop 65 warnings on their websites or in catalogs.

How do the California warnings compare to federal limits?

Prop 65 standards are often more stringent than federal and international standards. There are various substances that require a Prop 65 warning at levels that are far lower than federal action limits. For example, the Prop 65 standard for warnings for lead is 0.5 µg/day, which is well below the federal and international standards.

Why don't all similar products carry the warning?

- Products sold in California require Prop 65 labelling while similar products sold elsewhere do not.
- A company involved in a Prop 65 lawsuit reaching a settlement may be required to use Prop 65 warnings for its products, but other companies making similar products may have no such requirement.
- The enforcement of Prop 65 is inconsistent.
- Companies may elect not to provide warnings because they conclude that they are not required to do so under Prop 65; a lack of warnings for a product does not mean that the product is free of listed chemicals at similar levels.

Why does Toro include this warning?

Toro has chosen to provide consumers with as much information as possible so that they can make informed decisions about the products they buy and use. Toro provides warnings in certain cases based on its knowledge of the presence of one or more listed chemicals without evaluating the level of exposure, as not all the listed chemicals provide exposure limit requirements. While the exposure from Toro products may be negligible or well within the "no significant risk" range, out of an abundance of caution, Toro has elected to provide the Prop 65 warnings. Moreover, if Toro does not provide these warnings, it could be sued by the State of California or by private parties seeking to enforce Prop 65 and subject to substantial penalties.