



Count on it.

Operator's Manual

**Multi Pro[®] 5800-D Turf Sprayer
with ExcelaRate Spray System**

Model No. 41393—Serial No. 40000000 and Up

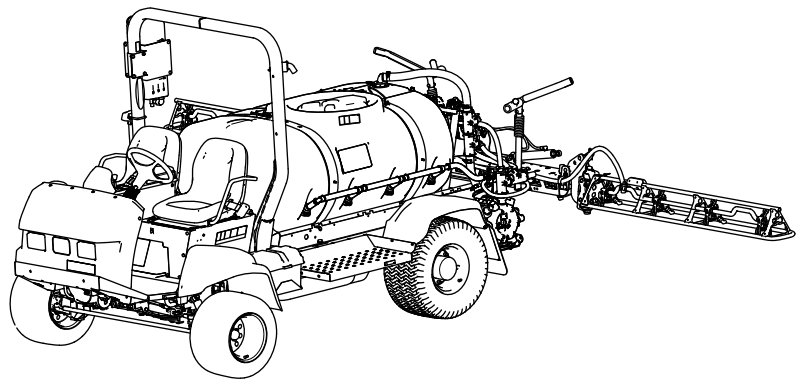

The Multi Pro® turf sprayer is a dedicated turf spray application vehicle and is intended to be used by professional, hired operators in commercial applications. It is primarily designed for spraying on well-maintained lawns in parks, golf courses, sports fields, and on commercial grounds.

This product complies with all relevant European directives; for details, please see the separate product specific Declaration of Conformity (DOC) sheet.

It is a violation of California Public Resource Code Section 4442 or 4443 to use or operate the engine on any forest-covered, brush-covered, or grass-covered land unless the engine is equipped with a spark arrester, as defined in Section 4442, maintained in effective working order or the engine is constructed, equipped, and maintained for the prevention of fire.

The enclosed *Engine Owner's Manual* is supplied for information regarding the US Environmental Protection Agency (EPA) and the California Emission Control Regulation of emission systems, maintenance, and warranty. Replacements may be ordered through the engine manufacturer.

⚠ WARNING

**CALIFORNIA
Proposition 65 Warning**

Diesel engine exhaust and some of its constituents are known to the State of California to cause cancer, birth defects, and other reproductive harm.

Use of this product may cause exposure to chemicals known to the State of California to cause cancer, birth defects, or other reproductive harm.

Introduction

Read this manual carefully to learn how to operate and maintain your product properly. The information in this manual can help you and others avoid injury and product damage. Although Toro designs and produces safe products, you are responsible for operating the product properly and safely. You may contact Toro directly at www.Exmark.com for product safety and operation training materials, accessory information, help finding a dealer, or to register your product.

Whenever you need service, genuine Toro parts, or additional information, contact an Authorized Service

Dealer or Toro Customer Service and have the model and serial numbers of your product ready. [Figure 1](#) illustrates the location of the model and serial numbers on the product.

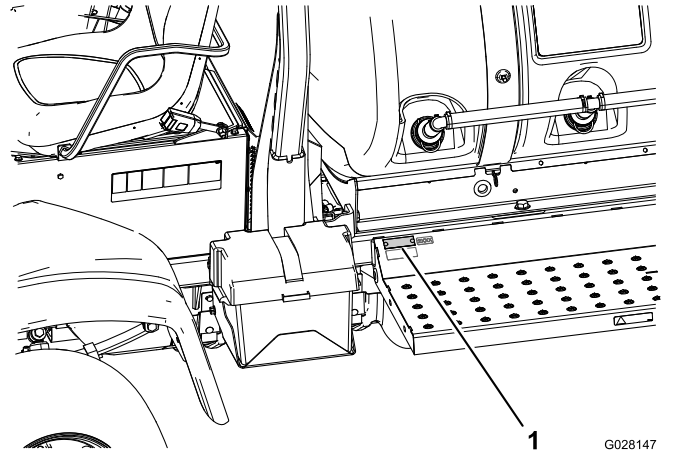

Figure 1

1. Location of the model and serial numbers

<p>Model No. _____</p> <p>Serial No. _____</p>
--

This manual identifies potential hazards and has safety messages identified by the safety-alert symbol ([Figure 2](#)), which signals a hazard that may cause serious injury or death if you do not follow the recommended precautions.



Figure 2

1. Safety-alert symbol

This manual uses 2 words to highlight information. **Important** calls attention to special mechanical information and **Note** emphasizes general information worthy of special attention.

Contents

Safety	4	Greasing the Front Steering and Suspension	51
General Safety	4	Greasing the Boom Hinges	51
Safe Operating Practices	4	Greasing the Actuator-Rod Bearings	52
Chemical Safety	5	Engine Maintenance	53
Operating	6	Checking the Air Cleaner	53
Maintenance	7	Servicing the Engine Oil	55
Safety and Instructional Decals	8	Fuel System Maintenance	57
Setup	15	Checking the Fuel Line and Connections	57
1 Checking the Boom-Hinge Springs	15	Bleeding the Fuel System	57
2 Assembling the Sprayer Tank Fill Fitting	16	Bleeding Air from the Injectors	58
3 Removing the Shipping Bumper	17	Servicing the Fuel Filters	59
Product Overview	18	Draining the Fuel Tank	60
Controls	19	Electrical System Maintenance	61
Engine Warning and Indication Lights	21	Replacing the Fuses	61
Sprayer Controls	22	Servicing the Battery	61
Specifications	25	Drive System Maintenance	63
Operation	25	Inspecting the Wheels/Tires	63
Think Safety First	25	Changing the Planetary-Gearbox Fluid	63
Performing Pre-Starting Checks	25	Adjusting the Front Wheel Toe-in	64
Preparing to Drive the Machine	25	Cooling System Maintenance	65
Preparing to Use the Sprayer	27	Servicing the Cooling System	65
Operating the Machine	29	Brake Maintenance	67
Breaking in a New Sprayer	30	Adjusting the Brakes	67
Operating the Sprayer	30	Belt Maintenance	67
Filling the Fresh-Water Tank	30	Servicing the Alternator Belt	67
Filling the Spray Tank	31	Hydraulic System Maintenance	68
Operating the Spray Sections	32	Checking the Hydraulic Fluid	68
Sprayer Functions for Application Rate Mode and Manual Mode	32	Servicing the Hydraulic System	69
Spraying with the ExcelaRate Sprayer System	32	Spray System Maintenance	71
Taking Proper Turf Care Precautions while Operating in Stationary Modes	36	Inspecting the Hoses	71
Spraying Tips	36	Changing the Suction Filter	71
Unclogging a Nozzle	36	Changing the Pressure Filter	72
Selecting a Nozzle	37	Changing the Nozzle Filter	72
Cleaning the Sprayer System	37	Adjusting the Booms to Level	73
Setting the Section-Bypass Valves	38	Inspecting the Nylon Pivot Bushings	73
Agitation-Bypass Valve Knob Position	39	Pump Maintenance	74
Calibrating the Agitation-Bypass Valve	39	Inspecting the Pump	74
Locating the Spray Pump	40	Cleaning	75
Hauling the Machine	40	Cleaning the Radiator-Cooling Fins	75
Transporting the Sprayer	40	Cleaning the Flow meter	75
Towing the Sprayer	41	Cleaning the Agitation and Section Valves	75
Spray Filter Recommendations	42	Storage	83
Maintenance	45	Troubleshooting	85
Recommended Maintenance Schedule(s)	45	Schematics	88
Daily Maintenance Checklist	47		
Notation for Areas of Concern	47		
Pre-Maintenance Procedures	48		
Raising the Sprayer	48		
Accessing the Engine	48		
Lubrication	51		
Greasing the Spray Pump	51		

Safety

Improper use or maintenance by the operator or owner can result in injury. To reduce the potential for injury, comply with these safety instructions and always pay attention to the safety-alert symbol (Figure 2), which means *Caution, Warning, or Danger*—personal safety instruction. Failure to comply with the instruction may result in personal injury or death.

This machine has been designed in accordance with SAE J2258.

General Safety

This product is capable of causing personal injury. Always follow all safety instructions to avoid serious personal injury.

- Read and understand the contents of this *Operator's Manual* before starting the engine.
- Use your full attention while operating the machine. Do not engage in any activity that causes distractions; otherwise, injury or property damage may occur.
- Use appropriate personal protective equipment (PPE) to guard against contact with chemicals. Chemical substances used in the sprayer system may be hazardous and toxic.
- Do not put your hands or feet near moving components of the machine.
- Do not operate the machine without all guards and other safety protective devices in place and working on the machine.
- Keep clear of any discharge area of the sprayer nozzles and spray drift. Keep bystanders and children out of the operating area.
- Never allow children to operate the machine.
- Shut off the engine, remove the key (if equipped), and wait for all movement to stop before you leave the operator's position. Allow the machine to cool before adjusting, servicing, cleaning, or storing it.

Improperly using or maintaining this machine can result in injury. To reduce the potential for injury, comply with these safety instructions and always pay attention to the safety-alert symbol ▲, which means *Caution, Warning, or Danger*—personal safety instruction. Failure to comply with these instructions may result in personal injury or death.

Not all the attachments that adapt to this machine are covered in this manual. Refer to the operator's manual provided with each attachment for additional safety instructions.

Safe Operating Practices

Important: Important: The machine is designed primarily as an off-road vehicle and is not intended for extensive use on public roads. When using the machine on public roads, follow all traffic regulations and use any additional accessories that may be required by law, such as lights, turn signals, slow moving vehicle (SMV) sign, and others as required.

The Multi Pro® 5800 Turf Sprayer was designed and tested to offer safe service when operated and maintained properly. Although hazard control and accident prevention partially are dependent upon the design and configuration of the machine, these factors are also dependent upon the awareness, concern, and proper training of the personnel involved in the operation, maintenance and storage of the machine. Improper use or maintenance of the machine can result in injury or death.

Not all of the attachments that adapt to the Multi Pro®5800 Turf Sprayer are covered in this manual. See the specific operator's manual provided with each attachment for additional safety instructions.

To reduce the potential for injury or death, comply with the following safety instructions:

Supervisor's Responsibilities

- Make sure that operators are thoroughly trained and familiar with the *Operator's Manual*, engine owner's manual, and all labels on the sprayer.
- Establish your own special procedures and work rules for unusual operating conditions (e.g., slopes too steep for machine operation).

Training

- Read the *Operator's Manual* and other training material before operating the machine.
- Note:** If the operator(s) or mechanic(s) cannot read the manual language, it is the owner's responsibility to explain this material to them.
- Become familiar with the safe operation of the equipment, operator controls, and safety signs.
 - All operators and mechanics should be trained. The owner is responsible for training the users.
 - Never allow untrained people to operate or service the equipment.
- Note:** Local regulations may restrict the age of the operator.
- The owner/operator can prevent and is responsible for accidents or injuries occurring to themselves, other people, or damage to property.

Before Operating

- Operate the machine only after reading and understanding the contents of this manual.
- **Never** allow children to operate the machine.
- **Never** allow other adults to operate the machine without first reading and understanding the *Operator's Manual*. Only trained and authorized persons should operate this machine. Make sure that all operators are physically and mentally capable of operating the machine.
- This machine is designed to carry the operator and **1 passenger** in the seat provided by the manufacturer. **Never** carry any additional passengers on the machine.
- **Never** operate the machine while you are ill, tired, or under the influence of alcohol or drugs.
- Become familiar with the controls and know how to shutoff the engine quickly.
- Keep all shields, safety devices, and decals in place. If a shield, safety device, or decal is malfunctioning, illegible, or damaged, repair or replace it before operating the machine.
- Wear appropriate clothing; including safety glasses, long pants, substantial slip-resistant footwear or rubber boots, gloves, and hearing protection. Do not wear jewelry or loose clothing. Tie back long hair.

⚠ CAUTION

This machine produces sound levels in excess of 85 dBA at the operator's ear and can cause hearing loss through extended periods of exposure.

Wear hearing protection when operating this machine.

- Operate only in daylight or good artificial light.
- Never spray while people, especially children or pets are nearby.
- Before operating the machine, always check the designated areas of the sprayer that are stated in the [Performing Pre-Starting Checks \(page 25\)](#) in the [Operation \(page 25\)](#) section. If the machine does not function correctly or is damaged in any way, do **not** use the sprayer. Make sure that the problem is corrected before the sprayer or attachment is operated.
- Make sure that the operator and passenger areas are clean and free from chemical residue and debris buildup.
- Ensure that all fluid line connectors are tight and all hoses are in good condition before applying pressure to the system.

Note: Do not use the sprayer if it is leaking or damaged.

Chemical Safety

⚠ WARNING

Chemical substances used in the spreader-sprayer system may be hazardous and toxic to you, bystanders, animals, plants, soils or other property.

- **Carefully read and follow the chemical warning labels and material safety data sheets (MSDS) for all chemicals used and protect yourself according to the chemical manufacturer's recommendations. Ensure that as little skin as possible is exposed while using chemicals. Use appropriate personal protective equipment (PPE) to guard against personal contact with chemicals, such as:**
 - safety glasses, goggles, and/or face shield
 - respirator or filter mask
 - chemical resistant gloves
 - rubber boots or other substantial footwear
 - hearing protection
 - clean change of clothes, soap, and disposable towels, to be kept on-hand, in the event of a chemical spill.
- **Keep in mind that there may be more than 1 chemical used, and information on each chemical should be assessed.**
- **Refuse to operate or work on the sprayer if this information is not available!**
- **Before working on a sprayer system, make sure that the system has been triple rinsed and neutralized according to the recommendations of the chemical manufacturer(s) and all of the valves have been cycled 3 times.**
- **Verify there is an adequate supply of clean water and soap nearby, and immediately wash off any chemicals that contact you.**
- Obtain proper training before using or handling chemicals.
- Use the correct chemical for the job.

- Follow the chemical manufacturer's instructions for the safe application of the chemical. Do not exceed recommended system application pressure.
 - Do not fill, calibrate, or clean the unit when people, especially children, or pets are in the area.
 - Handle chemicals in a well ventilated area.
 - Have clean water available especially when filling the spray tank.
 - Do not eat, drink, or smoke while working with chemicals.
 - Do not clean spray nozzles by blowing through them or placing in mouth.
 - Always wash your hands and other exposed areas as soon as possible after you finish working with chemicals.
 - Keep chemicals in their original packages and stored in a safe location.
 - Properly dispose of unused chemicals and chemical containers as instructed by the chemical manufacturer and your local codes.
 - Chemicals and fumes are dangerous; never enter the tank or place your head over or in the opening of a tank.
 - Follow all local, state, federal regulations for spreading or spraying chemicals.
- at higher speeds, or with a full load. Stopping time and distance will increase with a full load.
 - Avoid sudden stops and starts. Do not go from reverse to forward or forward to reverse without first coming to a complete stop.
 - Slow down before turning. Do not attempt sharp turns or abrupt maneuvers or other unsafe driving actions that may cause a loss of sprayer control.
 - Before backing up, look to the rear and ensure that no one is behind you. Back up slowly.
 - Watch out for traffic when you are near or crossing roads. Always yield the right of way to pedestrians and other vehicles. This sprayer is **not** designed for use on streets or highways. Always signal your turns or stop early enough so that other people know what you plan to do. Obey all traffic rules and regulations.
 - The electrical and exhaust systems of the sprayer can produce sparks capable of igniting explosive materials. Never operate the sprayer in or near an area where there is dust or fumes in the air which are explosive.
 - If you are ever unsure about safe operation, **stop work** and ask your supervisor.
- Do not touch the engine or muffler while the engine is running or soon after it has shut off. These areas may be hot enough to cause burns.
 - If the machine ever vibrates abnormally, stop immediately, wait for all motion to stop, and inspect the machine for damage. Repair all damage before resuming operation.
 - Before getting off the seat:
 1. Stop the machine.
 2. Remove your foot from the traction pedal and engage the parking brake.
 3. Turn the key for the starter switch to the OFF position.
 4. Remove the key from the starter switch.

Operating

⚠ WARNING

Engine exhaust contains carbon monoxide, which is an odorless, deadly poison that can kill you.

Do not run engine indoors or in an enclosed area.

- The operator (and passenger) should remain seated whenever the sprayer is in motion. The operator should keep both hands on the steering wheel whenever possible. Keep your arms and legs within the operator's compartment at all times.
 - Failure to operate the machine safely may result in an accident, tip over of the sprayer, and serious injury or death. Drive carefully. To prevent tipping or loss of control:
 - Use extreme caution, reduce speed, and maintain a safe distance around sand traps, ditches, creeks, ramps, unfamiliar areas, or any areas that have abrupt changes in ground conditions or elevation.
 - Watch for holes or other hidden hazards.
 - Use extra caution when operating the machine on wet surfaces, in adverse weather conditions,
- Lightning can cause severe injury or death. If lightning is seen in the area, do not operate the machine; seek shelter.

Braking

- Slow down before you approach an obstacle. This gives you extra time to stop or turn away. Hitting an obstacle can damage the machine and its contents. More important, it can injure you.
- Gross vehicle weight (GVW) has a major impact on your ability to stop and/or turn. Heavy loads and attachments make a machine harder to stop

or turn. The heavier the load, the longer it takes to stop.

- Turf and pavement are much more slippery when they are wet. It can take 2 to 4 times as long to stop on wet surfaces as on dry surfaces. If you drive through standing water deep enough to get the brakes wet, they will not work well until they are dry. After driving through water, you should test the brakes to make sure that they work properly. If they do not, drive slowly while putting light pressure on the brake pedal. This will dry the brakes out.

ROPS Safety

Note: For each machine covered in this *Operator's Manual*, a cab installed by Toro is a ROPS.

- Do not remove the ROPS from the machine.
- Fasten the seat belt and ensure that you can release it quickly in an emergency. Always wear your seat belt when the roll bar is up or on a machine with a cab installed by Toro.
- Check carefully for overhead obstructions and do not contact them.
- Keep the ROPS in safe operating condition by thoroughly inspecting it periodically for damage and keeping all the mounting fasteners tight.
- Replace any damaged ROPS component. Do not repair or alter it.

Operating on Hills and Rough Terrain

Operating the machine on a hill may cause tipping or rolling of the machine, or the engine may stall and you could lose headway on the hill. This could result in personal injury.

- Do not accelerate quickly or suddenly apply the brakes when backing down a hill, especially with a load.
- Never drive across a steep hill; always drive straight up or down or go around the hill.
- If the engine stalls or you begin to lose headway while climbing a hill, gradually apply the brakes and slowly back straight down the hill.
- Turning while traveling up or down hills can be dangerous. If you have to turn while on a hill, do it slowly and cautiously. Never make sharp or fast turns.
- Heavy loads affect stability. Reduce the weight of the load and your speed when operating on hills.
- Avoid stopping on hills, especially with a load. Stopping while going down a hill takes longer than stopping on level ground. If you must stop the machine, avoid sudden speed changes, which

may initiate tipping or rolling of the machine. Do not suddenly apply the brakes when rolling backward, as this may cause the machine to overturn.

- Reduce speed and load when operating on rough terrain, uneven ground, and near curbs, holes, and other sudden changes in terrain. Loads may shift, causing the machine to become unstable.

▲ WARNING

Sudden changes in terrain may cause abrupt steering wheel movement, possibly resulting in hand and arm injuries.

Grip the steering wheel loosely around the perimeter. Keep your hands clear of the steering wheel spokes.

Loading

The weight of the cargo can change the center of gravity of the machine and the handling of it. To avoid loss of control and personal injury, follow these guidelines:

- Liquid loads can shift. This shifting happens most often while turning, going up or down hills, suddenly changing speeds, or while driving over rough surfaces. Shifting loads can cause the machine to tip over.
- When operating with a heavy load, reduce your speed and allow for sufficient braking distance. Do not suddenly apply the brakes. Use extra caution on slopes.
- Be aware that heavy loads increase your stopping distance and reduce your ability to turn quickly without tipping over.

Maintenance

- Only permit qualified and authorized personnel to maintain, repair, adjust, or inspect the machine.
- Before performing any maintenance, ensure that the system has been thoroughly rinsed and cleaned.
- Before servicing or making adjustments to the machine, shutoff the engine, engage the parking brake, and remove the key to prevent someone from accidentally starting the engine.
- To make sure that the entire machine is in good condition, keep all nuts, bolts, and screws properly tightened.
- To reduce the potential for fire, keep the engine area free of excessive grease, grass, leaves, and accumulation of dirt.
- Never use an open flame to check the level or leakage of fuel or battery electrolyte.

- If you must run the engine to perform a maintenance adjustment, keep your hands, feet, clothing, and any parts of your body away from the engine and any moving parts. Keep everyone away.
- Do not use open pans of fuel or flammable cleaning fluids when cleaning parts.
- **Do not adjust** the traction control speed. To ensure safety and accuracy, have an Authorized Toro Distributor check the ground speed.
- Keep your body and hands away from pinhole leaks or nozzles that eject high-pressure fluid. Use cardboard or paper to find leaks. Fluid escaping

under pressure can penetrate skin and cause injury requiring surgery within a few hours by a qualified surgeon; otherwise, gangrene may result.

- If major repairs are ever needed or assistance is required, contact an Authorized Toro Distributor.
- To be sure of optimum performance and safety, always purchase genuine Toro replacement parts and accessories. Replacement parts and accessories made by other manufacturers could be dangerous. Altering this machine in any manner that may affect machine operation, performance, durability, or its use, may result in injury or death. Such use could void the product warranty.

Safety and Instructional Decals



Safety decals and instructions are easily visible to the operator and are located near any area of potential danger. Replace any decal that is damaged or missing.



93-6686

decal93-6686

1. Hydraulic fluid

2. Read the *Operator's Manual*.



106-6755

decal106-6755

1. Engine coolant under pressure.

3. Warning—do not touch the hot surface.

2. Explosion hazard—read the *Operator's Manual*.

4. Warning—read the *Operator's Manual*.



106-5517

decal106-5517

1. Warning—do not touch the hot surface.

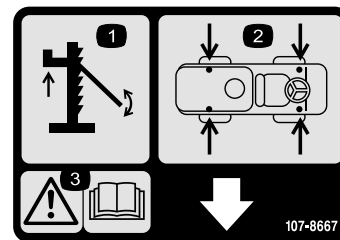

107-8667

decal107-8667

1. Jacking

2. Jack-point locations

3. Warning—Read the *Operator's Manual* for more information on jacking the vehicle

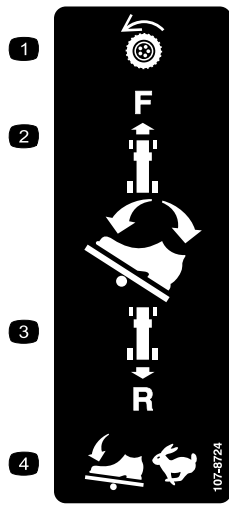

107-8724

decal107-8724

1. Traction drive
2. To drive forward, press the top of the traction pedal forward and down.
3. To drive in reverse, press the bottom of the pedal rearward and down.
4. Vehicle speed increases with more pedal pressure.

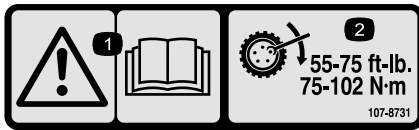

107-8731

decal107-8731

1. Warning—read the *Operator's Manual*.
2. Torque the lug nuts to 75 to 102 N·m (55 to 75 ft-lb).

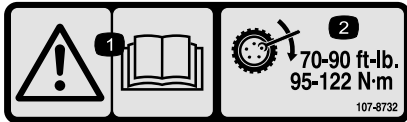

107-8732

decal107-8732

1. Warning—read the *Operator's Manual*.
2. Torque the lug nuts to 95 to 122 N·m (75 to 90 ft-lb).

CALIFORNIA SPARK ARRESTER WARNING

Operation of this equipment may create sparks that can start fires around dry vegetation. A spark arrester may be required. The operator should contact local fire agencies for laws or regulations relating to fire prevention requirements.

117-2718

117-2718

decal117-2718



117-4955

decal117-4955

1. Warning—read the *Operator's Manual*; wear the seat belt when seated in the operator's position; avoid tipping the machine.
2. Warning—wear hearing protection.

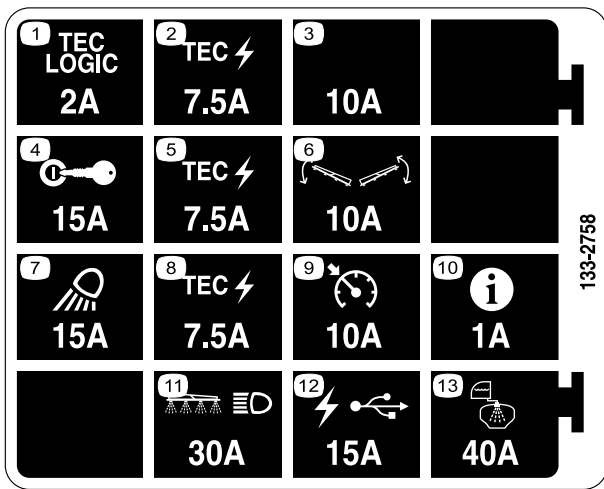

133-2758

decal133-2758

- | | |
|-------------------------|-----------------------------|
| 1. Tec Logic—2 A | 8. Tec power—7.5 A |
| 2. Tec power—7.5 A | 9. Cruise control—10 A |
| 3. Extra fuse slot—10 A | 10. InfoCenter—1 A |
| 4. Ignition—15 A | 11. Boom and headlight—30 A |
| 5. Tec power—7.5 A | 12. USB power—15 A |
| 6. Boom control—10 A | 13. Tank spray—40 A |
| 7. Work light—15 A | |

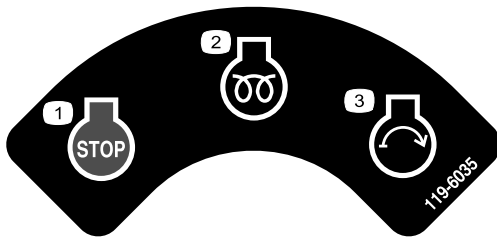

119-6035

decal119-6035

- | | |
|------------------------|-----------------|
| 1. Engine—stop | 3. Engine—start |
| 2. Engine—run, preheat | |

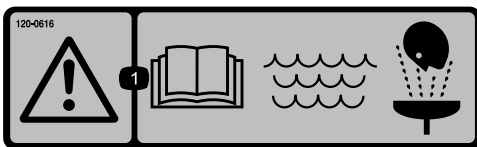

120-0616

decal120-0616

- Warning—read the *Operator's Manual*; use fresh, clean water for first-aid washing.



120-0622

decal120-0622

- Warning—read the *Operator's Manual*.
- Warning—do not enter the tank.
- Caustic liquid/chemical burn and toxic gas inhalation hazards—wear hand, skin, eye, and respiratory protection.

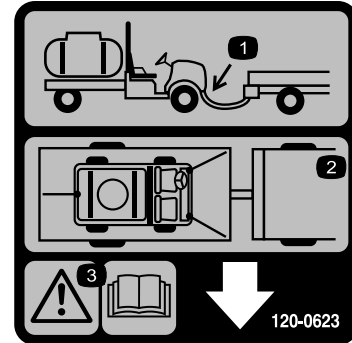

120-0623

decal120-0623

- Tow hitch location
- Tie down locations
- Warning—Read the *Operator's Manual*.

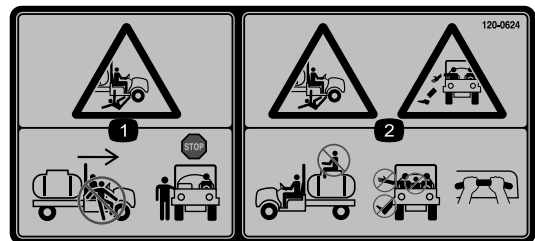

120-0624

decal120-0624

- Crushing/dismemberment hazard of bystanders—do not exit or enter the machine while it is moving; stop the machine before entering or exiting.
- Falling, crushing hazard—no riders on tank; keep arms and legs inside of the vehicle at all times, use passenger hand holds.

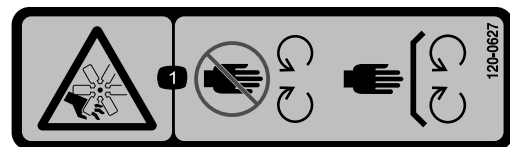

120-0627

decal120-0627

- Cutting/dismemberment hazard, fan—stay away from moving parts; keep all guards and shields in place.

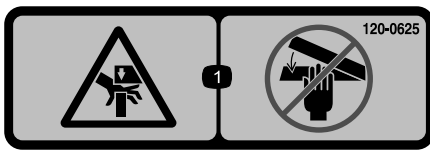

120-0625

decal120-0625

1. Pinch point, hand—keep hands away.



120-0617

decal120-0617

1. Pinch point—keep hands away from the hinge.
2. Crushing hazard, boom—keep bystanders away.



127-6976

decal127-6976

1. Decrease
2. Increase

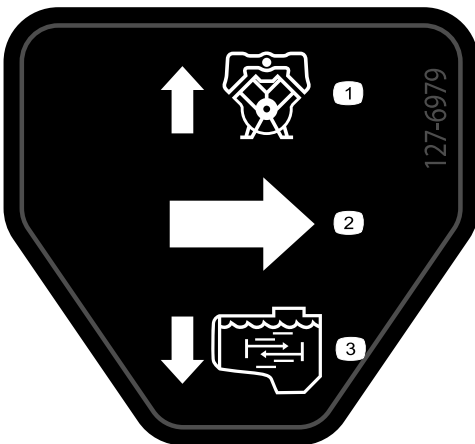

127-6979

decal127-6979

1. Pump-return flow
2. Flow
3. Agitation flow

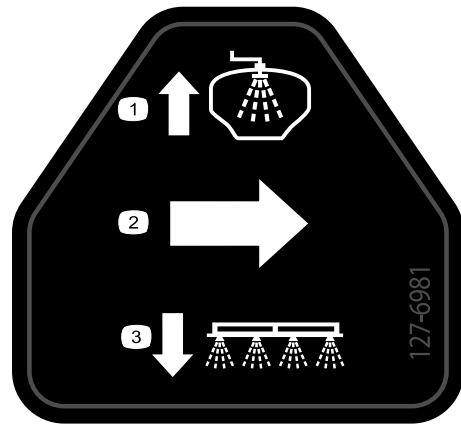

127-6981

decal127-6981

1. Bypass-return flow
2. Flow
3. Section spray

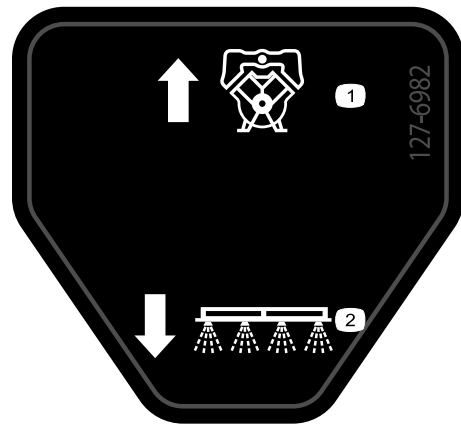

127-6982

decal127-6982

1. Pump-return flow
2. Section spray

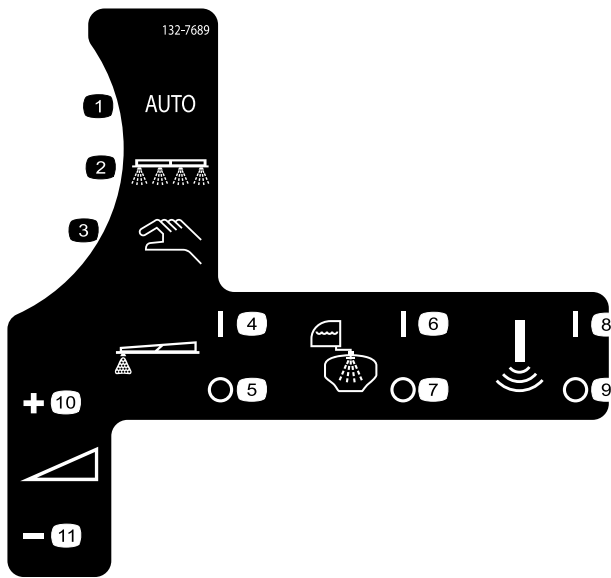

132-7689

decal132-7689

1. Auto spray mode
2. Spray mode
3. Manual spray mode
4. Foam marker—on
5. Foam marker—off
6. Rinse system—on
7. Rinse system—off
8. Sonic sensor—on
9. Sonic sensor—off
10. Application rate—increase
11. Application rate—decrease

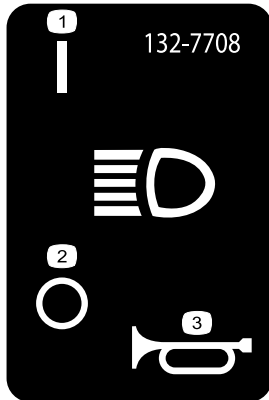

132-7708

decal132-7708

1. Headlight—on
2. Headlight—off
3. Horn

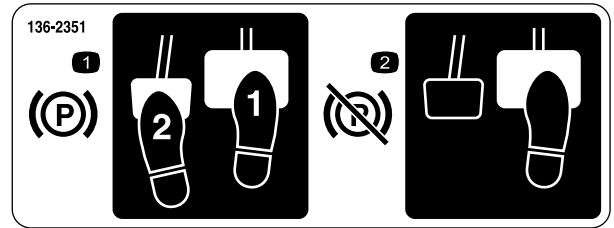

136-2351

decal136-2351

1. To engage the parking brake, press down the brake and parking-brake pedal.
2. To disengage the parking brake, press and release the parking-brake pedal.

MULTIPRO 5800 QUICK REFERENCE AID

CHECK/SERVICE

1. ENGINE OIL DIP STICK
2. ENGINE OIL FILL
3. ENGINE OIL DRAIN
4. ENGINE OIL FILTER
5. HYDRAULIC OIL STRAINER
6. HYDRAULIC OIL DIP STICK
7. HYDRAULIC OIL FILTER (2)
8. TRANSHYD OIL DRAIN
9. FUEL FILL
10. FUEL FILTER
11. AIR FILTER
12. BATTERY
13. TIRE PRESSURE: +20 PSI/FRONT +20 PSI/REAR
14. RADIATOR CLEAN OUT ACCESS
15. PLANETARY GEAR
16. SUCTION FILTER
17. PRESSURE FILTER
- 17x GREASE POINTS (100 HRS)

FLUID SPECIFICATIONS / CHANGE INTERVALS

SEE OPERATOR'S MANUAL FOR INITIAL CHANGES	FLUID TYPE	CAPACITY	CHANGE INTERVALS
		L	QT
ENGINE OIL	SEE MANUAL	4.2	4.9
TRANSHYDRAULIC OIL	SEE MANUAL	59	60
FUEL	SEE MANUAL	45.4	48
RADIATOR		5.5	5.8
AIR CLEANER	CLEAN EVERY 50 HRS.		100 HRS.
PLANETARY GEAR BOX		1.2	1.4
SUCTION FILTER	CLEAN DAILY		400 HRS.
PRESSURE FILTER	CLEAN DAILY		400 HRS.

1 HEAVY DUTY OPERATION; MAINTENANCE SHOULD BE PERFORMED TWICE AS FREQUENTLY.

THE TORO COMPANY
8111 Lyndale Avenue South
Bloomington, MN 55420-1196 USA

136-2257

decal136-2257

1. Read the *Operator's Manual*.

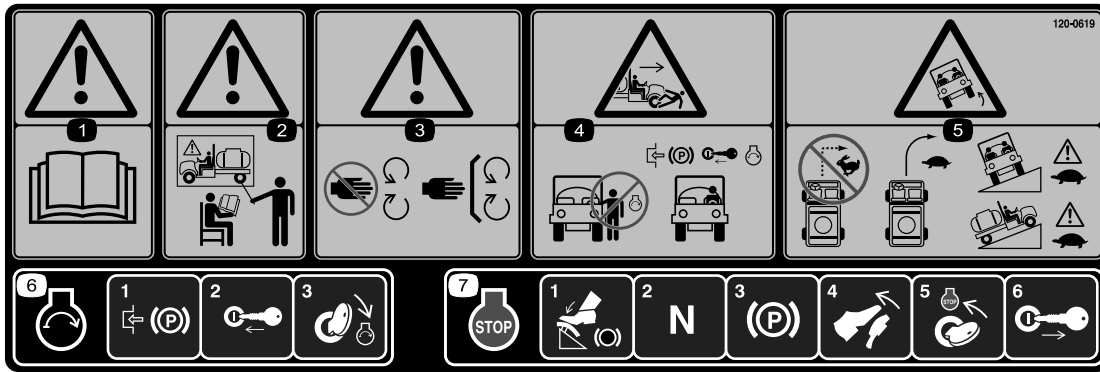

decal120-0619

120-0619

1. Warning—read the *Operator's Manual*.
2. Warning—do not operate this machine unless you are trained.
3. Warning—stay away from moving parts, keep all guards and shields in place.
4. Crushing/dismemberment hazard of bystanders—do not start the engine while entering or exiting the vehicle; engage the parking brake, insert the key, and start the engine while seated in the operator's seat.
5. Tipping hazard—do not turn sharply while traveling fast, drive slowly when turning; use caution and drive slowly when traveling across or up and down slopes.
6. To start the engine, engage the parking brake, insert the ignition key and turn it to the start position.
7. To shut off the engine, press the brake, ensure that the traction pedal is in the Neutral position, engage the parking brake, release the brake, turn the key to the STOP position, and remove the key.



decal132-7786

132-7786

1. Spray—off
2. Spray—on
3. USB

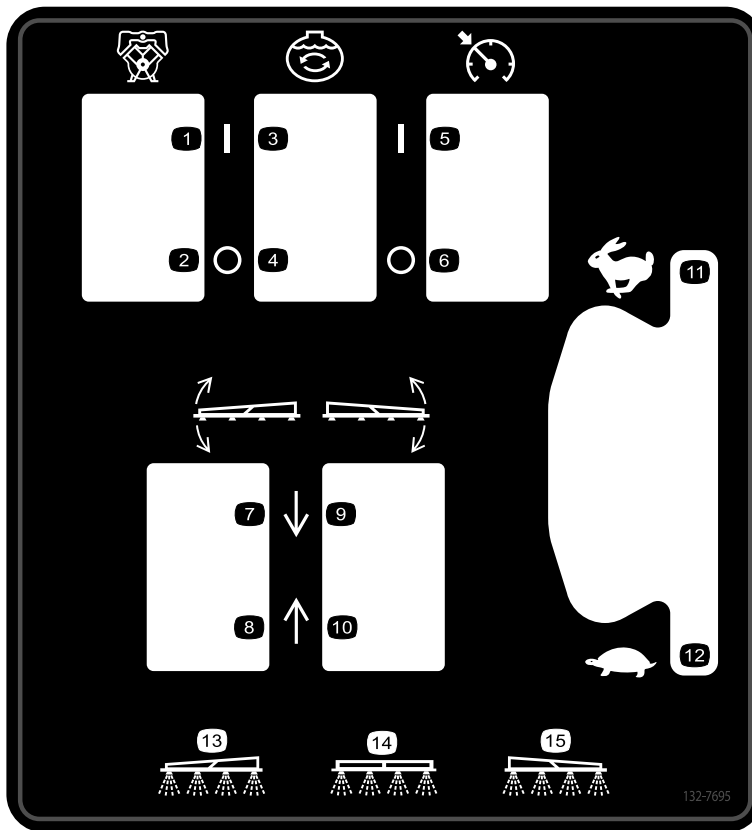

decal132-7695

132-7695

- | | | | |
|------------------|----------------------------|------------------------------|--------------------------|
| 1. Pump—on | 5. Speed control—on | 9. Lower the right section. | 13. Left section spray |
| 2. Pump—off | 6. Speed control—off | 10. Raise the right section. | 14. Center section spray |
| 3. Agitation—on | 7. Lower the left section. | 11. Engine speed—fast | 15. Right section spray |
| 4. Agitation—off | 8. Raise the left section. | 12. Engine speed—slow | |

Setup

Loose Parts

Use the chart below to verify that all parts have been shipped.

Procedure	Description	Qty.	Use
1	No parts required	–	Check the boom-hinge springs.
2	Quick-disconnect fitting	1	Assemble the sprayer tank fill fitting.
3	No parts required	–	Remove the shipping bumper.

Media and Additional Parts

Description	Qty.	Use
Starter key	2	Read the manuals and watch the training materials before operating the machine.
Operator's Manual	1	
Engine owner's manual	1	
Parts Catalog	1	
Operator training materials	1	
Screen filter	2	

Note: Determine the left and right sides of the machine from the normal operating position.

Note: If you have questions or need additional information regarding the spray control system, refer to the *Operator's Manual* supplied with the system.

Important: This sprayer is sold without nozzles.

To use the sprayer, *you must obtain and install nozzles*. Contact your Authorized Toro Distributor for information on the available section kit and accessories.

After you install your nozzles and before using the sprayer for the first time, adjust the section bypass valves so that the pressure and application rate remains the same for all sections when you turn 1 or more sections off. Refer to [Setting the Section-Bypass Valves \(page 38\)](#).

1

Checking the Boom-Hinge Springs

No Parts Required

Procedure

Important: Operating the spray system with the boom-hinge springs under the incorrect compression could damage the boom assembly. Measure the springs and use the jam nut to compress the springs to 3.96 cm (1.56 inches), if necessary.

The sprayer may come with the boom extensions swung forward to facilitate shipping of the machine. The springs are not fully tightened at the time of manufacture to allow the position of the booms for transit. Before operating the machine, adjust the springs to the correct compression.

1. If necessary, remove the packing components that secure the right and left extension booms during shipping.
2. Support the booms while they are extended to the spray position.
3. At the boom hinge, measure the compression of the upper and lower springs while the booms are in the extended position ([Figure 3](#)).
 - A. Compress all springs until they measure 3.96 cm (1.56 inches).

- B. Use the jam nut to compress any spring that measures greater than 3.96 cm (1.56 inches).

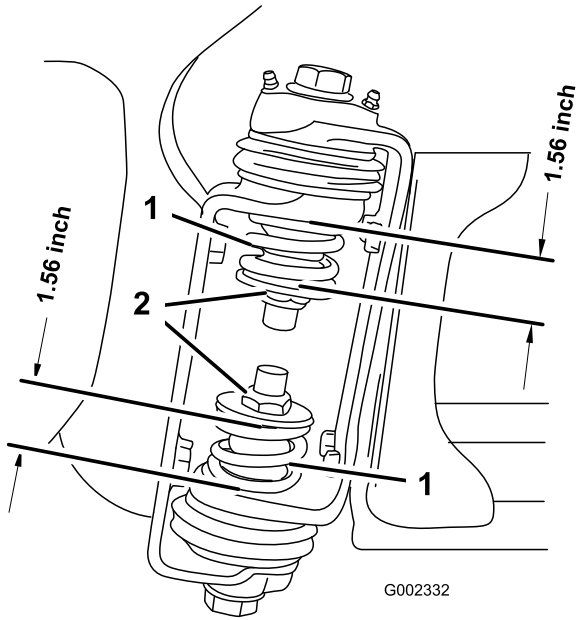

Figure 3

1. Boom-hinge spring 2. Jam nut

4. Repeat the procedure for each spring on both boom hinges.
5. Move the booms into the transport “X” position; refer to [Operating the Boom-Transport Cradle](#) (page 32).

2

Assembling the Sprayer Tank Fill Fitting

Parts needed for this procedure:

1	Quick-disconnect fitting
---	--------------------------

Procedure

Note: To complete this procedure, you will need to supply a hose with 1 inch male national pipe thread (NPT) fitting and PTFE thread sealant.

1. At the forward, right side of the tank cover, remove the 2 hairpins that secure the latches for the quick-disconnect coupling for the anti-siphon fill receptacle ([Figure 4](#)).

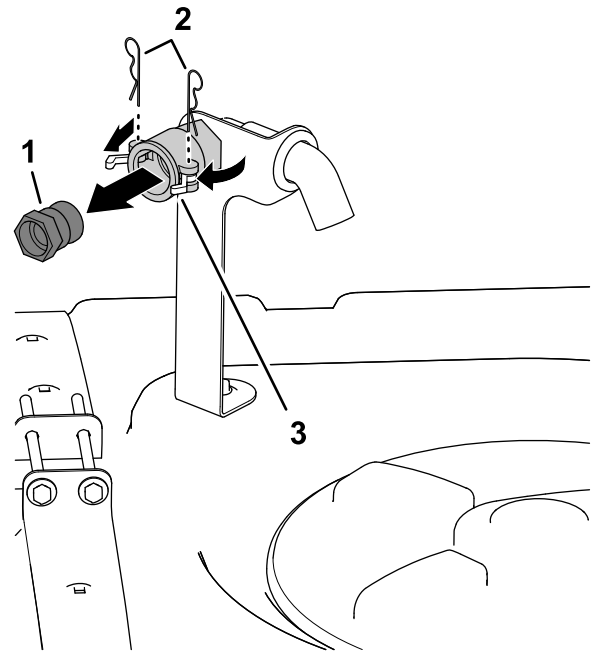

Figure 4

1. Quick-disconnect fitting 3. Latches (quick-disconnect coupling)
2. Hairpins

2. Rotate the latches open to unlock the quick-disconnect fitting from the quick-disconnect coupling ([Figure 4](#)).
3. Remove the quick-disconnect fitting from the quick-disconnect coupling ([Figure 4](#)).
4. Close the latches and install the hair pins into the flanges of the quick-disconnect coupling ([Figure 4](#)).
5. Apply PTFE thread sealant ([Figure 5](#)) to the threads of the fill hose fitting (1 inch—national pipe thread).

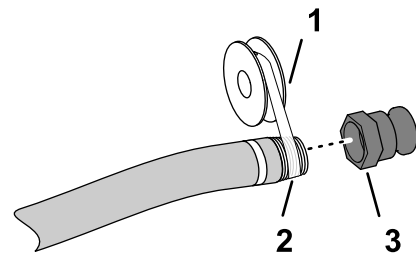

Figure 5

1. PTFE thread sealant 3. Quick-disconnect fitting
2. fill hose fitting (1 inch—national pipe thread)

6. Thread the quick-disconnect coupling onto the fill hose and tighten it by hand ([Figure 5](#)).

3

Removing the Shipping Bumper

No Parts Required

Procedure

1. Remove the bolts, washers, and nuts that secure the shipping bumper to the front chassis plate (Figure 6).

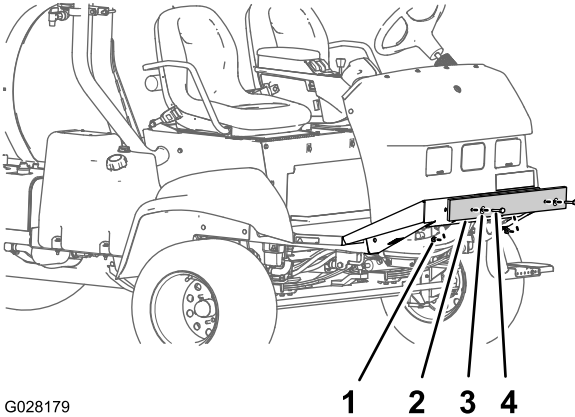

G028179

g028179

Figure 6

- | | |
|--------------------|-----------|
| 1. Nut | 3. Washer |
| 2. Shipping bumper | 4. Bolt |

2. Remove the shipping bumper from the machine (Figure 6).

Note: Discard the bolts, washers, nuts, and shipping bumper.

Product Overview

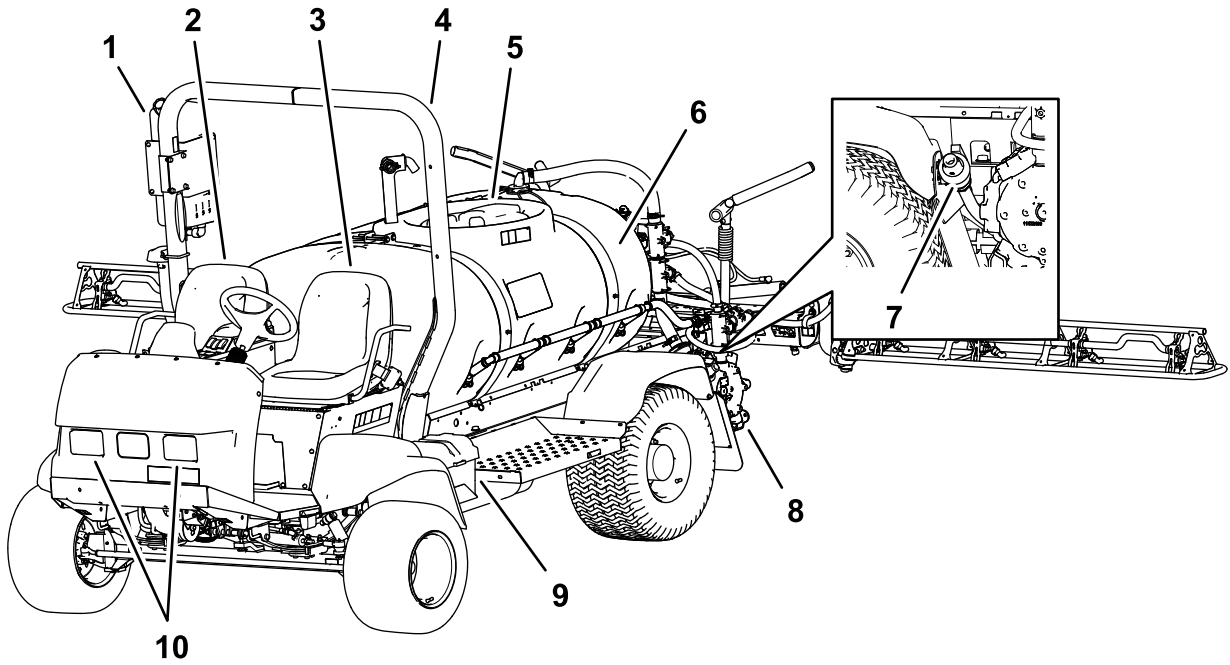

Figure 7

g190621

- | | | | |
|---------------------|--------------------|-------------------------------|-----------------|
| 1. Fresh-water tank | 4. Roll bar (ROPS) | 7. Drain valve (sprayer tank) | 10. Work lights |
| 2. Passenger seat | 5. Tank lid | 8. Spray pump | |
| 3. Operator's seat | 6. Chemical tank | 9. Battery | |

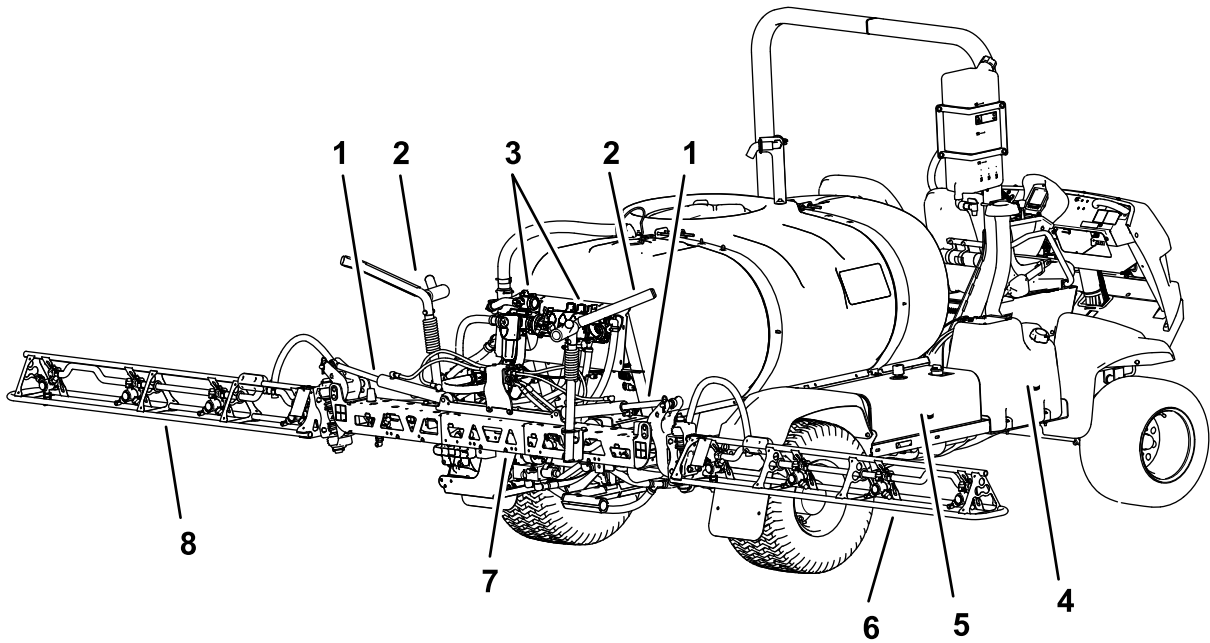

Figure 8

g190600

- | | | | |
|--------------------------|--------------------|-----------------------|------------------------|
| 1. Lift cylinder | 3. Valve manifolds | 5. Hydraulic tank | 7. Center boom section |
| 2. Boom-transport cradle | 4. Fuel tank | 6. Right boom section | 8. Left boom section |

Controls

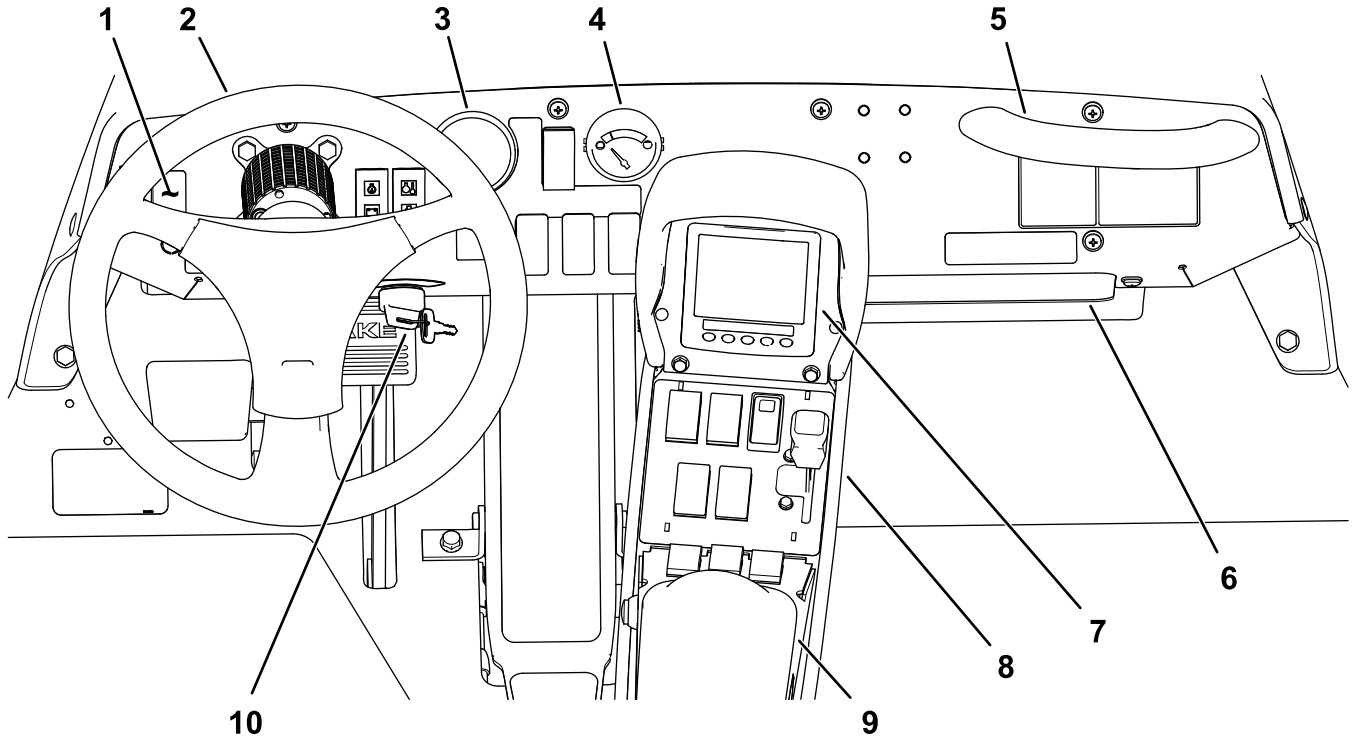

Figure 9

g216445

- | | |
|------------------------|------------------------|
| 1. Work-light switch | 6. Storage compartment |
| 2. Steering wheel | 7. InfoCenter |
| 3. Pressure gauge | 8. Quick Find™ console |
| 4. Fuel gauge | 9. Armrest |
| 5. Passenger-hand hold | 10. Ignition switch |

Vehicle Controls

Traction Pedal

The traction pedal (Figure 10) controls the movement of the machine, both forward and reverse. Using the toe to heel of the right foot, press the top of the pedal to move forward or the bottom of the pedal to move the machine in reverse. Release the pedal to slow and stop the machine.

Important: Ensure that you allow the sprayer to come to a stop before switching between the FORWARD and the REVERSE positions.

Note: The farther you press the pedal in either direction, the faster the sprayer travels. To obtain maximum forward speed, set the throttle lever to the FAST position and press the traction pedal all the way forward.

Note: To get maximum power under heavy load or when ascending a hill, move the throttle in the FAST position while pressing traction pedal slightly to keep the engine speed high. When the engine speed

begins to decrease, release the traction pedal slightly to allow the engine speed to increase.

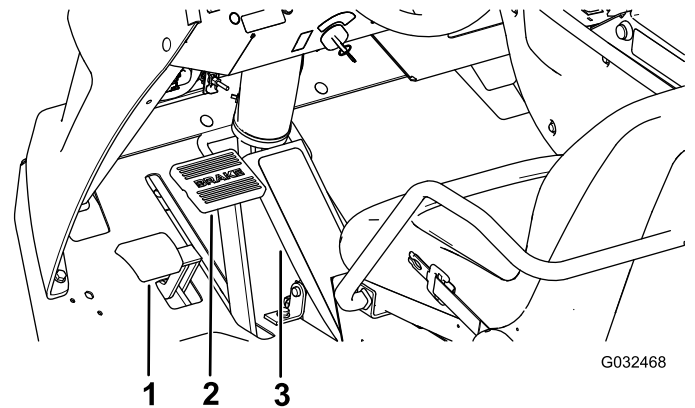

G032468

Figure 10

g032468

- | | |
|------------------------|-------------------|
| 1. Parking-brake pedal | 3. Traction pedal |
| 2. Brake pedal | |

Brake Pedal

Use the brake pedal to stop or slow the machine (Figure 10).

CAUTION

If you operate the sprayer with poorly adjusted or worn brakes, you could lose control of the sprayer, resulting in serious injury or death to you or bystanders.

Always check the brakes before operating the sprayer and keep them properly adjusted and repaired.

Parking Brake

The parking brake is a pedal to the left of the brake pedal (Figure 10). Engage the parking brake whenever you leave the seat to prevent the sprayer from accidentally moving. To engage the parking brake, press the brake pedal and while holding the brake, press the parking-brake pedal. To disengage, press and release the brake pedal. If the sprayer is parked on a steep grade, apply the parking brake and place chocks on the downhill side of the wheels.

Ignition Switch

The ignition switch (Figure 9), is used to start and shut off the engine, and the switch has 3 positions: OFF, ON/PREHEAT, and START.

Speed-Lock Switch

The speed-lock switch locks the position of the traction pedal when the switch is set (Figure 11). This ensures that the sprayer travels at a constant speed while driving the machine on level ground.

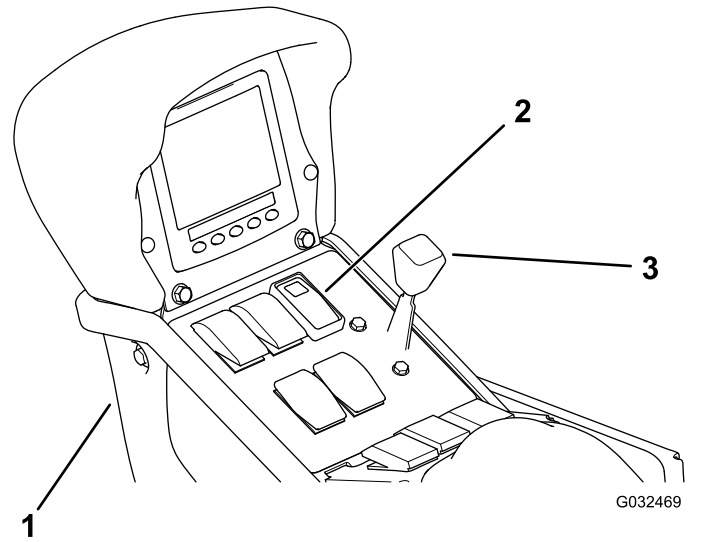

Figure 11

1. Center console
2. Speed-lock switch
3. Throttle lever

Throttle Lever

The throttle lever is located on the control panel between the seats (Figure 11), and the throttle is used to control the engine speed. Push the lever forward to increase the engine speed and pull it rearward to decrease the engine speed.

Work-Light Switch

Toggle the switch to operate the work lights (Figure 9). Push it forward to turn the lights on and rearward to turn them off.

Fuel Gauge

The fuel gauge is located on the dash of the machine and the gauge displays the level of the fuel in the tank (Figure 9).

USB Power Port

The 2-socket USB power port is located at the back of the armrest (Figure 12).

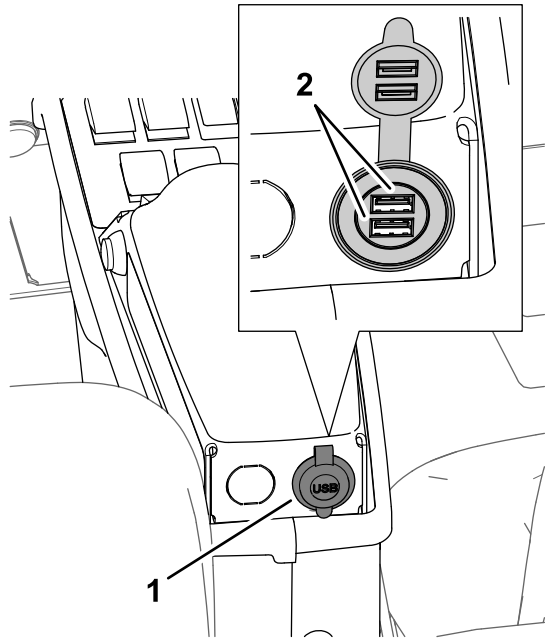

Figure 12

g194424

1. USB port

2. USB sockets

Engine Warning and Indication Lights

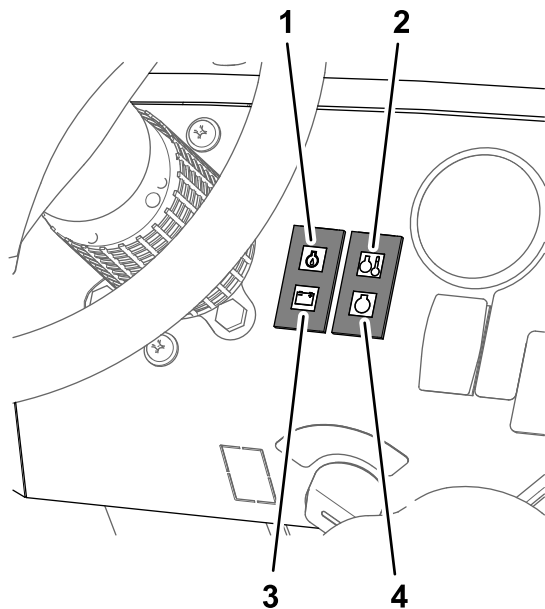

Figure 13

g190721

1. Oil-pressure-warning light

3. Battery-voltage-warning light

2. Coolant-temperature-warning light

4. Glow-plug-indicating light

Oil-Pressure-Warning Light

The engine oil-pressure warning light illuminates when the oil pressure drops below 48 kPa (7 psi).

When the machine is operating normally, the oil-pressure warning light illuminates when the ignition switch is rotated to the ON and shuts off when the engine is running.

Coolant-Temperature-Warning Light

The coolant-temperature-warning light illuminates when the coolant temperature is hotter than 102 to 108° C (216 to 226° F).

Battery-Voltage-Warning Light

The battery-voltage-warning light illuminates when the alternator voltage drops 1.5 V below the battery voltage or greater.

When the machine is operating normally, the battery-voltage-warning light illuminates when the ignition switch is rotated to the ON and shuts off when the engine is running.

Glow-Plug-Indicating Light

The glow plug indicating light illuminates while the glow plug is energized. When the ignition key is rotated to the ON position, the glow plug indicating light illuminates for 6 seconds while the glow plug is energized. When the glow plug indicating light shuts off, the engine is ready to start.

Sprayer Controls

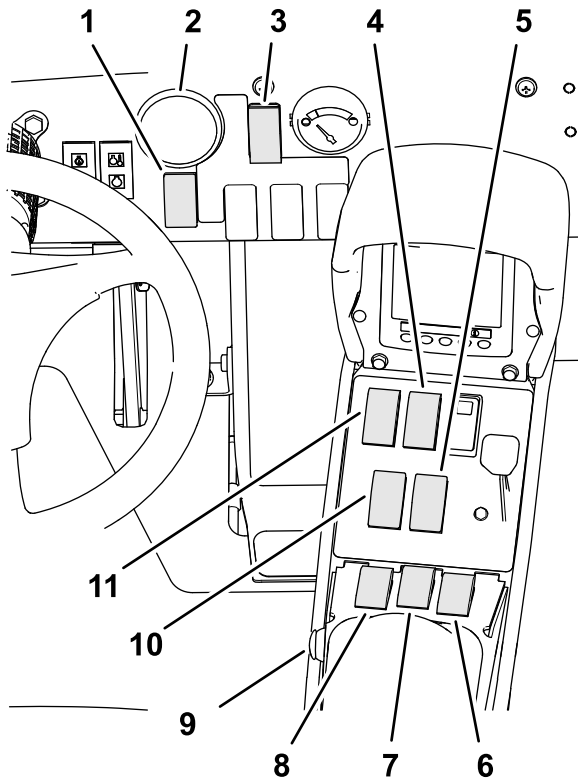

Figure 14

g194086

- | | |
|-----------------------------------|-----------------------------------|
| 1. Application-rate switch | 7. Center-section switch |
| 2. Pressure gauge | 8. Left-section switch |
| 3. Spray-mode switch | 9. Master section switch |
| 4. Tank-agitation switch | 10. Left boom-section lift switch |
| 5. Right boom-section lift switch | 11. Spray-pump switch |
| 6. Right-section switch | |

Pressure Gauge

The pressure gauge (Figure 14) is located on the dash. This gauge shows the pressure of the fluid in the spray system in psi and kPa.

Spray-Mode Switch

Use the spray-mode switch to change between the application rate mode (closed loop) and the manual mode (open loop).

Application-Rate Switch

The application-rate switch is located on the dash to the right of the steering wheel (Figure 14). Use the application-rate switch to control the spray pump speed when operating the sprayer in the manual mode. Press and hold the switch forward to increase the application rate (pressure), or press and hold it rearward to decrease the application rate (pressure).

Spray-Pump Switch

The spray-pump switch is located on the center console to the right of the seat (Figure 14). Toggle this switch forward to run the spray pump or rearward to stop the pump. When the switch is turned on, a light on the switch illuminates.

Important: Engage the spray-pump switch only when the engine is at LOW IDLE to avoid damaging the pump drive.

Boom-Section Lift Switches

The boom-section lift switches are located on the center console to the right of the seat and used to raise or lower the left and right boom sections (Figure 14).

Master Section Switch

The master section switch is located on the center console of the machine. The switch allows you to start or stop the spray operation. Press the switch to enable or disable the spray system (Figure 14).

Left, Center, and Right Section Switches

The 3 section switches are located on the center console in the front of the armrest (Figure 14). Toggle each switch forward to turn the corresponding section on and rearward to turn each off. When the switch is in the ON position, an icon appears at the top of the InfoCenter.

Note: These switches affect the spray system only when the master section switch is in the ON position.

Agitation Switch

The agitation switch is located on the center console to the right of the seat (Figure 14). Toggle this switch forward to turn on the agitation in the tank or rearward to stop the agitation. When the switch is turned on, a light on the switch illuminates. To operate the agitation function, you must run the sprayer system pump and you must run the engine above low idle.

Agitation-Bypass Valve

The agitation-bypass valve redirects the flow of fluid to the sprayer-system pump when you turn off the agitation function (Figure 15). The agitation-bypass valve is located above the agitation valve. You can adjust the bypass valve to ensure that the pressure remains constant when cycling agitation on or off; refer to [Calibrating the Agitation-Bypass Valve \(page 39\)](#).

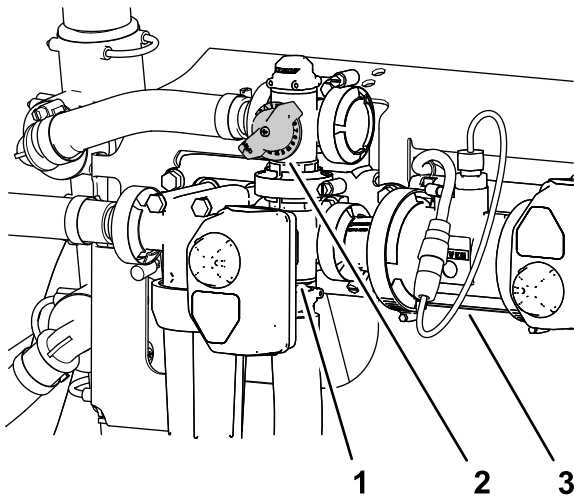

Figure 15

g194246

- 1. Actuator (agitation valve)
- 2. Agitation-bypass-valve handle
- 3. Flow meter

Flowmeter

The flowmeter measures the flow rate of the fluid for use by the InfoCenter system and when spraying in the application rate mode (Figure 15).

Agitation-Throttle Valve

The agitation-throttle valve is a manually-operated ball valve that controls flow to the agitation nozzles in the main tank. This valve allows the sprayer-operator to control the sprayer-system pressure at the agitation nozzles of the main tank when larger application rates are required. The agitation-throttle valve is located above the pump (Figure 16).

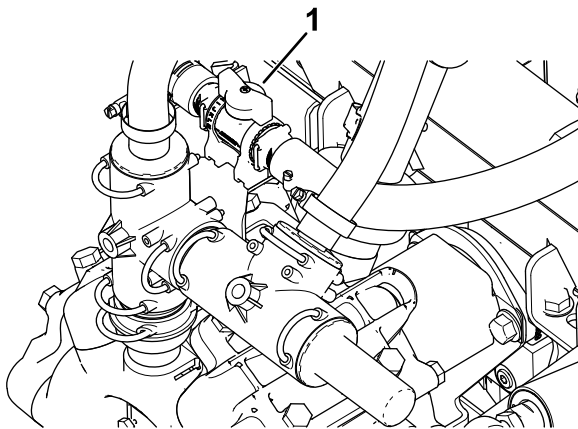

Figure 16

G032528

g032528

- 1. Agitation-throttle-valve handle

Section Bypass Valves

The section bypass valves are used to adjust the sprayer system pressure to the section valves in order to ensure that the sprayer pressure to the spray section remains constant no matter how many spray sections are on. (Figure 17).

Note: Use the bypass valves when spraying in the manual mode (open loop) only.

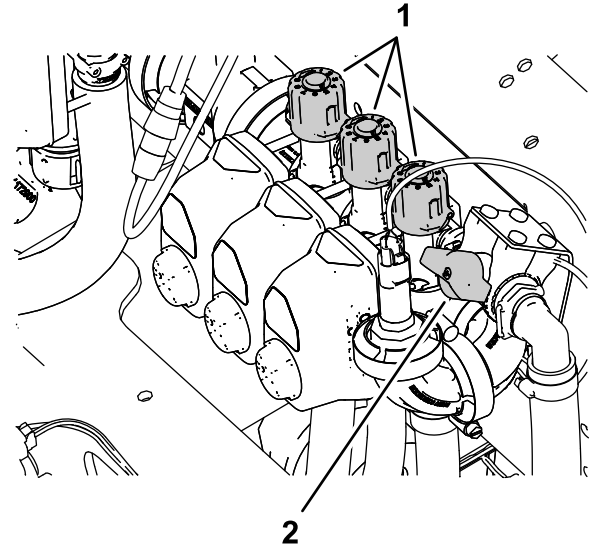

Figure 17

g190774

- 1. Knob (section-bypass valves)
- 2. Section-bypass shutoff valve

Section-Bypass Shutoff Valve

Use the section-bypass shutoff valve to control fluid flow from the section bypass valves to the tank when spraying in the manual mode (open loop); refer to Figure 17.

Note: Close the section-bypass shut off valve when spraying in the application rate mode (closed loop).

Anti-Siphon Fill Receptacle

At the front of the tank cover is a hose receptacle with a threaded fitting, a 90-degree barbed fitting, and a short hose, which you can direct toward the tank opening. This receptacle allows you to connect a water hose to it and fill the tank with water without contaminating the hose with the chemicals in the tank.

Important: Do not lengthen the hose to allow contact with the tank fluids. The distance from the end of the hose to the uppermost water level should be within local regulatory limits.

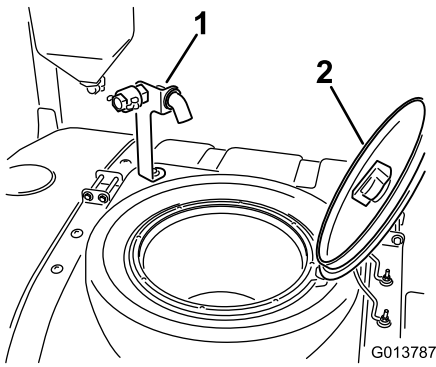

Figure 18

1. Anti-siphon fill receptacle 2. Tank cover

Tank Cover

The tank cover is located in the center, top of the tank. To open the cover, shut off the engine, turn the front half of the cover to the left, and swing it open. You can remove the strainer inside for cleaning. To seal the tank, close the cover and rotate the front half toward the right.

InfoCenter Controls

The InfoCenter controls use the 5 buttons below the LED display to navigate menus, enter data, and change functions.

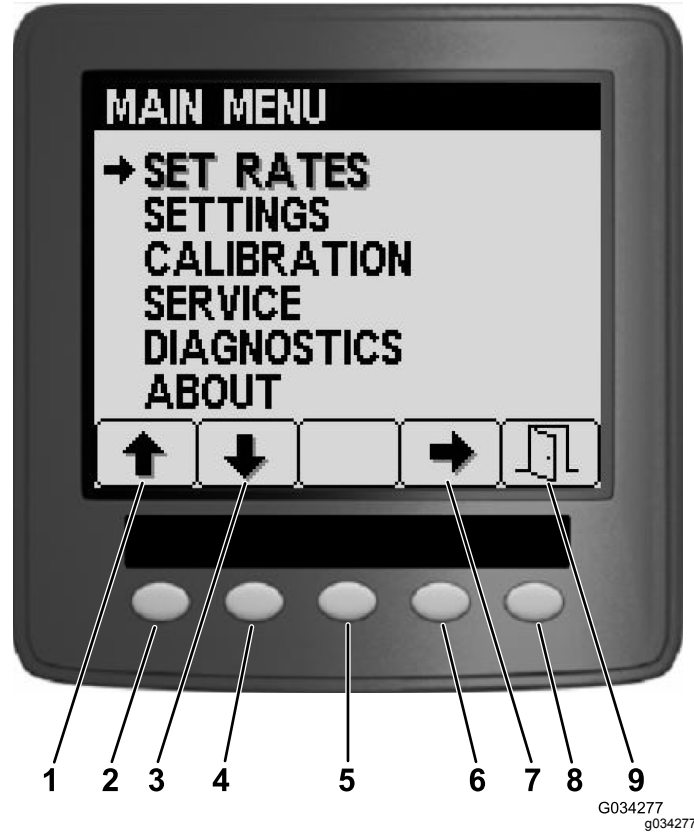

Figure 19

- | | |
|---------------|-----------------|
| 1. Up arrow | 6. Button 4 |
| 2. Button 1 | 7. Select arrow |
| 3. Down arrow | 8. Button 5 |
| 4. Button 2 | 9. Exit |
| 5. Button 3 | |

Specifications

Note: Specifications and design are subject to change without notice.

Machine Specifications

Description	Measurement
Base weight	1307 kg (2,882 lb)
Weight with standard spray system, empty, without operator	1307 kg (2,882 lb)
Weight with standard spray system, full, without operator	2499 kg (5,510 lb)
Maximum gross vehicle weight (GVW) (on level ground)	3023 kg (6,665 lb)
Tank capacity	1135.6 L (300 US gallons)
Overall width with standard spray system sections stored in the X position	226 cm (89 inches)

Sprayer Specifications

Description	Measurement
Overall length with standard spray system	391 cm (154 inches)
Overall length with standard spray system to the top of the sections stored in the X position	442 cm (174 inches)
Overall height with standard spray system	146 cm (57.5 inches)
Overall height with standard spray system to the top of the sections stored in the X position	231 cm (91 inches)
Ground clearance	18.4 cm (7.25 inches)
Wheel base	198 cm (78 inches)

Optional Equipment—The Toro Company has optional equipment and accessories that you can purchase separately and install on your sprayer. Contact your Authorized Service Dealer for a complete list of optional equipment that is currently available for your sprayer.

Operation

Note: Determine the left and right sides of the machine from the normal operating position.

Think Safety First

Please carefully read all of the safety instructions and decals in the safety section. Knowing this information could help you or bystanders avoid injury.

Performing Pre-Starting Checks

Check the following items each time you begin use of the sprayer for the day:

- Check the air pressure in the tires.

Note: The tires of this machine are different than car tires; they require less air pressure in order to minimize turf compaction and damage.

- Check all fluid levels and add the appropriate amount of specified fluids, if any are found to be low.
- Check the brake pedal operation.
- Check to see that the lights are working.
- With the engine shut off, check for oil leaks, loose parts, and any other noticeable malfunctions.

If any of the above items are not correct, notify your mechanic or check with your supervisor before taking the sprayer out for the day. Your supervisor may want you to check other items on a daily basis, so ask what your responsibilities are.

Preparing to Drive the Machine

Checking the Engine-Oil Level

Before you start the engine and use the machine, check the oil level in the engine crankcase; refer to [Checking the Engine Oil \(page 55\)](#).

Checking the Cooling System

Before you start the engine and use the machine, check the cooling system; refer to [Checking the Coolant Level \(page 65\)](#).

Checking the Hydraulic System

Before you start the engine and use the machine, check the hydraulic system; refer to [Checking the Hydraulic Fluid \(page 68\)](#).

Checking the Tire Air Pressure

Service Interval: Before each use or daily

Check the tire air pressure in the tires to ensure proper levels. Fill the tires to 138 kPa (20 psi).

Note: Also, check the tires for wear or damage.

Checking the Brakes

Service Interval: Before each use or daily

Before starting the sprayer, lightly press the brake pedal. If the pedal travels more than 2.5 cm (1 inch) before you feel resistance, adjust the brakes; refer to [Adjusting the Brakes \(page 67\)](#).

⚠ WARNING

If you operate the sprayer with poorly adjusted or worn brakes, you could lose control of the sprayer, resulting in serious injury or death to you or bystanders.

Always check the brakes before operating the sprayer and keep them properly adjusted and repaired.

Adding Fuel

⚠ DANGER

In certain conditions, fuel is extremely flammable and highly explosive. A fire or explosion from fuel can burn you and others and can damage property.

- Fill the fuel tank outdoors, in an open area, when the engine is cold. Wipe up any fuel that spills.
- Do not fill the fuel tank completely full. Add fuel to the fuel tank until the level is 25 mm (1 inch) below the bottom of the filler neck. This empty space in the tank allows fuel to expand.
- Never smoke when handling fuel, and stay away from an open flame or where fuel fumes may be ignited by a spark.
- Store fuel in an approved container and keep it out of the reach of children. Never buy more than a 30-day supply of fuel.

⚠ DANGER

In certain conditions during fueling, static electricity can be released, causing a spark the can ignite the fuel vapors. A fire or explosion from fuel can burn you and others and can damage property.

- Always place fuel containers on the ground away from your vehicle before filling.
- Do not fill fuel containers inside a vehicle or on a truck or trailer bed because interior carpets or plastic truck bed liners may insulate the container and slow the loss of any static charge.
- When practical, remove diesel-powered equipment from the truck or trailer and refuel the equipment with its wheels on the ground.
- If this is not possible, then refuel such equipment on a truck or trailer from a portable container rather than from a fuel dispenser nozzle.
- If you must use a fuel dispenser nozzle, keep the nozzle in contact with the rim of the fuel tank or container opening at all times until fueling is complete.

Important: Your engine runs on No. 2-D or 1-D automotive-type diesel fuel with a minimum cetane rating of 40.

Note: Your engine may require a higher cetane-rated fuel if you operate the machine at high altitudes or in low atmospheric temperatures.

Using Biodiesel Fuel

This machine can also use a biodiesel blended fuel of up to B20 (20% biodiesel, 80% petrodiesel). The petrodiesel portion should be low or ultra low sulfur. Observe the following precautions:

- The biodiesel portion of the fuel must meet specification ASTM D6751 or EN14214.
- The blended fuel composition should meet ASTM D975 or EN590.
- Painted surfaces may be damaged by biodiesel blends.
- Use B5 (biodiesel content of 5%) or lesser blends in cold weather.
- Monitor seals, hoses, gaskets in contact with fuel as they may be degraded over time.
- Fuel filter plugging may be expected for a time after converting to biodiesel blends.
- Contact your distributor if you wish for more information on biodiesel.

Filling the Fuel Tank

Fuel tank capacity: approximately 45 L (12 US gallons).

1. Park the machine on a level surface, engage the parking brake, shut off the spray pump, shut off the engine, remove the key, and allow the engine to cool.
2. Clean the area around the fuel-tank cap (Figure 20).

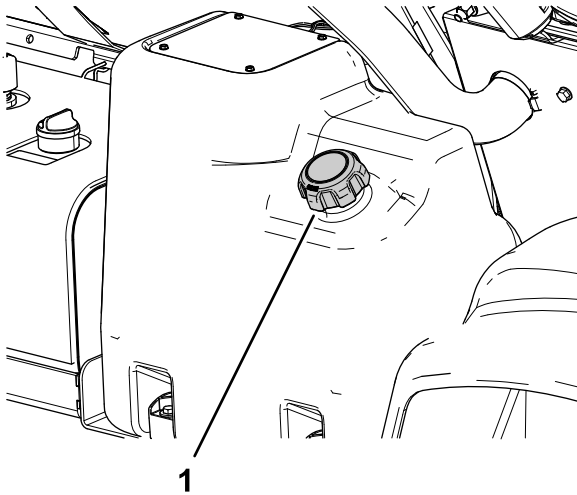

Figure 20

g194161

1. Fuel-tank cap

3. Remove the fuel-tank cap.
4. Fill the tank to about 2.5 cm (1 inch) below the top of the tank (bottom of the filler neck).

Note: This air space in the tank allows fuel to expand. **Do not overfill the tank.**

5. Install the fuel-tank cap to the tank securely.
6. Wipe up any fuel that may have spilled.

Preparing to Use the Sprayer

Cleaning the Suction Filter

Service Interval: Before each use or daily—Clean the suction filter. Clean the suction filter (more often when using wettable powders).

1. Park the machine on a level surface, engage the parking brake, shut off the pump, shut off the engine, and remove the key.
2. At the top of the sprayer tank, remove the retainer that secures the hose fitting attached to the large hose from the filter housing (Figure 21).

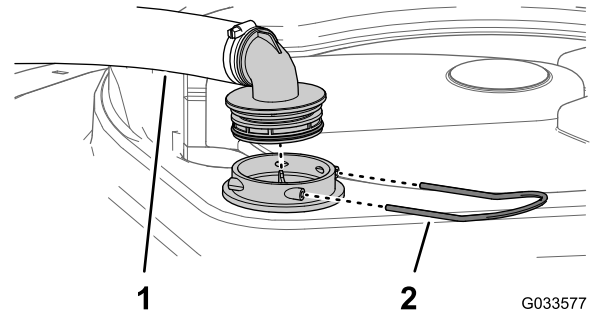

Figure 21

G033577

g033577

1. Suction hose
2. Retainer

3. Remove the hose and hose fitting from the filter housing (Figure 21).
4. Pull the suction strainer out of the filter housing in the tank (Figure 22).

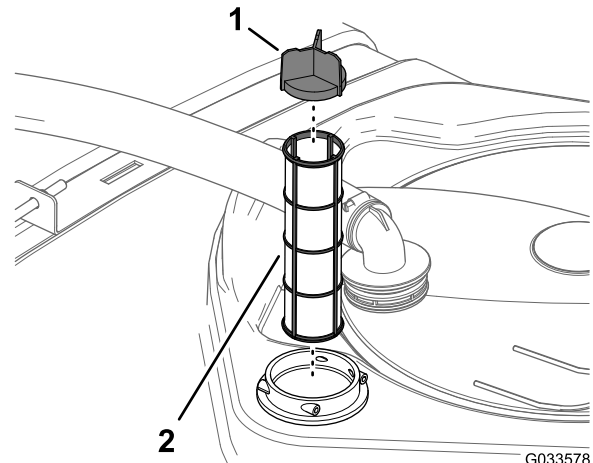

Figure 22

G033578

g033578

1. Screen vane
2. Suction strainer

5. Clean the suction filter with clean water.

Important: Replace the filter if it is damaged or cannot be cleaned.

6. Insert the suction filter into the filter housing until the filter is fully seated.
7. Align the hose and hose fitting to the filter housing at the top of the tank, and secure fitting and housing with the retainer that you removed in step 2.

Cleaning the Pressure Filter

Service Interval: Before each use or daily—Clean the pressure filter. Clean the pressure filter (more often when using wettable powders).

1. Park the machine on a level surface, engage the parking brake, shut off the sprayer pump, shut off the engine, and remove the key.
2. Align a drain pan under the pressure filter (Figure 23).

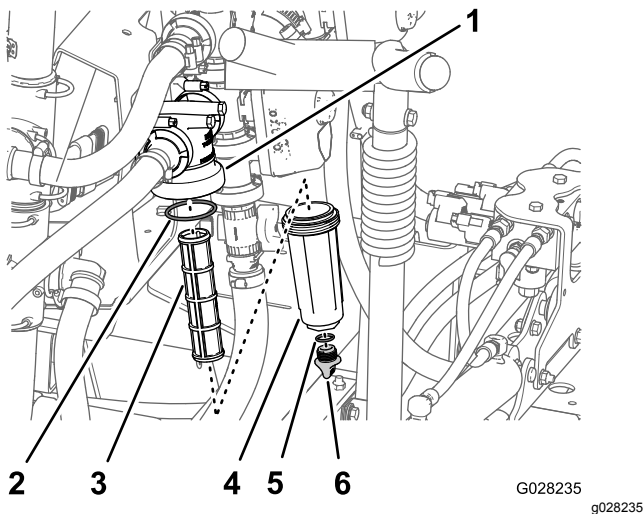

Figure 23

- | | |
|-------------------|-----------------------|
| 1. Filter head | 4. Bowl |
| 2. Gasket (bowl) | 5. Gasket (drain cap) |
| 3. Filter element | 6. Drain cap |

3. Rotate the drain cap counterclockwise and remove it from the bowl of the pressure filter (Figure 23).

Note: Allow the bowl to drain completely.

4. Rotate the bowl counterclockwise and remove the filter head (Figure 23).
5. Remove the pressure filter element (Figure 23).
6. Clean the pressure filter element with clean water.

Important: Replace the filter if it is damaged or cannot be cleaned.

7. Check the gasket for the drain plug (located inside the bowl) and the gasket for bowl (located inside the filter head) for damage and wear (Figure 23).

Important: Replace any damaged or worn gaskets for the plug, bowl, or both.

8. Install the pressure filter element into the filter head (Figure 23).
- Note:** Ensure that the filter element is firmly seated into the filter head.
9. Install the bowl onto the filter head, and tighten by hand (Figure 23).
10. Assemble the drain cap onto the fitting at the bottom of the bowl, and tighten the cap by hand (Figure 23).

Cleaning the Nozzle Filter

1. Park the machine on a level surface, engage the parking brake, shut off the sprayer pump, shut off the engine, and remove the key.
2. Remove the nozzle from the spray turret (Figure 24).

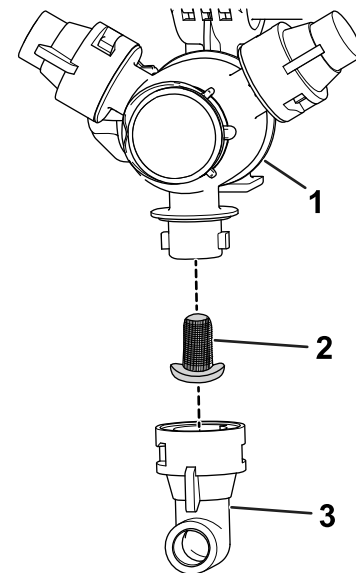

Figure 24

- | | |
|------------------|-----------|
| 1. Spray turret | 3. Nozzle |
| 2. Nozzle filter | |

3. Remove the nozzle filter (Figure 24).
4. Clean the nozzle filter with clean water.

Important: Replace the filter if it is damaged or cannot be cleaned.

5. Install the nozzle filter (Figure 24).

Note: Ensure that the filter is fully seated.

6. Install the nozzle onto the spray turret (Figure 24).

Inspecting the Tank Straps

Service Interval: Before each use or daily—Check the tank straps.

Important: Overtightening the tank strap fasteners can result in deforming and damaging the tank and straps.

1. Fill the main tank with water.
2. Check to see if there is any movement between the tank straps and the tank (Figure 25).

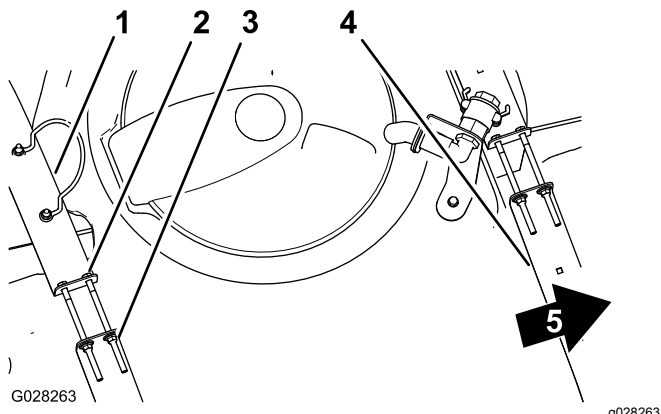

Figure 25

- | | |
|--------------------|-------------------------|
| 1. Rear tank strap | 4. Forward tank strap |
| 2. Bolt | 5. Front of the machine |
| 3. Flanged locknut | |

3. If the tank straps fit loose to the tank, tighten the flanged locknuts and bolts at the top of straps until the straps are flush with the surface of the tank (Figure 25).

Note: Do not overtighten the tank strap hardware.

Operating the Machine

Starting the Engine

1. Sit on the operator's seat and keep your foot off the traction pedal.
2. Ensure that the following controls are set:
 - The parking brake is engaged.
 - The traction pedal is in the NEUTRAL position.
 - The spray pump is shut off.
 - The throttle is in the SLOW position.
3. Turn the switch to the ON/PREHEAT position.

Note: An automatic timer controls the preheat for approximately 6 seconds.

4. After preheating, turn the key to the START position.
5. Crank the engine for no longer than 15 seconds.

6. Release the key when the engine starts.
7. If the engine requires additional preheating, turn the key to the OFF position, then to the ON/PREHEAT position.

Note: Repeat steps 3 through 7 as required.

8. Run the engine at IDLE speed or partial throttle until the engine warms up.

Driving the Machine

1. Release the parking brake and press the traction pedal forward to drive the machine forward or press the pedal rearward to drive the machine in reverse.

Important: Ensure that you allow the sprayer to come to a stop before switching between the FORWARD and REVERSE positions.

2. To slowly stop the machine, release the traction pedal.

Note: The traction pedal returns to the NEUTRAL position.

3. To stop quickly, press the brake pedal.

Note: The stopping distance of the machine may vary depending on the sprayer-tank load and ground speed of the machine.

Setting the Ground-Speed-Lock Switch

⚠ CAUTION

If you press the ground-speed-lock switch and do not have your foot on the traction pedal, the traction unit may suddenly stop and cause you to lose control, possibly injuring you or bystanders.

Ensure that you have your foot on the traction pedal when you disengage the ground-speed-lock switch.

1. Start the spray pump by pressing the spray-pump switch to the ON position; refer to [Spray-Pump Switch \(page 22\)](#).
2. Drive forward and attain the desired ground speed; refer to [Driving the Machine \(page 29\)](#).

Note: You must drive the machine less than 11 km/h 7 mph to set the ground-speed lock.

3. Press the top of the ground-speed-lock switch.

Note: The light on the switch illuminates.

4. Take your foot off the traction pedal.

Note: The sprayer maintains the speed that you set.

5. To release the ground-speed-lock switch, either place your foot on the traction pedal and press the bottom of the switch or remove your foot from the traction pedal and press the brake pedal.

Note: The light on the switch turns off and the traction control returns to the traction pedal.

Shutting Off the Engine

1. Move all the controls to the NEUTRAL position.
2. Press the brake to stop the sprayer.
3. Engage the parking brake.
4. Move the throttle lever to the IDLE/SLOW position.
5. Turn the starter key to the OFF position.
6. Remove the key from the switch to prevent someone from accidentally starting the engine.

Breaking in a New Sprayer

Service Interval: After the first 100 hours

- Check the engine-oil and fluid levels regularly and be alert for indications of overheating in any component of the sprayer.
- After filling the tank, check the tank straps for any play. Tighten as necessary; refer to [Inspecting the Tank Straps \(page 29\)](#).
- After starting a cold engine, let it warm up for about 15 seconds before accelerating.
- Avoid hard-braking situations for the first several hours of new sprayer break-in operation. New brake linings may not give optimum performance until several hours of use has caused the brakes to become burnished (broken-in).
- Avoid racing the engine.
- Refer to [Maintenance \(page 45\)](#) for any special, low-hour checks.

Operating the Sprayer

To operate the Multi Pro® Sprayer, first fill the sprayer tank, apply the chemicals to the job site, and finally clean the tank and spray system. It is important that you complete all 3 of these steps in succession to avoid damaging the sprayer. For example, do not mix and add chemicals in the sprayer tank at night and then spray in the morning. This leads to separation of the chemicals and possible damage to the sprayer components.

⚠ CAUTION

Chemicals are hazardous and can cause personal injury.

- **Read the directions on the chemical labels before handling the chemicals and follow all manufacturer recommendations and precautions.**
- **Keep chemicals away from your skin. Should contact occur, wash the affected area thoroughly with soap and clean water.**
- **Wear goggles and any other protective equipment recommended by the chemical manufacturer.**

The Multi Pro® Sprayer has been specifically designed to have high durability in order to provide the long sprayer life you need. Different materials have been chosen for specific reasons at different locations on your sprayer to meet this goal. Unfortunately, there is no single material which is perfect for all foreseeable applications.

Some chemicals are more aggressive than others and each chemical interacts differently with various materials. Some consistencies (e.g., wettable powders, charcoal) are more abrasive and lead to higher wear rates. If a chemical is available in a formulation that would provide increased life to the sprayer, use this alternative formulation.

As always, remember to clean your sprayer and spray system thoroughly after all applications. This ensures that your sprayer has a long and trouble-free life.

Note: If you have questions or need additional information regarding the spray-control system, refer to the *Operator's Manual* supplied with the system.

Filling the Fresh-Water Tank

Always fill the fresh-water tank with clean water before handling or mixing any chemicals.

The fresh-water tank is located on the ROPS, behind the passenger seat ([Figure 26](#)).

Note: It supplies a source of fresh water for you to wash chemicals off your skin, eyes, or other surfaces in the case of accidental exposure.

- To fill the tank, unscrew the cap on the top of the tank, fill the tank with fresh water, and tighten the cap.
- To open the fresh-water tank spigot, turn the lever on the spigot.

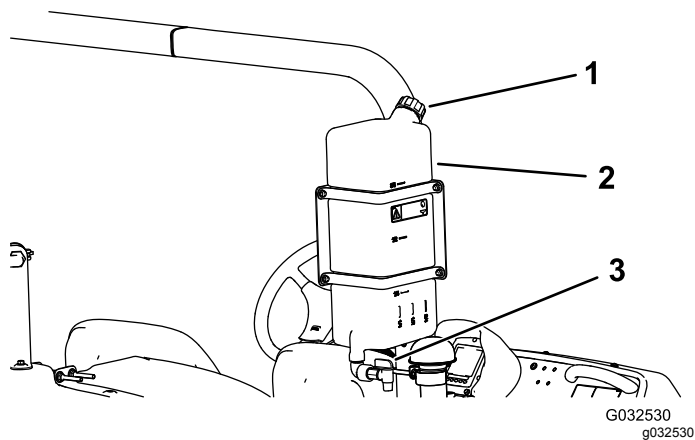

Figure 26

1. Filler cap
2. Fresh-water tank
3. Spigot

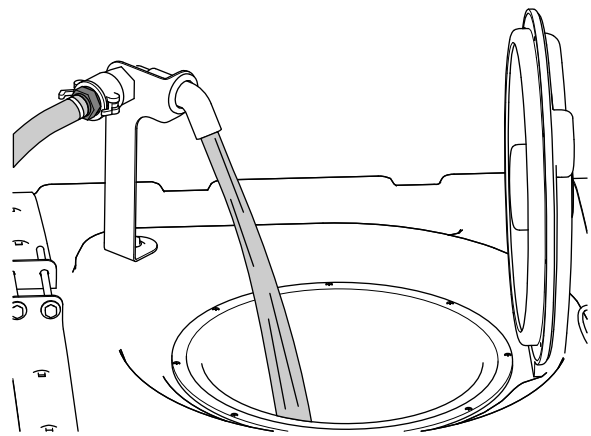

Figure 27

6. Start the engine, engage the parking brake, set the spray-pump switch to the ON position, and move the throttle lever to HIGH IDLE.
7. Set the agitation switch to the ON position.

Important: Prior to introducing wettable powders into any Toro Spray System mix the powders in a suitable container with sufficient fresh water to create a free flowing slurry. Failure to do so may result in chemical deposits on the bottom of the tank, degraded agitation, clogging of filters, and improper application rates.

Toro recommends using the approved Educator Kit for this machine. Contact your Authorized Toro Dealer for more information.

8. Add the proper amount of chemical concentrate to the tank, as directed by the chemical manufacturer.
9. Add the remaining water to the tank, remove the fill hose, and close the tank cover.

Note: To seal the tank, close the cover and rotate the front half clockwise.

Filling the Spray Tank

Important: Ensure that the chemicals you use are compatible with Viton™ (see the manufacturer's label; it should indicate if it is not compatible). Using a chemical that is not compatible with Viton will degrade the O-rings in the sprayer, causing leaks.

Important: The tank-volume markings are for reference only and cannot be considered accurate for calibration.

Important: After filling the tank for the first time, check the tank straps for any play. Tighten as necessary.

1. Stop the machine on a level surface, shut off the engine, and engage the parking brake.
2. Determine the amount of water needed to mix the amount of chemical you need as prescribed by the chemical manufacturer.
3. Open the tank cover on the spray tank.

Note: The tank cover is located in the center of the top of the tank. To open it, turn the front half of the cover counterclockwise and swing it open. You can remove the strainer under the tank cover and clean the strainer.

4. Assemble the fill hose to the quick disconnect fitting of the anti-siphon fill receptacle.
5. Add 3/4 of the required water to the spray tank (Figure 27).

Important: Always use fresh, clean water in the spray tank. Do not pour concentrate into an empty tank.

Operating the Spray Sections

The boom-section lift switches on the sprayer control panel allows you to move the outer spray sections between transport position and spray position without leaving the operator's seat. Whenever possible, stop the machine before changing spray section positions.

1. Stop the sprayer on level ground.
2. Use the boom-section lift switches to lower the outer spray sections.
Note: Wait until the sections reach the fully-extended spray position.
3. When you need to raise the spray sections, stop the sprayer on level ground.
4. Use the boom-section lift switches to raise the sections.

Note: Raise the sections until they have moved completely into section transport cradle, forming the "X" transport position and the section cylinders are fully retracted.

Important: To prevent damage to the section-actuator cylinder, ensure that the actuators are fully retracted before transport.

Important: Release the actuator switch once the outer spray sections have reached the desired position. Running the actuators against the mechanical stops may damage the lift cylinders and/or other hydraulic components.

Operating the Boom-Transport Cradle

The sprayer is equipped with a boom-transport cradle that has a unique safety feature. In the event of accidental boom contact with a low overhead object while in the transport position, the boom(s) can be pushed out of the transport cradles. If this occurs, the booms will come to rest in a near-horizontal position to the rear of the vehicle. While this movement will not damage the outer spray sections, they should be immediately put back into the transport cradle.

Important: The outer spray sections can be damaged by transporting them in any position other than the "X" transport position using the boom transport cradle.

To put the boom sections back into the transport cradle, lower the boom section(s) to the spray position, and then raise the boom section(s) back into the transport position. Ensure that the lift cylinders are fully retracted to prevent actuator rod damage during storage.

Sprayer Functions for Application Rate Mode and Manual Mode

Refer to the *Software Guide* for the Multi Pro 5800-D and 5800-G turf sprayers with ExcelaRate spray system for information on the following:

Before Operation

- The InfoCenter home screen
- The main menu screen
- The main menu sub-screens
- The service screens
- The diagnostic screens
- The About screens

During Operation

- Entering job information
- InfoCenter spray-area screens
- InfoCenter advisories

Spraying with the ExcelaRate Sprayer System

Refer to the *Software Guide* for the Multi Pro 5800-D and 5800-G turf sprayers with ExcelaRate spray system for information on the following procedures:

Important: To ensure that the product remains well mixed, use the agitation feature whenever you have solution in the tank.

Spraying in the Application Rate Mode

1. Ensure that the spray system is calibrated for the active spray nozzles that you have selected; Refer to the *Software Guide* for the Multi Pro 5800-D and 5800-G turf sprayers with ExcelaRate spray system.
2. Rotate the knob for the section-bypass shutoff valve to the closed position ([Figure 28](#)).

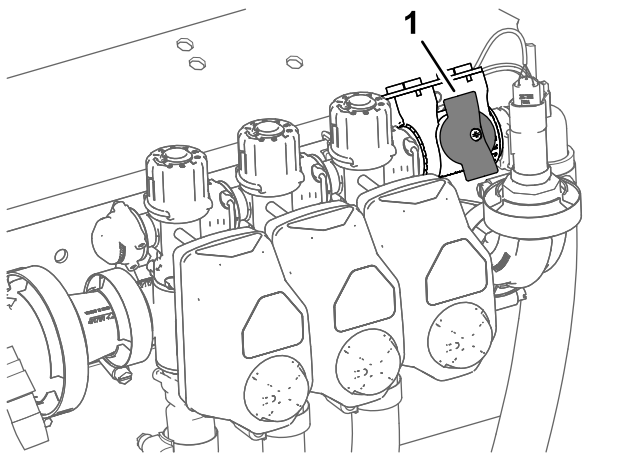

Figure 28

g192607

1. Section-bypass shutoff valve (closed position)

3. Set the sprayer mode button to the Application Rate Mode (Figure 29).

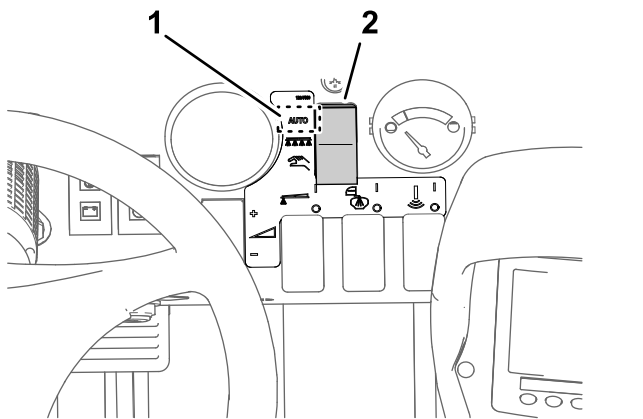

Figure 29

g193437

1. Application-rate mode position
2. Sprayer-mode switch

4. Move the sprayer to the area of turf that you are spraying.
5. If you are collecting area sprayed and volume sprayed data for each job site, select a sub-area screen (sub-areas 1 through 20) to record for the individual area and volume information; refer to Using the Sub-Area Screen in the *Software Guide* for the Multi Pro 5800-D and 5800-G turf sprayer with ExcelsaRate spray system.

Note: When you move to a different job site, you need to select another sub-area screen to record the individual area and volume information.

6. If you need to switch the active rate between the rate 1 value and the rate 2 value, from the InfoCenter home screen press buttons 1 and 2 simultaneously to select RATE 1 or press buttons 4 and 5 simultaneously to select RATE 2; Refer

to the *Software Guide* for the Multi Pro 5800-D and 5800-G turf sprayers with ExcelsaRate spray system.

7. Set the spray section switch(es) to the ON position (Figure 30).

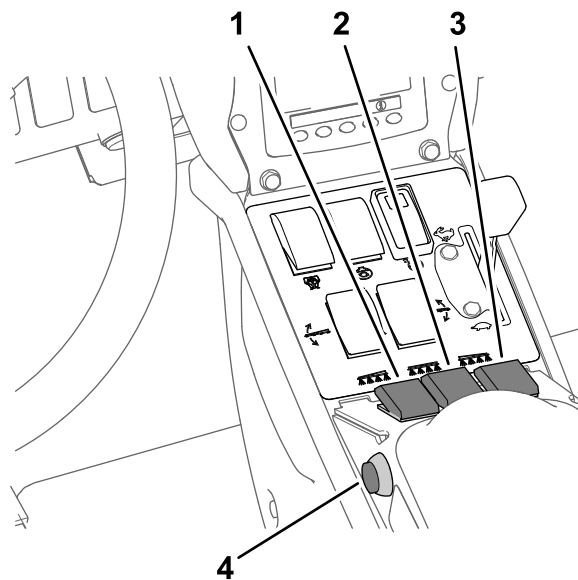

Figure 30

g192944

1. Left spray-section switch
2. Center spray-section switch
3. Right spray-section switch
4. Master section switch

8. Set the agitation switch and the spray-pump switch to the ON position (Figure 31).

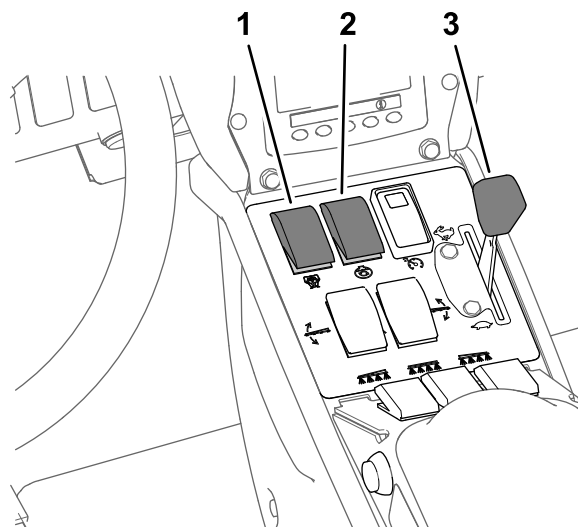

Figure 31

g192636

1. Sprayer-pump switch
2. Agitation switch
3. Throttle

9. Set the throttle to the FAST position (Figure 31).
10. Drive at the desired speed and then set the master section switch to the ON position to begin spraying (Figure 30).

Note: Use the master section switch to start and stop the flow of chemicals to the selected spray sections.

11. When finished spraying, set the master section switch to the OFF position to turn off all spray sections, then set the spray-pump switch to the OFF position.

Note: Raise the outer spray sections to the transport position and drive the sprayer to the cleaning area.

Important: Always raise the boom sections until they have moved completely into section-transport cradle forming the “X” transport position and the lift cylinders are fully retracted whenever you move the sprayer from 1 spraying area to another, or move to a storage or cleaning area.

Spraying in the Manual Mode

Note: This procedure assumes that the spray pump is on; refer to [Figure 31 in Spraying in the Application Rate Mode \(page 32\)](#).

1. Ensure that the sprayer system is adjusted for the active spray nozzles that you have selected; refer to [Setting the Section-Bypass Valves \(page 38\)](#).
2. Set the sprayer mode button to the Manual Mode ([Figure 32](#)).

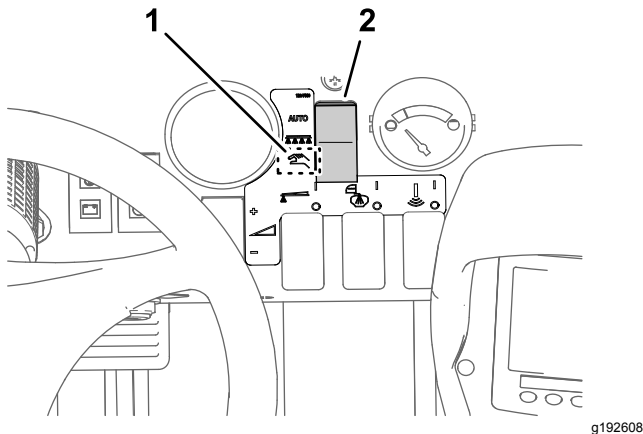

Figure 32

1. Manual mode position
2. Sprayer-mode switch

3. Set the master section switch to the OFF position; refer to [Figure 30 in Spraying in the Application Rate Mode \(page 32\)](#).
4. Adjust the throttle to the desired engine speed to spray; refer to [Figure 31 in Spraying in the Application Rate Mode \(page 32\)](#).
5. Drive to the spraying location.
6. Lower the sections into position.

7. Set the individual section switches, as needed, to the ON position; refer to [Figure 30 in Spraying in the Application Rate Mode \(page 32\)](#).
8. Use the application-rate switch to achieve the desired spray pressure as indicated in the nozzle-selection guide provided with the sprayer ([Figure 33](#)).

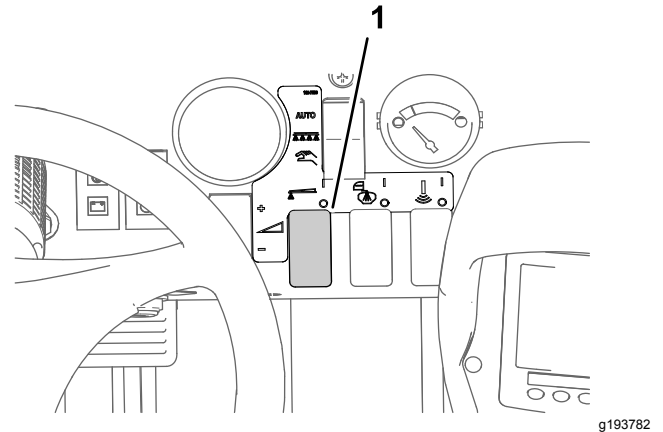

Figure 33

1. Application-rate switch

9. Drive at the desired speed and then set the master section switch to the ON position to begin spraying; refer to [Figure 30 in Spraying in the Application Rate Mode \(page 32\)](#).

Note: When the tank is nearly empty, the agitation may cause foaming in the tank. In this case, turn the agitation switch to the OFF position. Alternatively, you can add anti-foaming agent to the tank.

10. When you are finished spraying, set the master section switch to the OFF position to turn off all sections, then set the spray-pump switch to the OFF position.

Note: Return the sections to the transport position and drive the sprayer to the cleaning area.

Important: Always raise the sections until they have moved completely into section-transport cradle forming the “X” transport position and the section cylinders are fully retracted whenever you move the sprayer from 1 spraying area to another, or move to a storage or cleaning area.

Catch Test

Customer provided equipment: A graduated catch container (a container with 0.01 ml (1/2 fl. oz) increments is preferred) and stop watch.

Preparing for the Catch Test

1. Ensure that the sprayer tank is clean; refer to [Cleaning the Sprayer System \(page 37\)](#).
2. Fill the sprayer tank with at least 568 L (150 US gallons) of fresh water; refer to [Filling the Spray Tank \(page 31\)](#).
3. Ensure that the nozzles that you intend to test are in the active spray (down) position.
4. For machines operated in the application-rate mode, ensure that the knob for the section-bypass shutoff valve is in the closed position ([Figure 34](#)).

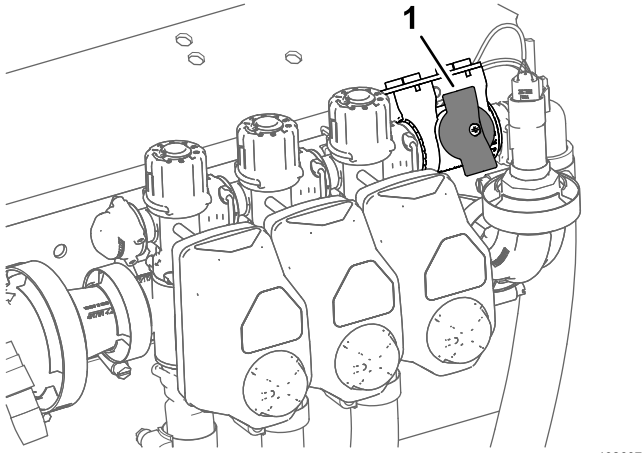

Figure 34

1. Section-bypass shutoff valve (closed position)
-
5. For machines operated in the application-rate mode, ensure that the section-bypass shutoff valve is closed ([Figure 34](#)).
 6. Engage the parking brake and start the engine.
Note: Allow the engine to warm for 10 minutes.
 7. For machines operated in the application-rate mode, perform the steps in Using the Test Speed; refer to the *Software Guide* for the Multi Pro 5800-D and 5800-G turf sprayers with ExcelaRate spray system.

Note: Set the simulated test speed between 4 km/h (2 mph) and 14 km/h (9 mph).

Performing a Catch Test

1. Set the spray section switch(es) to the ON position for the section(s) that you are testing.
2. Set the throttle to the FAST position.
3. Set the master section switch to the ON position.
4. Perform a 15-second catch test at 1 of the active spray nozzles.

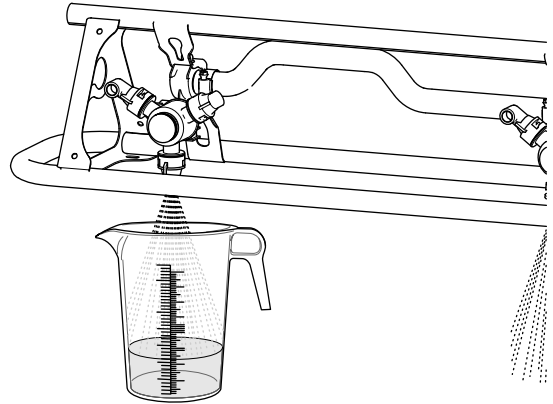

Figure 35

g193177

5. Shut off the master section switch, set the throttle to the slow position, shut off the spray pump, and shut off the engine.
6. Set the graduated container on a level surface and note the fluid volume ([Figure 36](#)).

Important: When you are reading the graduated container, you must set the container on a level surface.

Important: When you are reading the graduated container, read the fluid volume in the graduated container at the lowest point of the fluid-surface curve.

Important: Small errors reading the fluid volume in the graduated container will significantly impact the accuracy of the sprayer calibration.

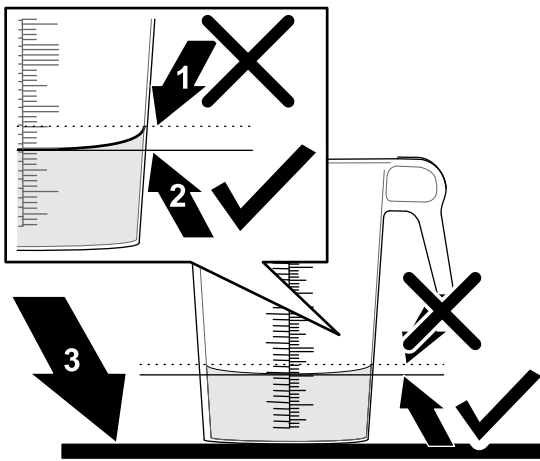

Figure 36

g193829

1. Highest point of the fluid-surface curve (**do not** measure here)
2. Lowest point of the fluid-surface curve (**measure here**)
3. Level surface

7. Compare the volume of water in the graduated container with the nozzle volume in the 15-second catch test table.

15-Second Catch Test Table

Nozzle Color	Milliliters collected in 15 seconds	Ounces collected in 15 seconds
Yellow	189	6.4
Red	378	12.8
Brown	473	16.0
Gray	567	19.2
White	757	25.6
Blue	946	32.0
Green	1,419	48.0

8. If the fluid level in the graduated catch container is 7.4 ml (1/4 fl oz) more or less than the nozzle volume in the 15-second catch test table, perform 1 of the following:
 - Perform a flow calibration, or replace worn nozzles and perform a flow calibration; refer to the flow calibration procedure in the *Software Guide* for the Multi Pro 5800-D and 5800-G turf sprayer with ExcelaRate spray system.
 - Calibrate the agitation bypass valve, or replace worn nozzles and calibrate the agitation bypass valve; refer to [Calibrating the Agitation-Bypass Valve \(page 39\)](#).

Taking Proper Turf Care Precautions while Operating in Stationary Modes

Important: Under some conditions, heat from the engine, radiator, and muffler can damage grass when operating the sprayer in a stationary mode. Stationary modes include tank agitation, hand spraying with a spray gun, or using a walking boom.

Use the following precautions:

- **Avoid** stationary spraying when conditions are very hot and/or dry, as turf can be more stressed during these periods.
- **Avoid** parking on the turf while stationary spraying. Park on a cart path whenever possible.
- **Minimize** the amount of time the machine is left running over any particular area of turf. Both time and temperature affect how much the grass may be damaged.
- **Set the engine speed as low as possible** to achieve the desired pressure and flow. This minimizes the heat generated and the air velocity from the cooling fan.
- **Allow heat to escape** upward from the engine compartment by raising the seat assemblies during stationary operation rather than being forced out under the vehicle.

Spraying Tips

- Do not overlap areas that you have previously sprayed.
- Watch for plugged nozzles. Replace all worn or damaged nozzles.
- Use the master section switch to stop the spray flow before stopping the sprayer. Once it stops, use the engine-throttle control to hold the engine speed up to keep the agitation running.
- You will obtain better results if the sprayer is moving when you turn the spray sections on.

Unclogging a Nozzle

If a nozzle becomes clogged while you are spraying, clean the nozzle as follows:

1. Stop the sprayer on a level surface, shut off the engine, and engage the parking brake.
2. Set the master section switch to the OFF position and then set the sprayer-pump switch to the OFF position.

3. Remove the clogged nozzle and clean it using a spray bottle of water and a toothbrush.
4. Install the nozzle.

Selecting a Nozzle

Note: Refer to the nozzle-selection guide that is available through your Authorized Toro Dealer.

The turret bodies can accept up to 3 different nozzles. To select the desired nozzle perform the following:

1. Stop the sprayer on a level surface, shut off the engine, and engage the parking brake.
2. Set the master section switch to the OFF position and set the spray-pump switch to the OFF position.
3. Rotate the turret of the nozzles in either direction to the correct nozzle.
4. For machines operated in the application rate mode, perform a flow calibration; refer to the Software Guide for the Multi Pro 5800-D and 5800-G turf sprayers with ExcelsaRate spray system.

Cleaning the Sprayer System

Draining the Tank

1. Stop the sprayer, engage the parking brake, and shut off the engine.
2. Locate the tank-drain valve at the left, rear fender of the machine (Figure 37).

Note: The drain valve is attached to the drain-valve bracket that is mounted to the left, rear fender.

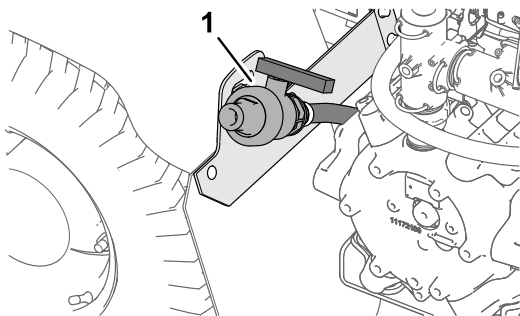

Figure 37

g191084

1. Drain valve (sprayer tank)

3. Lift the valve until the mount studs of the valve clear the slots in the drain-valve bracket, and move the valve rearward (Figure 38A).

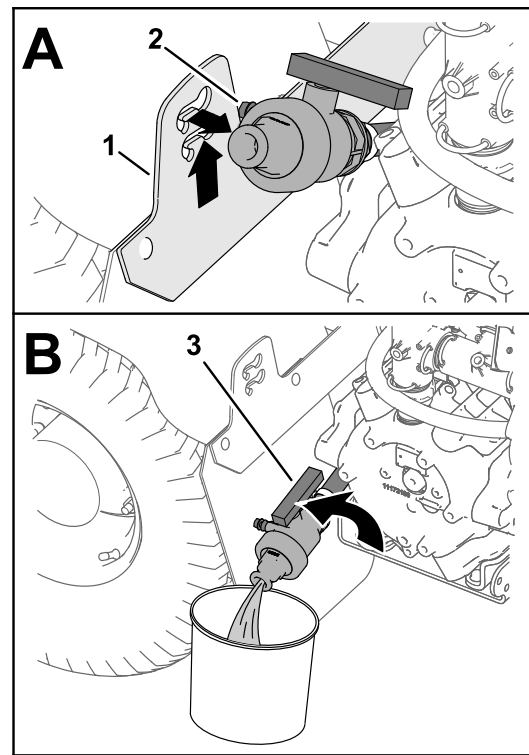

Figure 38

g191083

1. Drain-valve bracket
2. Mount studs (drain valve)
3. Drain valve handle (open position)

4. Align the end of the valve with the drain container and rotate valve handle to the open position (Figure 38B).
5. When the tank has drained completely, rotate the drain-valve handle to the closed position and assemble the valve onto the drain-valve bracket (Figure 38B and Figure 38A).

Important: Dispose of the sprayer tank chemicals according to local codes and the material manufacturer's instructions.

Cleaning the Sprayer

Important: You must always empty and clean the sprayer and any installed spray accessories immediately after each use. Failure to do so may cause the chemicals to dry or thicken in the lines, clogging the pump and other components.

Toro recommends using the approved Clean Rinse Kit for this machine. Contact your Authorized Toro Dealer for more information.

Clean the spray system and any installed spray accessories after **each** spraying session. To properly clean the spray system:

- Use 3 separate rinses.

- Use the cleaners and neutralizers as recommended by the chemical manufacturers.
- Use pure, clean water (no cleaners or neutralizers) for the **last** rinse.

1. Fill the tank with at least 190 L (50 US gallons) of clean, fresh water and close the cover.

Note: You can use a cleaning/neutralizing agent in the water as needed. On the final rinse, use only clean, clear water.

2. Lower the outer spray sections into the spray position.
3. Start the engine and move the throttle lever to a higher engine speed.
4. Ensure that the agitation switch is in the ON position.
5. Set the spray-pump switch to the ON position and use the application-rate switch to increase the pressure to a high setting.
6. Set the individual section switches and master section switch to the ON positions to begin spraying.
7. Allow all of the water in the tank to spray out through the nozzles.
8. Check the nozzles to ensure that they are all spraying correctly.
9. Set the master section switch to the OFF position, set the spray-pump switch to the OFF position, and shut off the engine.
10. Repeat steps 1 through 9 at least 2 more times to ensure that the spray system is fully cleaned.

Important: You must always complete this procedure at least 3 times to ensure that the spray system and spray accessories are fully clean, preventing damage to the system.

11. Clean the strainer; refer to [Cleaning the Suction Filter \(page 27\)](#).

Important: If you used wettable powder chemicals, clean the strainer after each tank.

12. Using a garden hose, rinse off the outside of the sprayer with clean water.
13. Remove the nozzles and clean them by hand.

Note: Replace damaged or worn nozzles.

Setting the Section-Bypass Valves

Manual Mode Only

Important: When operating in application rate mode, you must set the section-bypass valves to the closed position.

Before using the sprayer for the first time, if you change the nozzles, or as needed, calibrate the sprayer flow, speed, and set the section bypass; refer to [Setting the Section-Bypass Valves \(page 38\)](#).

Note: Calibrate the section valves whenever you change the nozzles.

Select an open flat area to perform this procedure.

1. Fill the spray tank halfway with clean water.
2. Lower the spray sections.
3. Engage the parking brake.
4. Set the spray control switch to manual.
5. Set the 3 section switches to the ON position, but leave the master section switch in the OFF position.
6. Set the spray-pump switch to the ON position, and turn on the agitation.
7. On the InfoCenter, navigate to the Calibration screen and select Test Speed; refer to *Simulating a Test Speed in the Software Guide* for the Multi Pro 5800-D and 5800-G turf sprayer with ExcelaRate spray system.
 - A. Press buttons 3 or 4 to raise or lower the simulated speed to 5.6 km/h (3.5 mph).
 - B. Press button 4 to toggle ON test speed simulation.
 - C. Press button 5 to save and exit the TEST SPEED screen.
8. Using the application-rate switch, adjust the application rate according to the table that follows.

Nozzle Application Rate Table

Nozzle Color	SI (Metric)	English	Turf
Yellow	159 L/ha	17 gpa	0.39 gpk
Red	319 L/ha	34 gpa	0.78 gpk
Brown	394 L/ha	42 gpa	0.96 gpk
Gray	478 L/ha	51 gpa	1.17 gpk
White	637 L/ha	68 gpa	1.56 gpk
Blue	796 L/ha	85 gpa	1.95 gpk
Green	1,190 L/ha	127 gpa	2.91 gpk

- Turn off the left-section switch and adjust the section-bypass knob (Figure 39) until the rate displayed is at the previous level according to the table.

Note: The numbered indicators on the bypass knob and needle are for reference only.

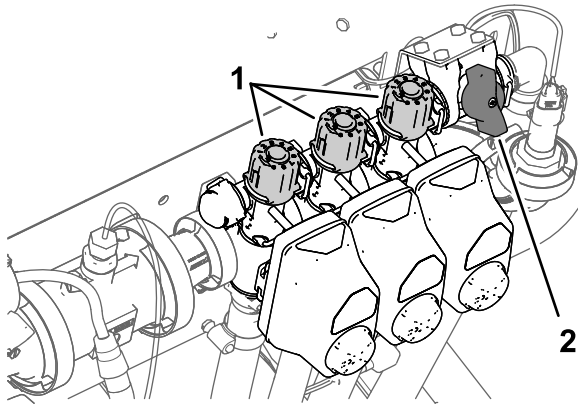

Figure 39

g191413

- Section-bypass adjustment knobs
- Sections-bypass shutoff valve

- Turn on the left-section switch and turn off the right-section switch.
- Adjust the right section-bypass knob (Figure 39) until the rate displayed is at the previous level according to the table.
- Turn on the right-section switch and turn off the center-section switch.
- Adjust the center section-bypass knob (Figure 39) until the rate displayed is at the previous level according to the table.
- Turn off the master section switch.
- Turn off the spray pump.

Agitation-Bypass Valve Knob Position

- The agitation-bypass valve is in the full open position as shown in Figure 40A.
- The agitation-bypass valve is in the closed (0) position as shown in Figure 40B.
- The agitation-bypass valve is in an intermediate (adjusted relative to the pressure gauge for the sprayer system) position as shown in Figure 40C.

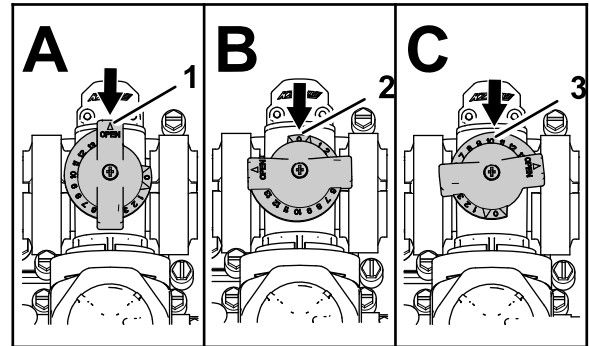

Figure 40

g214029

- Open
- Closed (0)
- Intermediate position

Calibrating the Agitation-Bypass Valve

Service Interval: Yearly—Calibrate the agitation-bypass valve.

Important: If you have the ExcelsaRate™ Spray System installed turn the selection switch to **MANUAL** mode.

- Select an open, flat area to perform this procedure.
- Fill the spray tank half full with clean water.
- Verify that the agitation-control valve is open.

Note: If it has been adjusted, open it completely at this time.

- Engage the parking brake and start the engine.
- Set the spray-pump switch and the agitation switch to the ON position.
- Turn the master section switch to the OFF position.
- Move the throttle lever to the FAST position.
- Use the application-rate switch to adjust the sprayer-system pressure to 689 kPa (100 psi).
- Turn the agitation switch to the OFF position and read the pressure gauge.

- If the pressure gauge indicates 689 kPa (100 psi), the agitation-bypass valve is properly calibrated.
- If the pressure gauge indicates differently, continue to the next step.

10. Adjust the agitation-bypass valve (Figure 41) on the backside of the agitation valve until the sprayer system pressure indicated on the gauge indicates 689 kPa (100 psi).

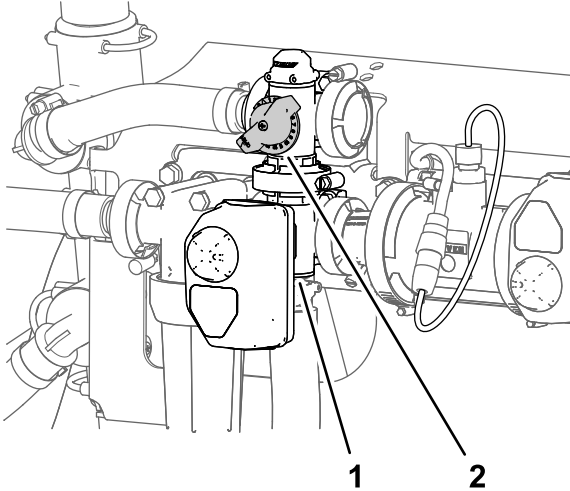

Figure 41

g191362

1. Actuator (agitation valve)
2. Agitation-bypass valve

11. Turn the spray-pump switch to the OFF position.
12. Move the throttle lever to the IDLE/SLOW position and turn the key switch to the OFF position.

Locating the Spray Pump

The spray pump is located near the back of the tank on the left side (Figure 42).

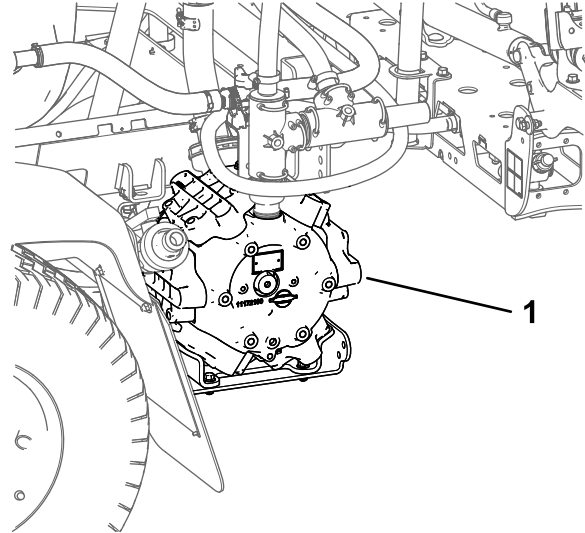

Figure 42

g194233

1. Spray pump

Hauling the Machine

- Use full-width ramps for loading the machine onto a trailer or truck.
- Tie the machine down securely.

Transporting the Sprayer

For moving the sprayer long distances, use a trailer. Secure the sprayer to the trailer. Also, ensure that the outer boom sections are tied down and secure. Figure 43 and Figure 44 illustrate the tie-down points.

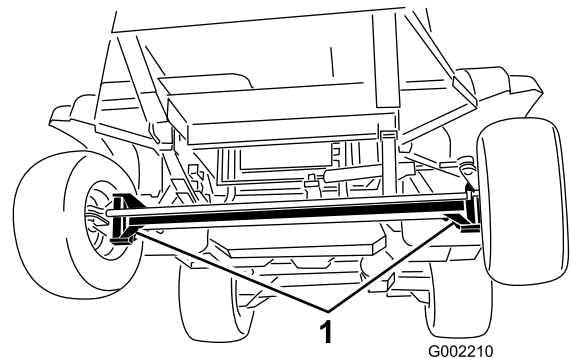

Figure 43

G002210

g002210

1. Tie-down points

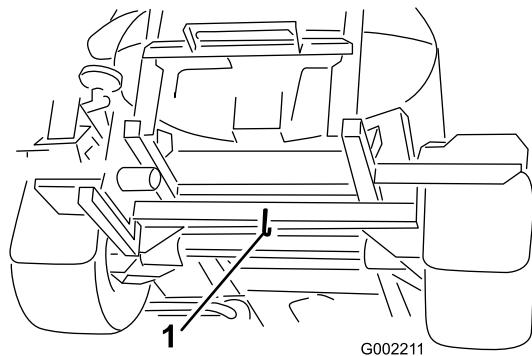

Figure 44

1. Rear tie-down point

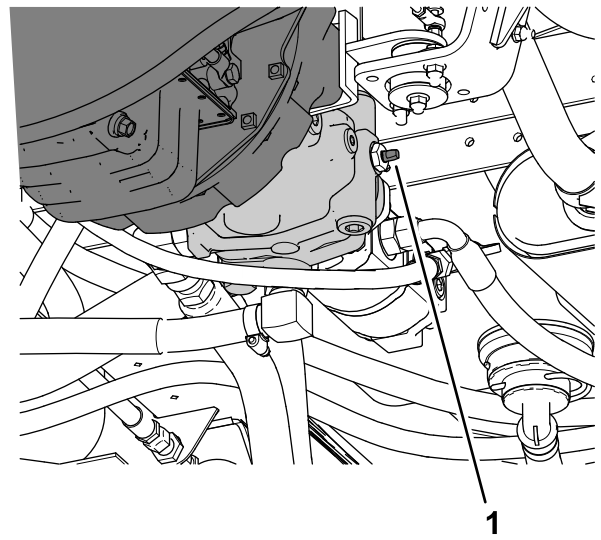

Figure 45

1. Tow valve

Towing the Sprayer

In case of an emergency, the sprayer can be towed for a short distance after you open the tow valve. However, we do not recommend this as a standard procedure.

⚠ WARNING

Towing at excessive speeds could cause a loss of steering control, resulting in personal injury.

Never tow the sprayer at faster than 4.8 kph (3 mph).

Towing the sprayer is a 2-person job. If the machine must be moved a considerable distance, transport it on a truck or trailer; refer to [Hauling the Machine \(page 40\)](#).

1. Allow the exhaust system to cool completely.
2. Remove the undercarriage shroud; refer to [Removing the Undercarriage Shroud \(page 49\)](#).
3. Rotate the tow valve ([Figure 45](#)) 90° in either direction to open the tow valve.

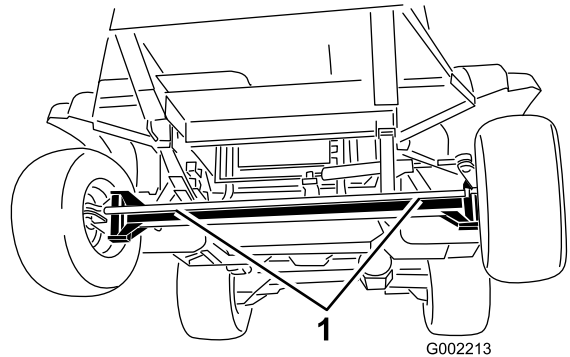

Figure 46

1. Front towing points

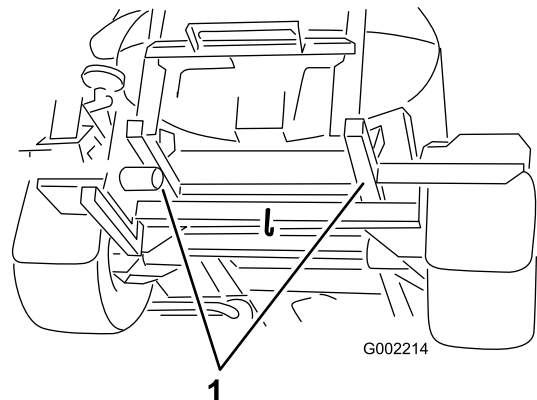

Figure 47

1. Rear towing points

5. Release the parking brake.
6. Tow the sprayer at less than 4.8 kph (3 mph).
7. When finished, close the tow valve and torque it to 7 to 11 N·m (5 to 8 ft-lb).

Important: Before returning the machine to service, install the undercarriage shroud; refer to [Installing the Undercarriage Shroud \(page 50\)](#).

Spray Filter Recommendations

Selecting a Suction Filter

Standard Equipment: 50 mesh suction filter (blue)

Use the suction filter table to identify the screen mesh for the spray nozzles you are using based on chemicals products or solutions with a viscosity equivalent to water.

Suction Filter Table

Spray Nozzle Color Code (flow rate)	Screen Mesh Size*	Filter Color Code
Yellow (0.2 gpm)	50	Blue
Red (0.4 gpm)	50	Blue
Brown (0.5 gpm)	50 (or 30)	Blue (or green)
Gray (0.6 gpm)	30	Green
White (0.8 gpm)	30	Green
Blue (1.0 gpm)	30	Green
Green (1.5 gpm)	30	Green

*The mesh size of the suction filters in this table are based on spray chemicals or solutions with the viscosity equivalent to water.

Important: When you spray with higher viscosity (thicker) chemical products or solutions with wettable powders, you may need to use an coarser screen mesh for the optional suction filter; refer to [Figure 48](#).

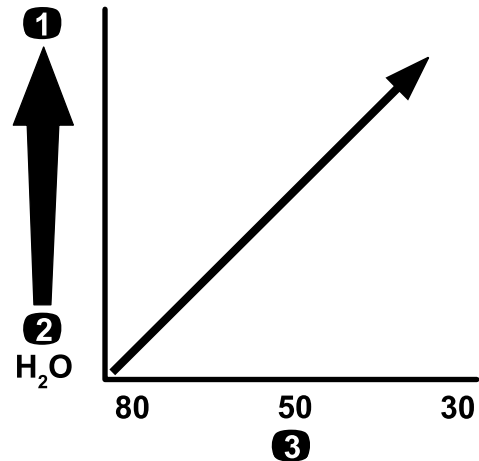

Figure 48

Mesh size—chemical or solution viscosity

1. Higher-viscosity chemicals
2. Lower-viscosity chemicals
3. Screen mesh size or solutions

g214212

When you spray at a higher application rate, consider using a coarser optional suction-filter mesh; refer to [Figure 49](#).

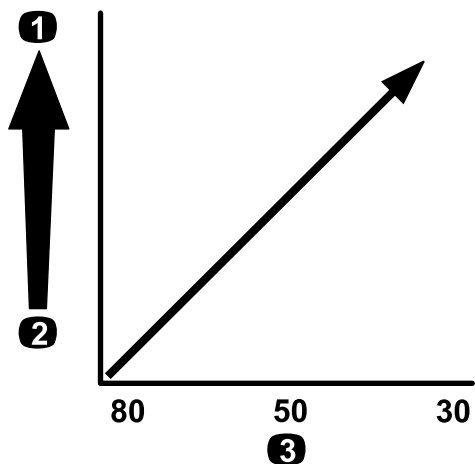

Figure 49

Mesh size—application rate

1. Higher application rate
2. Lower application rate
3. Screen mesh size

g214214

Pressure Filter Table (cont'd.)

Spray Nozzle Color Code (flow rate)	Screen Mesh Size*	Filter Color Code
As required for high viscosity chemicals or solutions or high application rates	16	Brown
*The mesh size of the pressure filters in this table are based on spray chemicals or solutions with the viscosity equivalent to water.		

Important: When you spray with higher viscosity (thicker) chemical products or solutions with wettable powders, you may need to use a coarser screen mesh for the optional pressure-filter; refer to [Figure 50](#).

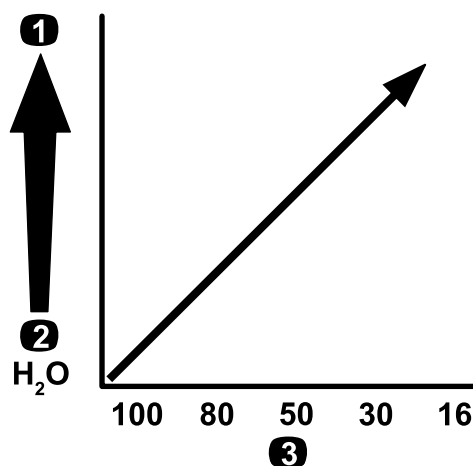

Figure 50

Mesh size—chemical or solution viscosity

1. Higher-viscosity chemicals or solutions
2. Lower-viscosity chemicals or solutions
3. Screen mesh size

g214211

Selecting a Pressure Filter

Available screen sizes include:

Standard Equipment: 50 mesh suction filter (blue)

Use the pressure filter table to identify the screen mesh for the spray nozzles you are using based on chemicals products or solutions with a viscosity equivalent to water.

Pressure Filter Table

Spray Nozzle Color Code (flow rate)	Screen Mesh Size*	Filter Color Code
As required for low viscosity chemicals or solutions or low application rates	100	Green
Yellow (0.2 gpm)	80	Yellow
Red (0.4 gpm)	50	Blue
Brown (0.5 gpm)	50	Blue
Gray (0.6 gpm)	50	Blue
White (0.8 gpm)	50	Blue
Blue (1.0 gpm)	50	Blue
Green (1.5 gpm)	50	Blue
As required for high viscosity chemicals or solutions or high application rates	30	Red

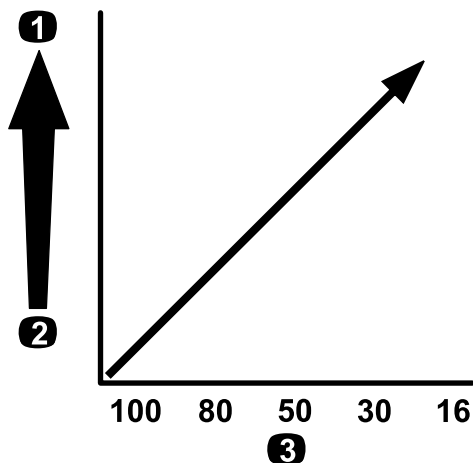

Figure 51

Mesh size—application rate

1. Higher application rate
2. Lower application rate
3. Screen mesh size

g214240

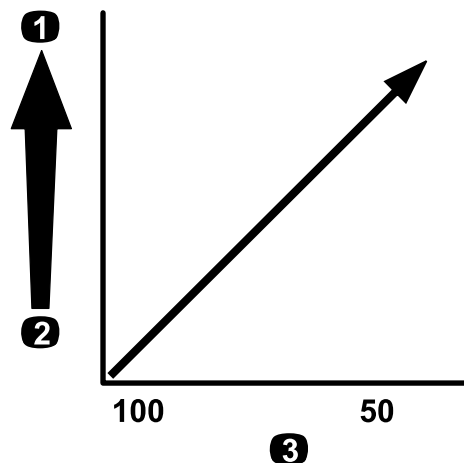

Figure 52

Mesh size—chemical or solution viscosity

1. Higher-viscosity chemicals or solutions
2. Lower-viscosity chemicals or solutions
3. Screen mesh size

g214245

Selecting a Nozzle-Tip Filter (Optional)

Note: The use the optional nozzle-tip filter to protect the spray-nozzle tip and increase its service life.

Use the nozzle-tip filter table to identify the screen mesh for the spray nozzles you are using based on chemicals products or solutions with a viscosity equivalent to water.

Nozzle-Tip Filter Table

Spray Nozzle Color Code (flow rate)	Filter Mesh Size*	Filter Color Code
Yellow (0.2 gpm)	100	Green
Red (0.4 gpm)	50	Blue
Brown (0.5 gpm)	50	Blue
Gray (0.6 gpm)	50	Blue
White (0.8 gpm)	50	Blue
Blue (1.0 gpm)	50	Blue
Green (1.5 gpm)	50	Blue

*The mesh size of the nozzle filters in this table are based on spray chemicals or solutions with the viscosity equivalent to water.

Important: When you spray with higher viscosity (thicker) chemical products or solutions with wettable powders, you may need to use a coarser screen mesh for the optional tip-filter; refer to [Figure 52](#).

When you spray at a higher application rate, consider using an courser tip-filter mesh; refer to [Figure 53](#).

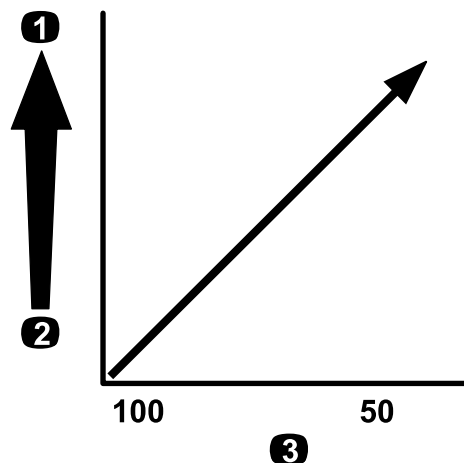

Figure 53

Mesh size—application rate

1. Higher application rate
2. Lower application rate
3. Screen mesh size

g214245

Maintenance

Download a free copy of the electrical or hydraulic schematic by visiting www.Toro.com and searching for your machine from the Manuals link on the home page.

Note: Determine the left and right sides of the machine from the normal operating position.

Recommended Maintenance Schedule(s)

Maintenance Service Interval	Maintenance Procedure
After the first 5 hours	<ul style="list-style-type: none"> • Replace the hydraulic-fluid filters.
After the first 8 hours	<ul style="list-style-type: none"> • Torque the wheel-lug nuts. • Change the rear planetary-gearbox fluid. • Check the fan/alternator belt.
After the first 50 hours	<ul style="list-style-type: none"> • Change the engine oil and oil filter. • Check the fuel lines and connections.
After the first 100 hours	<ul style="list-style-type: none"> • Follow the guidelines for breaking in a new sprayer.
After the first 200 hours	<ul style="list-style-type: none"> • Pack the front wheel bearings.
Before each use or daily	<ul style="list-style-type: none"> • Check the tire air pressure. • Check the brakes. • Clean the suction filter. • Clean the pressure filter. • Check the tank straps. • Check the air cleaner. • Check the engine oil. • Check the coolant level. • Check the hydraulic-fluid level.
Every 50 hours	<ul style="list-style-type: none"> • Lubricate the pump. • Lubricate all grease fittings. • Lubricate the front steering and suspension. • Lubricate all grease fittings. • Check the battery-cable connections.
Every 100 hours	<ul style="list-style-type: none"> • Lubricate the boom hinges. • Replace the air-filter element. • Torque the wheel-lug nuts. • Inspect the condition and wear of the tires. • Check the cooling-system hoses for wear and damage. • Check the fan/alternator belt.
Every 150 hours	<ul style="list-style-type: none"> • Change the engine oil (including synthetic oil) and oil filter.
Every 200 hours	<ul style="list-style-type: none"> • Check front wheel toe-in. • Inspect all hoses and connections for damage and proper attachment. • Clean the radiator fins. • Clean the flow meter (more often when using wettable powders).

Maintenance Service Interval	Maintenance Procedure
Every 400 hours	<ul style="list-style-type: none"> • Grease the actuator-rod bearings. • Complete all yearly maintenance procedures specified in the engine owner's manual. • Check the fuel lines and connections. • Replace the fuel-filter canister. • Replace the in-tank fuel filter. • Drain and clean the fuel tank. • Pack the front wheel bearings. • Change the planetary-gearbox fluid. • Check the coolant (as directed by the manufacturer) and change if necessary. • Replace the hydraulic-fluid filters. • Change the hydraulic fluid. • Inspect the O-rings in the valve assemblies and replace them if necessary. • Change the suction filter. • Change the pressure filter. • Inspect the nylon pivot bushings. • Inspect the pump diaphragm and replace if necessary • Inspect the pump check valves and replace if necessary
Yearly	<ul style="list-style-type: none"> • Flush the sprayer with clean water. • Calibrate the agitation-bypass valve.

Important: Refer to your engine owner's manual for additional maintenance procedures.

Daily Maintenance Checklist

Duplicate this page for routine use.

Maintenance Check Item	For the week of:						
	Monday	Tuesday	Wednesday	Thursday	Friday	Saturday	Sunday
Check the brake and parking-brake operation.							
Check the neutral-lockout-switch operation.							
Check the fuel level.							
Check the engine-oil level.							
Check the hydraulic-fluid level.							
Check the coolant level.							
Inspect the air filter.							
Inspect the radiator and oil cooler for debris.							
Check for any unusual engine noises.							
Check for any unusual operating noises.							
Check the tire air pressure.							
Check for fluid leaks.							
Check all hydraulic and fluid hoses for damage, kinks, or wear.							
Check the instrument operation.							
Check the accelerator operation.							
Clean the suction strainer.							
Lubricate all grease fittings ¹							
Touch up any damaged paint.							

¹Immediately after **every** washing, regardless of the interval listed

Notation for Areas of Concern

Inspection performed by:		
Item	Date	Information
1		
2		
3		
4		
5		
6		
7		
8		

Pre-Maintenance Procedures

⚠ CAUTION

If you leave the key in the starter switch, someone could accidentally start the engine and seriously injure you or other bystanders.

Remove the key from the starter switch before you do any maintenance.

Raising the Sprayer

Whenever running the engine for routine maintenance and/or engine diagnostics, the rear wheels of the sprayer should be 25 mm (1 inch) off the ground with the rear axle supported on jack stands.

⚠ DANGER

A sprayer on a jack may be unstable and slip off of the jack, injuring anyone beneath it.

- Always remove the key from the starter switch before getting off the sprayer.
- Block the tires when the sprayer is on a jack.
- Support the machine with jack stands.

The jacking point at the front of the sprayer is under the front axle, directly under the leaf springs (Figure 54).

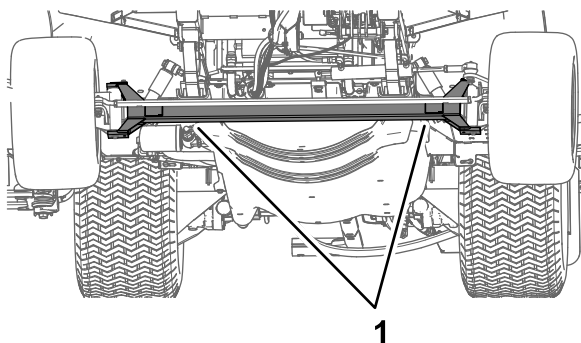

Figure 54

g203110

1. Front jacking points

The jacking point at the rear of the sprayer is on the rear side where the boom supports are located (Figure 55).

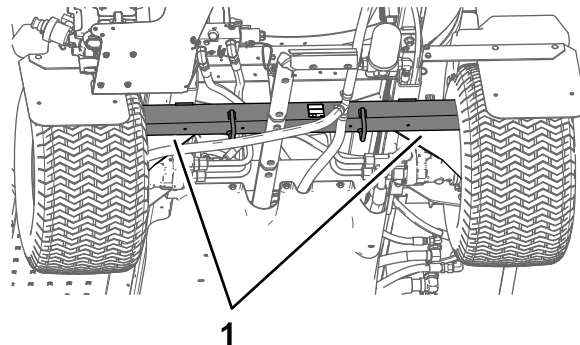

Figure 55

g203111

1. Rear jacking points

Accessing the Engine

Removing the Forward Heat Shield

1. Engage the parking brake, shut off the spray pump, shut off the engine, and remove the key.
2. Raise the front and back of the machine and support it with jack stands; refer to [Raising the Sprayer](#) (page 48).
3. Remove the 6 hex-head bolts and 6 washers that secure the front, forward heat shield to the chassis and remove the shield (Figure 56).

Note: Retain the bolts, washers, and heat shield for installation in [Installing the Forward Heat Shield](#) (page 49).

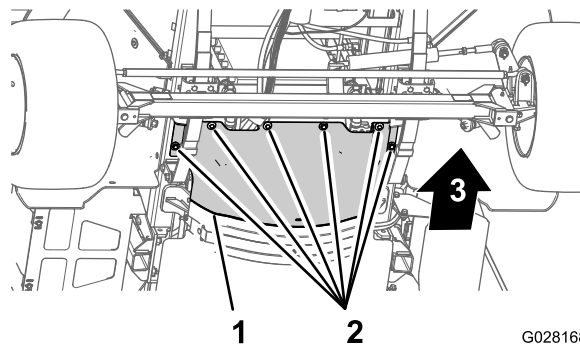

Figure 56

G028168

g028168

1. Forward heat shield
2. Hex-head bolts and washers

Installing the Forward Heat Shield

1. Align the rear flange of the forward heat shield over the forward flange of the rear heat shield (Figure 57).

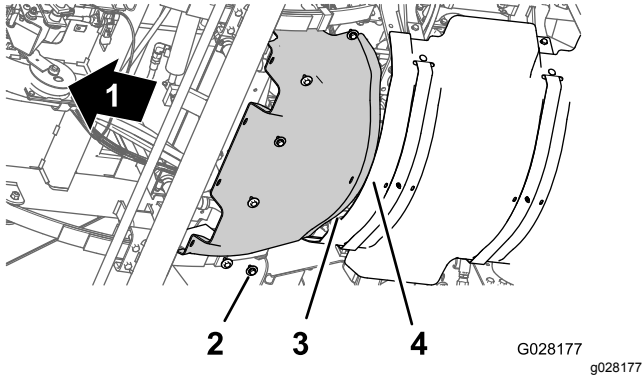

Figure 57

- | | |
|-------------------------------|--------------------------------------|
| 1. Front of the machine | 3. Rear flange (forward heat shield) |
| 2. Hex-head bolts and washers | 4. Forward flange (rear heat shield) |

2. Align the holes in the forward heat shield with the threaded holes in the chassis (Figure 57).
3. Assemble the forward heat shield to the machine with the 6 hex-head bolts and 6 washers (Figure 57) that you removed in step 3 of [Removing the Forward Heat Shield](#) (page 48).
4. Torque the bolts to 1978 to 2542 N·cm (175 to 115 in·lb).
5. Remove the jack stands and lower the machine.

Removing the Undercarriage Shroud

1. Remove the 5 flange-head bolts (5/16 x 7/8 inch) and 5 washers (5/16 inch) that secure the rear of the undercarriage shroud to the chassis of the machine (Figure 58).

Note: Retain the flange-head bolts and washers for installation in step 5 of [Installing the Undercarriage Shroud](#) (page 50).

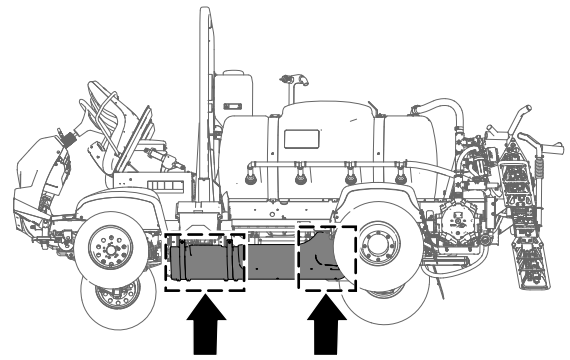

g189584

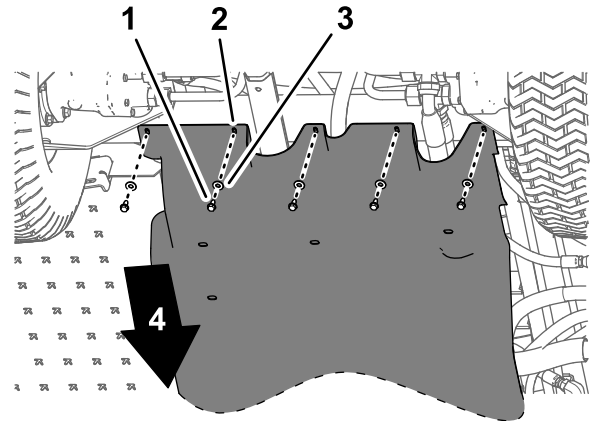

g189585

Figure 58

- | | |
|--|-------------------------|
| 1. Flange-head bolts (5/16 x 7/8 inch) | 3. Washers (5/16 inch) |
| 2. Undercarriage shroud | 4. Front of the machine |

2. Remove the 4 flange locknuts (5/16 inch) from the bolts and carriage bolt that secure the mounting tabs of the undercarriage shroud to the engine-mount brackets of the machine (Figure 59).

Note: Do not remove the bolts from the machine. Retain the flange locknuts for installation in step 3 of [Installing the Undercarriage Shroud](#) (page 50).

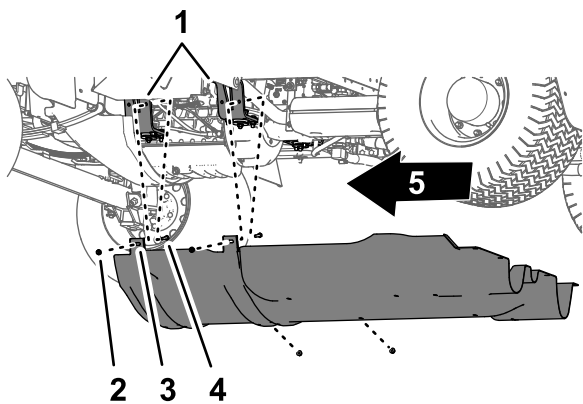

Figure 59

g189583

- | | |
|--|--------------------------------|
| 1. Engine mount | 4. Flange locknuts (5/16 inch) |
| 2. Bolt—shown for clarity; do not remove | 5. Front of the machine |
| 3. Mounting tabs (undercarriage shroud) | |

3. Move the mounting tabs off the bolts that secure the undercarriage shroud to the engine-mount brackets.
4. Remove the undercarriage shroud from the machine (Figure 58 and Figure 59).

Installing the Undercarriage Shroud

1. Align the undercarriage shroud to the bottom chassis of the machine; refer to Figure 59 in Removing the Undercarriage Shroud (page 49).
2. Move the mounting tabs of the undercarriage shroud over the bolts and carriage bolt at the engine-mount brackets of the machine; refer to Figure 59 in Removing the Undercarriage Shroud (page 49).
3. Assemble the undercarriage shroud to the engine-mount brackets and bolts (Figure 59) with the 4 flange locknuts (5/16 inch) that you removed in step 2 of Removing the Undercarriage Shroud (page 49).
4. Align the holes in the rear part of the undercarriage shroud with the holes in the chassis; refer to Figure 58 in Removing the Undercarriage Shroud (page 49).
5. Assemble the rear part of the undercarriage shroud to the chassis (Figure 58) with the 5 flange-head bolts (5/16 x 7/8 inch) and 5 washers (5/16 inch) that you removed in step 1 of Removing the Undercarriage Shroud (page 49).
6. Torque the nuts and bolts to 1129 to 1582 N·cm (100 to 140 in-lb).

Removing the Seat-Base-Access Panel

1. Remove the 2 flanged-head bolts that secure the seat-base-access panel to the seat base (Figure 60).

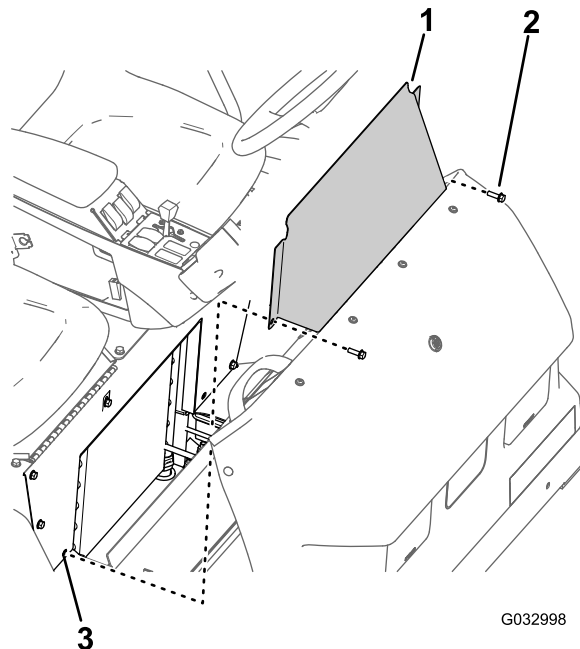

Figure 60

G032998

g032998

- | | |
|---------------------------|---------------------|
| 1. Seat-base-access panel | 3. Hole (seat base) |
| 2. Flanged-head bolt | |

2. Remove the seat-base-access panel from the machine (Figure 60).

Installing the Seat-Base-Access Panel

1. Align the holes in the seat-base-access panel with the holes in the seat base (Figure 60).
2. Assemble the seat-base-access panel to the seat base with the 2 flanged-head bolts (Figure 60) that you removed in step 1 of Removing the Seat-Base-Access Panel (page 50).
3. Torque the bolts to 1975 to 2542 N·cm (175 to 225 in-lb).

Lubrication

Greasing the Spray Pump

Service Interval: Every 50 hours—Lubricate the pump.

Every 50 hours/Yearly (whichever comes first)

Grease Type: Mobil XHP 461.

1. Wipe the 2 remote grease fitting clean (Figure 61).

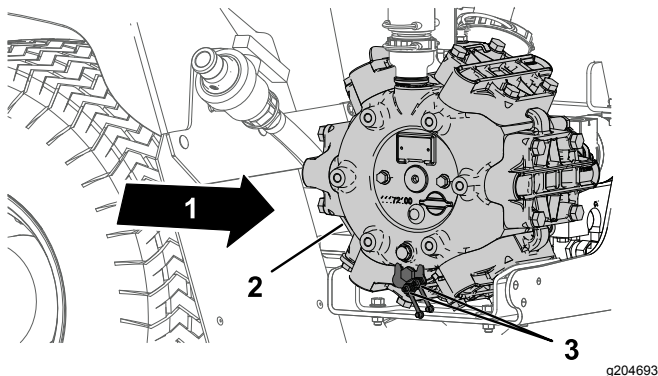

Figure 61

1. Back of the machine
2. Spray pump
3. Grease point (2)

2. Pump grease into the remote grease fitting (Figure 61).
3. Wipe off the excess grease.

Greasing the Front Steering and Suspension

Service Interval: Every 50 hours—Lubricate the front steering and suspension.

Every 50 hours/Yearly (whichever comes first)

Grease Type: No. 2 lithium grease. Toro Premium All-Purpose Grease is available from your Toro Distributor.

- Steering cylinder—2 grease fittings at each rod end of the cylinder
 - Steering rod—2 grease fittings at each rod end
 - Spindle pivot—2 grease fittings at each side of the machine
1. Wipe the grease fittings clean (Figure 62 and Figure 63).
 2. Pump grease into the grease fittings (Figure 62 and Figure 63).
 3. Wipe off excess grease.

Note: The grease fittings positions are illustrated in Figure 62.

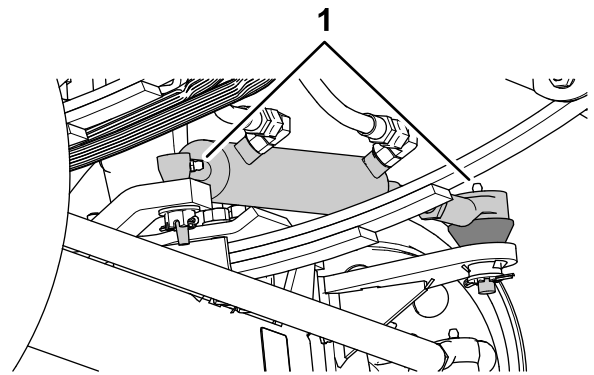

Figure 62

1. Grease fitting

g187456

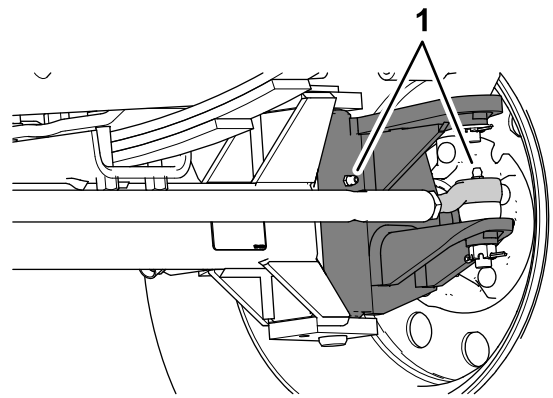

Figure 63

There are 2 fittings at each front wheel.

1. Grease fittings

g187457

Greasing the Boom Hinges

Service Interval: Every 100 hours

Important: If the boom hinge is washed with water, clear all water and debris from the hinge assembly and fresh grease must be applied.

Grease Type: No. 2 lithium grease.

1. Wipe the grease fittings clean so that foreign matter cannot be forced into the bearing or bushing.
2. Pump grease into the bearing or bushing at each fitting (Figure 64).

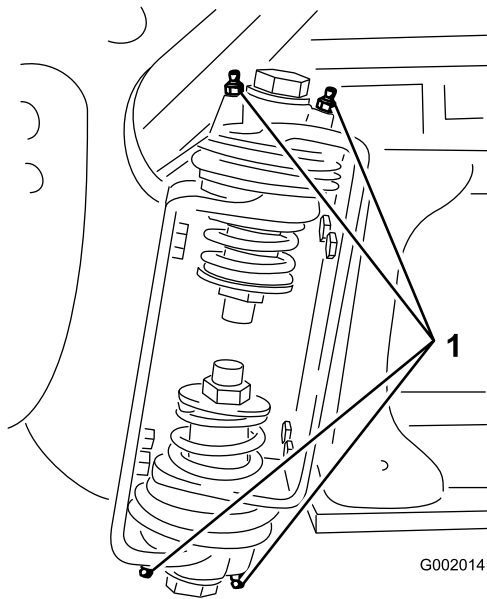

Figure 64
Right Boom

G002014

g002014

1. Grease fitting

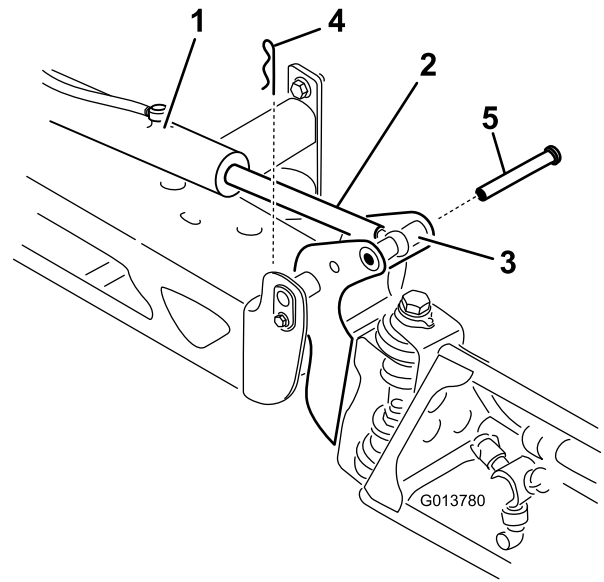

Figure 65

g013780

1. Actuator
2. Actuator rod
3. Boom-pivot-pin housing
4. Hairpin
5. Clevis pin

3. Wipe off excess grease.
4. Repeat the procedure for each boom pivot.

5. Swivel the rod-end bearing and apply grease into the bearing ([Figure 66](#)).

Note: Wipe off excess grease.

Greasing the Actuator-Rod Bearings

Service Interval: Every 400 hours/Yearly (whichever comes first)

Grease Type: No. 2 lithium grease.

1. Lower the outer spray sections to the SPRAY position.
2. Remove the hairpin from the clevis pin ([Figure 65](#)).
3. Lift up on the section, remove the clevis pin, and slowly lower the section to the ground ([Figure 65](#)).
4. Inspect the clevis pin for damage, and replace it if necessary.

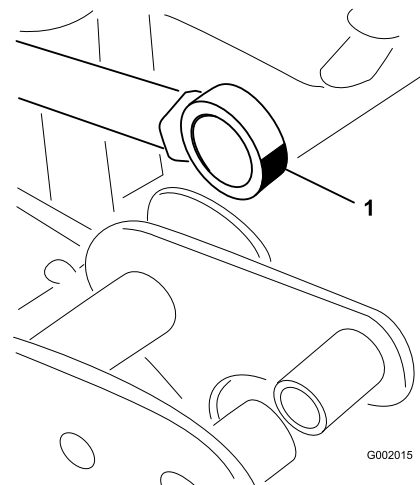

Figure 66
Right Boom

G002015

g002015

1. Grease the rod-end bearing

6. Lift the spray section to align the pivot with the actuator rod.
7. While supporting the spray section, insert the clevis pin through both boom pivot and actuator rod ([Figure 65](#)).
8. With the pin in place, release the spray section and secure the clevis pin with the hairpin removed previously.

- Repeat steps 2 through 8 to the actuator-rod bearing at the other side of the machine.

Engine Maintenance

Checking the Air Cleaner

Service Interval: Before each use or daily—Check the air cleaner. Service the air cleaner more frequently if operating conditions are extremely dusty or sandy.

- Engage the parking brake, shut off the spray pump, shut off the engine, and remove the key.
- Tilt the passenger seat forward and align the prop rod into the detent in the prop-rod-guide slot.
- Clean the dust cap and air-cleaner body (Figure 67).

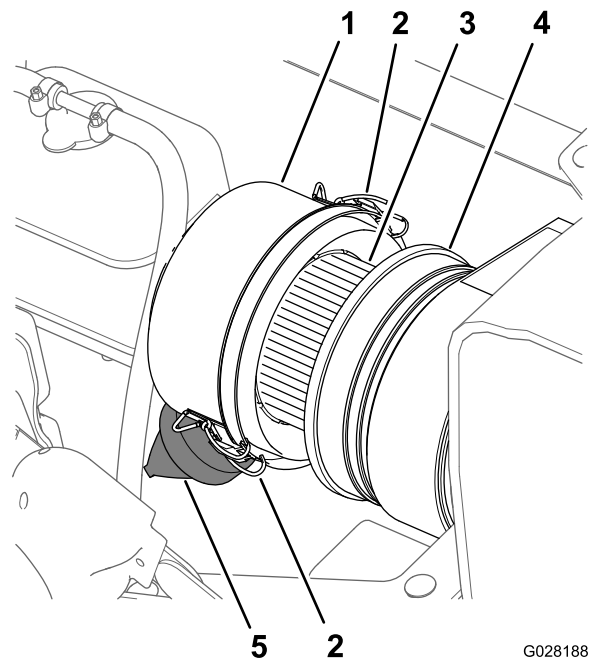

Figure 67

G028188
g028188

- | | |
|-----------------------|---------------------|
| 1. Dust cap | 4. Air-cleaner body |
| 2. Latch (dust cap) | 5. Dust valve |
| 3. Air-filter element | |

- Check the air-cleaner body for damage that could cause an air leak (Figure 67).

Note: Replace the dust cap and air-cleaner body if either is damaged.

- Squeeze the dust valve to clear it of dirt, dust, and debris (Figure 67).
- Loosen the 2 latches that secure the dust cap to the air-cleaner body.
- Check the air-filter element for excessive accumulation of dust, dirt, and debris (Figure 67).

Note: Do not clean the air-filter element if it is dirty; replace the air-filter element if it is dirty.

8. Install the dust cap onto the air-cleaner body and secure the cap with the 2 latches (Figure 67).

Note: Ensure that the dust valve aligns between the 5 to 7 o'clock position when viewed from the end.

9. Lower the passenger seat.

Replacing the Air-Filter Element

Service Interval: Every 100 hours—Replace the air-filter element. Replace the air-filter element more often in dusty, dirty conditions.

1. If you are installing a new filter, inspect the new air-filter element for shipping damage, including the sealing end of the filter.

Important: Do not install a damaged filter.

2. Clean the dust cap and air-cleaner body (Figure 67).
3. Lift the coolant-overflow tank up and off the tank-support bracket (Figure 68).

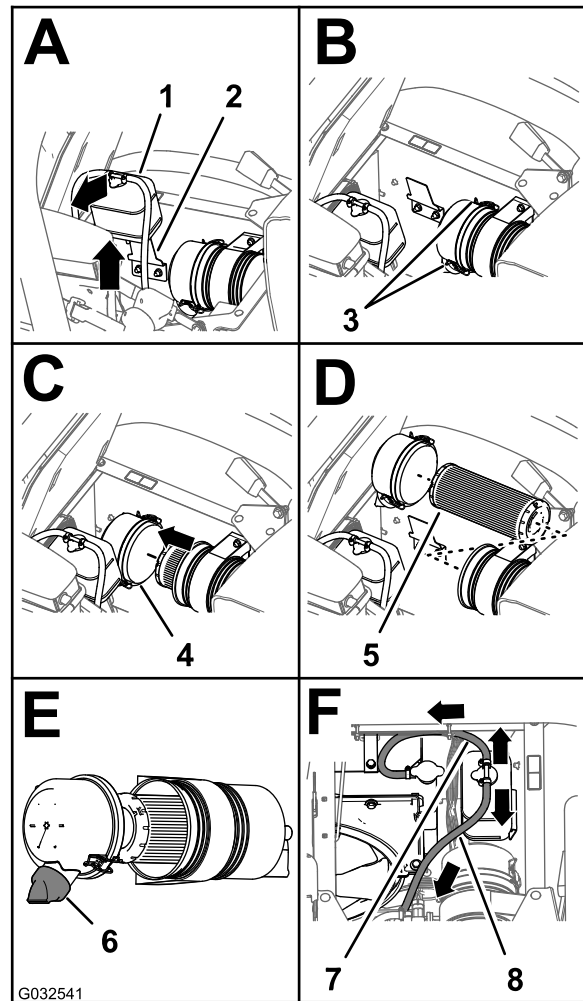

G032541

g032541

Figure 68

- | | |
|--------------------------|---|
| 1. Coolant-overflow tank | 5. Air-filter element |
| 2. Tank-support bracket | 6. Dust valve (5 to 7 o'clock position) |
| 3. Latch (dust cap) | 7. Pressure-relief hose |
| 4. Dust cap | 8. Tank-vent hose |

4. Loosen the 2 latches that secure the dust cap to the air-cleaner body (Figure 68).

5. Gently slide the old filter element out of the air-cleaner body to reduce the amount of dust dislodged.

Note: Avoid knocking the filter element against the air-cleaner body.

6. Clean the inside of the dust cap, air-cleaner body, and dust valve with a damp rag (Figure 67 and Figure 68).

7. Insert the air-filter element into the air-cleaner body (Figure 68).

Note: Ensure that the filter is seated in the air-cleaner body properly by applying pressure to the outer rim of the filter element when you install it. Do not press on the flexible center part of the filter.

8. Install the cover onto the air-cleaner body and secure the cover with the 2 latches (Figure 68).

Note: Ensure that the dust valve is aligned between the 5 to 7 o'clock position when viewed from the end (Figure 68).

9. Align the coolant-overflow tank to the tank-support bracket and seat the tank firmly (Figure 68).

Important: Ensure that the pressure-relief hose is routed forward and down, and the tank-vent hose is routed rearward as shown in Figure 68.

10. Lower the passenger seat.

Servicing the Engine Oil

Service Interval: After the first 50 hours—Change the engine oil and oil filter.

Every 150 hours—Change the engine oil (including synthetic oil) and oil filter. (more often when operating under heavy load or in high temperatures).

Every 400 hours/Yearly (whichever comes first)—Complete all yearly maintenance procedures specified in the **engine owner's manual**.

Crankcase oil capacity: 4.6 L (4.9 US qt) with the filter.

Engine oil specification:

- **Oil type**—API service CH-4, CI-4 or higher.
- **Preferred oil viscosity**—SAE 15W-40 (above 0 degrees F)
- **Alternate oil viscosity**—SAE 10W-30 or 5W-30 (all temperatures)

Toro Premium Engine Oil is available from your distributor in either 15W-40 or 10W-30 viscosity. Refer to the *Parts Catalog* for part numbers.

Checking the Engine Oil

Service Interval: Before each use or daily Check the engine-oil level before you start the engine for the first time.

Note: The best time to check the engine oil is when the engine is cool, before it has been started for the day. If the engine was operated, allow the oil to drain back down to the sump for at least 10 minutes before checking.

The engine is shipped with oil in the crankcase; however, the level of oil must be checked before you first start the engine and after you have run it.

1. Position the machine on a level surface.
2. Remove the dipstick, located under the passenger seat, and wipe it with a clean rag (Figure 69).

Note: Insert the dipstick into the tube and make sure it is seated fully. Remove the dipstick and check the oil level.

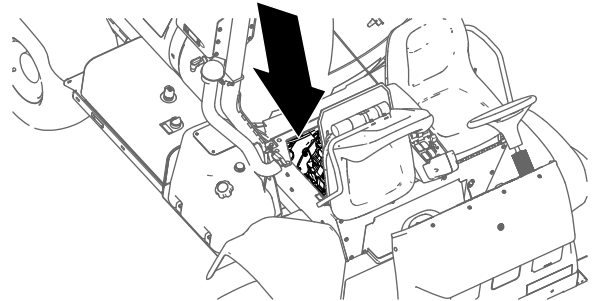

g195188

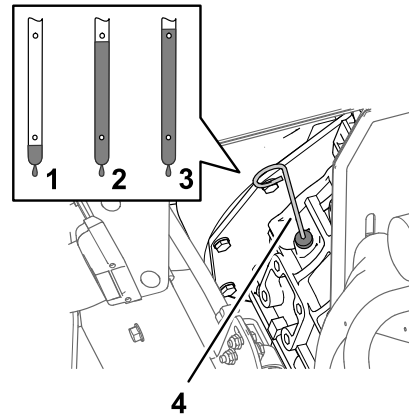

g195187

Figure 69

- | | |
|---------|-------------|
| 1. Low | 3. High |
| 2. Full | 4. Dipstick |

3. If the oil level is low, remove the filler cap from the valve cover and pour oil into the filler neck until the oil level is up to the Full mark on the dipstick (Figure 70).

Note: Add the oil slowly and check the level often during this process. Do not overfill.

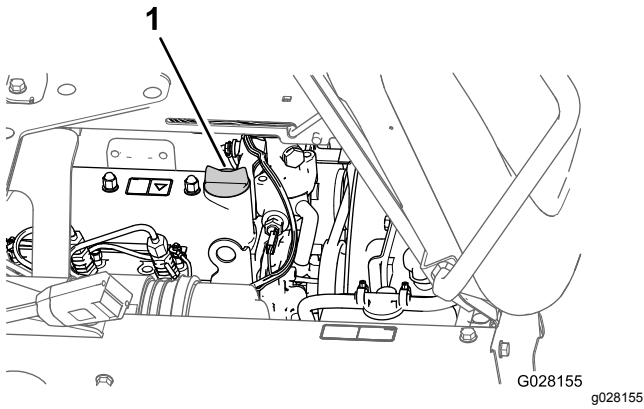

Figure 70

1. Oil-filler cap

4. Install the oil-filler cap.
5. Install the dipstick firmly in place.

Changing the Engine Oil Filter

1. Remove the forward heat shield; refer to [Removing the Forward Heat Shield \(page 48\)](#).
2. Raise the seats.

CAUTION

Components under the seat will be hot if the sprayer has been running. If you touch hot components, you may be burned.

Allow the sprayer to cool before performing maintenance or touching components under the hood.

3. Align a drain pan under the engine oil filter ([Figure 71](#)).

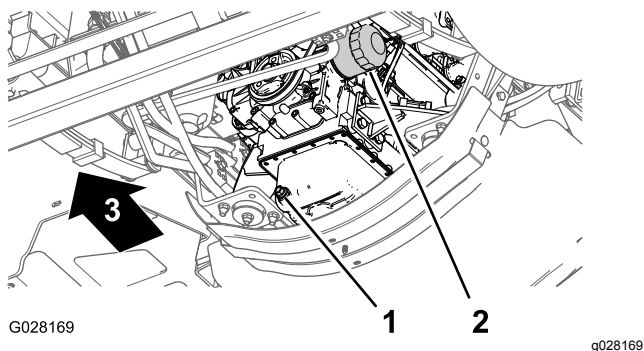

Figure 71

1. Drain plug
2. Engine oil filter

4. Remove the old oil filter ([Figure 71](#)).

Note: Dispose of the used oil filter at a certified recycling center.

5. Wipe clean the surface of the oil filter adapter of the engine with a rag.
6. Fill the oil filter with the specified oil.
Note: Allow the filter element to saturate with oil.
7. Apply a thin coat of the specified oil to the rubber gasket on the replacement oil filter.
8. Install the oil filter to the filter adapter and turn the oil filter clockwise until the rubber gasket contacts the filter adapter, then tighten the filter an additional 1/2 turn ([Figure 71](#)).
Note: Do not overtighten the oil filter.
9. Wipe clean any residual oil.

Changing the Engine Oil

1. Align a drain pan under the drain plug ([Figure 71](#)).
2. Remove the drain plug and allow the oil to drain completely ([Figure 71](#)).

Note: Check the drain-plug seal for wear and damage; replace the seal if it is worn or damaged.

Note: Dispose of the used oil at a certified recycling center.

3. Install the drain plug into the drain port of the engine-oil pan and tighten the plug to 33 to 37 N·m (24 to 27 ft-lb).
4. Tilt the passenger seat forward and align the prop rod into the detent in the prop-rod-guide slot.
5. Remove the oil-filler cap from the filler neck of the valve cover of the engine and slowly pour approximately 80% of the specified amount of oil into the filler neck ([Figure 72](#)).

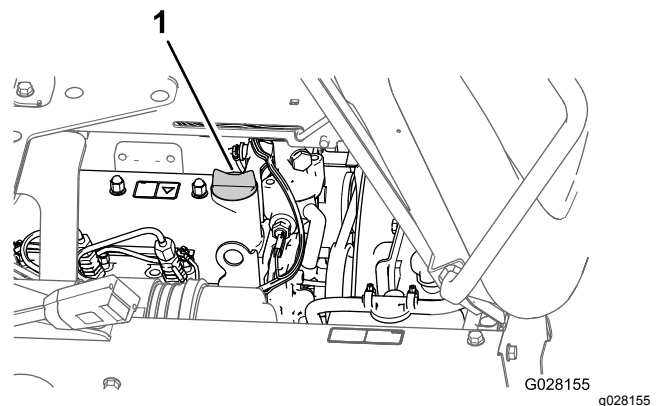

Figure 72

1. Oil-filler cap

- Remove the dipstick and check the oil level in the engine ([Figure 73](#)).

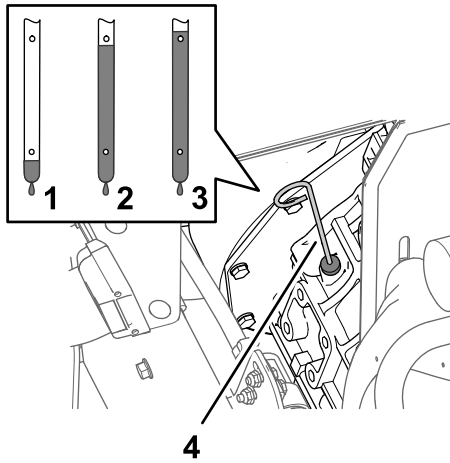

Figure 73

- | | |
|---------|-------------|
| 1. Low | 3. High |
| 2. Full | 4. Dipstick |

- Slowly add additional specified oil to bring the oil level to the Full mark on the dipstick ([Figure 73](#)).

Important: Overfilling the engine with oil may cause damage to the engine.

- Install the oil-filler cap into the filler neck ([Figure 72](#)).
- Install the forward heat shield; refer to [Installing the Forward Heat Shield](#) (page 49).

Fuel System Maintenance

⚠ DANGER

Under certain conditions, diesel fuel and fuel vapors are highly flammable and explosive. A fire or explosion from fuel can burn you and others and can cause property damage.

- Use a funnel and fill the tank outdoors, in an open area, when the engine is off and is cold. Wipe up any fuel that spills.
- Do not fill the fuel tank completely full. Add fuel to the fuel tank until the level is 25 mm (1 inch) below the bottom of the filler neck. This empty space in the tank allows the fuel to expand.
- Never smoke when handling fuel, and stay away from an open flame or where fuel fumes may be ignited by a spark.
- Store fuel in a clean, safety-approved fuel container and keep the cap in place.

Checking the Fuel Line and Connections

Service Interval: After the first 50 hours

Every 400 hours/Yearly (whichever comes first)

Inspect the lines and fittings for deterioration, damage, or loose connections.

Bleeding the Fuel System

Note: Ensure that the fuel tank is at least half full.

- Engage the parking brake, shut off the spray pump, shut off the engine, and remove the key.
- Remove the forward heat shield; refer to [Removing the Forward Heat Shield](#) (page 48).
- Tilt the passenger seat forward and align the prop rod into the detent in the prop-rod-guide slot.
- Align a drain pan under the fuel filter; refer to [Figure 76](#) in [Replacing the Water-Separator Filter](#) (page 59).
- Loosen the vent plug at the top of the fuel/water separator ([Figure 74](#)).

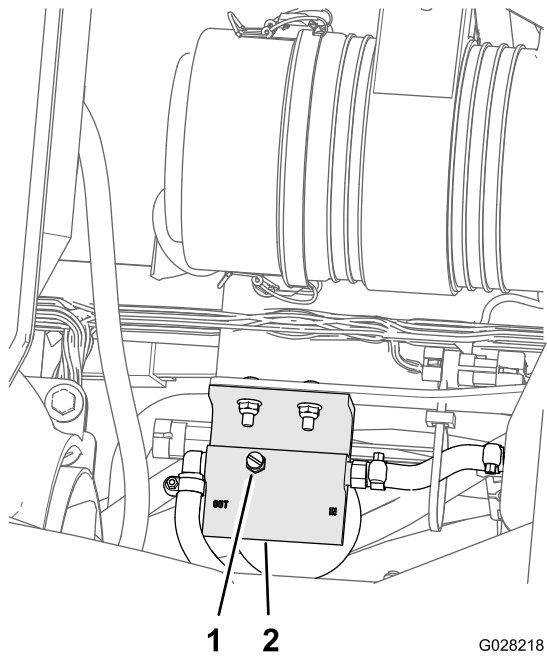

1 2

G028218

g028218

Figure 74

1. Vent plug
2. Top of the fuel/water separator

6. Turn the key in the starter switch to the ON position.

Note: The electric fuel pump will begin forcing air out around the vent plug. Leave the key in the ON position until a solid stream of fuel flows out around the vent plug.

7. Tighten the vent plug and turn the starter switch to the OFF position (Figure 74).
8. Align the drain pan under the fuel-injection pump portion of the engine (Figure 75).

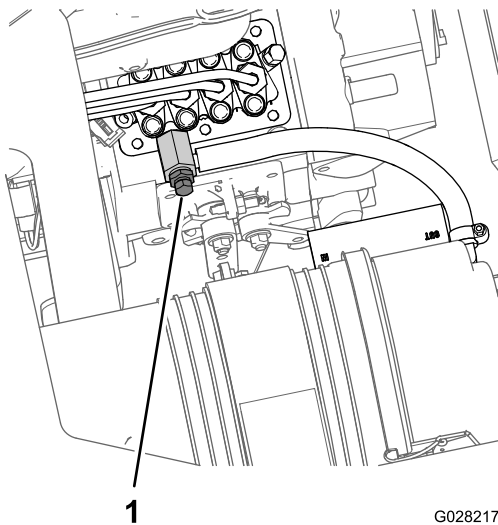

1

G028217

g028217

Figure 75

1. Bleed screw (fuel-injection pump)

9. Open the air-bleed screw at the fuel-injection pump (Figure 75).
10. Turn key in starter switch to the ON position.

Note: The electric fuel pump will begin operation, forcing air out around the air-bleed screw at the fuel-injection pump.
11. Leave the key in the ON position until a solid stream of fuel flows out around the bleed screw (Figure 75).
12. Tighten the bleed screw (Figure 75) and turn the key to the OFF position.

Note: Normally, the engine should start after you bleed the fuel system. However, if the engine does not start, there may be air trapped between the injection pump and the injectors; refer to [Bleeding Air from the Injectors](#) (page 58).

Bleeding Air from the Injectors

You should perform this procedure only after you have purged the air in the fuel system and the engine does not start; refer to [Bleeding the Fuel System](#) (page 57).

1. Align a drain pan under the right side of the engine.
2. Loosen the tube nut at the No. 1 fuel-injector nozzle and holder assembly.
3. Move the throttle to the FAST position.
4. Turn the key in the key switch to the START position and watch the fuel flow around the connector.
5. Turn the key to the OFF position when you observe a solid flow of fuel.
6. Tighten the tube nut.
7. Clean residual fuel from the area around the fuel injector.
8. Repeat steps 2 through 7 for the remaining fuel-injector nozzles.
9. Install the forward heat shield; refer to [Installing the Forward Heat Shield](#) (page 49).

Servicing the Fuel Filters

Replacing the Water-Separator Filter

Service Interval: Every 400 hours

1. Remove the forward heat shield; refer to [Removing the Forward Heat Shield \(page 48\)](#).
2. Place a drain pan under the water-separator filter ([Figure 76](#)).

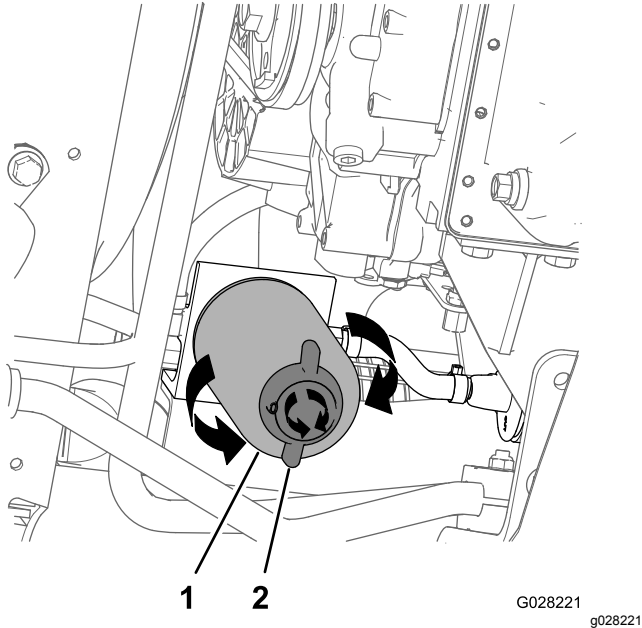

Figure 76

1. Water-separator filter
2. Drain valve

3. Rotate the drain valve at the bottom of the water-separator filter counterclockwise ([Figure 76](#)).

Note: Allow the fuel to drain from the filter completely, then close the valve.

4. Clean the area around the water-separator filter and filter-adapter mount ([Figure 76](#)).
 5. Remove the water-separator filter ([Figure 76](#)).
- Note:** Dispose of the used fuel and filter canister at a certified recycling center.
6. Clean the mounting surface of the filter adapter.
 7. Lubricate the gasket on the water-separator filter with clean engine oil.

8. Install the filter by hand until the gasket contacts the mounting surface, then rotate the filter an additional 1/2 turn.
9. Ensure that the drain valve at the bottom of the water-separator filter is rotated clockwise tightly ([Figure 76](#)).

Replacing the In-Tank Fuel Filter

Service Interval: Every 400 hours

Removing the In-Tank Fuel Filter

Note: The fuel filter is a part of the standpipe assembly.

1. Engage the parking brake, shut off the spray pump, shut off the engine, and remove the key.
2. At the fuel tank, remove the 4 screws (#10 x 3/4 inch) that secure the cover to the top of the fuel tank, and remove the cover ([Figure 77A](#)).

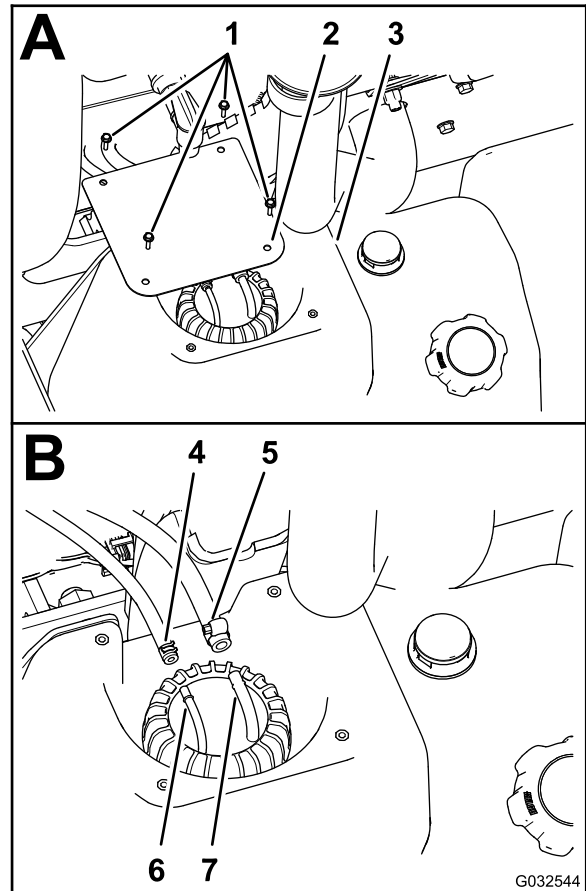

Figure 77

1. Screws (#10 x 3/4 inch)
2. Cover
3. Fuel tank
4. Clamp—6.4 mm (1/4 inch) fuel hose
5. Clamp—8 mm (5/16 inch) fuel hose
6. Hose fitting—6.4 mm (1/4 inch)
7. Hose fitting—8 mm (5/16 inch)

3. Loosen the clamps that secure the 2 fuel hoses to the 2 hose fittings at the top of the standpipe assembly ([Figure 77B](#)).
4. Disconnect the 2 hoses from the hose fittings, and allow any fuel in the hoses to drain into an approved fuel container ([Figure 77B](#)).

- Rotate the fuel-standpipe/sender cap counterclockwise, then remove the cap (Figure 78).

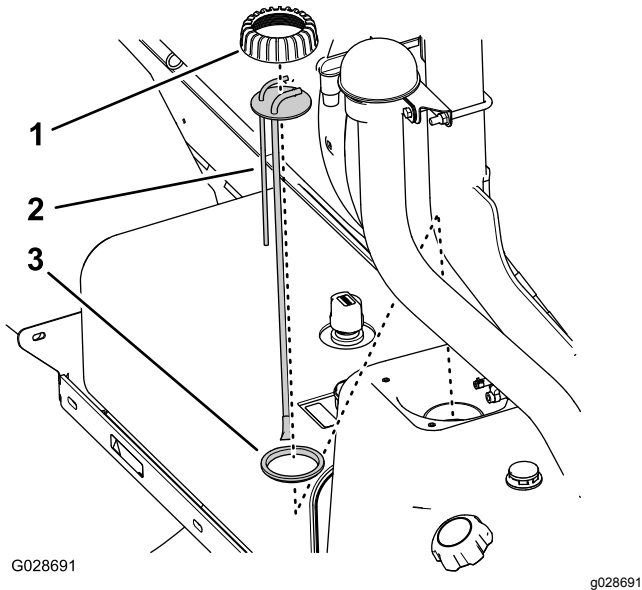

Figure 78

- | | |
|-----------------------------------|---------|
| 1. Fuel-standpipe/sender cap | 3. Seal |
| 2. Fuel-standpipe/sender assembly | |

- Lift the fuel-standpipe/sender assembly from the fuel tank (Figure 78).

Note: Discard the old standpipe assembly.

Installing the In-Tank Fuel Filter

Note: Obtain the new stand pipe assembly from your local Authorized Toro Dealer. You may need a new seal to secure the elbow fitting and standpipe assembly to the top of the fuel tank.

- Assemble the standpipe cap over the stand pipe and the standpipe to the seal (Figure 78).
- Align the cap, standpipe, and seal to the tank, and carefully insert the new stand-pipe assembly into the fuel tank (Figure 78).

Note: Align the hose fittings toward the center line of the machine.

- Thread the cap onto the neck of the fuel tank and tighten the cap hand tight (Figure 78).
- Assemble the 6.4 mm (1/4 inch) fuel hose onto the 6.4 mm (1/4 inch) hose fitting, and secure the hose to the fitting with the hose clamp (Figure 77B).
- Assemble the 8 mm (5/16 inch) fuel hose onto the 8 mm (5/16 inch) hose fitting, and secure the hose to the fitting with the hose clamp (Figure 77B).

- Assemble the cover to the tank (Figure 77A) with the 4 screws (#10 x 3/4 inch) that you removed in step 2 of [Removing the In-Tank Fuel Filter](#) (page 59).
- Torque the screws to 113 N·cm (10 in·lb).

Draining the Fuel Tank

Service Interval: Every 400 hours/Yearly (whichever comes first)

Drain and clean the fuel tank if the fuel system becomes contaminated or if you plan to store the machine for an extended period. When cleaning the fuel tank, use fresh, clean fuel to flush out the tank.

- Transfer the fuel from the tank into an approved fuel container using a siphon pump, or remove the tank from the machine and pour the fuel out of the tank-fill spout into the fuel container.

Note: If you remove the fuel tank, you will need to remove the fuel supply and return hoses from the standpipe assembly before removing the tank; refer to steps 1 through 4 in [Removing the In-Tank Fuel Filter](#) (page 59).

- Replace the fuel filters; refer to the [Replacing the Water-Separator Filter](#) (page 59).
- Flush the tank with fresh, clean fuel, if necessary.
- Install the tank if you removed it; refer to step 1 through 5 in [Installing the In-Tank Fuel Filter](#) (page 60).
- Fill the tank with fresh, clean fuel.

Electrical System Maintenance

Replacing the Fuses

The fuse block for the electrical system is located beneath the operator's seat (Figure 79).

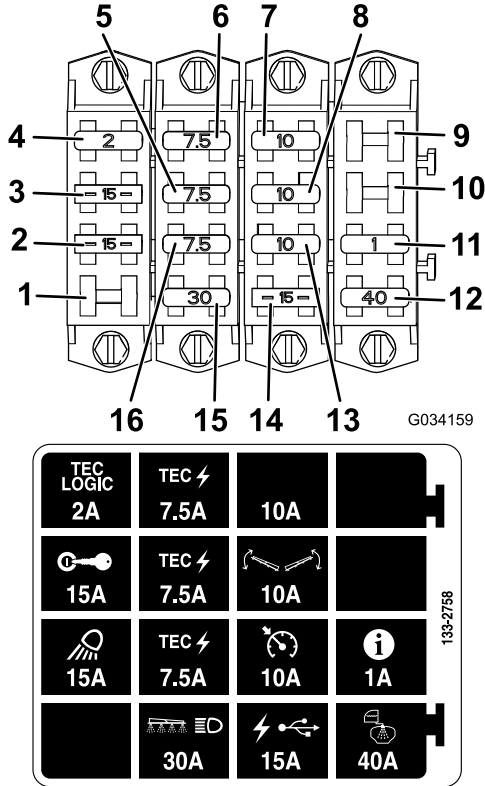

Figure 79

- | | |
|--------------------|------------------------|
| 1. Open slot | 9. Open slot |
| 2. Work light | 10. Open slot |
| 3. Ignition | 11. InfoCenter |
| 4. Tec Logic | 12. Tank spray |
| 5. Tec power | 13. Cruise control |
| 6. Tec power | 14. USB power |
| 7. Extra fuse slot | 15. Boom and headlight |
| 8. Boom control | 16. Tec power |

Servicing the Battery

WARNING

CALIFORNIA Proposition 65 Warning

Battery posts, terminals, and related accessories contain lead and lead compounds, chemicals known to the State of California to cause cancer and reproductive harm. Wash hands after handling.

Always keep the battery clean and fully charged. Use a paper towel to clean the battery and battery box. If the battery terminals are corroded, clean them with a solution of 4 parts water and 1 part baking soda. Apply a light coating of grease to the battery terminals to prevent corrosion.

Voltage: 12 V with 690 A (cold cranking) at 0°F (-18°C).

Removing the Battery

1. Position the sprayer on a level surface, engage the parking brake, shut off the spray pump, shut off the engine, and remove the key.
2. Remove the battery cover and disconnect the negative (black) ground cable from the battery post (Figure 80).

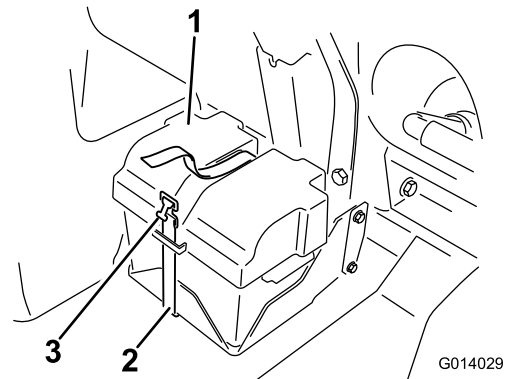

Figure 80

- | | |
|------------------|-----------|
| 1. Battery cover | 3. Buckle |
| 2. Strap | |

⚠ WARNING

Incorrect battery cable routing could damage the sprayer and cables causing sparks. Sparks can cause the battery gasses to explode, resulting in personal injury.

- Always *disconnect* the negative (black) battery cable before disconnecting the positive (red) cable.
- Always *connect* the positive (red) battery cable before reconnecting the negative (black) cable.

⚠ WARNING

Battery terminals or metal tools could short against metal sprayer components causing sparks. Sparks can cause the battery gasses to explode, resulting in personal injury.

- When removing or installing the battery, do not allow the battery terminals to touch any metal parts of the sprayer.
 - Do not allow metal tools to short between the battery terminals and metal parts of the sprayer.
 - Always keep the battery strap in place to protect and secure the battery.
3. Disconnect the positive (red) cable from the battery post.
 4. Remove the battery.

Installing the Battery

1. Set the battery on the battery box so that the battery posts are away from the sprayer.
2. Connect the positive (red) cable to the positive (+) battery post and the negative (black) cable to the negative (-) battery post using the bolts and nuts.
3. Slide the insulator boot over the positive battery post.
4. Install the battery cover and secure it with the strap that you removed previously (Figure 80).

Important: Always keep the battery retainer in place to protect and secure the battery.

Charging the Battery

Important: Always keep the battery fully charged. This is especially important to prevent battery damage when the temperature is below 32°F (0°C).

1. Remove the battery from the chassis; refer to [Removing the Battery \(page 61\)](#).
2. Connect a 3 to 4 A battery charger to the battery posts and charge the battery at a rate of 3 to 4 A for 4 to 8 hours (12 V).

Important: Do not overcharge the battery.

3. Install the battery in the chassis; refer to [Installing the Battery \(page 62\)](#).

Storing the Battery

If you are storing the machine for more than 30 days, remove the battery and charge it fully. Either store it on a shelf or on the machine. Disconnect the battery cables if the battery is stored on the machine. Store the battery in a cool atmosphere to avoid quick deterioration of the charge in the battery. To prevent the battery from freezing, ensure that it is fully charged.

Drive System Maintenance

Inspecting the Wheels/Tires

Service Interval: After the first 8 hours—Torque the wheel-lug nuts.

Every 100 hours—Torque the wheel-lug nuts.

Every 100 hours—Inspect the condition and wear of the tires.

Torque the lug nuts at the front wheels to 75 to 102 N·m (55 to 75 ft-lb) and the lug nuts at the rear wheels to 95 to 122 N·m (75 to 90 ft-lb).

Operating accidents such as hitting curbs can damage a tire or rim and also disrupt wheel alignment, so inspect tire condition after an accident.

Changing the Planetary-Gearbox Fluid

Service Interval: After the first 8 hours

Every 400 hours

Use high quality, SAE 85W-140 weight gear lube.

1. Position the sprayer on a level surface with the rear wheels positioned as shown in [Figure 81](#).

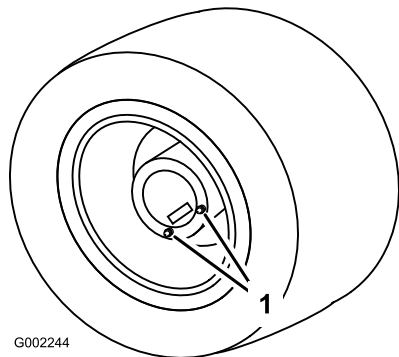

Figure 81

1. Drain plugs

2. Engage the parking brake, shut off the spray pump, shut off the engine, and remove the key.
3. Align a drain pan under the drain plugs and remove them from the hub ([Figure 81](#)).
4. Align a pan under the inner drain plug at the brake housing and remove the plug ([Figure 82](#)).

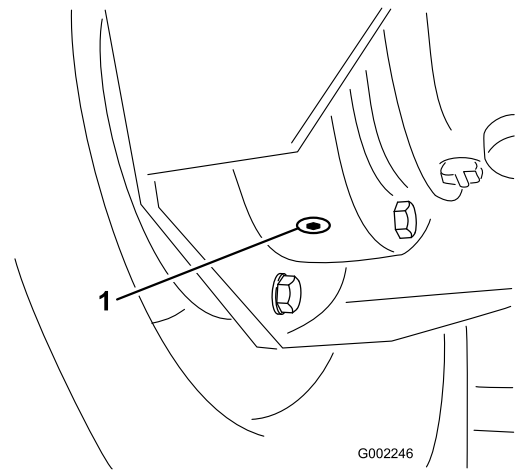

Figure 82

1. Inner drain plug

5. Move the vehicle slowly until the wheel is positioned as shown in [Figure 83](#).

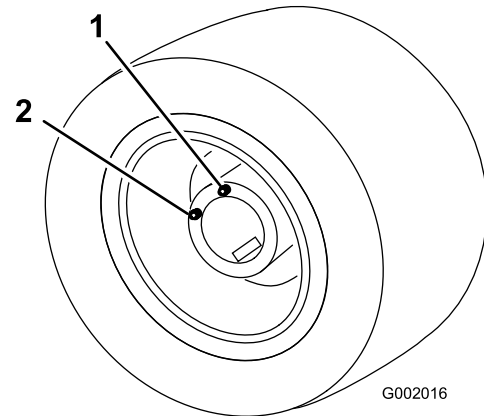

Figure 83

1. Upper hole—add fluid here
2. Lower hole here

6. Engage the parking brake, shut off the engine, and remove the key.
7. Pour SAE 85W-140 weight gear lube into the upper hole until it begins to come out of the lower hole.
8. Install and tighten all drain plugs.
9. Repeat steps [3](#) through [9](#) for the other rear wheel.
10. Dispose of the used oil at a certified recycling center.

Adjusting the Front Wheel Toe-in

Service Interval: Every 200 hours/Yearly (whichever comes first)

You should measure 0 to 3 mm (0 to 1/8 inch) between the front centerline of the tires and the back centerline of the tires.

1. Check and fill all tires; refer to [Checking the Tire Air Pressure \(page 26\)](#).
2. Measure the distance between both of the front tires at the axle height at both the front and rear of the front tires ([Figure 84](#)).

Note: The distance between the front of the tires should be 0 to 3 mm (0 to 1/8 inch) less than the distance between the back side of the front tires.

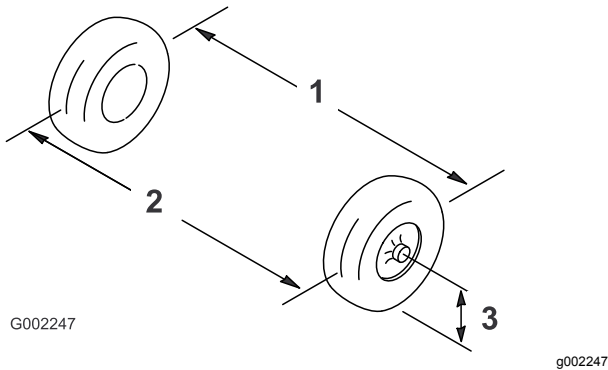

Figure 84

1. Tire center line—back
2. Tire center line—front
3. Axle center line

3. If the measurement does not fall within the specified range, loosen the jam nuts at both ends of the tie rod ([Figure 85](#)).

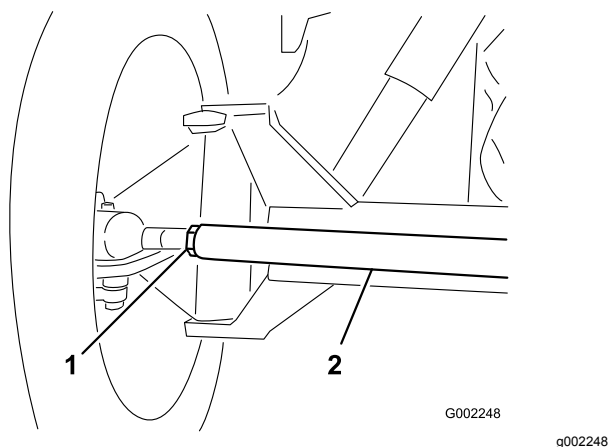

Figure 85

1. Jam nut
2. Tie rod

4. Rotate the tie rod to move the front of the tire inward or outward.
5. Tighten the tie rod jam nuts when the adjustment is correct.
6. Ensure that the steering wheel rotates an equal amount in both directions.

Cooling System Maintenance

Servicing the Cooling System

Service Interval: Every 100 hours—Check the cooling-system hoses for wear and damage.

Cooling system capacity: 5.5 L (5.8 US qt)

Coolant type: a solution of 50% water and 50% permanent ethylene glycol antifreeze

Important: Do not add coolant to an overheated engine until the engine has fully cooled. Adding coolant to an overheated engine may crack the engine block.

Check the engine-coolant concentration as directed by the coolant manufacturer.

Checking the Coolant Level

Service Interval: Before each use or daily Check the level of coolant in the radiator and the expansion tank at the beginning of each day before starting the engine.

⚠ CAUTION

If the engine has been running, the coolant may be hot and pressurized. If you open the radiator cap when the coolant is hot, it could spray out and severely burn you or bystanders.

Allow the engine to cool for at least 15 minutes before opening the radiator cap.

1. Position the sprayer on a level surface.
2. Engage the parking brake, shut off the spray pump, shut off the engine, and remove the key.
3. Carefully remove the radiator cap and the expansion-tank cap (Figure 86).

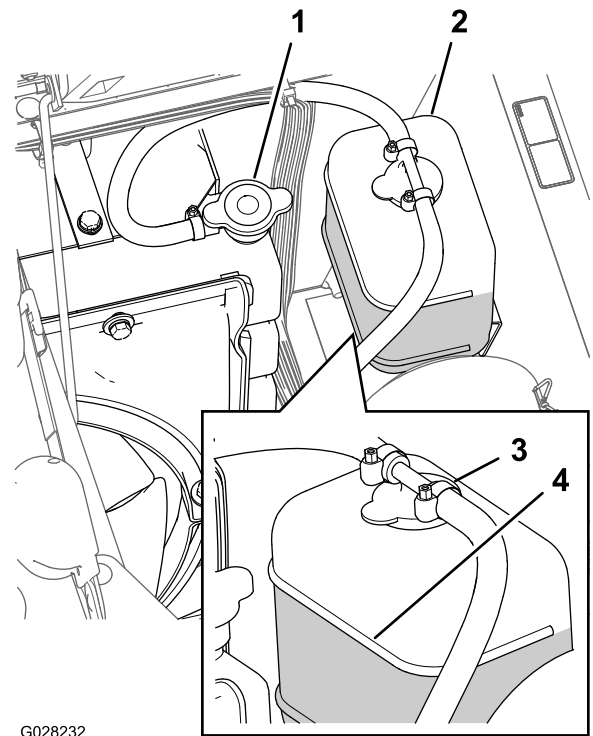

G028232

g028232

Figure 86

- | | |
|-------------------|-----------------------|
| 1. Radiator cap | 3. Expansion-tank cap |
| 2. Expansion tank | 4. Full-line mark |

4. Check the coolant level in the radiator and in the expansion tank.

Note: The radiator should be filled to the top of the filler neck and the expansion tank filled to the Full mark on the tank (Figure 86).

5. If the coolant level is low, remove the expansion-tank cap and the radiator cap, and fill the expansion tank to the Full mark and the radiator to the top of the filler neck (Figure 86).

Important: Do not overfill the expansion tank.

Important: Do not use water only or an alcohol/methanol-based coolant.

6. Install the radiator cap and the expansion-tank cap (Figure 86).

Changing the Cooling-System Fluid

Service Interval: Every 400 hours/Yearly (whichever comes first)—Check the coolant (as directed by the manufacturer) and change if necessary.

Owner provided equipment: a handheld coolant thermometer

1. Position the sprayer on a level surface, engage the parking brake, shut off the spray pump, shut off the engine, and remove the key.
2. Wait until the engine is cool, then remove the radiator cap (Figure 86).
3. Place a large drain pan under the radiator.
4. Open the drain valve and drain the coolant into the pan (Figure 87).

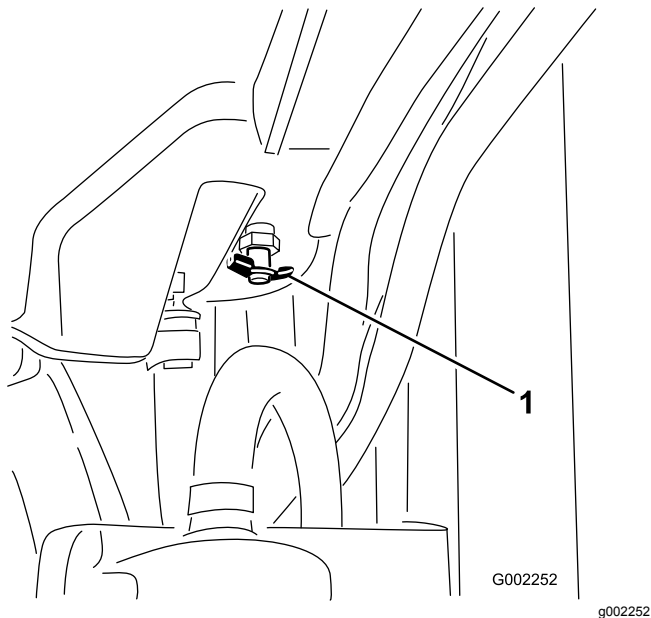

Figure 87

1. Drain valve

-
5. Close the drain valve (Figure 87).
 6. Remove the radiator cap (Figure 86).
 7. Slowly fill the radiator with coolant to approximately 2.5 cm (1 inch) below the sealing surface of the cap.

Note: Use enough coolant to fill the engine and the system lines. This allows the coolant to expand without it overflowing while the engine is warming up.

8. Start the engine with the cap loose on the radiator (Figure 86).
9. Allow the engine to warm up until the thermostat opens.

Note: The engine thermostat should open when the hand-held thermometer indicates the coolant temperature is between 79° to 88°C (175° to 190°F).

10. Once the coolant has warmed up, top off the coolant level to the sealing surface of the cap and tighten the cap (Figure 86).
11. Open the expansion-tank cap and fill the tank with coolant to the Cold level (Figure 86).
12. Check the coolant levels after several engine startup and shut-down cycles.

Note: Add coolant to the radiator and expansion tank as needed.

Brake Maintenance

Adjusting the Brakes

If the brake pedal travels more than 2.5 cm (1 inch) before you feel resistance, adjust the brakes as follows:

1. Position the sprayer on a level surface, shut off the spray pump, shut off the engine, and remove the key.
2. Engage the parking brake.
3. Put blocks under the wheels to prevent the machine from rolling.
4. Release the parking brake.
5. Loosen the front jam nuts on the brake cables under the front end of the sprayer (Figure 88).

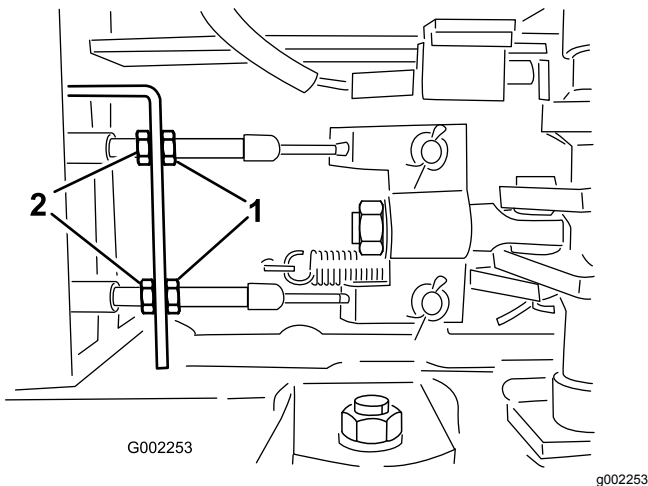

Figure 88

1. Front jam nuts
2. Rear jam nuts

6. Tighten the rear jam nuts equally until the brake pedal moves between 1 to 2 cm (1/2 to 1 inch) before you feel resistance (Figure 88).

Important: Ensure that you tighten both rear nuts equally so that the threaded ends of the brake cables in front of the front nuts are the same length.

7. Tighten the front jam nuts.

Belt Maintenance

Servicing the Alternator Belt

Service Interval: After the first 8 hours

Every 100 hours

Check the condition and tension of the alternator/cooling fan belt. Replace the belt as necessary.

1. Position the sprayer on a level surface, engage the parking brake, shut off the spray pump, shut off the engine, and remove the key.
2. Check the alternator-belt tension by depressing the belt midway between the alternator and the crankshaft pulleys with 10 kg (22 lb) of force.

Note: The belt should deflect 10 to 12 mm (0.39 to 0.47 inches). If the belt deflection is too much, go to step 3. If the belt tension is correct, you may skip the remainder of this procedure and resume operating the sprayer.

3. Loosen the bolt at the pivot point of the alternator; loosen the bolt that secures the alternator to the slotted brace (Figure 89).

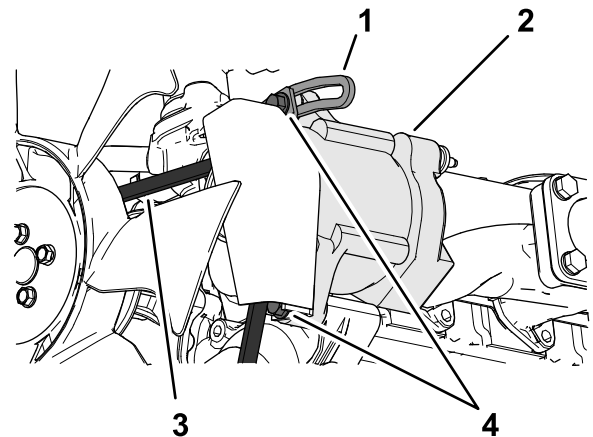

Figure 89

1. Brace
2. Alternator
3. Alternator belt
4. Bolts

4. Insert a pry bar between the alternator and the engine and carefully pry on the alternator outward.
5. When you achieve the proper tension, tighten the alternator and the bolts to secure the adjustment.
6. Tighten the locknut to secure the adjustment.

Hydraulic System Maintenance

Checking the Hydraulic Fluid

Service Interval: Before each use or daily Check the level of the hydraulic fluid before the engine is first started and daily thereafter.

Hydraulic fluid specifications: Toro Premium All Season Hydraulic Fluid

Note: Available in 19 L (5 US gallons) pails or 208 L (55 US gallons) drums. See the parts catalog or your Authorized Toro Distributor for part numbers.

Alternate hydraulic fluids: If the Toro fluid is not available, other fluids may be used provided they meet all the following material properties and industry specifications. We do not recommend the use of synthetic fluid. Consult with your lubricant distributor to identify a satisfactory product.

Note: Toro will not assume responsibility for damage caused by improper substitutions, so use only products from reputable manufacturers who will stand behind their recommendation.

High Viscosity Index/Low Pour Point Anti-wear Hydraulic Fluid, ISO VG 46

Material Properties:

Viscosity, ASTM D445	cSt @ 40°C 44 to 50 cSt @ 100°C 7.9 to 8.5
Viscosity Index ASTM D2270	140 to 160
Pour Point, ASTM D97	-34°F to -49°F

Industry Specifications:

Vickers I-286-S (Quality Level), Vickers M-2950-S (Quality Level), Denison HF-0

Important: The ISO VG 46 Multigrade fluid has been found to offer optimal performance in a wide range of temperature conditions. For operation in consistently high ambient temperatures, 18°C (65°F) to 49°C (120°F), ISO VG 68 hydraulic fluid may offer improved performance.

Premium Biodegradable Hydraulic Fluid-Mobil EAL EnviroSyn 46H

Important: Mobil EAL EnviroSyn 46H is the only synthetic biodegradable fluid approved by Toro. This fluid is compatible with the elastomers used in Toro hydraulic systems and is suitable for a wide-range of temperature conditions. This fluid is compatible with conventional mineral oils, but for maximum biodegradability and performance the hydraulic system should be thoroughly flushed of

conventional fluid. The oil is available in 19 L (5 US gallons) pails or 208 L (55 US gallons) from your Mobil Distributor.

1. Position the sprayer on a level surface, engage the parking brake, shut off the spray pump, shut off the engine, and remove the key.
2. Clean the area around the hydraulic-fluid-tank dipstick cap and remove it (Figure 90).

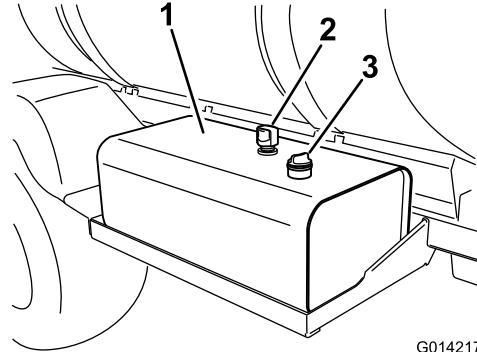

Figure 90

1. Hydraulic-fluid tank
2. Vent
3. Dipstick cap

Important: Be very careful not to get dirt or other contaminants into the opening when checking the fluid.

3. Wipe the dipstick clean with a cloth and replace it completely in the tank.
4. Remove the dipstick from the filler neck and check the fluid level (Figure 91).

Note: The fluid level should be within the safe-operating range on the dipstick.

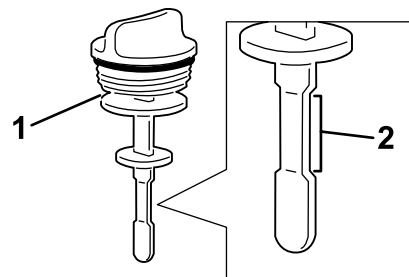

Figure 91

1. Dipstick
2. Safe-operating range

5. If the fluid is low, fill the tank with the specified hydraulic fluid or equivalent to raise the level to the upper mark.
6. Install the dipstick cap into the tank and secure.

Servicing the Hydraulic System

If the fluid becomes contaminated, contact an Authorized Toro Distributor to have the system flushed.

Note: Contaminated fluid looks milky or black when compared to clean fluid.

Replacing the Hydraulic-Fluid Filters

Service Interval: After the first 5 hours

Every 400 hours/Yearly (whichever comes first)

Use the Toro replacement filter (See your *Parts Manual* for the correct part number.)

Important: Use of any other filter may void the warranty on some components.

⚠ WARNING

Hot hydraulic fluid can cause severe burns.

Allow the hydraulic fluid to cool before performing any maintenance to the hydraulic system.

1. Position the sprayer on a level surface, engage the parking brake, shut off the spray pump, shut off the engine, and remove the key.
2. Locate the 2 hydraulic filters on the machine (Figure 92 and Figure 93).

Note: 1 filter is below the hydraulic-fluid tank and the other filter is located at the rear of the machine on the frame.

- Forward filter—below the hydraulic tank.

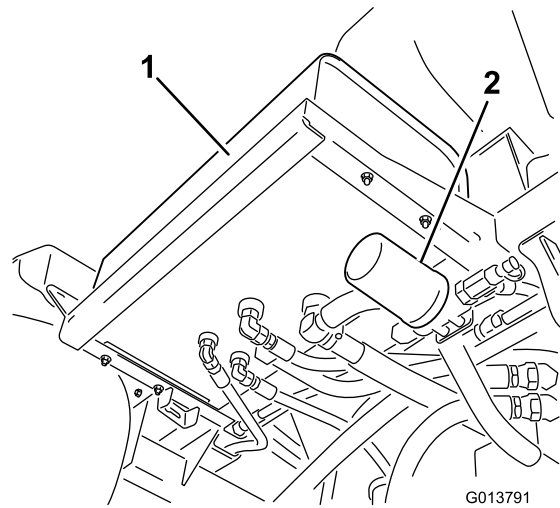

Figure 92

1. Hydraulic tank
2. Forward filter

- Rear filter—located on the machine frame.

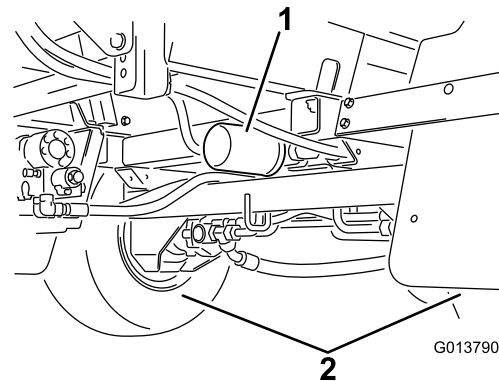

Figure 93

1. Rear filter
2. Rear wheels

3. Clean the area around the filter-mounting area.
4. Place a drain pan under the filter.
5. Remove the filter.
6. Lubricate the new filter gasket with clean hydraulic fluid.
7. Wipe clean the filter-mounting area with a rag.
8. Thread the filter on until the gasket contacts the mounting plate, then tighten the filter an additional 1/2 turn.
9. Start the engine, set the throttle at fast idle, and let the engine run 3 to 5 minutes to purge air from the hydraulic system.
10. Shut off the engine, check the hydraulic-fluid level, and check for leaks.
11. Dispose of the used filter at a certified recycling center.

Changing the Hydraulic Fluid

Service Interval: Every 400 hours/Yearly (whichever comes first)

Hydraulic-fluid capacity: 56 L (15 US gallons) of the specified hydraulic fluid or equivalent; refer to [Checking the Hydraulic Fluid \(page 68\)](#).

Important: Using any other fluid may void the warranty on some components.

⚠ WARNING

Hot hydraulic fluid can cause severe burns.

Allow the hydraulic fluid to cool before performing any maintenance to the hydraulic system.

1. Replace the hydraulic-fluid filters; refer to [Replacing the Hydraulic-Fluid Filters \(page 69\)](#).
2. Clean the area around a hydraulic-hose fitting on the bottom of the hydraulic-fluid tank ([Figure 94](#)).

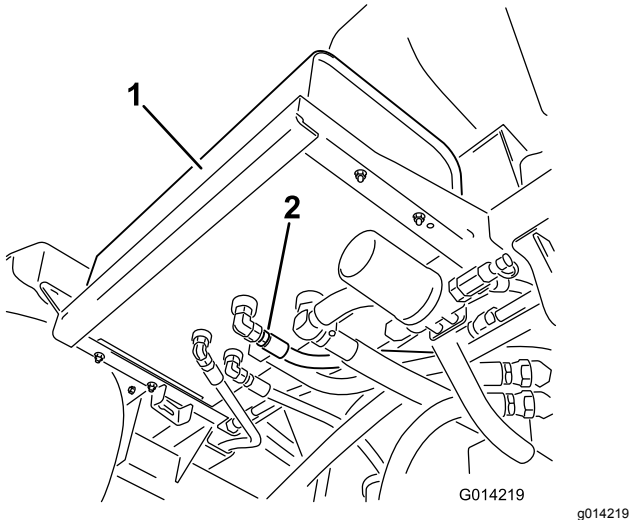

Figure 94

1. Hydraulic tank
 2. Hydraulic hose and fitting
-
3. Place a large drain pan under the hydraulic tank fittings.
 4. Remove the hose fitting from the tank, allowing the fluid to drain into the pan ([Figure 94](#)).
 5. Install the hose and fitting to the tank and tighten it securely.
 6. Fill the hydraulic reservoir with approximately 53 L (14 US gallons) of specified hydraulic fluid or equivalent; refer to [Checking the Hydraulic Fluid \(page 68\)](#).
 7. Start the engine, set the throttle at fast idle, and let the engine run 3 to 5 minutes to purge air from the hydraulic system.

8. Shut off the engine, check the hydraulic-fluid level, and check for leaks.
9. Dispose of the used fluid at a certified recycling center.

Spray System Maintenance

⚠ WARNING

Chemical substances used in the spray system may be hazardous and toxic to you, bystanders, animals, plants, soils or other property.

- Carefully read and follow the chemical warning labels and material safety data sheets (MSDS) for all chemicals used and protect yourself according to the chemical manufacturer's recommendations. For example, use appropriate personal protective equipment (PPE) including face and eye protection, gloves, or other equipment to guard against personal contact with the chemical.
- Keep in mind that there may be more than 1 chemical used and information on each should be assessed.
- *Refuse to operate or work on the sprayer if this information is not available!*
- Before working on a spray system make sure the system has been triple rinsed and neutralized according to the recommendations of the chemical manufacturer(s) and all of the valves have been cycled 3 times.
- Verify there is an adequate supply of clean water and soap nearby, and immediately wash off any chemicals that contact you.

Inspecting the Hoses

Service Interval: Every 200 hours—Inspect all hoses and connections for damage and proper attachment.

Every 400 hours/Yearly (whichever comes first)—Inspect the O-rings in the valve assemblies and replace them if necessary.

Examine each hose in the spray system for cracks, leaks or other damage. At the same time, inspect the connections and fittings for similar damage. Replace any hoses and fittings if damaged.

Changing the Suction Filter

Service Interval: Every 400 hours

Note: Determine the appropriate suction filter mesh size that you need for your job; refer to [Selecting a Suction Filter](#) (page 42).

1. Park the machine on a level surface, engage the parking brake, shut off the pump, shut off the engine, and remove the key.
2. At the top of the sprayer tank, remove the retainer that secures the hose fitting attached to the large hose from the filter housing (Figure 95).

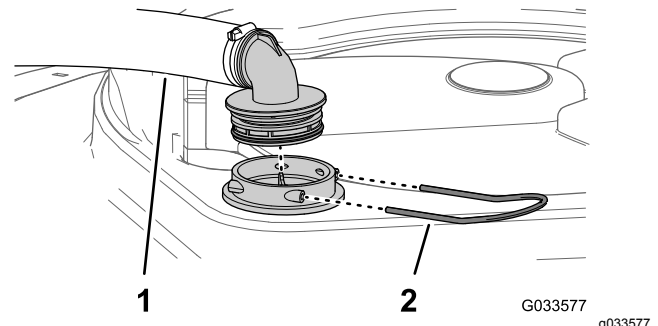

Figure 95

1. Suction hose
2. Retainer

3. Remove the hose and hose fitting from the filter housing (Figure 95).
4. Remove the old suction filter from the filter housing in the tank (Figure 96).

Note: Discard the old filter.

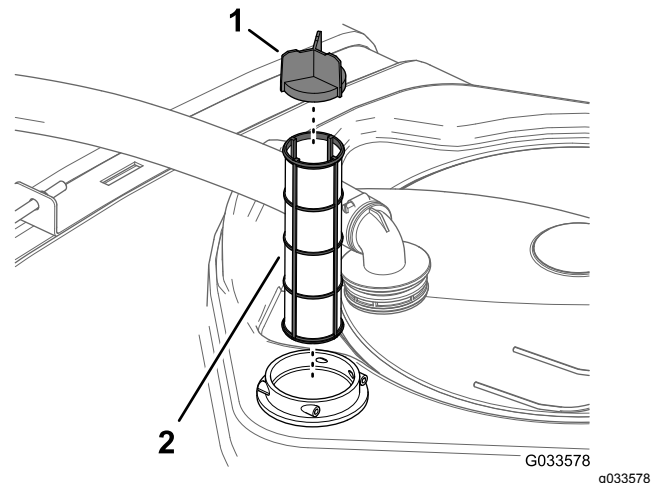

Figure 96

1. Screen vane
2. Suction filter

5. Install the new suction filter into the filter housing.

Note: Ensure that the filter is fully seated.

6. Align the hose and hose fitting to the filter housing at the top of the tank, and secure the

fitting and housing with the retainer that you removed in step 2.

Changing the Pressure Filter

Service Interval: Every 400 hours

1. Move the machine to a level surface, shut off the spray pump, shut off the engine, and remove the key.
2. Align a drain pan under the pressure filter (Figure 97).

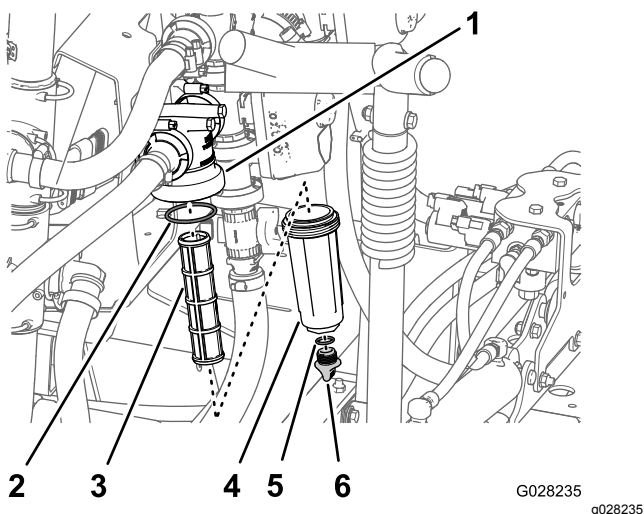

Figure 97

- | | |
|-------------------|------------------------|
| 1. Filter head | 4. Bowl |
| 2. O-ring (bowl) | 5. O-ring (drain plug) |
| 3. Filter element | 6. Drain plug |

3. Rotate the drain plug counterclockwise and remove it from the bowl of the pressure filter (Figure 97).
Note: Allow the bowl to drain completely.
4. Rotate the bowl counterclockwise and remove it from its filter head (Figure 97).
5. Remove the old pressure-filter element (Figure 97).
Note: Discard the old filter.
6. Check the O-ring for the drain plug (located inside the bowl) and the O-ring for the bowl (located inside the filter head) for damage and wear (Figure 97).

Note: Replace any damaged or worn O-rings for the plug, bowl, or both.

7. Install the new pressure-filter element into the filter head (Figure 97).

Note: Ensure that the filter element is firmly seated into the filter head.

8. Install the bowl onto the filter head and tighten by hand (Figure 97).
9. Install the plug into the bowl and tighten by hand (Figure 97).

Changing the Nozzle Filter

Note: Determine the appropriate nozzle filter mesh size that you need for your job; refer to [Selecting a Nozzle-Tip Filter \(Optional\)](#) (page 44).

1. Park the machine on a level surface, engage the parking brake, shut off the sprayer pump, shut off the engine, and remove the key.
2. Remove the nozzle from the spray turret (Figure 98).

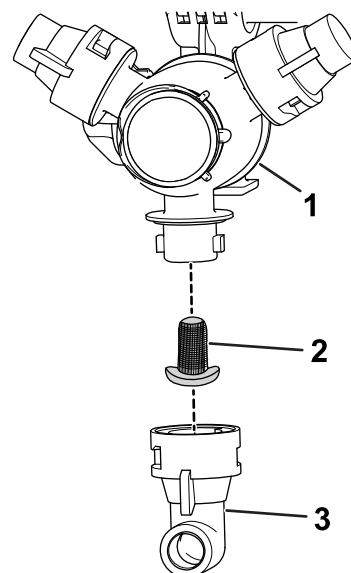

Figure 98

- | | |
|------------------|-----------|
| 1. Spray turret | 3. Nozzle |
| 2. Nozzle filter | |

3. Remove the old nozzle filter (Figure 98).

Note: Discard the old filter.

4. Install the new nozzle filter (Figure 98).

Note: Ensure that the filter is fully seated.

5. Install the nozzle onto the spray turret (Figure 98).

Adjusting the Booms to Level

The following procedure can be used to adjust the actuators on the center boom to keep the left and right booms at level.

1. Extend the booms to the spray position.
2. Remove the cotter pin from the pivot pin (Figure 99).

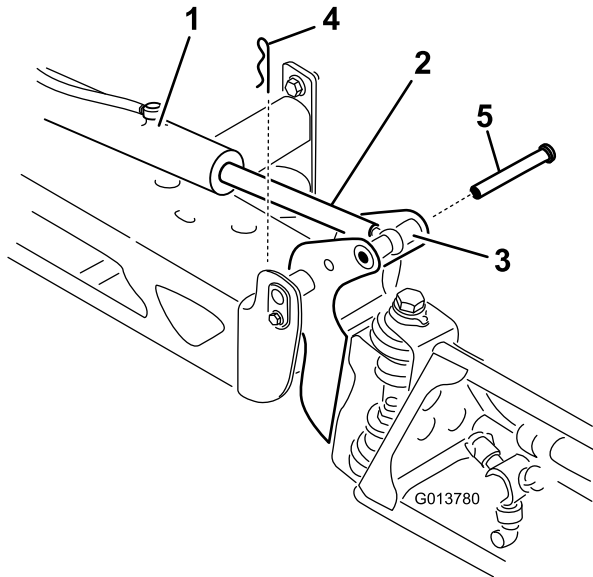

Figure 99

- | | |
|---------------------------|-----------|
| 1. Actuator | 4. Cotter |
| 2. Actuator rod | 5. Pin |
| 3. Boom-pivot pin housing | |

3. Lift up on the boom and remove the pin (Figure 99), and slowly lower the boom to the ground.
4. Inspect the pin for any damage, and replace it if necessary.
5. Use a wrench on the flat sides of the actuator rod to immobilize it, then loosen the jam nut to allow the eyelet rod to be adjusted (Figure 100).

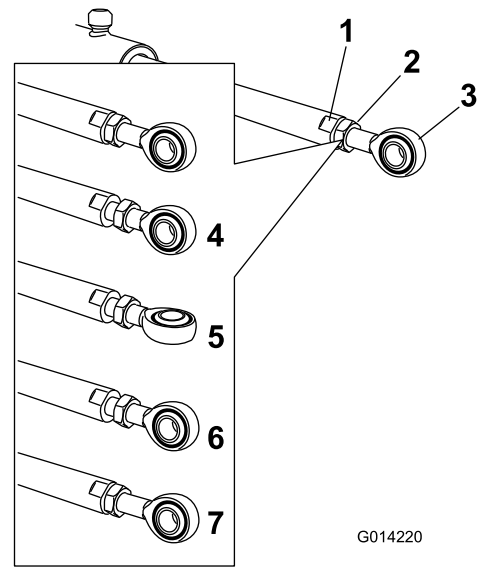

Figure 100

- | | |
|-----------------------------|---|
| 1. Flat on the actuator rod | 5. Eyelet adjusted |
| 2. Jam nut | 6. Eyelet position for assembly |
| 3. Eyelet | 7. Jam nut tightened to lock new position |
| 4. Jam nut loosened | |

6. Turn the eyelet rod in the actuator rod to shorten or lengthen the extended actuator to the desired position (Figure 100).

Note: You must turn the eyelet rod in half or complete revolutions so that you can assemble the rod to the boom.

7. Once the desired position has been achieved, tighten the jam nut to secure the actuator and eyelet rod.
8. Raise the boom to align the pivot with the actuator rod.
9. While holding the boom, insert the pin through both boom pivot and actuator rod (Figure 99).
10. With the pin in place, release the boom and secure the pin with the cotter previously removed.
11. Repeat the procedure for each actuator rod bearing, if necessary.

Inspecting the Nylon Pivot Bushings

Service Interval: Every 400 hours/Yearly (whichever comes first)

1. Park the machine on a level surface, engage the parking brake, shut off the pump, shut off the engine, and remove the key.

- Extend the outer-boom sections to the spray position and support the booms using stands or straps and lifting equipment.
- With the weight of the boom supported, remove the bolt and nut securing the pivot pin to the boom assembly (Figure 101).

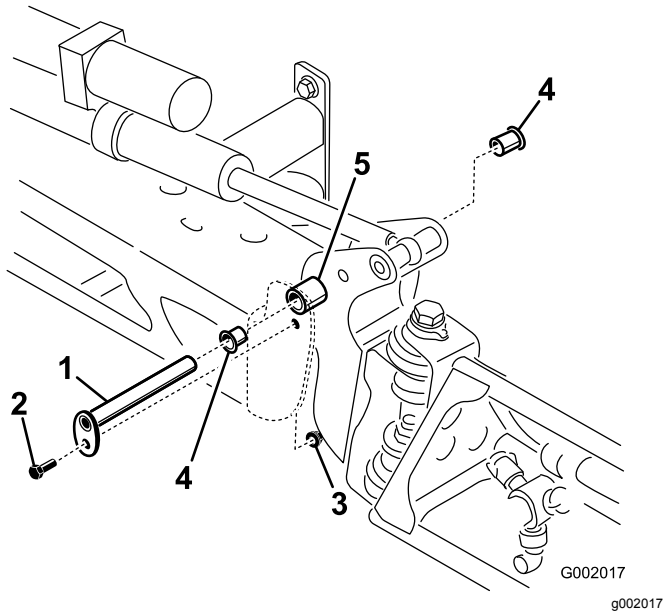

Figure 101

- | | |
|-------------------|---------|
| 1. Nylon bushings | 3. Bolt |
| 2. Pivot pin | |

Pump Maintenance

Inspecting the Pump

Service Interval: Every 400 hours/Yearly (whichever comes first)—Inspect the pump diaphragm and replace if necessary (see an Authorized Toro Service Distributor).

Every 400 hours/Yearly (whichever comes first)—Inspect the pump check valves and replace if necessary (see an Authorized Toro Service Distributor).

Note: The following machine components are considered parts subject to consumption through use unless found defective and are not covered by the warranty associated with this machine.

Have an Authorized Toro Service Distributor check following internal-pump components for damage:

- Pump diaphragm
- Pump check-valve assemblies

Replace any components if necessary.

- Remove the bolt and nut that secure the pivot pin, and remove the pin (Figure 101).
- Remove the boom and pivot bracket assembly from the center frame to access the nylon bushings.
- Remove and inspect the nylon bushings from the front and back sides of the pivot bracket (Figure 101).

Note: Replace any worn or damaged bushings.
- Place a small amount of oil on the nylon bushings, and install them into pivot bracket (Figure 101).
- Install the boom and pivot bracket assembly into the center frame, aligning the holes (Figure 101).
- Install the pivot pin and secure it with the bolt and nut removed in step 4.
- Repeat steps 2 through 9 for the other outer-boom section.

Cleaning

Cleaning the Radiator-Cooling Fins

Service Interval: Every 200 hours—Clean the radiator fins.

Important: Do not spray water into a hot engine compartment, as it may damage the engine.

1. Position the sprayer on a level surface, engage the parking brake, shut off the spray pump, shut off the engine, and remove the key.
2. Tilt the driver and passenger seats forward and align the prop rod into the detent in the prop-rod-guide slot.
3. Allow the cooling system to cool.
4. Remove the seat-base-access cover; refer to [Removing the Seat-Base-Access Panel \(page 50\)](#).
5. Using a soft brush and low-pressure compressed air, clean the fins of the radiator.

Note: Clean the radiator fins more often if needed. Check all coolant hoses and replace any that are worn, leaking, or damaged.

6. Lower the driver and passenger seats.
7. Install the seat-base-access cover; refer to [Installing the Seat-Base-Access Panel \(page 50\)](#).

Cleaning the Flow meter

Service Interval: Every 200 hours/Yearly (whichever comes first) (more often when using wettable powders).

1. Thoroughly rinse and drain the entire spraying system.
2. Remove the flow meter from the sprayer and flush it with clean water.
3. Remove the retainer ring on the upstream side ([Figure 102](#)).

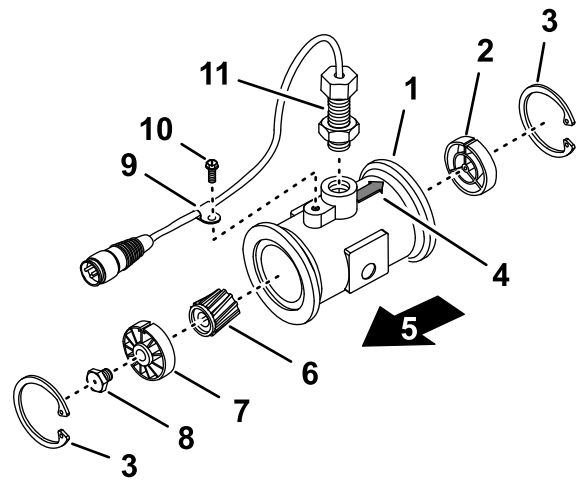

g214630

Figure 102

- | | |
|--|--|
| 1. Flange (flow-meter body) | 7. Upstream hub and bearing (with keyway up) |
| 2. Downstream hub (with keyway up) | 8. Turbine stud |
| 3. Retaining ring | 9. Wire-harness clamp |
| 4. Down stream arrow (flow-meter body) | 10. Flange-head screw |
| 5. Upstream | 11. Sensor assembly |
| 6. Rotor/magnet | |

4. Clean the turbine and the turbine hub to remove metal filings and any wettable powders.
5. Inspect the turbine blades for wear.
Note: Hold the turbine in your hand and spin it. It should spin freely with very little drag. If it does not, replace it.
6. Assemble the flow meter.
7. Use a low pressure (50 kPa or 5 psi) air jet to ensure that the turbine spins freely.

Note: If the turbine does not spin freely, loosen the hex stud on the bottom of the turbine hub by 1/16 of a turn until it does spins freely.

Cleaning the Agitation and Section Valves

- To clean the agitation valve; refer to the following sections:
 1. [Removing the Valve Actuator \(page 76\)](#)
 2. [Removing the Agitation-Manifold Valve \(page 76\)](#)
 3. [Cleaning the Manifold Valve \(page 78\)](#)
 4. [Assembling the Manifold Valve \(page 80\)](#)
 5. [Installing the Agitation-Manifold Valve \(page 81\)](#)

6. [Installing the Valve Actuator \(page 82\)](#)

- To clean the 3 section valves; refer to the following sections:

- [Removing the Valve Actuator \(page 76\)](#)
- [Removing the Section-Manifold Valve \(page 77\)](#)
- [Cleaning the Manifold Valve \(page 78\)](#)
- [Assembling the Manifold Valve \(page 80\)](#)
- [Installing the Section-Manifold Valve \(page 80\)](#)
- [Installing the Valve Actuator \(page 82\)](#)

Removing the Valve Actuator

- Position the sprayer on a level surface, engage the parking brake, shut off the spray pump, shut off the engine, and remove the key.
- Remove the retainer that secures the actuator to the manifold valve for the section valve or agitation valve ([Figure 103](#)).

Note: Squeeze the 2 legs of the retainer together while pushing it down.

Note: Retain the actuator and retainer for installation in [Installing the Valve Actuator \(page 82\)](#).

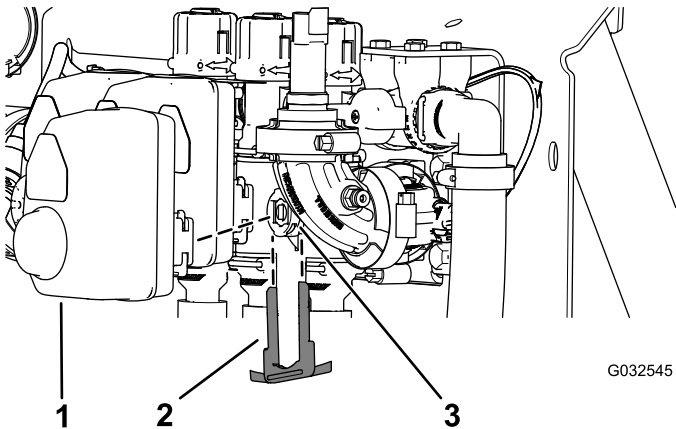

Figure 103

Section-Valve Actuator Shown (the agitation valve actuator is similar)

- Actuator (section valve)
- Retainer
- Stem port

- Remove the actuator from the manifold valve.

Removing the Agitation-Manifold Valve

- Remove the quick connect pin that secures the quick-connect coupler for the agitation hose to the manifold for the agitation valve ([Figure 104](#)).

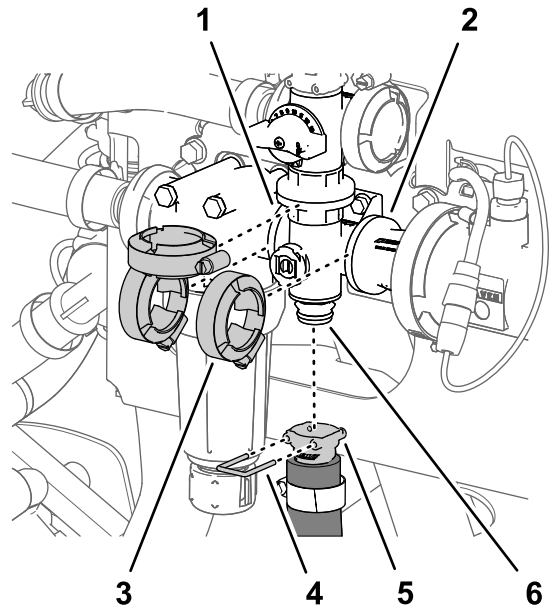

Figure 104

- | | |
|----------------------------------|---|
| 1. Flange (pressure-filter head) | 4. Quick-connect pin |
| 2. Flange (coupling adapter) | 5. Quick-connect coupler (agitation hose) |
| 3. Flange clamp | 6. Quick-connect fitting (agitation-valve manifold) |

- Remove the 3 flange clamps that secure the agitation-valve manifold to the flanges of the pressure-filter head and the coupling adapter ([Figure 104](#)).
- Remove the 2 flange-head bolts (1/4 x 3/4 inch) and 2 flange locknuts (1/4 inch) that secure the agitation-valve manifold to the valve support ([Figure 105](#)).

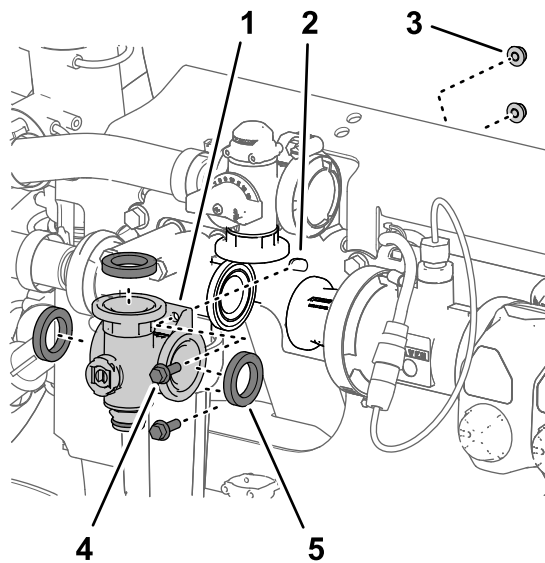

Figure 105

g191302

- | | |
|-------------------------------|--------------------------------------|
| 1. Manifold (agitation valve) | 4. Flange-head bolt (1/4 x 3/4 inch) |
| 2. Valve support | 5. Gasket |
| 3. Flange locknut (1/4 inch) | |

4. Remove the agitation-valve manifold and gaskets from the machine (Figure 105).

Note: If needed, loosen the mounting hardware for the pressure-filter head as needed to provide clearance.

Note: Retain the flange clamps, gaskets and quick-connect pins for installation in [Installing the Agitation-Manifold Valve \(page 81\)](#).

Removing the Section-Manifold Valve

1. Remove the quick-connect pin that secures the quick-connect coupler for the section-bypass valve to the section-manifold valve (Figure 106).

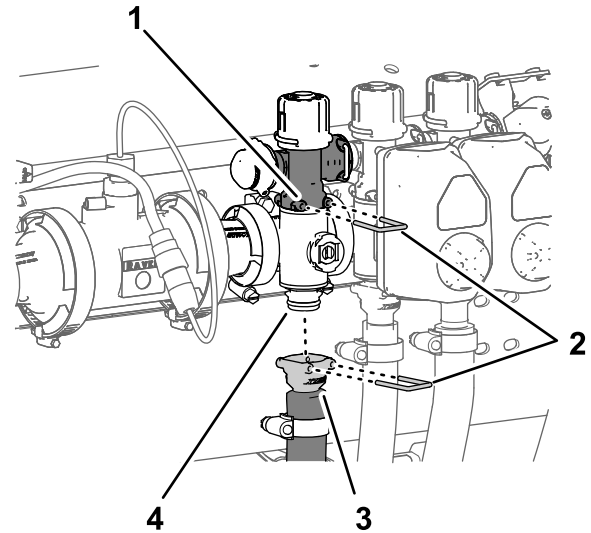

Figure 106

g191303

- | | |
|-------------------------|---|
| 1. Section-bypass valve | 3. Quick-connect coupler (section supply hose) |
| 2. Quick-connect pins | 4. Quick-connect fitting (agitation valve manifold) |

2. Remove the quick connect pin that secures the quick-connect coupler for the section supply hose to the manifold for the quick-connect fitting of the section-manifold valve (Figure 106).
3. Remove the 2 flange clamps that secure the section-manifold valve to the flanges of the adjacent components (Figure 107).

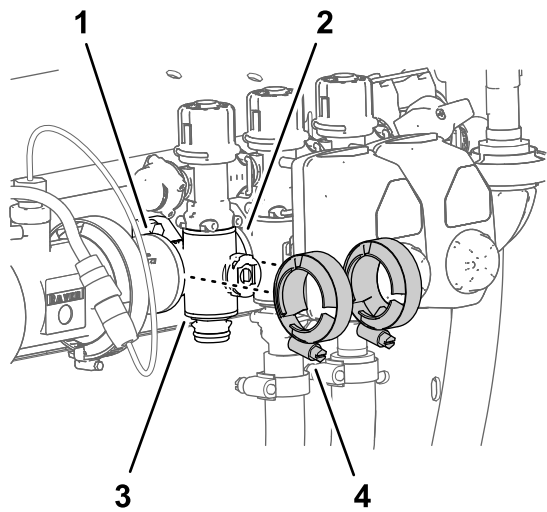

Figure 107

g191300

- | | |
|------------------------------------|---------------------------|
| 1. Flange (coupling adapter) | 3. Section-manifold valve |
| 2. Flange (section-manifold valve) | 4. Flange clamps |

4. For left or right section-valve manifolds, remove the 2 flange-head bolts (1/4 x 3/4 inch) and 2 flange locknuts (1/4 inch) that secure the section-valve manifold to the valve support (Figure 108).

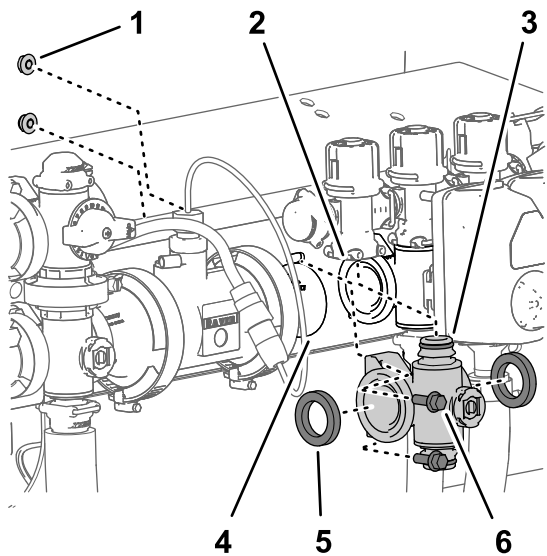

Figure 108

g191304

- | | |
|--|--|
| 1. Flange locknut (1/4 inch—left and right section-valve manifold positions) | 4. Flange (coupling adapter) |
| 2. Section-bypass valve | 5. Gasket |
| 3. Quick-connect fitting (section-valve manifold) | 6. Flange-head bolt (1/4 x 3/4 inch—left and right section-valve manifold positions) |

5. Move the section-valve manifold and gaskets down to clear the section-bypass valve and then away from the machine (Figure 108).

Note: If needed, loosen the mounting hardware for the left or right section-valve manifolds as needed to provide clearance.

Note: Retain the flange clamps, gaskets and quick-connect pins for installation in [Installing the Section-Manifold Valve](#) (page 80).

Cleaning the Manifold Valve

1. Position the valve stem so that it is in the closed position (Figure 109B).

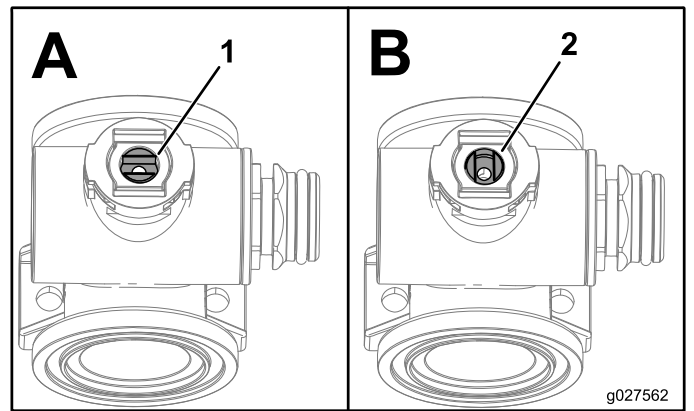

Figure 109

g027562

g027562

1. Valve open 2. Valve closed

2. Remove the 2 end-cap-fitting assemblies from each end of the manifold body (Figure 110 and Figure 111).

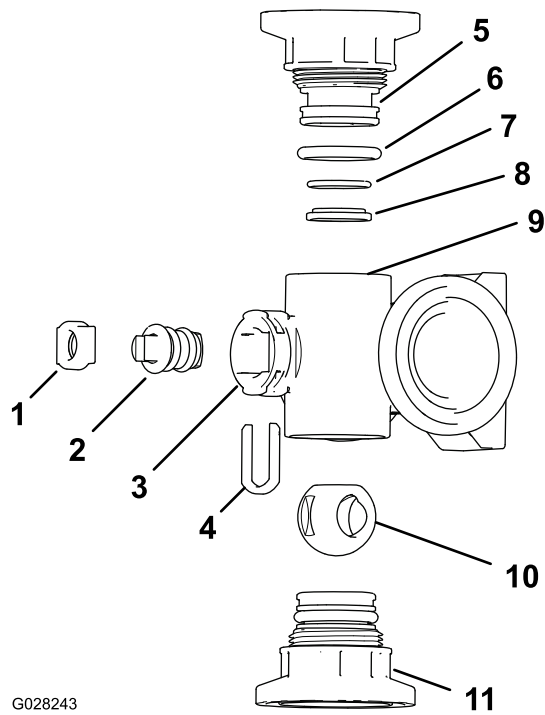

G028243

g028243

Figure 110

Agitation Valve Manifold

- | | |
|---|--|
| 1. Stem retainer | 7. Back seating O-ring (0.676 x 0.07 inch) |
| 2. Valve stem | 8. Valve-seat ring |
| 3. Stem port | 9. Manifold body |
| 4. Stem-capture retainer | 10. Ball valve |
| 5. End-cap fitting | 11. End-cap-fitting assembly |
| 6. End-cap seal O-ring (0.796 x 0.139 inch) | |

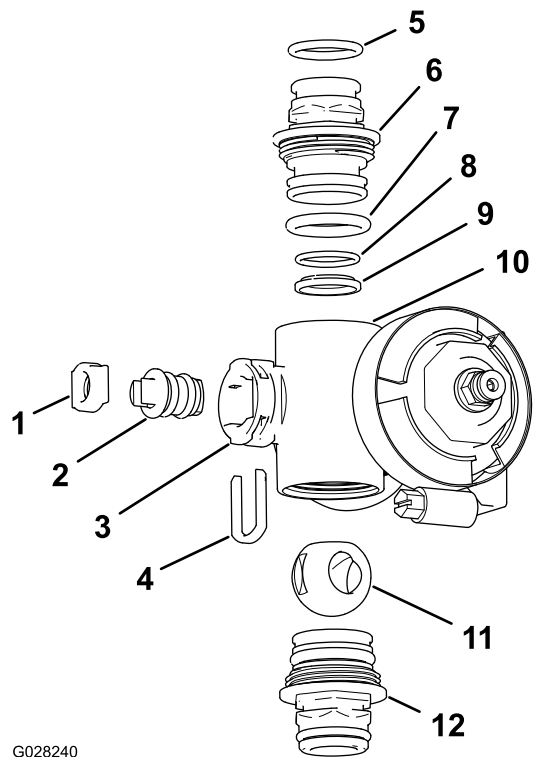

G028240

g028240

Figure 111

Section Valve Manifold

- | | |
|---|--|
| 1. Valve-stem seat | 7. End-cap O-ring (0.796 x 0.139 inch) |
| 2. Valve-stem assembly | 8. Back seating O-ring (0.676 x 0.07 inch) |
| 3. Stem port | 9. Ball seat |
| 4. Stem retainer | 10. Manifold body |
| 5. Outlet fitting O-ring (0.737 x 0.103 inch) | 11. Ball valve |
| 6. Coupling (manifold) | 12. Coupling assembly (manifold) |

3. Turn the valve stem so that the ball is in the open position (Figure 109A).

Note: When the valve stem is parallel with the valve flow, the ball slides out.
4. Remove the stem retainer from the slots in the stem port in the manifold (Figure 110 and Figure 111).
5. Remove the stem retainer and valve stem seat from the manifold (Figure 110 and Figure 111).
6. Reach into the manifold body and remove the valve-stem assembly (Figure 110 and Figure 111).
7. Clean the inside of the manifold and exterior of the ball valve, valve-stem assembly, stem capture, and end fittings.

Assembling the Manifold Valve

1. Check the condition of the outlet fitting O-rings (**section-valve manifold only**), end cap O-rings, back seating O-rings, and ball seat for damage or wear ([Figure 110](#) and [Figure 111](#)).
Note: Replace any damaged or worn O-rings or seats.
2. Apply grease to the valve stem and insert it into the valve-stem seat ([Figure 110](#) and [Figure 111](#)).
3. Install the valve stem and seat it into the manifold and secure the stem and seat with the stem retainer ([Figure 110](#) and [Figure 111](#)).
4. Ensure that the back seating O-ring and the ball seat are aligned and seated into the end-cap fitting ([Figure 110](#) and [Figure 111](#)).
5. Install the end-cap-fitting assembly onto the manifold body until the flange of the end-cap fitting touches the manifold body, then turn the end-cap fitting an additional 1/8 to 1/4 turn ([Figure 110](#) and [Figure 111](#)).

Note: Use caution to prevent damaging the end of the fitting.

6. Insert the ball into the valve body ([Figure 112](#)).

Note: The valve stem should fit inside the ball-drive slot. If the valve stem does not fit, adjust the position of the ball ([Figure 112](#)).

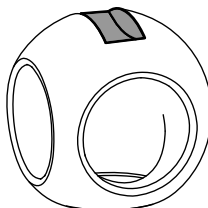
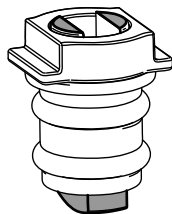

g027565

g027565

Figure 112

7. Turn the valve-stem assembly so that the valve is closed (B of [Figure 109](#)).
8. Repeat steps 4 and 5 for the other end-cap-fitting assembly.

Installing the Section-Manifold Valve

1. Align the 2 gaskets that you removed in [Removing the Section-Manifold Valve](#) (page 77) to the flanges of the section-valve manifold ([Figure 113](#)).

Note: If needed, loosen the mounting hardware for the left or right section-valve manifolds as needed to provide clearance.

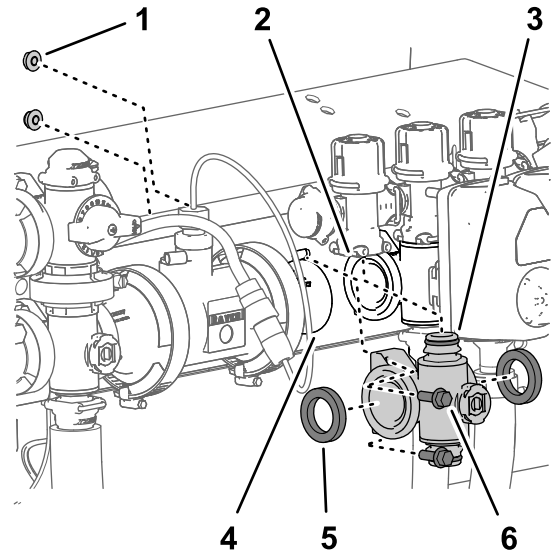

g191304

Figure 113

- | | |
|--|--|
| 1. Flange locknut (1/4 inch—left and right section-valve manifold positions) | 4. Flange (coupling adapter) |
| 2. Section-bypass valve | 5. Gasket |
| 3. Quick-connect fitting (section-valve manifold) | 6. Flange-head bolt (1/4 x 3/4 inch—left and right section-valve manifold positions) |

2. Align the flange of the section-valve manifold between the flanges of the other section-valve (s) and/or coupling adapter ([Figure 113](#)).
3. Assemble the quick-connect fitting of the section-valve manifold to the quick-disconnect socket of the section-bypass valve with a quick-connect pin ([Figure 113](#) and [Figure 114](#)).

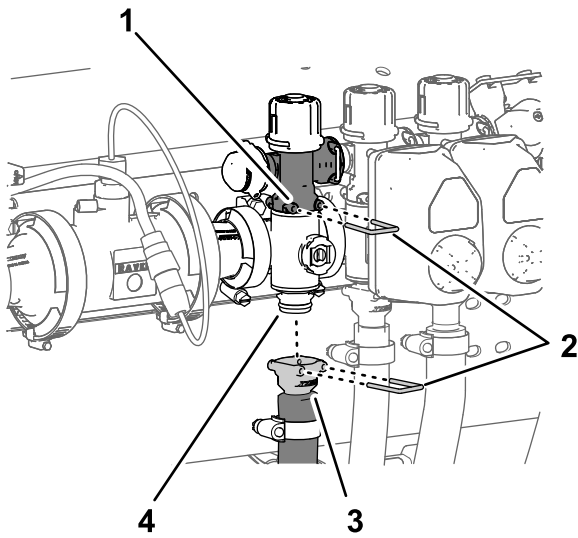

Figure 114

g191303

- | | |
|-------------------------|---|
| 1. Section-bypass valve | 3. Quick-connect coupler (section supply hose) |
| 2. Quick-connect pins | 4. Quick-connect fitting (agitation valve manifold) |

4. Loosely assemble the flange clamps that you removed in [Removing the Section-Manifold Valve \(page 77\)](#) to the flanges of the section-valve manifold and the flanges of the other section-valve (s) and/or coupling adapter ([Figure 115](#)).

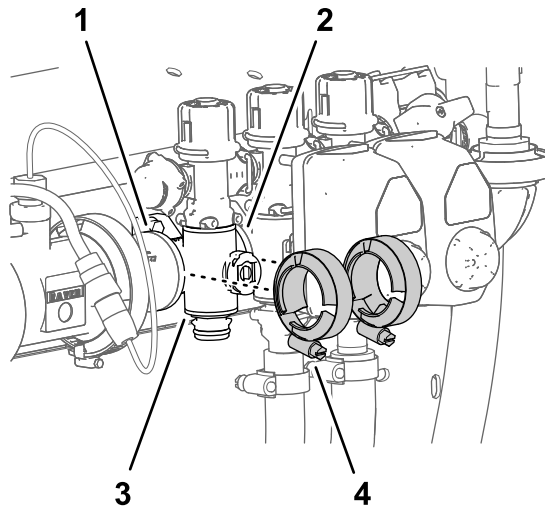

Figure 115

g191300

- | | |
|------------------------------------|---------------------------|
| 1. Flange (coupling adapter) | 3. Section-manifold valve |
| 2. Flange (section-manifold valve) | 4. Flange clamps |

5. For left or right section-valve manifolds, assemble the section-valve manifold to the valve support ([Figure 113](#)) with the 2 flange-head bolts (1/4 x 3/4 inch) and 2 flange locknuts (1/4 inch) that you removed in [Removing the Section-Manifold Valve \(page 77\)](#).

6. Torque the flange-head bolts and flange locknuts to 1978 to 2542 N·cm (175 to 225 in-lb).
7. Tighten the 2 flange clamps by hand ([Figure 115](#)).
8. Assemble the quick-connect coupler of the section hose onto the quick-connect fitting of the section-valve manifold with the quick-connect pin ([Figure 114](#)).
9. If you loosened the mounting hardware of the left or right section-valve manifolds, tighten the nut and bolt to 1978 to 2542 N·cm (175 to 225 in-lb).

Installing the Agitation-Manifold Valve

1. Align the flange of the agitation-valve manifold and 3 gaskets with the flanges of the agitation-bypass valve, pressure filter head, and coupling adapter ([Figure 116](#) and [Figure 117](#)).

Note: If needed, loosen the mounting hardware for the pressure-filter head as needed to provide clearance.

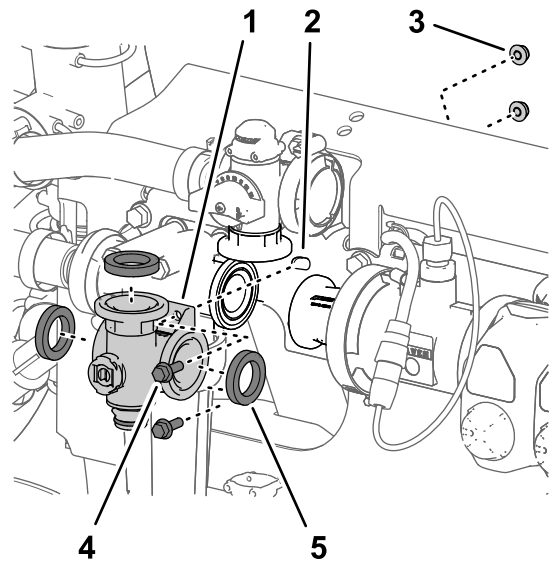

Figure 116

g191302

- | | |
|-------------------------------|--------------------------------------|
| 1. Manifold (agitation valve) | 4. Flange-head bolt (1/4 x 3/4 inch) |
| 2. Valve support | 5. Gasket |
| 3. Flange locknut (1/4 inch) | |

Installing the Valve Actuator

1. Align the actuator to the manifold valve ([Figure 103](#)).
2. Secure the actuator and valve with the retainer that you removed in step 2 of [Removing the Valve Actuator \(page 76\)](#).

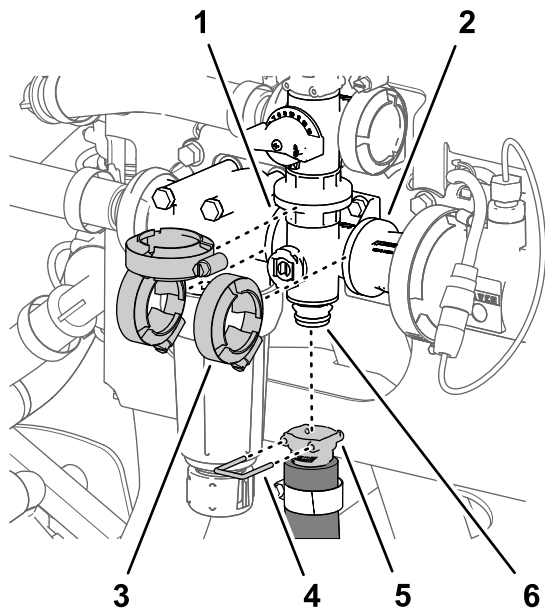

g191301

Figure 117

- | | |
|----------------------------------|---|
| 1. Flange (pressure-filter head) | 4. Quick-connect pin head |
| 2. Flange (coupling adapter) | 5. Quick-connect coupler (agitation hose) |
| 3. Flange clamp | 6. Quick-connect fitting (agitation valve manifold) |

2. Loosely secure the agitation-valve manifold to the agitation-bypass valve, pressure filter head, and coupling adapter ([Figure 117](#)) with the 3 flange clamps that you removed in [Removing the Agitation-Manifold Valve \(page 76\)](#).
3. Assemble the agitation-valve manifold to the valve support with the 2 flange-head bolt (1/4 x 3/4 inch) and flange locknut (1/4 inch) that you removed in [Removing the Agitation-Manifold Valve \(page 76\)](#).
4. Torque the flange-head bolts and flange locknuts to 1978 to 2542 N·cm (175 to 225 in-lb).
5. Tighten the 3 flange clamps by hand ([Figure 117](#)).
6. Assemble the quick-connect coupler of the agitation hose onto the quick-connect fitting of the agitation-valve manifold with the quick-connect pin ([Figure 117](#)).
7. If you loosened the mounting hardware for the pressure-filter head, tighten the nut and bolt to 1978 to 2542 N·cm (175 to 225 in-lb).

Storage

1. Position the sprayer on a level surface, engage the parking brake, shut off the spray pump, shut off the engine, and remove the key.
2. Clean the dirt and grime from the entire machine, including the outside of the cylinder-head fins and blower housing of the engine.

Important: You can wash the machine with mild detergent and water. Do not use high-pressure water to wash the machine. Pressure washing may damage the electrical system or wash away necessary grease at friction points. Avoid excessive use of water, especially near the control panel, lights, engine, and the battery.

3. Condition the sprayer system as follows:
 - A. Drain the fresh-water tank.
 - B. Drain the spray system as completely as possible.
 - C. Prepare rust inhibiting, non-alcohol based, RV antifreeze solution per the manufacturer's instructions.
 - D. Add the RV antifreeze solution to the fresh-water tank and the sprayer tank.
 - E. Run the spray pump for a few minutes to circulate the RV antifreeze throughout the spray system and any installed spray accessories.
 - F. Turn on the 3 section switches.
 - G. Turn the master section switch to the ON position and spray out the nozzle until the RV anti-freeze is visible, then turn the master section switch to the OFF position.
 - H. Drain the fresh-water tank and spray system as completely as possible.
4. Use the boom-section lift switches to raise the outer boom sections. Raise the boom sections until they have moved completely into boom-transport cradle forming the "X" transport position and the lift cylinders are fully retracted.

Note: Make sure that the lift cylinders are fully retracted to prevent actuator rod damage.

5. Perform the following maintenance steps for short-term or long-term storage
 - **Short-term storage** (less than 30 days), clean the sprayer system; refer to [Cleaning the Sprayer System \(page 37\)](#).
 - **Long-term storage** (longer than 30 days), perform the following:

- A. Clean the agitation valve and the 3 section valves; refer to [Cleaning the Agitation and Section Valves \(page 75\)](#).
 - B. Check the brakes; refer to [Adjusting the Brakes \(page 67\)](#).
 - C. Service the air cleaner; refer to [Checking the Air Cleaner \(page 53\)](#).
 - D. Grease the sprayer; refer to [Greasing the Spray Pump \(page 51\)](#).
 - E. Change the engine-oil filter and oil; refer to [Changing the Engine Oil Filter \(page 56\)](#) and [Changing the Engine Oil \(page 56\)](#).
 - F. Check the air pressure in the tires; refer to [Checking the Tire Air Pressure \(page 26\)](#).
 - G. Prepare the fuel system as follows:
 - i. Start the engine and run it at idle speed for approximately 2 minutes.
 - ii. Shut off the engine.
 - iii. Flush the fuel tank with fresh, clean fuel.
 - iv. Secure all the fuel-system fittings.
 - H. Use the starter to crank the engine and distribute the oil inside the cylinder.
 - I. Check and tighten all bolts, nuts, and screws.
- Note:** Repair or replace any parts that are worn or damaged.
- J. Check the condition of all spray hoses.

Note: Replace any hoses that are worn or damaged.
 - K. Tighten all hose fittings.
 - L. Paint all scratched or bare metal surfaces (paint is available from your Authorized Service Dealer).
 - M. Store the machine in a clean, dry storage area.
 - N. Remove the battery from the chassis, check the electrolyte level, and charge the battery fully; refer to [Charging the Battery \(page 62\)](#).

Important: The battery must be fully charged to prevent it from freezing and being damaged at temperatures below 32°F (0°C). A fully charged battery maintains its charge for about

50 days at temperatures lower than 4°C (40°F). If the temperatures will be above 4°C (40°F), check the water level in the battery and charge it every 30 days.

Note: Do not connect the battery cables to the battery posts during storage.

- O. Remove the key from the starter switch and put the key in a safe place out of the reach of children.
- P. Cover the machine to protect it and keep it clean.

Troubleshooting

Troubleshooting the Engine and Vehicle

Problem	Possible Cause	Corrective Action
The starter does not rotate the engine.	<ol style="list-style-type: none"> 1. The electrical connections are corroded or loose. 2. A fuse is blown or loose. 3. The battery is discharged. 4. A broken starter or starter solenoid. 5. There are seized internal engine components. 	<ol style="list-style-type: none"> 1. Check the electrical connections for good contact. 2. Correct or replace fuse. 3. Charge or replace the battery. 4. Contact your Authorized Service Dealer. 5. Contact your Authorized Service Dealer.
The engine cranks but does not start.	<ol style="list-style-type: none"> 1. The fuel tank is empty. 2. Dirt, water, or stale fuel is in the fuel system. 3. Clogged fuel line. 4. The run relay is not energized. 5. The starter switch is broken. 	<ol style="list-style-type: none"> 1. Fill the tank with fresh fuel. 2. Drain and flush the fuel system; add fresh fuel. 3. Clean or replace. 4. Contact your Authorized Service Dealer. 5. Contact your Authorized Service Dealer.
The engine starts but does not keep running.	<ol style="list-style-type: none"> 1. The fuel-tank vent is restricted. 2. Dirt or water is in the fuel system. 3. The fuel filter is clogged. 4. A fuse is blown or loose. 5. The fuel pump is broken. 6. There are loose wires or poor connections. 7. The cylinder-head gasket is broken. 	<ol style="list-style-type: none"> 1. Replace the fuel cap. 2. Drain and flush the fuel system; add fresh fuel. 3. Replace the fuel filter. 4. Correct or replace the fuse. 5. Contact your Authorized Service Dealer. 6. Check and tighten wire connections. 7. Contact your Authorized Service Dealer.
The engine runs but knocks or misses.	<ol style="list-style-type: none"> 1. Dirt, water, or stale fuel in the fuel system. 2. There are loose wires or poor connections. 3. The engine is overheating. 	<ol style="list-style-type: none"> 1. Drain and flush the fuel system; add fresh fuel. 2. Check and tighten wire connections. 3. See "The engine overheats" below.
The engine does not idle.	<ol style="list-style-type: none"> 1. The fuel-tank vent is restricted. 2. Dirt, water, or stale fuel is in the fuel system. 3. The fuel pump is broken. 4. The engine has low compression. 5. The air-filter element is dirty. 	<ol style="list-style-type: none"> 1. Replace the fuel cap. 2. Drain and flush the fuel system; add fresh fuel. 3. Contact your Authorized Service Dealer. 4. Contact your Authorized Service Dealer. 5. Replace the air-filter element.

Problem	Possible Cause	Corrective Action
The engine overheats.	<ol style="list-style-type: none"> 1. The crankcase-oil level is incorrect. 2. The coolant level is low. 3. The engine is operated under excessive load. 4. The air-intake screens are dirty. 5. The cooling fins and air passages under the engine-blower housing and/or the rotating-air-intake screen are plugged. 	<ol style="list-style-type: none"> 1. Fill or drain to the Full mark. 2. Check the coolant level and replenish it as needed. 3. Reduce load; use lower ground speed. 4. Clean with the air-intake screens with every use. 5. Clean the cooling fins and air passages with every use.
The engine loses power.	<ol style="list-style-type: none"> 1. The crankcase-oil level is incorrect. 2. The air-cleaner element is dirty. 3. Dirt, water, or stale fuel is in the fuel system. 4. The engine is overheated. 5. The vent hole in the fuel-tank-vent fitting is plugged. 6. The engine has low compression. 	<ol style="list-style-type: none"> 1. Fill or drain to the Full mark. 2. Replace the air-cleaner element. 3. Drain and flush the fuel system; add fresh fuel. 4. See "The engine overheats" above. 5. Replace the fuel cap. 6. Contact your Authorized Service Dealer.
There is abnormal vibration or noise.	<ol style="list-style-type: none"> 1. The engine-mounting bolts are loose. 2. There is a problem with the engine. 	<ol style="list-style-type: none"> 1. Tighten the engine-mounting bolts. 2. Contact your Authorized Service Dealer.
The machine does not operate or is sluggish in either direction because the engine bogs down or stalls.	<ol style="list-style-type: none"> 1. The parking brake is set. 	<ol style="list-style-type: none"> 1. Release the parking brake.
The machine does not operate in either direction.	<ol style="list-style-type: none"> 1. The parking brake was not released or the parking brake is not releasing. 2. The transmission is broken. 3. The control linkage needs adjustment or replacement. 4. The drive shaft or wheel hub key has been damaged. 	<ol style="list-style-type: none"> 1. Release the parking brake or check the linkage. 2. Contact your Authorized Service Dealer. 3. Contact your Authorized Service Dealer. 4. Contact your Authorized Service Dealer.

Troubleshooting the Spray System

Problem	Possible Cause	Corrective Action
A spray section does not spray.	<ol style="list-style-type: none"> 1. The electrical connection on the spray section valve is dirty or disconnected. 2. The fuse is open (blown) or loose. 3. There is a pinched hose. 4. A spray section-bypass valve is improperly adjusted. 5. The spray section valve is damaged. 6. The electrical system is damaged. 	<ol style="list-style-type: none"> 1. Turn the valve off manually. Disconnect the electrical connector on the valve and clean all leads, then reconnect it. 2. Check the fuses and replace them as necessary. 3. Repair or replace the hose. 4. Adjust the section-bypass valves. 5. Contact your Authorized Service Dealer. 6. Contact your Authorized Service Dealer.
A spray section does not turn off.	<ol style="list-style-type: none"> 1. The valve is damaged. 	<ol style="list-style-type: none"> 1. Disassemble the sprayer-section valve; refer to the section Cleaning the Sprayer Valves. Inspect all of the parts and replace any that are damaged.

Problem	Possible Cause	Corrective Action
A spray section valve is leaking.	<ol style="list-style-type: none"> 1. An O-ring is deteriorated. 2. A valve seat is worn or damaged. 	<ol style="list-style-type: none"> 1. Disassemble the valve and replace the seals using the Valve Repair Kit; contact your Authorized Service Dealer. 2. Remove the valve actuator and replace the valve seals and seat using the Valve Repair Kit; contact your Authorized Service Dealer.
The pressure drops when you turn on a spray section.	<ol style="list-style-type: none"> 1. The section-bypass valve is improperly adjusted. 2. There is an obstruction in the section-valve body. 3. A nozzle filter is damaged or clogged. 	<ol style="list-style-type: none"> 1. Adjust the section-bypass valve. 2. Remove the inlet and outlet connections to the section valve and remove any obstructions. 3. Remove and inspect all nozzles.
The sprayer pressure drops while spraying.	<ol style="list-style-type: none"> 1. The suction filter screen is clogging or clogged. 	<ol style="list-style-type: none"> 1. Remove and clean or replace suction filter.

Schematics

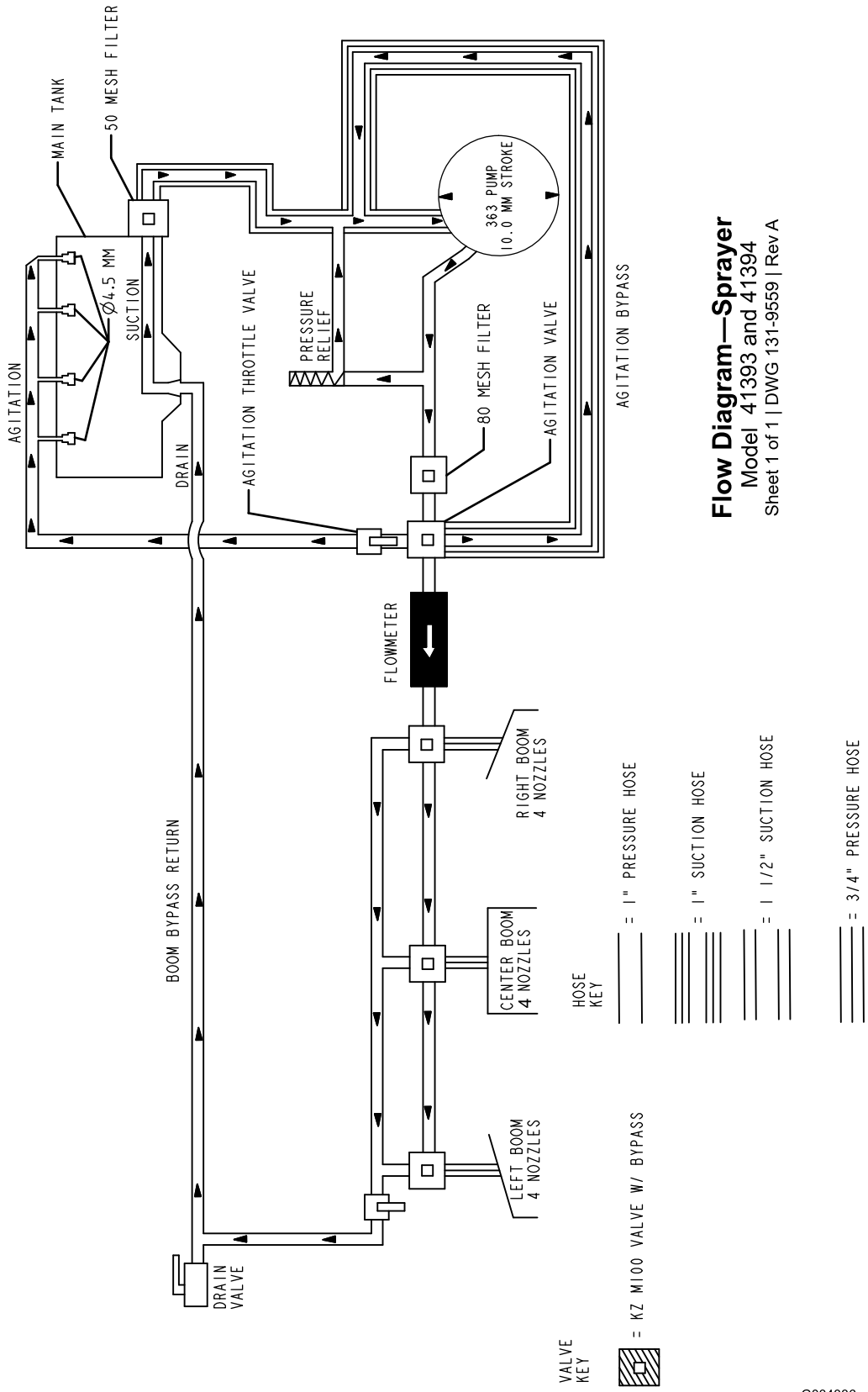

Flow Diagram—Sprayer
 Model 41393 and 41394
 Sheet 1 of 1 | DWG 131-9559 | Rev A

Sprayer System Schematic (Rev. DWG 131-9559 Rev A)

G034336

g034336

Notes:

Notes:

European Privacy Notice

The Information Toro Collects

Toro Warranty Company (Toro) respects your privacy. In order to process your warranty claim and contact you in the event of a product recall, we ask you to share certain personal information with us, either directly or through your local Toro company or dealer.

The Toro warranty system is hosted on servers located within the United States where privacy law may not provide the same protection as applies in your country.

BY SHARING YOUR PERSONAL INFORMATION WITH US, YOU ARE CONSENTING TO THE PROCESSING OF YOUR PERSONAL INFORMATION AS DESCRIBED IN THIS PRIVACY NOTICE.

The Way Toro Uses Information

Toro may use your personal information to process warranty claims, to contact you in the event of a product recall and for any other purpose which we tell you about. Toro may share your information with Toro's affiliates, dealers or other business partners in connection with any of these activities. We will not sell your personal information to any other company. We reserve the right to disclose personal information in order to comply with applicable laws and with requests by the appropriate authorities, to operate our systems properly or for our own protection or that of other users.

Retention of your Personal Information

We will keep your personal information as long as we need it for the purposes for which it was originally collected or for other legitimate purposes (such as regulatory compliance), or as required by applicable law.

Toro's Commitment to Security of Your Personal Information

We take reasonable precautions in order to protect the security of your personal information. We also take steps to maintain the accuracy and current status of personal information.

Access and Correction of your Personal Information

If you would like to review or correct your personal information, please contact us by email at legal@toro.com.

Australian Consumer Law

Australian customers will find details relating to the Australian Consumer Law either inside the box or at your local Toro Dealer.



The Toro Warranty

A Two-Year Limited Warranty

Conditions and Products Covered

The Toro Company and its affiliate, Toro Warranty Company, pursuant to an agreement between them, jointly warrant your Toro Commercial product ("Product") to be free from defects in materials or workmanship for two years or 1500 operational hours*, whichever occurs first. This warranty is applicable to all products with the exception of Aerators (refer to separate warranty statements for these products). Where a warrantable condition exists, we will repair the Product at no cost to you including diagnostics, labor, parts, and transportation. This warranty begins on the date the Product is delivered to the original retail purchaser.

* Product equipped with an hour meter.

Instructions for Obtaining Warranty Service

You are responsible for notifying the Commercial Products Distributor or Authorized Commercial Products Dealer from whom you purchased the Product as soon as you believe a warrantable condition exists. If you need help locating a Commercial Products Distributor or Authorized Dealer, or if you have questions regarding your warranty rights or responsibilities, you may contact us at:

Toro Commercial Products Service Department
Toro Warranty Company
8111 Lyndale Avenue South
Bloomington, MN 55420-1196
952-888-8801 or 800-952-2740
E-mail: commercial.warranty@toro.com

Owner Responsibilities

As the Product owner, you are responsible for required maintenance and adjustments stated in your *Operator's Manual*. Failure to perform required maintenance and adjustments can be grounds for disallowing a warranty claim.

Items and Conditions Not Covered

Not all product failures or malfunctions that occur during the warranty period are defects in materials or workmanship. This warranty does not cover the following:

- Product failures which result from the use of non-Toro replacement parts, or from installation and use of add-on, or modified non-Toro branded accessories and products. A separate warranty may be provided by the manufacturer of these items.
- Product failures which result from failure to perform recommended maintenance and/or adjustments. Failure to properly maintain your Toro product per the Recommended Maintenance listed in the *Operator's Manual* can result in claims for warranty being denied.
- Product failures which result from operating the Product in an abusive, negligent, or reckless manner.
- Parts subject to consumption through use unless found to be defective. Examples of parts which are consumed, or used up, during normal Product operation include, but are not limited to, brake pads and linings, clutch linings, blades, reels, rollers and bearings (sealed or greasable), bed knives, spark plugs, castor wheels and bearings, tires, filters, belts, and certain sprayer components such as diaphragms, nozzles, and check valves, etc.
- Failures caused by outside influence. Conditions considered to be outside influence include, but are not limited to, weather, storage practices, contamination, use of unapproved fuels, coolants, lubricants, additives, fertilizers, water, or chemicals, etc.
- Failure or performance issues due to the use of fuels (e.g. gasoline, diesel, or biodiesel) that do not conform to their respective industry standards.

Countries Other than the United States or Canada

Customers who have purchased Toro products exported from the United States or Canada should contact their Toro Distributor (Dealer) to obtain guarantee policies for your country, province, or state. If for any reason you are dissatisfied with your Distributor's service or have difficulty obtaining guarantee information, contact the Toro importer.

- Normal noise, vibration, wear and tear, and deterioration.
- Normal "wear and tear" includes, but is not limited to, damage to seats due to wear or abrasion, worn painted surfaces, scratched decals or windows, etc.

Parts

Parts scheduled for replacement as required maintenance are warranted for the period of time up to the scheduled replacement time for that part. Parts replaced under this warranty are covered for the duration of the original product warranty and become the property of Toro. Toro will make the final decision whether to repair any existing part or assembly or replace it. Toro may use remanufactured parts for warranty repairs.

Deep Cycle and Lithium-Ion Battery Warranty:

Deep cycle and Lithium-Ion batteries have a specified total number of kilowatt-hours they can deliver during their lifetime. Operating, recharging, and maintenance techniques can extend or reduce total battery life. As the batteries in this product are consumed, the amount of useful work between charging intervals will slowly decrease until the battery is completely worn out. Replacement of worn out batteries, due to normal consumption, is the responsibility of the product owner. Battery replacement may be required during the normal product warranty period at owner's expense. Note: (Lithium-Ion battery only): A Lithium-Ion battery has a part only prorated warranty beginning year 3 through year 5 based on the time in service and kilowatt hours used. Refer to the *Operator's Manual* for additional information.

Maintenance is at Owner's Expense

Engine tune-up, lubrication, cleaning and polishing, replacement of filters, coolant, and completing recommended maintenance are some of the normal services Toro products require that are at the owner's expense.

General Conditions

Repair by an Authorized Toro Distributor or Dealer is your sole remedy under this warranty.

Neither The Toro Company nor Toro Warranty Company is liable for indirect, incidental or consequential damages in connection with the use of the Toro Products covered by this warranty, including any cost or expense of providing substitute equipment or service during reasonable periods of malfunction or non-use pending completion of repairs under this warranty. Except for the Emissions warranty referenced below, if applicable, there is no other express warranty. All implied warranties of merchantability and fitness for use are limited to the duration of this express warranty.

Some states do not allow exclusions of incidental or consequential damages, or limitations on how long an implied warranty lasts, so the above exclusions and limitations may not apply to you. This warranty gives you specific legal rights, and you may also have other rights which vary from state to state.

Note regarding engine warranty:

The Emissions Control System on your Product may be covered by a separate warranty meeting requirements established by the U.S. Environmental Protection Agency (EPA) and/or the California Air Resources Board (CARB). The hour limitations set forth above do not apply to the Emissions Control System Warranty. Refer to the Engine Emission Control Warranty Statement supplied with your product or contained in the engine manufacturer's documentation for details.