



**Count on it.**

Form No. 3379-524 Rev E

**Operator's Manual**

# Multi Pro 1750 Turf Sprayer

Model No. 41188—Serial No. 314000001 and Up

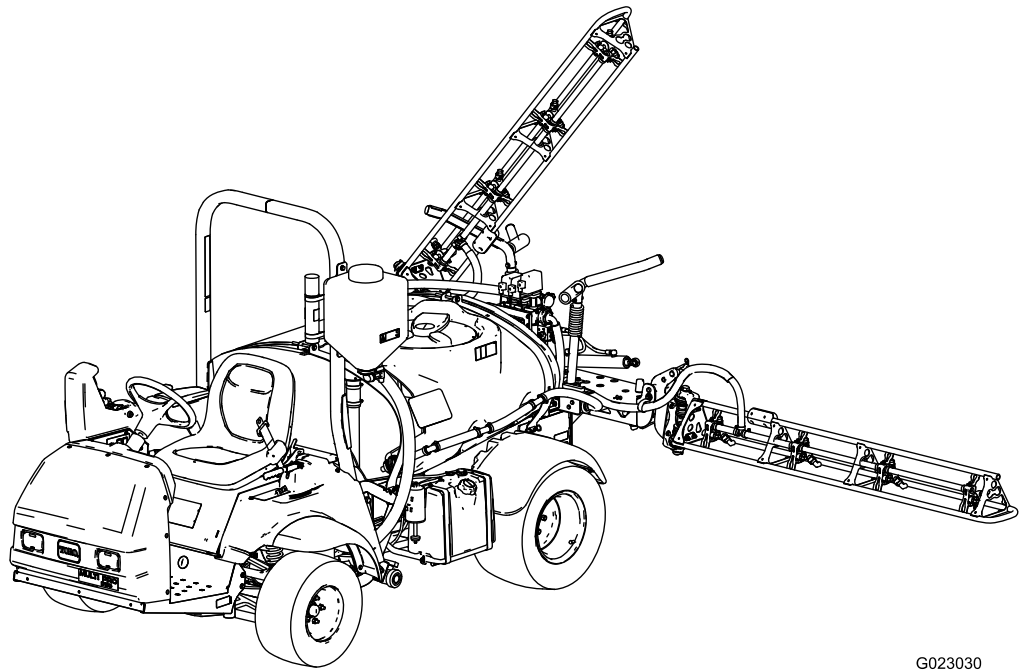

G023030



The Multi Pro turf sprayer is a dedicated turf spray application vehicle and is intended to be used by professional, hired operators in commercial applications. It is primarily designed for spraying on well-maintained lawns in parks, golf courses, sports fields, and on commercial grounds.

This product complies with all relevant European directives; for details, please see the separate product specific Declaration of Conformity (DOC) sheet.

**Important:** This engine is not equipped with a spark arrester muffler. It is a violation of California Public Resource Code Section 4442 to use or operate the engine on any forest-covered, brush-covered, or grass-covered land. Other states or federal areas may have similar laws.

This spark ignition system complies with Canadian ICES-002

The enclosed *Engine Owner's Manual* is supplied for information regarding the US Environmental Protection Agency (EPA) and the California Emission Control Regulation of emission systems, maintenance, and warranty. Replacements may be ordered through the engine manufacturer.

### ⚠ WARNING

#### CALIFORNIA Proposition 65 Warning

The engine exhaust from this product contains chemicals known to the State of California to cause cancer, birth defects, or other reproductive harm.

Battery posts, terminals, and related accessories contain lead and lead compounds, chemicals known to the State of California to cause cancer and reproductive harm. Wash hands after handling.

Use of this product may cause exposure to chemicals known to the State of California to cause cancer, birth defects, or other reproductive harm.

# Introduction

Read this manual carefully to learn how to operate and maintain your product properly. The information in this manual can help you and others avoid injury and product damage. Although Toro designs and produces safe products, you are responsible for operating the product properly and safely. You may contact Toro directly at [www.Toro.com](http://www.Toro.com) for product and accessory information, help finding a dealer, or to register your product.

Whenever you need service, genuine Toro parts, or additional information, contact an Authorized Service Dealer or Toro Customer Service and have the model and serial numbers of your product ready. [Figure 1](#) illustrates the location of the model and serial numbers on the product.

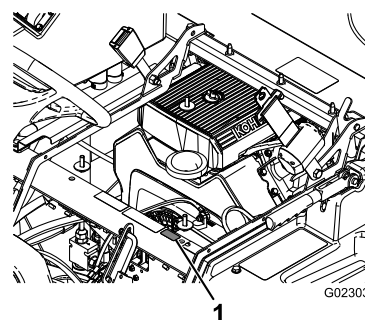

Figure 1

1. Location of the model and serial numbers

Model No. \_\_\_\_\_

Serial No. \_\_\_\_\_

This manual identifies potential hazards and has safety messages identified by the safety alert symbol ([Figure 2](#)), which signals a hazard that may cause serious injury or death if you do not follow the recommended precautions.



Figure 2

1. Safety alert symbol.

This manual uses 2 words to highlight information. **Important** calls attention to special mechanical information and **Note** emphasizes general information worthy of special attention.

# Contents

Safety .....	4	Changing the Spark Plugs .....	43
Safe Operating Practices .....	4	Fuel System Maintenance .....	44
Chemical Safety .....	4	Replacing the Fuel Filter .....	44
Before Operating .....	5	Draining the Fuel Tank .....	44
While Operating .....	5	Electrical System Maintenance .....	45
Maintenance .....	7	Locating the Fuses .....	45
Sound Power .....	7	Servicing the Battery .....	45
Sound Pressure .....	7	Drive System Maintenance .....	47
Hand-Arm Vibration .....	7	Inspecting the Wheels and Tires .....	47
Whole Body Vibration .....	7	Adjusting the Front Wheel Toe-in .....	47
Safety and Instructional Decals .....	8	Brake Maintenance .....	48
Setup .....	14	Checking the Brake Fluid .....	48
1 Installing the Anti-siphon Fill		Inspecting the Brakes .....	48
Receptacle .....	14	Adjusting the Parking Brake .....	48
2 Checking the Boom Hinge Springs .....	15	Hydraulic System Maintenance .....	49
3 Learning More About Your Product .....	16	Checking the Transaxle/Hydraulic	
Product Overview .....	17	Fluid .....	49
Controls .....	19	Changing Transaxle/Hydraulic Fluid .....	49
Specifications .....	22	Replacing the Hydraulic Filter .....	50
Attachments/Accessories .....	22	Spray System Maintenance .....	50
Operation .....	23	Inspecting the Hoses .....	50
Think Safety First .....	23	Inspecting the Pump .....	51
Preparing to Drive the Sprayer for the First		Inspecting the Nylon Pivot Bushings .....	51
Time .....	23	Cleaning .....	52
Pre-Starting Checks .....	24	Cleaning the Flowmeter .....	52
Driving the Sprayer .....	25	Cleaning the Suction Strainer .....	52
Breaking in a New Sprayer .....	25	Storage .....	53
Adjusting the Booms to Level .....	26	Troubleshooting .....	55
Operating the Sprayer .....	26	Schematics .....	58
Filling the Fresh Water Tank .....	27		
Filling the Spray Tank .....	27		
Operating the Booms .....	28		
Spraying .....	28		
Spraying Tips .....	28		
Cleaning the Sprayer .....	28		
Using the InfoCenter LCD Display .....	30		
Calibrating the Sprayer Flow .....	32		
Calibrating the Sprayer Speed .....	32		
Calibrating the Boom Bypass .....	33		
Calibrating the Agitation Bypass Valve .....	33		
Locating the Pump .....	34		
Towing the Sprayer .....	34		
Transporting the Sprayer .....	35		
Maintenance .....	36		
Recommended Maintenance Schedule(s) .....	36		
Daily Maintenance Checklist .....	37		
Notation for Areas of Concern .....	38		
Pre-Maintenance Procedures .....	39		
Jacking the Sprayer .....	39		
Lubrication .....	39		
Greasing the Sprayer .....	39		
Greasing the Boom Hinges .....	39		
Engine Maintenance .....	40		
Checking the Air Intake Screen .....	40		
Servicing the Air Cleaner .....	40		
Servicing the Engine Oil .....	41		

# Safety

Improper use or maintenance by the operator or owner can result in injury. To reduce the potential for injury, comply with these safety instructions and always pay attention to the safety alert symbol, which means CAUTION, WARNING, or DANGER—personal safety instruction. Failure to comply with the instruction may result in personal injury or death.

Supervisors, operators, and service persons should be familiar with the following standards and publications: (The material may be obtained from the address shown).

- Flammable and Combustible Liquids Code: ANSI/NFPA 30
- National Fire Protection Association: ANSI/NFPA #505; Powered Industrial Trucks National Fire Prevention Association Barrymarch Park Quincy, Massachusetts 02269 U.S.A.
- SAE J2258 Light Utility Vehicles Society of Automotive Engineers SAE World Headquarters 400 Commonwealth Drive Warrendale, PA 15096-0001
- ANSI/UL 558; Internal Combustion Engine Powered Industrial Trucks American National Standards Institute, Inc. 1430 Broadway New York, New York 10018 U.S.A. or Underwriters Laboratories 333 Pfingsten Road Northbrook, Illinois 60062 U.S.A.

## Safe Operating Practices

### **▲ WARNING**

**The sprayer is an off-highway vehicle only and is not designed, equipped, or manufactured for use on public streets, roads, or highways.**

**Do not drive this vehicle on public streets, roads, or highways.**

## Supervisor's Responsibilities

- Make sure that operators are thoroughly trained and familiar with the *Operator's Manual*, Engine Manual, and all labels on the sprayer.
- Establish your own special procedures and work rules for unusual operating conditions (e.g. slopes too steep for sprayer operation).

# Chemical Safety

### **▲ WARNING**

**Chemical substances used in the spray system may be hazardous and toxic to you, bystanders, animals, plants, soils or other property.**

- **Carefully read and follow the chemical warning labels and Material Safety Data Sheets (MSDS) for all chemicals used and protect yourself according to the chemical manufacturer's recommendations. For example, use appropriate Personal Protective Equipment (PPE) including face and eye protection, gloves, or other equipment to guard against personal contact with the chemical.**
- **Keep in mind that there may be more than one chemical used, and information on each chemical should be assessed.**
- **Refuse to operate or work on the sprayer if this information is not available!**
- **Before working on a spray system, make sure that the system has been triple rinsed and neutralized according to the recommendations of the chemical manufacturer(s) and all of the valves have been cycled 3 times.**
- **Verify there is an adequate supply of clean water and soap nearby, and immediately wash off any chemicals that contact you.**
- Obtain proper training before using or handling chemicals.
- Use the correct chemical for the job.
- Follow the chemical manufacturer's instructions for the safe application of the chemical.
- Handle chemicals in a well ventilated area.
- Wear goggles and other protective equipment as instructed by the chemical manufacturer. Ensure that as little skin as possible is exposed while using chemicals.
- Have clean water available especially when filling the spray tank.
- Do not eat, drink, or smoke while working with chemicals.
- Always wash your hands and other exposed areas as soon as possible after finishing the work.

- Properly dispose of unused chemicals and chemical containers as instructed by the chemical manufacturer and your local codes.
- Chemicals and fumes in the tanks are dangerous; never enter the tank or place your head over or in the opening.

## Before Operating

- Operate the machine only after reading and understanding the contents of this manual.
- **Never** allow children to operate the sprayer.
- **Never** allow other adults to operate the sprayer without first reading and understanding the *Operator's Manual*. Only trained and authorized persons should operate this sprayer. Make sure that all operators are physically and mentally capable of operating the sprayer.
- This sprayer is designed to carry **only you**, the operator. **Never** carry any passengers on the sprayer.
- **Never** operate the sprayer when under the influence of drugs or alcohol. Even prescription drugs and cold medicines can cause drowsiness.
- Do not drive the sprayer when you are tired. Be sure to take occasional breaks. It is very important that you stay alert at all times.
- Become familiar with the controls and know how to stop the engine quickly.
- Keep all shields, safety devices, and decals in place. If a shield, safety device, or decal is malfunctioning, illegible, or damaged, repair or replace it before operating the machine.
- Always wear substantial shoes. Do not operate the machine while wearing sandals, tennis shoes, or sneakers. Do not wear loose fitting clothing or jewelry which could get caught in moving parts and cause personal injury.
- Wearing safety glasses, safety shoes, long pants, and a helmet is advisable and required by some local safety and insurance regulations.
- Avoid driving when it is dark, especially in unfamiliar areas. If you must drive when it is dark, be sure to drive cautiously, use the headlights, and even consider adding additional lights.
- Be extremely careful when operating around people. Always be aware of where bystanders might be and keep them away from the work area.
- Before operating the sprayer, always check the designated areas of the sprayer that are stated in the Pre-Starting Checks in the Operation section. If the machine does not function correctly or is damaged in any way, do **not** use the sprayer. Make sure that the problem is corrected before the sprayer or attachment is operated.

- Ensure that all fluid line connectors are tight and all hoses are in good condition before applying pressure to the system.
- Since gasoline is highly flammable, handle it carefully.
  - Use an approved gasoline container.
  - Do not remove the cap from the fuel tank when the engine is hot or running.
  - Do not smoke while handling gasoline.
  - Fill the fuel tank outdoors, and fill it to about 25 mm (1 inch) below the top of the tank (the bottom of the filler neck). Do not overfill it.
  - Wipe up any spilled gasoline.

## While Operating

### **⚠ WARNING**

**Engine exhaust contains carbon monoxide, which is an odorless, deadly poison that can kill you.**

**Do not run engine indoors or in an enclosed area.**

- The operator should remain seated whenever the sprayer is in motion. The operator should keep both hands on the steering wheel whenever possible. Keep your arms and legs within the sprayer body at all times.
- Failure to operate the sprayer safely may result in an accident, tip over of the sprayer, and serious injury or death. Drive carefully. To prevent tipping or loss of control:
  - Use extreme caution, reduce speed, and maintain a safe distance around sand traps, ditches, creeks, ramps, unfamiliar areas, or any areas that have abrupt changes in ground conditions or elevation.
  - Watch for holes or other hidden hazards.
  - Use extra caution when operating the sprayer on wet surfaces, in adverse weather conditions, at higher speeds, or with a full load. Stopping time and distance will increase with a full load.
  - Avoid sudden stops and starts. Do not go from reverse to forward or forward to reverse without first coming to a complete stop.
  - Slow down before turning. Do not attempt sharp turns or abrupt maneuvers or other unsafe driving actions that may cause a loss of sprayer control.
  - Before backing up, look to the rear and ensure that no one is behind you. Back up slowly.

- Watch out for traffic when you are near or crossing roads. Always yield the right of way to pedestrians and other vehicles. This sprayer is **not** designed for use on streets or highways. Always signal your turns or stop early enough so that other people know what you plan to do. Obey all traffic rules and regulations.
- The electrical and exhaust systems of the sprayer can produce sparks capable of igniting explosive materials. Never operate the sprayer in or near an area where there is dust or fumes in the air which are explosive.
- If you are ever unsure about safe operation, **stop work** and ask your supervisor.
- Do not touch the engine or muffler while the engine is running or soon after it has stopped. These areas may be hot enough to cause burns.
- If the machine ever vibrates abnormally, stop immediately, wait for all motion to stop, and inspect the sprayer for damage. Repair all damage before resuming operation.
- Before getting off of the seat:
  1. Stop the movement of the machine.
  2. Place the range selector in Neutral and set the parking brake.
  3. Turn the ignition key to Off.
  4. Remove the ignition key.

**Important: Do not park the machine on an incline.**
- Lightning can cause severe injury or death. If lightning is seen or thunder is heard in the area, do not operate the machine; seek shelter.

## Braking

- Slow down before you approach an obstacle. This gives you extra time to stop or turn away. Hitting an obstacle can damage the sprayer and its contents. More important, it can injure you.
- Gross Vehicle Weight (GVW) has a major impact on your ability to stop and/or turn. Heavy loads and attachments make a sprayer harder to stop or turn. The heavier the load, the longer it takes to stop.
- Turf and pavement are much more slippery when they are wet. It can take 2 to 4 times as long to stop on wet surfaces as on dry surfaces. If you drive through standing water deep enough to get the brakes wet, they will not work well until they are dry. After driving through water, you should test the brakes to make sure they work properly. If they do not, drive slowly while putting light pressure on the brake pedal. This will dry the brakes out.

## ROPS Safety

**Note:** For each machine covered in this *Operator's Manual*, a cab installed by Toro is a ROPS.

- Do not remove the ROPS from the machine.
- Fasten the seat belt and ensure that you can release it quickly in an emergency. Always wear your seat belt when the roll bar is up or on a machine with a cab installed by Toro.
- Check carefully for overhead obstructions and do not contact them.
- Keep the ROPS in safe operating condition by thoroughly inspecting it periodically for damage and keeping all the mounting fasteners tight.
- Replace any damaged ROPS component. Do not repair or alter it.

## Operating on Hills and Rough Terrain

Operating the sprayer on a hill may cause tipping or rolling of the sprayer, or the engine may stall and you could lose headway on the hill. This could result in personal injury.

- Do not accelerate quickly or slam on the brakes when backing down a hill, especially with a load.
- Never drive across a steep hill; always drive straight up or down or go around the hill.
- If the engine stalls or you begin to lose headway while climbing a hill, gradually apply the brakes and slowly back straight down the hill.
- Turning while traveling up or down hills can be dangerous. If you have to turn while on a hill, do it slowly and cautiously. Never make sharp or fast turns.
- Heavy loads affect stability. Reduce the weight of the load and your speed when operating on hills.
- Avoid stopping on hills, especially with a load. Stopping while going down a hill will take longer than stopping on level ground. If the sprayer must be stopped, avoid sudden speed changes, which may initiate tipping or rolling of the sprayer. Do not slam on the brakes when rolling backward, as this may cause the sprayer to overturn.
- Reduce speed and load when operating on rough terrain, uneven ground, and near curbs, holes, and other sudden changes in terrain. Loads may shift, causing the sprayer to become unstable.

### **▲ WARNING**

**Sudden changes in terrain may cause abrupt steering wheel movement, possibly resulting in hand and arm injuries.**

- Reduce your speed when operating on rough terrain and near curbs.
- Grip the steering wheel loosely around the perimeter. Keep your hands clear of the steering wheel spokes.

## Loading

The weight of the cargo can change the sprayer center of gravity and sprayer handling. To avoid loss of control and personal injury, follow these guidelines:

- Reduce the weight of the load when operating on hills and rough terrain to avoid tipping or overturning of the sprayer.
- Liquid loads can shift. This shifting happens most often while turning, going up or down hills, suddenly changing speeds, or while driving over rough surfaces. Shifting loads can cause the sprayer to tip over.
- When operating with a heavy load, reduce your speed and allow for sufficient braking distance. Do not suddenly apply the brakes. Use extra caution on slopes.
- Be aware that heavy loads increase your stopping distance and reduce your ability to turn quickly without tipping over.

## Maintenance

- Only permit qualified and authorized personnel to maintain, repair, adjust, or inspect the sprayer.
- Before servicing or making adjustments to the machine, stop the engine, set the parking brake, and remove the key from the ignition to prevent someone from accidentally starting the engine.
- To make sure that the entire machine is in good condition, keep all nuts, bolts, and screws properly tightened.
- To reduce the potential for fire, keep the engine area free of excessive grease, grass, leaves, and accumulation of dirt.
- Never use an open flame to check the level or leakage of fuel or battery electrolyte.
- If the engine must be running to perform a maintenance adjustment, keep your hands, feet, clothing, and any parts of your body away from the engine and any moving parts. Keep everyone away.
- Do not use open pans of fuel or flammable cleaning fluids when cleaning parts.
- Do not adjust the ground speed governor. To ensure safety and accuracy, have an Authorized Toro Distributor check the ground speed.

- Keep your body and hands away from pin hole leaks or nozzles that eject high pressure fluid. Use cardboard or paper to find leaks. Fluid escaping under pressure can penetrate skin and cause injury requiring surgery within a few hours by a qualified surgeon; otherwise, gangrene may result.
- If major repairs are ever needed or assistance is required, contact an Authorized Toro Distributor.
- To be sure of optimum performance and safety, always purchase genuine Toro replacement parts and accessories. Replacement parts and accessories made by other manufacturers could be dangerous. Altering this sprayer in any manner that may affect sprayer operation, performance, durability, or its use, may result in injury or death. Such use could void the product warranty.

## Sound Power

This unit has a guaranteed sound power level of 96 dBA, which includes an Uncertainty Value (K) of 1 dBA.

Sound power level was determined according to the procedures outlined in ISO 11094.

## Sound Pressure

This unit has a sound pressure level at the operator's ear of 83 dBA, which includes an Uncertainty Value (K) of 1 dBA.

Sound pressure level was determined according to the procedures outlined in EN ISO 11201.

## Hand-Arm Vibration

Measured vibration level for right hand = 3.00 m/s<sup>2</sup>

Measured vibration level for left hand = 3.20 m/s<sup>2</sup>

Uncertainty Value (K) = 1.6 m/s<sup>2</sup>

Measured values were determined according to the procedures outlined in EN 1032.

## Whole Body Vibration

Measured vibration level = 0.58 m/s<sup>2</sup>

Uncertainty Value (K) = 0.29 m/s<sup>2</sup>

Measured values were determined according to the procedures outlined in EN 1032.

# Safety and Instructional Decals



Safety decals and instructions are easily visible to the operator and are located near any area of potential danger. Replace any decal that is damaged or lost.

## CALIFORNIA SPARK ARRESTER WARNING

Operation of this equipment may create sparks that can start fires around dry vegetation. A spark arrester may be required. The operator should contact local fire agencies for laws or regulations relating to fire prevention requirements.

117-2718

117-2718

decal117-2718



120-0622

120-0622

decal120-0622

1. Warning—read the *Operator's Manual*.
2. Warning—do not enter the sprayer tank.
3. Chemical burn hazard; toxic gas inhalation hazard—wear hand and skin protection; wear eye and respiratory protection.

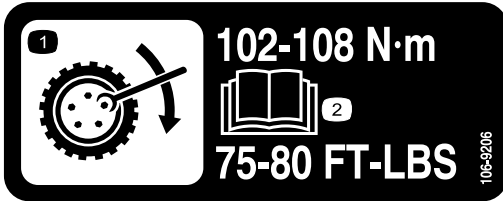

106-9206

106-9206

decal106-9206

1. Wheel torque specifications
2. Read the *Operator's Manual*.

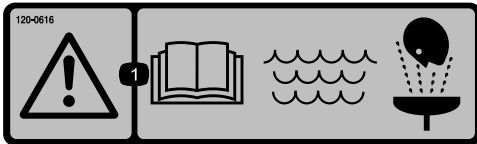

120-0616

120-0616

decal120-0616

1. Warning—read the *Operator's Manual*; use fresh, clean water for first-aid washing.



120-0617

120-0617

decal120-0617

1. Severing hazard of hand, pinching point—keep away from actuated joints.
2. Crushing hazard—keep bystanders away from the machine.

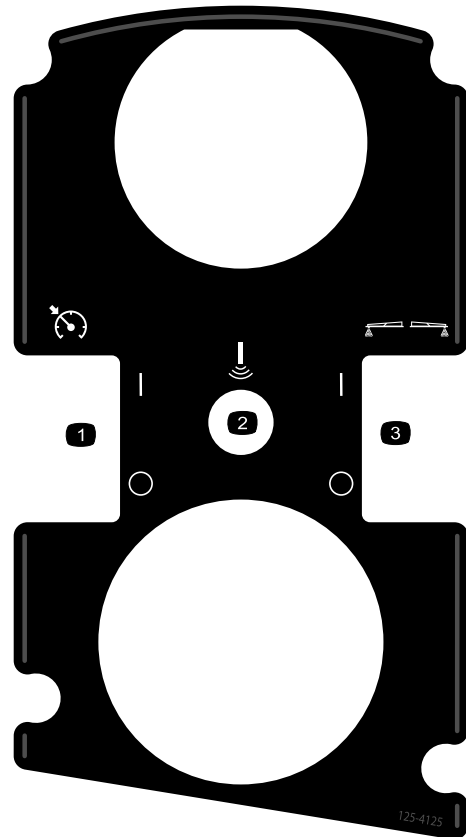

125-4125

125-4125

decal125-4125

1. Turn the throttle lock/speed lock on/off
2. Sonic boom (optional)
3. Turn the foam makers on/off (optional)



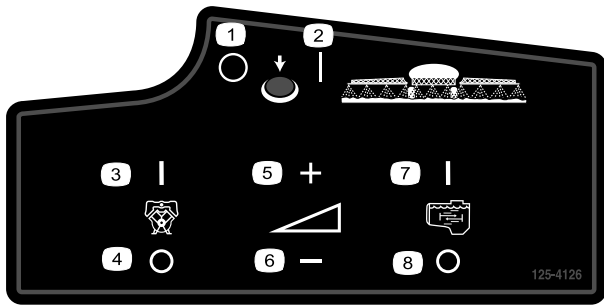

decal125-4126

**125-4126**

- |                         |                            |
|-------------------------|----------------------------|
| 1. Turn off master boom | 5. Increase spray pressure |
| 2. Turn on master boom  | 6. Decrease spray pressure |
| 3. Turn on pump         | 7. Turn on agitation       |
| 4. Turn off pump        | 8. Turn off agitation      |

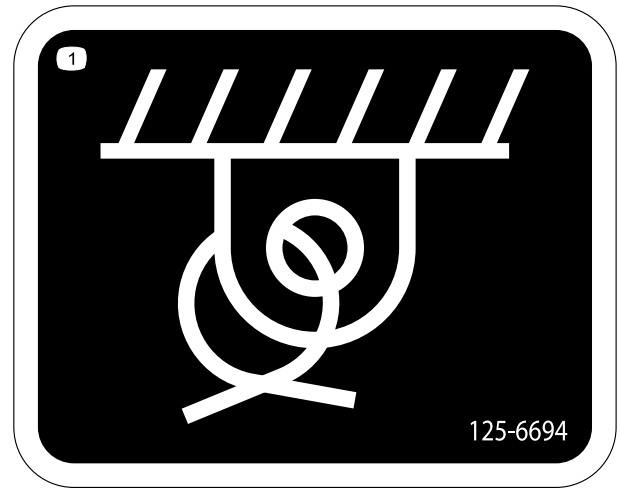

decal125-6694

**125-6694**

1. Tie down location

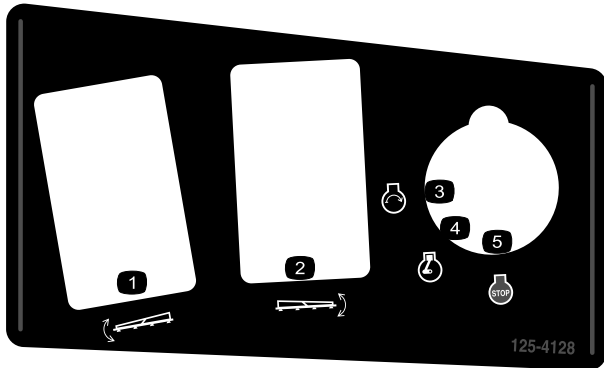

decal125-4128

**125-4128**

- |                           |                |
|---------------------------|----------------|
| 1. Raise/lower left boom  | 4. Engine—run  |
| 2. Raise/lower right boom | 5. Engine—stop |
| 3. Engine—start           |                |

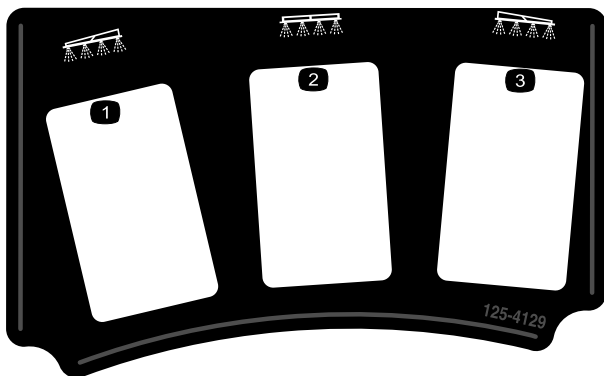

decal125-4129

**125-4129**

- |                |               |
|----------------|---------------|
| 1. Left boom   | 3. Right boom |
| 2. Center boom |               |

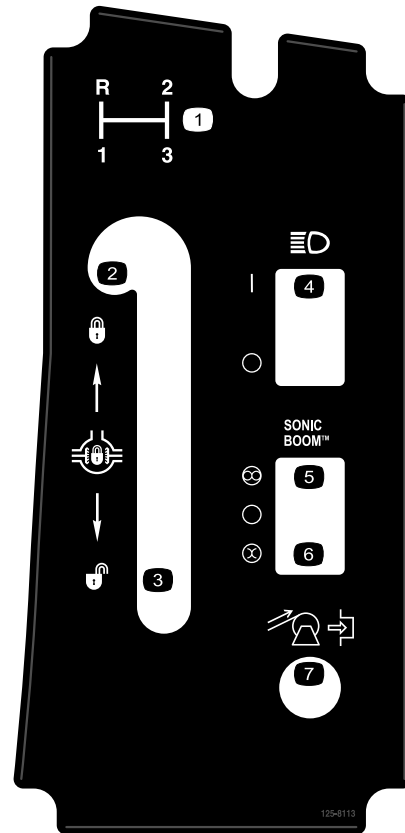

decal125-8113

**125-8113**

- |                             |                                |
|-----------------------------|--------------------------------|
| 1. Gear selection           | 5. Automatic (optional)        |
| 2. Lock differential lock   | 6. Manual (optional)           |
| 3. Unlock differential lock | 7. Rewind hose reel (optional) |
| 4. Toggle headlights on/off |                                |

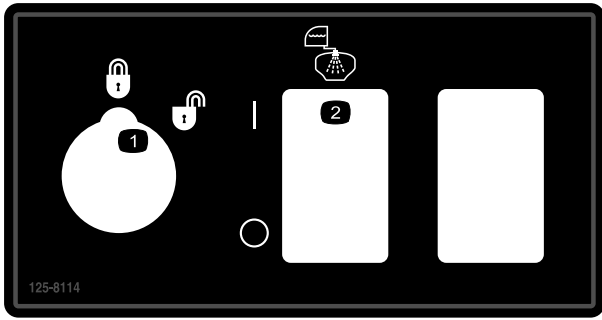

125-8114

decal125-8114

**125-8114**

1. Rate lockout locked/unlocked
2. Toggle rinse pump on/off

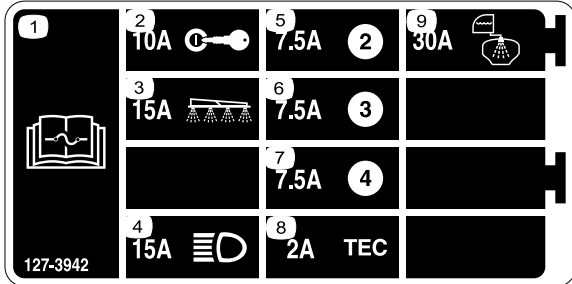

127-3942

decal127-3942

**127-3942**

1. Read the *Operator's Manual* for information on fuses.
2. 10A—Ignition
3. 15A—Sprayer boom
4. 15A—Headlights
5. 7.5A
6. 7.5A
7. 7.5A
8. 2A—TEC
9. 30A—Rinse tank

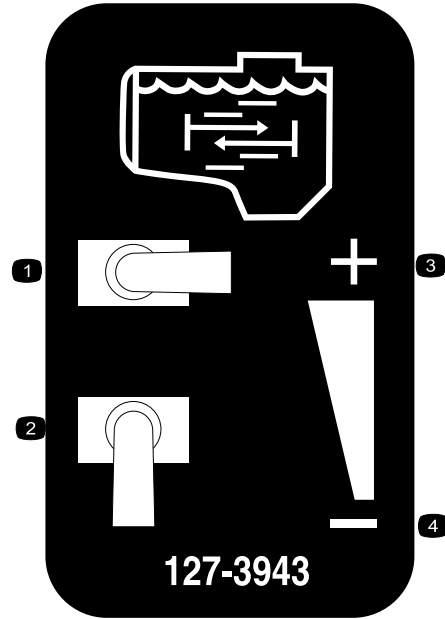

127-3943

decal127-3943

**127-3943**

1. Full agitation
2. No agitation
3. Increase agitation flow
4. Decrease agitation flow

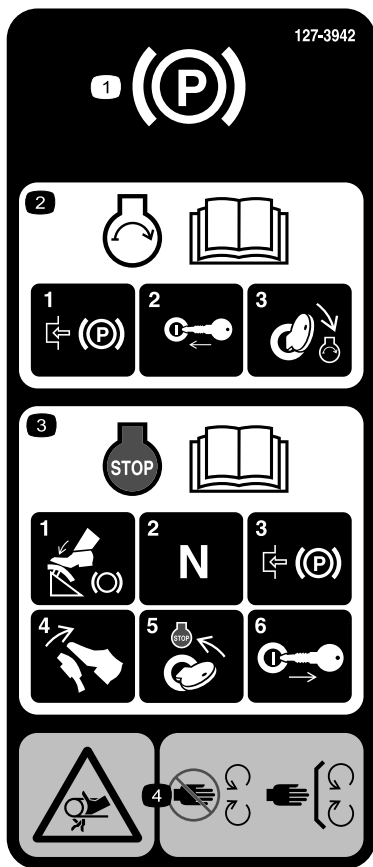

127-3935

decal127-3935

1. Parking brake
2. For information on starting the engine, read the *Operator's Manual*—1) Engage the parking brake; 2) Insert the key into the ignition; 3) Turn the key to the engine run position.
3. For information on stopping the engine, read the *Operator's Manual*—1) Press down on the brake pedal; 2) Set the gear to neutral; 3) Engage the parking brake; 4) Release the brake pedal; 5) Turn the ignition key to the engine stop position; 6) Remove the key from the ignition.
4. Entanglement hazard, belt—keep away from moving parts; keep all guards and shields in place.



127-3937

decal127-3937

1. Warning—do not step.
2. Warning—keep away from hot surfaces.
3. Entanglement hazard, belt—keep away from moving parts; keep all guards and shields in place.



decal127-3939

**127-3939**

- |  |  |
|--|--|
| <p>1. Warning—read the <i>Operator's Manual</i>; always wear a seat belt when operating the machine; do not tip the machine.</p> | <p>3. Cutting/dismemberment hazard—keep arms and legs inside the vehicle at all times.</p> |
| <p>2. Falling hazard—do not carry passengers on the sprayer tank.</p>  | <p>4. Warning—do not drill, weld, or alter the ROPS system.</p>                            |

# MULTIPRO 1750 QUICK REFERENCE AID

## CHECK/SERVICE

- |                            |                    |
|----------------------------|--------------------|
| 1. ENGINE OIL DIP STICK    | 9. FUEL FILL       |
| 2. ENGINE OIL FILL         | 10. FUEL FILTER    |
| 3. ENGINE OIL DRAIN        | 11. AIR FILTER     |
| 4. ENGINE OIL FILTER       | 12. BATTERY        |
| 5. TRANS/HYD OIL DIP STICK | 13. BRAKE FLUID    |
| 6. HYDRAULIC OIL FILTER    | 14. TIRE PRESSURE: |
| 7. HYDRAULIC OIL STRAINER  | - 20 PSI FRONT     |
| 8. TRANS/HYD OIL DRAIN     | - 20 PSI REAR      |
- GREASE POINTS (100 HRS)

## FLUID SPECIFICATIONS / CHANGE INTERVALS

SEE OPERATOR'S MANUAL FOR INITIAL CHANGES	FLUID TYPE	CAPACITY		CHANGE INTERVALS	
		L	QT	FLUID	FILTER
ENGINE OIL	SEE MANUAL	1.9	2	100 HRS.	100 HRS.
TRANS/HYDRAULIC OIL	DEXRON III ATF	7.1	7.5	800 HRS.	800 HRS.
FUEL	SEE MANUAL	18.9	5 GAL	--	400 HRS.
AIR CLEANER	CLEAN EVERY 50 HRS.				200 HRS.
TRANS AXLE STRAINER	--	--	--		CLEAN 800 HRS.

FOR HEAVY DUTY OPERATION, MAINTENANCE SHOULD BE PERFORMED TWICE AS FREQUENTLY.



THE TORO COMPANY  
8111 Lyndale Avenue South  
Bloomington, MN 55420-1196 USA

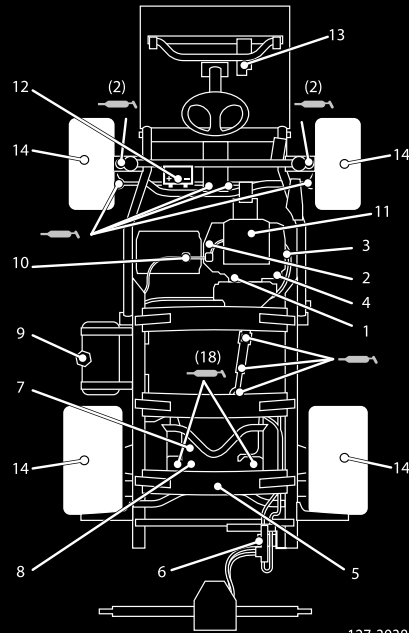

127-3938

127-3938

decal127-3938

1. Read the *Operator's Manual*.

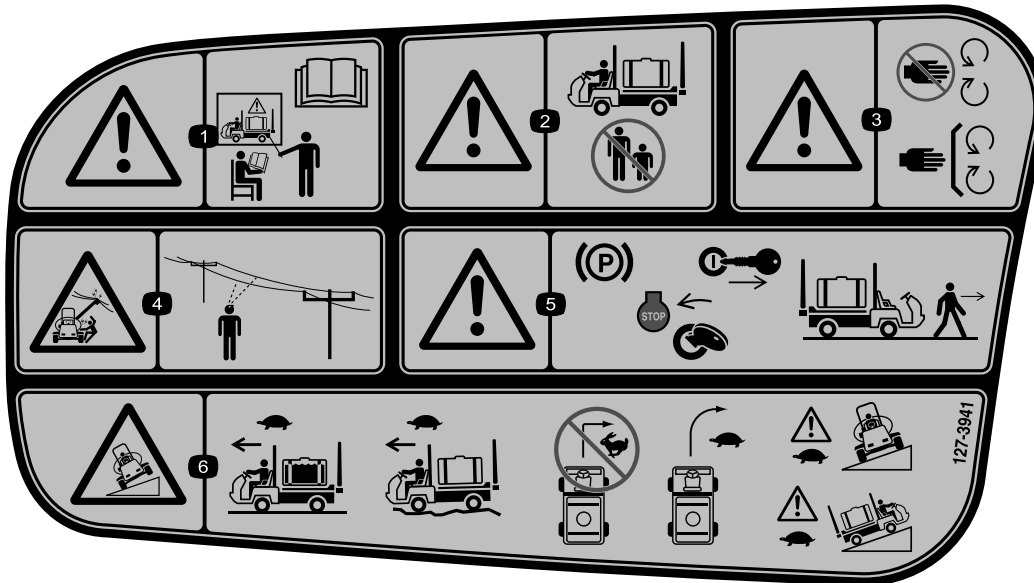

127-3941

decal127-3941

1. Warning—do not operate the machine without proper training; read the *Operator's Manual*.
2. Warning—keep bystanders away when operating the machine.
3. Warning—keep away from moving parts; keep all guards and shields in place.
4. Electrical shock hazard, overhead power lines—check the area for overhead power lines before operating the machine in the area.
5. Warning—Engage the parking brake, stop the engine, and remove the key from the ignition before leaving the machine.
6. Tipping hazard—Move slowly when the sprayer tank is full; move slowly when driving over rough terrain; do not turn at high speed; turn slowly; drive slowly when driving across or up slopes.

# Setup

## Loose Parts

Use the chart below to verify that all parts have been shipped.

Procedure	Description	Qty.	Use
<b>1</b>	90° fitting	1	Install the anti-siphon fill receptacle.
	Quick coupler	1	
	Hose adapter	1	
	Fill receptacle bracket	1	
	Flange-head bolt, 5/16 x 3/4 inch	1	
	Anti-siphon hose	1	
<b>2</b>	No parts required	–	Check the boom hinge springs.
<b>3</b>	Ignition key	1	Read the manuals and view the training material before operating the machine.
	Operator's Manual	1	
	Engine Operator's Manual	1	
	Parts Catalog	1	
	Operator Training Material	1	
	Registration Card	1	
	Pre-delivery Inspection Sheet	1	

**Note:** Determine the left and right sides of the machine from the normal operating position.

# 1

## Installing the Anti-siphon Fill Receptacle

Parts needed for this procedure:

1	90° fitting
1	Quick coupler
1	Hose adapter
1	Fill receptacle bracket
1	Flange-head bolt, 5/16 x 3/4 inch
1	Anti-siphon hose

### Procedure

- Place the fill receptacle bracket over the threaded hole in the tank and secure it with a flange-head bolt (5/16 x 3/4 inch) (Figure 3).

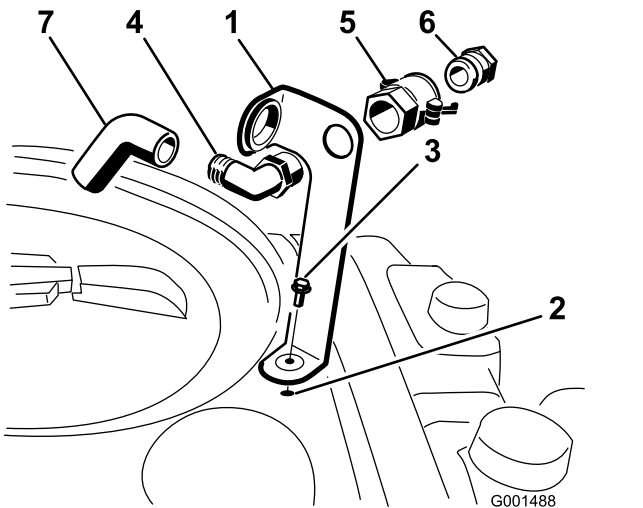

Figure 3

- |                                 |                     |
|---------------------------------|---------------------|
| 1. Fill receptacle bracket      | 5. Quick coupler    |
| 2. Threaded hole in the tank    | 6. Hose adapter     |
| 3. Flange bolt, 5/16 x 3/4 inch | 7. Anti-siphon hose |
| 4. 90° elbow fitting            |                     |

- Place the threaded end of the 90° elbow fitting through the bracket and thread the quick coupler onto it, securing it to the bracket (Figure 3).

**Note:** Install the fitting with the open end pointing toward the large opening in the bracket and toward the tank opening so the water will arc into the tank when you fill it.

- Install the hose adapter into the quick coupler (Figure 3).

- Lock the adapter into place by swinging the levers toward the adapter and then secure them with the hairpin cotters (Figure 3).
- Install the anti-siphon hose through the large opening on the bracket and onto the barbed end of the 90° elbow fitting (Figure 3).

**Important:** Do not lengthen the hose to allow contact with the tank fluids.

# 2

## Checking the Boom Hinge Springs

No Parts Required

### Procedure

**Important:** Operating the spray system with the boom hinge springs under the incorrect compression could damage the boom assembly. Measure the springs and use the jam nut to compress the springs to 4 cm (1-1/2 inches) if necessary.

The sprayer is shipped with the boom extensions swung forward to facilitate packaging of the machine. The springs are not fully tightened at the time of manufacture to allow the booms to be in this position for transit. Before operating the machine, the springs must be adjusted to the correct compression.

- If necessary, remove the packing components that secure the right and left extension booms during shipping.
- Support the booms while they are extended to the spray position.
- At the boom hinge, measure the compression of the upper and lower springs while the booms are in their extended position (Figure 4).
  - All springs must be compressed until they measure 4 cm (1-1/2 inches).
  - Use the jam nut to compress any spring that measure greater than 4 cm (1-1/2 inches).

# 3

## Learning More About Your Product

### Parts needed for this procedure:

1	Ignition key
1	<i>Operator's Manual</i>
1	<i>Engine Operator's Manual</i>
1	<i>Parts Catalog</i>
1	Operator Training Material
1	Registration Card
1	Pre-delivery Inspection Sheet

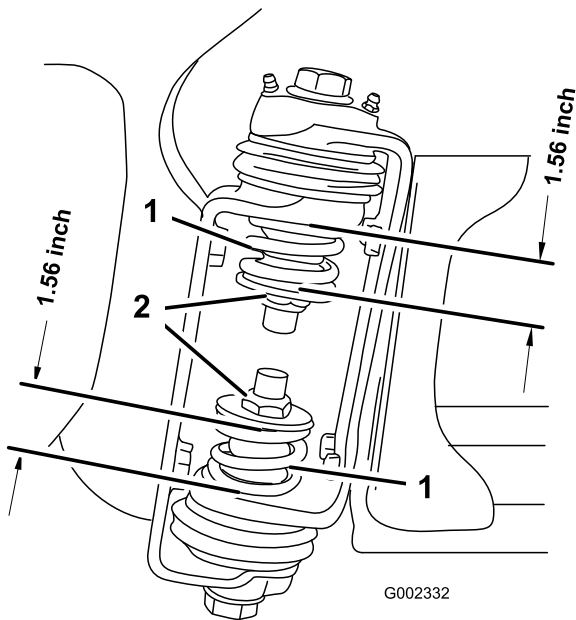

**Figure 4**

G002332

1. Boom hinge spring      2. Jam nut

4. Repeat the procedure for each spring on both boom hinges.
5. Move the booms into the transport "X" position. See [Using the Boom Transport Cradle \(page 28\)](#) for more information.

### Procedure

1. Read the manuals.
2. View the operator training material.
3. Complete the registration card and return it to Toro.
4. Store the documentation in a safe place.



# Product Overview

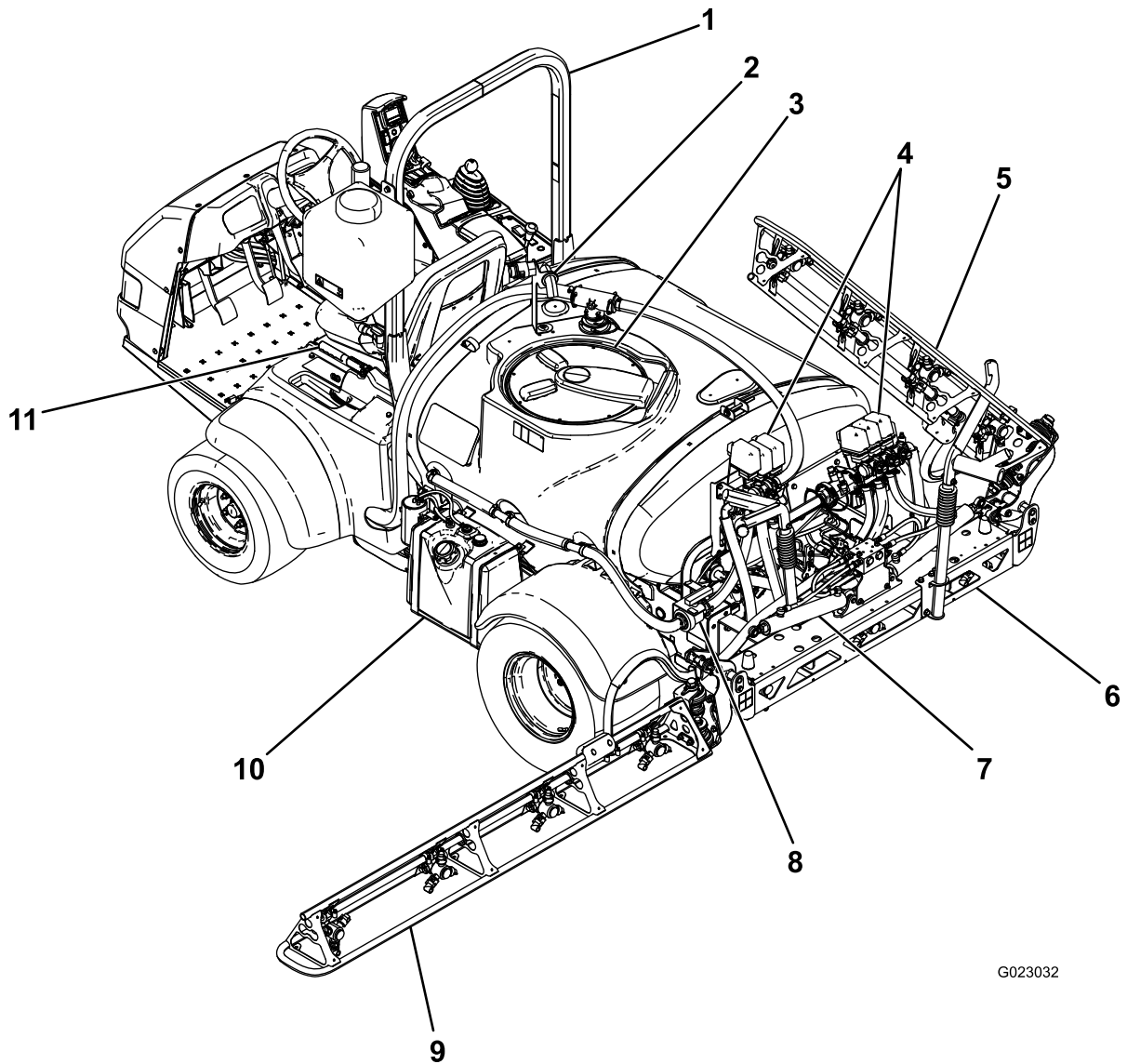

G023032

g023032

**Figure 5**

- |                           |                   |                             |                   |
|---------------------------|-------------------|-----------------------------|-------------------|
| 1. ROPS bar               | 4. Valve clusters | 7. Boom control cylinder    | 10. Fuel tank     |
| 2. Anti-siphon receptacle | 5. Right boom     | 8. Agitation throttle valve | 11. Parking brake |
| 3. Chemical tank lid      | 6. Center boom    | 9. Left boom                |                   |

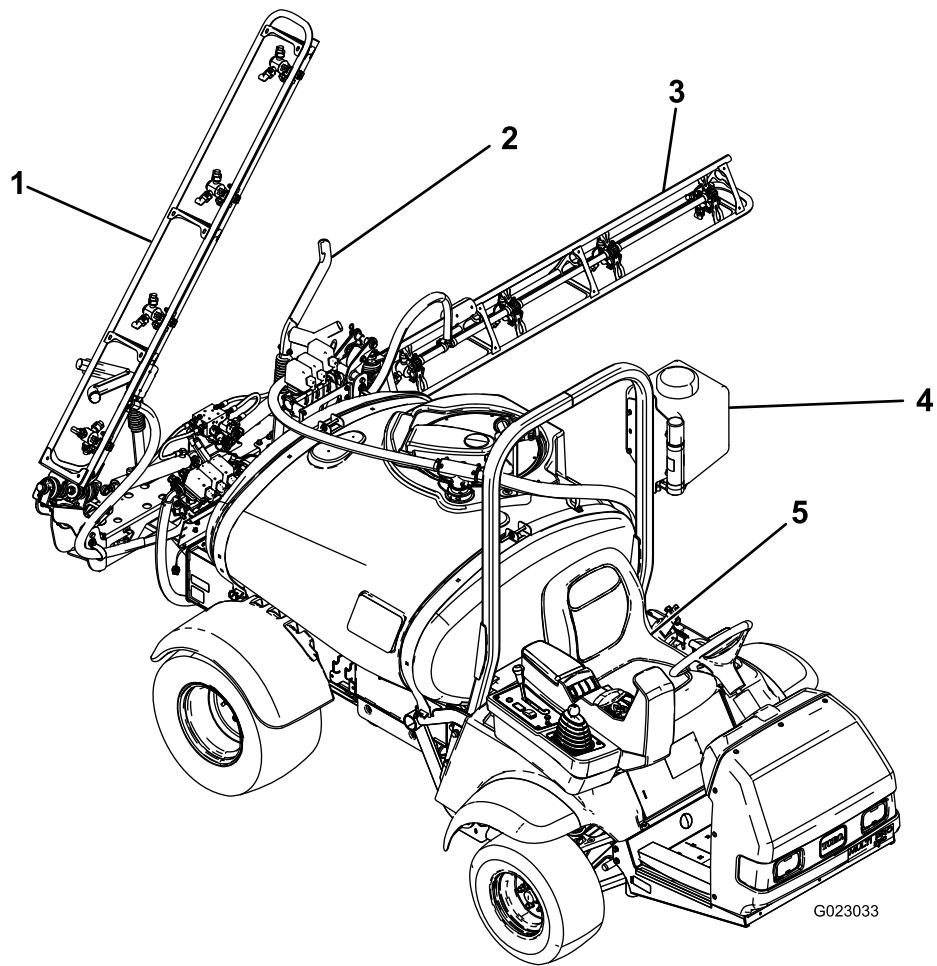

**Figure 6**

- 1. Right boom
- 2. Boom transport cradle
- 3. Left boom
- 4. Fresh water tank
- 5. Operator's seat

g023033

# Controls

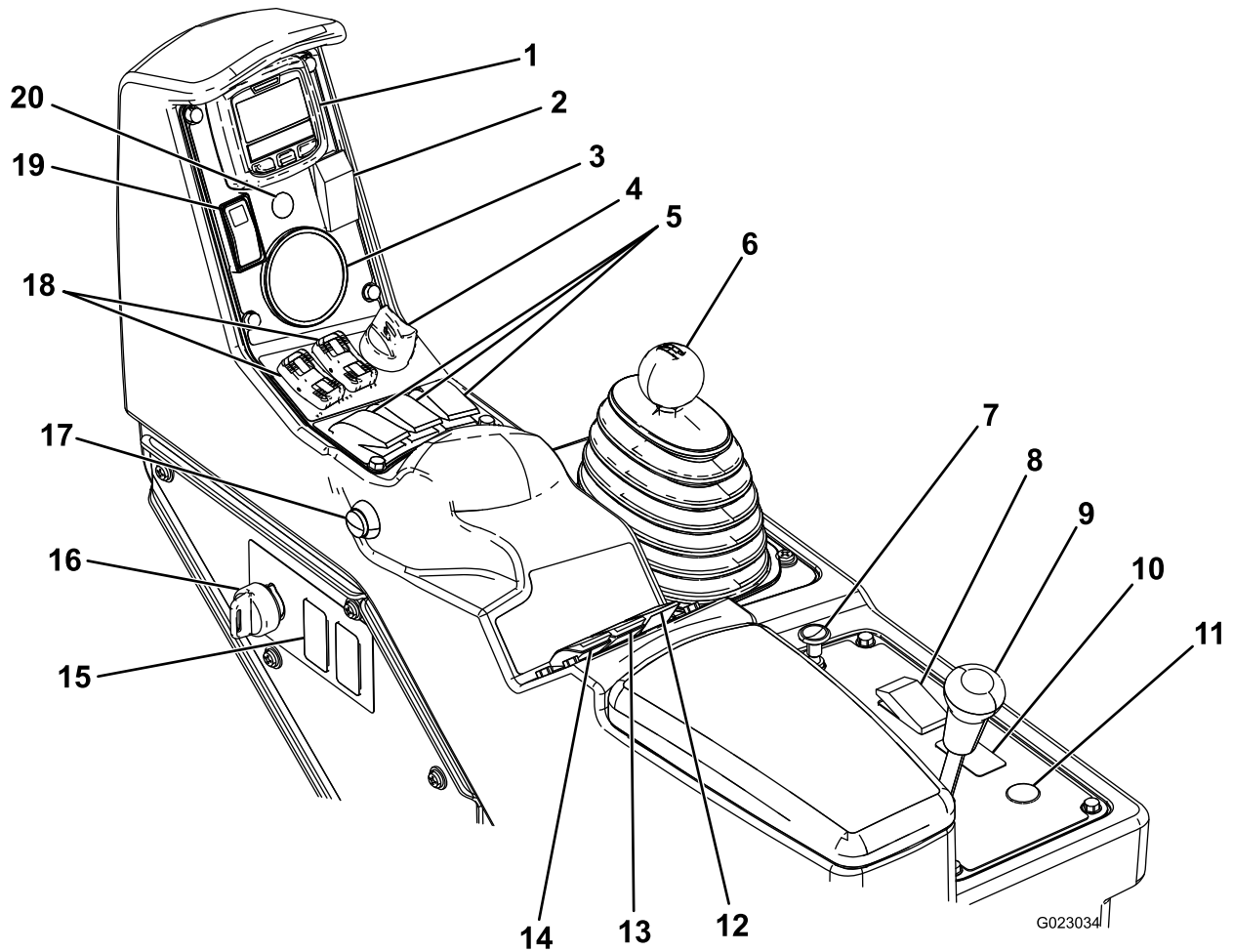

Figure 7

- |                                  |                                  |  |                                      |
|----------------------------------|----------------------------------|--|--------------------------------------|
| 1. InfoCenter                    | 6. Range selector                | 11. Hose reel rewind button (optional) | 16. Supervisor (rate lockout) switch |
| 2. Foam marker switch (optional) | 7. Choke                         | 12. Agitation switch                   | 17. Master boom switch               |
| 3. Pressure gauge                | 8. Headlight switch              | 13. Spray pressure switch              | 18. Boom lift switches               |
| 4. Engine switch                 | 9. Differential lock             | 14. Pump switch                        | 19. Throttle/speed lock switch       |
| 5. Boom switches                 | 10. Sonic boom switch (optional) | 15. Rinse tank switch (optional)       | 20. Sonic boom indicator (optional)  |

## Accelerator Pedal

The accelerator pedal (Figure 8) gives you the ability to vary the ground speed of the sprayer. Pressing the pedal increases ground speed. Releasing the pedal will slow the sprayer and the engine will idle.

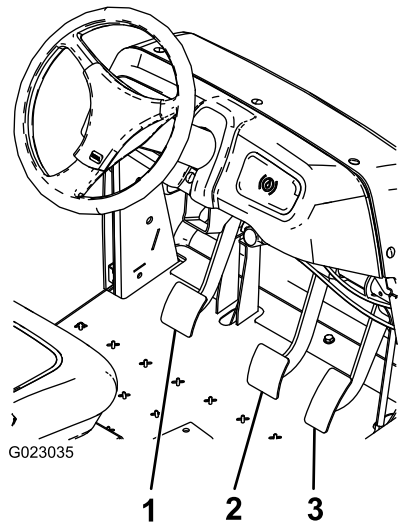

Figure 8

1. Clutch pedal
2. Brake pedal
3. Accelerator pedal

## Clutch Pedal

The clutch pedal (Figure 8) must be fully pressed to disengage clutch when starting the engine or shifting transmission gears. Release the pedal smoothly when the transmission is in gear to prevent unnecessary wear on the transmission and other related parts.

**Important:** Do not ride the clutch pedal during operation. The clutch pedal must be fully out or the clutch will slip causing heat and wear. Never hold the vehicle stopped on a hill using the clutch pedal. Damage to the clutch may occur.

## Brake Pedal

Use the brake pedal to stop or slow the sprayer (Figure 8).

### ⚠ CAUTION

Brakes can become worn or can be adjusted incorrectly resulting in personal injury.

If brake pedal travels to within 2.5 cm (1 inch) of the sprayer floor board, adjust or repair the brakes.

## Parking Brake

The parking brake is a large lever to the left of the seat (Figure 9). Engage the parking brake whenever you plan on leaving the seat to prevent accidental movement of the sprayer. To engage the parking brake, pull up and back on the lever. To disengage, push it forward and down. If the sprayer is parked on a steep grade, apply the parking brake and place blocks at the downhill side of the wheels.

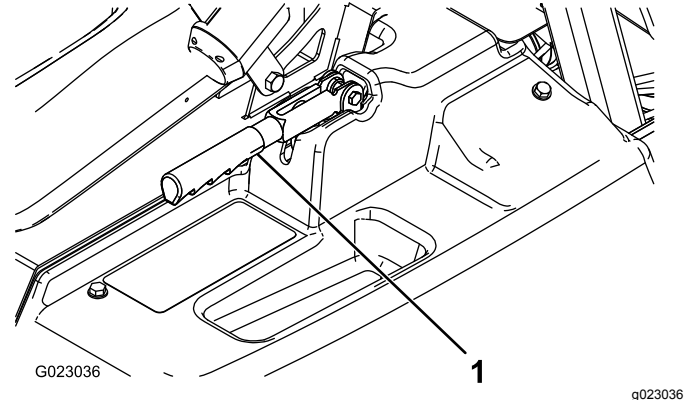

Figure 9

1. Parking brake lever

## Choke Control

The choke control is a small knob behind the range selector (Figure 7). To start a cold engine, pull the choke control up. After the engine starts, regulate the choke to keep the engine running smoothly. As soon as possible, push the control down to the Off position. A warm engine requires little or no choking.

## Range Selector

The range selector (Figure 7) has 5 positions: 3 forward speeds, Neutral, and Reverse. The engine will start only when the range selector is in the Neutral position.

## Ignition Switch

The ignition switch (Figure 7), used to start and stop the engine, has 3 positions: Stop, Run, and Start. Rotate the key clockwise to the Start position to start the engine and release it to the Run position when started. Rotate the key to the Stop position to stop the engine.

## Headlight Switch

Toggle the switch to operate the headlights (Figure 7). Push it forward to turn the lights on and rearward to turn them off.

## Throttle/Speed Lock Switch

When the range selector is in the Neutral position, you can use the accelerator pedal to speed up the engine, then push the switch below the InfoCenter forward to set the engine at that speed. This is necessary to run the chemical agitation while stationary or operating attachments such as the hand sprayer (Figure 7).

**Important:** The range selector must be in the Neutral position and the parking brake must be set for the switch to work.

## Fuel Gauge

The fuel gauge is located on top of the fuel tank, on the left side of the machine, and shows the amount of fuel in the tank.

## Master Boom Switch

The master boom switch (Figure 7) is located on the side of the console and to the right of the operator. It allows you to start or stop the spray operation. Press the switch to enable or disable the spray system.

## Boom Switches

The boom switches are located on the control panel (Figure 7). Toggle each switch forward to turn the corresponding boom section on and rearward to turn them off. When the switch is turned on, a light on the switch illuminates. These switches will only affect the spray system when the master boom switch is on.

## Pump Switch

The pump switch is located on the control panel to the right of the seat (Figure 7). Toggle this switch forward to run the pump or rearward to stop the pump.

**Important:** The pump switch will only engage when the engine is at low idle to avoid damaging the pump drive.

## Application Rate Switch

The application rate switch is located on the control panel to the right of the seat (Figure 7). Press and hold the switch forward to increase the spray system pressure, or press and hold it rearward to decrease pressure.

## Supervisor (Rate Lockout) Switch

The supervisor switch is located on the control panel to the right of the seat (Figure 7). Turn the key counterclockwise to the locked position to disable the application rate switch, thereby keeping anyone from

accidentally changing the application rate. Turn the key clockwise to the unlocked position to enable the application rate switch.

## Boom Lift

The boom lift switches are located on the control panel and are used to raise the left and right boom respectively.

## Hour Meter

The hour meter indicates the total number of hours the engine has run. This number is displayed on the first screen of the InfoCenter. The hour meter starts to function whenever the key is turned to the Run position.

## Sonic Boom (Optional)

The Sonic Boom switch is a rocker switch used to operate the Sonic Boom. Toggle the switch forward for automatic, rearward for manual and center for Off.

## Foam Marker Switch Locations (Optional)

If you install the Foam Marker kit, you will add switches to the control panel for controlling their operation. The sprayer comes with plastic plugs in these locations.

## Regulating (Rate Control) Valve

This valve, located behind the tank (Figure 10), controls the amount of fluid that is routed to the booms or the rate return to the tank.

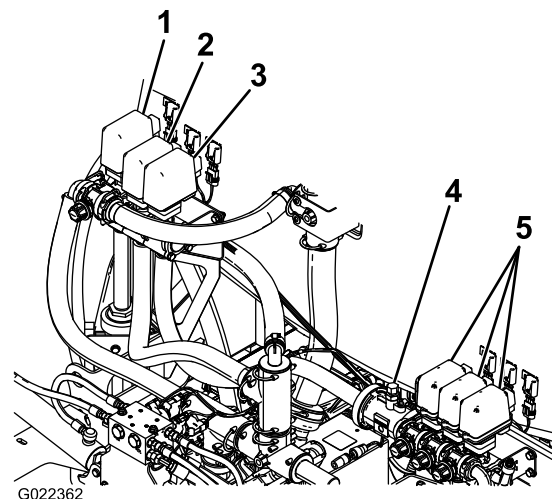

Figure 10

- |                                    |                |
|------------------------------------|----------------|
| 1. Agitation valve                 | 4. Flowmeter   |
| 2. Regulating (rate control) valve | 5. Boom valves |
| 3. Master boom valve               |                |

g022362

## Master Boom Valve

The master boom valve ([Figure 10](#)) is used to stop flow to the flowmeter and boom valves.

## Flowmeter

The flowmeter measures the flow rate of the fluid for use by the InfoCenter system ([Figure 10](#)).

## Boom Valves

These valves turn the three boom sections on or off ([Figure 10](#)).

## Boom Bypass

The boom bypass redirects the fluid flow for a boom section to the tank when you turn off the boom section. You can adjust the boom bypass to ensure that the boom pressure remains constant no matter how many booms sections are on. Refer to [Calibrating the Boom Bypass \(page 33\)](#).

## Agitation Valve

This valve is located on the rear of the tank ([Figure 10](#)). When agitation is on, the flow is directed through the agitation nozzles in the tank. When agitation is off, the flow is directed through the pump suction.

## Pressure Gauge

The pressure gauge is located on the control panel ([Figure 7](#)). This gauge shows the pressure of the fluid in the system in psi and kPa.

## InfoCenter LCD Display

The InfoCenter LCD display shows information about your machine and battery pack, such as the current battery charge, the speed, diagnostics information, and more ([Figure 7](#)).

For more information, refer to [Using the InfoCenter LCD Display \(page 30\)](#).

## Specifications

**Note:** Specifications and design are subject to change without notice.

Weight with standard spray system, empty, without operator	953 kg (2,100 lb)
Weight with standard spray system, full, without operator	1,678 kg (3,700 lb)
Maximum gross vehicle weight (GVW) (on level ground)	1,814 kg (4,000 lb)
Overall length with standard spray system	343 cm (135 inches)
Overall height with standard spray system	191 cm (75 inches)
Overall height with standard spray system to the top of the booms stored in the X position	246 cm (97 inches)
Overall width with standard spray system booms stored in the X position	178 cm (70 inches)
Ground clearance	14 cm (5.5 inches)
Wheel base	155 cm (61 inches)
Tank capacity (includes the CE 5% overflow)	662 L (175 US gallons)

## Attachments/Accessories

A selection of Toro approved attachments and accessories is available for use with the machine to enhance and expand its capabilities. Contact your Authorized Service Dealer or Distributor or go to [www.Toro.com](http://www.Toro.com) for a list of all approved attachments and accessories.

# Operation

**Note:** Determine the left and right sides of the machine from the normal operating position.

## Think Safety First

Please carefully read all of the safety instructions and decals in the safety section. Knowing this information could help you or bystanders avoid injury.

## Preparing to Drive the Sprayer for the First Time

### Checking the Engine Oil

The engine is shipped with oil in the crankcase; however, the level of oil must be checked before you first start the engine and after you have run it.

1. Position the machine on a level surface.
2. Remove the dipstick and wipe it with a clean rag (Figure 11).
3. Insert the dipstick into the tube and make sure it is seated fully. Remove the dipstick and check the oil level.

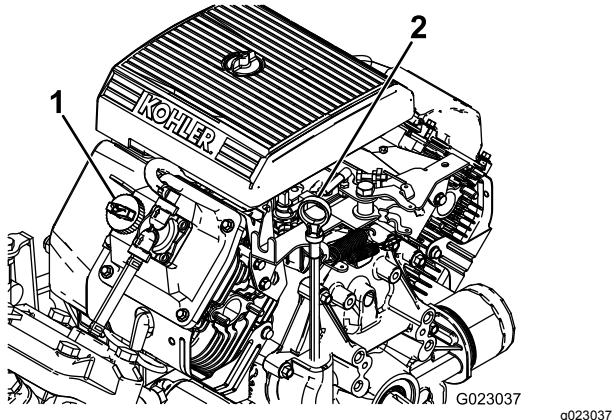

Figure 11

1. Filler cap                      2. Dipstick

4. If the oil level is low, remove the filler cap from the valve cover (Figure 11) and pour oil into the opening until the oil level is up to the Full mark on the dipstick; refer to [Servicing the Engine Oil \(page 41\)](#) for the proper oil type and viscosity. Add the oil slowly and check the level often during this process. Do not overfill.
5. Install the dipstick firmly in place.

## Checking the Tire Pressure

Check the tire pressure every 8 hours or daily to ensure proper levels. Fill the tires to 138 kPa (20 psi). Also, check the tires for wear or damage.

## Adding Fuel

### **⚠ DANGER**

In certain conditions, gasoline is extremely flammable and highly explosive. A fire or explosion from gasoline can burn you and others and can damage property.

- Fill the fuel tank outdoors, in an open area, when the engine is cold. Wipe up any gasoline that spills.
- Never fill the fuel tank inside an enclosed trailer.
- Do not fill the fuel tank completely full. Add gasoline to the fuel tank until the level is 6 to 13 mm (1/4 to 1/2 inch) below the bottom of the filler neck. This empty space in the tank allows gasoline to expand.
- Never smoke when handling gasoline, and stay away from an open flame or where gasoline fumes may be ignited by a spark.
- Store gasoline in an approved container and keep it out of the reach of children. Never buy more than a 30-day supply of gasoline.
- Do not operate without entire exhaust system in place and in proper working condition.



## ▲ DANGER

In certain conditions during fueling, static electricity can be released causing a spark which can ignite the gasoline vapors. A fire or explosion from gasoline can burn you and others and can damage property.

- Always place gasoline containers on the ground away from your vehicle before filling.
- Do not fill gasoline containers inside a vehicle or on a truck or trailer bed because interior carpets or plastic truck bed liners may insulate the container and slow the loss of any static charge.
- When practical, remove gas-powered equipment from the truck or trailer and refuel the equipment with its wheels on the ground.
- If this is not possible, then refuel such equipment on a truck or trailer from a portable container, rather than from a gasoline dispenser nozzle.
- If a gasoline dispenser nozzle must be used, keep the nozzle in contact with the rim of the fuel tank or container opening at all times until fueling is complete.

### Recommended Gasoline

Use fresh, clean, unleaded regular gasoline suitable for automotive use (87 pump octane minimum). Leaded gasoline may be used if unleaded regular is not available.

**Important:** Never use gasoline containing methanol, gasoline containing more than 10% ethanol, gasoline additives, or white gas because engine fuel system damage could result.

### Filling the Fuel Tank

The fuel tank capacity is approximately 19 L (5 US gallons).

**Note:** The fuel tank cap contains a gauge which shows the fuel level; check it frequently.

1. Shut the engine off and set the parking brake.
2. Clean the area around the fuel tank cap (Figure 12).

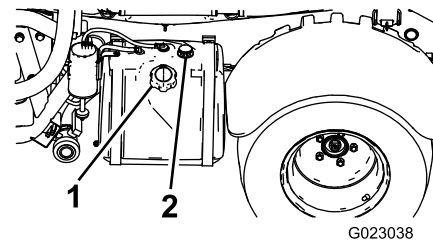

Figure 12

1. Fuel tank cap
2. Fuel gauge

3. Remove the fuel tank cap.
4. Fill the tank to about one inch below the top of the tank, (bottom of the filler neck). This space in the tank allows gasoline to expand. Do not overfill.
5. Install the fuel tank cap securely.
6. Wipe up any fuel that may have spilled.

## Pre-Starting Checks

Check the following items each time you begin using the sprayer for the day:

- Check the tire pressure.  
**Note:** These tires are different than car tires; they require less pressure to minimize turf compaction and damage.
- Check all fluid levels and add the appropriate amount of specified fluids, if any are found to be low.
- Check the brake pedal operation.
- Check to see that the lights are working.
- Turn the steering wheel to the left and right to check steering response.
- Check for oil leaks, loose parts, and any other noticeable malfunctions. Make sure the engine is off and all moving parts have stopped before checking for oil leaks, loose parts, and other malfunctions.

If any of the above items are not correct, notify your mechanic or check with your supervisor before taking the sprayer out for the day. Your supervisor may want you to check other items on a daily basis, so ask what your responsibilities are.



# Driving the Sprayer

## Starting the Engine

1. Sit in the operator's seat, insert the key into the ignition switch, and rotate the key clockwise to the Run position.
2. Press the clutch and move the range selector to the Neutral position.
3. Ensure that the pump switch is in the Off position.
4. If the engine is cold, pull the choke knob up.

**Important:** Do not use the choke if the engine is warm.

5. Turn the key to the Start position until the engine starts.

**Important:** Do not hold the key in the Start position for more than 10 seconds. If the engine has not started after 10 seconds, wait 1 minute before trying again. Do not attempt to push or tow the sprayer to start the engine.

6. Once the engine starts, push the choke knob down slowly.

## Driving

1. Release the parking brake.
2. Fully press the clutch pedal.
3. Move the gear shift lever to 1st gear.
4. Release the clutch pedal smoothly while pressing the accelerator pedal.
5. When the vehicle gains enough speed, remove your foot from the accelerator pedal, fully press the clutch pedal, move the gear shift lever to the next gear and release the clutch pedal while pressing the accelerator pedal. Repeat the procedure until the desired speed is attained.

**Important:** Always stop the vehicle before shifting from a forward gear to reverse or from reverse to a forward gear.

**Note:** Avoid long periods of engine idling.

Use the chart below to determine the ground speed of an empty vehicle at 3400 rpm.

Gear	Ratio	Speed (km/h)	Speed (mph)
1	66.4:1	5.6	3.5
2	38.1:1	9.8	6.1
3	19.6:1	19.2	11.9
R	80.7:1	4.7	2.9

**Note:** Leaving the ignition switch in the On position for long periods of time without running the engine will discharge the battery.

**Important:** Do not attempt to push or tow the vehicle to get it started. Damage to the drive train could result.

## Setting the Throttle Lock

**Note:** The parking brake and spray pump must be on and the range selector in neutral to set the throttle lock.

1. Press down on the accelerator pedal to obtain the desired engine rpm.
2. Toggle the throttle lock switch on the control panel to the On position.
3. To release the throttle lock, toggle the switch to the Off position, or press the brake or clutch pedal.

## Setting the Speed Lock

**Note:** Before setting the speed lock, the operator must be sitting in the operator's seat with the parking brake off, the pump on, and the range selector in gear.

1. Press down on the accelerator pedal to obtain the desired speed.
2. Toggle the speed lock switch on the control panel to the On position.
3. To release the speed lock, toggle the switch to the Off position, or press the brake or clutch pedal.

## Stopping the Engine

1. Press the clutch and apply the brake to stop the sprayer.
2. Pull the parking brake lever up and back to set it.
3. Move the range selector out of gear into the Neutral position.
4. Turn the ignition key to the Stop position.
5. Remove the key from the switch to prevent accidental starting.

## Breaking in a New Sprayer

To provide proper performance and long sprayer life, follow these guidelines for the first 100 operating hours:

- Check the fluid and engine oil levels regularly and be alert for indications of overheating in any component of the sprayer.
- After starting a cold engine, let it warm up for about 15 seconds before accelerating.

- Avoid hard braking situations for the first several hours of new sprayer break-in operation. New brake linings may not be at optimum performance until several hours of use has caused the brakes to become burnished (broken in).
- Avoid racing the engine.
- Vary the sprayer speed during operation. Avoid fast starts and quick stops.
- Refer to the Maintenance section for any special low-hour checks.

## Adjusting the Booms to Level

The following procedure can be used to adjust the actuators on the center boom to keep the left and right booms at level.

1. Extend the booms to the spray position.
2. Remove the cotter pin from the pivot pin (Figure 13).

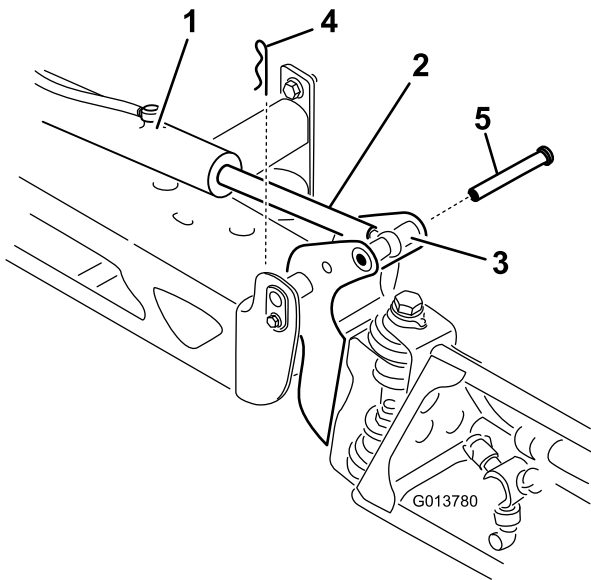
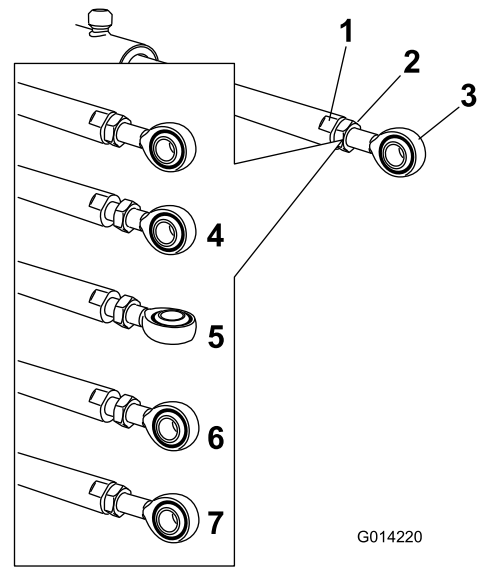

Figure 13

g013780

1. Actuator
2. Actuator rod
3. Boom pivot pin housing
4. Cotter
5. Pin

3. Lift up on the boom and remove the pin (Figure 13), and slowly lower the boom to the ground.
4. Inspect the pin for any damage, and replace it if necessary.
5. Use a wrench on the flat sides of the actuator rod to immobilize it, then loosen the jam nut to allow the eyelet rod to be manipulated (Figure 14).



G014220

g014220

Figure 14

1. Flat on the actuator rod
2. Jam nut
3. Eyelet
4. Jam nut loosened
5. Eyelet adjusted
6. Eyelet position for assembly
7. Jam nut tightened to lock new position

6. Turn the eyelet rod in the actuator rod to shorten or lengthen the extended actuator to the desired position (Figure 14).

**Note:** The eyelet rod must be turned in half or complete revolutions to allow the reassembly of the rod to the boom.

7. Once the desired position has been achieved, tighten the jam nut to secure the actuator and eyelet rod.
8. Raise the boom to align the pivot with the actuator rod. While holding the boom, insert the pin through both boom pivot and actuator rod (Figure 13).
9. With the pin in place, release the boom and secure the pin with the cotter previously removed.
10. Repeat the procedure for each actuator rod bearing, if necessary.

## Operating the Sprayer

To operate the Multi Pro Sprayer, first fill the spray tank, then apply the solution to the work area, and finally clean the tank. It is important that you complete all 3 of these steps in succession to avoid damaging the sprayer. For example, do not mix and add chemicals in the spray tank at night and then spray in the morning. This would lead to separation of the

chemicals and to possible damage to the sprayer components.

## **▲ CAUTION**

**Chemicals are hazardous and can cause personal injury.**

- **Read the directions on the chemical labels before handling the chemicals, and follow all manufacturer recommendations and precautions.**
- **Keep chemicals away from your skin. Should contact occur, wash the affected area thoroughly with soap and clean water.**
- **Wear goggles and any other protective equipment recommended by the chemical manufacturer.**

The Multi Pro Sprayer has been specifically designed to have high durability in order to give it the long sprayer life you need. Different materials have been chosen for specific reasons at different locations on your sprayer to meet this goal. Unfortunately, there is no single material which is perfect for all foreseeable applications.

Some chemicals are more aggressive than others, and each chemical interacts differently with various materials. Some consistencies (e.g. wettable powders, charcoal) are more abrasive and lead to higher-than-normal wear rates. If a chemical is available in a formulation that would provide increased life to the sprayer, use this alternative formulation.

As always, remember to clean your sprayer thoroughly after all applications. This will do the most to ensure that your sprayer has a long and trouble free life.

## **Filling the Fresh Water Tank**

Always fill the fresh water tank with clean water before handling or mixing any chemicals.

The fresh water tank is located on the left side of the ROPS bar. It supplies a source of fresh water for you to wash chemicals off of your skin, eyes, or other surfaces in the case of accidental exposure.

To open the fresh water tank spigot, turn the lever on the spigot.

## **Filling the Spray Tank**

Install the Chemical Pre-Mix Kit for optimal mixing and exterior tank cleanliness.

**Important:** Ensure that the chemicals you will be using are compatible for use with Viton (see

the manufacturer's label; it should indicate if it is not compatible). Using a chemical that is not compatible with Viton will degrade the O-rings in the sprayer, causing leaks.

**Important:** Verify that the proper application rate has been set prior to filling the tank with chemicals.

1. Stop the sprayer on a level surface, move the range selector to the Neutral position, stop the engine, and set the parking brake.
2. Ensure that the tank drain valve is closed.
3. Determine the amount of water needed to mix the amount of chemical you need as prescribed by the chemical manufacturer.
4. Open the tank cover on the spray tank.

**Note:** The tank cover is located in the center of the top of the tank. To open it, turn the front half of the cover counterclockwise and swing it open. You can remove the strainer inside for cleaning. To seal the tank, close the cover and rotate the front half clockwise.

5. Add 3/4 of the required water to the spray tank using the anti-siphon fill receptacle.

**Important:** Always use fresh clean water in the spray tank. Do not pour concentrate into an empty tank.

6. Start the engine and set the pump switch to the On position.
7. Press the accelerator pedal to the floor and set the throttle lock to the On position.
8. Set the master boom switch to the Off position.
9. Turn the agitation valve to the On position.
10. Add the proper amount of chemical concentrate to the tank as directed by the chemical manufacturer.

**Important:** If you are using a wettable powder without full agitation, mix the powder with a small amount of water to form a slurry before adding it to the tank.

11. Add the remaining water to the tank.

# Operating the Booms

The boom lift switches on the sprayer control panel allows you to move the booms between transport position and spray position without leaving the operator's seat. It is recommended to change boom positions while the machine is stationary.

## Changing the Boom Position

1. Stop the sprayer on level ground.
2. Use the boom lift switches to lower the booms.  
**Note:** Wait until the booms reach the full, extended spray position.
3. When the booms need to be retracted, stop the sprayer on level ground.
4. Use the boom lift switches to raise the booms, until they have moved completely into boom transport cradle forming the "X" transport position and the boom cylinders are fully retracted.

**Important:** To prevent damage to the boom actuator cylinder, make sure that the actuators are fully retracted before transport.

## Using the Boom Transport Cradle

The sprayer is equipped with a boom transport cradle that has a unique safety feature. In the event of accidental boom contact with a low overhead object while in the transport position, the boom(s) can be pushed out of the transport cradles. If this occurs, the booms will come to rest in a near horizontal position to the rear of the vehicle. While the booms will not be damaged due to this movement, they should be immediately put back into the transport cradle.

**Important:** The booms can be damaged by transporting them in any position other than the "X" transport position using the boom transport cradle.

To put the booms back into the transport cradle, lower the boom(s) to the spray position, and then raise the boom(s) back into the transport position. Make sure that the boom cylinders are fully retracted to prevent actuator rod damage.

## Spraying

**Important:** To ensure that your solution remains well mixed, use the agitation feature whenever you have a solution in the tank. For agitation to work, the pump must be on and the engine must be running above an idle. If you stop the vehicle and need agitation on, place the range selector in the Neutral position, set the parking brake, press

the accelerator pedal to the floor, turn on the pump, and turn the neutral engine speed lock On.

**Note:** This procedure assumes that the pump is on from the [Filling the Spray Tank \(page 27\)](#) procedure.

1. Lower the booms into position.
2. With the master boom switch in the Off position, set the 3 boom switches to the On position.
3. Drive to the location where you will be spraying.
4. Set the master boom switch to the On position to begin spraying.

**Note:** The InfoCenter will show the booms with the spray on.

**Note:** When the tank is nearly empty, the agitation may cause foaming in the tank. To prevent this, turn the agitation valve off. Alternatively, you can use an anti-foaming agent in the tank.

5. Use the rate switch to adjust and set a target.
6. When finished spraying, set the master boom switch to the Off position to turn off all booms, then set the pump switch to the Off position.

## Spraying Tips

- Do not overlap areas that you have previously sprayed.
- Watch for plugged nozzles. Replace all worn or damaged nozzles.
- Use the master boom switch to stop the spray flow before stopping the sprayer. Once stopped, place the range selector in neutral and use the neutral engine speed lock to hold the engine speed up to keep the agitation running.
- You will obtain better results if the sprayer is moving when you turn the booms on.
- Watch for changes in the application rate that may indicate that your speed has changed beyond the range of the nozzles or there is a problem with the spray system.

## Cleaning the Sprayer

**Important:** You must always empty and clean the sprayer immediately after each use. Failure to do so may cause the chemicals to dry or thicken in the lines, clogging the pump and other components.

**Note:** Install the Tank Clean Rinse Kit for optimal tank cleaning.

1. Stop the sprayer, set the parking brake, place the range selector in the Neutral position, and

turn off the engine. The tank will drain to the left side of the machine.

2. Locate the tank drain valve on the left side of the machine ([Figure 15](#)).

**Note:** The valve is behind the fender bracket next to the fuel tank.

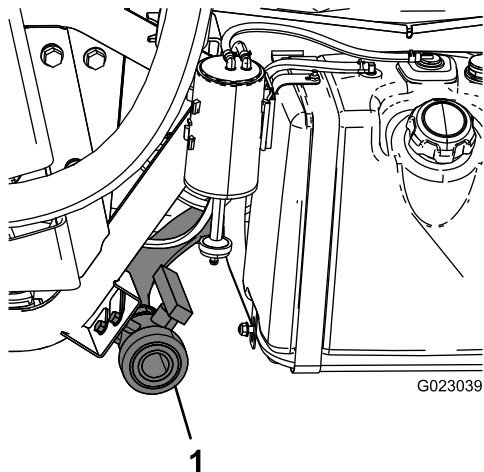

**Figure 15**

g023039

1. Tank drain

3. Remove the valve from the bracket, and let the valve rest on the ground.

4. Open the valve to drain any unused material from the tank and dispose of it according to local codes and the material manufacturer's instructions ([Figure 15](#)).

**Note:** This allows any residual material in the line to drain.

5. When the tank has drained completely, close the drain valve and install the valve onto the bracket ([Figure 15](#)).

6. Rinse the inside of the tank with at least 22 L (6 US gallons) of clean fresh water and close the cover.

**Note:** You can use a cleaning/neutralizing agent in the water as needed. On the final rinse, use only clean, clear water.

7. Start the engine.
8. Set the pump switch to the On position and use the application rate switch to increase the pressure to a high setting.
9. With the range selector in the Neutral position, press the accelerator pedal to the floor and toggle the throttle lock switch to the On position.
10. Ensure that the agitation valve is in the On position.
11. Set the master boom switch and boom control switches to the On position to begin spraying.

12. Allow all of the water in the tank to spray out through the nozzles.
13. Check the nozzles to ensure that they are all spraying correctly.
14. Set the master boom switch to the Off position, set the pump switch to the Off position, and stop the engine.
15. Repeat steps 6 through 14 at least 2 more times to ensure that the spray system is fully cleaned.
16. On the last cycle, run the last few gallons of water through the drain valve to clear the drain tubing.
17. Clean the strainer; refer to [Cleaning the Suction Strainer \(page 52\)](#).

**Important:** If you used wettable powder chemicals, clean the strainer after each tank.

18. Using a garden hose, spray off the outside of the sprayer with clean water.
19. Remove the nozzles and clean them by hand.

**Note:** Replace damaged or worn nozzles.

# Using the InfoCenter LCD Display

The InfoCenter LCD display shows information about your machine, such as the operating status, various diagnostics, and other information about the machine (Figure 16). There is a splash screen and main information screen on the InfoCenter. You can switch between the splash screen and main information screen at any time by pressing any of the InfoCenter buttons and then selecting the appropriate directional arrow.

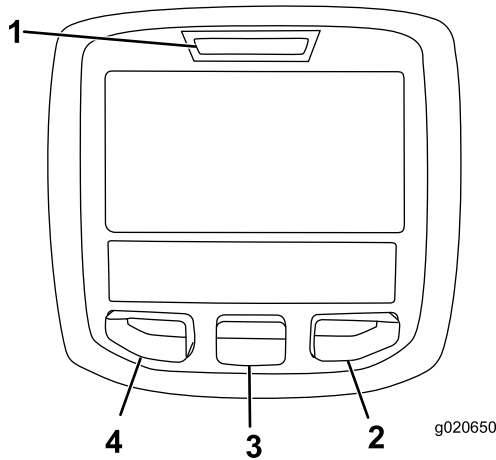

**Figure 16**















- |                    |                  |
|--------------------|------------------|
| 1. Indicator light | 3. Middle button |
| 2. Right button    | 4. Left button   |

- Left button, Menu access/Back button—press this button to access the InfoCenter menus. You can also use it to back out of any menu that you are currently using.
- Middle button—use this button to scroll down menus.
- Right button—use this button to open a menu where a right arrow indicated additional content.

**Note:** The purpose of each button may change depending on what is required at the time. Each button will have an icon displaying its current function.

# InfoCenter Icon Descriptions

	Parking brake active
	Information icon
	Hour meter
	Master boom On/Boom section Off
	Master boom On/Boom section On
	Empty spray tank
	Spray tank at half
	Full spray tank
	TURF units (1,000 square feet)
	Correct PIN code entered
	Hill-assist
	Area sprayed
	Volume sprayed
	Exit menu
	Go to the home screen
	Save value
	Next
	Previous
	Scroll down

	Enter
	Increase
	Decrease
	Adjust tank volume
	Throttle lock is active
	Home screen
	Inactive screen
	Active screen
	Active home screen
	Clear active area
	Clear all areas
	Change the next value in the list
	Adjust digit
	Check PIN entry/Calibration verification
	Select the next area for accumulation
	Tank level low

## Using the Menu

To access the InfoCenter menu system, press the menu access button while at the main screen. This will bring you to the main menu. Refer to the following tables for a synopsis of the options available from the menus:

Calibration	
Menu Item	Description
Test Speed	This menu sets the test speed for calibration.
Flow Calibration	This menu calibrates the flow meter.
Speed Calibration	This menu calibrates the speed sensor.

Settings Menu	
Menu Item	Description
Low Tank Alert	This menu sets the low tank volume alert.
Units	This menu changes the units used by the InfoCenter. The menu choices are English, SI (Metric), and Turf.
Language	This menu changes the language used on the InfoCenter.
LCD Backlight	This menu increases or decreases the brightness of the LCD display.
LCD Contrast	This menu changes the contrast between the dark and light areas of the LCD display.
Protected Menus	This menu grants access to protected menus.

Service Menu	
Menu Item	Description
Faults	This menu displays the most recent faults and last cleared fault.
Hours	This menu lists the total number of hours for key on, machine run, and pump on. It also lists the service due hour and service reset.

Diagnostics Menu	
Menu Item	Description
Pumps	This menu accesses the pump inputs, momentary rinse, and time rinse options.
Booms	This menu accesses the boom inputs, <u>qualifiers, and outputs.</u>
Throttle Lock	This menu accesses the throttle lock inputs, quantifiers, and outputs.
Engine Run	This menu accesses the engine run inputs and outputs.

About Menu	
Menu Item	Description
Model	This menu lists the model number of the machine.
Serial Number	This menu lists the serial number of the machine.
S/W Rev.	This menu lists the revision number of the machine software.

**Note:** If you inadvertently change the language or contrast to a setting where you can no longer understand or view the display, contact your Authorized Toro Distributor for assistance in resetting the display.

## Calibrating the Sprayer Flow

**Note:** Before using the sprayer for the first time, if you change the nozzles, or as needed, calibrate the sprayer flow, speed, and boom bypass.

1. Fill the spray tank with clean water.
2. Set the parking brake and turn the engine on.
3. Set the pump switch to the On position, and turn on the agitation.
4. Press down on the accelerator pedal until you reach the maximum engine speed, and toggle the throttle lock switch to the On position.
5. Set all 3 boom switches and the master boom switch to the On position.
6. Turn the supervisor (rate lockout) switch to the Unlock position.
7. Use the application rate switch to adjust the pressure as read on the pressure gauge until it is in the range for the nozzles you installed on the booms (typically 40 psi or 2.75 Bar).
8. Using a beaker, perform a catch test and adjust the application rate switch according to the table below.

**Note:** Repeat the test 3 times and use the average.

Nozzle Color	Milliliters collected in 15 seconds	Ounces collected in 15 seconds
Yellow	189	6.4
Red	378	12.8
Brown	473	16.0
Gray	567	19.2
White	757	25.6

Blue	946	32.0
Green	1,419	48.0

9. Turn the supervisor (rate lockout) switch to the Lock position.
10. Turn off the master boom switch.
 

**Note:** Ensure that there is enough water in the tank to complete the calibration.
11. On the InfoCenter, navigate to the Calibration menu and select Flow Calibration.
 

**Note:** Selecting the Home Screen icon at any time will cancel calibrations.
12. Using the plus (+) and minus (-) symbols, enter the flow volume according to the table below.

Nozzle Color	Liters	US Gallons
Yellow	42	11
Red	83	22
Brown	106	28
Gray	125	33
White	167	44
Blue	208	55
Green	314	83

13. Turn on the master boom switch for 5 minutes.
14. After 5 minutes, turn off the master boom switch and select the check mark on the InfoCenter.

**Note:** Calibration is now complete.

## Calibrating the Sprayer Speed

**Note:** Before using the sprayer for the first time, if you change the nozzles, or as needed, calibrate the sprayer flow, speed, and boom bypass.

1. On an open, flat area, mark off a distance between 45–152 m (150–500 ft).

**Note:** Toro recommends marking off 152 m (500 ft) for more accurate results.

2. Start the engine and drive to the start of the marked-off distance.

**Note:** Align the center of the front tires with the starting line for the most accurate measurement.

3. On the InfoCenter, navigate to the Calibration menu and select Speed Calibration.

**Note:** Selecting the Home Screen icon at any time will cancel calibrations.



- Fill the fresh water tank and select the Next arrow (→) on the InfoCenter.
- Fill the spray tank halfway with fresh water and select the Next arrow (→) on the InfoCenter.
- Using the plus (+) and minus (-) symbols, enter the marked off distance into the InfoCenter.
- Shift the machine into first gear and drive the marked distance in a straight line at full throttle.
- Stop the machine at the marked off distance and select the check mark on the InfoCenter.

**Note:** Slow down and roll to a stop to align the center of the front tires with the finish line, for the most accurate measurement.

**Note:** Calibration is now complete.

Gray	766 l/ha	51 gpa	1.17 gpk
White	1,019 l/ha	68 gpa	1.55 gpk
Blue	1,276 l/ha	85 gpa	1.94 gpk
Green	1,917 l/ha	127 gpa	2.91 gpk

- Turn off the left boom and adjust the boom bypass valve until the pressure reading is at the previously adjusted level (typically 40 psi or 2.75 Bar).

**Note:** The numbered indicators on the bypass valve are for reference only.

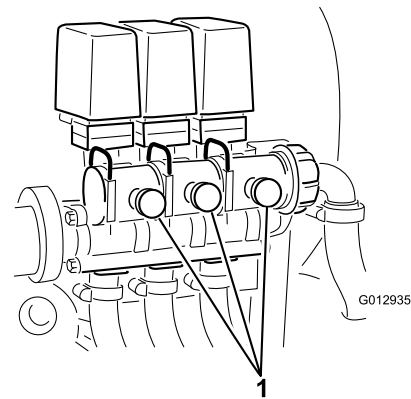

**Figure 17**

- Boom bypass adjustment

## Calibrating the Boom Bypass

**Note:** Before using the sprayer for the first time, if you change the nozzles, or as needed, calibrate the sprayer flow, speed, and boom bypass.

Select an open flat area to perform this procedure.

- Fill the spray tank halfway with clean water.
- Lower the sprayer booms.
- Move the range selector to the Neutral position, and set the parking brake.
- Set the 3 boom switches to the On position, but leave the master boom switch off.
- Set the pump switch to the On position, and turn on the agitation.
- Press down on the accelerator pedal until you reach the maximum engine speed, and toggle the throttle lock switch to the On position.
- On the InfoCenter, navigate to the Calibration menu and select Test Speed.

**Note:** Selecting the Home Screen icon at any time will cancel calibrations.

- Using the plus (+) and minus (-) symbols, enter a test speed of 3.5, then select the Home icon.
- Turn the supervisor (rate lockout) switch to the Unlock position, and turn the master boom switch on.
- Using the application rate switch, adjust the application rate according to the table below.

Nozzle Color	SI (Metric)	English	Turf
Yellow	237 l/ha	17 gpa	0.39 gpk
Red	509 l/ha	34 gpa	0.78 gpk
Brown	638 l/ha	42 gpa	0.97 gpk

- Turn on the left boom and turn off the right boom.
- Adjust the right boom bypass valve until the pressure reading is at the previously adjusted level (typically 40 psi or 2.75 Bar).
- Turn on the right boom and turn off the center boom.
- Adjust the center boom bypass valve until the pressure reading is at the previously adjusted level (typically 40 psi or 2.75 Bar).
- Turn all the booms off.
- Turn the pump off.

**Note:** Calibration is now complete.

## Calibrating the Agitation Bypass Valve

**Service Interval:** Yearly

Select an open flat area to perform this procedure.

- Fill the spray tank with clean water.
- Verify the agitation control valve is open. If it has been adjusted, open it completely at this time.
- Set the parking brake and start the engine.
- Set the range selector to Neutral.

5. Press the accelerator to the maximum engine rpm and use the hand throttle to hold it.

**Note:** If the hand throttle kit is not installed, an assistant will be required.

6. Pull the PTO to engage the pump and turn the agitation switch to the On position.
7. Use the application rate switch to adjust the pressure on the gauge reads 100 psi.
8. Turn the agitation switch to the Off position and read the pressure gauge.
  - If the reading remains at 100 psi the agitation bypass valve is properly calibrated.
  - If the pressure gauge reads differently continue to the next step.
9. Adjust the agitation bypass valve (Figure 18) on the backside of the agitation valve until the pressure reading on the gauge is 100 psi.

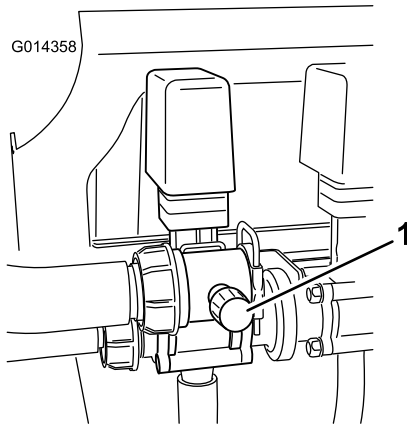

**Figure 18**

1. Agitation bypass valve

10. Turn the pump switch to the Off position. Shift the throttle lever to the Idle position and turn the ignition Off.

## Locating the Pump

The pump is located under the seat (Figure 19).

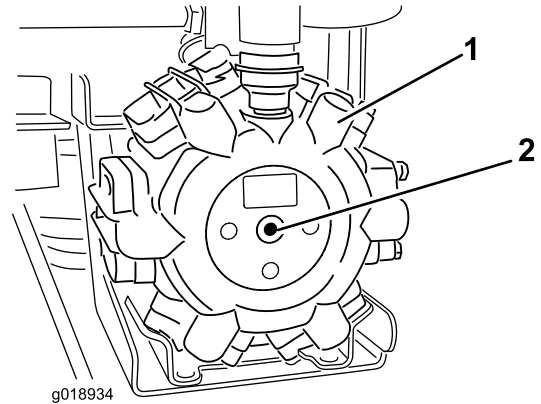

**Figure 19**

1. Pump
2. Grease fitting

## Towing the Sprayer

In case of an emergency, the sprayer can be towed for a short distance. However, we do not recommend this as a standard procedure.

### **⚠ WARNING**

**Towing at excessive speeds could cause a loss of steering control, resulting in personal injury.**

**Never tow the sprayer faster than 8 km/h (5 mph).**

Towing the sprayer is a 2-person job. If the machine must be moved a considerable distance, transport it on a truck or trailer; refer to [Transporting the Sprayer \(page 35\)](#).

1. Attach a tow line to the frame.
2. Put the range selector in the Neutral position and release the parking brake.
3. Tow the sprayer at less than 8 km/h (5 mph).

# Transporting the Sprayer

For moving the sprayer long distances, use a trailer. Secure the sprayer to the trailer. Also, make sure that the booms are tied down and secure. There is 1 metal loop on the front of the frame and 2 loops on the rear of the frame (Figure 20).

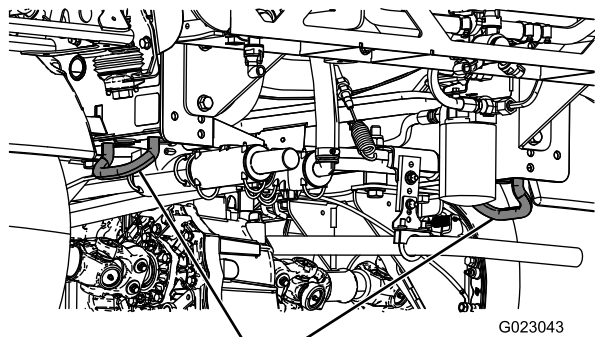
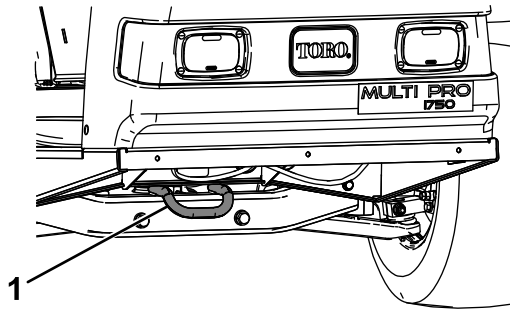

G023043

**2**  
**Figure 20**

g023043

1. Front tie-down point      2. Rear tie-down points

# Maintenance

**Note:** Determine the left and right sides of the machine from the normal operating position.

## Recommended Maintenance Schedule(s)

Maintenance Service Interval	Maintenance Procedure
After the first 8 hours	<ul style="list-style-type: none"> <li>• Torque the wheel lug nuts.</li> <li>• Replace the hydraulic filter.</li> </ul>
After the first 50 hours	<ul style="list-style-type: none"> <li>• Change the engine oil.</li> </ul>
Before each use or daily	<ul style="list-style-type: none"> <li>• Check the engine rotating screen.</li> <li>• Check the engine oil.</li> <li>• Check the tire pressure.</li> <li>• Clean the suction strainer (more often when using wettable powders).</li> </ul>
Every 25 hours	<ul style="list-style-type: none"> <li>• Clean and oil the air cleaner foam element (more often in dusty, dirty conditions).</li> </ul>
Every 50 hours	<ul style="list-style-type: none"> <li>• Lubricate the pump.</li> <li>• Check the battery cable connections.</li> <li>• Check the battery electrolyte level.</li> </ul>
Every 100 hours	<ul style="list-style-type: none"> <li>• Lubricate all grease fittings.</li> <li>• Lubricate the boom hinges.</li> <li>• Clean the engine rotating screen (more often in dusty, dirty conditions).</li> <li>• Replace the air cleaner paper element (more often in dusty, dirty conditions).</li> <li>• Change the engine oil (more often when operating under heavy load or in high temperature).</li> <li>• Replace the engine oil filter.</li> <li>• Replace the fuel filter.</li> <li>• Torque the wheel lug nuts.</li> <li>• Inspect the condition and wear of the tires.</li> <li>• Check front wheel toe-in.</li> <li>• Inspect the brakes.</li> </ul>
Every 200 hours	<ul style="list-style-type: none"> <li>• Change the spark plugs.</li> <li>• Check the parking brake.</li> <li>• Check the transaxle/hydraulic fluid.</li> <li>• Inspect all hoses and connections for damage and proper attachment.</li> <li>• Clean the flowmeter (more often when using wettable powders).</li> </ul>
Every 400 hours	<ul style="list-style-type: none"> <li>• Complete all yearly maintenance procedure specified in the engine operator's manual.</li> <li>• Inspect the fuel lines.</li> <li>• Drain and clean the fuel tank.</li> <li>• Inspect the pump diaphragms and replace if necessary (see an Authorized Toro Service Distributor).</li> <li>• Inspect the pump check valves and replace if necessary (see an Authorized Toro Service Distributor).</li> <li>• Inspect the center boom nylon pivot bushings.</li> </ul>
Every 800 hours	<ul style="list-style-type: none"> <li>• Change the transaxle/hydraulic fluid and clean strainer.</li> <li>• Replace the hydraulic filter.</li> </ul>
Yearly	<ul style="list-style-type: none"> <li>• Calibrate the agitation bypass valve.</li> </ul>

**Important:** Refer to your engine *Operator's Manual* for additional maintenance procedures.

# Daily Maintenance Checklist

Duplicate this page for routine use.

Maintenance Check Item	For the week of:						
	Mon.	Tues.	Wed.	Thurs.	Fri.	Sat.	Sun.
Check the brake and parking brake operation.							
Check the gear shift/neutral operation.							
Check the fuel level.							
Check the engine oil level.							
Check the transaxle oil level.							
Inspect the air filter.							
Inspect the engine cooling fins.							
Check any unusual engine noises.							
Check any unusual operating noises.							
Check the tire pressure.							
Check for fluid leaks.							
Check the instrument operation.							
Check the accelerator operation.							
Clean the suction strainer.							
Check toe-in.							
Lubricate all grease fittings. <sup>1</sup>							
Touch up and damaged paint.							

<sup>1</sup>Immediately after **every** washing, regardless of the interval listed

# Notation for Areas of Concern

Inspection performed by:		
Item	Date	Information
1		
2		
3		
4		
5		
6		
7		
8		
9		
10		
11		
12		

## ⚠ CAUTION

If you leave the key in the ignition switch, someone could accidentally start the engine and seriously injure you or other bystanders.

Remove the key from the ignition and disconnect the wire(s) from the spark plug(s) before you do any maintenance. Set the wire(s) aside so that it does not accidentally contact the spark plug(s).

### MULTIPRO 1750 QUICK REFERENCE AID

**CHECK/SERVICE**

1. ENGINE OIL DIP STICK
2. ENGINE OIL FILL
3. ENGINE OIL DRAIN
4. ENGINE OIL FILTER
5. TRANS/HYD OIL DIP STICK
6. HYDRAULIC OIL FILTER
7. HYDRAULIC OIL STRAINER
8. TRANS/HYD OIL DRAIN
9. FUEL FILL
10. FUEL FILTER
11. AIR FILTER
12. BATTERY
13. BRAKE FLUID
14. TIRE PRESSURE:  
-20 PSI FRONT  
-20 PSI REAR

☛ GREASE POINTS (100 HRS)

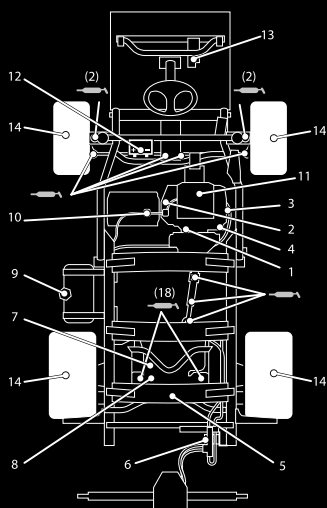

**FLUID SPECIFICATIONS / CHANGE INTERVALS**

SEE OPERATOR'S MANUAL FOR INITIAL CHANGES	FLUID TYPE	CAPACITY		CHANGE INTERVALS	
		L	QT	FLUID	FILTER
ENGINE OIL	SEE MANUAL	1.9	2	100 HRS.	100 HRS.
TRANS/HYDRAULIC OIL	DEXRON III ATF	7.1	7.5	800 HRS.	800 HRS.
FUEL	SEE MANUAL	18.9	5 GAL	---	400 HRS.
AIR CLEANER	CLEAN EVERY 50 HRS.			200 HRS.	
TRANS AXLE STRAINER	---	---	---	CLEAN 800 HRS.	

FOR HEAVY DUTY OPERATION, MAINTENANCE SHOULD BE PERFORMED TWICE AS FREQUENTLY.



THE TORO COMPANY  
8111 Lyndale Avenue South  
Bloomington, MN 55420-1196 USA

127-3938

Figure 21

decal127-3938

# Pre-Maintenance Procedures

## Jacking the Sprayer

Whenever the engine is run for routine maintenance and/or engine diagnostics, the rear wheels of the sprayer should be 2.5 cm (1 inch) off of the ground with the rear axle supported on jack stands.

### **⚠ DANGER**

**A sprayer on a jack may be unstable and slip off of the jack, injuring anyone beneath it.**

- **Do not start the engine while the sprayer is on a jack.**
- **Always remove the key from the ignition before getting off of the sprayer.**
- **Block the tires when the sprayer is on a jack.**

The jacking point at the front of the sprayer is under the front crossbar. The jacking point at the rear of the sprayer is on the rear frame support, behind the rear tie downs (Figure 22).

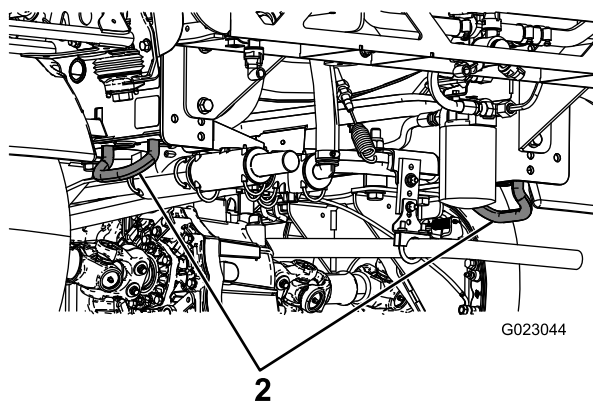
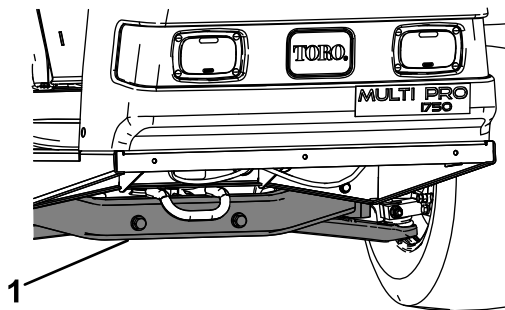

**Figure 22**

1. Front jacking point      2. Rear tie downs

# Lubrication

## Greasing the Sprayer

**Service Interval:** Every 50 hours—Lubricate the pump.

Every 100 hours/Yearly (whichever comes first)—Lubricate all grease fittings.

**Grease Type:** No. 2 General Purpose Lithium Base Grease

1. Wipe the grease fitting clean so that foreign matter cannot be forced into the bearing or bushing.
2. Pump grease into the bearing or bushing.
3. Wipe off excess grease.

See [Figure 21](#) for the location of all of the grease points.

## Greasing the Boom Hinges

**Service Interval:** Every 100 hours

**Important:** If the boom hinge is washed with water, all water and debris must be cleared from the hinge assembly and fresh grease must be applied.

**Grease Type:** No. 2 general-purpose lithium base grease.

1. Wipe the grease fittings clean so that foreign matter cannot be forced into the bearing or bushing.
2. Pump grease into the bearing or bushing at each fitting [Figure 23](#).

# Engine Maintenance

## Checking the Air Intake Screen

**Service Interval:** Before each use or daily—Check the engine rotating screen.

Every 100 hours—Clean the engine rotating screen (more often in dusty, dirty conditions).

Check and clean as necessary the air intake screen on the front of the engine before each use or daily.

## Servicing the Air Cleaner

**Service Interval:** Every 25 hours/Yearly (whichever comes first) (more often in dusty, dirty conditions).

Every 100 hours/Yearly (whichever comes first) (more often in dusty, dirty conditions).

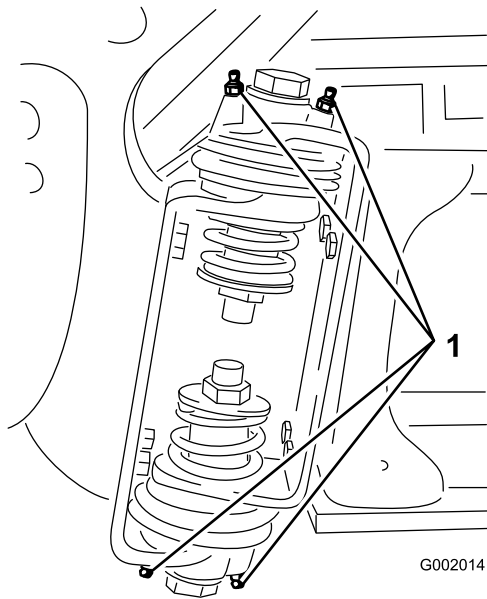

**Figure 23**

g002014

1. Grease fitting
2. Apply grease to the grease fitting.
3. Wipe off excess grease.
4. Repeat the procedure for each boom pivot.

## Removing the Foam and Paper Elements

1. Set the parking brake, stop the pump, stop the engine, and remove the ignition key.
2. Release the latch on the back of the seat and lift the seat forward.
3. Clean around the air cleaner to prevent dirt from getting into the engine and causing damage (Figure 24).

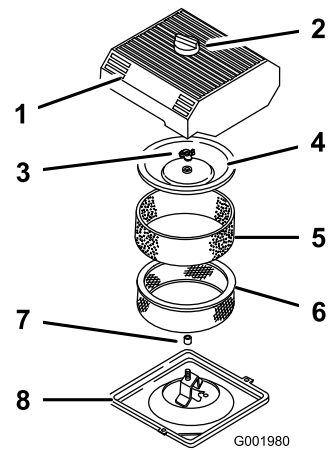

**Figure 24**

G001980

g001980

1. Air cleaner cover
2. Knob
3. Cover nut
4. Cover
5. Foam element
6. Paper element
7. Rubber seal
8. Air cleaner base

4. Loosen the knob on the air cleaner cover and remove the cover (Figure 24).



- Carefully slide the foam element off the paper element (Figure 24).
- Unscrew the cover nut and remove the cover and paper element (Figure 24).

## Cleaning the Foam Element

- Wash the foam element in liquid soap and warm water.
- When the element is clean, rinse it thoroughly.
- Dry the element by squeezing it in a clean cloth.
- Put 1 or 2 ounces of oil on the element (Figure 25).

**Important:** Replace the foam element if it is torn or worn.

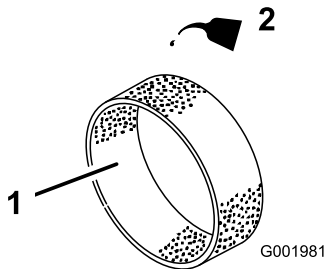

Figure 25

- Foam element
- Oil

- Squeeze the element to distribute the oil.

## Checking the Paper Element

Inspect the paper element for tears, an oily film, damage to the rubber seal, excessive dirt, or other damage (Figure 26). If any of these conditions exist, replace the filter.

**Important:** Do not clean the paper element with pressurized air or liquids, such as solvent, gas, or kerosene.

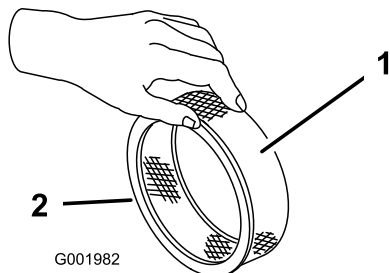

Figure 26

- Paper element
- Rubber seal

**Important:** To prevent engine damage, always operate the engine with the complete foam and paper air cleaner assembly installed.

## Installing the Foam and Paper Elements

- Carefully slide the foam element onto the paper air cleaner element (Figure 24).
- Slide the air cleaner assembly and cover onto the long rod.
- Install the cover nut finger-tight against the cover (Figure 24).

**Note:** Ensure that the rubber seal is flat against the air cleaner base and cover.

- Install the air cleaner cover and knob (Figure 24).
- Close and latch the seat.

## Servicing the Engine Oil

Crankcase Capacity is 2.0 l (2.1 qt) with the filter.

Use high-quality engine oil that meets the following specifications:

- API classification Level required: SJ, JK, SL, or higher.
- Preferred oil: SAE 10W30 (above 0° F)
- Alternate oil: SAE 5W30 (below 32° F)

Toro Premium Engine Oil is available from your distributor in either 10W30 or 5W30 viscosity. See the *Parts Catalog* for part numbers.

## Checking the Engine Oil

**Service Interval:** Before each use or daily

Every 400 hours/Yearly (whichever comes first)

The engine is shipped with oil in the crankcase; however, the level of oil must be checked before you first start the engine and after you have run it.

- Position the machine on a level surface.
- Remove the dipstick and wipe it with a clean rag (Figure 27). Insert the dipstick into the tube and make sure it is seated fully. Remove the dipstick and check the oil level.

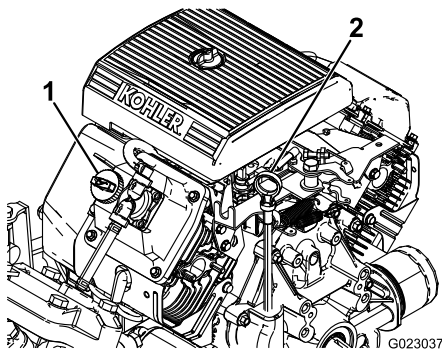

**Figure 27**

1. Filler cap                      2. Dipstick

3. If the oil level is low, remove the filler cap from the valve cover (Figure 27) and pour oil into the opening until the oil level is up to the Full mark on the dipstick. Add the oil slowly and check the level often during this process. Do not overfill.
4. Install the dipstick firmly in place.

## Changing the Engine Oil

**Service Interval:** After the first 50 hours—Change the engine oil.

Every 100 hours—Change the engine oil (more often when operating under heavy load or in high temperature).

1. Start the engine and let it run for five minutes. This warms the oil so it drains better.
2. Set the parking brake, stop the pump, stop the engine, and remove the ignition key.
3. Release the latch on the back of the seat and lift the seat forward.

### **CAUTION**

**Components under the seat will be hot if the sprayer has been running. If you touch hot components you may be burned.**

**Allow the sprayer to cool before performing maintenance or touching components under the hood.**

4. Place a pan below the oil drain.
5. Remove the drain plug (Figure 28).

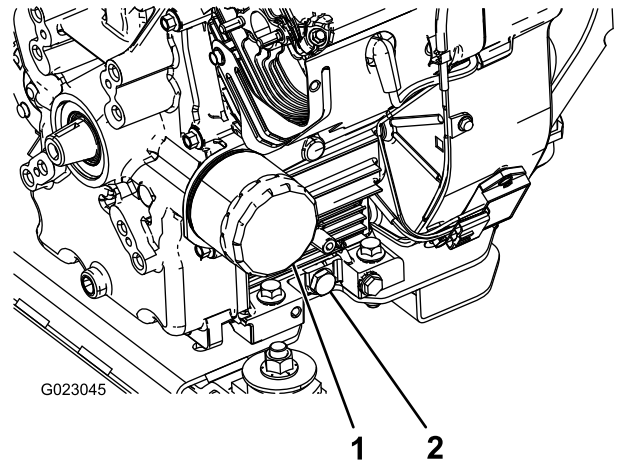

**Figure 28**

1. Oil filter                      2. Oil drain plug

6. When the oil has drained completely, replace the drain plug and torque it to 13.6 N-m (10 ft-lb).
7. Dispose of the used oil at a certified recycling center.
8. Slowly pour approximately 80% of the specified amount of oil into the oil filler tube (Figure 27).
9. Check the oil level.
10. Slowly add additional oil to bring the oil level to the full mark on the dipstick.

**Important:** Overfilling the crankcase with oil may cause engine damage.

## Changing the Engine Oil Filter

**Service Interval:** Every 100 hours

1. Drain the oil from the engine; refer to [Changing the Engine Oil \(page 42\)](#).
2. Remove the oil filter ([Figure 28](#)).
3. Wipe the filter adapter gasket surface.
4. Apply a thin coat of new oil to the rubber gasket on the replacement filter.
5. Install the replacement oil filter to the filter adapter. Turn the oil filter clockwise until the rubber gasket contacts the filter adapter, then tighten the filter an additional 1/2 turn ([Figure 28](#)).
6. Fill the crankcase with the correct type of new oil; refer to [Changing the Engine Oil \(page 42\)](#), steps 8 through 10.
7. Dispose of the used oil filter at a certified recycling center.

## Changing the Spark Plugs

**Service Interval:** Every 200 hours

**Type:** Champion RC-12YC (or equivalent)

**Air Gap:** 0.76 mm ( 0.030 inch)

Make sure the air gap between the center and side electrodes is correct before installing the spark plugs. Use a spark plug wrench for removing and installing the spark plugs and a gapping tool/feeler gauge to check and adjust the air gap.

### Removing the Spark Plug

1. Set the parking brake, stop the pump, stop the engine, and remove the ignition key.
2. Release the latch on the back of the seat and lift the seat forward.
3. Pull the wires off the spark plugs ([Figure 29](#)).
4. Clean around the spark plugs to prevent dirt from falling into the engine and potentially causing damage.
5. Remove the spark plugs and metal washers.

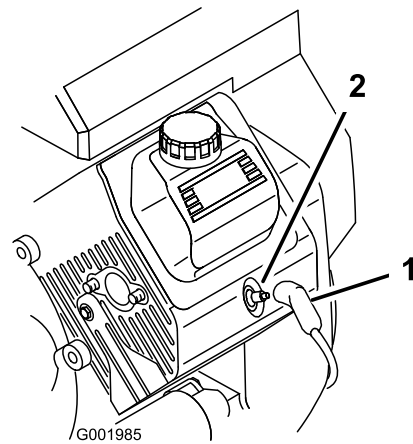

**Figure 29**

1. Spark plug wire
2. Spark plug

### Checking the Spark Plugs

1. Look at the center of the spark plugs ([Figure 30](#)).

If you see a light brown or gray coating on the insulator, the engine is operating properly. A black coating on the insulator usually means the air cleaner is dirty.

**Important:** Do not clean the spark plugs. Always replace a spark plug when it has a black coating, worn electrodes, an oily film, or cracks.

2. Check the gap between the center and side electrodes ([Figure 30](#)) and bend the side electrode, if the gap is not correct.

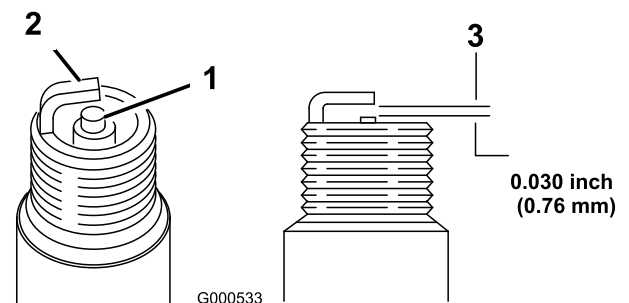

**Figure 30**

1. Center electrode insulator
2. Side electrode
3. Air gap (not to scale)

### Installing the Spark Plugs

1. Install the spark plugs and metal washers.
2. Tighten the spark plugs to 24.4 to 29.8 N-m (18 to 22 ft-lb).
3. Push the wires onto the spark plugs ([Figure 29](#)).
4. Close and latch the seat.

# Fuel System Maintenance

## Replacing the Fuel Filter

**Service Interval:** Every 100 hours—Replace the fuel filter.

Every 400 hours/Yearly (whichever comes first)—Inspect the fuel lines.

1. Set the parking brake, stop the pump, stop the engine, and remove the ignition key.
2. Release the latch on the back of the seat and lift the seat forward.
3. Clamp off the hose on either side of the fuel filter to prevent gas from pouring out of the hoses when you remove the filter.
4. Place a drain pan under the filter.
5. Squeeze the ends of the hose clamps together and slide them away from the filter (Figure 31).
6. Remove the filter from the fuel lines.

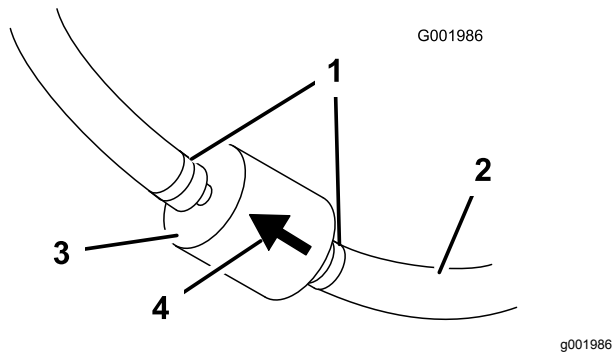

**Figure 31**

- |               |                         |
|---------------|-------------------------|
| 1. Hose clamp | 3. Filter               |
| 2. Fuel line  | 4. Flow direction arrow |

7. Install a new filter and move the hose clamps close to the filter.

Ensure that the flow direction arrow points toward the engine.

## Draining the Fuel Tank

**Service Interval:** Every 400 hours/Yearly (whichever comes first)

Drain and clean the fuel tank if the fuel system becomes contaminated or if you plan to store the machine for an extended period. Use fresh, clean fuel to flush out the tank.

1. Transfer the fuel from the tank into an approved fuel container using a siphon pump, or remove

the tank from the machine and pour the fuel out of the tank fill spout into the fuel container.

**Note:** If you remove the fuel tank, you will need to remove the fuel and return hoses from the tank before removing the tank.

2. Replace the fuel filter; refer to [Replacing the Fuel Filter \(page 44\)](#).
3. Flush the tank with fresh, clean fuel, if necessary.
4. Install the tank if you removed it.
5. Fill the tank with fresh, clean fuel.

# Electrical System Maintenance

## Locating the Fuses

There are 2 fuse blocks and 1 empty slot in the electrical system. They are located beneath the seat (Figure 32).

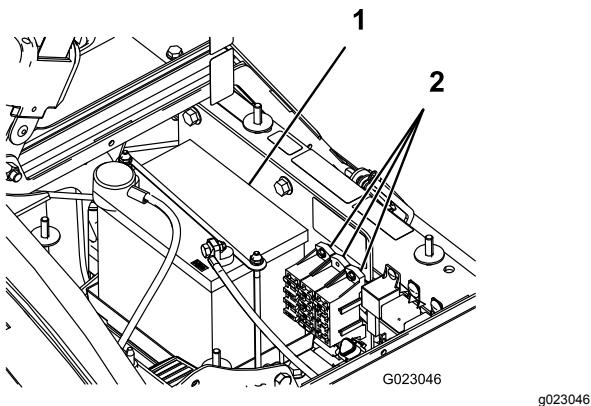

Figure 32

1. Battery

2. Fuse blocks

## Servicing the Battery

**Important:** Do not jump start the sprayer.

Always keep the battery clean and fully charged. Use a paper towel to clean the battery and battery box. If the battery terminals are corroded, clean them with a solution of four parts water and one part baking soda. Apply a light coating of grease to the battery terminals to prevent corrosion.

**Voltage:** 12 volt with 280 cold cranking Amps at 0° F

### Removing the Battery

1. Position the sprayer on a level surface, set the parking brake, stop the pump, stop the engine, and remove the ignition key.
2. The battery is located on the right hand side of the machine behind the pump (Figure 32).
3. Disconnect the negative (black) ground cable from the battery post.

### ▲ WARNING

Incorrect battery cable routing could damage the sprayer and cables causing sparks. Sparks can cause the battery gasses to explode, resulting in personal injury.

- Always disconnect the negative (black) battery cable before disconnecting the positive (red) cable.
- Always reconnect the positive (red) battery cable before reconnecting the negative (black) cable.

### ▲ WARNING

Battery terminals or metal tools could short against metal sprayer components causing sparks. Sparks can cause the battery gasses to explode, resulting in personal injury.

- When removing or installing the battery, do not allow the battery terminals to touch any metal parts of the sprayer.
- Do not allow metal tools to short between the battery terminals and metal parts of the sprayer.
- Always keep the battery strap in place to protect and secure the battery.

4. Disconnect the positive (red) cable from the battery post.
5. Remove the battery retainer and fasteners (Figure 32).
6. Remove the battery.

### Installing the Battery

**Service Interval:** Every 50 hours—Check the battery cable connections.

1. Set the battery on the battery box so that the battery posts are toward the front of the sprayer.
2. Install the battery retainer and secure it with the fasteners you removed previously (Figure 32).

**Important:** Always keep the battery retainer in place to protect and secure the battery.

3. Connect the positive (red) cable to the positive (+) battery post and the negative (black) cable to the negative (-) battery post using the bolts and wing nuts. Slide the rubber boot over the positive battery post.

4. Install the battery cover and secure it with the 2 knobs (Figure 32).
3. Connect a 3 to 4 amp battery charger to the battery posts. Charge the battery at a rate of 3 to 4 amperes for 4 to 8 hours (12 volts). Do not overcharge the battery.

## Checking the Electrolyte Level

**Service Interval:** Every 50 hours

**Note:** When the machine is in storage check the battery electrolyte level every 30 days.

1. Loosen the knobs on the sides of the battery box and remove the battery cover (Figure 32).
2. Remove the filler caps. If the electrolyte is not up to the fill line, add the required amount of distilled water; refer to [Adding Water to the Battery \(page 46\)](#).

### **⚠ DANGER**

**Battery electrolyte contains sulfuric acid which is a deadly poison and causes severe burns.**

- **Do not drink electrolyte or allow it to contact your skin, eyes or clothing. Wear safety glasses to shield your eyes and rubber gloves to protect your hands.**
- **Fill the battery where clean water is always available for flushing the skin.**

## Adding Water to the Battery

The best time to add distilled water to the battery is just before you operate the machine. This lets the water mix thoroughly with the electrolyte solution.

1. Clean the top of the battery with a paper towel.
2. Remove the filler caps from the battery and slowly fill each cell with distilled water until the level is up to the fill line. Replace the filler caps.

**Important:** Do not overfill the battery. Electrolyte will overflow onto other parts of the sprayer and severe corrosion and deterioration will result.

## Charging the Battery

**Important:** Always keep the battery fully charged (1.260 specific gravity). This is especially important to prevent battery damage when the temperature is below 0° C (32° F).

1. Remove the battery from the chassis; refer to [Removing the Battery \(page 45\)](#).
2. Check the electrolyte level; refer to [Checking the Electrolyte Level \(page 46\)](#).

### **⚠ WARNING**

**Charging the battery produces gasses that can explode.**

**Never smoke near the battery and keep sparks and flames away from battery.**

4. Install the battery in the chassis; refer to [Installing the Battery \(page 45\)](#).

## Storing the Battery

If the machine will be stored for more than 30 days, remove the battery and charge it fully. Either store it on the shelf or on the machine. Leave the cables disconnected if it is stored on the machine. Store the battery in a cool atmosphere to avoid quick deterioration of the charge in the battery. To prevent the battery from freezing, make sure it is fully charged.



# Drive System Maintenance

## Inspecting the Wheels and Tires

**Service Interval:** Before each use or daily—Check the tire pressure.

After the first 8 hours—Torque the wheel lug nuts.

Every 100 hours—Torque the wheel lug nuts.

Every 100 hours—Inspect the condition and wear of the tires.

Check the tire pressure every 8 hours or daily to ensure proper levels. Fill the tires to 138 kPa (20 psi). Also, check the tires for wear or damage.

Check the wheels to ensure that they are mounted securely after the first 8 operating hours and then every 100 hours thereafter. Torque the front and rear lug nuts to 102-108 N-m (75-80 ft-lb).

Check the tire condition at least every 100 hours of operation. Operating accidents, such as hitting curbs, can damage a tire or rim and also disrupt wheel alignment, so inspect tire condition after an accident.

## Adjusting the Front Wheel Toe-in

**Service Interval:** Every 100 hours/Yearly (whichever comes first)

The toe-in should be 0 to 6 mm (0 to 1/4 inch).

1. Fill the tank with approximately 331 L (87.5 US gallons) of water.
2. Check and fill all tires; refer to [Checking the Tire Pressure \(page 23\)](#).
3. Drive the sprayer back and forth a few times to relax the A-arms, then drive it forward at least 3 m (10 ft).
4. Measure the distance between both of the front tires at the axle height at both the front and rear of the front tires ([Figure 33](#)).

**Note:** A fixture or alignment gauge is needed for the rear measurement of the front tires at axle height. Use the same fixture or alignment gauge to accurately measure the front of the front tires at axle height ([Figure 33](#)).

The front of the tires should be 0 to 6 mm (0 to 1/4 inch) closer than the back side of the front tires.

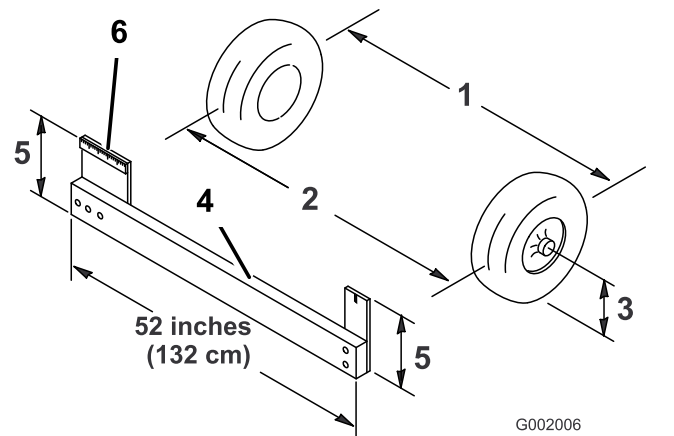

**Figure 33**

1. Tire center line-back
2. Tire center line-front
3. Axle center line
4. Fixture
5. Axle center line distance
6. 15 cm (6 inches) ruler

5. If the measurement does not fall within the specified range, loosen the jam nuts at both ends of the tie rods ([Figure 34](#)).

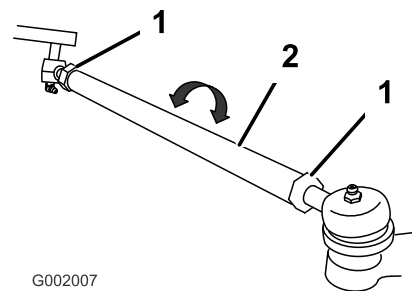

**Figure 34**

1. Jam nut
2. Tie rod

6. Rotate both tie rods to move the front of the tire inward or outward.  
**Note:** The tie rods should be the same length when you are finished.
7. Tighten the tie rod jam nuts when the adjustment is correct.
8. Ensure that there is full travel of the steering wheel in both directions.

# Brake Maintenance

## Checking the Brake Fluid

The brake fluid reservoir is shipped from the factory filled with DOT 3 brake fluid. Check the level before starting the engine each day.

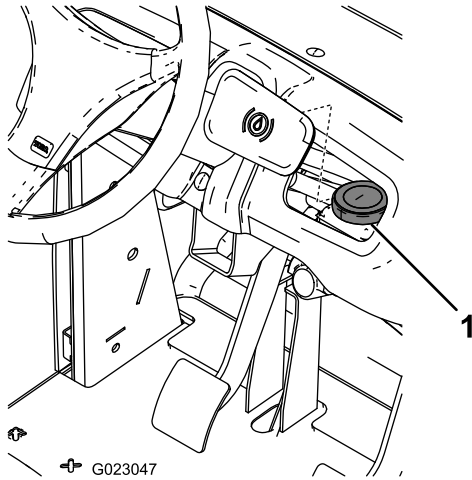

**Figure 35**

1. Brake fluid reservoir

1. Position the sprayer on a level surface, set the parking brake, stop the pump, stop the engine, and remove the ignition key.
2. The fluid level should be up to the Full line on the reservoir.
3. If the fluid level is low, clean the area around the reservoir cap, remove the cap, and fill the reservoir to the proper level. Do not overfill.

## Inspecting the Brakes

**Service Interval:** Every 100 hours

The brakes are a critical safety component of the sprayer. Inspect them as follows:

- Inspect the brake shoes for wear or damage. If the lining (brake pad) thickness is less than 1.6 mm (1/16 inch), replace the brake shoes.
- Inspect the backing plate and other components for signs of excessive wear or deformation. If any deformation is found, replace the appropriate components.

## Adjusting the Parking Brake

**Service Interval:** Every 200 hours—Check the parking brake.

1. Remove the plastic grip.
2. Loosen the set screw securing the knob to the parking brake lever (**Figure 36**).

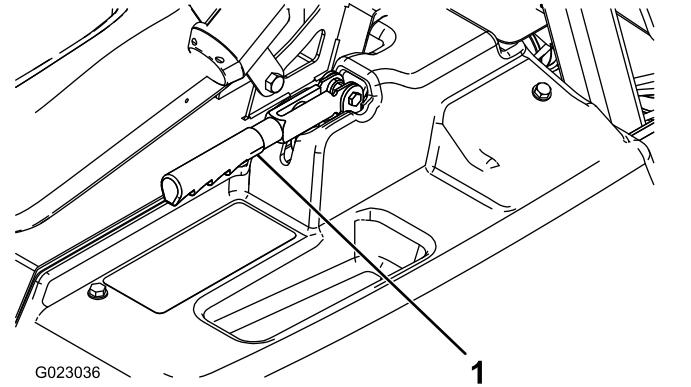

**Figure 36**

1. Parking brake lever

3. Rotate the knob until a force of 18-23 kg (40-50 lb) is required to actuate lever.
4. Tighten the set screw.



# Hydraulic System Maintenance

## Checking the Transaxle/Hydraulic Fluid

**Service Interval:** Every 200 hours

1. Position the sprayer on a level surface, set the parking brake, stop the pump, stop the engine, and remove the ignition key.
2. Remove the transaxle dipstick and wipe it with a clean rag ([Figure 37](#)).

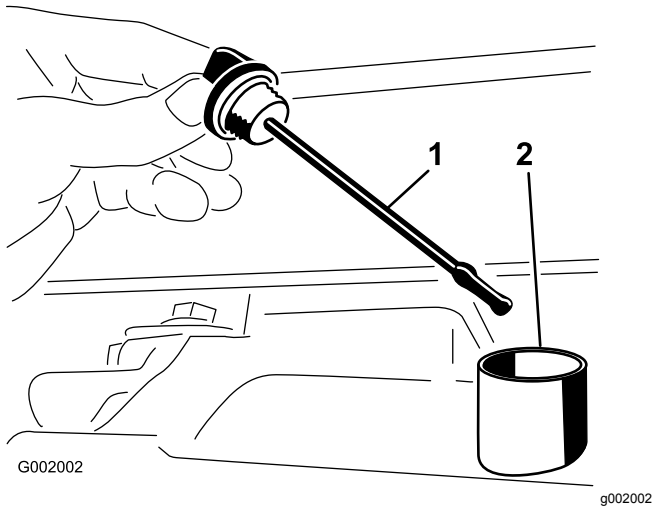

**Figure 37**

1. Dipstick
2. Fill hole

**Important:** Be very careful not to get dirt or other contaminants into the opening when checking the transmission oil.

3. Insert the dipstick into the tube and make sure that it is seated fully. Remove the dipstick and check the oil level.
4. The transaxle fluid level should be at the top of the flat portion of the dipstick. If it is not, fill the reservoir with the appropriate fluid; refer to [Changing Transaxle/Hydraulic Fluid \(page 49\)](#).
5. Install the dipstick firmly in place.

## Changing Transaxle/Hydraulic Fluid

**Service Interval:** Every 800 hours/Yearly (whichever comes first)

1. Position the sprayer on a level surface, set the parking brake, stop the pump, stop the engine, and remove the ignition key.

2. Place a drain pan under the drain plug of the reservoir.
3. Remove the drain plug from the side of the reservoir, and let the hydraulic fluid flow into the drain pan ([Figure 38](#)).

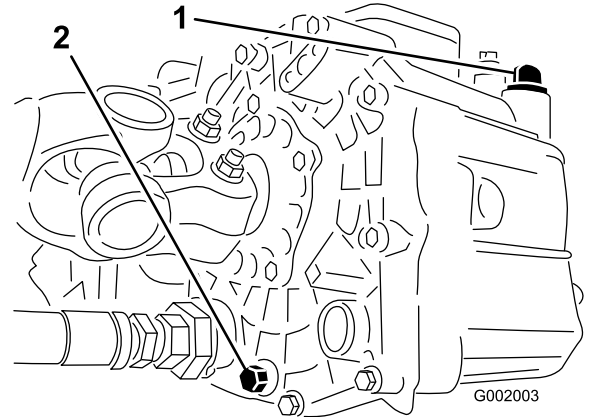

**Figure 38**

1. Hydraulic dipstick
2. Drain plug

4. Note the orientation of the hydraulic hose and 90° fitting connected to the strainer.
5. Remove the hydraulic hose and 90° fitting ([Figure 39](#)).

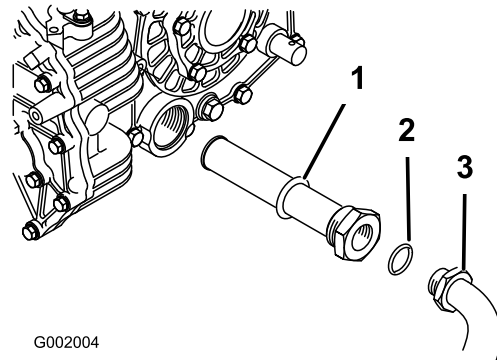

**Figure 39**

1. Hydraulic strainer
2. O-ring
3. 90° fitting

6. Remove the strainer and clean it by back flushing it with a clean degreaser.
7. Allow the strainer to air dry.
8. Install the strainer when the oil is draining.
9. Install the hydraulic hose and 90° fitting to the strainer.
10. Install and tighten the drain plug.
11. Fill the reservoir with approximately 7 L (7.5 qt) of Dexron III ATF.

**Important:** Use only the hydraulic fluids specified. Other fluids could cause system damage.

12. Start the engine and drive the sprayer to fill the hydraulic system.
13. Check the oil level and replenish it, if required.

## Replacing the Hydraulic Filter

**Service Interval:** After the first 8 hours

Every 800 hours/Yearly (whichever comes first)

Use the Toro replacement filter (Part No. 54-0110).

**Important:** Use of any other filter may void the warranty on some components.

1. Position the sprayer on a level surface, set the parking brake, stop the pump, stop the engine, and remove the ignition key.
2. Clean the area around the filter mounting area.
3. Place a drain pan under the filter.
4. Remove the filter (Figure 40).

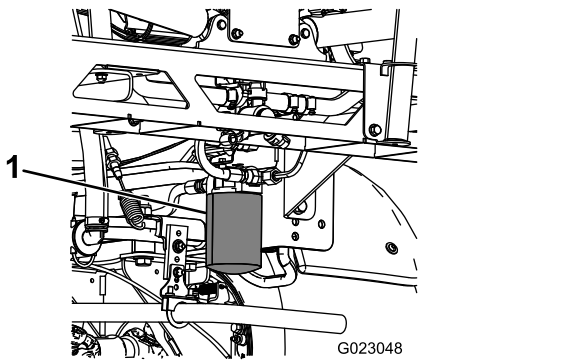

Figure 40

1. Hydraulic filter

5. Lubricate the new filter gasket.
6. Ensure that the filter mounting area is clean.
7. Screw the filter on until the gasket contacts the mounting plate, then tighten the filter one-half turn.
8. Start the engine and let it run for about 2 minutes to purge air from the system.
9. Stop the engine and check the hydraulic oil level and for leaks.

## Spray System Maintenance

### ⚠ WARNING

**Chemical substances used in the spray system may be hazardous and toxic to you, bystanders, animals, plants, soils or other property.**

- Carefully read and follow the chemical warning labels and Material Safety Data Sheets (MSDS) for all chemicals used and protect yourself according to the chemical manufacturer's recommendations. For example, use appropriate Personal Protective Equipment (PPE), including face and eye protection, gloves, or other equipment to guard against personal contact with chemicals.
- Keep in mind that there may be more than one chemical used and information on each should be assessed.
- **Refuse to operate or work on the sprayer if this information is not available!**
- Before working on a spray system make sure that the system has been triple rinsed and neutralized according to the recommendations of the chemical manufacturer(s) and all of the valves have been cycled three times.
- Verify that there is an adequate supply of clean water and soap nearby, and immediately wash off any chemicals that contact you.

## Inspecting the Hoses

**Service Interval:** Every 200 hours—Inspect all hoses and connections for damage and proper attachment.

Examine each hose in the spray system for cracks, leaks or other damage. At the same time, inspect the connections and fittings for similar damage. Replace any hoses and fittings if damaged.

# Inspecting the Pump

**Service Interval:** Every 400 hours/Yearly (whichever comes first)—Inspect the pump diaphragms and replace if necessary (see an Authorized Toro Service Distributor).

Every 400 hours/Yearly (whichever comes first)—Inspect the pump check valves and replace if necessary (see an Authorized Toro Service Distributor).

**Note:** The following machine components are considered parts subject to consumption through use unless found defective and are not covered by the warranty associated with this machine.

Have an Authorized Toro Service Distributor check following internal pump components for damage:

- Pump diaphragms
- Pump check valves assemblies

Replace any components, if necessary.

# Inspecting the Nylon Pivot Bushings

**Service Interval:** Every 400 hours/Yearly (whichever comes first)

1. Position the sprayer on a level surface, set the parking brake, stop the pump, stop the engine, and remove the ignition key.
2. Extend the booms to the spray position and support the booms using stands or straps from a lift.
3. With the weight of the boom supported, remove the bolt and nut securing the pivot pin to the boom assembly (Figure 41).

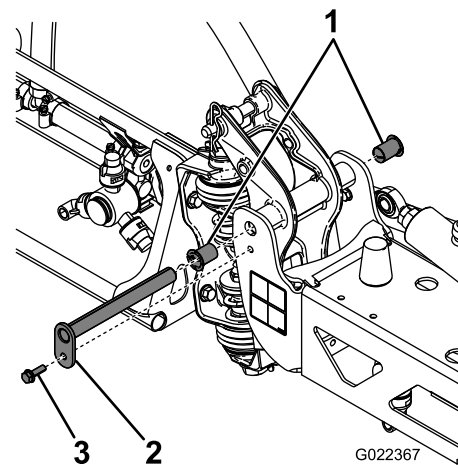

**Figure 41**

1. Nylon bushing
2. Pivot pin
3. Bolt

4. Remove the pivot pin.
5. Remove the boom and pivot bracket assembly from the center frame to access the nylon bushings.
6. Remove and inspect the nylon bushings from the front and back sides of the pivot bracket (Figure 41).
- Note:** Replace any damaged bushings.
7. Place a small amount of oil on the nylon bushings and install them into pivot bracket.
8. Install the boom and pivot bracket assembly into the center frame, aligning the openings (Figure 41).
9. Install the pivot pin and secure it with the bolt and nut removed previously.
10. Repeat the procedure for each boom.

# Cleaning

## Cleaning the Flowmeter

**Service Interval:** Every 200 hours/Yearly (whichever comes first) (more often when using wettable powders).

1. Thoroughly rinse and drain the entire spraying system.
2. Remove the flowmeter from the sprayer, and flush it with clean water.
3. Remove the retainer ring on the upstream side (Figure 42).

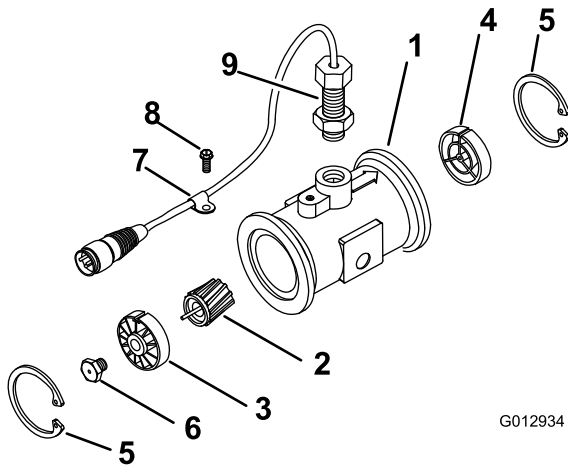

**Figure 42**

- |                                  |                          |
|----------------------------------|--------------------------|
| 1. Modified flanged body         | 6. Turbine stud assembly |
| 2. Rotor/ magnet assembly        | 7. Cable clamp           |
| 3. Hub/ bearing assembly         | 8. Thread screw          |
| 4. Hub assembly (with keyway up) | 9. Sensor assembly       |
| 5. Retaining ring                |                          |

4. Clean the turbine and the turbine hub to remove metal filings and any wettable powders.
5. Inspect the turbine blades for wear.

**Note:** Hold the turbine in your hand and spin it. It should spin freely with very little drag. If it does not, replace it.

6. Assemble the flowmeter.
7. Use a low-pressure air jet (50 kPa or 5 psi) to ensure that the turbine spins freely. If it does not, loosen the hex stud on the bottom of the turbine hub by 1/16 of a turn until the turbine spins freely.

## Cleaning the Suction Strainer

**Service Interval:** Before each use or daily (more often when using wettable powders).

1. Remove the retainer from the red fitting attached to the large hose on the top of the tank.

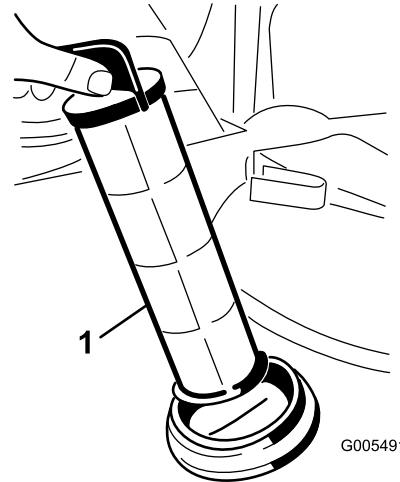

**Figure 43**

1. Suction strainer

2. Disconnect the hose from the tank.
3. Pull the strainer out of the hole.
4. Clean the strainer with clean running water.
5. Replace the strainer, seating it fully into the hole.
6. Connect the hose to the top of the tank and secure it with the retainer.

# Storage

1. Position the sprayer on a level surface, set the parking brake, stop the pump, stop the engine, and remove the ignition key.
2. Clean dirt and grime from the entire machine, including the outside of the engine cylinder head fins and blower housing.

**Important:** You can wash the machine with mild detergent and water. Do not use high-pressure water to wash the machine. Pressure washing may damage the electrical system or wash away necessary grease at friction points. Avoid excessive use of water, especially near the control panel, lights, engine, and the battery.

3. Clean the spray system; refer to the [Cleaning the Sprayer \(page 28\)](#).
4. Clean the pistons in the valve assembly as follows:
  - A. Position the valves in the Off position (shaft close to the hose barb).

**Note:** Make sure that there is no water in the tubing.
  - B. Remove the 3 forks securing the valve seats to the valve assembly.
  - C. Using a 3 mm Allen wrench, remove the screws securing the piston assemblies in the valve assembly. Make sure to account for the springs in the valve.
  - D. Clean the pistons and replace any worn O-rings.
  - E. Coat all piston O-rings with vegetable oil and reinstall in the valve assembly with the screws previously removed. Make sure to install the springs into the valve assembly.
  - F. Secure the valve seats to the valve assembly with the 3 forks previously removed.
  - G. Mount the hose loom bracket to the sprayer frame with the 2 screws and nuts previously removed.
5. Add a rust inhibiting, non-alcohol based, RV antifreeze solution to the system.
  - A. Empty the sprayer and let the pump run until the nozzles are spraying air.
  - B. Pour 50 L (13 US gallons) of a mix of 1/3 RV anti-freeze and 2/3 water into the sprayer tank.
  - C. Run the machine to distribute the anti-freeze mix throughout the system.

6. Use the boom lift switches to raise the booms. Raise the booms until they have moved completely into boom transport cradle forming the "X" transport position and the boom cylinders are fully retracted. Make sure the boom cylinders are fully retracted to prevent actuator rod damage.
7. Inspect the brakes; refer to [Inspecting the Brakes \(page 48\)](#).
8. Service the air cleaner; refer to [Servicing the Air Cleaner \(page 40\)](#).
9. Grease the sprayer; refer to the [Lubrication \(page 39\)](#).
10. Change the crankcase oil; refer to [Servicing the Engine Oil \(page 41\)](#).
11. Check the tire pressure; refer to [Checking the Tire Pressure \(page 23\)](#).
12. For storage over 30 days, prepare the fuel system as follows:
  - A. Add a petroleum based stabilizer/conditioner to fuel in the tank.

Follow mixing instructions from stabilizer manufacturer. Do not use an alcohol based stabilizer (ethanol or methanol).

**Note:** A fuel stabilizer/conditioner is most effective when mixed with fresh gasoline and used at all times.
  - B. Run the engine to distribute conditioned fuel through the fuel system (5 minutes).
  - C. Stop the engine, allow it to cool, and drain the fuel tank.
  - D. Restart the engine and run it until it stops.
  - E. Choke the engine.
  - F. Start and run the engine until it will not start again.
  - G. Dispose of fuel properly. Recycle as per local codes.

**Important:** Do not store stabilizer/conditioned gasoline over 90 days
13. Remove the spark plugs and check their condition; refer to [Changing the Spark Plugs \(page 43\)](#).
14. With the spark plugs removed from the engine, pour two tablespoons of engine oil into the spark plug hole.
15. Use the electric starter to crank the engine and distribute the oil inside the cylinder.

16. Install the spark plugs and tighten to recommended torque; refer to [Changing the Spark Plugs \(page 43\)](#).

**Note:** Do not install the wire on the spark plug(s).

17. Remove the battery from the chassis, check the electrolyte level, and charge it fully; refer to [Servicing the Battery \(page 45\)](#).

**Note:** Do not connect the battery cables to the battery posts during storage.

**Important:** The battery must be fully charged to prevent it from freezing and being damaged at temperatures below 0° C (32° F). A fully charged battery maintains its charge for about 50 days at temperatures lower than 4° C (40° F). If the temperatures will be above 4° C (40° F), check the water level in the battery and charge it every 30 days.

18. Check and tighten all bolts, nuts, and screws. Repair or replace any part that is damaged.
19. Check the condition of all spray hoses, replacing any that are damaged or worn.
20. Tighten all hose fittings.
21. Paint all scratched or bare metal surfaces. Paint is available from your Authorized Service Dealer.
22. Store the machine in a clean, dry garage or storage area.
23. Remove the ignition key and put it in a safe place out of the reach of children.
24. Cover the machine to protect it and keep it clean.

# Troubleshooting

## Troubleshooting the Engine and Vehicle

Problem	Possible Cause	Corrective Action
The starter does not crank.	<ol style="list-style-type: none"> <li>1. The range selector is in a gear other than Neutral.</li> <li>2. The electrical connections are corroded or loose.</li> <li>3. A fuse is blown or loose.</li> <li>4. The battery is discharged.</li> <li>5. The safety interlock system is malfunctioning.</li> <li>6. A starter or starter solenoid is broken.</li> <li>7. The internal engine components have seized.</li> </ol>	<ol style="list-style-type: none"> <li>1. Press the brake pedal and move the range selector to the Neutral position.</li> <li>2. Check the electrical connections for good contact.</li> <li>3. Correct or replace fuse.</li> <li>4. Charge or replace the battery.</li> <li>5. Contact your Authorized Service Dealer.</li> <li>6. Contact your Authorized Service Dealer.</li> <li>7. Contact your Authorized Service Dealer.</li> </ol>
The engine cranks, but will not start.	<ol style="list-style-type: none"> <li>1. The fuel tank is empty.</li> <li>2. Dirt, water, or stale fuel is in the fuel system.</li> <li>3. The fuel line is clogged.</li> <li>4. The spark plug lead is disconnected.</li> <li>5. A spark plug is damaged or dirty.</li> <li>6. The kill relay is not energized.</li> <li>7. The ignition is broken.</li> </ol>	<ol style="list-style-type: none"> <li>1. Fill the tank with fresh fuel.</li> <li>2. Drain and flush the fuel system; add fresh fuel.</li> <li>3. Clean or replace the fuel system.</li> <li>4. Reconnect the spark plug.</li> <li>5. Replace the spark plug.</li> <li>6. Contact your Authorized Service Dealer.</li> <li>7. Contact your Authorized Service Dealer.</li> </ol>
The engine starts, but does not keep running.	<ol style="list-style-type: none"> <li>1. The fuel tank vent is restricted.</li> <li>2. Dirt or water is in the fuel system.</li> <li>3. The fuel filter is clogged.</li> <li>4. A fuse is blown or loose.</li> <li>5. The fuel pump is broken.</li> <li>6. The carburetor is broken.</li> <li>7. There are loose wires or poor connections.</li> <li>8. The cylinder head gasket is broken.</li> </ol>	<ol style="list-style-type: none"> <li>1. Replace the fuel cap.</li> <li>2. Drain and flush the fuel system; add fresh fuel.</li> <li>3. Replace the fuel filter.</li> <li>4. Correct or replace the fuse.</li> <li>5. Contact your Authorized Service Dealer.</li> <li>6. Contact your Authorized Service Dealer.</li> <li>7. Check and tighten wire connections.</li> <li>8. Contact your Authorized Service Dealer.</li> </ol>
The engine runs, but knocks or misses.	<ol style="list-style-type: none"> <li>1. Dirt, water, or stale fuel is in the fuel system.</li> <li>2. A spark plug lead is loose.</li> <li>3. A spark plug is broken.</li> <li>4. There are loose wires or poor connections.</li> <li>5. The engine is overheating.</li> </ol>	<ol style="list-style-type: none"> <li>1. Drain and flush the fuel system; add fresh fuel.</li> <li>2. Reconnect the spark plug lead.</li> <li>3. Replace the spark plug.</li> <li>4. Check and tighten wire connections.</li> <li>5. See "The engine overheats" below.</li> </ol>



Problem	Possible Cause	Corrective Action
The engine will not idle.	<ol style="list-style-type: none"> <li>1. The fuel tank vent is restricted.</li> <li>2. Dirt, water, or stale fuel is in the fuel system.</li> <li>3. A spark plug is damaged or broken.</li> <li>4. Carburetor idle passages are plugged.</li> <li>5. The idle speed adjusting screw is incorrectly set.</li> <li>6. The fuel pump is broken.</li> <li>7. There is low compression.</li> <li>8. The air cleaner element is dirty.</li> </ol>	<ol style="list-style-type: none"> <li>1. Replace the fuel cap.</li> <li>2. Drain and flush the fuel system; add fresh fuel.</li> <li>3. Replace the spark plug.</li> <li>4. Contact your Authorized Service Dealer.</li> <li>5. Contact your Authorized Service Dealer.</li> <li>6. Contact your Authorized Service Dealer.</li> <li>7. Contact your Authorized Service Dealer.</li> <li>8. Clean or replace the element.</li> </ol>
The engine overheats.	<ol style="list-style-type: none"> <li>1. The crankcase oil level is incorrect.</li> <li>2. There is excessive loading.</li> <li>3. The air intake screens are dirty.</li> <li>4. The cooling fins and air passages under the engine blower housing and/or the rotating air intake screen are plugged.</li> <li>5. The fuel mixture is lean.</li> </ol>	<ol style="list-style-type: none"> <li>1. Fill or drain to the full mark.</li> <li>2. Reduce the load; use lower ground speed.</li> <li>3. Clean with every use.</li> <li>4. Clean with every use.</li> <li>5. Contact your Authorized Service Dealer.</li> </ol>
The engine loses power.	<ol style="list-style-type: none"> <li>1. The crankcase oil level is incorrect.</li> <li>2. The air cleaner element is dirty.</li> <li>3. Dirt, water, or stale fuel is in the fuel system.</li> <li>4. The engine is overheated.</li> <li>5. A spark plug is damaged or dirty.</li> <li>6. The vent hole in the fuel tank vent fitting is plugged.</li> <li>7. There is low compression.</li> </ol>	<ol style="list-style-type: none"> <li>1. Fill or drain to the full mark.</li> <li>2. Clean or replace.</li> <li>3. Drain and flush the fuel system; add fresh fuel.</li> <li>4. See Engine Overheats.</li> <li>5. Replace the spark plug.</li> <li>6. Replace the fuel cap.</li> <li>7. Contact your Authorized Service Dealer.</li> </ol>
There is abnormal vibration or noise.	<ol style="list-style-type: none"> <li>1. The engine mounting bolts are loose.</li> <li>2. There is a problem with the engine.</li> </ol>	<ol style="list-style-type: none"> <li>1. Tighten the engine mounting bolts.</li> <li>2. Contact your Authorized Service Dealer.</li> </ol>
The machine will not operate or is sluggish in either direction because the engine bogs down or stalls.	<ol style="list-style-type: none"> <li>1. The parking brake is set.</li> </ol>	<ol style="list-style-type: none"> <li>1. Release the parking brake.</li> </ol>
The machine will not operate in either direction.	<ol style="list-style-type: none"> <li>1. The range selector is in the Neutral position.</li> <li>2. The parking brake was not released or the parking brake is not releasing.</li> <li>3. The transmission is broken.</li> <li>4. The control linkage needs adjustment or replacement.</li> <li>5. The drive shaft or wheel hub key has been damaged.</li> </ol>	<ol style="list-style-type: none"> <li>1. Press the brake and shift the range selector into a gear.</li> <li>2. Release the parking brake or check the linkage.</li> <li>3. Contact your Authorized Service Dealer.</li> <li>4. Contact your Authorized Service Dealer.</li> <li>5. Contact your Authorized Service Dealer.</li> </ol>



# Troubleshooting the Spray System

Problem	Possible Cause	Corrective Action
A boom section does not spray.	<ol style="list-style-type: none"> <li>1. The electrical connection on the boom valve is dirty or disconnected.</li> <li>2. There is a blown fuse.</li> <li>3. There is a pinched hose.</li> <li>4. A boom by-pass valve is improperly adjusted.</li> <li>5. There are damaged boom valve.</li> <li>6. The electrical system is damaged.</li> </ol>	<ol style="list-style-type: none"> <li>1. Turn the valve off manually. Disconnect the electrical connector on the valve and clean all leads, then reconnect it.</li> <li>2. Check the fuses and replace them as necessary.</li> <li>3. Repair or replace the hose.</li> <li>4. Adjust the boom by-pass valves.</li> <li>5. Contact your Authorized Service Dealer.</li> <li>6. Contact your Authorized Service Dealer.</li> </ol>
A boom section does not turn off.	<ol style="list-style-type: none"> <li>1. The valve is damaged.</li> </ol>	<ol style="list-style-type: none"> <li>1. Stop the spray system and pump and turn off the sprayer. Remove the retainer from under the boom valve and pull out the motor and stem. Inspect all parts and replace any that appear damaged.</li> </ol>
A boom valve is leaking.	<ol style="list-style-type: none"> <li>1. An O-ring is deteriorated.</li> </ol>	<ol style="list-style-type: none"> <li>1. Stop the spray system and pump and turn off the sprayer. Disassemble the valve and replace the O-rings.</li> </ol>
A pressure drop occurs when you turn on a boom.	<ol style="list-style-type: none"> <li>1. The boom bypass is improperly adjusted.</li> <li>2. There is an obstruction in the boom valve body.</li> <li>3. A nozzle filter is damaged or clogged.</li> </ol>	<ol style="list-style-type: none"> <li>1. Adjust the boom bypass.</li> <li>2. Remove the inlet and outlet connections to the boom valve and remove any obstructions.</li> <li>3. Remove and inspect all nozzles.</li> </ol>
The boom actuator is not operating properly.	<ol style="list-style-type: none"> <li>1. A thermal breaker in the fuse block responsible for powering the actuator has tripped due to overheating.</li> <li>2. A thermal breaker in the boom actuator responsible for powering the actuator has tripped or malfunctioned.</li> </ol>	<ol style="list-style-type: none"> <li>1. Wait for the system to cool down before resuming operation. If the thermal breakers trip repeatedly, contact your Authorized Service Dealer.</li> <li>2. Contact your Authorized Service Dealer.</li> </ol>

# Schematics

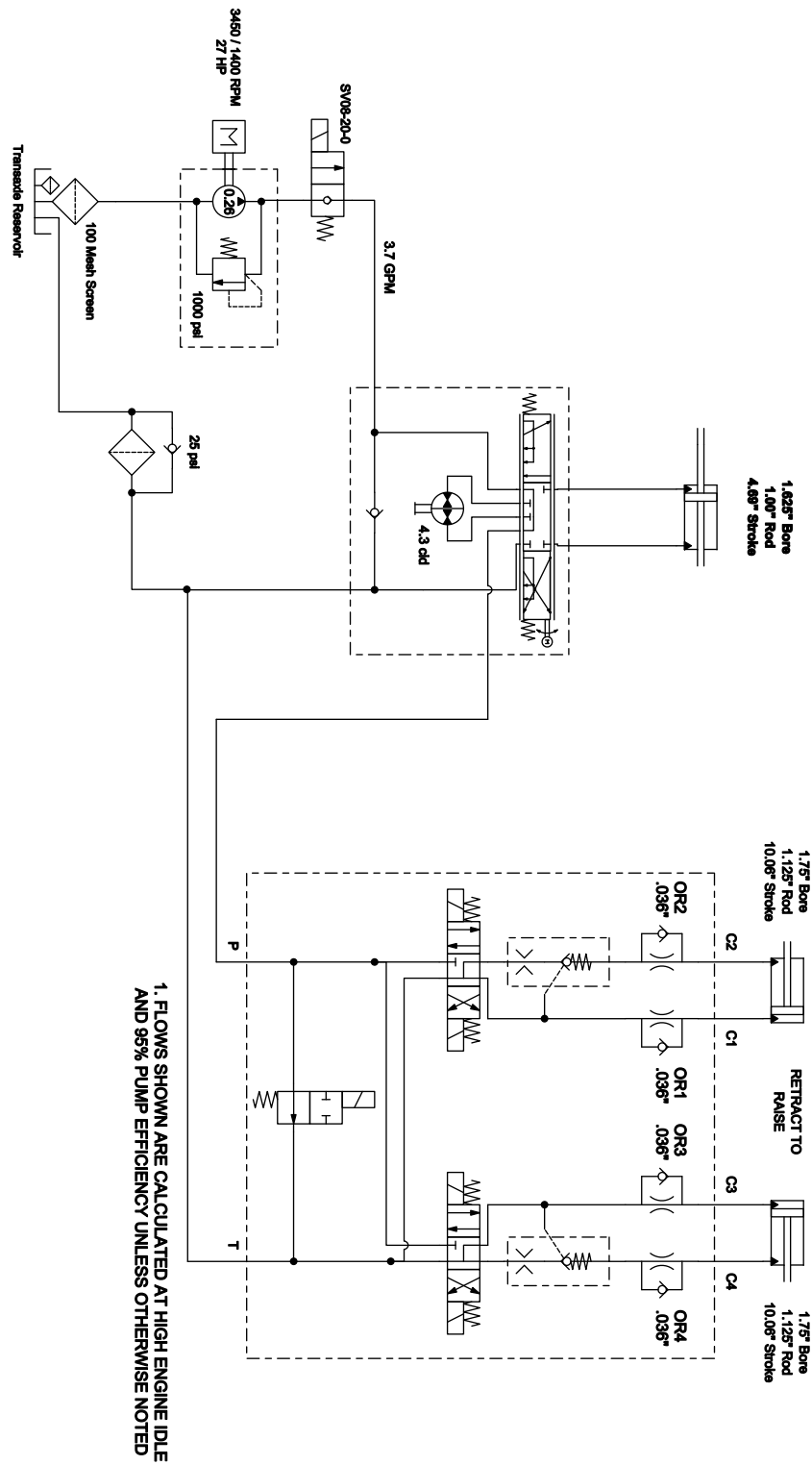

G023049

g023049

Hydraulic Schematic (Rev. A)





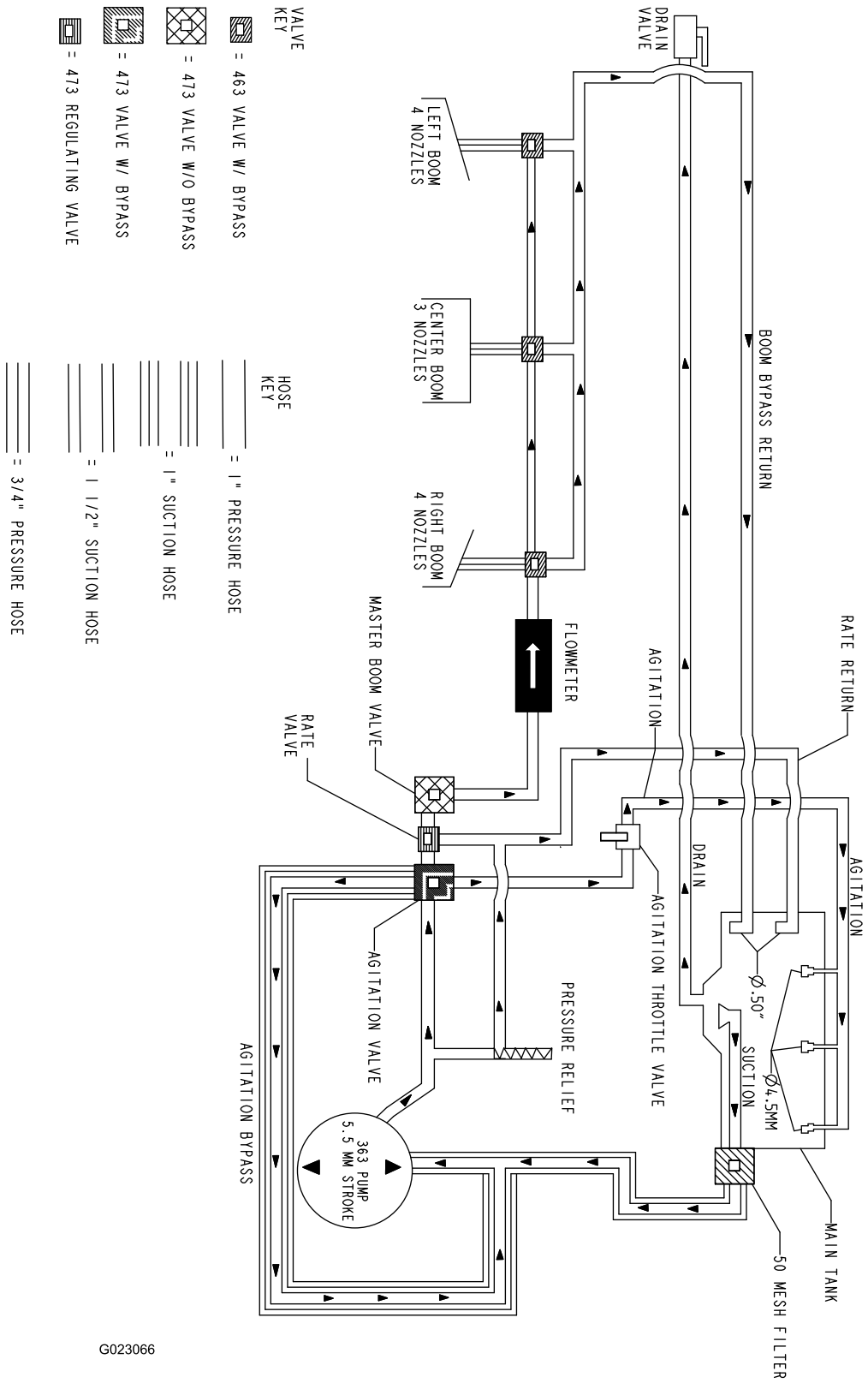

G023066

g023066

Flow Diagram (Rev. A)

**Notes:**

**Notes:**



# The Toro Total Coverage Guarantee

## A Limited Warranty

### Conditions and Products Covered

The Toro Company and its affiliate, Toro Warranty Company, pursuant to an agreement between them, jointly warrant your Toro Commercial product ("Product") to be free from defects in materials or workmanship for two years or 1500 operational hours\*, whichever occurs first. This warranty is applicable to all products with the exception of Aerators (refer to separate warranty statements for these products). Where a warrantable condition exists, we will repair the Product at no cost to you including diagnostics, labor, parts, and transportation. This warranty begins on the date the Product is delivered to the original retail purchaser.

\* Product equipped with an hour meter.

### Instructions for Obtaining Warranty Service

You are responsible for notifying the Commercial Products Distributor or Authorized Commercial Products Dealer from whom you purchased the Product as soon as you believe a warrantable condition exists. If you need help locating a Commercial Products Distributor or Authorized Dealer, or if you have questions regarding your warranty rights or responsibilities, you may contact us at:

Toro Commercial Products Service Department  
Toro Warranty Company  
8111 Lyndale Avenue South  
Bloomington, MN 55420-1196  
952-888-8801 or 800-952-2740  
E-mail: commercial.warranty@toro.com

### Owner Responsibilities

As the Product owner, you are responsible for required maintenance and adjustments stated in your *Operator's Manual*. Failure to perform required maintenance and adjustments can be grounds for disallowing a warranty claim.

### Items and Conditions Not Covered

Not all product failures or malfunctions that occur during the warranty period are defects in materials or workmanship. This warranty does not cover the following:

- Product failures which result from the use of non-Toro replacement parts, or from installation and use of add-on, or modified non-Toro branded accessories and products. A separate warranty may be provided by the manufacturer of these items.
- Product failures which result from failure to perform recommended maintenance and/or adjustments. Failure to properly maintain your Toro product per the Recommended Maintenance listed in the *Operator's Manual* can result in claims for warranty being denied.
- Product failures which result from operating the Product in an abusive, negligent, or reckless manner.
- Parts subject to consumption through use unless found to be defective. Examples of parts which are consumed, or used up, during normal Product operation include, but are not limited to, brake pads and linings, clutch linings, blades, reels, rollers and bearings (sealed or greasable), bed knives, spark plugs, castor wheels and bearings, tires, filters, belts, and certain sprayer components such as diaphragms, nozzles, and check valves, etc.
- Failures caused by outside influence. Conditions considered to be outside influence include, but are not limited to, weather, storage practices, contamination, use of unapproved fuels, coolants, lubricants, additives, fertilizers, water, or chemicals, etc.
- Failure or performance issues due to the use of fuels (e.g. gasoline, diesel, or biodiesel) that do not conform to their respective industry standards.

### Countries Other than the United States or Canada

Customers who have purchased Toro products exported from the United States or Canada should contact their Toro Distributor (Dealer) to obtain guarantee policies for your country, province, or state. If for any reason you are dissatisfied with your Distributor's service or have difficulty obtaining guarantee information, contact the Toro importer.

- Normal noise, vibration, wear and tear, and deterioration.
- Normal "wear and tear" includes, but is not limited to, damage to seats due to wear or abrasion, worn painted surfaces, scratched decals or windows, etc.

### Parts

Parts scheduled for replacement as required maintenance are warranted for the period of time up to the scheduled replacement time for that part. Parts replaced under this warranty are covered for the duration of the original product warranty and become the property of Toro. Toro will make the final decision whether to repair any existing part or assembly or replace it. Toro may use remanufactured parts for warranty repairs.

### Deep Cycle and Lithium-Ion Battery Warranty:

Deep cycle and Lithium-Ion batteries have a specified total number of kilowatt-hours they can deliver during their lifetime. Operating, recharging, and maintenance techniques can extend or reduce total battery life. As the batteries in this product are consumed, the amount of useful work between charging intervals will slowly decrease until the battery is completely worn out. Replacement of worn out batteries, due to normal consumption, is the responsibility of the product owner. Battery replacement may be required during the normal product warranty period at owner's expense. Note: (Lithium-Ion battery only): A Lithium-Ion battery has a part only prorated warranty beginning year 3 through year 5 based on the time in service and kilowatt hours used. Refer to the *Operator's Manual* for additional information.

### Maintenance is at Owner's Expense

Engine tune-up, lubrication, cleaning and polishing, replacement of filters, coolant, and completing recommended maintenance are some of the normal services Toro products require that are at the owner's expense.

### General Conditions

Repair by an Authorized Toro Distributor or Dealer is your sole remedy under this warranty.

**Neither The Toro Company nor Toro Warranty Company is liable for indirect, incidental or consequential damages in connection with the use of the Toro Products covered by this warranty, including any cost or expense of providing substitute equipment or service during reasonable periods of malfunction or non-use pending completion of repairs under this warranty. Except for the Emissions warranty referenced below, if applicable, there is no other express warranty. All implied warranties of merchantability and fitness for use are limited to the duration of this express warranty.**

Some states do not allow exclusions of incidental or consequential damages, or limitations on how long an implied warranty lasts, so the above exclusions and limitations may not apply to you. This warranty gives you specific legal rights, and you may also have other rights which vary from state to state.

### Note regarding engine warranty:

The Emissions Control System on your Product may be covered by a separate warranty meeting requirements established by the U.S. Environmental Protection Agency (EPA) and/or the California Air Resources Board (CARB). The hour limitations set forth above do not apply to the Emissions Control System Warranty. Refer to the Engine Emission Control Warranty Statement supplied with your product or contained in the engine manufacturer's documentation for details